

# SAKAI®

# SW994

## SERIES

Asphalt Roller



## Oscillatory/Vibratory Tandem Rollers

### Efficient compaction with various vibratory modes

#### Best Compaction Quality and Efficiency

- Sakai's new ECO Compaction Mode (ECM) reduces fuel consumption up to 10%.
- SW994 standard model features 4,000vpm high frequency vibration, which achieves the desired density faster and more efficiently while creating a smoother finish.
- EXACT COMPACT METER matches speed for obtaining the correct number of IPF (impacts per foot)
- Frequency and amplitude modes can be switched from the seat
- Cross-mounted drive and vibration motors eliminate machine torque on the mat
- Counter rotation of eccentric weights in the drums cancel horizontal force
- Timer, auto or constant operated water spray system

## SW994

#### Dual Drum Oscillation "Osc" & Vibration "Vibe" (SW994ND)

- Versatility by switching on the fly from Vibe for high compaction efforts to Osc for smooth finish of the pavement surface
- Optimized dual drum Osc achieves target density of thin lift pavement (1-1.5") in fewer passes and increases paving train speed
- Osc achieves density on no-vibe jobs where structural integrity is a concern

#### Operator Comfort

- Multi-position operator station (MPOS) (5 positions)
- 180° easy rotating operator console
- Lunch box table and cup holder
- Excellent drum edge visibility from the operator seat
- Digital programmable cruise control

#### High Safety Standards

- Sakai proprietary emergency brake pedal, which kills the engine and stops the machine instantly
- 3 inch retractable seat belt
- 39 inches of visibility to the front and rear from the operator's seat
- Low profile design
- SAHR (spring applied-hydraulic released) brake

#### Easy Maintenance

- Sprinkler system with plastic water tanks, triple-filtration, removable brass nozzles for ease of maintenance with pressurized winterization
- Easy ground level access to all check points
- Ground level access to all consumable items, such as filters
- Long life drum isolators
- Gear drive Osc/Vibe system (no belt)



## SW994ND

[www.sakaiamerica.com](http://www.sakaiamerica.com)

Options shown. Contact your dealer for details.

# SW994 SERIES

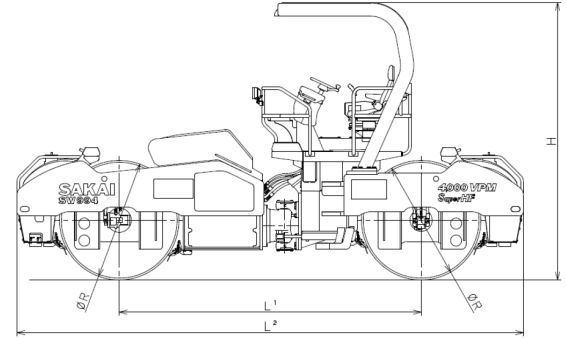
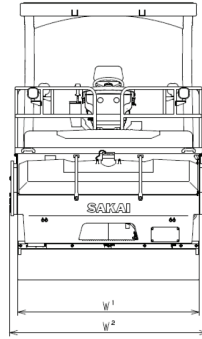

MODEL		SW994	SW994ND	
<b>WEIGHTS</b>	Max. operating weight with ROPS	kg (lbs)	14,000 (30,865)	14,320 (31,570)
	Operating weight with ROPS	kg (lbs)	13,270 (29,255)	13,590 (29,960)
	Load on front axle - operating weight with ROPS	kg (lbs)	6,530 (14,395)	6,690 (14,750)
	Load on rear axle - operating weight with ROPS	kg (lbs)	6,740 (14,860)	6,900 (15,210)
<b>PERFORMANCE</b>	Centrifugal force	kN (lbs) [kgf]	Low : 173 / 98 / 68 (38,890 / 22,030 / 15,285) [17,640 / 9,995 / 6,935] Hi : 185 / 128 (41,590 / 28,775) [18,865 / 13,050]	Vibe : 158 (35,585) [16,110] Osci : 172 (38,600) [17,540]
	Frequency	Hz (vpm)	Low : 66.7 / 50.0 / 41.7 (4,000 / 3,000 / 2,500) Hi : 50.0 / 41.7 (3,000 / 2,500)	Vibe : 50 (3,000) Osci : 46.7 (2,800)
	Amplitude	mm (in)	0.34 / 0.65 (0.013 / 0.026)	Vibe : 0.54 (0.021) Osci : 0.56 (0.022)
	Dynamic linear pressure for front drum - operating weight with ROPS	N/cm (lb/in)	Low : 1,113 / 761 / 620 (635 / 435 / 354) Hi : 1,169 / 902 (668 / 515)	Vibe : 1,051 (600)
	Dynamic linear pressure for rear drum - operating weight with ROPS	N/cm (lb/in)	Low : 1,123 / 770 / 630 (641 / 440 / 359) Hi : 1,179 / 911 (673 / 520)	Vibe : 1,061 (606)
	Number of speed shifts		2	2
	Speed range (L / H)	km/h (mph)	0 - 7.2 @ 4,000vpm, 0 - 5.5 @ 3,000vpm, 0 - 4.5 @ 2,500 vpm / 0 - 11 (0 - 4.5, 0 - 3.4, 0 - 2.8 / 0 - 6.8)	0 - 5.5@Vibe, 0 - 6.4@Osci / 0 - 11 (0-3.4, 0-4.0 / 0 - 6.8)
	Gradeability	% (°)	28 (15)	28 (15)
	Turning radius compacted surface (inside / outside)	m (in)	4.3 / 6.4 (170 / 252)	4.3 / 6.4 (170 / 252)
	<b>DIMENSIONS</b>	Overall length L <sup>2</sup>	mm (in)	5,940 (234)
Overall width W <sup>2</sup>		mm (in)	2,325 (92)	2,325 (92)
Overall height (without ROPS)		mm (in)	2,375 (94)	2,360 (93)
Overall height (with ROPS) H		mm (in)	3,250 (128)	3,235 (127)
Wheelbase L <sup>1</sup>		mm (in)	3,540 (139)	3,540 (139)
Compaction width W <sup>1</sup>		mm (in)	2,130 (84)	2,130 (84)
Drum width W <sup>1</sup> / Drum diameter R		mm (in)	2,130 / 1,400 (84 / 55)	2,130 / 1,370 (84 / 54)
Shell thickness		mm (in)	22 (0.9)	21 (0.8)
Ground clearance		mm (in)	335 (13.1)	320 (12.5)
Curb clearance		mm (in)	750 (29.6)	735 (29.0)
Side clearance		mm (in)	96 (3.8)	96 (3.8)
<b>ENGINE</b>		Make		CUMMINS
		Model		QSF3.8
	EPA emission standard		EPA Tier 4	
	Type		Diesel, water cooled, 4 cycle, 4 cylinder, with turbo charger	
	Displacement	L (cu.in)	3.800 (229.0)	
	Rated output	kW (HP) /min-1	97.0 (130) / 2,200	
	Electric system battery	V (V/CCA×Qty)	12 (12 / 1000×1)	
	Electric system alternator	V/A	12 / 135	
<b>DRIVE SYSTEM</b>	Power transmission type		Hydrostatic	
	Drive wheel		All wheel (2 drums)	
<b>VIBRATION SYSTEM</b>	Power transmission type		Hydraulic	
	Number of amplitude		2	
	Vibrator type		Double eccentric shafts	
<b>BRAKE SYSTEM</b>	Service brake		Dynamic braking through hydrostatic drive system / F-N-R lever	
	Secondary brake(Emergency brake)		Hydrostatic + Spring applied hydraulically released type (SAHR) / Brake pedal	
	Parking brake		SAHR / Panel button	
<b>STEERING SYSTEM</b>	Power transmission type		Hydraulic	
	Articulation / Oscillating angle	± (°)	36.7 / 6.5	
<b>FLUID CAPACITY</b>	Fuel tank	L (gal)	292 (77.1)	
	Hydraulic oil tank	L (gal)	65 (17.2)	
	Water sprinkler tank	L (gal)	2×600 (2×158.5)	
	DEF tank	L (gal)	19 (5.0)	

- Specified figures have a tolerance of ±5%.
- All specifications may be changed without notice.
- Specified figures are in SI Units, followed by their equivalent in English units of measurement in parentheses.
- Max. operating weight : Fuel=100%, Water=100%, Operator=75kg
- Operating weight : Fuel=50%, Water=50%, Operator=75kg
- The photos may contain optional equipment and/or attachment.

#### Optional equipment

- ROPS(Low profile)
- CABIN
- Rear-view mirror
- LED working lights
- LED drum light kit
- Coco mats
- Rotary beacon



**SAKAI AMERICA, INC.**  
**(800) 323-0535**

90 INTERNATIONAL PARKWAY, ADAIRSVILLE, GEORGIA 30103