

⚠ Read this handbook thoroughly and understand the whole information contained before trying to operate, inspect and service your machine!

**OPERATING &
MAINTENANCE
INSTRUCTIONS**

**VIBRATING
ROLLER**

MODEL

GW754

From GW754 → 1GW4 – 40101

SAKAI®

PREFACE

This operator's manual serves as a guide for the use of your SAKAI GW754 Vibrating Roller for those who are new to the machine, and also for the people who have experience in using the machine and want to refresh their knowledge for the machine.

Read this manual thoroughly and try to fully understand the information before operating your machine. Keep this handbook at hand whenever you do your work.

When an instruction manual is lost or is damaged and is not legible, replace it immediately.

The main subjects of this manual are:

(1) Basic precautions for safety, (2) Operation, (3) Daily maintenance and (4) Specifications. For operation and maintenance of the engine, refer to the Engine Instruction Manual furnished separately. Descriptions in this manual can differ from the machine instructions of your machine due to the results of the investigation and improvement in its design. If you have any inquiry regarding your machine or this manual, contact our distributors.

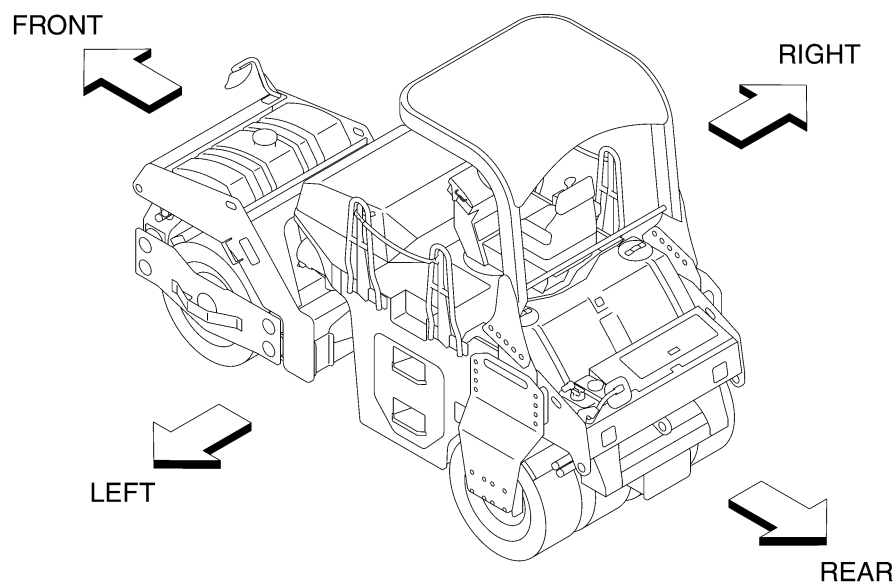

CALIFORNIA

Proposition 65 Warning

Diesel engine exhaust and some of its constituents are known to the State of California to cause cancer, birth defects, and other reproductive harm.

CONTENTS

PREFACE

MACHINE AND ENGINE IDENTIFICATION NUMBERS	1
SAFETY NOTICES	2

1 BASIC PRECAUTIONS FOR SAFETY	4
1.1 General Precautions.....	4
1.2 Preparation for Safe Operation	8
1.3 Before Starting the Engine	9
1.4 After Starting the Engine	10
1.5 During Operation	11
1.6 Loading and Unloading	14
1.7 Transportation	14
1.8 Handling the Battery	15
1.9 Towing.....	16
1.10 Before Servicing	17
1.11 During Servicing	19
1.12 Safety Decals	22
2 OPERATION.....	25
2.1 Instruments and Controls	25
2.1.1 Operator's station	25
2.1.2 Gauges, indicator lamps and warning lamps.....	26
2.1.3 Switches	31
2.1.4 Operating levers and pedals.....	37
2.1.5 Unloader valve.....	39
2.1.6 Fuse box.....	39
2.1.7 Fusible link.....	40
2.1.8 Accessory socket.....	40
2.2 Handling and Adjustments	41
2.2.1 Seat adjustment.....	41
2.2.2 Replacement of scraper.....	42
2.2.3 Disengaging the brake when towing.....	42
2.2.4 Operator's platform position adjustment	43
2.2.5 Engine troubleshooting	43
2.3 Operation.....	44
2.3.1 Before-starting inspection	44
2.3.2 Starting the engine.....	45
2.3.3 After starting the engine.....	47
2.3.4 Traveling	48
2.3.5 Stopping / Parking	50
2.3.6 Stopping the engine.....	51
2.3.7 Check after stopping the engine	52
2.4 Vibratory Operation	52
2.5 Operating the After Treatment System.....	54
2.5.1 DPF.....	54
2.5.2 DEF SCR system.....	57

2.6	Sprinkler / Changeover Valve.....	60
2.7	Liquid Sprayer	64
2.8	Precautions for Work.....	66
2.8.1	Compaction operation.....	66
2.8.2	When going downhill.....	66
2.8.3	On a slope	66
2.9	Applicable Jobs	67
2.10	After Operation	68
2.11	Loading and Unloading	68
2.11.1	Use of a truck or trailer equipped with a winch	69
2.11.2	Self-propelling.....	70
2.12	After Loading the Machine	70
2.13	Transportation	70
2.14	Operation in Cold Weather.....	71
2.14.1	Fuel oil and grease	71
2.14.2	Coolant	71
2.14.3	DEF.....	72
2.14.4	Battery	73
2.15	When the Cold Season is Over	74
2.16	For a Long Storage Period.....	74
2.17	During the Storage Period.....	75
2.18	When the Battery Has Discharged.....	76
2.18.1	Connection and disconnection of booster cables	76
3	PERIODICAL MAINTENANCE.....	78
3.1	Precautions	78
3.1.1	Lifting the machine on a hoist.....	81
3.2	Walk-Around Checking.....	82
3.3	Periodical Maintenance Points	84
3.4	Maintenance Procedure	86
(1)	Every 10 hours or daily.....	86
(2)	Every 50 hours	88
(3)	Every 250 hours	90
(4)	Every 500 hours	91
(5)	Every 500 hours or 3 months, or each time after brake pedal is used	95
(6)	Every 1000 hours	96
(7)	Every 1500 hours	97
(8)	Every 3000 hours	97
(9)	As required	98
3.5	Consumable Parts.....	104
3.5.1	Changing the DEF pump filter	106
3.5.2	Replacement of filter in DEF.....	107
3.6	Fluid and Lubricant Capacities	108
3.7	Electric Wiring Diagram	111
4	SPECIFICATIONS.....	114

MACHINE AND ENGINE IDENTIFICATION NUMBERS

When ordering parts or making inquiries about your machine, the following information is requested.

(1) Machine model

Indicated on the nameplate of the dashboard in the operator's station.

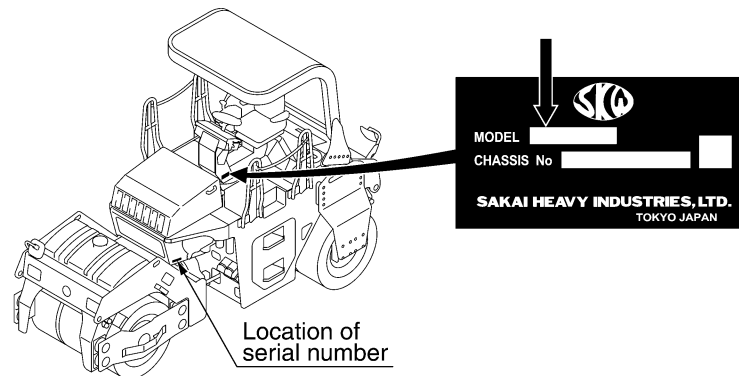

(2) Machine serial number

GW754 → 1GW4 - ○○○○○○

(3) Engine serial number

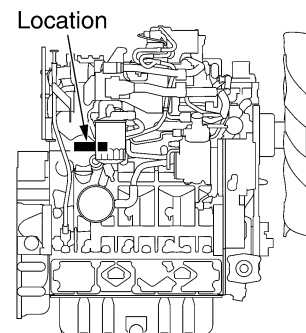

SAFETY NOTICES

For the safe use of your machine, correct handling and periodical maintenance are of utmost importance. Thoroughly read the safety precautions described in this manual. Do not attempt to operate and maintain your machine until you gain a full understanding of these safety statements.

This manual covers the proper and safe method of driving and handling of this machine for its intended use. When this machine is used in a manner other than those covered in this manual, you must assume responsibility for your own personal safety.

In this manual and on the machine, you will find safety notices. Each safety notice starts with a signal word as shown below:

 DANGER

Denotes that there is an extreme hazard. If you fail to take proper precautions, it is highly likely that you could be killed or seriously injured (The color of the symbol  is red).

 WARNING

Denotes that there is a hazard. If you fail to take proper precautions, you could be killed or seriously injured (Symbol  is orange).

 CAUTION

Calls attention to safety practices. If you fail to take proper precautions, you could be injured or cause damage to the machine (Symbol  is yellow).

It is almost impossible for the safety notices in this manual and on the machine to cover all the potential dangers. Keep alert to possible dangers not mentioned in this manual and on the decals.

 **WARNING**

Do not operate your machine before you read its operator's manual thoroughly.

Incorrect operation can kill or cause injury.

It is your responsibility to operate the machine safely.

☆ Making alterations to the machine.

Please do not make alterations to the machine without permission for safety reasons.

We shall not be held responsible for injuries, death or breakdowns caused by alterations.

☆ Basic precautions for safe operation of your machine are described beginning on page 4.

☆ To operate and work with your machine, you must be qualified.

1 BASIC PRECAUTIONS FOR SAFETY

1 BASIC PRECAUTIONS FOR SAFETY

1.1 General Precautions

■ Ensure proper management of health

- People under the influence of alcohol, drugs, lack of sleep or health problems must avoid driving or repairing the machine at all times, as it may lead to serious accidents.

■ Turn off cell phones

- Turn off cell phones while driving or repairing the machine. Never drive while talking on a cell phone, as it may lead to serious accidents.

■ Read the operator's manual thoroughly

- Understand the functions of the controls and gauges. Familiarize yourself with their location and how to operate them. Understand the meaning of all the symbols.



■ When an instruction manual is lost or is damaged and is not legible, replace it immediately

■ Understanding the uses for the machine

- This machine was developed and manufactured mainly for the purpose of rolling compaction in engineering works. Do not use it for any other purpose. Vibration rolling compaction under conditions of excessive compaction, or using it to crush rocks can damage the machine.

■ Obey the worksite rules

- Follow noise standards and worksite rules such as matters forbidden or to be attended to, and working procedures.

⚠ WARNING: Negligence of these instructions can lead to accidents.

1 BASIC PRECAUTIONS FOR SAFETY

■ Wear protective clothing appropriate to work

- Wear clothing, safety shoes and hard hat to suit your work.
- Do not wear clothing and accessories that tend to get caught in the controls or protruded portions of the machine. Do not wear oily clothing.
- Depending on the type of job, wear gloves, earplugs safety goggles or a mask.



■ Know the work area in advance

- Know the terrain, geology and conditions of the road surface at the worksite. Start working after securing safety such as stationing a guardsman or putting up barriers where there is a risk of falling of the machine or collapse of shoulder.

■ The operator must make prior checks when moving the machine to a hazardous area under unusual conditions

■ Provide against an accident

- Decide in advance the means of communication in an emergency. Know the location and use of an extinguisher and first-aid kit.

■ Realize the capability of the machine

- Thoroughly understand the performance of your machine and correctly operate the machine to meet the requirements of the job site. Operating the machine beyond its capabilities may lead to an accident. Use your machine within its capability.

■ The machines not equipped with ROPS must not be operated on the slope or unsafe ground

■ The machines not equipped with CABIN must not be operated in the bad weather or a harmful contaminated zone

1 BASIC PRECAUTIONS FOR SAFETY

■ Do not use a machine which has not been serviced correctly at regular intervals

- Before working, perform necessary inspections. Start operation only after making certain the machine is in good operating condition. If found to be abnormal, report to the responsible person and have the fault corrected. Operate the machine after making sure that it is safe to operate.

■ Do not allow anyone to enter the work area except for authorized personnel

- Always conduct the work paying attention to the workers around the machine.



■ Beware when operating moving parts

- When operating moving parts such as covers, be sure to understand the way they move and take care not to get the hands and feet caught.

■ Operator must sit in the seat when operating the machine

■ Be careful of hot parts

- After your machine has operated for some time, the coolant, engine oil and hydraulic fluid will become hot and the pressure will build up. If, in this state, you try to remove the filler caps, drain the oil or replace the filters, you can get burned. Perform this work in accordance with the correct procedures with the machine cooled down.
- To remove the radiator cap, slowly loosen the cap to relieve the pressure with the engine stopped and the coolant cooled down (For the radiator cap with a lever, lift the lever to release the trapped pressure).
- When removing the filler cap on the hydraulic tank, release the trapped pressure by turning it out slowly to prevent the oil from gushing out (For the cap with a lever, lift the lever to release the trapped pressure).
- While the engine is running or immediately after it has been stopped, do not touch the engine, muffler, exhaust pipes, oil hydraulic pumps, oil hydraulic motors, lights, etc., as they will be hot.
- Resin and metallic parts may become hot under direct sunlight on a hot day. Direct contact with such parts may cause burns, so be sure to wear clothing and protective equipment appropriate for the job.



⚠ WARNING: Negligence of these instructions can lead to accidents.

1 BASIC PRECAUTIONS FOR SAFETY

■ Be careful with fire

- The fuel, oil, and antifreeze will catch fire if open flames or ignition sources are used close to them. Particularly, the fuel is highly flammable.



- Do not smoke or use a match or cigarette lighter close to inflammables (combustibles).
- When refueling, stop the engine and do not smoke.
- The filler caps of the fuel and oil tanks must be kept tight.



■ Ensuring safety in a fire

- Machine fires may cause serious injuries or death, so stop the engine by turning the starter switch to the OFF position, then move away from the machine as quickly as possible.

■ While the engine is running or immediately after it has been turned off, do not touch the muffler, exhaust pipe or DPF

- While the engine is running or immediately after it has been turned off, do not touch the muffler, exhaust pipe or DPF, as they will be hot.

■ Mount on or dismount from your machine after it has come to a complete stop

- For getting on and off, face the machine and use the handrail and step.
- Watch your step when getting on or off the machine.
- Do not jump on or off a machine, particularly when it is moving.
- When getting on and off an articulated machine, straighten it out before stopping the machine. In the turned state, there is danger that personnel gets caught because the getting on and off space narrows.

■ Be careful not to fall

- Falling off the machine may cause serious injuries or death, so do not place your feet anywhere other than on the steps, and in the driver's seat.

■ Do not lock out yourself when leaving the machines

- Always bring the key with you by pulling it out from the starting switch when leaving the machine.

1 BASIC PRECAUTIONS FOR SAFETY

■ To handle the hydraulic fluid

- Wear safety goggles to protect your eyes from contact with hydraulic fluid. It can irritate your eyes.
If the fluid contacts your eyes, flush with clean water for 15 minutes and get medical aid.
- The fluid can also irritate your skin. When handling it, wear rubber gloves to avoid contact with it. In case of skin contact, wash with soap and water.
- Be careful not to swallow the fluid. It can cause diarrhea and emesis.
If swallowed, do not try to vomit. Get medical help immediately.



■ Do not use worn tires (Tire installed)

- Tires may be damaged when they are scratched on curb stones, when the machine runs over irregular surfaces of roads or projections on roads, and when the machine is operated suddenly.
- Continued use of damaged tires will cause them to blow out. Replace them with new ones.

1.2 Preparation for Safe Operation

■ Clean the step, operator's station and floor board and brake pedal

- Do not place parts, tools or unnecessary articles on the step, operator's station and floor board.
- Keep the step, floor board, brake pedal, controls and handholds free from muds, oil, ice or water, as they can cause slippage. Repair them if found to be damaged. Tighten loose bolts.
- Keep your boot soles free of oil or muds. They can slip, leading to an accident.

■ Inspect your machine before operation

- Check your machine for damage such as cracks and deformation. If found to be abnormal, operate the machine after taking a proper measure to secure safety.
- Check the level of fluids (fuel, engine oil, coolant, antifreeze and hydraulic oil). Add as necessary.
- Check the area where the machine has parked for signs of leakage of oil, fuel and water. If any leakage is noticeable, determine the cause and make corrections immediately.

⚠ WARNING: Negligence of these instructions can lead to accidents.

1 BASIC PRECAUTIONS FOR SAFETY

■ Watch your distance

- When traveling on a road, bear in mind the stopping distance. Avoid excessive speed, and abrupt starting and stopping, and moving in a zigzag direction.

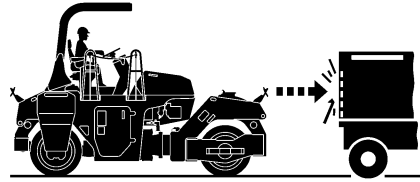

■ Understand ROPS functions (with ROPS)

- Ensure that there is no loose bolt, crack nor rust on the bodies and the attaching portions, of ROPS.
- Tighten bolts with the specified torques after ROPS are removed.
Tightening torque : **539 N·m**
- Do not weld nor drill holes to the ROPS parts without the permissions from SAKAI, because it may decrease strengths of the ROPS.
- Be sure to wear the seatbelt during operation.

1.3 Before Starting the Engine

■ It is confirmed that hood and door is closed

- Please confirm hood and door has put it away in the confirmation before it gets on.

■ Adjust the operator's seat to your most effective operating position

- Sit on the operator's seat. Adjust the seat so that your back will make contact with the seat back when the brake pedal is pressed down to the full extent. Check to be sure that the brake pedal can be fully pressed down without difficulty when you twist your body for reverse run.
- Adjust the seat to allow proper operation of the steering wheel, levers, switches, etc.

■ Secure good visibility (with CABIN)

- Keep the windowpanel clean.
- Lock the windows and doors no matter whether they are open or closed.
- Do not leave the doors half-closed.

■ Secure forward and backward visibilities

- Adjust the rear view mirrors and under mirrors for good visibility. If dirty, clean them. If damaged, replace.

1 BASIC PRECAUTIONS FOR SAFETY

■ Check that the horn, lamps and gauges work correctly

■ Before starting, make certain that each lever is in the neutral position and the parking brake is applied

■ When starting, sound the horn

- Before starting the engine. Make sure there is no one in the immediate vicinity and there are no obstructions around the machine.



■ Sit in the driver's seat and turn on the engine

- Do not start the engine anywhere other than from the driver's seat as there is the danger of operational mistakes.

■ Pay attention to ventilation

- Exhaust fumes are dangerous if breathed in. When starting the engine in an enclosed area, provide good ventilation with windows and doors opened.



■ Do not stand close to the exhaust gas pipe opening

- The exhaust gas from the engine is dangerous.
- Exhaust fumes are harmful if breathed in.

1.4 After Starting the Engine

■ Secure safety around the machine

- Ensure that the area around the machine is clear of personnel and obstructions. Moreover, honk the horn, indicate your intention to move, and wait a while before moving off.



■ Warm up the engine

- Do not put your machine into motion immediately after the engine has started, let it idle for several minutes until it is at operating temperature.
- Check the area where the machine has parked for signs of leakage or oil, fuel and water. If any leakage is noticeable, determine the cause and make corrections immediately.

⚠ WARNING: Negligence of these instructions can lead to accidents.

1 BASIC PRECAUTIONS FOR SAFETY

■ Have a trial run

- Make a test run in a safe place to check that there are no abnormal signs. If found to be abnormal, correct the fault before traveling again.
- Listen for unusual sounds, and check for abnormal temperature rise. If abnormal, park the machine in a safe place and find the source of trouble before operating.

1.5 During Operation

■ Strictly observe the traffic regulations

- Follow all the traffic regulations when driving on a public road.

■ Sit in the driver's seat before starting operation

- Sit in the driver's seat before starting operation. Be sure to wear the seat belt when provided.

■ Seat belt (with seat belt)

- Be sure to wear the seat belt during operation.

■ No other person but the operator

- This machine is a one-man roller. Do not allow anyone to get on. Only the operator is allowed on this machine while it is running or in operation.

■ Before mounting, be sure areas around the machine are safe

- Before getting on the machine, make certain that there are no obstacles around the machine and no workers under it. If some workers are present or close to the machine, tell them that the machine is about to move, warning them to stay away from it.

■ Do not try to get on or off a moving machine

- Get on or off the machine after making sure it has come to a complete stop and the parking brake is applied.

■ Do not let anyone enter the work area

- There is the danger of being run over causing serious injuries or death.
- If the driver does not have a clear field of vision, assign a conductor ensure peripheral safety.

1 BASIC PRECAUTIONS FOR SAFETY

■ To go uphill or downhill, run at a low speed. Do not attempt to shift speeds while traveling on a slope

- Shifting speeds on a slope can cause unexpected running down the slope.
- Going down hill at speeds other than low range can cause the machine to run down violently.

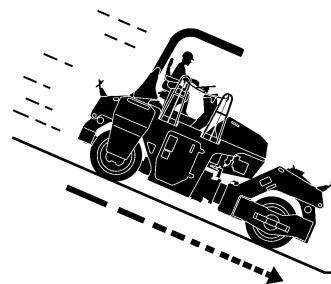

■ Refrain from inattentive driving

- Inattentive driving or driving relying on guess work can cause an accident. Use extreme care for workers present in the path of the roller or around it. In case of danger, stop and sound the horn, and proceed when the area is clear of personnel or obstructions.

■ When changing the direction of travel, secure the safety on the path in the travel direction

■ Keep everyone away from the pinch points

- When making turns, do not allow anyone to come close to the pinch point.

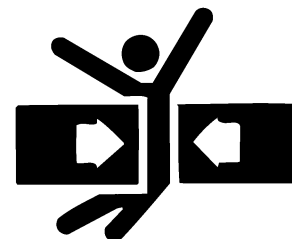

■ At night, carefully drive the machine

- Nighttime driving tends to frustrate the sense of distance. Carefully drive the machine at a speed suited to illumination. Keep the headlamps and flood lamps lighted. If necessary, provide extra lighting in the work area.

■ Avoid long hours of continual operation

- Avoid long hours of continual operation as it may lead to loss of health.

■ Repair as soon as possible if found to be defective

- If the machine is found to be faulty, stop the machine and repair. Do not operate the machine until the problem is corrected. When any warning lamp indicates faulty operation, inspect the machine after moving it to the nearest safe location.

⚠ WARNING: Negligence of these instructions can lead to accidents.

1 BASIC PRECAUTIONS FOR SAFETY

- **The machines not equipped with ROPS must not be operated on the slopes or unsafe ground**

- **The machines not equipped with CABIN must not be operated in the bad weather or a harmful contaminated zone**

- **Do not operate the machine except from the operator's seat. Do not drive in a standing posture**
 - Do not throw your legs out or lean forward. Be sure to sit in the proper position while driving the machine.

- **While making turns, do not run at abnormally high speed and do not turn the steering wheel abruptly and sharply. High speed turns, especially on soft or uneven ground, could result in a rollover**

- **For the traveling on structures such as a bridge, make certain that they can support your machine. Before traveling on the structure, you must know the load capacity of the structure and the load weight of the machine you are operating to insure safe travel across the structure**

- **Do not make turns on a slope and do not travel across sidehill. If necessary to do so, go down straight along the slope to the flat ground, move sideways and go up straight to the destination**

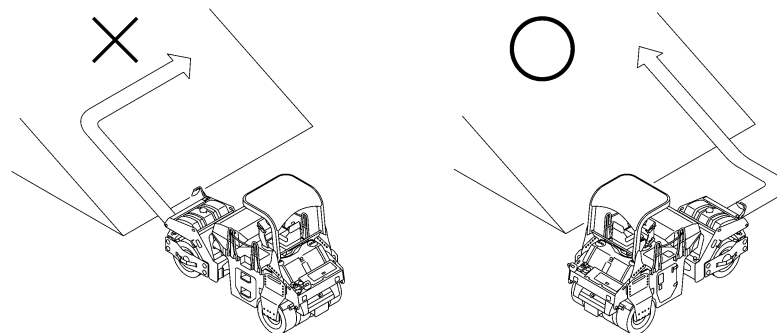

1 BASIC PRECAUTIONS FOR SAFETY

■ On a steep slope, run the machine at low speed

■ When parking

- Select level and hard ground. If necessary to park on a slope, chock the front of the drum and tire on the downside of the slope.
- When required to park on the public road, provide necessary markings such as flag, barriers and illumination. However, be sure they do not obstruct traffic.
- Stop the engine when getting off the machine. Remove the key from the starter switch, and make sure it is stored appropriately.
- Be sure not to get your hands caught in the chocks when handling them.

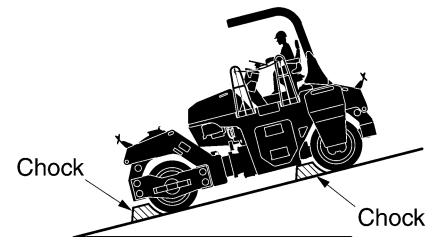

1.6 Loading and Unloading

- Loading and unloading can accompany any danger. Use extreme care.
- Select level and hard ground leaving a sufficient distance from the shoulder of a road or bank.
- Use sturdy ramps with proper width, length and thickness which allow safe loading and unloading. If they deflect considerably under load, apply wooden blocks to reinforce the ramps.
- To prevent your machine from crosswise slippage, keep the ramps free from oil, mud, debris, etc. The drum must also be free from extraneous matter that can cause slippage.
- Do not steer your machine on the ramps. If the machine is facing in the wrong direction, go back off the ramp, correct the direction and try again.
- Do not use kinked, twisted or damaged wireropes for crane or winch operation. Use ones with ample strength.
- When loading is complete, fix the machine with wooden blocks placed under the drums and chains fastened to the machine.

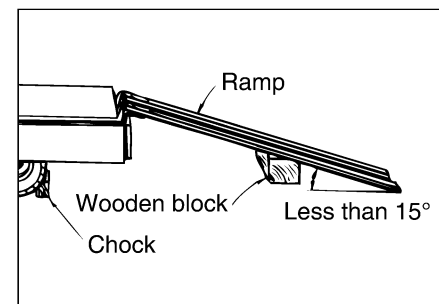

1.7 Transportation

- Follow required regulations.
- Select a transporting route according to the overall width, overall height and gross weight of the trailer with the machine loaded.
- Know the maximum height clearance of the machine loaded on the transport trailer before hauling under bridges and other structures.

⚠ WARNING: Negligence of these instructions can lead to accidents.

1 BASIC PRECAUTIONS FOR SAFETY

1.8 Handling the Battery

■ When handling the battery

- Battery electrolyte contains sulphuric acid. It will destroy clothing and skin. If it touches your clothing or skin, flush with large quantities of water.
- In case of eye contact, flush with clean water and get medical help.
- If swallowed, drink large amount of water, milk, beaten egg or vegetable oil, and get medical help.
- Wear safety goggles when handling the battery. Wear safety goggles, full face shield, rubber gloves and rubber apron when adding fluids to the battery.
- Keep cigarettes and flames away, and avoid recharging the battery in poorly ventilated places when there is a danger or generating sparks.



⚠ WARNING

Battery posts, terminals, and related accessories contain lead and lead compounds, chemicals known to the State of California to cause cancer and reproductive harm. Wash hand after handling.

- Inspect or handle the battery with the engine stopped and the starter switch in the OFF position.
- Keep metallic items such as tools away from the battery terminals.
- Tangled terminals may generate sparks due to improper connections, resulting in the danger of explosions. Make sure terminals are connected firmly.
- The battery is for starting the engine and operating electrical equipment on the machine. Do not use it for any other purpose.
- Do not charge battery when the top surfaces of the liquids are at the LOWER level (the minimum liquid level) or below. Not only the internal parts of the battery are degraded and the battery lifetime are shortened but also it can cause explosions if you continue on using the battery when the top surfaces of the liquids are at the LOWER level or below. Immediately supply water until the water level is between the UPPER and LOWER levels.

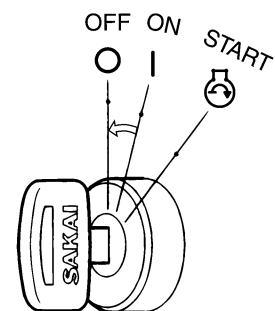

1 BASIC PRECAUTIONS FOR SAFETY

■ Jump-starting the engine

- Wear safety goggles when jump-starting the machine.
- When starting from another machine, do not allow the two machines to make contact with each other.
- When connecting the battery cables, start with the positive terminal. For disconnection, start with the negative one.
- Do not allow a tool to bridge between the positive terminal and machine body. This can generate dangerous sparks.
- Do not connect the booster cable to wrong the terminal. Never connect the positive terminal to the negative terminal or the body of the machine.
- Final connection to the engine block of the disabled machine can cause sparks. The connecting point should be as far as possible from the battery.

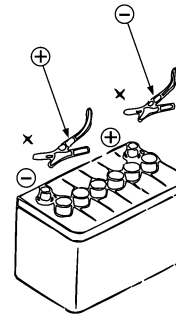

1.9 Towing

- Towing should only be carried out in emergencies and over short distances. A trailer should be used for long distance transport.
- The machine should not be operated while being towed.
- Follow the instructions in this manual to enable towing.
- Do not tow if the braking system has broken down, as it is dangerous.
- To tow the machine, use cables with ample strength.
- Do not perform towing on a slope.
- Be sure to attach a wire rope firmly to the towing hook.
- Do not use twisted, kinked or damaged cables when towing.
- Do not step over the wire rope.
- Keep everyone away from the space between the machine and the towing machine when connecting the two.
- Align the connection points of the disabled machine and the towing machine in a straight line when connecting the machines.

⚠ WARNING: Negligence of these instructions can lead to accidents.

1.10 Before Servicing

■ Attach warning tags when servicing the machine

- Serious accidents can occur if the machine is unexpectedly started or controls carelessly touched by an unauthorized person.
- Attach a warning tag at a clearly visible location in the operator's station and insure the key has been removed from the starter switch.



■ Setting the chocks

- Set chocks in front of and behind the roller drum (wheels) to prevent the machine from moving before beginning inspections or maintenance work.

■ Use proper tools

- It is very dangerous to use damaged or deteriorated tools or to use tools for other purposes than intended. Use correct tools for their intended use only.



■ Change safety-related parts at regular intervals

- Change any seatbelt found to be abnormal even if it is within its recommended service interval.
 - Change any ROPS found to be abnormal even if it is within its recommended service interval.
 - Replace fuel hose, high pressure hydraulic hoses and liquid hoses regularly to prevent fire. Replace high pressure hoses of the power steering system every two years.
- ☆ Change these parts at regular intervals even if found to be normal. They will deteriorate as time goes on.
- ☆ Change any hose found to be abnormal even if it is within its recommended service interval.

1 BASIC PRECAUTIONS FOR SAFETY

■ Inspect or service your machine with the engine stopped

- If required to keep the engine running in such a case as radiator interior cleaning, perform the work with two persons. One of them should sit on the operator's seat getting ready for shutting down the engine. He must take care not to touch any of controls carelessly. Maintenance personnel must exercise extreme caution not to make contact with moving parts.

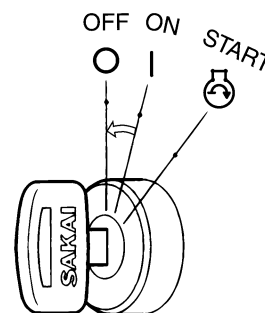

■ Supplying fuel, oils and grease

- Do not cover the filler port when refueling. Feeding fuel in an airtight tank might damage the fuel tank.
- Spilled fuel or oil will be slippery. Wipe up immediately. Keep the filler caps tight. Do not use fuel for flushing oil. Handle fuel and oil in a well ventilated area.

■ Check the coolant level in the radiator

- To check the coolant level, stop the engine and allow the engine and radiator to cool down before removing the radiator cap. Remove the cap by covering it with a rag before removing to prevent any fluid that could spray under pressure from causing a burn.

■ Illumination

- For inspecting the level of the fuel, oil, coolant and battery electrolyte, use explosion-proof illuminations. Failure to use this type of illumination can result in an explosion.



■ Make sure the gas dampers are properly maintained

- Before inspecting the engine room, make sure the gas dampers holding up the hood are firmly engaged. Furthermore, in machines with stays to prevent the hood from closing, make sure they are firmly in place.

■ Points to beware of when filling the sprinkler tank with water (on machine equipped with a sprinkler tank)

- Do not fill the tank with the water inlet blocked. It may damage the sprinkler tank.

⚠ WARNING: Negligence of these instructions can lead to accidents.

1 BASIC PRECAUTIONS FOR SAFETY

1.11 During Servicing

■ Keep unauthorized persons away

- During service, do not allow persons not concerned to enter the work area, particularly when grinding or welding operation is performed or heavy hammers are being used.



■ Assume an appropriate posture while working

- An unnatural posture during maintenance work may cause injuries. Assume a posture that is appropriate for the work being carried out.

■ Keep your machine clean

- Spilled oil, grease or scattered debris are dangerous. Always keep your machine clean. Moisture that penetrates into the electrical system can cause malfunctions. Do not use water to clean sensors, connectors and the operator's station.

■ Take care not to get caught or crushed

- Be sure to fix the hood and other covers after opening them to prevent closing and avoid getting caught in them.
- If there is a need to crawl under the machine after it has been lifted, be sure to support it from underneath with a solid prop or block.

■ When repairing the electrical system

- Read the warnings in this manual regarding the handling of batteries, and make sure to have a thorough understanding in order to handle them appropriately and safely.
- When repairing the electrical system or welding, disconnect the negative cable from the battery to shut off the electricity. Carrying out work while the cables are connected to the negative terminal may cause electrocution or explosions.



■ Carefully handle high pressure hoses

- Do not try to bend or hit hoses against a hard object. Do not use hoses or pipes that are bent or damaged. They will burst.
- Replace damaged fuel hose, hydraulic hoses and liquid hoses. An oil, hydraulic and liquid fluid spill can cause a fire.

1 BASIC PRECAUTIONS FOR SAFETY

■ Be careful of high pressure hydraulic fluid

- Bear in mind that the working equipment hydraulic systems are under internal pressure. Do not perform adding, draining, inspection or servicing of the hydraulic systems until the internal pressure has been relieved. Hydraulic fluid leaking through a fine hole at high pressure can penetrate your skin and eyes. Inspect leakage by holding a hard board close to suspected leaks wearing goggles. If affected by high pressure oil, get medical help immediately.

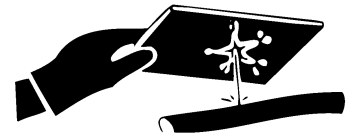

■ Be careful of hot parts

- After the machine has been operated for some time, the coolant, engine oil and hydraulic fluid will become hot.
- Removing the radiator cap or draining the coolant or oil can burn you. Perform this work in accordance with correct procedures after the systems have cooled down.



■ Use care when inspecting or servicing fan or belts in motion

- Do not wear clothing and accessories that tend to get caught in moving parts.
- Do not let your body or tools make contact with the fan blades or belts. They can be cut seriously.



■ Used oil disposal

- Do not throw used oil into a drain or waterway. Drain the oil from the machine into a proper container. Do not drain directly on the ground.
- Obey all local, state and federal environment regulations for the proper disposal of oil, fuel, coolant, battery electrolyte or any other fluids.

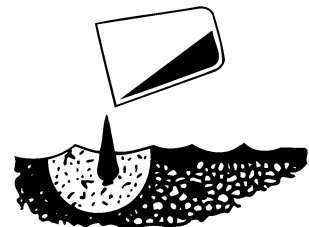

⚠ WARNING: Negligence of these instructions can lead to accidents.

1 BASIC PRECAUTIONS FOR SAFETY

■ Take care in handling the gas damper

- Never dismantle it.
- Do not throw it into a fire.
- Do not damage the rod.
- Do not bend the tube or rod, or use it as a handle.
- When disposing of it, be sure to fix the gas damper, and drill a hole around 2 to 3 mm in diameter, about 20 to 30 mm from the edge on the tube bracket side. Dispose of it after releasing the gas pressure. When doing this, be sure to wear protective goggles because of the danger of oil inside or swarfs getting sprayed everywhere by the compressed gas inside.

■ Exercise extreme care when replacing and repairing tires (Tire installed)

- Disassembly, repair and reassembly of tires require special facility and knowledge. Have them repaired at work shop specialized in handling tires.
- An improperly fitted tire can separate from the rim when inflating.
- When dismounting a tire, chock other tires for safety.
- When welding job is carried out near the tires, use extreme care, as this can cause an explosion of the tires.



1 BASIC PRECAUTIONS FOR SAFETY

1.12 Safety Decals

Keep all decals clean. If lost, replace with new one. There are decals other than those shown below: Treat them in the same manner as the one shown here.

① 3998-16624-0 (3 locations)

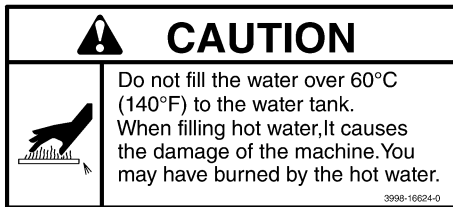

② 3998-16668-0

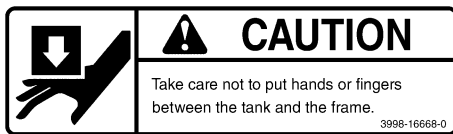

③ 3998-16696-0

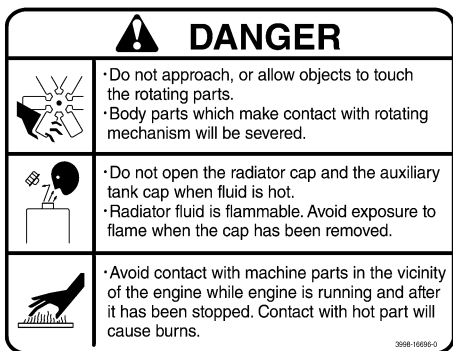

④ 3998-16499-0 (2 locations)

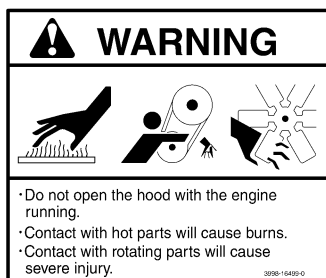

⑤ 3998-16680-0

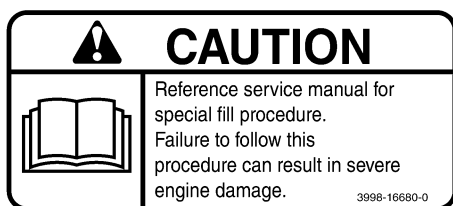

⑥ 3998-16684-0 (3 locations)



⑦ 3998-16750-0

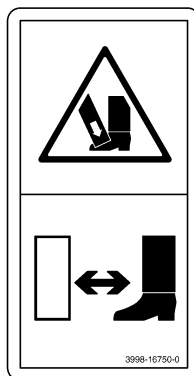

⑧ 3998-16748-0 (2 locations)

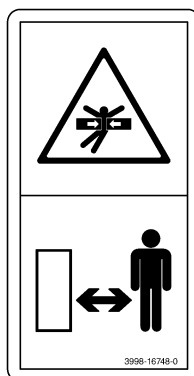

⑨ 3998-16500-0

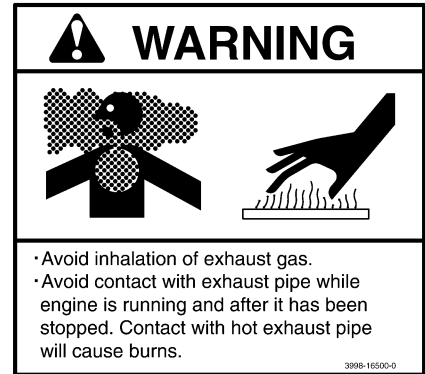

⑩ 1539-19005-0

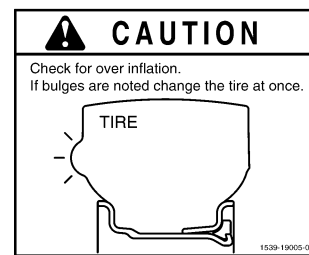

⑪ 3998-16559-0

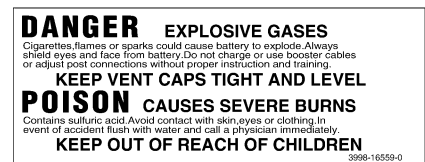

⑫ 1418-19109-0

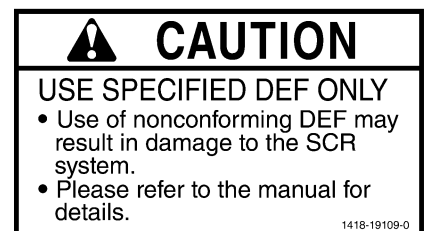

⑬ 2998-96001-1

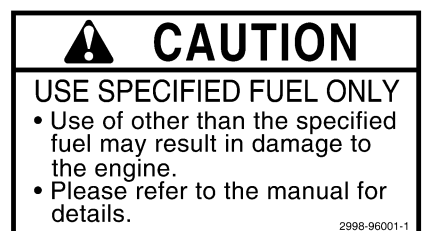

⚠ WARNING: Negligence of these instructions can lead to accidents.

1 BASIC PRECAUTIONS FOR SAFETY

⑭ 3998-16501-0

⚠ DANGER	
	
<p>Be Careful with Fire</p> <ul style="list-style-type: none"> ·When refueling, stop the engine and do not ·The filter cap of the fuel tank must be 	
<small>3998-16501-0</small>	

⑮ 3998-16536-0

⚠ DANGER	
	<ul style="list-style-type: none"> ·Avoid contact with the machine parts in the vicinity of the engine while engine is running and after it has been stopped. Contact with hot parts will cause burns.
<small>3998-16536-0</small>	

⑯ 3998-16489-0

CALIFORNIA
Proposition 65 Warning

Diesel engine and some of its constituents are known to the State of California to cause cancer, birth defects, and other reproductive harm.

3998-16489-0

⑰ 1568-19011-1

⚠ WARNING
<p>1. This vehicle may malfunction from a strong electromagnetic wave in its neighboring environment. Control is maintained using electronics. Do not use this vehicle in an environment that may expose it to a strong electromagnetic wave. Do not use a device with a strong electromagnetic wave on or near this vehicle.</p> <p>2. Electronics on this vehicle emit a minor electromagnetic wave. Do not operate this vehicle if you wear a pacemaker. Long term operation may cause damage to your health from the electromagnetic wave.</p>
<small>1568-19011-1</small>

⑱ 3998-16700-0

⚠ WARNING
<p>Be careful with DPF regeneration (automatic or manual cleaning)</p> <ul style="list-style-type: none"> ·Avoid inhalation of exhaust gas. ·Do not DPF regeneration in an enclosed area. ·To avoid a fire, make sure there is nothing flammable around exhaust opening and muffler. ·Do not approach without contacting while DPF is regenerating and it has been stopped.
<small>3998-16700-0</small>

⑲ 3998-16730-0

⚠ CAUTION
<p>Cautions on DPF Parked RGN Please stop in without turning off the handle. The exhaust is not hit to people and vehicles. It will lead to burns and damage of vehicles.</p>
<small>3998-16730-0</small>

⑳ 3998-16737-0

⚠ CAUTION
<p>Cautions on DPF Parked RGN Don't operate the FNR lever, throttle lever, parking switch and the steering wheel while the parked RGN is in process.</p>
<small>3998-16737-0</small>

㉑ 3998-06139-0

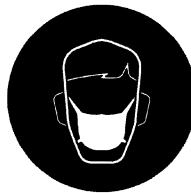

㉒ 3998-16505-0

⚠ DANGER
<p>Roll Over Prevention</p> <ul style="list-style-type: none"> ·Do not work in the vicinity of overhanging banks, or on grades steep enough to cause the machine to slide or roll over. ·Reduce speed prior to making turns. ·Pay particular attention when operating on uneven surfaces, as the machine may become unstable.
<small>3998-16505-0</small>

㉓ 3998-16646-1

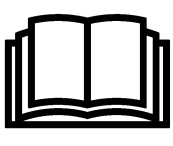
	
<small>3998-16646-1</small>	

㉔ 1439-19016-0

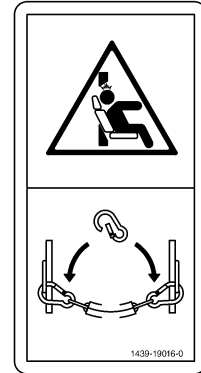

㉕ 3998-16504-0

⚠ WARNING
<p>1. When Handling the Machine:</p> <ul style="list-style-type: none"> ·Operate only while seated. ·Use the handrails and steps when boarding and getting off. ·Never carry passengers. ·Never attempt to board or get off the machine while it is moving. <p>2. Preparation for Safe Operation</p> <ul style="list-style-type: none"> ·Clean the steps, operator's station and floorboards. ·Obey the worksite rules. ·Sakai accepts no responsibility for any injury or damage to the machine caused by unapproved modification. ·Do not use a machine which needs repair or maintenance. ·Sound the horn immediately prior to starting the engine to warn people in the vicinity. <p>3. Starting the Engine</p> <ul style="list-style-type: none"> ·Check that all operating levers are in the neutral position. ·Idle the engine for about 5 minutes to warm it up prior to commencing work. <p>4. Parking Precautions</p> <ul style="list-style-type: none"> ·When parking the machine, park it on level ground, set the parking switch and set the roller chocks. ·Allow the engine to cool off by running it for about 5 minutes before stopping. ·When getting off the machine, remove the key from the ignition switch.
<small>3998-16504-0</small>

㉖ 3998-16511-0

⚠ WARNING
<p>Replace the power steering high pressure hoses every two years.</p>
<small>3998-16511-0</small>

㉗ 1539-19003-0

⚠ CAUTION
<p>Do not sprinkle water on electrical equipment because it causes the breakdown.</p>
<small>1539-19003-0</small>

⚠ WARNING: Negligence of these instructions can lead to accidents.

1 BASIC PRECAUTIONS FOR SAFETY

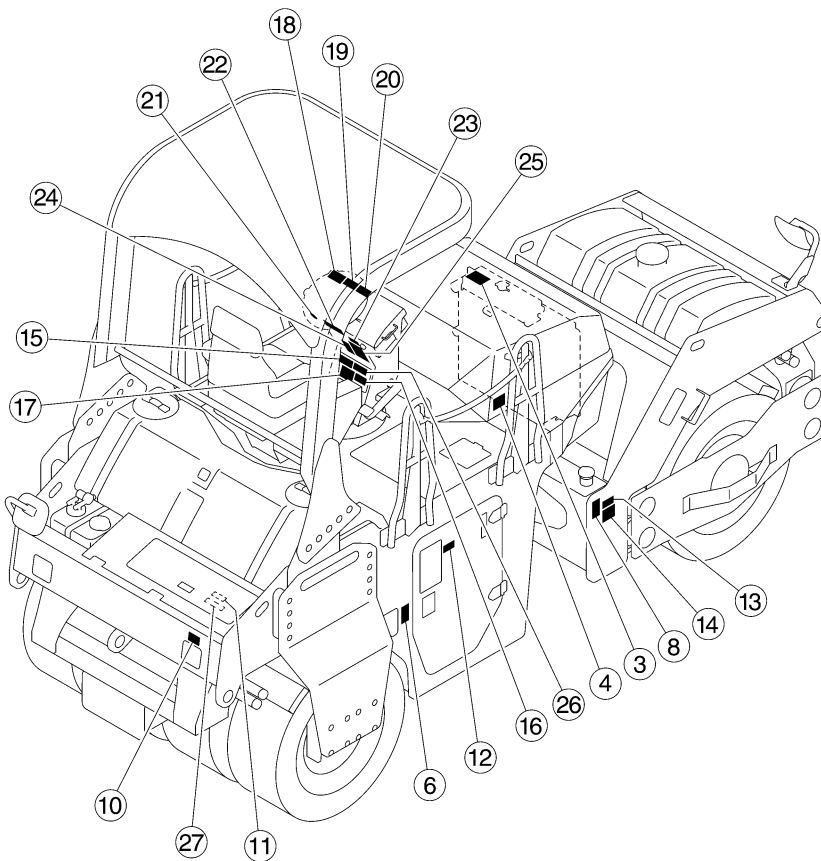
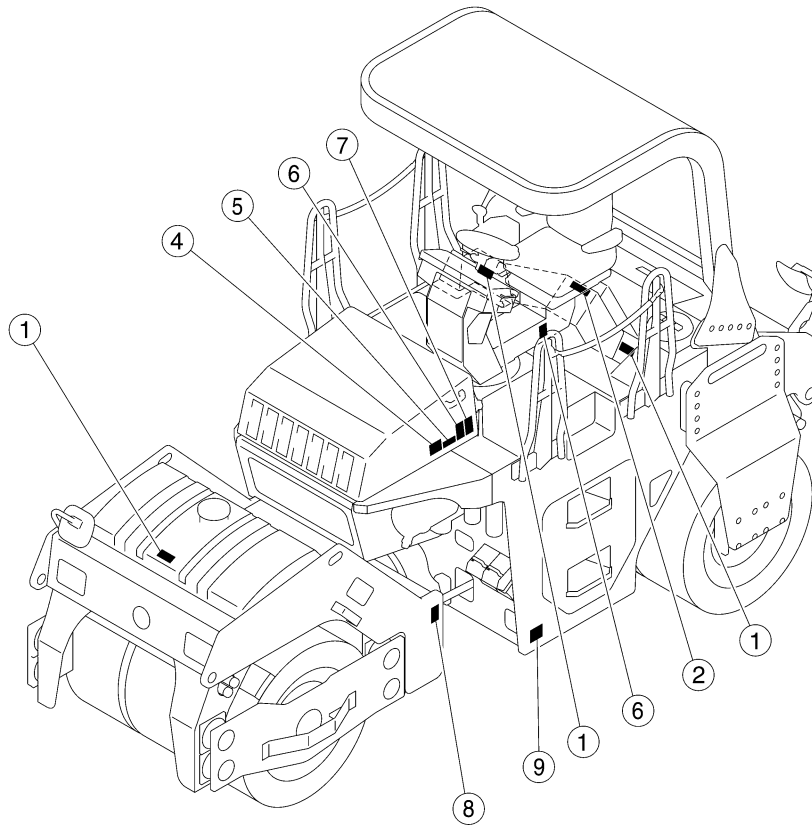

2 OPERATION

2.1 Instruments and Controls

2.1.1 Operator's station

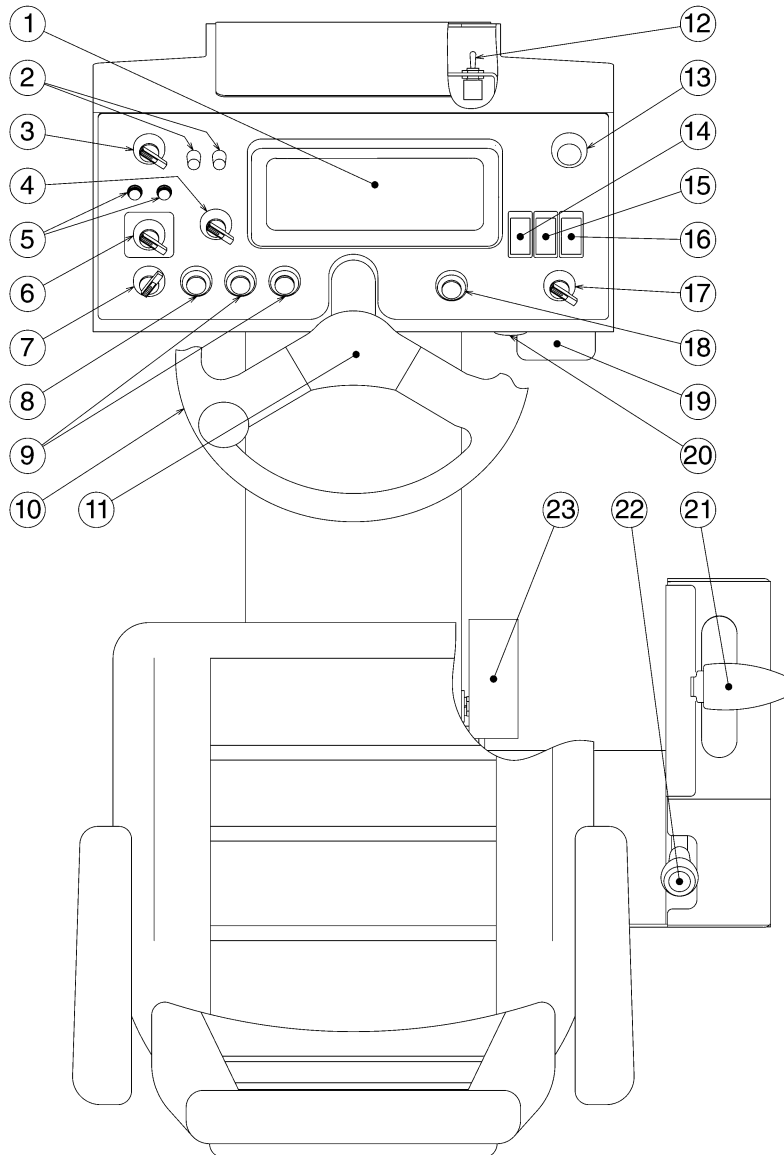

- | | | |
|----------------------------------|--------------------------------|--|
| ① Combination meter | ⑨ Sprinkler switch | ⑱ Parked manual regeneration switch |
| ② Sprinkler timer | ⑩ Steering wheel | ⑲ Brake pedal |
| ③ Vibration mode selector switch | ⑪ Horn switch | ⑳ Starter switch |
| ④ Sprinkler selector switch | ⑫ Engine diagnostic switch | ㉑ Forward-Neutral-Reverse (F-N-R) lever with vibrator switch |
| ⑤ Vibration indicator lamp | ⑬ Parking brake switch | ㉒ Speed shift lever |
| ⑥ Vibration switch A | ⑭ Flood lamp switch | ㉓ Swivel release pedal |
| ⑦ Vibration switch B | ⑮ Dimmer switch | |
| ⑧ Liquid spray switch | ⑯ Lamp switch | |
| | ⑰ Engine speed selector switch | |

2 OPERATION

2.1.2 Gauges, indicator lamps and warning lamps

For safe execution of your job, fully understand the role and function of the systems involved.

Combination meter

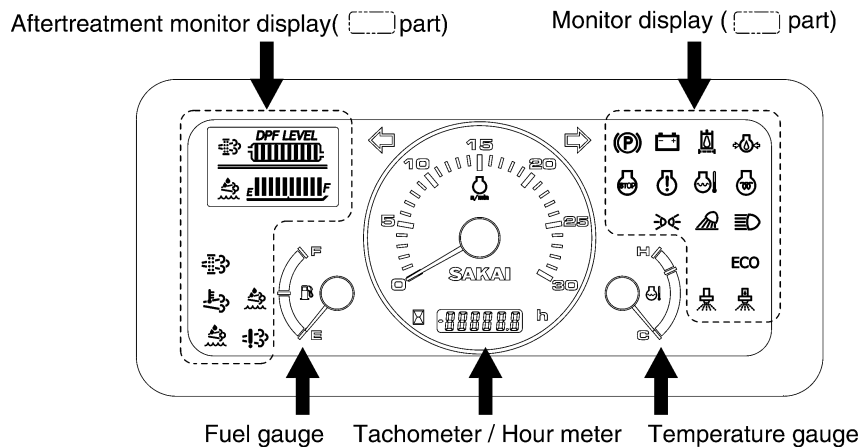

Tachometer / Hour meter

Indicates the engine RPM. The hour meter shows total operating hours. The service interval recommendation in this manual should be based upon the hour meter readings.

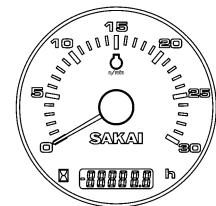

Tachometer / Hour meter

Temperature gauge

Indicates the coolant temperature. Zone close to symbol H indicates overheating. In case of overheating, run the engine at idling for about ten minutes before shutting it down. Then determine the cause.

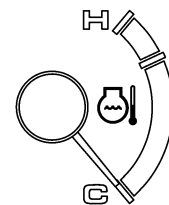

Temperature gauge

Fuel gauge

Indicates the fuel level in the tank.

E: The tank is empty.

F: The tank is full.

Replenish fuel appropriately before the fuel runs down.

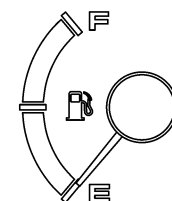



Fuel gauge

⚠ CAUTION

Be sure to use fuel recommended by SAKAI (refer to page 109).

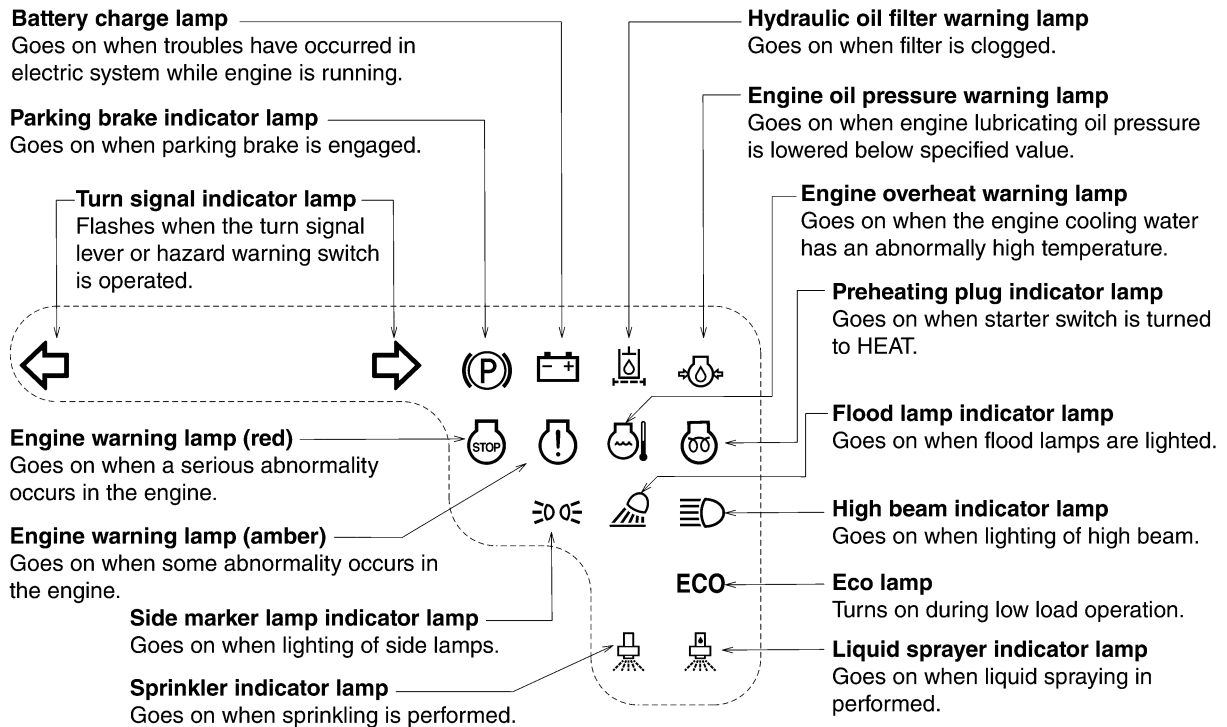
Monitor display



★ Indicator lamps [    ]
Light up when corresponding systems have been operated.

★ Parking brake indicator lamp []
It will flash once when the starter switch is turned to the ON position.
After that it will remain on while the parking brake is engaged, and turn off when it is released.

★ Hydraulic oil filter warning lamp []
It will flash once when the starter switch is turned to the ON position.
After that it will turn on when the hydraulic oil filter becomes clogged. Stop the machine and carry out an inspection.

★ Engine oil pressure warning lamp []
It will turn on when the starter switch is turned to the ON position, and turn off when the engine starts running.
It will turn on while the engine is running if the engine oil pressure drops below the specified value. Stop the machine and carry out an inspection.

★ Battery charge lamp []
It will turn on when the starter switch is turned to the ON position, and turn off when the engine starts running.
It will turn on while the engine is running when a problem arises with the electric system. Stop the machine and carry out an inspection.

2 OPERATION

★ Engine stop lamp (red) []

It will turn on when the starter switch is turned to the ON position, and turn off when the engine starts running.

When the Engine warning lamp lights, it means a serious abnormality occurs with the engine.

★ Engine warning lamp (amber) []

It will turn on when the starter switch is turned to the ON position and turn off when the engine starts running.

Turns on while the engine is running when there is a problem with the engine system. If it turns on, park the machine in a safe place, stop the engine, and contact one of our sales offices or a factory designated by our company for advice.

★ Engine overheat warning lamp []

It will turn on when the starter switch is turned to the ON position, and turn off when the engine starts running.

Turns on when the engine overheats. If it turns on, there is a possibility of overheating regardless of the thermometer reading. Park the machine in a safe place, stop the engine, put the throttle lever in the idling position, and let the engine idle to gradually cool it. If the lamp does not turn off, contact one of our sales offices or a factory designated by our company for advice.

★ Preheating plug indicator lamp []

It will turn on automatically if preheating is required when the starter switch is turned to the ON position.

Turns off when preheating is completed.

IMPORTANT

• Hydraulic oil filter warning lamp

The warning lamp may turn on when the engine revved up before it has warmed adequately.

Warm the engine adequately, and operate the machine after the lamp has turned off.

• The window of the combination meter

The window of the combination meter may become invisible because of aged deterioration caused by fine sand or dust or ultraviolet. When any flaw or mist is found on the window, contact our branch offices or designated factory.

• If the engine warning lamp or engine stop lamp do not turn off after starting the engine, or these lights turn on while driving, the engine has broken down or there is an error. Check to see if the problem can be identified.

NOTE: When the flood lamp turns on, start the engine after it has turned off.

Post-processing equipment display monitor

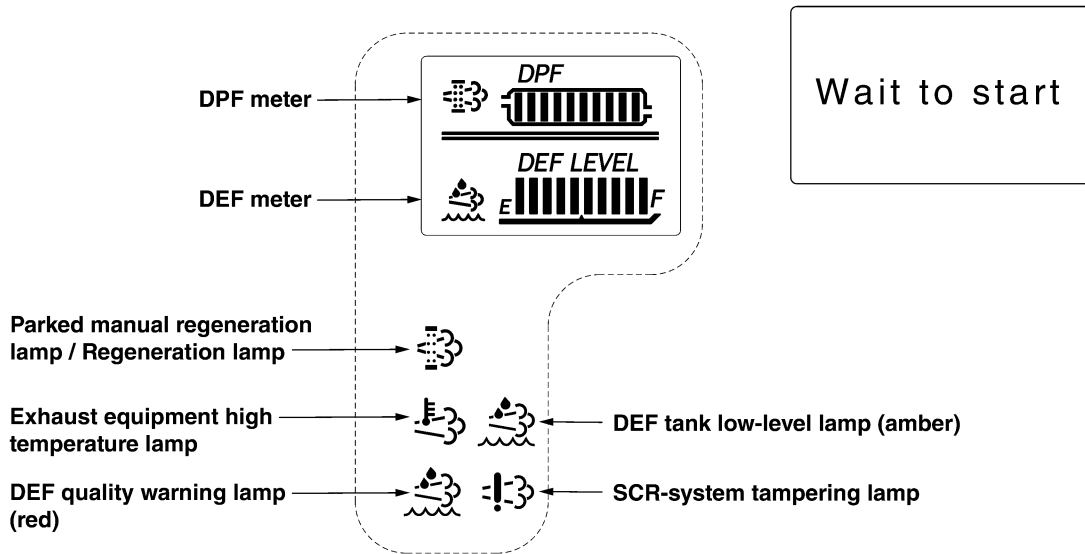

★ DPF meter

This meter indicates the amount of PM (particulate matter) that has accumulated on the DPF (diesel particulate filter).

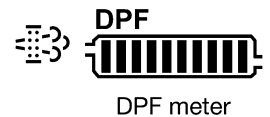

★ DEF meter

Indicates DEF level in DEF tank
 E: Indicates there is no DEF left
 F: Indicates tank is full

Do not use DEF until tank is empty, but fill it up regularly. Refer to Operating the DEF SCR System for more details.



⚠ CAUTION

- Using the machine when the DEF level is low will sound the buzzer, and the warning lamp will turn on or flash. A limit will also be placed on the engine output, not allowing the machine to perform to its full potential. Never use the machine in such a state.
- Use AUS32 for the DEF, or an ISO 22241-1 certified DEF. Do not use anything else. If any kind of additive or water is mixed into the DEF, the machine will not be able to function properly, and it will not satisfy exhaust gas emissions standards. It will also damage the engine system. If the tank is filled with any fluid other than DEF, contact one of our sales offices for advice.

2 OPERATION

★ DPF indicator lamp (amber)

Turned on : Indicates that DPF regeneration is being carried out automatically or manually.

Flashing : Indicates that PM (particulate matter) has accumulated in the DPF, and regeneration is required after parking.



DPF indicator lamp (amber)

★ Exhaust temperature indicator lamp (amber)

Turned on : Turns on when PM (particulate matter) accumulated in the DPF is being burned.



Exhaust temperature indicator lamp (amber)

★ DEF tank low level lamp (amber)

Turns on or flashes when the DEF level in the tank falls below the standard level.



★ DEF quality warning lamp (red)

Turns on or flashes when the DEF concentration is below the minimum required value, or something other than DEF is detected.

It may also turn on when the DEF concentration approaches the minimum required value.



★ SCR-system tampering lamp

Turns on or flashes when the faults of SCR-system is detected.

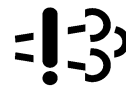

★ WAIT TO START

When the wait to start is lit on the monitor display, it means self-diagnosis of the engine, and the engine should not be started.

Must wait to start the engine. The most common reason for this is to wait for the intake air heaters to complete a pre-heat cycle during cold ambient conditions.

Wait to start

2.1.3 Switches

Starter switch

Starts and stops the engine.

OFF : The key can be removed in this position. All the electric systems are switched off. To shut down the engine, move the key to this position.

ON : The charging circuit and lamp circuit are charged with electricity. Let the key stay in this position after the engine has started.

START: The engine is cranked and gets started. The moment the engine has started, release the key. It will automatically return to the ON position.

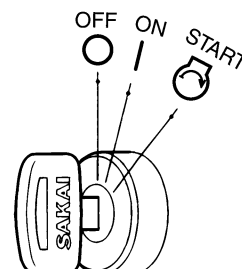

⚠ CAUTION

Set the Forward-Neutral-Reverse (F-N-R) lever in the neutral position and press down the parking brake switch before starting the engine. Unless these conditions are met, the engine will not start.

Lamp switch / Dimmer switch

Has three positions.

OFF : All lamps are switched off.

SIDE MARKER LIGHT : The monitor display light will turn on.



: Head light come on.

Turn on dimmer switch to switch over the upper beam and the lower beam of headlight.

 : The upper beam of headlight lights up.

 : The lower beam of headlight lights up.

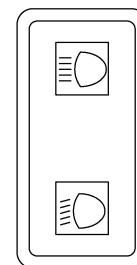

Dimmer switch

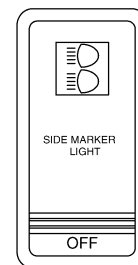

Lamp switch

2 OPERATION

Flood lamp switch

Blank position : Flood lamps on the back of the machine turn off.

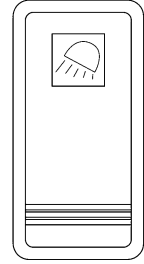

 position : Flood lamps on the back of the machine turn on.



Parking brake switch

Use it as a parking brake.

Do not use while the machine is moving.

If switch  is pressed down, the parking brake applies with the indicator lamp  on the monitor display lighted up.

When pressed again, the brake is released and the indicator lamp goes off.

WARNING

- To disengage the brake, be sure to press the button again instead of pulling it.
- When dismantling from the machine, press the button to apply the brake without fail.

CAUTION

Never pull the switch up.

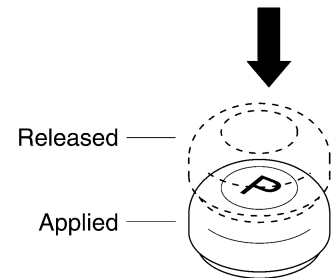

Engine speed selector switch

Shifts the engine RPM.

Engine speed	IDLE	MIDDLE	FULL
	1000 min ⁻¹	1900 min ⁻¹	2400 min ⁻¹

(± 50 min⁻¹)

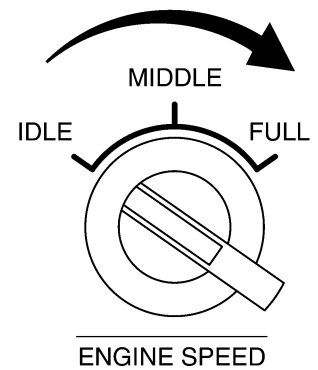

Engine speed selector switch

Horn switch

Pressing the button at the center of the steering wheel makes the horn sound.

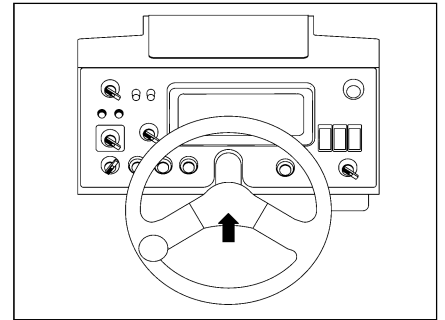
**Vibration switch**

Turns on / off vibration ON-OFF and changes vibration amplitude.

When operating at vibration 2 to 4, changeover the vibration switch A first while the vibration switch B is kept at 2 to 4. Switching from 1 to 4 causes vibration at higher amplitude.

Vibration 1 operates even in stop state if the engine speed is MIDDLE or FULL position, but vibration 2 to 4 operates only while moving forward or backward.

When the forward-reverse lever is placed in the neutral position during rolling compaction work at vibration 2 to 4, return is made to the amplitude of vibration 1. Tilting the lever again resets the amplitude to the selected one of 2 to 4.

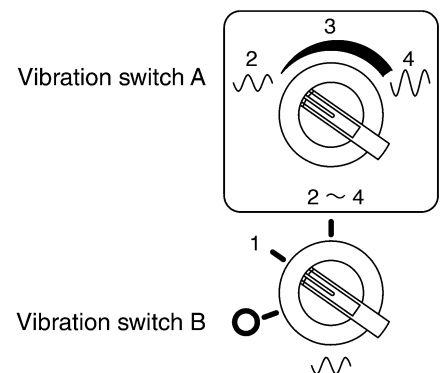
**IMPORTANT**

- **Avoid long-time vibration at vibration 1 while the machine stops.**
- **If traveling becomes impossible due to mud, etc. during vibration rolling compaction, immediately stop vibration.**
- **Because of the characteristic of the amplitude selector system, switching to lower amplitude such as from 4 to 3 or from 3 to 2 cannot be sensed, and in order to switch to lower amplitude, therefore, turn the amplitude selector switch to “OFF” once, and then select the amplitude again.**

NOTE: The vibration rolling compaction, the Engine speed selection switch must be in the MIDDLE or FULL position.



2 OPERATION

Vibration indicator lamp

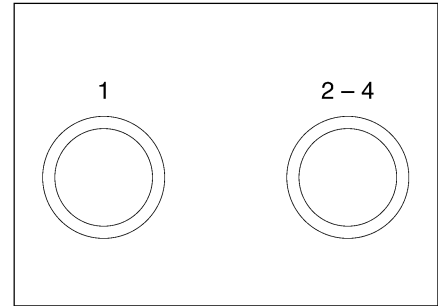
At vibration 1, the vibration indicator lamp on the left side lights and at 2 to 4, two indicator lamps, right and left, light.



Vibration mode selector switch

-  position: Vibration can be controlled by the vibration switch on the F-N-R lever
-  position: Vibration is shut off
- AUTO position: Vibration automatically engages when the F-N-R lever is moved into the forward or reverse

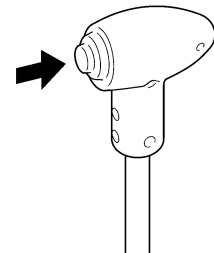
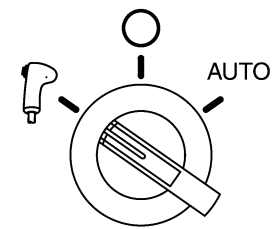

Vibration switch

Sprinkler switch / Sprinkler selector switch / Sprinkler timer

- The sprinkler switch, sprinkler selector switch and sprinkler timer are both used for sprinkler operation.
- Sprinkler switches ① ② (PUMP A and PUMP B) to activate the sprinkler pump for sprinkling.
- PUMP A draws water from the front tank and sprinkles it on both the front and rear drums.
PUMP B draws water from the Rear tank and sprinkles it on both the front and rear drums.
If the sprinkled amount is inadequate, use PUMPS A and B simultaneously.

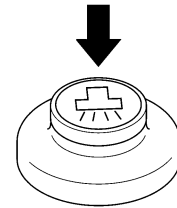

Sprinkler switch ①②

- If the front tank becomes empty, using the tank selection valve allows PUMP A to draw water from the rear tank.
- Sprinkler selector switch ③ selects sprinkler modes; continuous sprinkling mode and intermittent sprinkling mode.

CONT. : Continuous sprinkling is performed.

AUTO : Spraying is done interlocking with forward / backward movement.

TIMER : Intermittent sprinkling takes places.

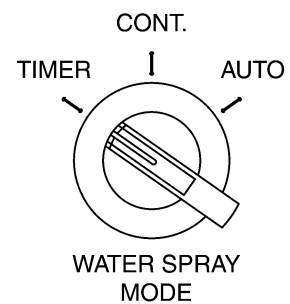

Sprinkler selector switch ③

- For the intermittent sprinkling, set the sprinkler timer at the desired sprinkling duration and idling duration (SPRAY dial ④, PAUSE dial ⑤). Then turn sprinkler selector switch ③ to the TIMER position. Sprinkling will start.

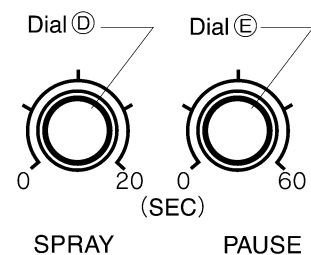

- Sprinkling duration can be adjusted within 0 – 20 seconds with dial ④ . Idling duration can be set within 0 – 60 seconds by turning dial ⑤ .

- Adjust the dials to meet job conditions.

The sprinkler indicator lamp stays bright as long as the sprinkling is being performed.

2 OPERATION

- The table below serves as a guide for sprinkling and idling durations.



Machine speed km/h (mile/h)	Sprinkling duration (seconds)	Idling duration (seconds)
2 (1.2)	7 – 8	35 – 40
3 (1.9)	4 – 5	30 – 35
4 (2.5)	3 – 4	25 – 30
5 (3.1)	2.5 – 3.5	20 – 25

- For normal operation (3 km/h, 1.9 mile/h), use the sprinkler with a sprinkling duration of 5 seconds and an idling duration of 30 seconds. Adjust according to job requirements.
- When compacting asphalt mixes, select CONT. to fully wet the drum surface, then switch to TIMER. Follow the same procedure for starting the work after a short break.

IMPORTANT

When either of sprinkler switches **A** and **B** is selected, only either of front and rear water tanks will be consumed. Be careful for cock operation.

Liquid spray switch

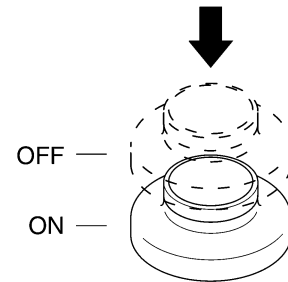

Liquid is sprayed when switch  is pressed. Spraying is shut off if the switch is released. While the liquid is being sprayed, the indicator lamp  on the monitor display lights up.



CAUTION

- Never pull the switch UP.
- Driving the liquid spray pump with the liquid tank empty will damage the pump. Pay attention to the liquid level in the tank.

Parked manual regeneration switch (black)

If the DPF indicator lamp (amber)  flashes, press the switch  in accordance with the manual regeneration procedure to begin DPF regeneration.



CAUTION

Pressing the switch when the DPF indicator lamp (amber) is off will not clean the DPF.

NOTE: Refer to 2.5.1 DPF on page 54 for details on the conditions and points to beware of in manual cleaning.

Engine diagnostic switch

Engine troubleshooting can be conducted using the trouble code selector switch. During normal operation, do not operate switches. Set switch as shown in OFF position during the normal operation. Refer to 2.2.5 Engine troubleshooting page 43 for detail.

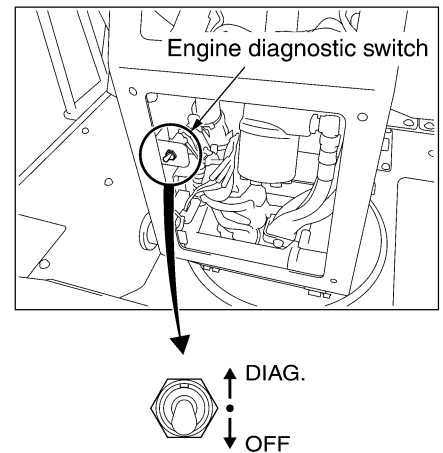

- DIAG. position : Engine diagnostic is activated
- OFF position : Engine diagnostic is shut off

2.1.4 Operating levers and pedals

Forward-Neutral-Reverse (F-N-R) lever with vibrator switch

Moving the F-N-R lever forward or backward makes the machine travel forward or backward respectively. The neutral position brings the machine to a stop. The machine speed increases or decreases in proportion to the lever displacement. The vibrator ON-OFF control is easily made by the F-N-R lever top vibration switch (refer to page 34).

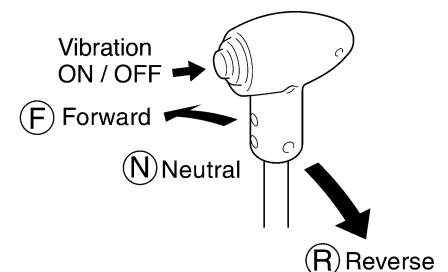

IMPORTANT

- For normal braking, return the F-N-R lever back to neutral.
- In an emergency, depress the brake pedal.

2 OPERATION

Speed shift lever

Selects two machine speed ranges.
Place the lever at the desired position.

Speed shift lever	km/h (mile/h)	
	1st	2nd
Travel speed	0 – 6 (0 – 3.7)	0 – 12 (0 – 7.5)

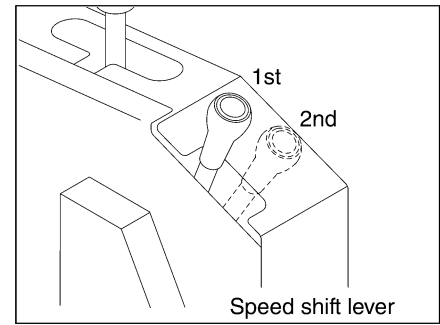

Brake pedal

Use it in emergencies. Carry out inspections in accordance with “3.3 Periodical Maintenance Points” (refer to page 84) after each use.
In an emergency, push down on the pedal to the full extent, and the machine will come to a sudden stop.

IMPORTANT

Do not use the pedal wherever practicable except for an emergency. If used during the compacting operation of asphalt pavement, this can cause damage to its surface.

NOTE: Depressing the brake pedal brings the F-N-R lever into neutral (N) .

2.1.5 Unloader valve

The unloader valve disengages the drive, playing a role like a clutch. Use this valve for towing the machine when the engine is disabled or when troubles have developed in the hydraulic drive.

For towing:

Turn the lever clockwise (Unload).

For normal traveling:

Turn the lever counterclockwise (Onload).

⚠ WARNING

- On a slope, chock the wheels and use extreme care when handling the unloader valve and towing the machine.
- Be sure to apply the parking brake when operating the unloader valve.
- Unloading the unloader valve will disengage the engine, so never get in front of or behind the machine.

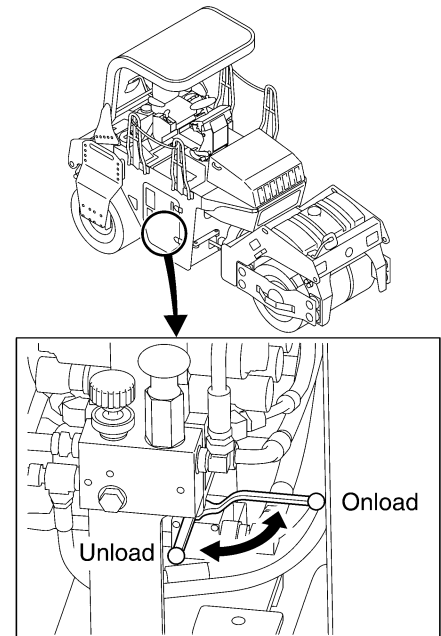

NOTE: For normal travel, be sure to hold the valve in the ONLOAD position.

2.1.6 Fuse box

⚠ WARNING

When changing a fuse, cut the power supply by turning the starter switch to the OFF position.

Fuses protect electrical components and wiring from burning. Change any fuse which has become powder-coated due to deterioration or which has a play between it and fuse holder. To replace fuses, take off the cover.

Be sure to use fuses of correct capacity.

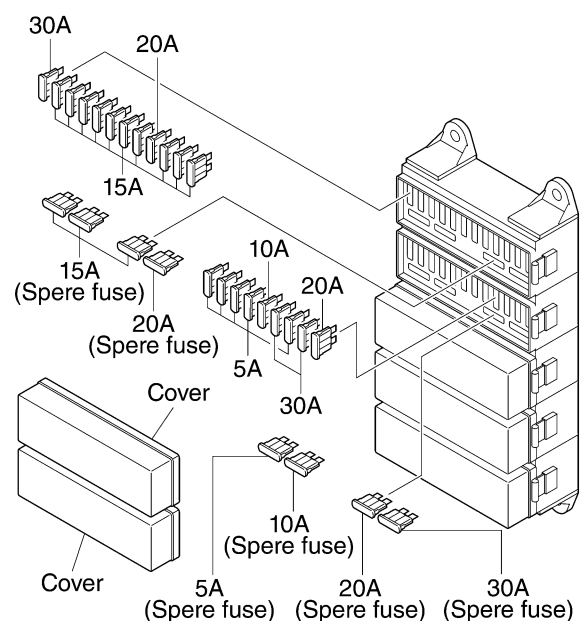

2 OPERATION

2.1.7 Fusible link

⚠ WARNING

Be sure to turn off the electricity (by turning the starter switch OFF) before replacing the fusible link.

As with ordinary fuses, this protects electronic equipment and circuits from burnouts.

If the starter does not turn on when the starter switch is turned to the ON position, there is the possibility of a fusible link burnout caused by problems with the electronic equipment or circuits. Inspect and replace the fusible link after inspecting the electronic equipment and circuits.

Be sure to replace the fusible link with one of the same capacity.

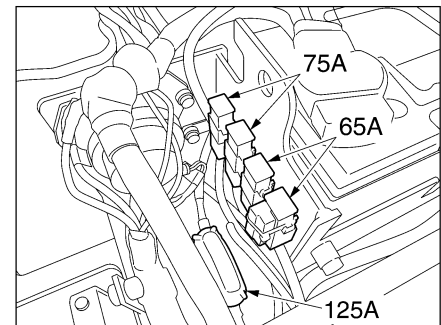
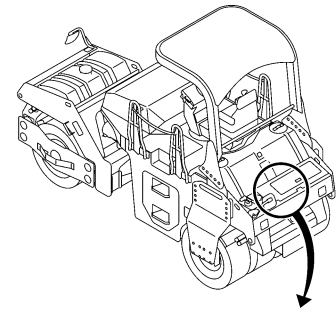

2.1.8 Accessory socket

The accessory socket may be used when the starter switch is turned to the ON position.

Open the cover, and a 12 V DC can be drawn from the socket for powering electronic equipment.

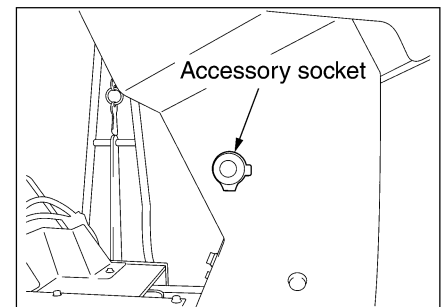

⚠ WARNING

When connecting electronic equipment to the accessory socket, make sure it does not obstruct the raising and lowering of the F-N-R lever.

⚠ CAUTION

- Use electronic equipment that consumes no more than 120 W (12 V, 10 A).
- Keep the cover closed when not in use to prevent foreign matter from getting inside.
- There is a possibility of the battery running flat when the accessory socket is used for a long time to power electronic equipment with the engine turned off or idling.

2.2 Handing and Adjustments

2.2.1 Seat adjustment

Adjust the seat for your best operating position. Move the lever as shown by arrow. With the lever held in that position, slide the seat forward or backward as desired.

When properly adjusted, release the lever.

Adjust your seat position to suit you as follows:

- 1) Pull the lever ① and adjust seat position longitudinally.
- 2) Turn the backrest adjust pull the lever ② for optimum angle.
- 3) Move the suspension lever ③ to select suitable suspension for your body weight.

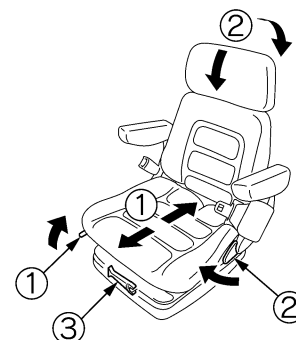

⚠ WARNING

- The seat shall be adjusted before starting any works or when the driver is switched over the other person while the machine is completely stopped.
- Do not adjust the seat while the machine is in motion.
- Some unexpected troubles may be accidentally caused if moving the machine without completely fixing the seat such as while sliding the seat. Before moving the machine, make certain that the seat is completely fixed after making proper adjustments.
- Do not pinch your fingers, hands or legs while adjusting the seat.
- Adjust seat only when one person rides on the machine.
- Adjust seat only when the machine stays on the flat ground.
- Adjust the seat so that your back is in close contact with the back of the seat while seated and when stepping on the brake pedal down to the floor. Adjust the seat so as to be able to certainly step on the brake pedal when twisting your body around to look back in order to move the machine backwards.
- When the operator's platform is rotated 90 degrees, adjust the seat so that the backrest does not protrude beyond the chain.
There is a danger of the seat hitting nearby structures or trees.

IMPORTANT

Be sure to wear the seatbelt during operation.

2 OPERATION

2.2.2 Replacement of scraper

- Remove the scraper from the tire.
- Remove the section ① from the pipe.
- While pulling down the scraper, remove the section ②.

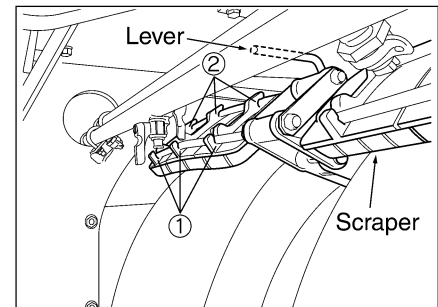

⚠ CAUTION

To ensure long use of the scraper, remove it from the tire unless necessary.
(Roadbed, deadhead, etc.)

2.2.3 Disengaging the brake when towing

⚠ WARNING

On a slope, chock the wheels and prepare for towing before disengaging the brake.

For towing the machine when the engine is disabled or when troubles have developed in the hydraulic system for propulsion, disengage the brake as instructed below:

- 1) Loosen the lock ring of the selector valve and turn the valve knob counterclockwise until it stops.
- 2) Pull up and press the knob of the pump. The parking brake can be released by pressing it about 13 times.
- 3) After the traction is completed, be sure to turn the selector valve knob clockwise until it stops and fix it with the lock ring.

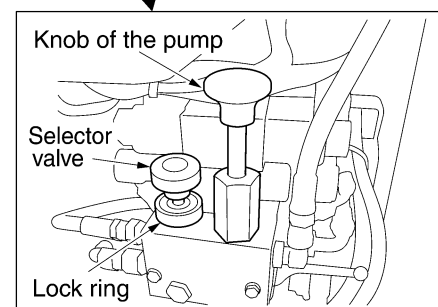
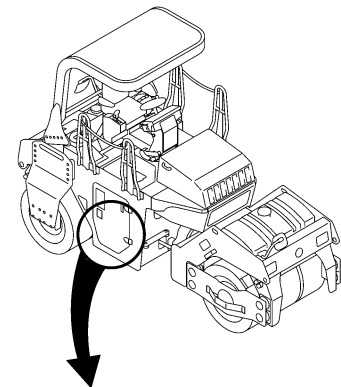

2.2.4 Operator's platform position adjustment

Operator's platform rotates by 60 and 90 degrees, clockwise or counterclock wise.

Set it at the desired angle to allow you to easily see the drum edge during work.

- 1) While depressing the swivel pedal, rotate the operator's platform by pushing or pulling with your other foot.
- 2) As soon as it starts rotating, release the swivel pedal and continue to push the operator's platform at 60 degrees, it will automatically lock into position.
- 3) Continuing the same action while depressing the swivel pedal will allow the operator's platform to lock automatically at 90 degrees.

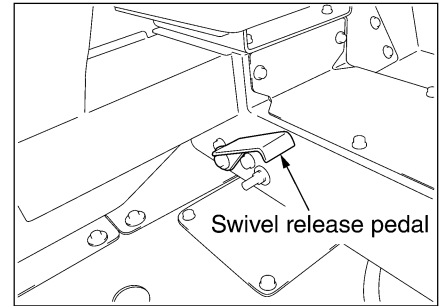

⚠ WARNING

- **Make sure the operator's platform is completely locked in place before continuing to operate the machine. If the operator's platform is not locked in place, it could unexpectedly rotate during operation and cause the operator to lose control of the machine and result in an accident with the potential for injury or death.**
- **When the operator's platform is rotated 90 degrees, adjust the seat so that the backrest does not protrude beyond the chain. There is a danger of the seat hitting nearby structures or trees.**
- **When rotating the operator's platform, be careful not to get a part of your body caught in the space between the seat and the vehicle body.**

⚠ CAUTION

Sit down on the seat during this operation for your safety.

2.2.5 Engine troubleshooting

Engine troubleshooting can be conducted using the engine diagnostic switch.

During normal operation, do not operate switches. Set switch as shown in OFF position during the normal operation.

DIAG. position : Engine diagnostic is activated

OFF position : Engine diagnostic is shut off

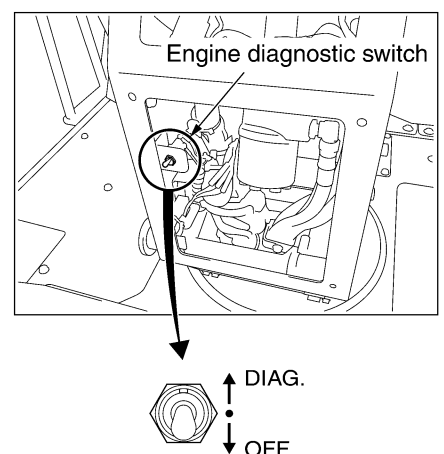

IMPORTANT

When the engine malfunctions or fails, contact your SAKAI Dealer immediately for appropriate inspection, maintenance, or repair.

2 OPERATION

2.3 Operation

⚠ WARNING

- This machine is a one-man roller.
- Operate the machine from the operator's seat.
- Be sure to wear the seatbelt during operation.

2.3.1 Before-starting inspection

- 1) Check that the steering lock bar is in the carrying position.

⚠ WARNING

Make sure that the steering lock bar is connected in the carrying position before putting the machine in motion. Steering is impossible if the bar is in the steering lock position.

The bar is located at the left of the center of the machine.

To unlock the bar:

- ① Remove the R-pin.
- ② Pull out the lock pin.
- ③ Set the bar in the carrying position.

NOTE: Lock the bar by pushing in the lock pin and inserting the spring pin.

- 2) Check that the F-N-R lever is in the neutral position (N).

- 3) Confirm that the parking brake is engaged.

NOTE: When the F-N-R lever is not in the neutral (middle) position, or the parking brake has been released, the interlocking system goes into operation and the engine will not turn on. Be sure to confirm that the F-N-R lever is in the neutral (middle) position, and that the parking brake is engaged before starting the engine.

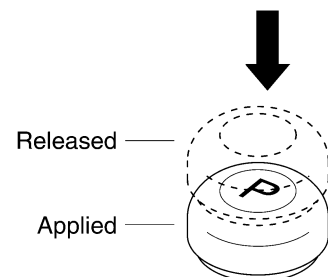
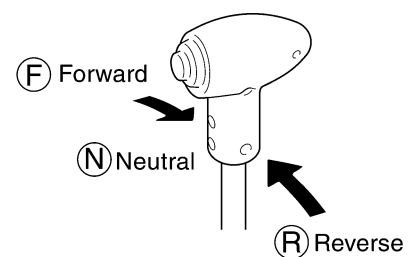
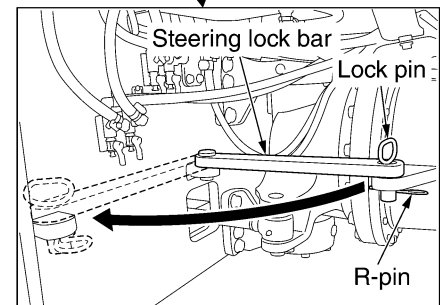
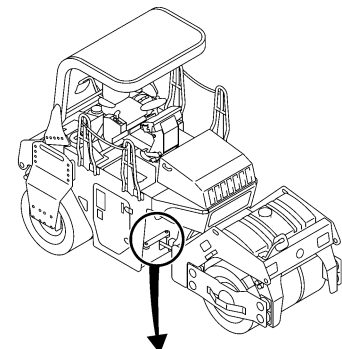

2.3.2 Starting the engine

⚠ WARNING

- Check that there are no people or obstacles around the machine and beep the horn before starting the engine.
- Set the Forward-Neutral-Reverse (F-N-R) lever in the neutral position and press down the parking brake switch before starting the engine. Unless these conditions are met, the engine will not start.

1) Set the engine speed select switch in the IDLE position.

Engine speed	IDLE	MIDDLE	FULL
		1000 min ⁻¹	1900 min ⁻¹

(± 50 min⁻¹)

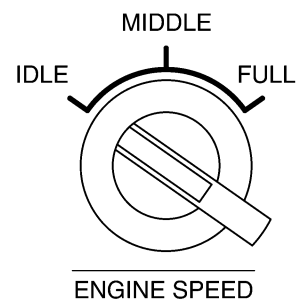

Engine speed selector switch

2) Turn the starter switch to the ON position and check that the warning lamps and parking brake indicator lamp on the monitor display are on.

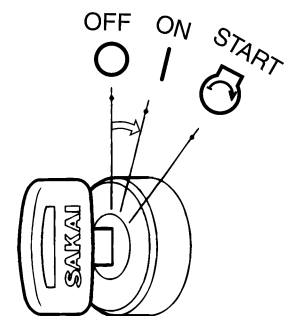
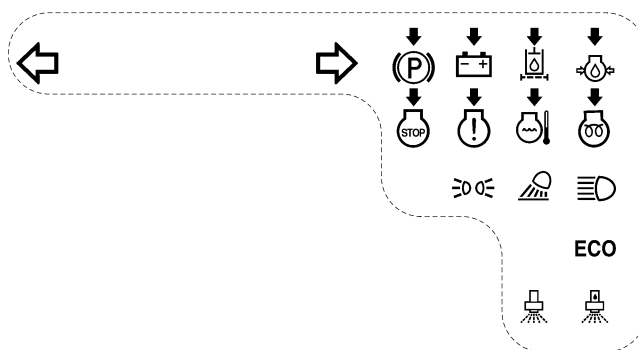

The engine is preheated automatically when it is cold. Hold the key in this position until the  lamp on the monitor display goes out.

Start the engine after the preheating plug indicator lamp goes out.

2 OPERATION

3) Start the engine after the engine check lamp lights up and goes out.



4) Turning the key to the START position makes the engine start. Release the key the moment the engine has started. The key will automatically return to the ON position.

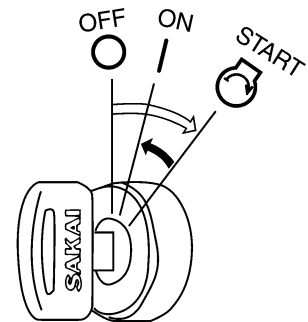

⚠ CAUTION

- Do not allow the starter key to stay in the START position for more than 15 seconds.
- When the engine fails to start, or you want to restart the engine immediately after turning it off, wait around 30 seconds before restarting it.
- If the engine does not start, allow an interval before trying again.
- Check that the warning lamps on the monitor display go off immediately after the engine is started. If any of these warning lamps stay on while the engine is running, shut down the machine, determine the cause and rectify the fault.

2.3.3 After starting the engine

Try not to move to operation immediately after starting but observe the following:

IMPORTANT

Avoid increasing the engine speed abruptly before warming-up run is completed.

- 1) Run the engine at idling for about 5 minutes to warm it up. Warming-up run allows the lubricating oil to reach the vital parts of the engine and hydraulic system, gradually warm the engine, engine oil and hydraulic oil to prepare the machine for driving.
- 2) After the warm-up operation, check that:
 - Temperature gauge Pointer falls near the center zone
 - Fuel gauge Pointer falls between the E and F marks
 - Battery charge lamp Has gone off
 - Engine oil pressure warning lamp Has gone off
 - Engine stop lamp (red) Has gone off
 - Engine warning lamp (amber) Has gone off
 - Engine overheat warning lamp Has gone off
 - DPF indicator lamp (amber) Has gone off
 - DEF tank low-level lamp (amber) Has gone off
 - DEF quality warning lamp (red) Has gone off
 - SCR-system tampering lamp Has gone off
- 3) Check for the color of exhaust gas, listen for unusual sounds and vibration. If abnormal, determine the cause and correct the problem.

WARNING

Keep staying at the driver's seat while starting the engine.

2 OPERATION

2.3.4 Traveling

⚠ WARNING

- When starting, operate the horn after securing the safety around the machine. Clear away obstacles on the road.
- Be sure to wear the seatbelt during operation.
- Use the chain while driving.

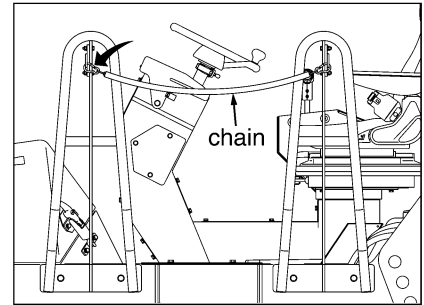

⚠ CAUTION

While travelling, do not turn the starter switch OFF.

- 1) Select MIDDLE or FULL position of Engine speed selector switch.

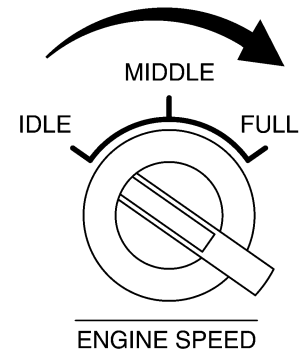

Engine speed selector switch

- 2) Press down parking brake switch button to release the brake. Check that indicator lamp (P) on the monitor display goes off.

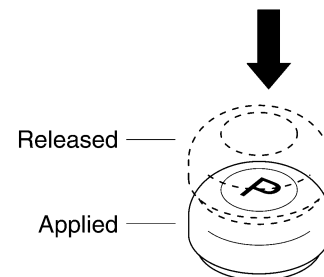

- 3) Move the F-N-R lever in the direction to travel, and the machine will begin traveling.

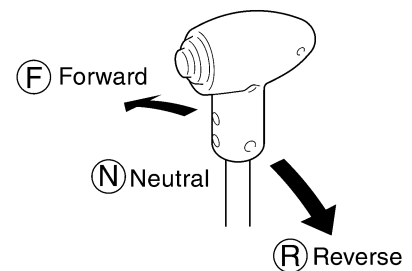

⚠ WARNING

- Pay extreme attention to the area behind the machine when backing, since the space just behind it tends to be a blind spot.
- Pay careful attention to your surroundings and maintain control of the machine when changing switch positions. Whenever possible, stop the machine to change switch settings before continuing operation.

⚠ CAUTION

Avoid abrupt operation of the F-N-R lever.

NOTE: The travel speed can be controlled by the engine speed select switch, speed shift lever and F-N-R lever.

2 OPERATION

2.3.5 Stopping / Parking

⚠ WARNING

- Avoid abrupt braking. Leave enough space for braking safety.
- Avoid parking on a grade.
- If necessary to park on a grade, block the wheel to prevent unexpected moving down the grade.

- 1) Bring the F-N-R lever to the neutral position (N), and the machine will come to a halt.

⚠ WARNING

Frequent use of the brake pedal may damage the motor.

⚠ CAUTION

For normal braking, move the F-N-R lever back to the neutral position. In an emergency, depress the brake pedal. The F-N-R lever is brought back to the neutral position.

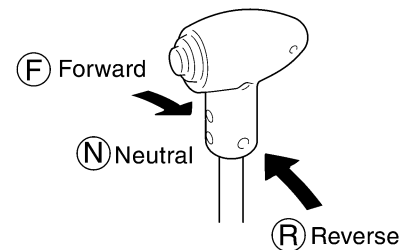

- 2) Press the parking switch button securely, and check that indicator lamp (P) illuminates.

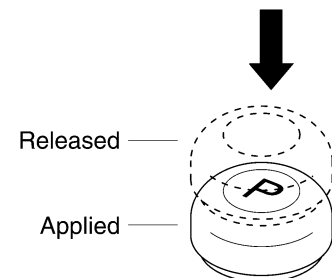

2.3.6 Stopping the engine

- 1) Set the Engine speed select switch at the IDLE position, wait for about 5 minutes with the engine idling to gradually cool the engine.

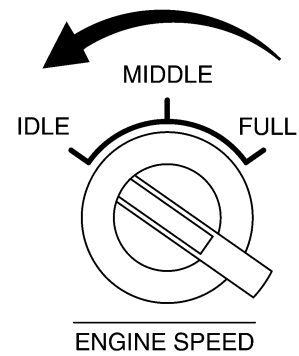

Engine speed selector switch

IMPORTANT

- Do not bring a hot engine to a sudden stop except for an emergency. This will shorten the life of its component parts.
- Do not also allow an overheated engine to come to a sudden stop, but run it at middle idling speed for gradual cooling down.

- 2) Turn the starter key to the OFF position to stop the engine.

CAUTION

While travelling, do not turn the starter switch OFF.

IMPORTANT

The DEF Pump will continue running for several dozen seconds to cool the DEF Injector after turning off the starter switch. This is not a malfunction.

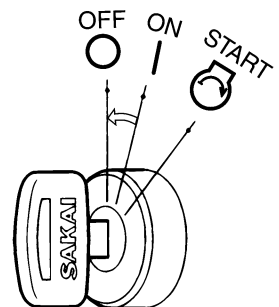

- 3) Pull off the starter switch key.

WARNING

- When dismounting from the machine, apply the parking brake by actuating the parking brake switch. If necessary to park on a slope, chock the drums to prevent unexpected moving down the slope.
- Remove the starter switch key.

2.3.7 Check after stopping the engine

- 1) Perform the walk around checks for oil and water leakage, abnormal signs around the drums.
- 2) Fill the fuel tank.
- 3) Remove waste paper if any from the engine compartment, as this will pose a possible fire hazard.
- 4) Scrape mud or other materials from and around the drums.

2.4 Vibratory Operation

- 1) Turn the Engine speed select switch clockwise to set the engine RPM to MIDDLE or FULL.

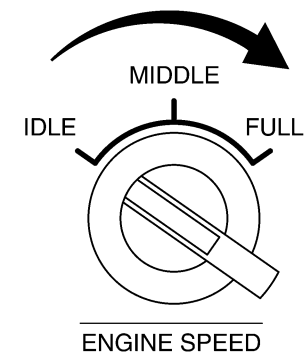

Engine speed selector switch

- 2) Select  or AUTO position of Vibration mode selector switch.

 position : Vibration can be controlled by the vibration switch on the F-N-R lever

AUTO position : Vibration is automatically engaged when the F-N-R lever is moved into the forward or reverse positions

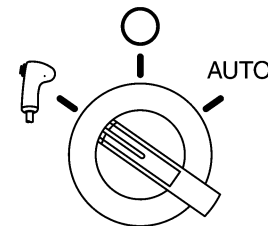

NOTE: Vibratory compaction is not possible when the the engine speed selector switch is in the IDLE position.

3) Switching from 1 to 4 causes vibration at higher amplitude.

When operating at vibration 2 to 4, changeover the vibration switch A first while the vibration switch B is kept at 2 to 4.

Vibration 1 operates even in stop state if the engine speed is MIDDLE or FULL position, but vibration 2 to 4 operates only while moving forward or backward.

When the F-N-R lever is placed in the neutral position during rolling compaction work at vibration 2 to 4, return is made to the amplitude of vibration 1.

Tilting the lever again resets the amplitude to the selected one of 2 to 4.

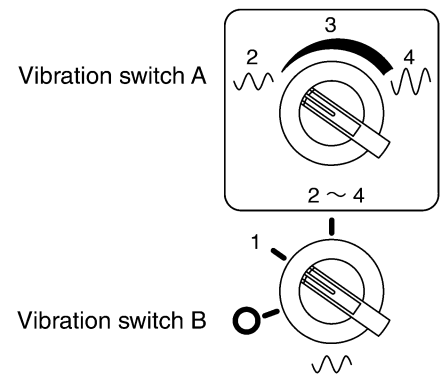

IMPORTANT

- **Avoid long-time vibration at vibration 1 while the machine stops.**
- **If traveling becomes impossible due to mud, etc. during vibration rolling compaction, immediately stop vibration.**
- **Because of the characteristic of the amplitude selector system, switching to lower amplitude such as from 4 to 3 or from 3 to 2 cannot be sensed, and in order to switch to lower amplitude, therefore, turn the amplitude selector switch to “OFF” once, and then select the amplitude again.**

2.5 Operating the After Treatment System

2.5.1 DPF

About the DPF (diesel particulate filter)

The DPF is a filter, which collects PM (particulate matter) contained in the exhaust gas. To remove the PM collected in the DPF, it is burned (regenerated) automatically or manually. Be sure to observe the following to maintain the performance of the DPF.

- Always use fuel and lubricants designated or recommended by our company. (refer to page 109)
- Do not modify the DPF muffler or exhaust pipe in any way. It may hinder its proper performance or lead to breakdowns.
- Do not use DPFs that have been dropped. The DPF consists of a ceramic catalyst installed inside the muffler. A strong impact may damage the DPF.

Regeneration the DPF

When the amount of PM accumulated in the DPF reaches a specified level, the PM is automatically burned (regenerated). When the PM cannot be removed automatically. It is burned manually.

WARNING

- **Do not carry out regenerating in enclosed spaces with poor ventilation, such as inside a garage or a room. There is the danger of carbon monoxide poisoning.**
- **Check to make sure there are no inflammables near the mouth of the exhaust pipe to prevent fires.**
- **Do not touch or let people go near the exhaust pipe or muffler, which will be hot during regenerating, and for a while after regenerating.**
- **Carrying out regenerating on painted roads may cause the paint to discolor.**
- **Carrying out regenerating in front of hedges may cause them to wither.**

Automatic regeneration

When the coolant temperature and exhaust temperature are at a specified level when the DPF indicator lamp turns on, the PM accumulated in the DPF will automatically be burned (automatic regeneration). The machine can be driven as usual during automatic regeneration. Moreover, if even one of the conditions strays from the specified level during automatic regeneration, it will stop. The DPF indicator lamp will turn off when automatic regeneration has been completed.

Manual regeneration

The PM accumulated in the DPF can be burned (manual regeneration) by following the procedures outlined below, while the DPF indicator lamp is flashing. Failure to carry out manual regeneration, while the DPF indicator lamp is flashing, may lead to breakdowns.

Follow the procedures below to carry out manual regeneration.

- 1) Move the machine to safe location.
- 2) Shift F-N-R lever into neutral.
- 3) Push on parking brake switch.
- 4) Keep engine rpm at idle.
- 5) Push on parked manual regeneration switch.

The DPF indicator lamp will flash then turn on when the parked manual regeneration switch is pushed. The engine will automatically rev up and manual regeneration will begin. Manual regeneration will finish when the engine returns to idling and the DPF indicator lamp turns off.

⚠ CAUTION

- **The exhaust gas temperature will rise during regeneration, so beware of burns, fires, etc.**
- **The after treatment must never be modified. The machine will not be able to function properly, and it will not satisfy exhaust gas emissions standards.**
- **Do not turn the engine off immediately after regeneration.**
Set the engine speed selector switch in the idling position, and let the engine idle to gradually cool it for around 5 minutes.
- **Stopping the engine suddenly without letting it cool may shorten the life span of engine parts.**
- **Continuing to use the machine without carrying out regeneration when the parked manual regeneration lamp / regeneration lamp is flashing may, in the worst case scenario, result in a limit being placed on the engine output.**
Promptly carry out parked manual regeneration.
- **Parked manual regeneration can be carried out any time, but limit it to once daily except when the parked manual regeneration lamp / regeneration lamp flashes.**
- **Operating the parking brake switch, engine speed selector switch or F-N-R lever during parked manual regeneration will automatically stop regeneration. Restart parked manual regeneration in accordance with the prescribed procedures.**

- 6) Carrying out regeneration on cold days.

Be sure to let the engine warm up adequately on cold days before carrying out regeneration.

As a rough guide, let the engine warm up until the thermometer indicates the position shown in the illustration on the right.

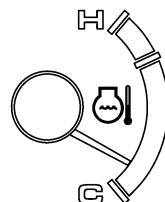

Temperature gauge

Regeneration "RGN" of DPF for Operator / Engine Diagnosis

Level (Stage)	DPF Gauge DPF LEVEL 	RGN lamp	Parked Manual RGN Switch	Engine warning lamp	Warning Buzzer	Auto RGN	Parked Manual RGN	Limit of Engine Output	Operations	
0 (No RGN Needed)	1 ~ 9	OFF		OFF	OFF	No Need	No Need	NO	Normal machine operation is available. RGN is not required.	
1 (Auto RGN)	10 (Max)	Solid lighting		OFF	OFF	Applicable	No Need	NO	Normal machine operation is available. When RGN lamp goes on during Auto RGN, keep engine RPM at Max for 30 minutes to perform best RGN.	
2 (Requesting Parked RGN)		Blinking		OFF	Intermittent Sound	Applicable	Applicable	NO	Perform a Parked RGN as early as possible by following instructions, "Procedure of Parked RGN" below, when the RGN lamp starts blinking.	
3 (Parked RGN Urgent Request)		Blinking	Start Parked RGN by pushing the switch. RGN lamp blinking changes to solid.	Solid lighting	Intermittent Sound	Not Applicable	Applicable	YES	URGENT: If Engine Warning lamp turns on while the RGN lamp is blinking a Parked RGN must be performed urgently to prevent possible costly repairs. If RGN lamp doesn't go off after Parked RGN, access the engine error codes at the display and contact your Sakai dealer or company Techs.	
General Cautions for Safe RGN	<ol style="list-style-type: none"> 1. Don't perform Parked RGN in closed unventilated space. Poisoning by carbon monoxide gas can occur. 2. Don't touch and/or get close to "HOT" DPF and exhaust pipes during and after RGN to avoid burns. 3. Hot exhaust gas can ignite combustible material during RGN. Insure hot exhaust is dissipated away from combustible materials. 4. Exhaust smoke may be white during part of RGN. 5. Idle for 5 minutes after RGN. Do not shut down immediately after RGN. 						<ol style="list-style-type: none"> 1. Move the machine to safe location. 2. Shift F-N-R lever into neutral. 3. Push on parking switch. 4. Keep engine rpm at idle. 5. Push on Parked Manual RGN switch. With a start of RGN, RGN lamp stops blinking and goes on. 6. The engine will rev up automatically, and then return to idle after about 30 minutes, and then lamps turn off when RGN is completed. 7. Idle for 5 minutes after Parked RGN. Do not shut down immediately after Parked RGN. 		Procedure of Parked RGN	
Daily Check of Engine Oil Level and Oil Change	<ol style="list-style-type: none"> 1. If engine oil level exceeds the upper level, change oil as soon as possible. Engine may be damaged by oil mixed with post-injected fuel during RGN. 2. Change oil when RGN interval gets shorter than 5 hours. 3. Be sure to use engine oil with grade of JASO DH-2 or API CJ-4. 									

2.5.2 DEF SCR system

About the DEF SCR (Selective Catalytic Reduction) system

The DEF SCR system breaks down toxic nitrogen oxides (NOx) contained in the exhaust gas into harmless nitrogen and water. DEF is sprayed into the exhaust gas, and the ammonia generated by the urea reacts with the nitrogen oxides breaking them down into nitrogen and water.

⚠ CAUTION

- **Keep the DEF tank topped up by refilling it at the right time.**
- **Always use the DEF designated by our company.**
- **The exhaust gas temperature will rise during regeneration, so beware of burns, fires, etc.**
- **The aftertreatment must never be modified. The machine will not be able to function properly, and it will not satisfy exhaust gas emissions standards.**
- **Do not turn the engine off immediately after regeneration.**
Set the Engine speed selector switch in the idling position, and let the engine idle to gradually cool it for around 5 minutes.
- **Stopping the engine suddenly without letting it cool may shorten the life span of engine parts.**
- **Continuing to use the machine without carrying out regeneration when the parked manual regeneration lamp / regeneration lamp is flashing may, in the worst case scenario, result in a limit being placed on the engine output.**
Promptly carry out parked manual regeneration.
- **Parked manual regeneration can be carried out any time, but limit it to once daily except when the parked manual regeneration lamp / regeneration lamp flashes.**
- **Operating the parking brake switch, Engine speed selector switch or F-N-R lever during parked manual regeneration will automatically stop regeneration.**
Restart parked manual regeneration in accordance with the prescribed procedures.

• When the DEF level is low

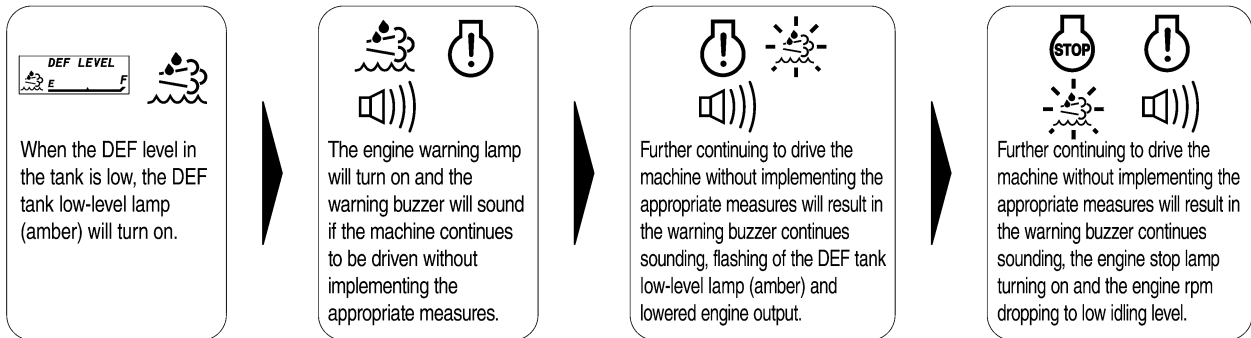

Countermeasure: When the above warning is displayed, fill the tank immediately with DEF designated by our company. If the warning lamp does not turn off even after filling the tank with DEF, stop the engine, make sure the warning lamp turns off, then turn the starter switch from the OFF position to the ON position twice before restarting the engine.

• When there is an abnormality in the DEF quality

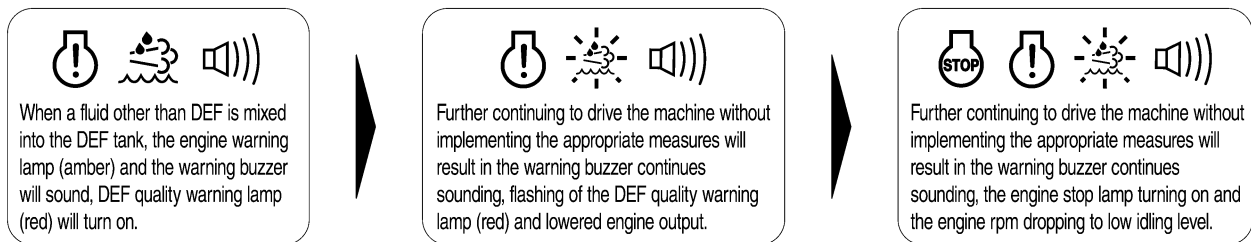

Countermeasure: When the above warning is displayed, completely drain the fluid from the DEF tank, and change it to the DEF designated by our company. If the warning does not turn off even after changing the DEF, stop the engine, turn the starter switch from the OFF position to the ON position twice, then restart the engine.

• Abnormality in the DEF SCR system

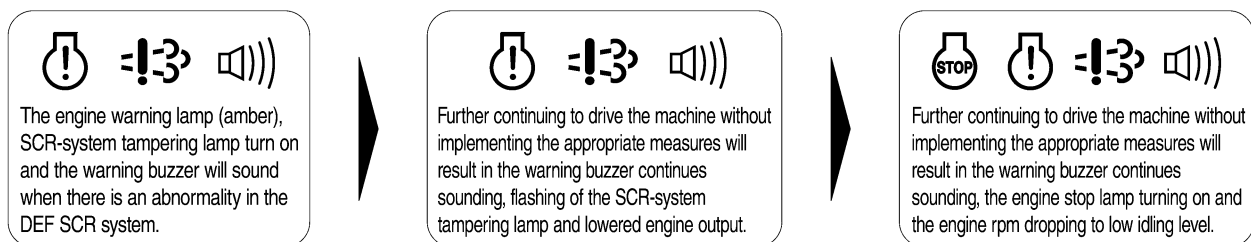

Countermeasure: When the above warning is displayed, contact one of our sales offices or a factory designated by our company for advice.

⚠ WARNING

- DEF on the skin may cause inflammation in some people, so contaminated clothes, shoes, etc., should be taken off and washed in cold or warm water. If there are any changes in appearance or pain, promptly seek medical help.
- If the DEF is accidentally swallowed, rinse out your mouth well with water, and promptly seek medical help.
- If the DEF gets in your eyes, rinse it out immediately in clean water for several minutes, then promptly seek medical help.
- Wear protective glasses when there is a danger of the DEF splattering. Wear rubber gloves if work requires you to come into contact with the DEF.
- Do not put anything other than DEF into the DEF tank. Diesel, gasoline, etc., in particular may cause fires. Moreover, putting additives in the tank may lead to generation of toxic gases.
- Opening the DEF tank cap may release toxic ammonia gas. When opening the cap or filling the tank, keep your face away from the filler port.
- If the DEF is spilled, promptly wipe it clean and wash with water. Neglecting to do so may lead to toxic gases or corrosive substances being given off.

⚠ CAUTION

- Put AUS32 or ISO (International Organization for Standardization) ISO22241-1 certified DEF in the DEF tank.
Using anything else may cause breakdowns in the DEF SCR system.
- Never modify the DEF SCR system.
- The machine will not be able to function properly, and it will not satisfy exhaust gas emissions standards. It may also damage the machine.
- The machine will continue running for several minutes after the engine starter switch has been turned off, but this is to pump the DEF left in the pipes, injector, and supply pump back into the DEF tank, and it is not abnormal.
Moreover, do not pull out the battery cord while the system is still running.
- Keep the DEF tank topped up by refilling it at the right time.
- If the engine has not been turned on for one year or more, replace the DEF before starting it. Starting the engine without doing so may cause the SCR system to break down.
- Check the DEF SCR system to make sure there are no abnormalities after starting the engine.
If there is something wrong with the DEF SCR system, stop the engine and restart it.

2.6 Sprinkler / Changeover Valve

- 1) Before sprinkling, check for the water level in the sprinkler tank with the sight level gauge.
Add water as necessary.

CAUTION

**Do not fill the sprinkler tank quickly.
It may damage the tank.**

IMPORTANT

Use clean water wherever practicable.

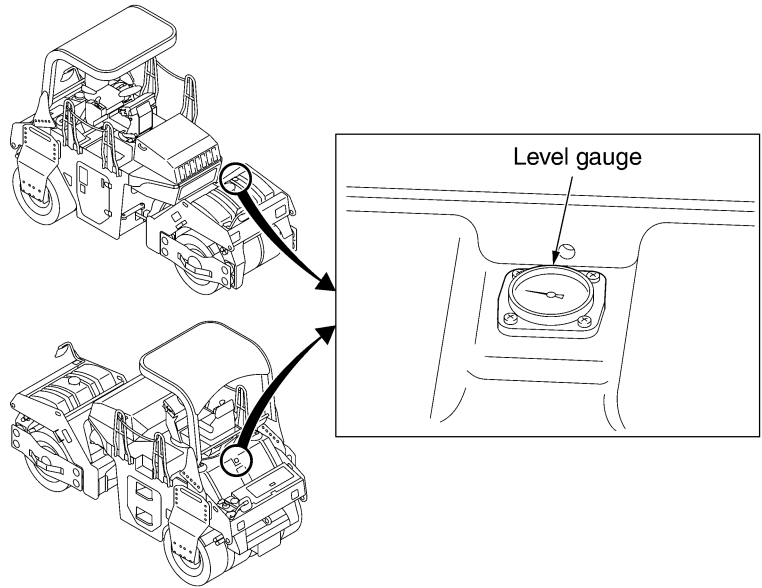

- 2) Push sprinkler switches (A)(B) (PUMP A and PUMP B) to activate the sprinkler pump for sprinkling.

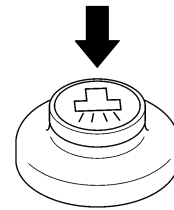

Sprinkler switch (A)(B)

- 3) Sprinkler selector switch (C) selects sprinkler modes; continuous sprinkling mode and intermittent sprinkling mode.

CONT. : Continuous sprinkling

AUTO : Spraying is done interlocking with forward / backward movement.

TIMER : Intermittent (timer) sprinkling

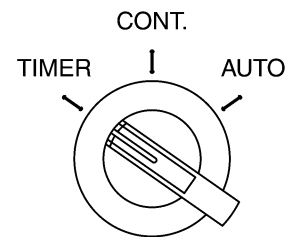

Sprinkler selector switch (C)

For intermittent spray, set the spray time in the following manner:

Spray time is adjustable between 0 – 20 seconds with SPRAY Dial (D) and so is pause time between 0 – 60 seconds with PAUSE Dial (E) respectively as desired.

Adjust it according to the job requirement.

The sprinkler indicator lamp stays bright as long as the sprinkling is being performed.

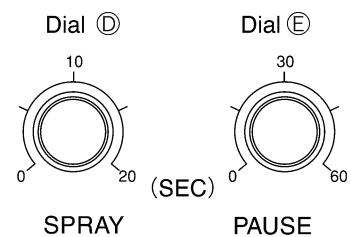

- The table below serves as a guide for sprinkling and idling durations.

Machine speed km/h (mile/h)	Sprinkling duration (seconds)	Idling duration (seconds)
2 (1.2)	7 – 8	35 – 40
3 (1.9)	4 – 5	30 – 35
4 (2.5)	3 – 4	25 – 30
5 (3.1)	2.5 – 3.5	20 – 25

- For normal operation (3 km/h, 1.9 mile/h), use the sprinkler with a sprinkling duration of 5 seconds and an idling duration of 30 seconds. Adjust according to job requirements.

⚠ CAUTION

- **Pay attention to level of water, because turning the pump with empty tank results in trouble.**
- **Sprinkling may stop if either of the front or rear sprinkler tanks becomes empty. Check for the water level in the sprinkler tank.**
- **To avoid freezing, fully drain the sprinkler tank, pipes and filter in cold weather (See “To drain water” on page 63).**

IMPORTANT

When compacting asphalt mixes, select to fully wet the tire surface, then switch to TIMER. Follow the same procedure for starting the work after a short break.

2 OPERATION

Changeover valve

Water in the front and rear sprinkler tanks is simultaneously supplied to the pump. If traveling is done on an uphill slope when the water level of the sprinkler tanks is high, water may move from the higher tank to the lower tank resulting in overflowing from the lower tank. When you park on an uphill slope, shut a valve indicated by the circle.

⚠ CAUTION

When the valve is closed, only one tank at the back of the machine is used. When the slope changes to a flat road, open the valve quickly. When the valve is opened, the water levels in the tanks in front and behind are flush with each other.

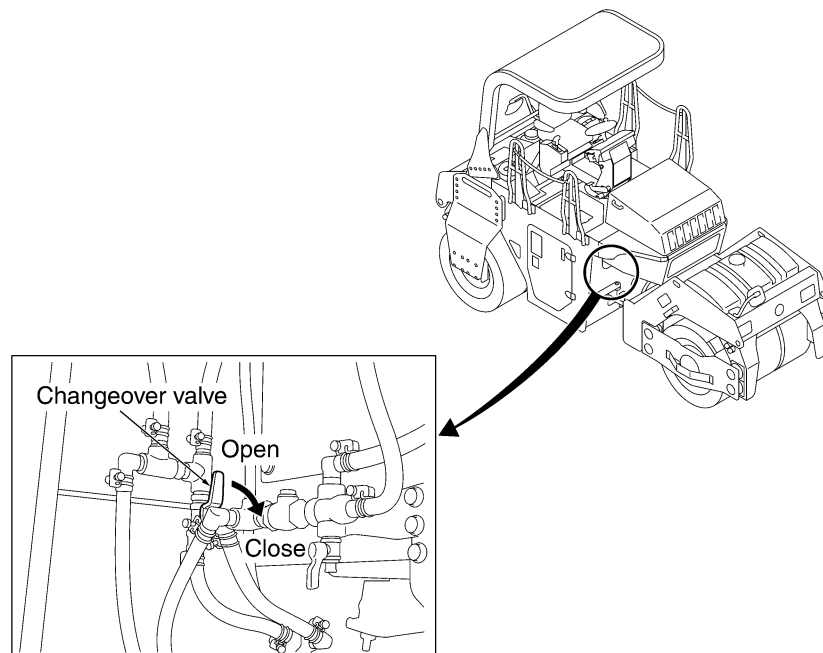

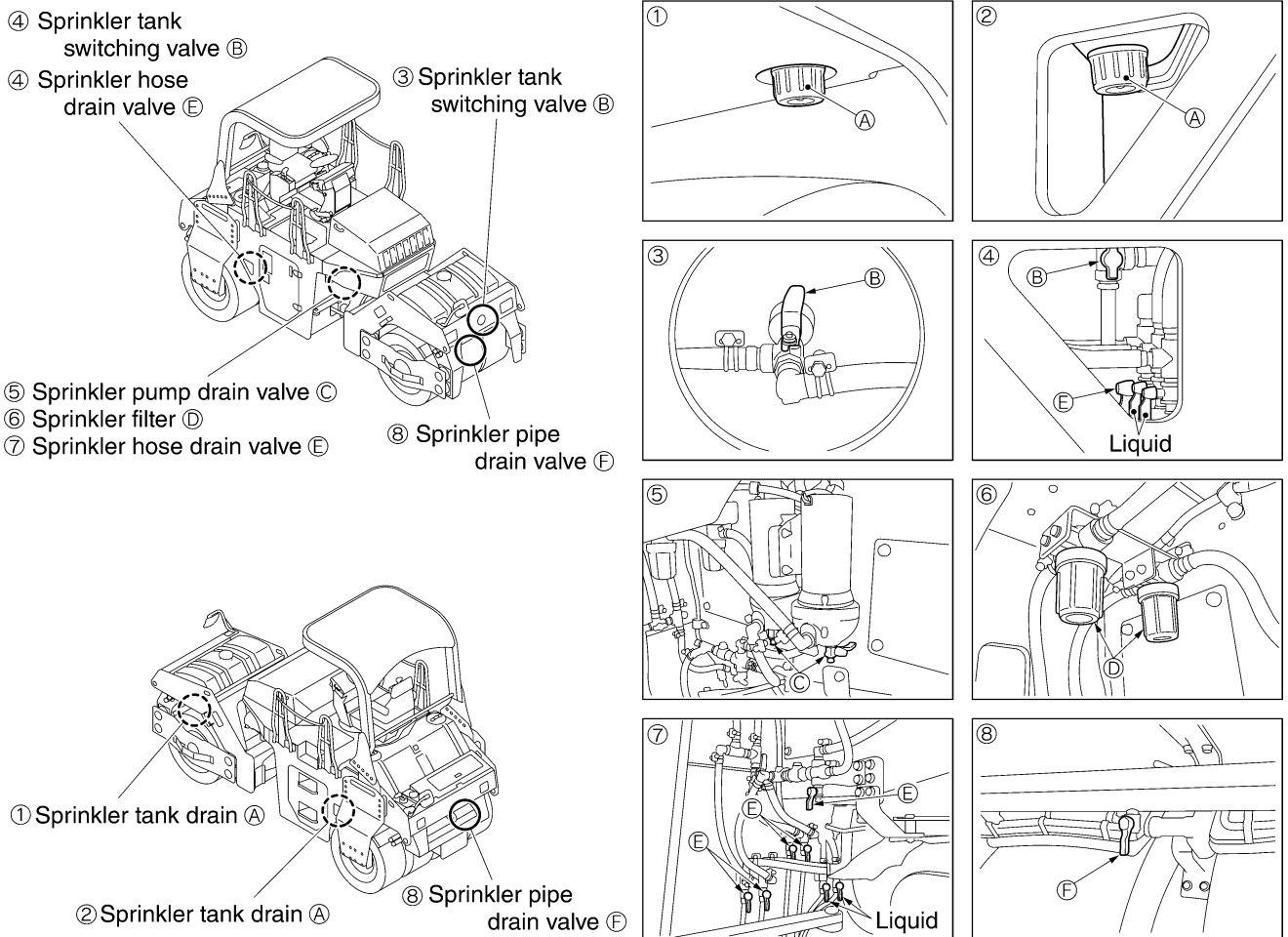

To drain water:

- 1) Turn sprinkler tank drain cap (A) counterclockwise and completely drain the tank.
- 2) Fully open sprinkler tank switching valve (B), and then open sprinkler pump drain valve (C), sprinkler hose drain valve (E), to remove water completely.
- 3) Drain the front and rear sprinkler pipes by opening drain valve (F).
Take off the bowl from sprinkler filters then throw away water in the bowl then put the bowl back on the sprinkler filters (D).
- 4) Idle the sprinkler pump, while sprinkler pump drain valve (C) is open, for about 30 seconds after confirmation of complete removal of water from the sprinkler filter in order to remove water from the pump completely.
- 5) Also drain the hoses, pump and sprinkler nozzles.

⚠ CAUTION

- To avoid freezing, fully drain the water tank, pipes and filters in cold weather.
- Pay attention to the water level because turning the pump with an empty water tank will damage the pumps.
- When water is discharged from the water tank by removing the drum cap, without removing the water tank cap, it may cause the water tank to deform.

2 OPERATION

2.7 Liquid Sprayer

- 1) Before spraying, check for the liquid level in the tank with the sight gauge. Add liquid as necessary.

⚠ CAUTION

Driving the liquid spray pump with the liquid tank empty will damage the pump. Pay attention to the liquid level in the tank.

- 2) Fully open liquid spray valve (A) by turning its lever in the closing direction.

⚠ CAUTION

If an attempt is made to leave the machine unused for a long period, fully close liquid spray stop valve (A) by turning its lever in the closing direction.

- 3) The liquid to prevent sticking to tires is sprayed by pressing the liquid spray switch and the spraying is automatically stopped when the switch is released.
- 4) The liquid spraying rate is adjusted with the spraying rate adjusting valve (A). Adjust the flow rate by turning the valve gradually in the "CLOSE" direction.

Adjusting spread of nozzle

When the liquid is sprayed to the tire, the spread of the nozzle should be adjusted so that the liquid will be applied within the tire width. Use a mirror to make adjustments, or get someone else to check it.

The spread of the nozzle is adjusted with the round handle of the valve (A) located at the liquid valve end of the front/rear tires.

Counterclockwise turning of round handle To increase the spread of the nozzle (spraying rate is increased)

Clockwise turning of round handle To decrease the spread of the nozzle (spraying rate is decreased)

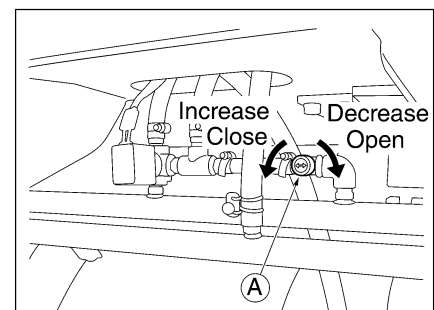
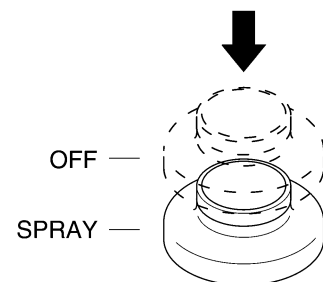
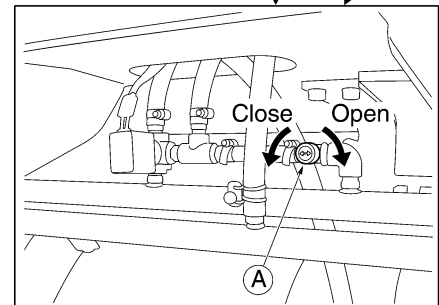
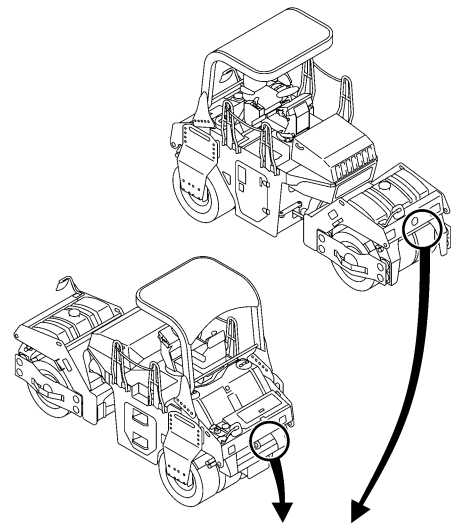

- 5) In case when such liquid as cutting oil that may be frozen when it is cold, open the valve ② at the left end of the machine front / rear as well as the valve ③ above the liquid tank after the work is completed, and press the liquid spray switch to drive the pump, and then drain the liquid completely. In addition, the same procedure should be done for long-term storage. Close both cocks when using it again.

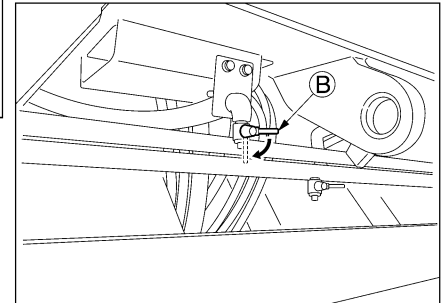
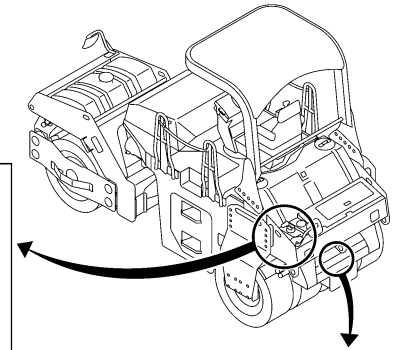
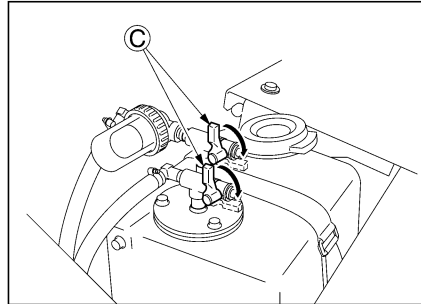

⚠ CAUTION

- Diesel oil, kerosene, etc. must not be sprayed to tires because they will cause tire swelling / deformation and asphalt discoloring.
- Pump driving when the liquid tank is empty is allowed only for a short time. If the pump is driven for a long time when empty, failure may be caused. Attention should be paid to the liquid level.

2.8 Precautions for Work

2.8.1 Compaction operation

■ Rolling compaction of asphalt

- For asphalt compaction, use amplitude 1 or 2.

■ Change the direction of travel gently

- When changing the direction of travel during asphalt mix compaction, slowly shift the F-N-R lever.

■ Drive at a speed appropriate for the road surface conditions

- Drive slowly on uneven surfaces.

2.8.2 When going downhill

■ Use the F-N-R lever

- Run slowly by the operation of the F-N-R lever even if the travel distance is short.

■ Use the engine brake

- Go downhill by applying the engine brake along with the F-N-R lever operation.

⚠ WARNING

When going uphill, run at low speed. Do not attempt to shift speeds during travelling. The machine can slip down the slope.

2.8.3 On a slope

■ Working on a sidehill

- Work in an uphill / downhill direction, and avoid working on sidehill with the machine inclining sideways.

2.9 Applicable Jobs

The machines do a variety of jobs as listed below.

1) This machine is mainly used for:

- Static compacting work
- Vibratory compacting work

2) The machines do a variety of jobs as listed below.

Work

- Asphalt road paving
- Dust removal treatment for road
- Road improvement
- Embankment construction
- Dam construction
- Construction of forestry and farm roads
- Foundation building
- Construction of sidewalk, shoulder and gutter foundation

Material to be compacted

- Asphalt pavement
- Crusher run
- Cement concrete
- Sands
- Soils
- Slag
- Soft rock

Layers to be compacted

- Surface course, Binder course
- Base course
- Subgrade
- Embankment
- Shoulder
- Sidewalk

2.10 After Operation

Check for the coolant temperature, engine oil pressure, fuel level and DEF level.

Follow the procedures below to prevent the machine from falling into an unworkable condition the following morning caused by muds and other extraneous matter on the drum, or frozen drums:

- 1) Remove muds and water from the machine. Muds can get into the seals together with water drops on the hydraulic cylinder piston rod. Damaged seals will result.
- 2) Park the machine on a hard and dry surface. If such a place is not available, cover the ground with hard plates.
- 3) Low temperature will cause a significant reduction of battery efficiency. Cover batteries or take them off from the machine and store in a warm place for the following day's operation.
- 4) To prevent freezing, drain water from the sprinkler system (refer to page 63).

IMPORTANT

- **Drain water completely from the sprinkler system, as remaining water can cause damage to the system.**
- **Do not wash clean with high pressure water around the instrument panel or reverse side of the dash board. This can cause instrument failures.**

2.11 Loading and Unloading

⚠ WARNING

- **Use sturdy ramps with proper width, length and thickness which allow safe loading and unloading.**
- **If the ramps deflect considerably under load, apply wooden blocks to reinforce them.**
- **Loading should be conducted on a level and hard ground. Leave a sufficient distance between the machine and the shoulder.**
- **To prevent slippage on the ramps, keep the drums free from mud, oils, etc. The ramps must also be free of grease, oil and ice.**
- **Do not steer the machine on the ramps. If the machine is facing in the wrong direction, allow it to dismount from the ramps and correct the direction.**

For loading and unloading, use ramps or a proper loading stand.

2.11.1 Use of a truck or trailer equipped with a winch

⚠ WARNING

Placing the unloader in UNLOAD position disrupts the power for traction. Do not enter the areas ahead of and behind the machine. It is very dangerous.

1) Engage the truck or trailer brake and chock its wheels. Fix the ramps so that the machine and truck or trailer are completely aligned.

☆ The angle between the ramps and ground must be less than 15 degrees.

☆ Leave a proper space between the ramps according to the width of the roller drum.

2) Decide the correct direction of run and make the machine run forward to the ramps.

3) Draw the wire rope from the truck or trailer winch and put its hook on the hooking point ① or ② of the roller.

4) Place the unloader valve located at the operator's station to the UNLOAD position (See "Unloader valve" on page 39).

5) With the engine running at idle, perform loading by means of the truck or trailer winch.

6) When the loading is completed, set the unloader valve back in the ONLOAD position.

7) Locate the machine correctly on the truck or trailer.

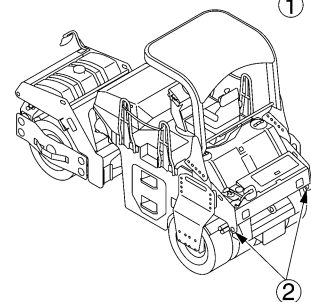
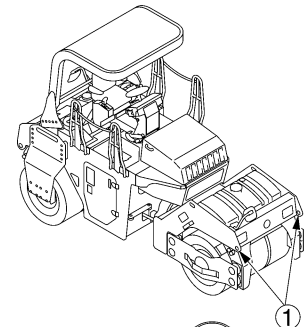
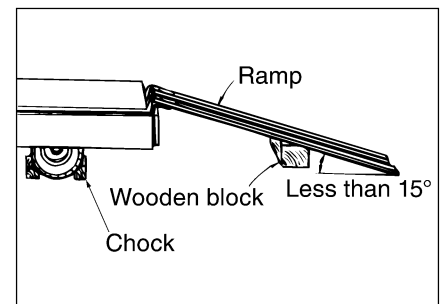

2 OPERATION

2.11.2 Self-propelling

1) Engage the truck or trailer brake and chock its wheels. Fix the ramps so that the machine and truck or trailer are completely aligned.

☆ The angle between the ramps and ground must be less than 15 degrees.

☆ Leave a proper space between the ramps according to the width of the roller drum.

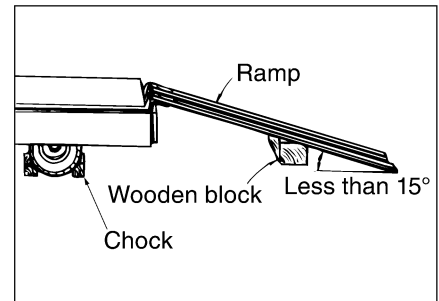

2) Decide the correct direction of run and conduct loading or unloading at low speed.

For loading, run forward at low speed.

For unloading, run backward at low speed.

3) Locate the machine correctly on the truck or trailer.

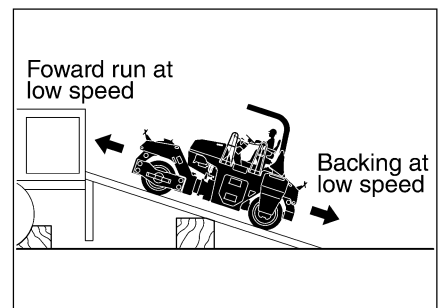

2.12 After Loading the Machine

When the machine has been located properly on the truck or trailer, tie it down as follows:

- 1) Press the parking switch button to apply the parking brake. Place wooden blocks under the drums to prevent movement.
- 2) Fix the machine with ropes tied at the front and rear towing hook holes. Particularly, pay attention to sidewise skidding.

2.13 Transportation

⚠ WARNING

To decide the transporting route, check the width of the road, height and weight (including the roller) of the truck or trailer. Obey relevant regulations.

For transportation, obey traffic regulations.

2.14 Operation in Cold Weather

In cold weather, take the following measures to prevent troubles such as starting difficulty and coolant freeze-up.

⚠ CAUTION

- When using the machine in temperatures below -15°C , it will be necessary to add a heater kit to the engine oil separator. Contact a nearby SAKAI Service Center.
- Condensation inside the exhaust pipe may be discharged when the engine is started. It is not urea water.

2.14.1 Fuel oil and grease

Use fuel and oil with low viscosity. See "Rating" on page 109.

2.14.2 Coolant

⚠ WARNING

Do not bring an open flame to the antifreeze or do not smoke when handling it. It is inflammable.

⚠ CAUTION

- Never use methanol-, ethanol- and propanol-base antifreeze.
- Use ethylene glycol-base antifreeze.

For the cooling water, mix the antifreeze in water.

Use softened water as the water to be mixed.

Please refer to the following table for the mixing ratio.

Ambient temperature	Always
Amount of antifreeze	9 L (2.4 gal)
Amount of water	9 L (2.4 gal)
Ratio	50 %

Our machines are filled with a long-life coolant.

The life of the antifreeze is for two years.

Use non-amine type long-life coolant when changing coolant.

2 OPERATION

⚠ WARNING

- Do not remove the radiator cap while the coolant is hot.
- Hot water may be spouted out that can cause scald. Relieve pressure by slowly turning the cap after the water temperature is dropped, then remove the cap.



2.14.3 DEF

When the DEF inside the tank freezes, it may expand damaging equipment inside the tank or parts.

Fill the tank with the prescribed amount of DEF while it is cold (less than half if there is a danger of freezing).

The DEF freezes at -11°C.

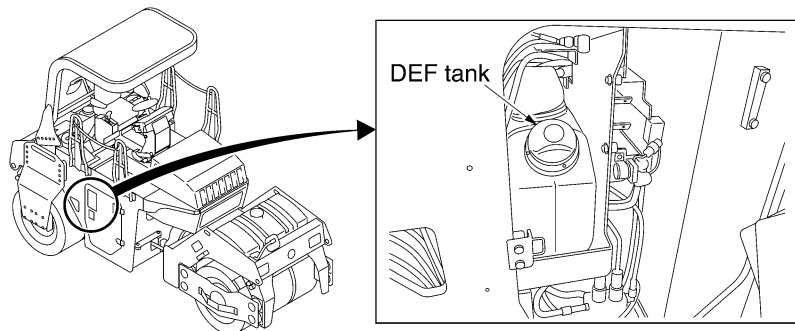

2.14.4 Battery

⚠ WARNING

- The battery contains diluted sulfuric acid, which will dissolve clothes and skin. Should you get battery fluid on your clothes or skin, wash it off immediately with copious quantities of clean water.
- If you get it in your eyes, rinse them straight away with clean water and immediately seek the help of a doctor.
- If you accidentally ingest it, drink copious quantities of water and immediately seek the help of a doctor.
- Always wear safety glasses when handling the battery.
- The battery generates hydrogen gas, so there is a danger of explosions. Avoid recharging the battery, keep cigarettes and flames away, etc., in poorly ventilated places when there is a danger of generating sparks.
- The inspection and handling of batteries should be carried out with the engine turned off and the starter switch in the OFF position.
- Be careful not to accidentally connect the two battery terminals with tools or other metallic objects.
- Tangled terminals may generate sparks due to improper connections, resulting in the danger of explosions. Make sure terminals are connected firmly.
- The battery is for starting the engine and operating electrical equipment on the machine. Do not use it for any other purpose.

When the temperature decreases, the battery capacity will lower, possibly freezing the electrolyte.

The battery should be maintained in a good state at all times, with care taken to keep it warm in preparation for use the next morning.

Check the color of the hydrometer attached to the battery top to charge or replace the battery.

Green·····	Satisfactory (Good)
White·····	Charging is necessary (Charging required)
Red·····	Replacement is necessary (Electrolyte insufficient)

⚠ CAUTION

The power-supply voltage of this machine is 12 V.

2.15 When the Cold Season is Over

When winter is over and the warm season has come, proceed as follows:

- 1) Change oil and fuel with those for use in warm season referring to “Rating” on page 109.
- 2) If AF antifreeze is in use, drain the coolant completely, wash clean inside the cooling system, and then fill with non-amine type long-life coolant.
- 3) Check to make sure there is no damage to parts inside the DEF tank. Carry out repairs if there is any damage.

2.16 For a Long Storage Period

For leaving the machine unused for longer than one month, proceed as follows:

- 1) Store the machine in a closed area after cleaning.
- 2) Conduct oiling, greasing and changing of oil.
- 3) Grease lubricate the exposed portion of hydraulic cylinder piston rods.
- 4) Cover the battery after disconnecting the negative cable or take off the battery from the machine and store in a safe place.
- 5) If the temperature is expected to go down below 0°C, add antifreeze to the coolant.
- 6) Completely drain the sprinkler system.
- 7) Place the F-N-R lever in the neutral position (N), turn the vibrator and sprinkler switches off and apply the parking brake.
- 8) Chock the machine.
- 9) Remove the starter switch key.
- 10) When starting the engine after a long strage (of more than 3 months), activate the starter for about 10 seconds to allow oil to reach every engine part.
- 11) Fill up the DEF tank. However, fill the tank with DEF to less than half full if there is a danger of freezing.

2.17 During the Storage Period

⚠ WARNING

If necessary to operate the machine for anti-corrosive purpose in closed area, ensure good ventilation keeping windows and doors open to prevent gas poisoning.

- During storage, operate the machine at least once a month to prevent the oil films on the lubricated parts from deteriorating and to charge the batteries.
- To prevent the brake linings from sticking to the brake drum, disengage the brake once a month. Exercise care not to allow the machine to move unexpectedly.

⚠ CAUTION

Follow the procedures below if the machine is not used for two months or more after storage.

- **Change the DEF pump filter and fill up the DEF tank before starting the engine.**
- **Check the SCR system to make sure there are no abnormalities after starting the engine.**
- **If there is something wrong with the SCR system, stop the engine and restart it. If there is an abnormality in the SCR system even after restarting the engine, contact one of our sales offices or a factory designated by our company.**
- **If a year or more has passed since refilling the DEF tank, contact one of our sales offices or a factory designated by our company to change the DEF.**
- **Dispose of the drained DEF in accordance with the local environmental laws, rules and regulations.**

Old DEF may give off an ammonium smell. Change the DEF in a well-ventilated place.

2.18 When the Battery Has Discharged

⚠ WARNING

- To check and handle the batteries, keep the engine stopped with the starter switch in the OFF position.
- The batteries give off explosive gases. Do not smoke close to the batteries. Keep flames and sparks away from the batteries.
- The electrolyte is very corrosive and will harm your clothing or skin. If the electrolyte has come into contact with your clothing or skin, flush with sufficient amount of water. In case the electrolyte has gotten into your eyes, flush with water and get medical help.
- To disconnect the battery cables, start with the negative terminal (earth). When connecting, start with the positive terminal. Do not allow a metallic item to bridge between the positive terminal and machine body. This can generate sparks, causing an explosion.
- Loose battery terminals can cause sparks. An explosion will result. When connecting the terminals, make certain that they are tight.

Disconnect with negative cable first

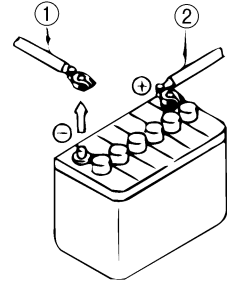

Connect with positive cable first

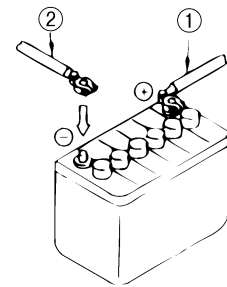

⚠ CAUTION

The power-supply voltage of this machine is 12 V.

2.18.1 Connection and disconnection of booster cables

When jump-starting the engine, connect the booster cables as follows:

■ Connection of booster cables

- 1) Connect one end of the positive booster cable (A) to the positive \oplus terminal of the battery on the machine.
- 2) Connect the other end of the positive booster cable to the positive \oplus terminal of the booster supply.
- 3) Connect the negative booster cable (B) to the negative \ominus terminal of the booster supply.
- 4) Connect the other end of the negative booster cable to a good earth of the engine block of the machine.

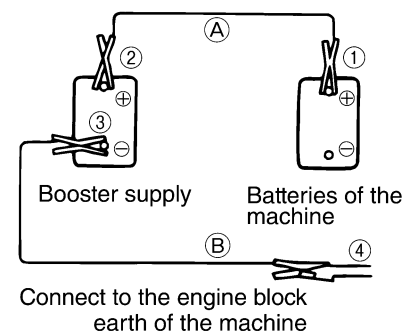

■ Disconnection of booster cables

- 1) Disconnect the negative booster cable (B) from the engine block earth.
- 2) Disconnect the negative booster cable (B) from the booster supply.
- 3) Disconnect the positive booster cable (A) from the booster supply.
- 4) Disconnect the positive booster cable (A) from the machine.

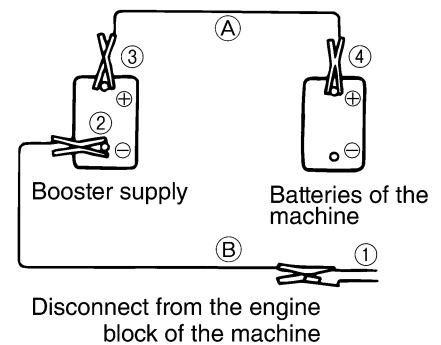

⚠ WARNING

- Do not allow the positive \oplus terminal to make contact with the negative \ominus terminal when connecting the booster cables.
- Wear safety goggles when jump-starting the engine.
- Do not allow the machine to make careless contact with the booster supply.
- Do not make wrong connections. Connect the negative \ominus cable to the engine block earth far away from the battery, as sparks may occur when connecting.

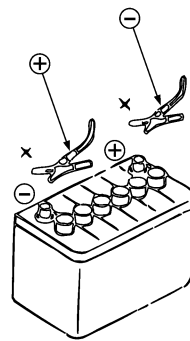

⚠ CAUTION

- Use booster cables and end clips of proper size suited to the battery capacity.
- Use the batteries of the equal capacity for the machine and booster supply.
- Check booster cables and end clips for signs of damage and corrosion.
- Securely connect the clips.
- The power-supply voltage of this machine is 12 V.

3 PERIODICAL MAINTENANCE

3.1 Precautions

Whether or not the inspection service and lubrication are performed at the correct regular intervals exerts significant influence on the occurrence of trouble and service life of the machine. In this manual, typical intervals for inspection and service are given. However, flexibility should be introduced as to interval or type of services to enable your machine to always operate in the best condition.

WARNING

Be sure to take adequate care not to burn yourself when replacing filters, elements, oil, etc.

IMPORTANT

- **After maintenance and inspection record the result of inspection. Remember that replacement of filter elements, replenishment and change of oil and grease, and cleaning the radiator fins are important.
When draining a hot oil, use care not to get burned.**
- **The disposal of waste oil and coolant, and used filters, elements, etc., should be handled by specialized disposal companies.**

General precautions

- 1) Always use SAKAI genuine parts for replacement.
- 2) Use lubricants recommended by SAKAI. Avoid mixing different brand lubricants.
- 3) For hydraulic oil replenishment, changing, level checking, filter cleaning or replacement, oiling and greasing, use extreme care to prevent dust from entering.
- 4) For checking oil level or changing oil, park the machine on a level and hard surface.
- 5) Change oil while warm.
- 6) For a long-term storage, fill the fuel tank, lubricate necessary points and run the machine for more than 20 minutes once a month. Completely fill the DEF tank except during cold times.
- 7) In freezing weather, add antifreeze to the coolant according to the ambient temperature.
- 8) For the hydraulic pump and motor, have them serviced at authorized service shops.
- 9) Contact one of our sales offices or a factory designated by our company to change DEF hoses and clean the DEF tank.
- 10) Turn the starter switch OFF when performing services such as repairing broken wires, short circuits and tightening loose terminals.

Periodical replacement of essential maintenance parts

In order secure safety for work and travel, conduct inspection and services. Further, for enhanced safety, following parts and components should be replaced periodically. These parts are prone to material deterioration due to aging or physical change due to wear, while it is difficult to determine their useful limit by regular inspection, which makes it necessary to replace with new ones after certain period of service to maintain their perfect function.

If any abnormality is detected such as crack, deformation, wear or oil leakage, go ahead and replace them even if it is within scheduled replacement time.

System or Mechanism	Part name	Periodical replacement maintenance part	Replacement period	Remarks
1 Brake system	Master cylinder	Seals (rubber parts)	2 years	
	Wheel cylinder	Seals (rubber parts)	2 years	
	Brake piping parts	Brake hose	2 years	
		Air hose	2 years	
	Operating parts	Cable	4 years	
2 Steering system	Orbitrol	Seals (rubber parts)	2 years	
	Hydraulic piping parts	Hydraulic hose	2 years	
	Steering cylinder	Seals (rubber parts)	2 years	
	Hydraulic pump	Seals (rubber parts)	4 years	
3 Power transmission system (inclusive of axle)	Axle	Seals (rubber parts)	4 years	
	Travel pump	Seals (rubber parts)	4 years	
	Travel motor	Seals (rubber parts)	4 years	
	Hydraulic piping parts	Hydraulic hose	4 years	
	Isolation rubber	Isolation rubber itself	4 years	
4 Fuel system	Piping parts	Fuel hose	2 years	
5 Engine related	Engine mounting parts	Isolation rubber	4 years	
	Seals (rubber parts)	Packing and others	4 years	
	Drive parts	V-belt	2 years	or 500 hours
	Piping parts	Engine drain hose	4 years	
6 Cooling system	Piping parts	Radiator hose	2 years	
		Radiator drain hose	4 years	
7 Control related parts	Cable	Cable	4 years	
8 Intake system	Piping parts	Intake hose	2 years	
		CAC hose	2 years	
9 Hydraulic system	Hydraulic piping parts	Hydraulic hose	4 years	
10 Urea system	Piping parts	Coolant hose for urea system	2 years	
		Urea hose	9,000 hours	

▲ CAUTION

- **With a new machine, change the engine oil, change the engine oil filter element and fuel sedimenter after 50 hours of operation for the first time only (refer to page 85)**
- **When trouble occurs in the location indicated by the indicator lamp on the monitor display, sensor will work and corresponding lamp comes on. If this occurs, conduct necessary service regardless of the periodical service interval recommendation.**
 - 1) **The hydraulic filter (line filter) warning lamp ⇨ Replace elements**
- **Check the electric wiring at a regular interval not exceeding one month, when there is abnormality, replace it.**

If there are some trouble on the electric wiring, replace them with new one.

 - 1) **Damage to the wire harness and loose clamps**
 - 2) **Loose sockets**
 - 3) **Function of electrical systems**
- **For the parts other than listed above, if there are some trouble on the parts at periodical inspection or daily check, replace them as soon as possible.**

3.1.1 Lifting the machine on a hoist

⚠ WARNING

- Get a qualified personnel to lift and lower the machine on a hoist.
- Use sturdy wire ropes.
- Lock articulation by means of steering lock bar located at the center of machine.

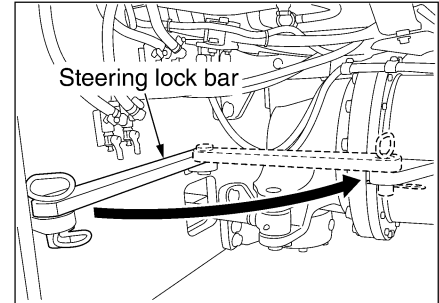

- 1) Put wire ropes securely on the hook and lifting points as shown.

NOTE: Use appropriate wire rope size.

- 2) If wire ropes make contact with other parts of the machine, put pieces of cloth or wooden blocks at the contact points. Carefully perform lifting.
- 3) When lifting, keep the machine properly balanced.

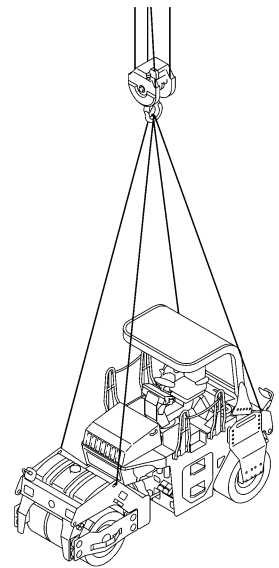

⚠ WARNING

Make sure wire ropes are not damaged.

3.2 Walk-Around Checking

For efficient operation, daily, before-operation checking is very important. Before starting, perform walk-around checking for loose bolts, nuts and signs of leakage in addition to items as shown below:

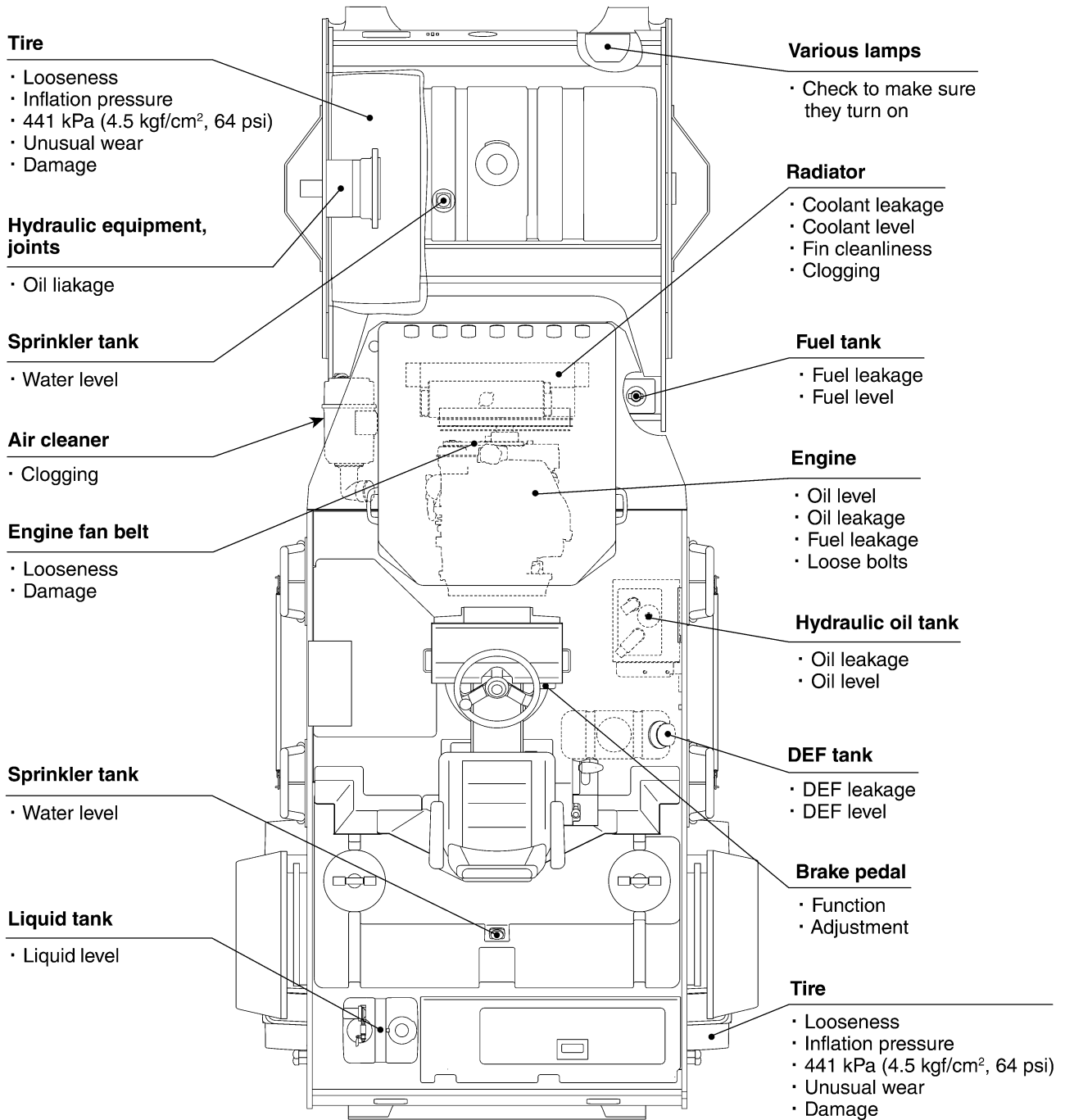

3.2.1 Tire inflation check

Inflation pressure

Use a tire gauge to check the inflation pressure when the tire is cool, to make sure it is 441 kPa (4.5 kgf/cm², 64 psi). Adjust the pressure when it is not at the designated pressure above.

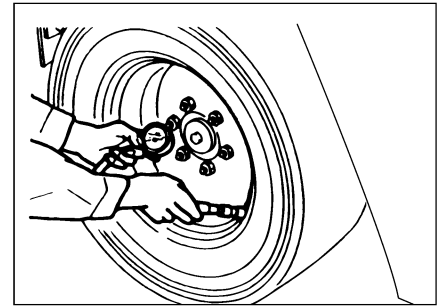

⚠ WARNING

Improper handling of tires have a risk of tire breakage and rim scattering. When checking for the inflation pressure and inflating the tires, do not stand facing the rim, but stand behind the tread of the tire as shown.

3.2.2 Tire damage check

Check the tires for damage and the extent to which they are damaged (Check to see if the damage penetrates to the carcass).

- 1) Check the tire tread for cuts.
- 2) Check the rim for cracks and the rim flange for deformation.

Tires that have problems as listed below are not serviceable. Replace with new ones to secure safety.

- 1) Tire with bead wires damaged or noticeably deformed.
- 2) Tires markedly worn with carcass ply exposed.
- 3) Tires with carcass damaged beyond three thirds of their width.
- 4) Tires having signs of flaking.
- 5) Tires with radiated cracks penetrating to the carcass.
- 6) Tires with marked wear, deformation and damage which make the tires unbearable to use.

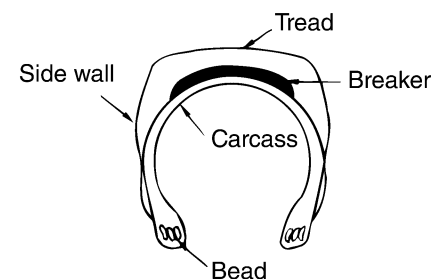

If tires are found to be damaged or huge difference in amount of wear is noticed between the front and rear tires or between the left and right tires or the rim is found to be bent, have them checked by a qualified workshop.

3.3 Periodical Maintenance Points

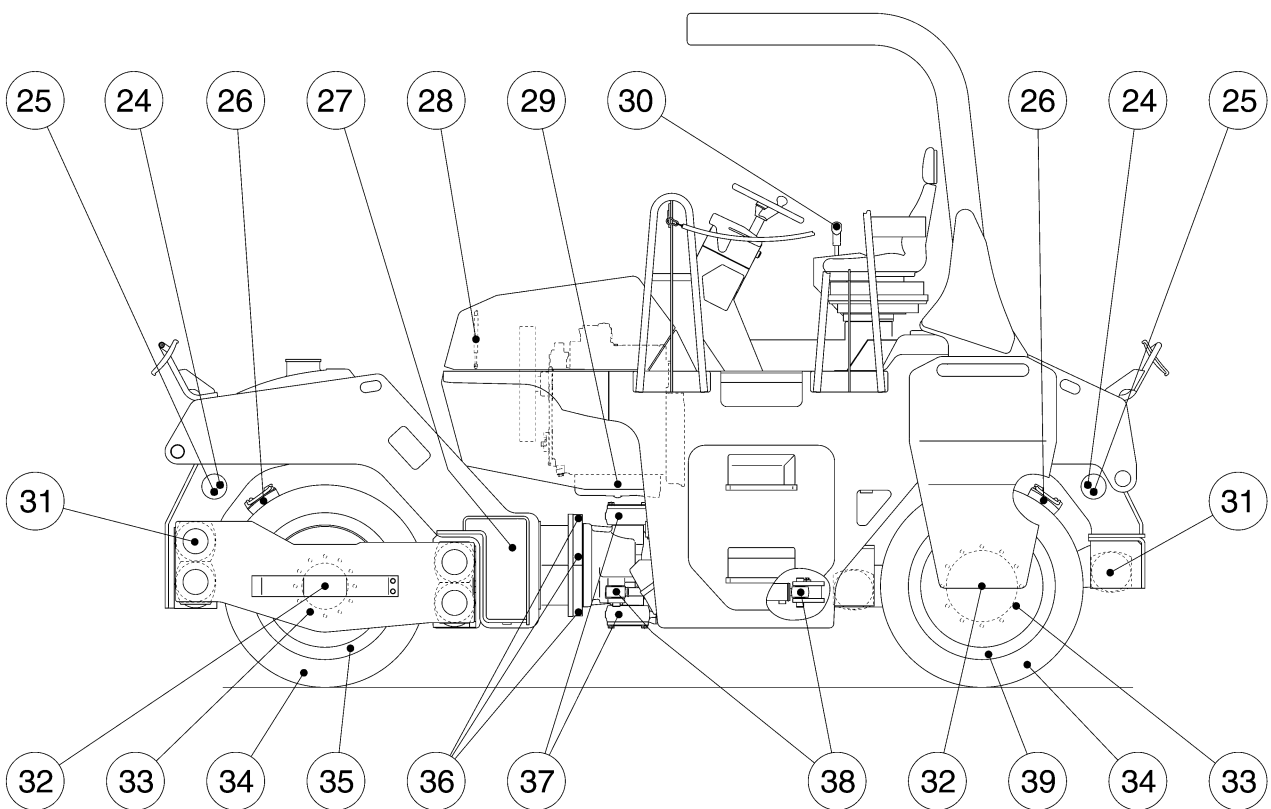
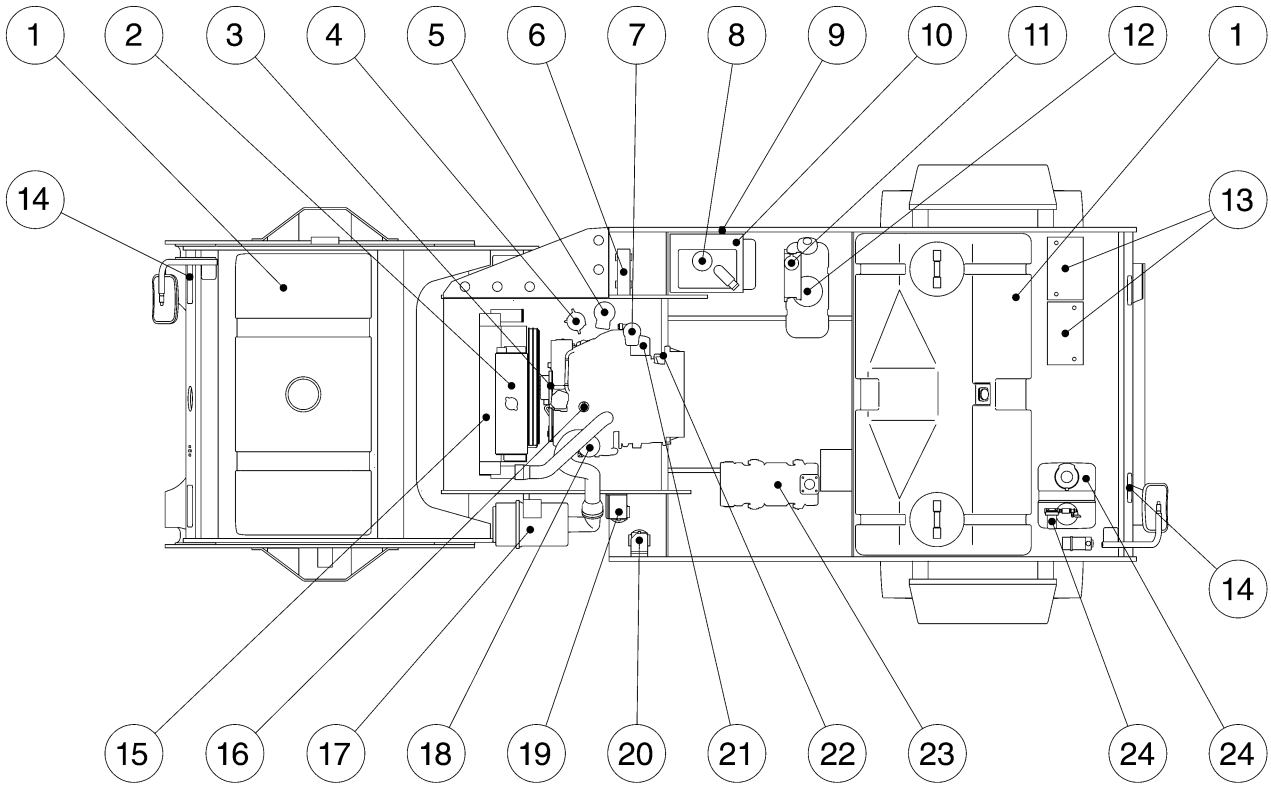

3 PERIODICAL MAINTENANCE

Interval	No.	Item	Service	Lubricant	Q'ty
Every 10 service hours or daily	②	Auxiliary tank	Check coolant level	Coolant	1
	③	Fan belt	Check tension and unusual wear		1
	⑰	Air cleaner	Check indicator		1
	⑳	Engine oil level gauge	Check oil level	Engine oil	1
Every 50 service hours	④	Fuel sedimenter	Check, drain water and sediment		1
	⑥	Splinkler filter	Clean filter element		2
	⑨	Hydraulic oil level geuge	Check oil level, add as necessary	Hydraulic oil	1
	⑬	Battery	Check looseness of terminal and appearance		1
	⑰	Engine oil (First 50 service hours only)	Change engine oil and filter element	Engine oil	1
	㉑	Engine oil filter			
Every 250 service hours	⑳	Tires	Check condition and air pressure		7
	⑳	Rubber dampers	Check for cracks		16
	㉓	Wheel hub bolts	Check looseness		-
	㉕	Vibrator	Check oil leak and oil level	Gear oil	1
Every 500 service hours	㉙	Vibrator	Check oil leak and oil level	Gear oil	2
	④	Fuel sedimenter	Clean inside cup		1
	⑤	Fuel filter	Change filter element		1
	⑦	Fuel pre filter	Change filter element		1
	⑱	Hydraulic oil line filter	Change filter element		1
	㉒	Hydraulic oil return filter	Change filter element		1
	㉖	Engine oil filter	Change filter element		1
	㉘	Engine oil pan	Change engine oil	Engine oil	1
	㉚	Control links	Check looseness and adjust		8
	㉜	Tilt pin bearing	Grease 4 fittings	Grease	4
Every 500 hours or 3 months, or each time after brake pedal is used	㉞	Center pin bearing	Grease 2 fittings	Grease	2
	㉟	Cylinder head and anchor pins	Grease 4 fittings	Grease	4
Every 1000 service hours	㉑	Parking brake	Check function		3
	⑧	Hydraulic oil tank suction filter	Clean filter element		2
	⑩	Hydraulic oil tank	Change hydraulic oil	Hydraulic oil	1
	㉕	Vibrator	Change gear oil	Gear oil	1
Every 1500 service hours	㉙	Vibrator	Change gear oil	Gear oil	2
	⑱	Engine oil separator	Replace filter element		1
Every 3000 service hours	⑪	DEF pump filter	Change filter element		1
	㉓	DPF	Clean inside, filter element Clean or Replace filter element	DPF	1
As required	①	Water tank	Clean inside tank		2
	⑫	DEF tank	Check DEF level, add as necessary	DEF	1
	⑭	Lighting	Bulb burn-out inspection		1
	⑮	Radiator	Clean fins		1
	⑰	Air cleaner	Clean element, replace elements as necessary		1
	㉒	Liquid tank, filter, pipe and nozzle	Clean or replacement		-
	㉔	Sprinkler pipe and nozzle	Clean or replacement		-
	㉖	Scrapers	Adjust and clean or replacement		7
	㉘	Fuel tank	Drain water and dirt		1
㉚	Gas dampers	Check injury or replacement		2	

IMPORTANT

- Ensure that the 10 hour maintenance is carried out and that there are no loose bolts, nuts or oil leaks before starting.
- No.19, 20 : Carry out servicing when the monitor lamp lights up, besides following the instructions shown above.

3.4 Maintenance Procedure

➔ For servicing the engine, see the separate engine manual.

(1) Every 10 hours or daily

② Auxiliary tank

Check to see coolant level in the sight glass, if coolant can not be seen, replenish with the Auxiliary tank cap removed.

Use soft water only.

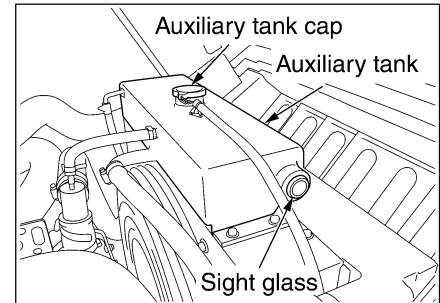

⚠ WARNING

- Do not remove the radiator cap while the coolant is hot.
 - Hot water may be spouted out that can cause scald.
- Relieve pressure by slowly turning the cap after the water temperature is dropped, then remove the cap.



NOTE: Replace long-life coolant every two years.

③ Fan belt

➔ See the separate engine manual.

Check the fan belt for wear and damage. Replace as necessary.

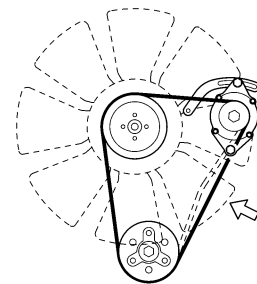

⚠ WARNING

Make certain that the engine is completely stopped to avoid any risks when checking looseness, tensions and damages for the fan belts. Also make certain that the key is removed from the key cylinder.

17 Air Cleaner

When the red float of the dust indicator reaches the service level (a mark on the indicator), clean the element (refer to page 104).

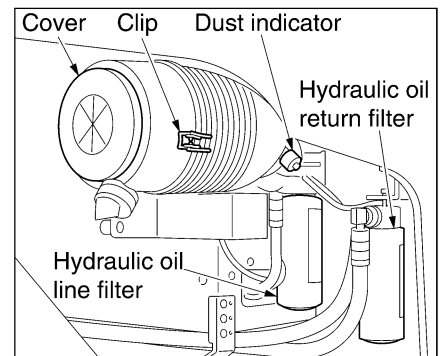

22 Engine oil level gauge

➔ See the separate engine manual.

Check the amount of engine oil after the engine is completely stopped. Pull out the oil level gauge and wipe off oils by waste clothes. Re-insert the oil level gauge into the full length of the oil dip pipe and pull it out. Check that the oil level is between MAX and MIN. In case of shortage, feed oils through the engine oil fill port.

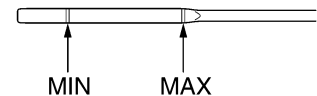
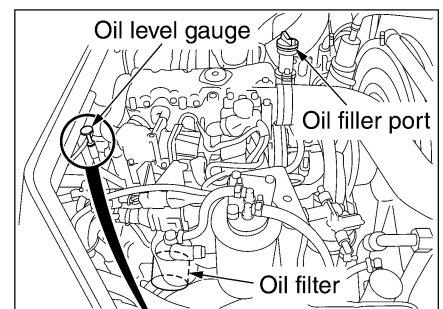

NOTE: When checking the amount of oils after running the engine, please check at least 5 minutes after the engine is stopped. If the machine is inclined, please move it to the flat ground before start checking it.

The engine oil level may rise

In engines installed with DPFs, some fuel may become mixed into the engine oil during cleaning (burning) of the DPF, diluting (increasing the amount of) the engine oil. If the level rises above the maximum level on the engine oil gauge, change the oil immediately as it may cause the engine to break down.

⚠ WARNING

It may cause scald immediately after that the engine is stopped because the temperature of the parts and the oils may be raised. Please start checking it by waiting until the temperature is dropped.

⚠ CAUTION

Be sure to use engine oil recommended by SAKAI (refer to page 109).

(2) Every 50 hours

④ Fuel sedimenter

➔ See the separate engine manual.

Check the float level. If it comes up to the level mark, open the drain cock at the bottom and drain water.

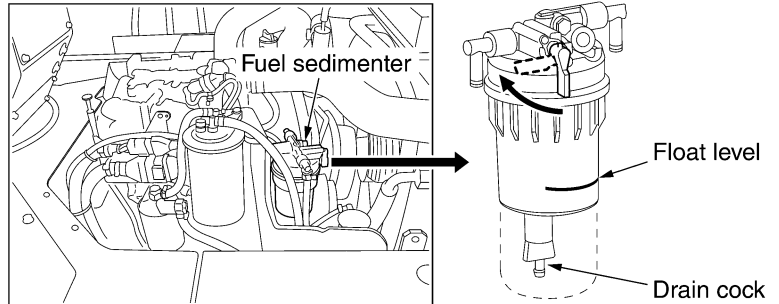

NOTE: After purchasing a new machine, drain water 50 hours after the initial operation.

⑥ Sprinkler filter

Take off the filter bowl by turning counterclockwise as viewed from the bottom. Clean the element.

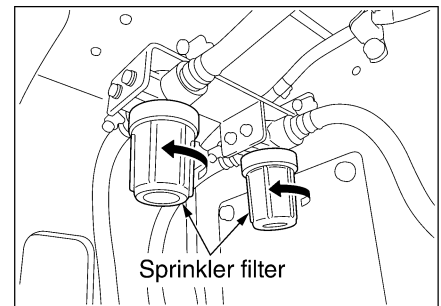

⑨ Hydraulic oil level gauge

Check the oil level with the sight glass on the side of tank. The level is proper if it is between H and L marks. If necessary, add the hydraulic fluid from the filler port.

CAUTION

Be sure to use hydraulic oil recommended by SAKAI (refer to page 109).

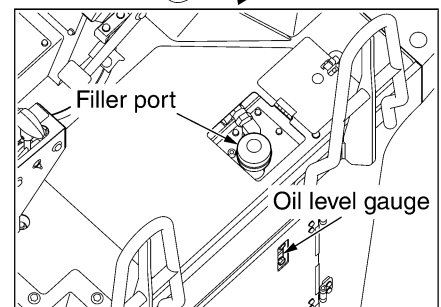
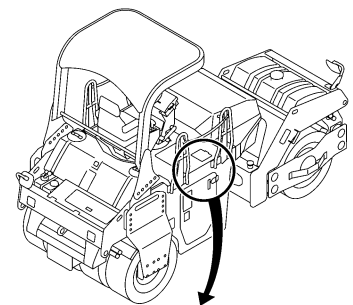

13	Battery
----	----------------

1) Check the color of the hydrometer attached to the battery top to charge or replace the battery.

- | | | |
|-------|-------|--|
| Green | | Satisfactory (Good) |
| White | | Charging is necessary
(Charging required) |
| Red | | Replacement is necessary
(Electrolyte insufficient) |

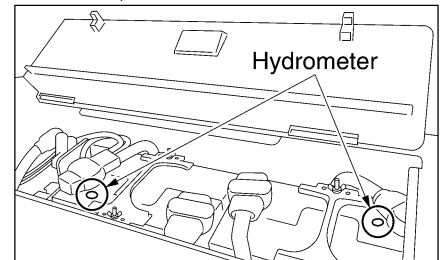
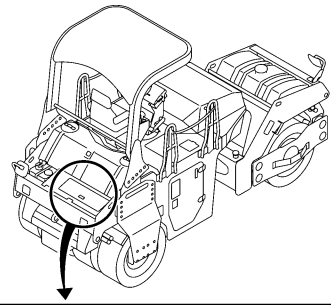

⚠ WARNING

- The battery contains diluted sulfuric acid, which will dissolve clothes and skin. Should you get battery fluid on your clothes or skin, wash it off immediately with copious quantities of clean water.
- If you get it in your eyes, rinse them straight away with clean water and immediately seek the help of a doctor.
- If you accidentally ingest it, drink copious quantities of water and immediately seek the help of a doctor.
- Always wear safety glasses when handling the battery.
- The battery generates hydrogen gas, so there is a danger of explosions. Avoid recharging the battery, keep cigarettes and flames away, etc., in poorly ventilated places when there is a danger of generating sparks.
- The inspection and handling of batteries should be carried out with the engine turned off and the starter switch in the OFF position.
- Be careful not to accidentally connect the two battery terminals with tools or other metallic objects.
- Tangled terminals may generate sparks due to improper connections, resulting in the danger of explosions. Make sure terminals are connected firmly.
- The battery is for starting the engine and operating electrical equipment on the machine. Do not use it for any other purpose.

⚠ CAUTION

- The power-supply voltage of this machine is 12 V.
- Use only batteries recommended by SAKAI (refer to page 104).

- 2) Retighten any loose terminal. Apply grease or vaseline to the terminals to retard rusting.
- 3) Be sure to tighten the battery holder if it is loose.

3 PERIODICAL MAINTENANCE

⑩ Engine oil filter

⑪ Engine oil

First 50 service hours only (refer to page 92).

⑬ Tires

- 1) Check for unusual wear and damage.
- 2) Check for the inflation pressure (441 kpa (4.5 kgf/cm², 64 psi)).
- 3) Check the wheel bolts for looseness simultaneously.

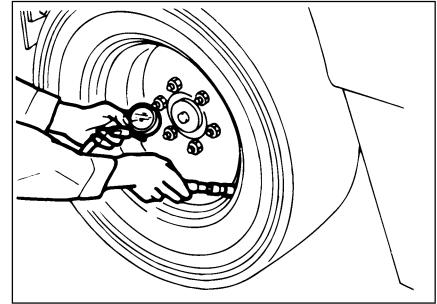

⚠ WARNING

Improper handling of tires have a risk of tire breakage and rim scattering.
When checking for the inflation pressure and inflating the tires, do not stand facing the rim, but stand behind the tread of the tire as shown.

(3) Every 250 hours

⑭ Rubber dampers

Check the rubber dampers for cracks, and their mounting bolts for looseness.

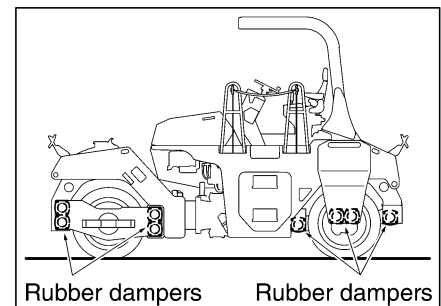

⑮ Wheel hub bolt

Check the wheel hub nut for looseness. If it is loose, tighten it.
Be sure to torque it to the specified value.

Tightening torque: **265 N·m**

⚠ WARNING

- Turn the wheel hub bolt in the tightening direction during inspection.
- Excessive tightening of the wheel hub nut will lead to breakage of bolts or cracks in the disc wheel. Be sure to observe the specified torque.

NOTE: Tighten the wheel hub bolt 50 hours after purchase of a new machine or replacement of tires.

35/39 **Vibrator**

Check for the oil leakage.

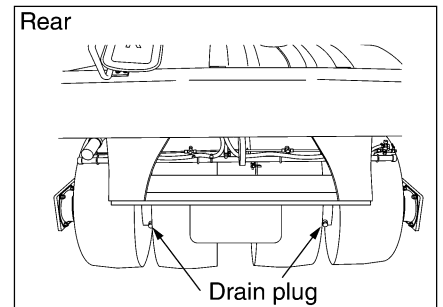
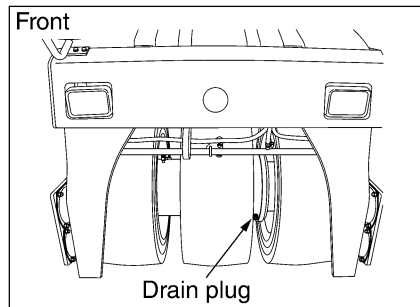

(4) Every 500 hours

④ **Fuel sedimenter**

Clean the fuel sedimenter.

Cleaning

- 1) Set the water separator handle to the "CLOSE" position.
- 2) Loosen and remove the cup proper, and clean its inside with diesel oil.
- 3) Tighten up the cup proper.

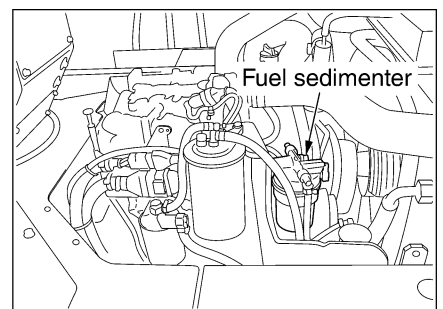

⑤ **Fuel filter**

⑦ **Fuel pre-filter**

➔ See the separate engine manual.

Change the filter cartridge.

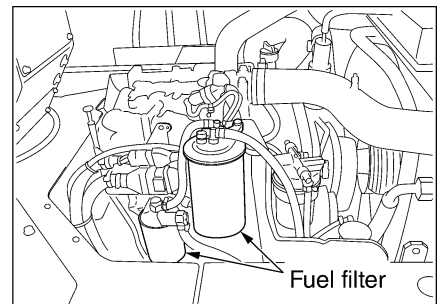

⑱ **Hydraulic oil line filter**

⑳ **Hydraulic oil return filter**

Turn the filter elements counterclockwise and replace a new one.

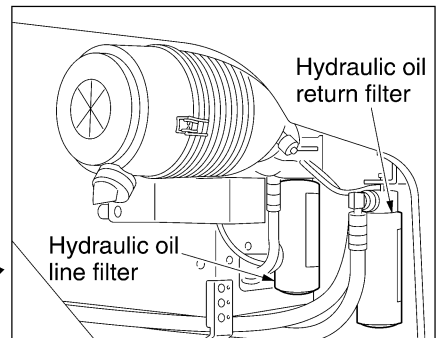
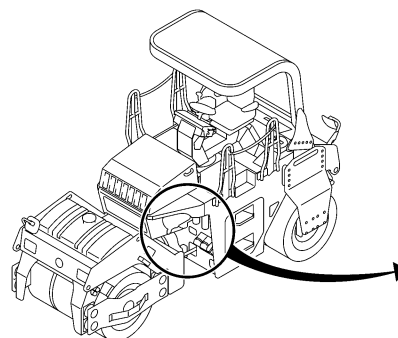

3 PERIODICAL MAINTENANCE

⑳ Engine oil filter

㉑ Engine oil pan

➔ See the separate engine manual.

- 1) After completion of operation and while the oil is warm, drain the oil with the drain plug removed.

⚠ WARNING

When draining a hot oil, use care not to get burned.

- 2) Refit the drain plug and fill the crankcase with the engine oil from the fill port on the cylinder head cover.

⚠ CAUTION

- Be sure to use engine oil recommended by SAKAI (refer to page 109).
- Change the engine oil if the intervals between DPF regenerating become less than 5 hours.

- 3) Change the oil filter element.

NOTE: For a new machine, change oil and oil filter element at 50 operating hours for the initial time only.

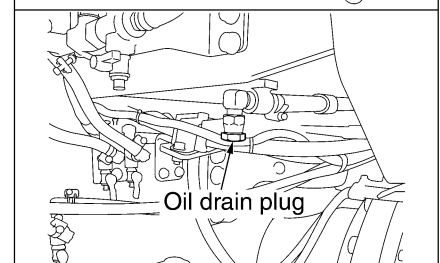
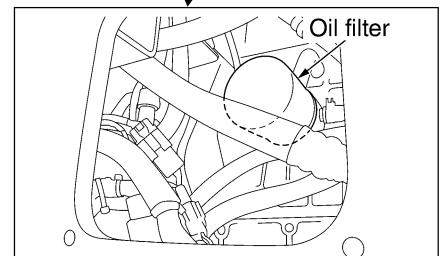
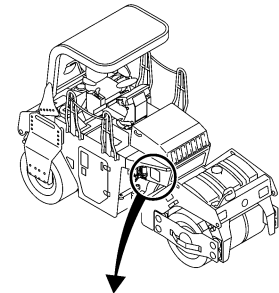
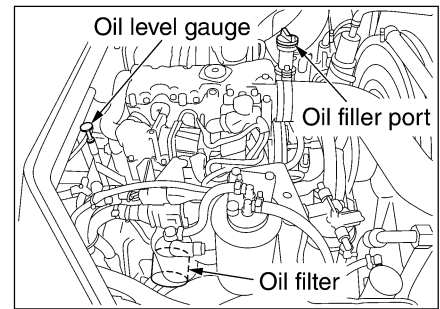

30 Control links

Remove the cover under the dashboard.
 Check the bolts and nuts for looseness (indicated ➔
 6 places). Adjust the operating force of the F-N-R lever
 and speed shift lever by bolts and nuts (A).

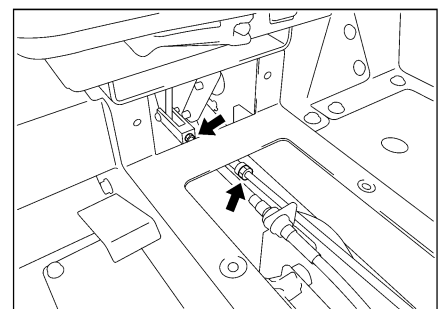
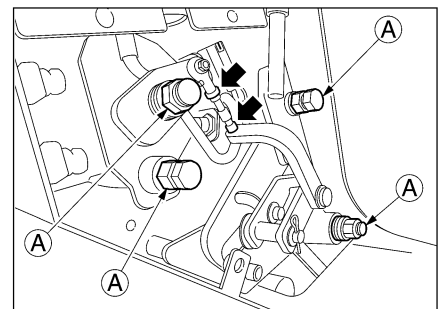
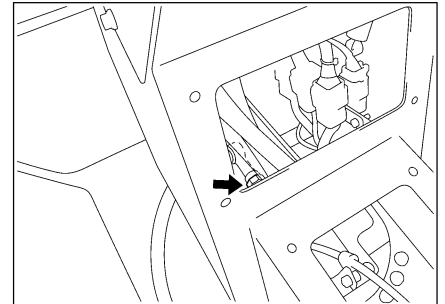
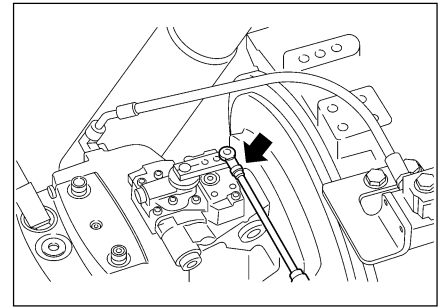

3 PERIODICAL MAINTENANCE

③⑥ Tilt pin bearing

Grease lubricate four locations.

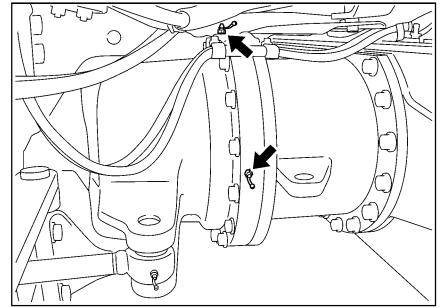

③⑦ Center pin bearings

Grease lubricate two locations.

▲ CAUTION

Be sure to use grease oil recommended by SAKAI (refer to page 109).

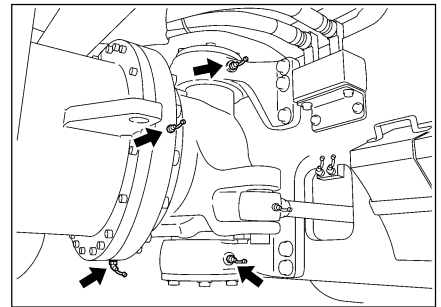

③⑧ Cylinder head and anchor pins

Grease the right / left cylinder heads and anchor pins.

▲ CAUTION

Be sure to use grease oil recommended by SAKAI (refer to page 109).

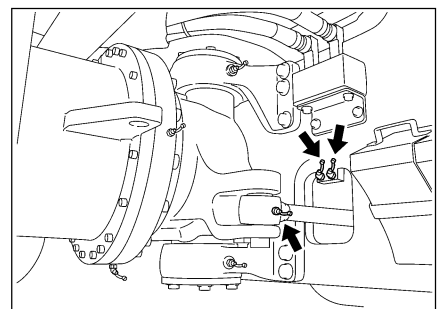
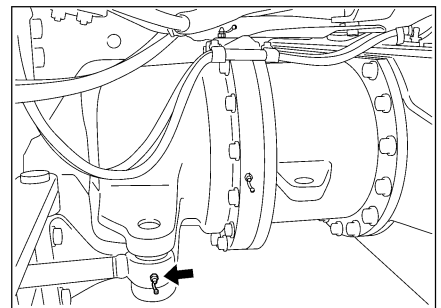

(5) Every 500 hours or 3 months, or each time after brake pedal is used

③② Parking brake

⚠ WARNING

- Ensure safety by checking to make sure there is no one and no obstacles near the machine.
- Keep your hands on the F-N-R lever and steering wheel during inspections.
The machine may move in unexpected ways during inspections, leading to accidents.

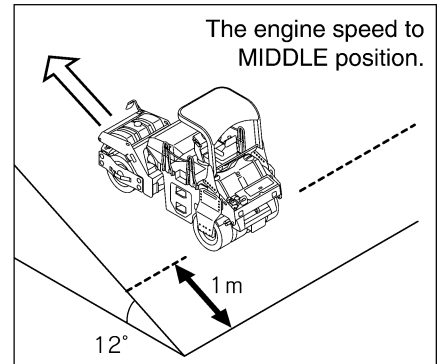

- 1) Adjust the engine speed to MIDDLE position.
- 2) Be sure to move the machine onto asphalt pavement or another hard surface with an upward inclination of 12° (20%) with the engine left on.
- 3) Press the parking brake switch (P) to engage the parking brake. Check that the OK monitor lamp (P) has turned on.
If the lamp (P) does not turn on, contact one of our sales offices or a factory designated by our company for advice.
- 4) Remain seated on the machine to make sure it remains completely still for 1 minute. If it moves, move it immediately to flat ground, stop using it, contact one of our sales offices or a factory designated by our company, and have it repaired.

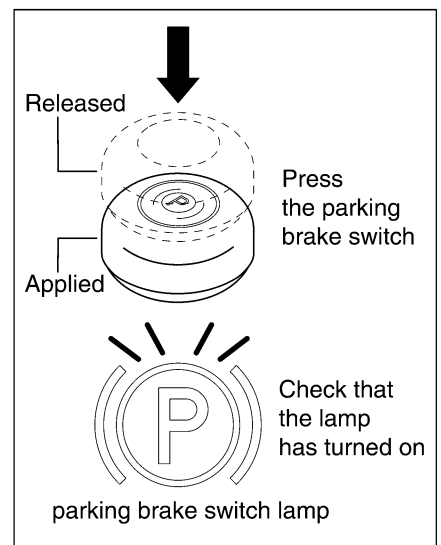

⚠ WARNING

- This inspection must be carried out after each use of the brake pedal.
If the inspection is not carried out, the parking brake may malfunction when you try to use it next time causing a serious accident.
- Making alterations to the machine.
Please do not make alterations to the machine without permission for safety reasons. We shall not be held responsible for injuries, death or breakdowns caused by alterations.

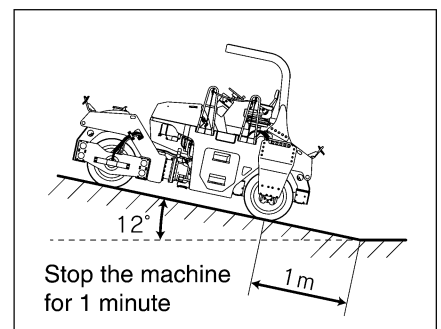

3 PERIODICAL MAINTENANCE

(6) Every 1000 hours

⑧ Hydraulic oil tank suction filter

Take off the hydraulic tank cover. Take out and clean the strainer, change the strainer if necessary.

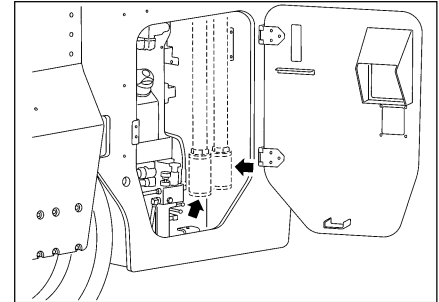

⑩ Hydraulic oil tank

- 1) Remove the drain plug and drain the oil while it is warm.
- 2) After cleaning the inside of the tank, fill the tank to the specified level with new hydraulic oil.
- 3) Start and run the engine at idling for 2 – 5 minutes. When air bubbles have disappeared from the oil, stop the engine and check the oil level again.

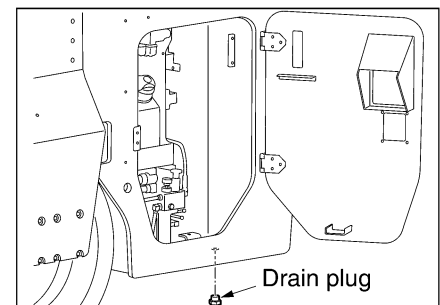

⚠ WARNING

When draining a hot oil, be careful not to get burned.

⚠ CAUTION

Be sure to use hydraulic oil recommended by SAKAI (refer to page 109).

35 39 **Vibrator**

- 1) Rotate the drum till the drain plug comes to bottom.
- 2) Remove the drain.
- 3) Drain the vibrator oil.
- 4) Turn the tire until the port comes to a position for easy oiling.
- 5) Supply specified amount of oil (Front 3.2 L, Rear 2.5 L x 2) through the port using a jug, etc.
- 6) Wash clean the removed plugs, and refit the drain plug.

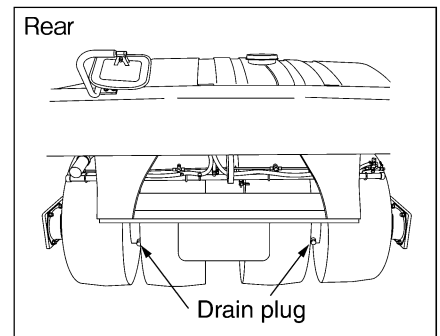
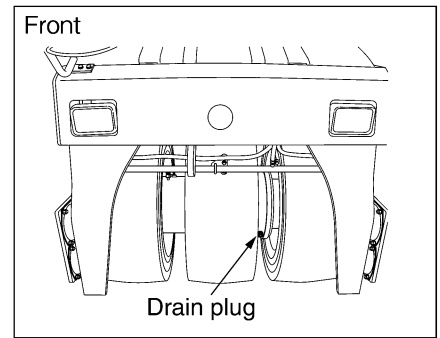

⚠ WARNING

When draining a hot oil, use care not to get burned.

⚠ CAUTION

Be sure to use gear oil recommended by SAKAI (refer to page 109).

(7) Every 1500 hours

18 **Engine oil separator**

Open the cover, take out the oil separator element, wipe off the oil, and replace it with a new one.

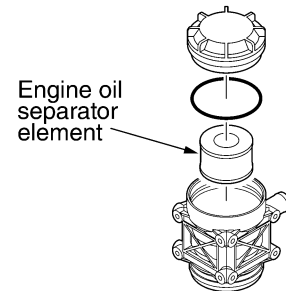

(8) Every 3000 hours

11 **DEF pump filter**

➔ Refer to 3.5.1 Changing the DEF pump filter (refer to page 106).
Change the DEF pump filter element.

23 **DPF**

Ash accumulates in the filter when a DPF is used for a long time. The accumulation of too much ash will lower the performance of the DPF.
Contact one of our sales offices for advice on how to clean the DPF.

3 PERIODICAL MAINTENANCE

(9) As required

① Water tank

- 1) With the drain cap and filler cap removed, remove the water and sediment from the bottom of the tank.
- 2) If sedimentation is substantial, clean the interior of the tank.
- 3) When the necessary work is complete, refit the drain cap and filler cap.

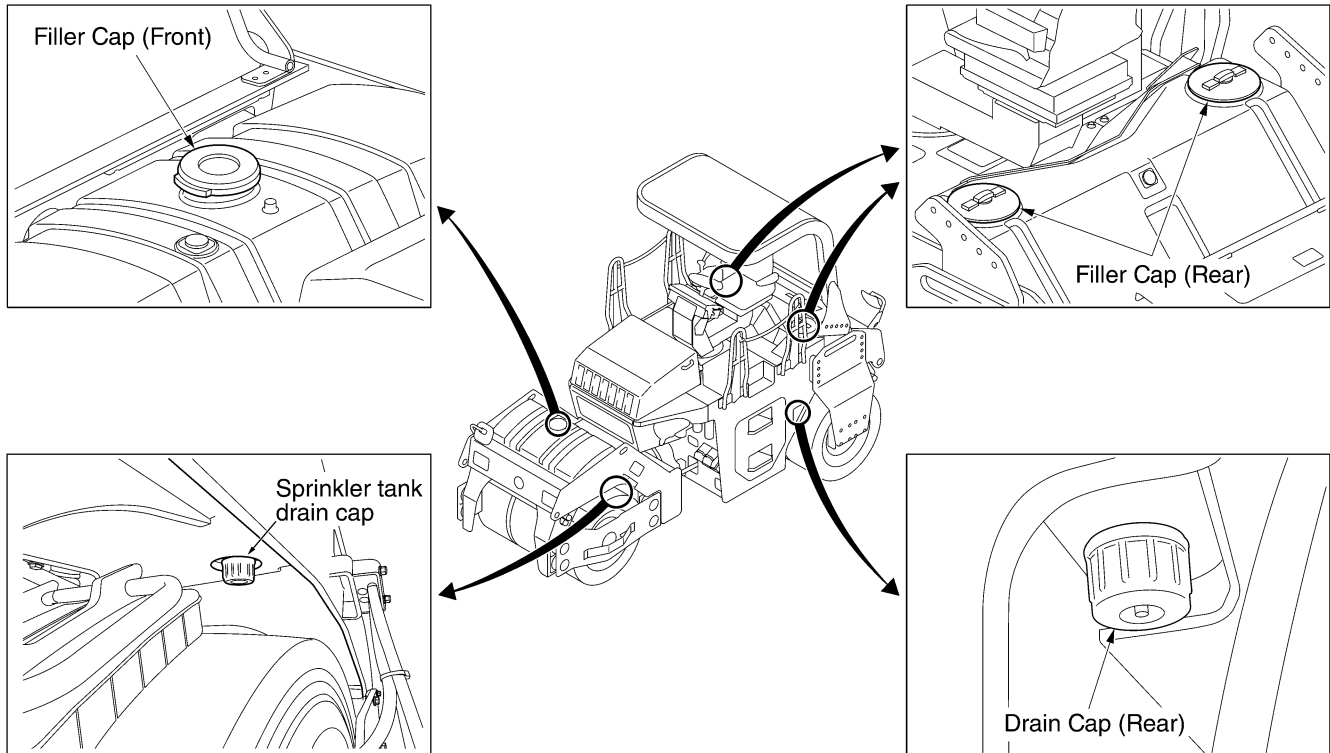

⑫ **DEF tank**

Check the DEF level
If it is inadequate, remove the filler cap and fill the tank through the filler port.

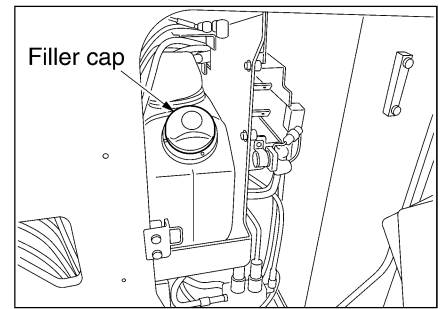

⚠ CAUTION

Be sure to use the DEF recommended by SAKAI (refer to page 109).

⑭ **Lighting**

Make sure that all the electric bulbs (indicator and warning lamps inside the monitor display, headlamps and Flood lamps) light up or blink by operating switches on the operation panel. If they do not light up, replace them with new ones.

⑮ **Radiator**

Clean the cooling fins.

3 PERIODICAL MAINTENANCE

17 Air cleaner

➔ See the separate engine manual.

When the red moving piece of the dust indicator reaches the service level (mark on the dust indicator), clean the outer element in the manner shown below.

- 1) Open the hood, remove the clip on the air cleaner case, and remove the cover.
- 2) Pull the outer element straight out of the element case so as not to damage the outer element.
- 3) Blow compressed air from the inside of the outer element for cleaning. The air pressure shall not exceed 205 kPa (2.1 kgf/cm², 30 psi). If the element has scratches, holes, or oil spots, replace it with a new one.

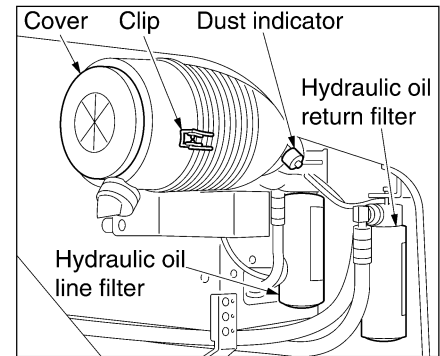

⚠ WARNING

- Stop the engine before inspection, cleaning, or maintenance, otherwise dust will enter the engine, causing the breakdown of the engine.
- Wear protective goggles, a dust respirator, and other protective gear before cleaning the air cleaner and outer element in order to prevent dust from entering your eyes or nose.
- Be sure to use our genuine element.

- 4) Attach the outer element and clamp it with a clip.
- 5) Press the dust indicator reset button.

⚠ CAUTION

- If the red moving piece of the dust indicator still reaches the service level after the outer element has been cleared, replace the outer element with a new one.
- Do not use air cleaners or elements other than those designated by our company. Failure to do so may cause deterioration in performance due to errors in the sensor.

NOTE: In normal use, change the element once in every 6 cleanings.

②④ Liquid tank, filter, pipe and nozzle

1) Liquid tank

Open the drain valve to drain the liquid.
Remove the filler cap from the liquid tank to clean the inside of the tank. Close the drain valve and replace the liquid tank filler cap.

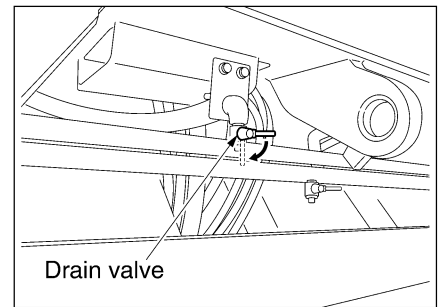

2) Liquid filter

Turn the filter case counter-clockwise to remove it, and clean the element inside.

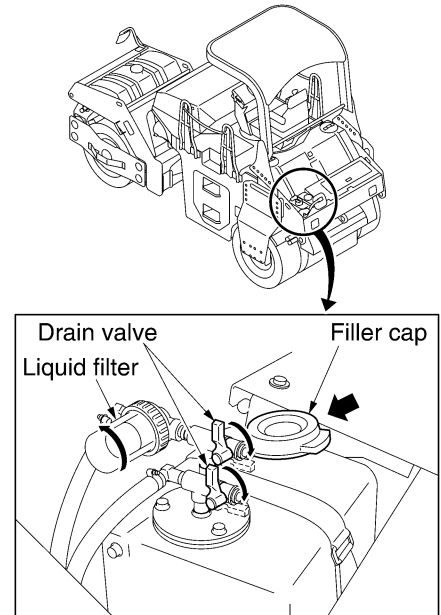

3) Liquid pipe

Remove the cap from the end of the liquid pipe.
Operate the liquid switch to wash out dust from inside the pipe along with the liquid.

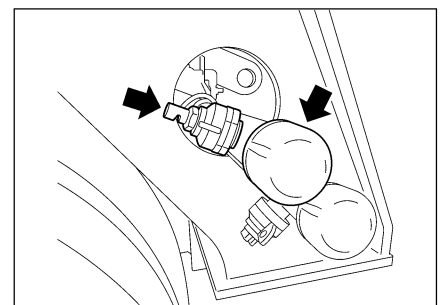

4) Liquid nozzle

- Turn the cap of the “one-touch” nozzle to remove the cap and nozzle from the liquid pipe.
- Unscrew the nozzle from the cap to remove it.
- Clean the nozzle hole with a needle or something similar, before reattaching it to the liquid pipe in reverse order to how it was removed.
- When screwing the nozzle into the cap, make sure that the spraying of the liquid is directed across the width of the tire.

NOTE: The nozzle hole and O-ring of the sprinkler nozzle are different from those of the liquid nozzle. Do not use the sprinkler nozzle as the liquid nozzle

3 PERIODICAL MAINTENANCE

25 Sprinkler pipe and nozzle

1) Spray pipe

Remove the cap from both ends of each spray pipe.
Operate the spray pump to wash out dust from inside the pipe.

2) Nozzle

- Remove the nozzles from the spray pipe and separate the filter from each nozzle.
- Clean the filters. Use a needle or the like to clean nozzle hole. Refit the filters to the nozzles.
- Fit the nozzles to the pipes so that the water is sprayed in the form of a hand fan in parallel with the pipe.

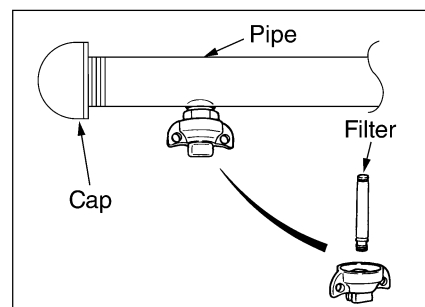

26 Scraper

When the gap between the roll and blade has grown large, adjust the scraper properly.

To clear muds accumulated between the roll and scraper blade, raise the blade.

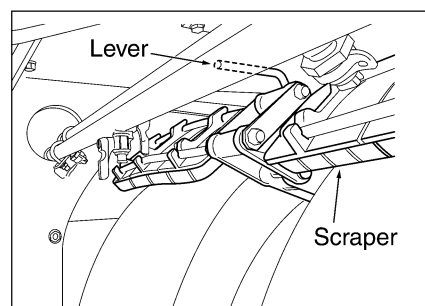

⚠ WARNING

Be careful not to pinch your fingers between the roll and blade.

Refer to page 42 for adjustment.

27 Fuel tank

- 1) With the drain plug removed, remove the water and sediment from the bottom of the tank.
- 2) If sedimentation is substantial, remove the drain plug and clean the interior of the tank.
- 3) When the necessary work and refueling are complete, tighten the filler cap positively.

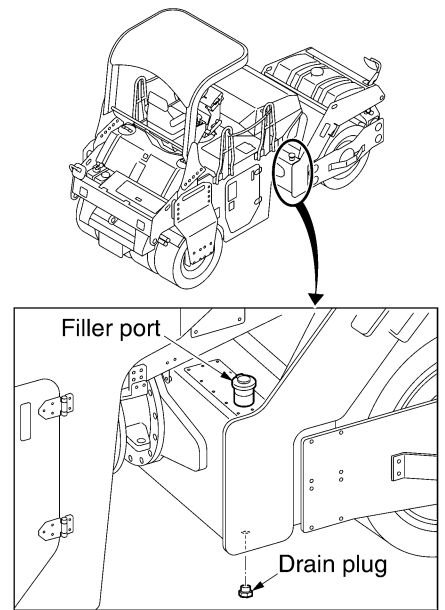

⚠ WARNING

- The fuel will catch fire if open flames or ignition sources are used close to it.
- Do not smoke or use a match or cigarette lighter close to it.



NOTE: When removing the water and sediment from the tank filled with the fuel, the fuel will gush out if the drain plug is screwed out completely.

28 Gas damper

Open the hood and check to make sure it is held up by the gas dampers. If it is not, replace the gas dampers.

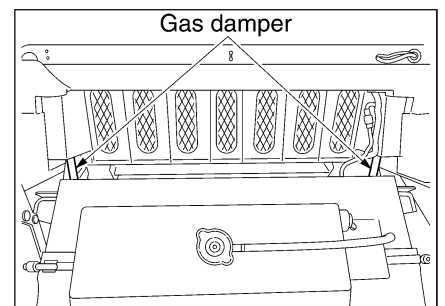

3 PERIODICAL MAINTENANCE

3.5 Consumable Parts

Replace consumable parts such as filter elements and air cleaner elements during periodical maintenance or before reaching the wear limit. Proper replacement of consumable parts will improve the overall life of the machine, resulting in cost-effective operations.

Use genuine SAKAI parts as replacement parts.

The part numbers are subject to change due to the improvements to the parts. When ordering parts, make sure to obtain the latest part numbers by checking with our distributorship or one of our certified service shops of the version, model name and model number of the machine in use.

Consumable Part	Part No.	Interval		Remark
		Annual replacement (year)	Replacement per operation (hours)	
Engine oil filter element	4032-71010-0		500	
Engine oil separator element	4033-32024-0		1500	
Fuel pre-filter assembly	4032-71016-0		500	
Filter element	4032-71011-0		500	
Fuel filter assembly	4033-32006-0		500	
Filter element	4033-37005-0		500	
Fuel sedimenter assembly	4033-32008-0		As required	
Element	4033-37022-0		As required	
Air cleaner assembly	4423-85000-0		As required	
Inner element	4422-37001-0	1	Replacement simultaneously with the outer element	
Outer element	4419-53001-0	1	After cleaning 6 times	
Suction filter element (Hydraulic oil)	4207-79000-0		1000	Clean or replacement
Suction filter element (Hydraulic oil)	4208-36000-0		1000	Clean or replacement
Line filter assembly (Hydraulic oil)	4218-71000-1		500	
Return filter assembly (Hydraulic oil)	4218-71000-1		500	
Filter element	4211-41004-1		As required	
Sprinkler filter assembly	4715-98000-0		As required	
Sprinkler filter element	4715-98001-0		As required	
Sprinkler nozzle assembly	4710-41000-0		As required	
Nozzle	4710-41004-0		As required	
O-ring	4710-41003-0		As required	
Strainer	4710-41005-0		As required	Clean or replacement
Liquid spray nozzle assembly	4715-86000-2		As required	
Nozzle	4715-86003-0		As required	
O-ring	4715-86002-0		As required	
Strainer	4715-86011-0		As required	
Gas damper	4418-04000-0	1		
Battery	4906-11000-1		As required	115D31R
DEF pump filter element	4033-74059-0		3000	
DEF tank filter	4033-74065-0		8000	

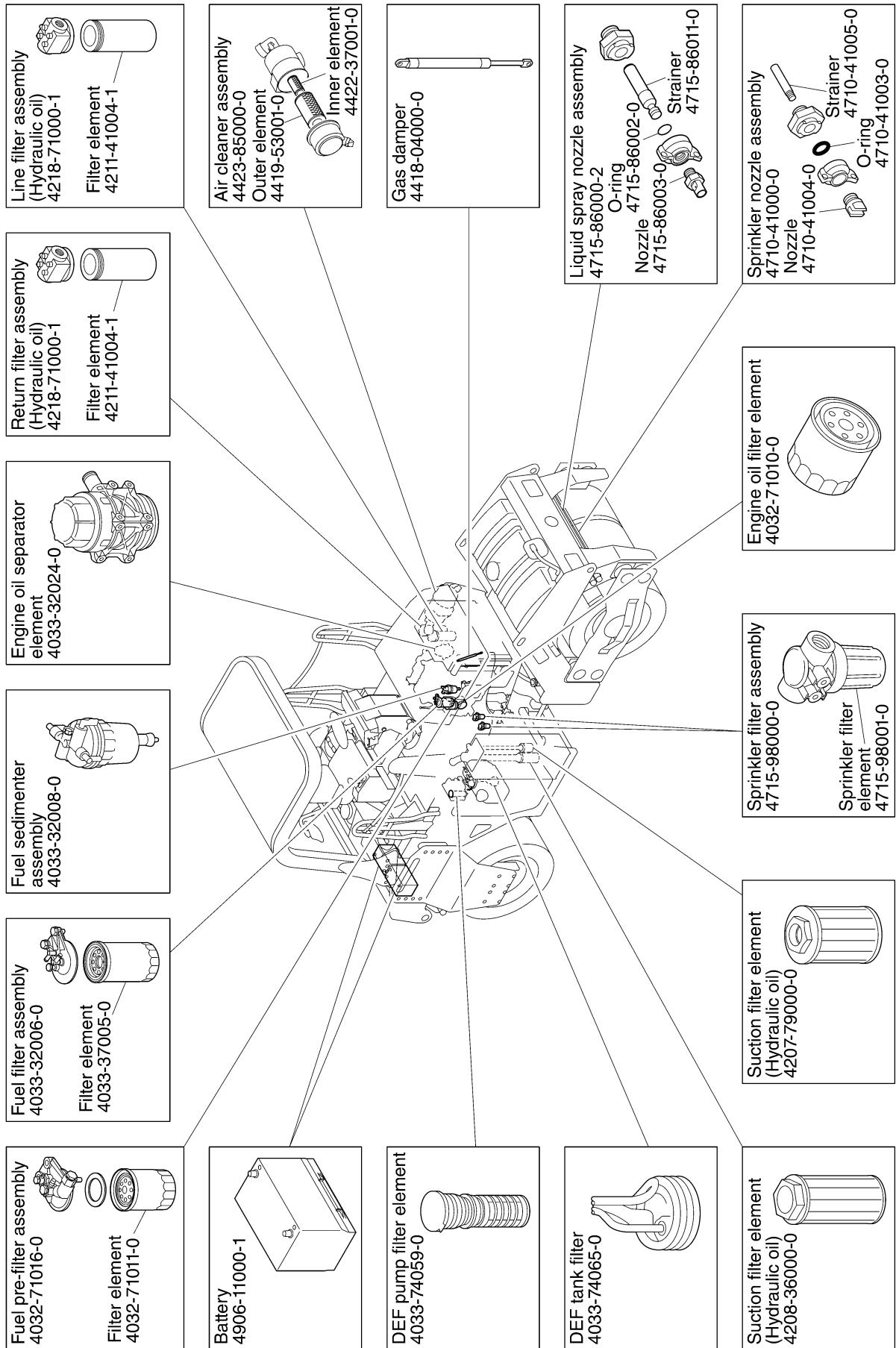

3.5.1 Changing the DEF pump filter

⚠ WARNING

The filter cannot be changed immediately after turning off the engine, because the outside will be hot. Change it after everything has cooled down.

IMPORTANT

- Use genuine SAKAI products for replacement parts.
- Driving the machine without a DEF filter, or using non-genuine SAKAI filters may lead to breakdowns due to contaminants entering the DEF pump or DEF injector. Never drive the machine without a DEF pump filter, or a non-genuine SAKAI filter.
- The DEF pump filter cannot be washed. Washing it will lower its performance, causing breakdowns in the DEF pump and DEF injector. The element must never be reused.
- If the DEF pump filter is not assembled properly, it may cause the DEF to leak. Follow the correct procedures when changing the DEF pump filter.
- The DEF freezes at -11°C . Freezing makes changing the filter difficult. Change the filter when the surrounding temperature exceeds -11°C , so that the DEF will not freeze.
- Discharged / used DEF from lines during service cannot be reused or SCR system malfunction may result.

To prevent freezing of the DEF and malfunctions caused by precipitation of urea after the engine is turned off, the DEF machine system automatically sucks out the DEF remaining inside the DEF injector and DEF pump, and returns it to the tank.

The machine continues running for several minutes after the engine is turned off, so clean the area around the DEF pump after the DEF system has stopped running, before changing the filter.

The DEF pump filter is located at the top of the DEF pump.

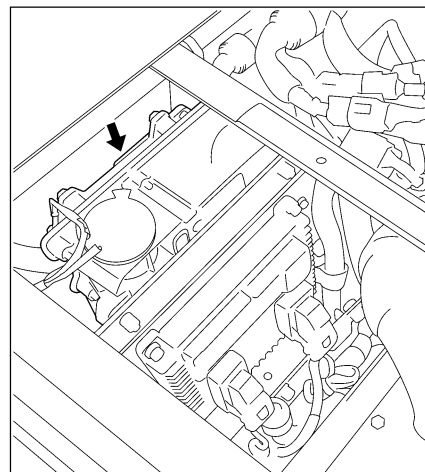

3.5.2 Replacement of filter in DEF

⚠ WARNING

**To avoid personal injury or death:
Dispose of discharged/used DEF properly in accordance with local regulations.**

- 1) Set the starter switch to the **OFF** position. Wait for 2 minutes or longer for the supply module to get deactivated.
- 2) Remove the protection cap. Loosen the cover and draw out the filter.
- 3) Install the new filter and cover.
- 4) Tighten the cover to the correct tightening torque.
- 5) Install the new protection cap in place.

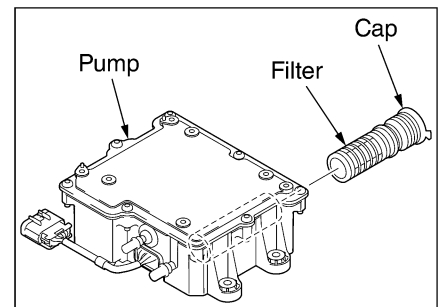

Torque Value: 9 – 11 N·m [80 – 95 in-lb]

3.6 Fluid and Lubricant Capacities

(1) General rules

- 1) Never feed water or lubricant with the strainer removed.
- 2) Use recommended lubricant and hydraulic fluid.
- 3) Do not use lubricants and hydraulic fluid of different brands.
- 4) When replacing oil, drain it completely and clean the container with flushing oil before filling new oil.
- 5) When fueling SAKAI machines, be sure to use the fuel that we specify or recommend. Nonconformance resulting from use of fuel and lube oil other than those specified or recommended by our company is not covered by our warranty and repair service.

(2) Capacity

Compartment	Type of fluid	Capacity in liters (gal.)
Fuel tank	Diesel oil	130 (34.3)
Engine oil pan	Engine oil	13 (3.4)
Radiator	Coolant	18 (4.8)
Hydraulic oil tank	Hydraulic oil	90 (23.8)
Vibrator (Front)	Gear oil	3.2 (0.85)
Vibrator (Rear)	Gear oil	2.5 (0.66) × 2
Water tank	Water	Front : 280 (74.0) / Rear : 450 (118.9)
DEF tank	DEF	20 (5.3)

⚠ WARNING

- **DEF on the skin may cause inflammation in some people, so contaminated clothes, shoes, etc., should be taken off and washed in cold or warm water. If there are any changes in appearance or pain, promptly seek medical help.**
- **If the DEF is accidentally swallowed, rinse out your mouth well with water, and promptly seek medical help.**
- **If the DEF gets in your eyes, rinse it out immediately in clean water for several minutes, then promptly seek medical help.**
- **Wear protective glasses when there is a danger of the DEF splattering. Wear rubber gloves if work requires you to come into contact with the DEF.**
- **Do not put anything other than DEF into the DEF tank. Diesel, gasoline, etc., in particular may cause fires. Moreover, putting additives in the tank may lead to generation of toxic gases.**
- **Opening the DEF tank cap may release toxic ammonia gas. When opening the cap or filling the tank, keep your face away from the filler port.**
- **If the DEF is spilled, promptly wipe it clean and wash with water. Neglecting to do so may lead to toxic gases or corrosive substances being given off.**

⚠ CAUTION

- Put AUS32 or ISO22241-1 certified DEF in the DEF tank.
Using anything else may cause breakdowns in the DEF SCR system.
- Keep the DEF tank topped up by refilling it at the right time.
- Keep the area around the DEF tank cap clean at all times, and take care not to allow contaminants to enter the DEF tank when opening the cap.
- When storing the machine for a month or more, fill up the DEF tank.
- On cold days, fill the tank to the designated level.

(3) Rating

Lubricant	Service classification	Ambient temp. and applicable viscosity rating			Applicable standards
		-15 – 30°C (5 – 86°F) Cold	0 – 40°C (32 – 104°F) Moderate	15 – 55°C (59 – 131°F) Tropical	
Engine oil	API grade CJ-4	SAE 10W-30	SAE 10W-30	SAE 10W-30	MIL-L-2104B
Gear oil	API grade GL5	SAE 80W-90	SAE 90	SAE 140	MIL-L-2105
Hydraulic oil	Anti wear	ISO-VG32 over VI 140	ISO-VG46 over VI 140	ISO-VG68 over VI 110	ISO-3448
Grease	Lithium type extreme pressure				NLGI-2
Fuel	Diesel oil				ASTM D975-2D
DEF	ISO22241-1 or AUS32				

3 PERIODICAL MAINTENANCE

(4) Storing the DEF

- Keep DEF containers airtight, and store them indoors in a well ventilated place avoiding direct sunlight.
- Use the container that the DEF was bought in to store it. Never store it in other containers as it will lead to loss of quality.
- Commission the disposing of the DEF to an industrial waste treatment company to make sure it is handled appropriately. Moreover, DEF containers are to be treated as industrial waste, so they too, must be disposed of in the same way.
- The temperature requirements and storage period for DEF are as shown below:

Temperature during storage	Storage period
Below 10°C	Up to 36 months
Below 25°C	Up to 18 months
Below 30°C	Up to 12 months
Below 35°C	Up to 6 months

(5) Recommended lubricants

Lubricant Oil company	Engine oil API-CJ4	Gear oil API GL 5	Hydraulic oil ISO-VG 46	Grease (NLGI-2)
CHEVRON	DELO 400 LE	RPM Universal Gear Lubricants	Rando HDZ 46	Martifak EP 2
BP	—	BP Energear HYPO-U	Bartran HV 46	BP Energrease LS-EP 2
CASTROL	Tection Extra	EXP Gear OILS	Castrol Hyspin AWH 46	Castrol Spheerol ELP 2
EXXON MOBIL	Mobil Delvac 1 ESP	Mobilube HD	Mobil DTE 10 Excel 46	Mobilux EP 2
SHELL	Shell Rimula R4 L	Shell Spirax S2 A90	Shell Tellus S2V 46	Shell Alvania Greases EP2

⚠ CAUTION

- **Fill the fluid reservoirs with the filters installed.**
- **Use recommended fuels and lubricants only.**
- **Use the hydraulic oils which specifications are as clean as ISO4406 18 / 13 or above.**

3.7 Electric Wiring Diagram

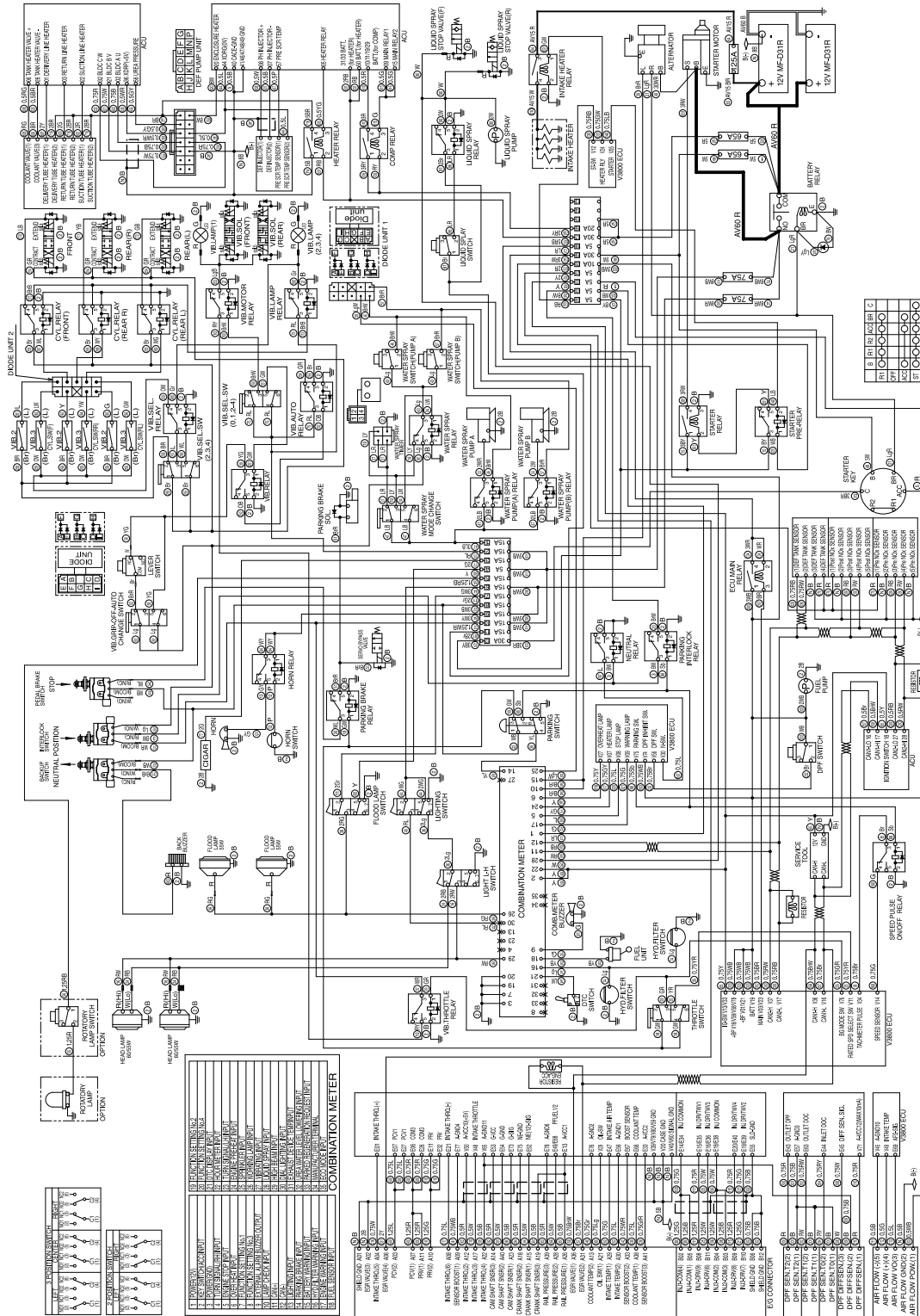

CAUTION: Size of wires not indicated by letters are AV 0.85.

Color of wire

Color	Wire Size
Blue/Black stripe	LB
White/Green stripe	WG
Yellow/Red stripe	YR
Yellow/White stripe	YW
Brown/Black stripe	BR
Yellow/Black stripe	BY
Blue	Sb
Black/Green stripe	BG
White/Red stripe	WR
Yellow	Y
Yellow/Black stripe	YB
Yellow/Green stripe	YG
Yellow/Light blue stripe	YL
Red/White stripe	RW
Red/Yellow stripe	RY
White	W
White/Black stripe	WB
White/Light blue stripe	WL
Red/White stripe	LR
Blue/Red stripe	BR
Blue/White stripe	BW
Blue/Yellow stripe	BY
Light green	Lg
Light blue	L
Orange	O
Pink	P
Red	R
Red/Black stripe	RB
Red/Green stripe	RG
Red/Light blue stripe	RL
Green/Red stripe	GR
Green/White stripe	GRW
Green	G
Green/Black stripe	GB
Green/Light blue stripe	GL
Light red	LR
Light white	LW
Light yellow	LY
Light green	Lg
Light blue	L
Black	B
Black/Red stripe	BR
Black/White stripe	BW
Black/Yellow stripe	BY
Brown	Br

3 PERIODICAL MAINTENANCE

Fuse box

The fuse box houses five 5 A-, one 10 A-, ten 15 A-, two 20 A-, and three 30 A- fuses lined up with spares fitted for one 5 A-, one 10 A-, three 15 A-, two 20 A- and one 30 A- fuses.

⚠ CAUTION

Use fuses of correct capacity.

NOTE: When a fuse is burned, determine the cause before replacing.

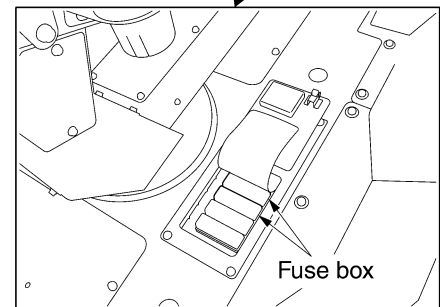
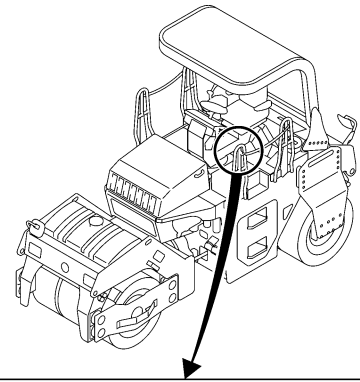

Battery

- ★ Leaving the battery unused for long without attention or its power excessively at a time can cause damage to the plates, leading to a shortened life.
- ★ For long-term storage, charge it fully, tighten the caps securely, store in a cool and dry place, and check the level of charge at least once a month.
- ★ Keep the battery in a satisfactory condition at all times.
- ★ The battery should be in a satisfactory condition when the engine is to be started on cold days. Avoid starting the engine with the battery in a poor condition at any time.

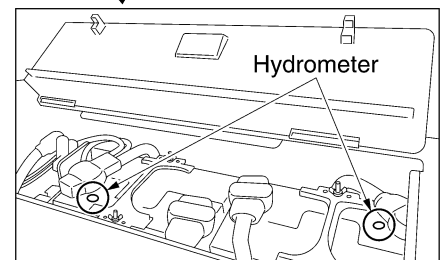
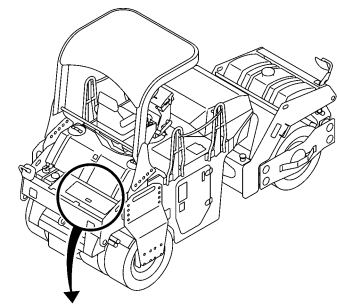

⚠ WARNING

- The battery contains diluted sulfuric acid, which will dissolve clothes and skin. Should you get battery fluid on your clothes or skin, wash it off immediately with copious quantities of clean water.
- If you get it in your eyes, rinse them straight away with clean water and immediately seek the help of a doctor.
- If you accidentally ingest it, drink copious quantities of water and immediately seek the help of a doctor.
- Always wear safety glasses when handling the battery.
- The battery generates hydrogen gas, so there is a danger of explosions. Avoid recharging the battery, keep cigarettes and flames away, etc., in poorly ventilated places when there is a danger of generating sparks.
- The inspection and handling of batteries should be carried out with the engine turned off and the starter switch in the OFF position.
- Be careful not to accidentally connect the two battery terminals with tools or other metallic objects.
- Tangled terminals may generate sparks due to improper connections, resulting in the danger of explosions. Make sure terminals are connected firmly.
- The battery is for starting the engine and operating electrical equipment on the machine. Do not use it for any other purpose.

⚠ CAUTION

The power-supply voltage of this machine is 12 V.

4 SPECIFICATIONS

4 SPECIFICATIONS

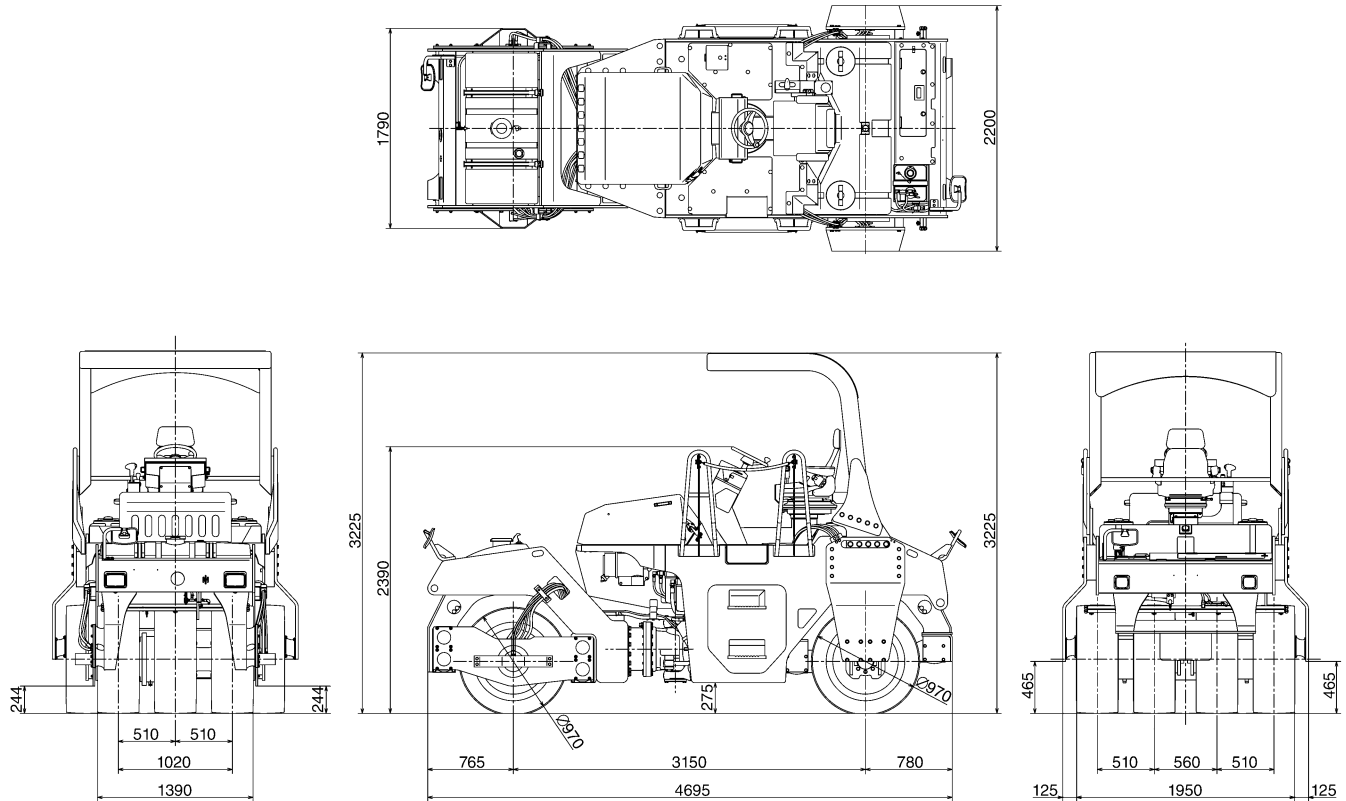

Model	GW754	
Operating weight:		
Operating weight	8,850 kg (19,510 lbs)	
On front axle	3,680 kg (8,115 lbs)	
On rear axle	5,170 kg (11,395 lbs)	
Dimension:		
Overall length	4,695 mm (185")	
Overall width	2,200 mm (87")	
Overall height	3,225 mm (127")	
Wheelbase	3,150 mm (125")	
Wheel		
Front	Tire x 3 14 / 70 - 20 - 12PR	
Rear	Tire x 4 14 / 70 - 20 - 12PR	
Performance:	1st	2nd
Travel speed (forward / reverse)	0 – 6 km/h (0 – 3.7 mile/h)	0 – 12 km/h (0 – 7.5 mile/h)
Vibrating power:		
Centrifugal force	1 st 8 kN (1,800 lbs)	3 rd 42 kN (9,440 lbs)
	2 nd 25 kN (5,620 lbs)	4 th 58 kN (13,040 lbs)
Gradeability	20 degrees	
Rolling width	1,950 mm (77")	
Minimum turning radius	5.9 m (233")	
Engine:		
Model	KUBOTA "V3800-CR-TI-EV03"	
	Diesel Engine with turbo chager	
Total displacement	3.769 litres (230 cu.in)	
Rated output	81.8 kW {110 HP} / 2,400 min ⁻¹	
Max. torque	379.3 N·m / 1,500 min ⁻¹	
Tank capacity:		
Fuel tank	130 liters (34.3 gal)	
Hydraulic tank	90 liters (23.8 gal)	
Sprinkler tank	Front 280 liters (74 gal) Rear 450 liters (118.9 gal)	

NOTE: 1) Gradeability is the calculated value. It may vary with ground surface conditions.

2) According to European Standards (EN500-1, ISO 6165, etc.), the mass are defined as follows.

Operating mass : Fuel=50%, Water=50%, Operator=75kg.

SAKAI HEAVY INDUSTRIES, LTD.

Head Office: 1-4-8, Shiba Daimon, Minato-ku,
Tokyo, Japan

Telephone: 81-3-3431-9971

Facsimile: 81-3-3436-6212

SAKAI HEAVY INDUSTRIES, LTD.