

R2H-2

SHOP MANUAL

SAKAI®

3498-66344-0

Introduction

This manual provides important information to familiarize you with safe operating and maintenance procedures for your SAKAI roller. Even though you may be familiar with similar equipment you must read and understand this manual before operating or servicing this unit.

Safety is everyone's business and it is one of your primary concerns. Knowing the guidelines presented in this manual will help provide for your safety, for the safety of those around you and for the proper operation and maintenance of the machine. Improper operation is dangerous and can result in injury or death.

Sakai Heavy Industries cannot foresee all possible circumstances or varying conditions to which the operator, serviceman or machine may be exposed to that might lead to a potential hazard. Therefore, the warnings and cautions listed in this manual and those placed on the machine are not intended to be all inclusive and liability for personal injury or damage to equipment or property cannot be assumed.

All information, specifications and illustrations in this publication are based on the product information available at the time that the publication was written. The contents may change without prior notice due to modifications of the model.

CONTENTS

1. SAFETY

1. GENERAL SAFETY

1-1. Understanding the Safety Symbols and Words	1-001
1-2. General	1-001
1-3. Qualifications of Operators and Maintenance Personnel	1-002
1-4. Safety Practices and Policies.....	1-002
1-5. Pre Start Inspection.....	1-003
1-6. Safety Instructions	1-003
1-7. Starting.....	1-004
1-8. Operating.....	1-004
1-9. Stopping	1-004
1-10. Maintenance.....	1-005
1-11. Transporting the Machine.....	1-007

2. SPECIFICATIONS

1. SPECIFICATION DATA	2-001
2. TABLE OF STANDARD VALUES	
2-1. Engine.....	2-003
2-2. Propulsion.....	2-003
2-3. Hydraulic System.....	2-003
2-4. Steering.....	2-004
2-5. Brakes.....	2-004
2-6. Capacities.....	2-004
3. FUEL AND LUBRICANTS SPECIFICATION	
3-1. Rating	2-005
3-2. Recommended Lubricants	2-005
4. TIGHTENING TORQUE CHART.....	2-006

3. ENGINE AND CONTROLS

1. ENGINE

1-1. Engine Mount	3-001
1-2. Engine Exterior.....	3-002

2. CONTROL SYSTEM

2-1. Throttle Control.....	3-003
2-2. Forward-reverse Control	3-004

3. PUMP MOUNT	
3-1. Pump Mount	3-005
3-1-1. Installation of pump	3-006

4. HYDRAULIC SYSTEMS

1. SYSTEM CIRCUIT DIAGRAM	
1-1. Graphic Symbols for Hydraulic Circuits	4-001
1-2. Hydraulic Circuit Diagram	4-003
2. PROPULSION HYDRAULIC SYSTEM	
2-1. Propulsion Hydraulic Piping	4-004
2-1-1. Propulsion hydraulic piping (Front 1)	4-004
2-1-2. Propulsion hydraulic piping (Front 2)	4-005
2-1-3. Propulsion hydraulic piping (Rear)	4-006
2-2. Hydraulic Component Specifications	4-007
2-2-1. Hydraulic pump assembly (propulsion + steering + charge)	4-007
2-2-2. Propulsion hydraulic motor (front)	4-009
2-2-3. Propulsion hydraulic motor (rear)	4-011
3. STEERING SYSTEM	
3-1. Steering Hydraulic Piping	4-013
3-2. Steering Wheel	4-014
3-3. Hydraulic Component Specifications	4-015
3-3-1. Orbitrol	4-015
3-4. Frame (Center Pin)	4-016

5. ELECTRICAL SYSTEM

1. ELECTRICAL CIRCUIT	
1-1. Electrical Circuit Diagram	5-001
2. ELECTRICAL COMPONENTS	
2-1. Electrical Component Layout (1)	5-002
2-2. Electrical Component Layout (2)	5-003
3. ELECTRICAL COMPONENT SPECIFICATIONS	
3-1. Fuse Box	5-004
3-2. Combination Meter	5-005

6. DRUM

1. PRECAUTIONS FOR DISASSEMBLY AND REASSEMBLY	6-001
2. FRONT DRUM	6-003
3. REAR DRUM	6-004

7. BRAKE

- 1. BRAKE PEDAL 7-001
- 2. BRAKE SYSTEM..... 7-002

8. WATER SPRAY SYSTEM

- 1. WATER SPRAY PIPING 8-001

9. INSPECTION AND ADJUSTMENT

- 1. INSPECTION AND ADJUSTMENT
 - 1-1. Safety Precautions for Inspection and Adjustment..... 9-001
 - 1-2. Preparation for Inspection and Adjustment 9-001
 - 1-3. Precautions for Inspection and Adjustment..... 9-001
 - 1-4. Warm-up..... 9-001
 - 1-5. Inspection and Adjustment of Engine Related Items 9-001
- 2. MEASUREMENT AND ADJUSTMENT OF PROPULSION CIRCUIT PRESSURE
 - 2-1. Measurement 9-002
 - 2-2. Adjustment..... 9-003
- 3. MEASUREMENT AND ADJUSTMENT OF PROPULSION CHARGE CIRCUIT PRESSURE
 - 3-1. Measurement 9-004
 - 3-2. Adjustment..... 9-005
- 4. MEASUREMENT OF PROPULSION SERVO CIRCUIT PRESSURE
 - 4-1. Measurement 9-006
- 5. MEASUREMENT OF Machine HIGH/LOW SPEED CHANGE CIRCUIT PRESSURE
 - 5-1. Measurement 9-007
- 6. MEASUREMENT OF PARKING BRAKE RELEASE PRESSURE
 - 6-1. Measurement 9-008
- 7. MEASUREMENT AND INSPECTION OF STEERING CIRCUIT PRESSURE
 - 7-1. Measurement 9-009
 - 7-2. Inspection 9-010
- 8. MEASUREMENT OF HYDRAULIC PUMP CASE PRESSURE
 - 8-1. Measurement of Propulsion Pump Case Pressure 9-011
- 9. MEASUREMENT OF PROPULSION MOTOR CASE PRESSURE
 - 9-1. Measurement of Front Propulsion Motor 9-012
 - 9-2. Measurement of Rear Propulsion Motor..... 9-013
- 10. ADJUSTMENT OF THROTTLE LEVER LINKAGE
 - 10-1. Adjustment..... 9-014

11. ADJUSTMENT OF F-R LEVER LINKAGE

11-1. Adjustment	9-015
------------------------	-------

10. TROUBLESHOOTING

1. TROUBLESHOOTING

1-1. Safety Precautions for Troubleshooting	10-001
1-2. Important Information for Troubleshooting	10-001
1-3. Before Starting	10-002
1-4. Wire Color Code and Number	10-002

2. ELECTRICAL SYSTEM TROUBLESHOOTING

2-1. When Performing Electrical System Fault Diagnosis	10-003
2-1-1. Precautions to take during electrical circuit fault diagnosis	10-003
2-1-2. Inspection procedures using a tester	10-004
2-1-3. Inspection of electrical system	10-009
2-2. Engine	10-012
2-2-1. Engine will not start (Starter motor does not run) 1/3	10-012
2-2-1. Engine will not start (Starter motor does not run) 2/3	10-014
2-2-1. Engine will not start (Starter motor does not run) 3/3	10-016
2-2-2. Engine will not start (But starter motor runs)	10-018
2-2-3. Engine does not stop running	10-018
2-2-4. No charging	10-020
2-2-5. Glow plug is not heated (Engine starting performance is bad in cold weather)	10-020
2-2-6. Starter motor runs even when F-R lever is not at neutral	10-020
2-3. Propulsion	10-022
2-3-1. Machine moves neither forward nor backward	10-022
2-3-2. Machine speed cannot be changed	10-024
2-3-3. Brake cannot be released	10-026
2-3-4. Brake does not work	10-028
2-4. Water Sprays	10-030
2-4-1. Continuous water spray does not operate	10-030
2-4-2. Continuous water spray works, but intermittent water spray does not operate	10-032
2-5. Lighting	10-034
2-5-1. Head lamp, side marker lamp, tail lamp and license lamp do not light 1/2	10-034
2-5-1. Head lamp, side marker lamp, tail lamp and license lamp do not light 2/2	10-036
2-5-2. Flood lamp does not light 1/2	10-036
2-5-2. Flood lamp does not light 2/2	10-038

2-5-3. High-beam of head lamp does not light	10-038
2-5-4. Turn signal light does not blink	10-040
2-5-5. Hazard lamp does not light (Turn signal blinks)	10-042
2-5-6. Backup lamp does not light	10-044
2-5-7. Stop lamp does not light	10-044
2-5-8. Illumination of combination meter does not turn on	10-046
2-5-9. Combination meter warning lamp or indicator lamp is abnormal	10-046
2-5-10. Tachometer reading is abnormal	10-048
2-5-11. Hour meter is abnormal	10-048
2-5-12. Temperature meter is abnormal	10-050
2-5-13. Fuel meter is abnormal	10-050
2-5-14. Charge warning lamp remains ON	10-052
2-5-15. Oil pressure warning lamp remains ON	10-052
2-5-16. Parking brake indicator lamp does not light	10-054
2-5-17. Water spray indicator lamp does not light	10-056
2-5-18. Flood lamp indicator lamp does not light	10-058
2-5-19. Side marker lamp indicator lamp does not light	10-058
2-5-20. Turn signal indicator lamp does not light	10-060
2-5-21. Glow (Preheating plug) indicator lamp does not light	10-062
2-5-22. Horn does not sound	10-064
2-5-23. Backup buzzer does not sound	10-064
3. HYDRAULIC SYSTEM TROUBLESHOOTING	
3-1. When Performing Hydraulic System Troubleshooting	10-065
3-2. Propulsion System	10-066
3-2-1. Machine moves neither forward nor backward 1/2	10-066
3-2-1. Machine moves neither forward nor backward 2/2	10-067
3-2-2. Machine moves in one direction only (forward or backward)	10-067
3-2-3. Slow machine speed or small drive force 1/2	10-067
3-2-3. Slow machine speed or small drive force 2/2	10-068
3-2-4. Machine speed does not change	10-068
3-2-5. Machine does not stop completely with F-R lever in neutral	10-068
3-2-6. Propulsion system is overheating	10-069
3-2-7. Abnormal noise from propulsion system	10-069
3-3. Steering System	10-070
3-3-1. Steering wheel is hard to turn	10-070
3-3-2. Steering response is slow	10-070
3-3-3. Steering wheel backlash or play is large	10-071
3-3-4. Steering system is overheating	10-071
3-3-5. Abnormal noise from steering system	10-071

SAFETY

1. GENERAL SAFETY

1-1. Understanding the Safety Symbols and Words

The words DANGER, WARNING, and CAUTION are used with the safety-alert symbol. DANGER identifies the most serious hazard. When the symbols DANGER, WARNING and CAUTION are displayed, become alert. Your safety or those around you may be involved. NOTICE is used to provide important information that is not hazard related.

 **DANGER:** Indicates an imminently hazardous situation or condition which if not avoided can result in serious personal injury or death.

 **WARNING:** Indicates a potentially hazardous situation or condition which if not avoided can result in serious personal injury or death.

 **CAUTION:** Indicates a potentially hazardous situation or condition which if not avoided may result in moderate personal injury or damage to the machine or personal property.

(NOTICE): Indicates important information about operation or maintenance of the machine that may cause damage, breakdown, or shortened service life of the machine if you fail to observe or important point to maintain of quality in maintenance works.

★ : Indicates standard value to judge whether measured value is good or not.



Items that indicate the weight of a part or equipment and require attention in wire selection and operating posture for slinging operation.



In the assembly operation, tightening torque in locations that require particular attention.

1-2. General

- Operators and maintenance personnel must be alert to recognize and avoid potential hazards. They should also have comprehensive training, the required skills and necessary tools to perform the job safely.
- The machine was built in accordance to the latest safety standards and recognized safety rules. Nevertheless, misuse of the machine may result in risk to life and limb of the user or nearby personnel and may cause damage to the machine or other property.
- The machine must only be used for its intended purpose as described in the Operator's Manual. It must be operated by safety-conscious persons who are fully aware of the risks involved when operating the machine. Any malfunctions especially those affecting the safety of the machine must be corrected immediately.

- The machine is designed specifically for the compaction of asphalt or soil road construction materials. Use of the machine for other purposes such as towing other equipment is considered contrary to the designated use. The manufacturer cannot be responsible or held liable for any damage resulting from such use. The risk for such use lies entirely with the user.
- Operating the machine within the limits of its designated use also involves compliance with the inspection and maintenance requirements contained in the Operation and Maintenance Manual.

1-3. Qualifications of Operators and Maintenance Personnel

- Work on the machine must be performed by qualified personnel only. Individual responsibilities of personnel regarding operation, maintenance, repair of the machine must be clearly stated.
- Define the operator's responsibilities; the operator should have authority to refuse instructions that are contrary to safety.
- Do not allow persons being trained to operate or perform maintenance on the machine without constant supervision by an experienced person.
- Work on the electrical system of the machine must be done only by an experienced person or under the guidance of a skilled electrician and according to electrical engineering rules and regulations.
- Work on the frame, brakes, hydraulic and steering systems must be performed by skilled personnel with special knowledge and training for such work.

1-4. Safety Practices and Policies

- Keep the manuals in the container provided on the machine. Manuals must always be available at the site where the machine is being used.
- The operator or user of the machine must be aware of all applicable or legal and mandatory regulations relevant to accident prevention and environmental protection. These regulations may also deal with handling of hazardous substances, the required proper personal safety and protective equipment and traffic or jobsite regulations.
- Machine operating instructions should also be supplemented with detailed instructions pertaining to the specific jobsite or work location.
- Always be sure the persons working on the machine have read the operating instructions and all safety precautions before beginning work. Reading safety instructions after work has already begun is too late.
- Wear close fitting garments and always tie back and secure long hair, also avoid wearing jewelry such as rings. Injury can result from loose clothing, hair or jewelry being caught up in the machinery or rotating parts.
- Use protective equipment as required by the circumstances or by law.



- Observe all safety instructions and warnings attached to the machine.
- Make sure all safety instructions and warnings on the machine are complete and perfectly legible.
- Stop the machine immediately in the event of any malfunction. Report any malfunction immediately to the supervisor or other person of authority.
- Never perform service or maintenance on the machine unless the drums or tires are adequately blocked, articulation lock bar and pin is in the locked position and the parking brake is applied.
- Never make any modifications to the machine which might affect safety without the manufacturer's approval.
- Always perform the recommended routine inspections and adjustments according to the prescribed intervals.

1-5. Pre Start Inspection

- Inspect your machine daily. Ensure that the routine maintenance and lubrication are properly performed. Repair or replace any malfunctioning, broken or missing parts before using the machine. Refer to the maintenance schedule in the Operator's Manual.
- Check that all instructions and safety stickers are in place and readable.
- Never fill the fuel tank with the engine running or while near an open flame or while smoking.
- Always clean up any spilled fuel.
- Check for any warning tags placed on the machine, do not operate the machine until all repairs have been made and warning tags have been removed by authorized personnel.
- Check the seat belt for wear or damage; inspect the belt hardware and fabric. Replace if hardware is damaged or the belt is frayed or nicked or stitching is loose. Check that mounting hardware is tight.
- Clean the steps and operating platform of dirt and foreign matter to reduce danger of slipping.
- Know how to shut-down or stop the machine immediately in case of emergency.
- Know the capabilities and limitations of the machine such as speed, gradeability, steering and braking.
- Be aware of the dimensions of the machine such as height, weight especially for transporting.

1-6. Safety Instructions

- Take all necessary precautions to ensure that the machine is used only when in a safe and reliable condition.
- Avoid any operational mode that might compromise safety.
- Operate the machine only if all protective and safety devices are in place and fully functional.
- Always use the hand rails and steps to get on and off your machine maintaining 3-point contact (using both hands).

1-7. Starting

- Start the machine only from the driver's seat and always wear the seat belt.
- Watch that the warning lights and indicators during start-up and shutdown are working in accordance with operating instructions.
- Watch that no one is in danger before starting and when moving the machine.
- Check that braking, steering, signals and lights are fully functional before starting work or traveling with the machine.

1-8. Operating

- Always make sure that there are no obstructions or persons in your line of travel before starting the compactor in motion.
- Never climb on and off the machine while it is in motion.
- Always remain seated with the seat belt fastened when traveling, compacting or loading or unloading the machine.
- Use caution and be very observant when operating in close quarters and congested areas.
- Obey all traffic regulations when working on public roads and make sure machine is compatible with these regulations.
- Never carry passengers.
- Know and use the hand signals for particular jobs and who has the responsibility for signaling.
- Do not work close to edges or in the vicinity of overhanging banks or on grades that could cause the compactor to slide or roll over. Avoid any areas that may be a risk to machine stability.
- Avoid side hill travel. Always operate up and down the slope. Always keep the propulsion (travel control) lever in low speed range when climbing or descending hills or steep grades.
- Make sure there is sufficient clearance when crossing underpasses, bridges and tunnels or when passing under overhead power lines.
- Never allow anyone to stand in the articulation area of the machine when the engine is running.
- Always look in all directions before reversing the direction of travel.
- Always switch on the lighting system (if equipped) during poor visibility conditions and after dark.
- Do not attempt to control the compactor travel speed with the throttle control. Maintain engine speed at the full operating RPM.
- Do not run the engine in a closed building for an extended period of time. Exhaust fumes can kill.

1-9. Stopping

- Always park the machine in a safe area on solid and level ground. If this is not possible, always park at a right angle to the slope and block the drums or tires.
- Do not leave the operator's platform with the engine running. Always move the travel lever to neutral position and apply the parking brake then turn the starter switch to OFF.
- Lock all lockable compartments.

- Park behind a safe barrier, use proper flags, and warning devices, especially when parking in areas of heavy traffic.

1-10. Maintenance

- In any performing any work concerning the operation, adjustment or modification of the machine or it's safety devices or any work related to maintenance, inspection or repair, always follow the start-up and shut-down procedures in the Operator's Manual and the Maintenance Manual.
- Ensure that the maintenance area is safe and secure.
- If the machine is shut down for maintenance or repair work it must be secured against inadvertent starting by removing the starter key and attaching a warning sign to the starter switch.
- The machine must be parked on stable and level ground with the drums or tires blocked to prevent inadvertent movement.
- Immediately after the engine has stopped, the exhaust system, engine, radiator coolant, engine oil, hydraulic fluid and other lubricants and components will be very hot. Fluids can be under pressure, removing the radiator cap or draining oil or changing filters can cause serious burns. Wait until the machine has cooled down.
- Use care when attaching and securing lifting tackle to individual parts and large assemblies being removed or repositioned for repair purposes to avoid the risk of accident. Use lifting devices that are in perfect condition and of sufficient lifting capacity. Never stand under suspended loads.
- Always use the proper tools and workshop equipment in good condition when performing maintenance or repairs on the machine.
- Always use specially designed safety ladders and working platforms when working above floor level. Never use machine parts as a climbing aid.
- Keep all steps, handles, handrails, platforms and ladders free from mud, dirt, grease, ice or snow.
- Clean the machine, especially threaded connections of any traces of oil or fuel before carrying out any maintenance or repairs. Never use aggressive detergents. Use lint free cleaning rags.
- Examine all fuel, lubricant and hydraulic fluid lines and connectors for leaks, loose connections chafe marks or damage after cleaning.
- Repair or replace defective parts immediately.
- Whenever possible, avoid servicing or maintenance when the engine is running unless the drums or tires are adequately blocked, the articulation lock bar is in the locked position and the parking brake is applied.



SAFETY

- Never fill the fuel tank with the engine running, while near an open flame or while smoking. Always clean up any spilled fuel.
- Ensure safe operation, optimum performance of the machine and its warranty by using only genuine SAKAI replacement parts.
- Use only the specified fluids and lubricants. Substitute only products known to be equivalent from reputable manufacturers.
- Disconnect the battery cables when working on the electrical system or when welding on the compactor.
- Be sure the battery area is well ventilated (clear of fumes) should it be necessary to connect a jumper cable or battery charger. Fumes can ignite from a spark and may explode.
- Be sure battery charger is OFF when making connections if charging is required.
- Use only original fuses with the specified rating. Switch off the machine immediately if trouble occurs in the electrical system.
- Work on the electrical system may only be carried out by a qualified electrician or by a specially trained person according to electrical engineering principles.
- Inspect the electrical equipment of the machine at regular intervals. Defects such as loose connections or burnt or scorched wires must be repaired or replaced immediately.
- Do not weld, flame cut or perform grinding on the machine unless expressly authorized, as there may be a risk of fire or explosion. Disconnect the battery when welding on the machine.
- Clean the machine and its surrounding from dust or other flammable substances and make sure the area is adequately ventilated before beginning welding, flame cutting or grinding operations.
- Inspect hydraulic hoses at regular intervals and immediately replace if they show signs of chafing, cracking, brittleness, deformation, blistering, fitting separation, leakage, corrosion or other damage which may affect their function or strength.
- Do not work on hydraulic system while the engine is running and the system is under pressure. The hydraulic system remains pressurized even after the engine has stopped.
- Do not disconnect hydraulic hoses or fittings until the pressure has been properly relieved.
- Wait until the systems and fluid have cooled down before disconnecting.
- Never use your hands to check for leaks when inspecting a hydraulic system. Use a piece of cardboard and always wear gloves and safety glasses.



- Get immediate medical attention if fluid has been injected under your skin. Fluid penetration from a pin hole leak can cause severe injury or death.
- Ensure that hydraulic lines and hoses are routed and fitted properly. Ensure that no connections are interchanged. All fittings, lengths and specifications of hoses must comply with the technical requirements.

- Observe all product safety regulations when handling fuel, oils, grease, engine coolant and other chemical substances. Be careful especially when these items are hot as there is a risk of burning or scalding.
- Operate internal combustion engines and fuel operated heating systems only in adequately ventilated premises. Before starting the engine in an enclosed area, make sure there is sufficient ventilation.



1-11. Transporting the Machine

- Use only suitable and approved trailers and haul vehicles and lifting equipment of sufficient capacity.
- Entrust to experienced personnel the fastening and lifting of loads and instructing of crane operators.
- Only experienced persons familiar with the operation of the machine may load and unload the machine.
- Use ramps or a loading dock when loading or unloading the machine. Ramps must be the proper strength, low angle and the proper height and width.
- Block the drums or tires (front and rear) of the hauling vehicle when loading and unloading the compactor. Ensure that the haul vehicle is on level ground and approach the loading ramps squarely to make sure that the compactor does not slide off the edge of the ramp.
- Keep the deck clear of mud, oil, ice or snow or other materials that can make the deck slippery.
- Position the compactor on the trailer or transport vehicle centered from side to side, and apply the brake. Shut off the engine and lock all lockable compartments.
- Block the drums or tires and lock the articulation lock bar. Chain the machine down properly using the appropriate tackle.
- Know the overall height of the compactor and hauling vehicle. Observe height and weight regulations and be sure you can pass safely at overhead obstructions.
- Obey all traffic regulations and be sure that the proper clearance flags, lights and warning signs including "Slow Moving Vehicle" emblem are displayed when traveling on public roads.
- Know the approximate stopping distance at any given speed.
- Drive Safely. Never turn corners at excessive speeds.

SPECIFICATIONS

SPECIFICATIONS

1. SPECIFICATION DATA

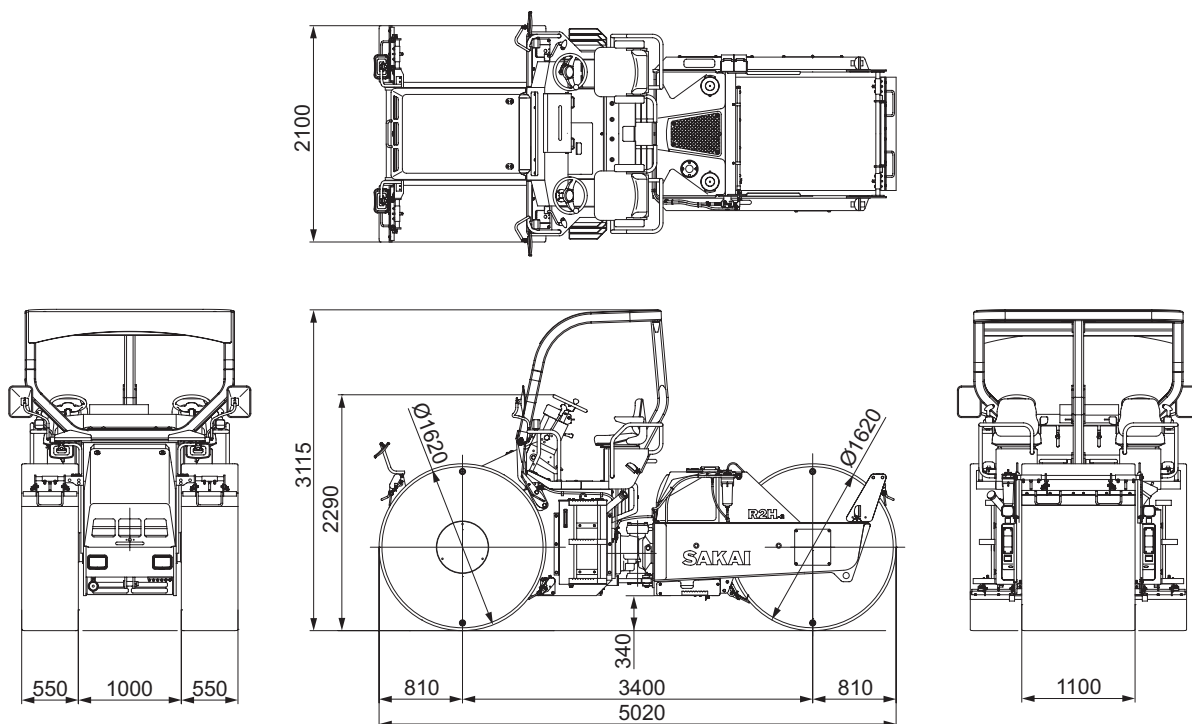

0634-99023-0-11132-0

Model		R2H-2		
Weight	Operating weight	14,345 kg	(31,625 lbs.)	
	Front axle	7,050 kg	(15,540 lbs.)	
	Rear axle	7,295 kg	(16,085 lbs.)	
Dimensions	Overall length	5,020 mm	(198 in.)	
	Overall width	2,100 mm	(83 in.)	
	Overall height	without ROPS	2,290 mm	(90 in.)
		with ROPS	3,115 mm	(123 in.)
	Wheelbase	3,400 mm	(134 in.)	
	Compaction width	2,100 mm	(83 in.)	
Minimum height above ground	340 mm	(13.5 in.)		
Speed	1st	0 to 8 km/h	(0 to 5.0 mph)	
	2nd	0 to 16 km/h	(0 to 9.9 mph)	
Minimum turning radius	6.3 m	(248 in.)		
Gradability *1	31 %	(17 °)		

*1 : The gradability is the calculated value. It may vary based on the ground surface conditions.

SPECIFICATIONS

Engine	Name		KUBOTA V3307-DI-T-KDN Diesel Engine with turbo charger (EPA Interim Tier4)		
	Model		Water-cooled, 4-cycle, 4-cylinder in-line, vertical mounted, overhead valve, direct-injection type		
	Number of cylinders - Bore × Stroke		4-94 mm × 120 mm (4-3.701 in. × 4.724 in.)		
	Displacement		3.331 L (203 cu.in)		
	Performance	Rated speed		2,200 min ⁻¹ (2,200 rpm)	
		Rated output (SAE J1995 JUN95)		55.4 kW (74 HP)	
		Max. torque (SAE J1995 JUN95)		265 N·m (195 lbf·ft) at 1,500 min ⁻¹	
		Fuel consumption (SAE J1995 JUN95)		239 g/kW·h (0.393 lb/HP·h) at rated speed	
	Governor		Mechanical all-speed type		
	Lubrication system		Pressure lubrication by gear pump		
	Oil filter		Full-flow : paper		
	Air cleaner		Dry type		
	Cooling system		Centrifugal pump forced feeding system		
	Cooling fan		Exhaling type		
	Electrical system	Alternator		12 V 80 A	
Starter		12 V 3.0 kW			
Battery		12 V 72 Ah × 1 pcs. (12 V)			
Power line	Transmission	Type	Hydrostatic transmission		
		Speed	2 speed shifts		
	Reverser	Switching the direction of flow delivered from the variable pump			
Final drive		Planetary gear			
Braking device	Service brake		Hydrostatic and mechanical multi-wet disc type		
	Parking brake		Mechanical multi-wet disc type		
Steering system	Steering control type		Hydraulic type (Articulated type)		
	Steering control angle		± 36 °		
	Oscillation angle		± 5.33 °		
Drums	Use	Front drum		Drive × 2	
		Rear drum		Drive × 1	
	Dimension	Front drum	width × diameter	550 mm × 1,620 mm (22 in. × 64 in.)	
		Rear drum	width × diameter	1,100 mm × 1,620 mm (43 in. × 64 in.)	
Ballast	Water ballast		3,180 kg (7,010 lbs)		
Water spray system		Pressurized type			
Others	Rops		Steel frame		
	Instruments & lights		1 set		

SPECIFICATIONS

2. TABLE OF STANDARD VALUES

2-1. Engine

Item		Standard value	Remarks
Engine model		KUBOTA V3307-DI-T-KDN Diesel Engine with turbo charger (EPA Interim Tier4)	
Rated output (SAE J1995 JUN95)		55.4/2,200 kW/min ⁻¹ (74/2,200 HP/rpm)	
Max. rpm under no load		2,400 ± 50 min ⁻¹ (2,400 ± 50 rpm)	
Min. rpm under no load		1,000 ± 50 min ⁻¹ (1,000 ± 50 rpm)	
Cylinder head tightening torque		187 to 196 N·m (138 to 145 lbf-ft)	
Intake manifold tightening torque		23.5 to 27.5 N·m (17.3 to 20.3 lbf-ft)	
Exhaust manifold tightening torque		23.5 to 27.5 N·m (17.3 to 20.3 lbf-ft)	
Fan belt tension		10 to 15 mm (0.39 to 0.59 in.)	When midpoint of belt pressed at 98 N (22 lbf)
Valve clearance (intake)		0.13 to 0.17 mm (0.005 to 0.007 in.)	
Valve clearance (exhaust)		0.13 to 0.17 mm (0.005 to 0.007 in.)	
Compression pressure	Standard	3.92 MPa (569 psi)	250 min ⁻¹ (rpm)
	Service limit	2.90 MPa (421 psi)	250 min ⁻¹ (rpm)
Injection pressure	1st stage	18.64 to 19.61 MPa (2,703 to 2,843 psi)	
	2nd stage	22.56 to 23.53 MPa (3,271 to 3,412 psi)	
Fuel consumption rate		239 g/kW·h (0.393 lb/HP·h)	
Engine dry weight		268 kg (591 lbs.)	

2-2. Propulsion

Item		Standard value	Remarks
Speed (Forward/reverse)	1st	0 to 8 km/h (0 to 5.0 mph)	
	2nd	0 to 16 km/h (0 to 9.9 mph)	

2-3. Hydraulic System

Item		Standard value	Remarks	
Propulsion	High pressure relief valve setting	41.8 ± 1.0 MPa (6,061 ± 145 psi)	At 1,800 min ⁻¹	
	Cut off valve setting	—	—	
	Charge relief valve setting	2.4 ± 0.2 MPa (348 ± 29 psi)		
	Case pressure	Pump	0.3 MPa (44 psi) or less	
		Front motor	0.3 MPa (44 psi) or less	
		Rear motor	0.3 MPa (44 psi) or less	
	Brake release pressure	Front motor	1.3 to 1.7 MPa (189 to 247 psi)	
		Rear motor	1.3 to 1.6 MPa (189 to 232 psi)	
		Rear axle	—	—
	Drainage	Front motor	4.8 L/min (1.3 gal./min)	
Rear motor		5.7 L/min (1.5 gal./min)		
Steering oil pressure		17.6 ± 1.0 MPa (2,552 ± 145 psi)	Orbitroll relief pressure + charge relief pressure	

2-4. Steering

Item	Standard value	Remarks
Play in steering wheel	5 to 10 mm (0.2 to 0.4 in.)	Steering wheel circumference
	0.5 mm (0.02 in.) or less	Steering column shaft direction
Steering chain tension	25 to 30 mm (1.0 to 1.2 in.)	When midpoint of chain at 19.6 N (4.4 lbf)

2-5. Brakes

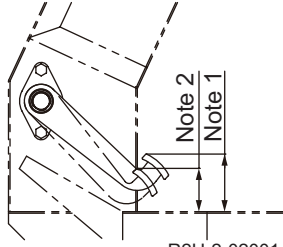
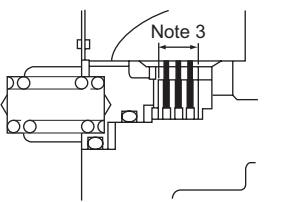
Item	Standard value	Remarks
Clearance between brake pedal and floorboard (as released)	120 mm (4.7 in.) Note 1 : See dimensions	 <p>R2H-2-02001</p>
Clearance between brake pedal and floorboard (when pressed down)	90 mm (3.5 in.) Note 2 : See dimensions	
Propulsion motor inner brake wear limit Thickness of disc assembly (7 discs)	18.5 to 19.1 mm (0.73 to 0.75 in.) Note 3 : See dimensions Allowable when thickness is within this range. Replace all 7 discs when thickness becomes 18.5 or less.	 <p>SW880-02002</p>

2-6. Capacities

Item	Standard value	Remarks
Engine oil pan	11.2 L (3.0 gal.)	
Fuel tank	100 L (26 gal.)	
Coolant	9.0 L (2.4 gal.)	
Gear box (front)	3.2 L × 2 (0.8 gal. × 2)	
Gear box (rear)	3.6 L (1.0 gal.)	
Hydraulic oil tank	85 L (22.5 gal.)	
Water spray tank	680 L (180 gal.)	

SPECIFICATIONS

3. FUEL AND LUBRICANTS SPECIFICATION

3-1. Rating

Lubricant	Service classification	Ambient temp. and applicable viscosity rating			Applicable Standards
		-15 to 30°C (5 to 86°F) Cold	0 to 40°C (32 to 104°F) Moderate	15 to 55°C (59 to 131°F) Tropical	
Engine oil	API grade CF	SAE10W-30	SAE30	SAE40	MIL-L-2104D
Gear oil	API grade GL4	SAE80W-90	SAE90	SAE140	MIL-L-2105
Hydraulic oil	Wear resisting	ISO-VG32 Over VI 140	ISO-VG46 Over VI 140	ISO-VG68 Over VI 110	ISO-3448
Grease	Lithium type extreme-pressure grease				NLGI-2
Fuel	Diesel oil				ASTM-D975-2D

3-2. Recommended Lubricants

Lubricant Oil company	Engine oil API CC	Gear oil API GL 4	Hydraulic oil VG 46	Grease (NLGI-II)
CALTEX	RPM DELO 300 oil	Universal Thuban 90	Rando Oil HD 46	Martifack EP 2
BP	BP Vanellus M30	BP Gear Oil EP 90	BP Energol HLP 46	BP Energrease LS-EP 2
ESSO	Esso Lube HDX 30	Esso Gear Oil GP 90	Nuto H 46	Beacon EP 2
MOBIL	Mobil Delvac 1230	Mobil Pegasus Gear Oil 90	Mobil DTE Oil 25	Mobil Lux EP 25
SHELL	Shell Rotella SX Oil 30	Shell Spirax 90 EP	Shell Tellus Oil 46	Shell Alvania EP Grease 2
CASTROL	Castrol CRB 30	Castrol Hypoy 90	Hyspin AWS 46	Spherrol ELP 2

4. TIGHTENING TORQUE CHART

N·m	(lbf·ft)
-----	----------

	Nominal Dia.	Pitch	Strength Classification							
			6.8		8.8		10.9		12.9	
Metric coarse screw	5	0.8	4.9	(3.6)	5.9	(4.4)	7.8	(5.8)	7.8	(5.8)
	6	1.0	7.8	(5.8)	9.8	(7.2)	13	(9.6)	13	(9.6)
	8	1.25	17	(13)	23	(17)	31	(23)	31	(23)
	10	1.5	39	(29)	49	(36)	59	(44)	59	(44)
	12	1.75	69	(51)	78	(58)	108	(80)	108	(80)
	14	2.0	98	(72)	127	(94)	167	(123)	167	(123)
	16	2.0	157	(116)	196	(145)	265	(195)	265	(195)
	18	2.5	196	(145)	245	(181)	343	(253)	343	(253)
	20	2.5	294	(217)	392	(289)	539	(398)	539	(398)
	22	2.5	441	(325)	539	(398)	686	(506)	686	(506)
	24	3.0	539	(398)	637	(470)	883	(651)	883	(651)
	27	3.0	785	(579)	981	(724)	1324	(977)	1324	(977)
	30	3.5	1079	(796)	1324	(977)	1765	(1302)	1765	(1302)
Metric fine screw	10	1.25	39	(29)	49	(36)	69	(51)	69	(51)
	12	1.25	69	(51)	88	(65)	118	(87)	118	(87)
	14	1.5	108	(80)	137	(101)	186	(137)	186	(137)
	16	1.5	167	(123)	206	(152)	284	(209)	284	(209)
	18	1.5	245	(181)	294	(217)	392	(289)	392	(289)
	20	1.5	343	(253)	441	(325)	588	(434)	588	(434)
	22	1.5	490	(361)	588	(434)	785	(579)	785	(579)
	24	2.0	588	(434)	735	(542)	981	(724)	981	(724)
	27	2.0	834	(615)	1030	(760)	1422	(1049)	1422	(1049)
	30	2.0	1177	(868)	1422	(1049)	1961	(1446)	1961	(1446)

ENGINE AND CONTROLS

1. ENGINE

1-1. Engine Mount

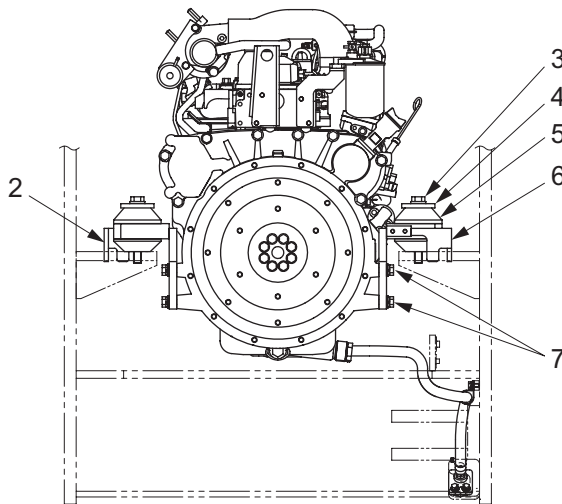
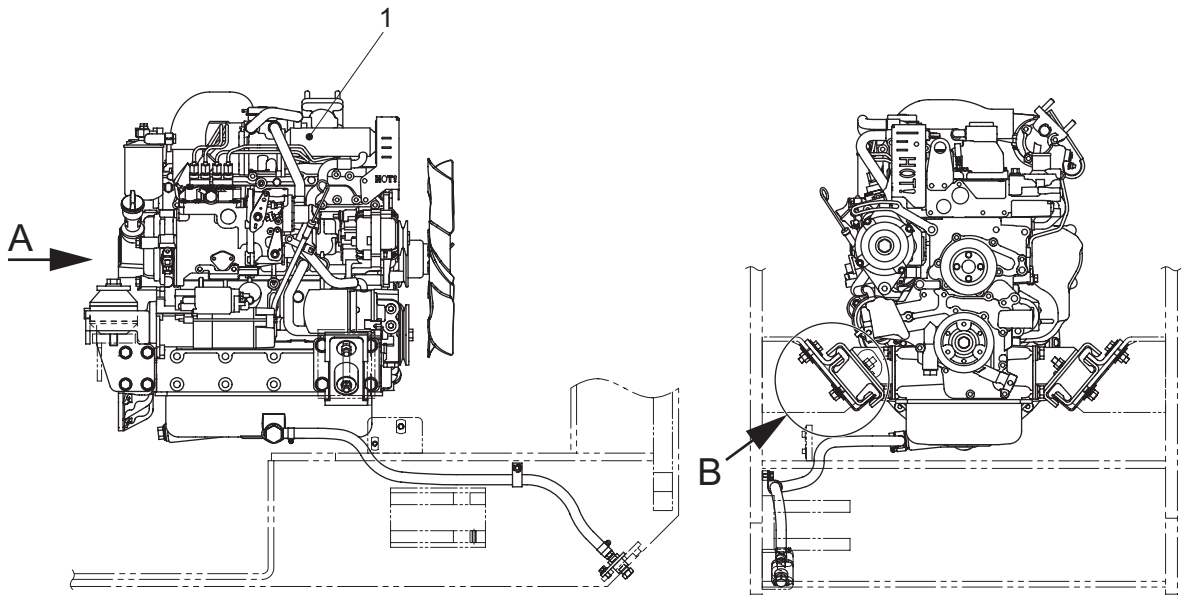

VIEW A

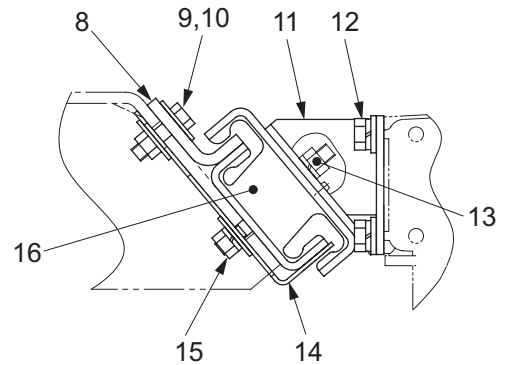

DETAIL B

0634-01806-0-11087-0

- | | | |
|--------------------|--------------------------|--------------------------|
| (1) Engine | (6) Bracket | (11) Bracket |
| (2) Bracket | (7) Bolt : M12×40 P=1.25 | (12) Bolt : M14×35 P=1.5 |
| (3) Bolt : M16×130 | (8) Stopper | (13) Nut : M12 P=1.25 |
| (4) Plate | (9) Bolt : M12×45 | (14) Stopper |
| (5) Damper | (10) Nut : M12 | (15) Nut : M12 P=1.25 |
| | | (16) Damper |



- | | | |
|------------------------|---|------------------------|
| (3) Bolt M16×130 | : | 265 N·m (195 lbf·ft) |
| (7) Bolt M12×40 P=1.25 | : | 118 N·m (87 lbf·ft) |
| (12) Bolt M14×35 P=1.5 | : | 186 N·m (137 lbf·ft) |
| (13) Nut M12 P=1.25 | : | 78 N·m (58 lbf·ft) |
| (15) Nut M12 P=1.25 | : | 78 N·m (58 lbf·ft) |

1-2. Engine Exterior

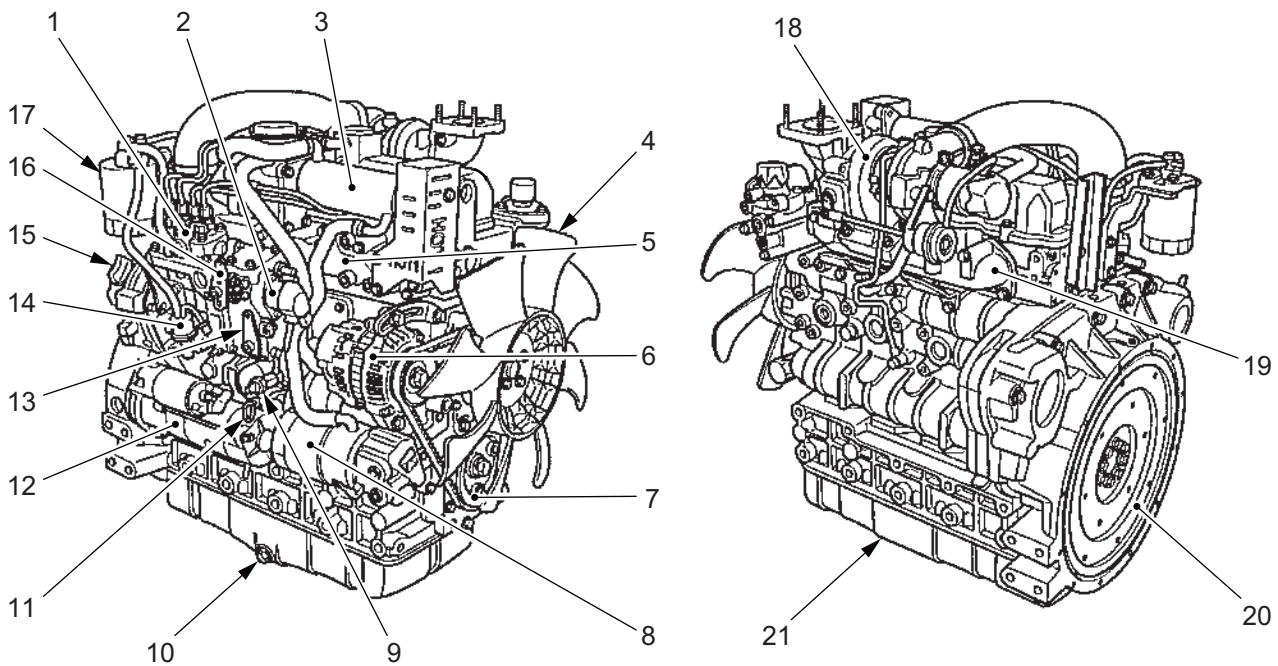

★ The actual equipment may differ from that shown above.

SW652-1-03001

- | | | |
|--------------------------|-------------------------|--------------------------|
| (1) Injection pump | (8) Engine oil filter | (15) Oil filler cap |
| (2) Engine stop solenoid | (9) Oil pressure switch | (16) Speed control lever |
| (3) EGR valve | (10) Oil drain plug | (17) Fuel filter |
| (4) Cooling fan | (11) Oil level gauge | (18) Turbocharger |
| (5) Intake manifold | (12) Starter motor | (19) Exhaust manifold |
| (6) Alternator | (13) Engine stop lever | (20) Flywheel |
| (7) Fan drive pulley | (14) Fuel supply pump | (21) Oil pan |

2. CONTROL SYSTEM

2-1. Throttle Control

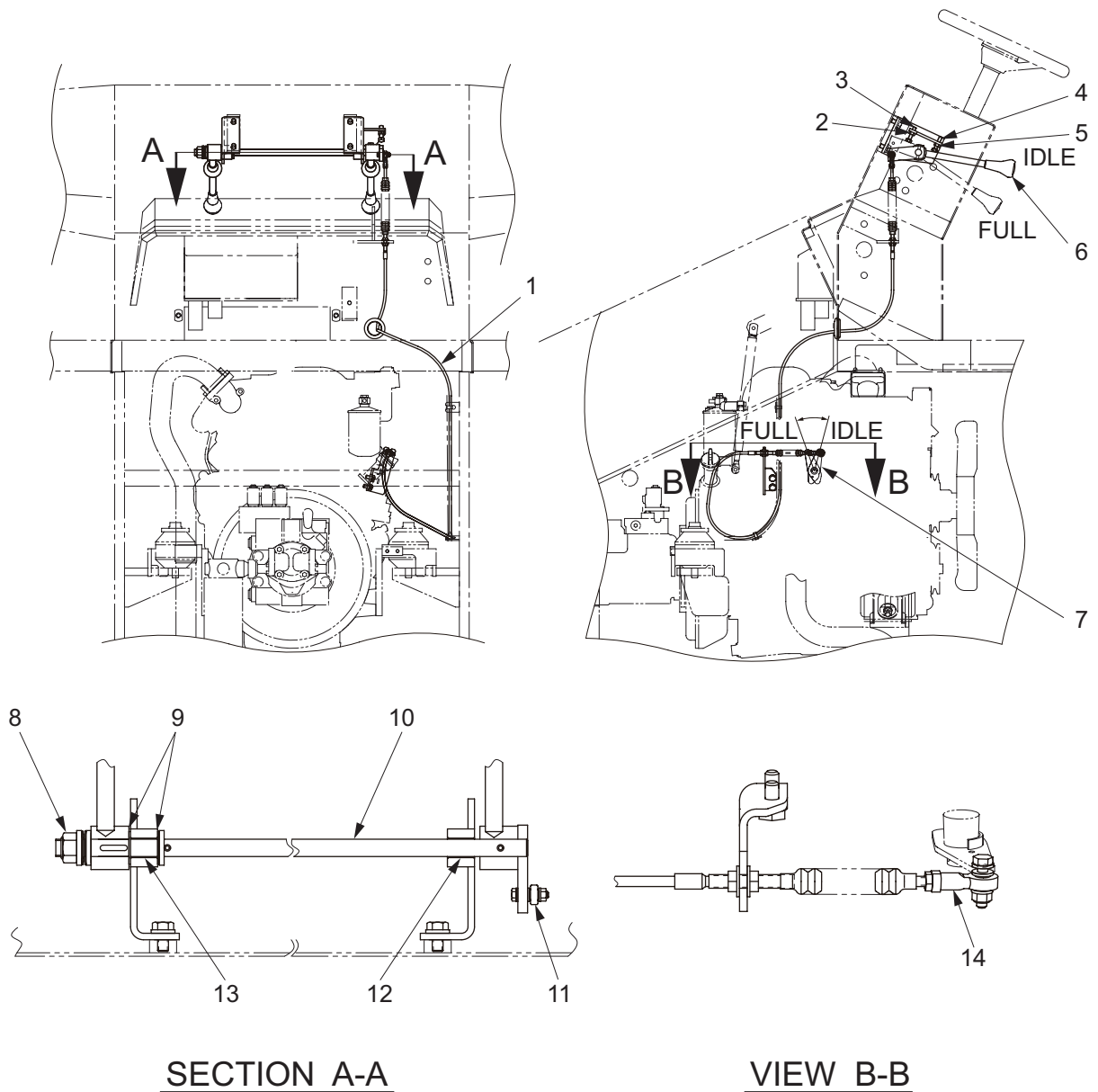

SECTION A-A

VIEW B-B

0634-12808-0-11079-A

- | | | | |
|-------------------------|---------|---|-------|
| (1) Control cable | | (8) Nut | : M16 |
| (2) Lock nut | : M8 | (9) Washer (Apply lithium-based grease) | |
| (3) Stopper bolt (FULL) | : M8×35 | (10) Shaft | |
| (4) Stopper bolt (IDLE) | : M8×35 | (11) Rod end (Apply lithium-based grease) | |
| (5) Lock nut | : M8 | (12) Bush (Apply lithium-based grease) | |
| (6) Throttle lever | | (13) Bush (Apply lithium-based grease) | |
| (7) Governor | | (14) Rod end (Apply lithium-based grease) | |

2-2. Forward-reverse Control

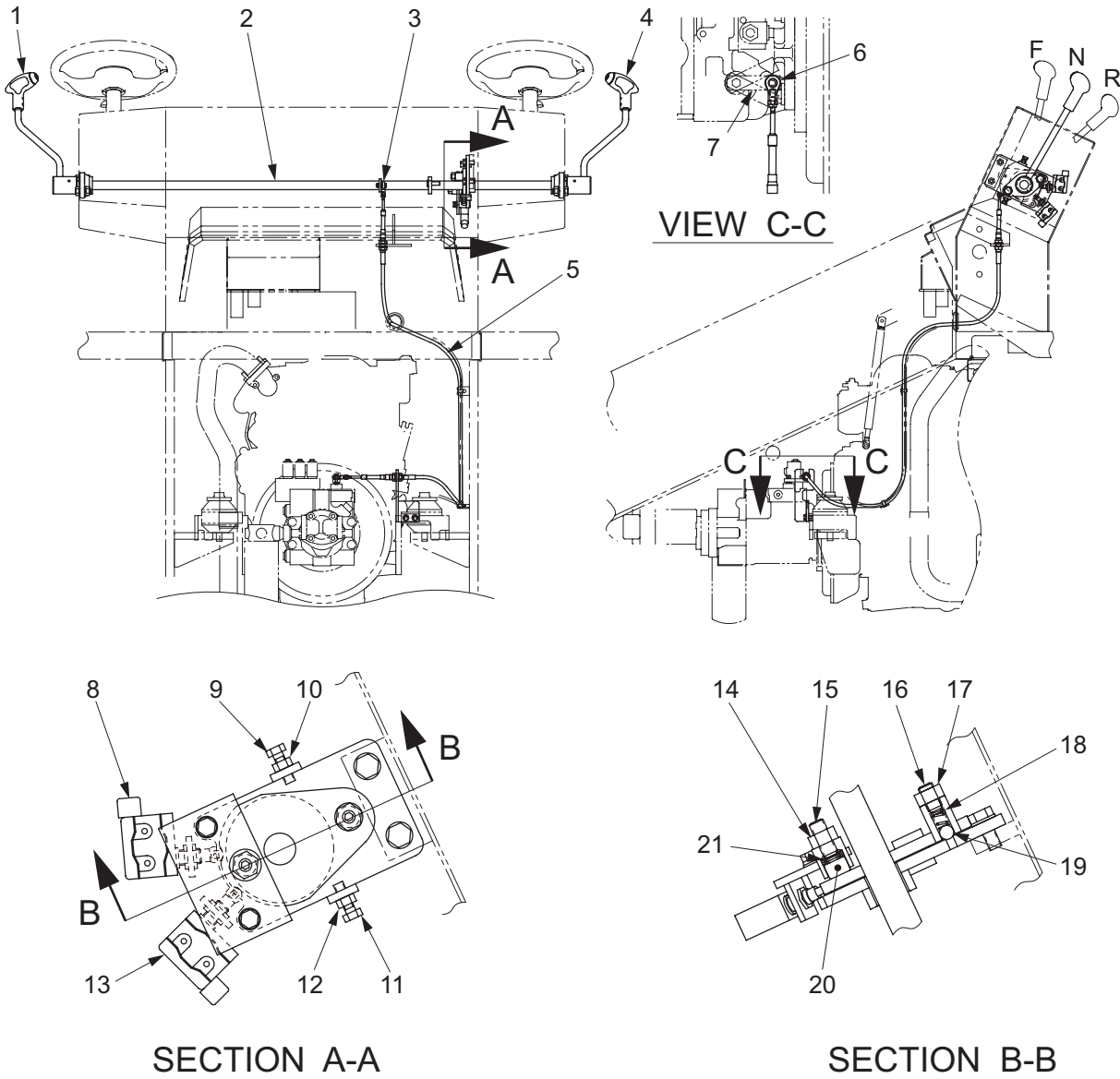

- | | | | |
|-----------------------|-------------------------------------|---------------------------------------|----------|
| (1) F-R lever (right) | (8) F-R lever switch | (15) Set screw | : M12×30 |
| (2) Shaft | (9) Stopper bolt (reverse) : M8×25 | (16) Set screw | : M12×30 |
| (3) Rod end | (10) Lock nut : M8 | (17) Lock nut | : M12 |
| (4) F-R lever (left) | (11) Stopper bolt (forward) : M8×25 | (18) Spring (Fill grease) | |
| (5) Control cable | (12) Lock nut : M8 | (19) Steel ball | |
| (6) Rod end | (13) Backup buzzer switch | (20) Holder | |
| (7) Pump lever | (14) Lock nut : M12 | (21) Coned disc spring (Apply grease) | |

0634-12809-0-11084-A

3. PUMP MOUNT

3-1. Pump Mount

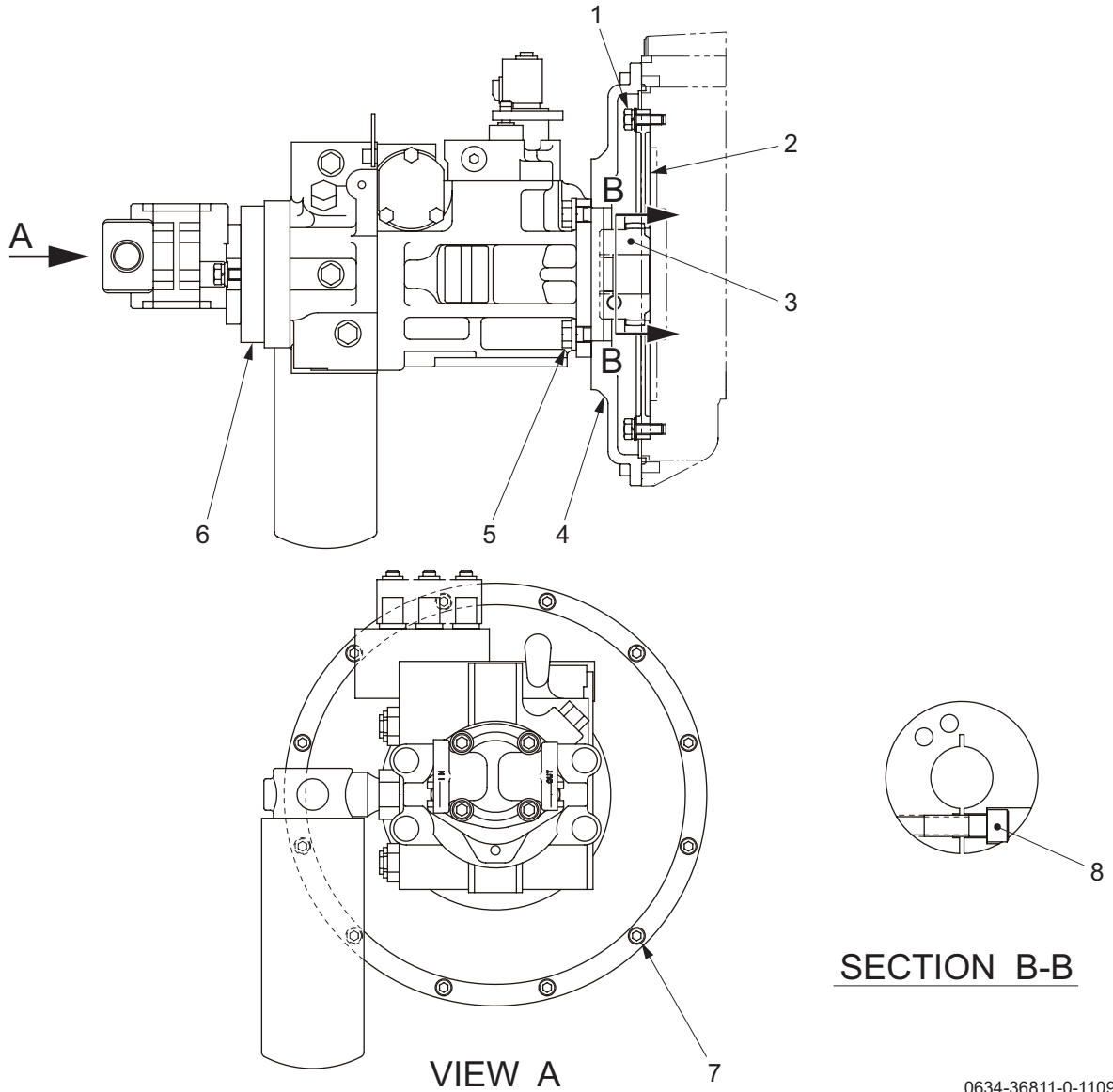

- | | | | |
|-------------|-----------------|----------|-----------------|
| (1) Bolt | : M10×30 P=1.25 | (5) Bolt | : M14×40 |
| (2) Flange | | (6) Pump | |
| (3) Hub | | (7) Bolt | : M10×20 P=1.25 |
| (4) Housing | | (8) Bolt | : M12×35 |



- | | | | | |
|-----------------|--------|---|---------|----------------|
| (1) Bolt M10×30 | P=1.25 | : | 49 N·m | (36 lbf·ft) |
| (5) Bolt M14×40 | | : | 167 N·m | (123 lbf·ft) |
| (7) Bolt M10×20 | P=1.25 | : | 69 N·m | (51 lbf·ft) |
| (8) Bolt M12×35 | | : | 86 N·m | (63 lbf·ft) |

0634-36811-0-11098-0

3-1-1. Installation of pump

- When the pump assembly has been removed from the engine for repair or replacement, reinstall it in accordance with the following procedure.

- ① Apply adequate amount of lithium-based grease to pump (6) and hub (3) splines.
- ② Install hub (3) to pump (6) aligning it with end surface of pump shaft.

- ③ Tighten bolt (8) to secure hub (3).

 (8) Bolt M12×35 : 86 N·m (63 lbf-ft)

- ④ Install housing (4) to pump (6) and tighten with four bolts (5) and washers.

 (5) Bolt M14×40 : 167 N·m (123 lbf-ft)

- ⑤ Install flange (2) to engine flywheel and tighten eight bolts (1) and spring washers, and washers.

 (1) Bolt M10×30 P=1.25 : 49 N·m (36 lbf-ft)

- ⑥ Ensure engagement of flange (2) with hub (3) and install pump subassembly to engine.

- ⑦ Tighten with twelve bolts (7).

 (7) Bolt M10×20 P=1.25 : 69 N·m (51 lbf-ft).

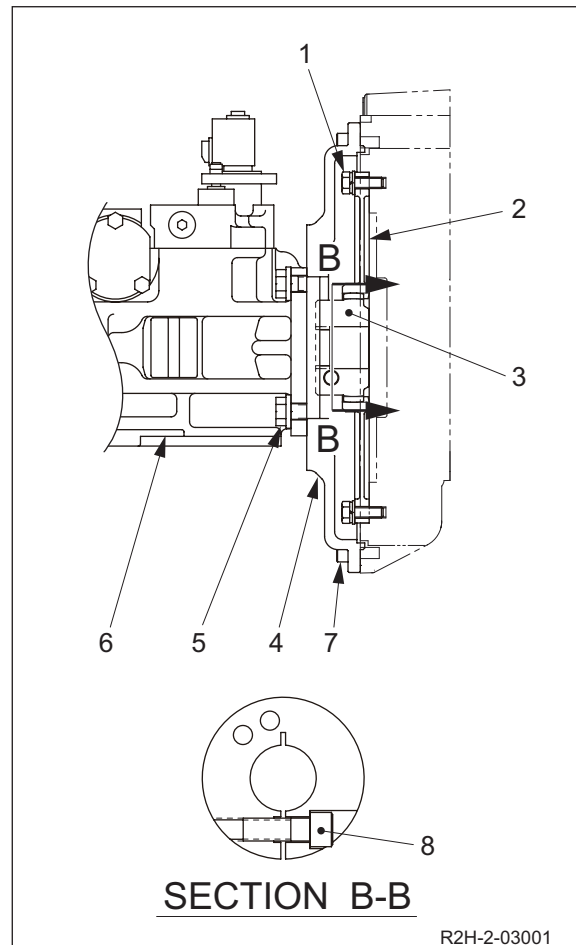

(NOTICE)

- Bolts (1) and (7) are treated with thread-locking fluid.
When removed, replace with new bolts.

HYDRAULIC SYSTEMS

1. SYSTEM CIRCUIT DIAGRAM

1-1. Graphic Symbols for Hydraulic Circuits





Basic Symbols

DESCRIPTION	SYMBOL
Lines:	
Main working	
Pilot control	
Drain or bleed	
Lines, joining	
Not connected	
Component outline	
Arrow indicates direction of flow.	
Line with fixed restriction (orifice).	
Test port, pressure measurement.	
Temperature measurement gauge	
Pressure measurement gauge	
Reservoir (vented)	
Filter or strainer	
Heat exchanger, lines indicate flow of coolant.	
Quick disconnect: Connected with mechanically opened checks.	
Disconnected.	
Sloping arrow through a symbol at 45° indicates that a component can be adjusted or varied.	



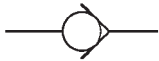

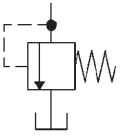

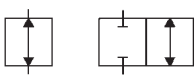
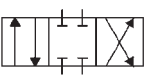
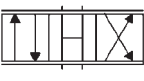

Pump, Motors and Cylinders

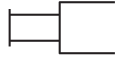
DESCRIPTION	SYMBOL
Hydraulic pumps:	
Fixed displacement	
Unidirectional	
Bidirectional	
Variable displacement	
Unidirectional	
Bidirectional	
Variable displacement pressure compensated Unidirectional	
Hydraulic Motor:	
Unidirectional	
Bidirectional	
Double acting hydraulic cylinder	
Differential cylinder	
Electric motor	

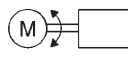
Valves

DESCRIPTION	SYMBOL
Check valve	
Manual shut off (On-Off)	
Pressure relief	
Flow control, adjustable	
Valve symbols: The basic valve symbol one or more squares with lines representing flow paths and flow conditions between ports.	
Multiple squares indicate a valve with as many distinct positions there are squares providing various flow path options for the fluid. The multiple square moves to represent how flow paths change when the valving element is shifted within the component.	
Valves with infinite positioning between certain limits are symbolized with lines parallel to the squares.	

Methods of Operation

DESCRIPTION	SYMBOL
Spring	
Manual	
Pressure compensated	
Reversing motor	
Pilot pressure: Internal supply	
Remote supply	
Solenoid: Single winding	
Two windings operating in opposite directions.	
Pilot directional valve is actuated by the solenoid.	

1-2. Hydraulic Circuit Diagram

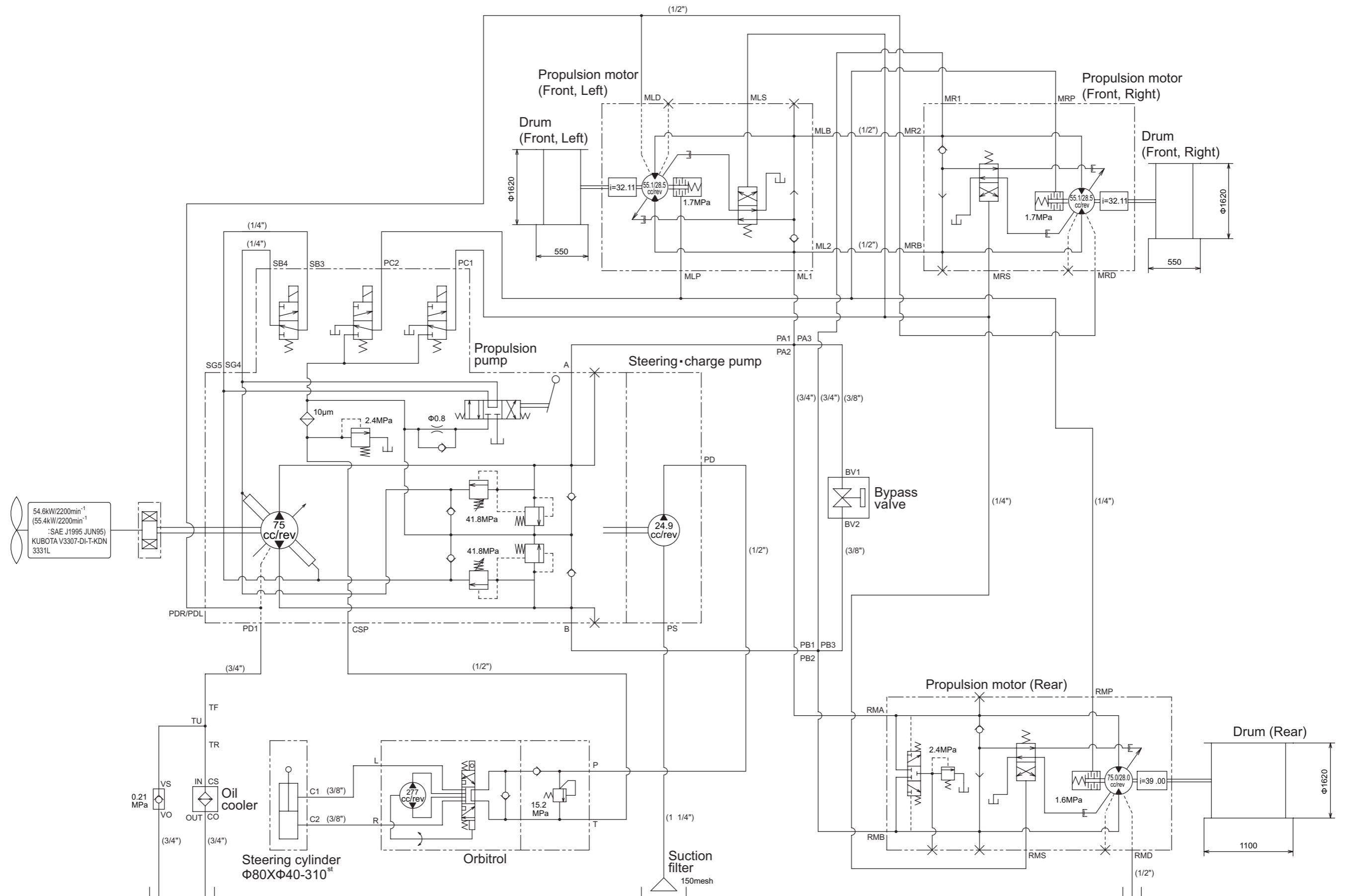

2. PROPULSION HYDRAULIC SYSTEM

2-1. Propulsion Hydraulic Piping

2-1-1. Propulsion hydraulic piping (Front 1)

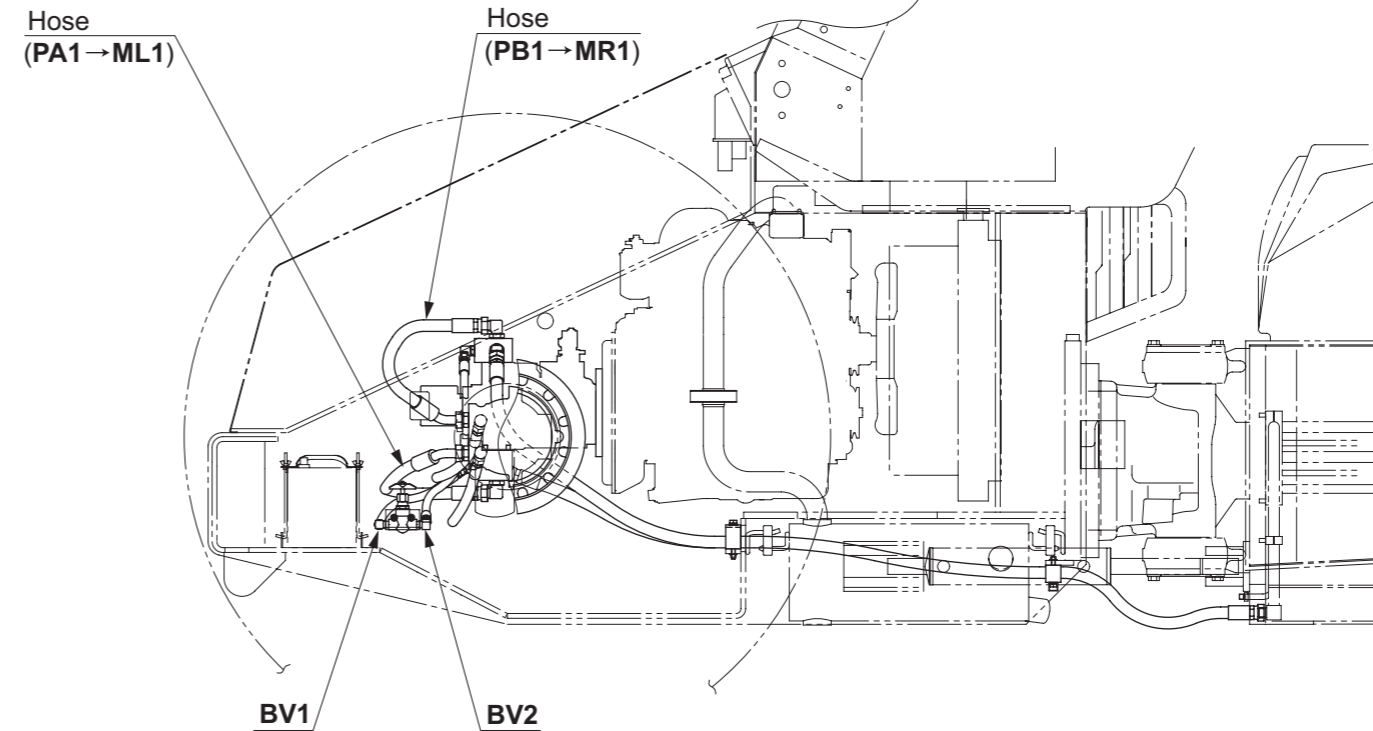
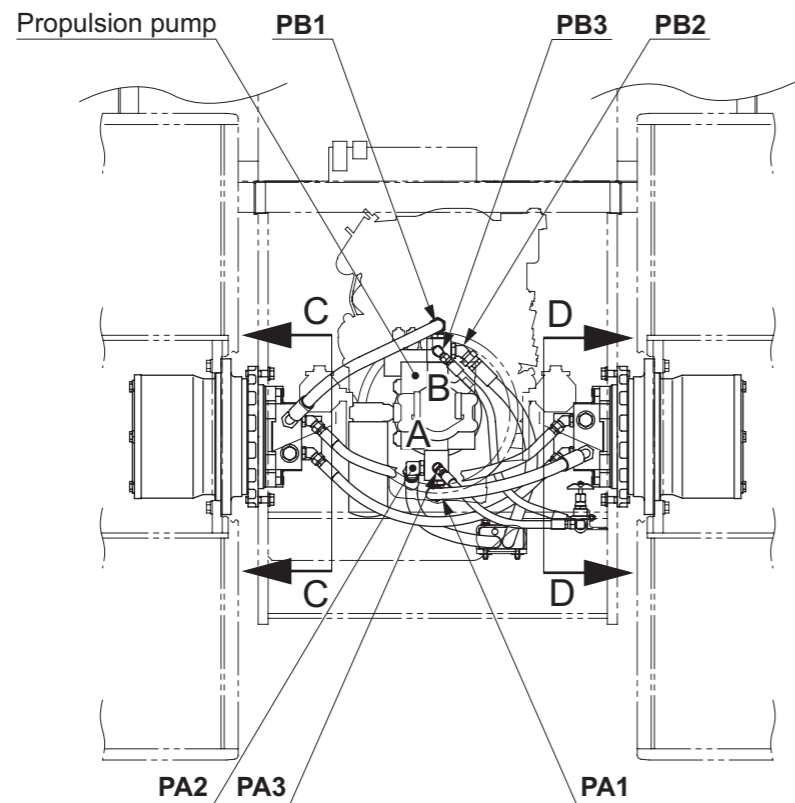
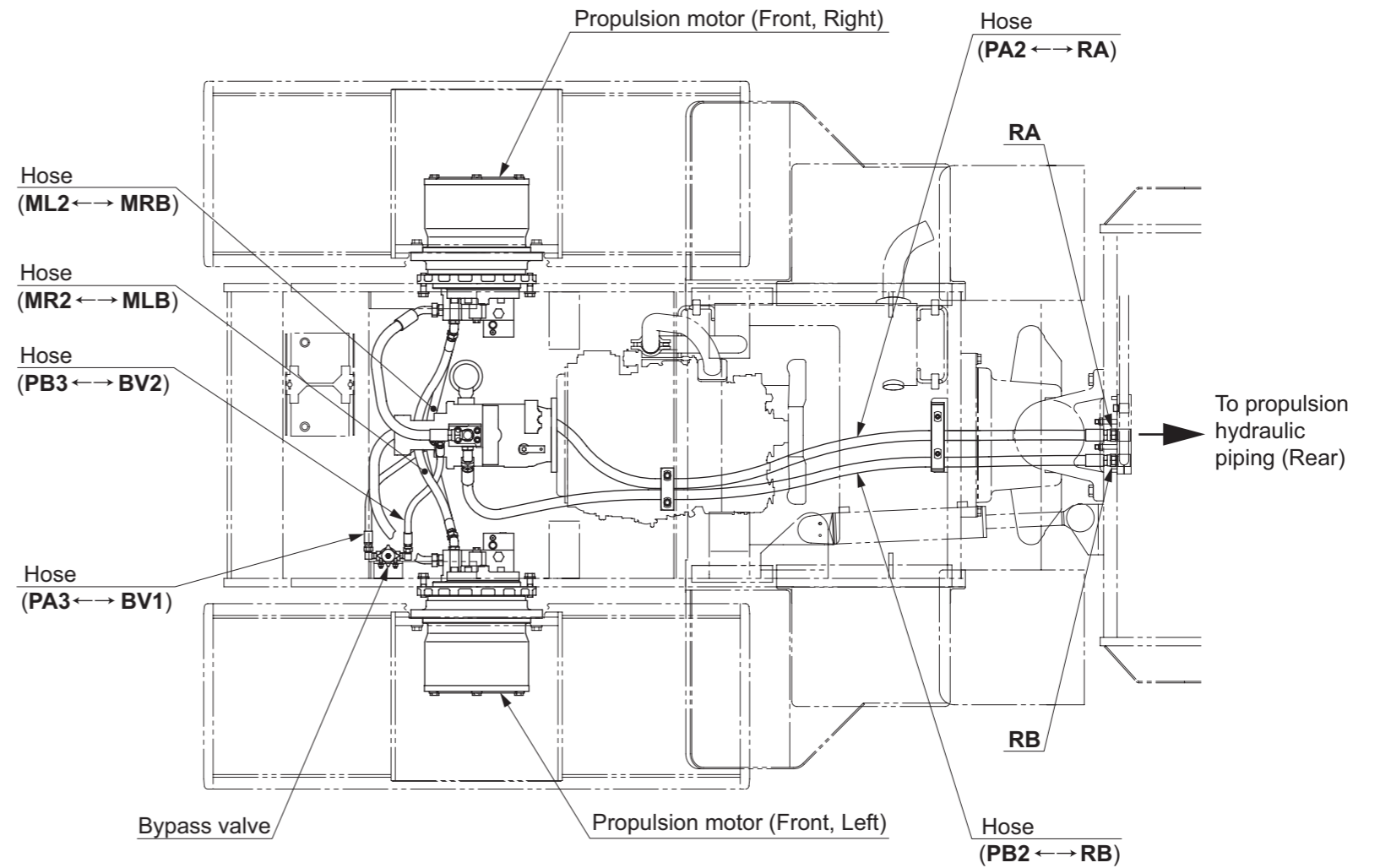
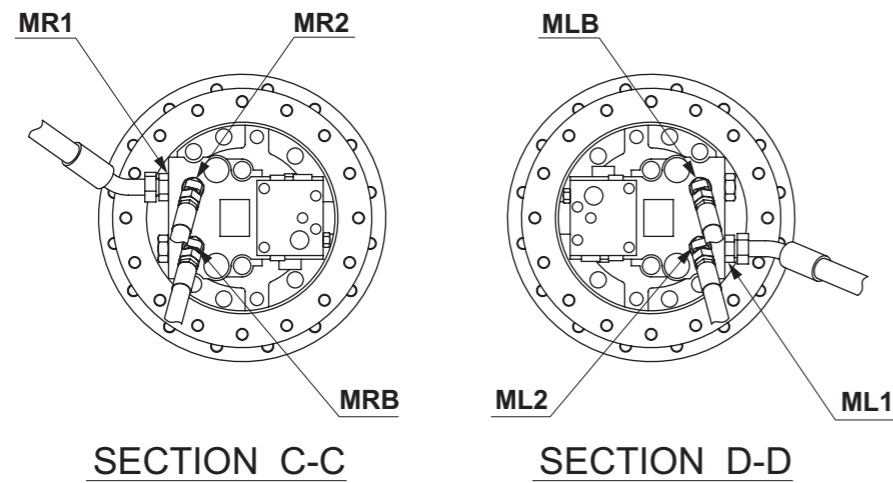

• The letters and figures (such as PB1 and MR1) show each port and the arrow (↔; →) symbols show the hose connection and the direction of the flow of the oil.

2-1-2. Propulsion hydraulic piping (Front 2)

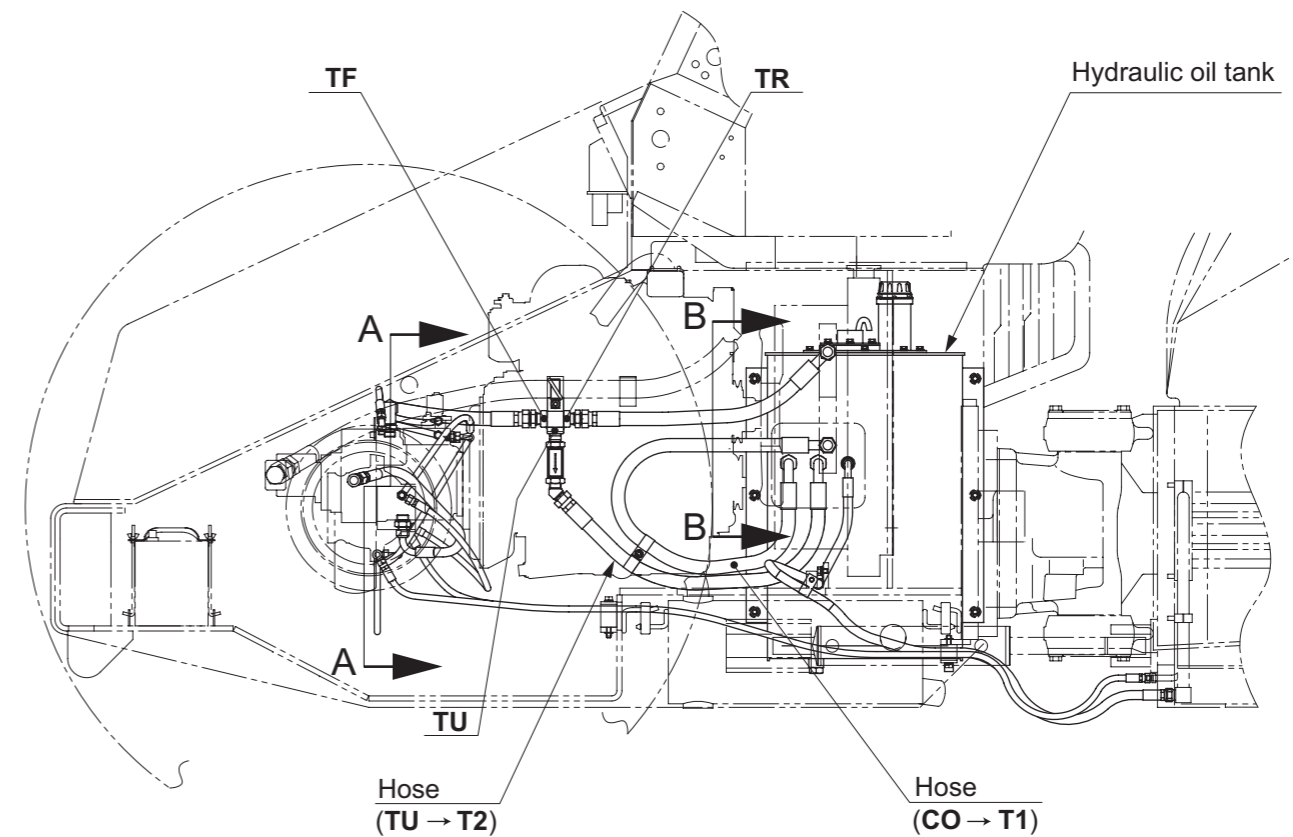
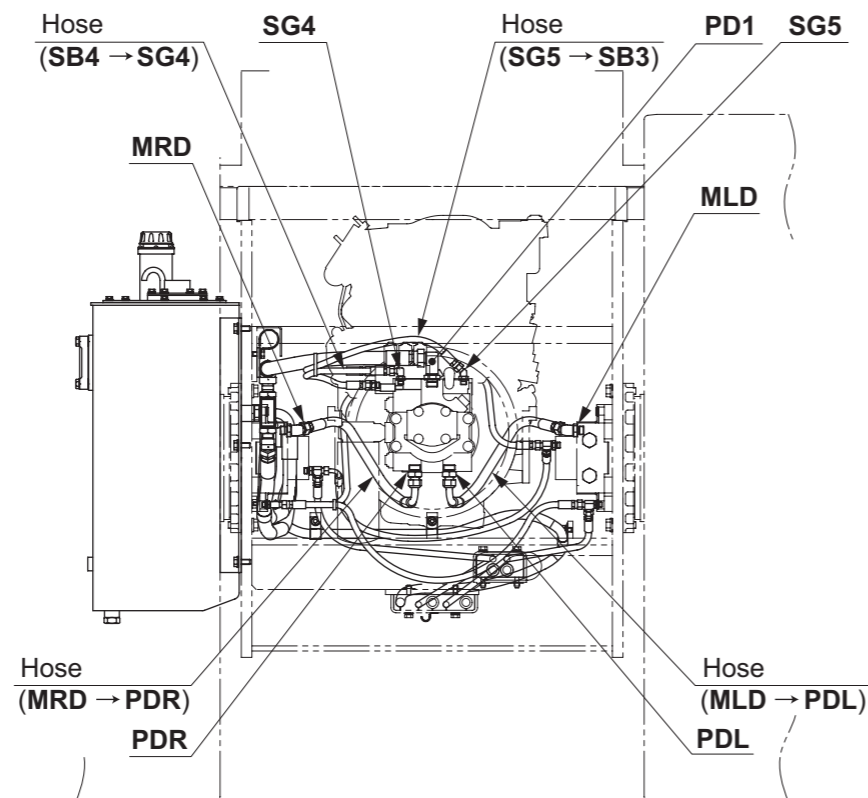
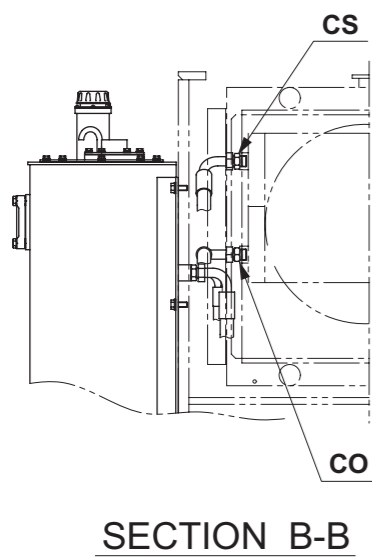
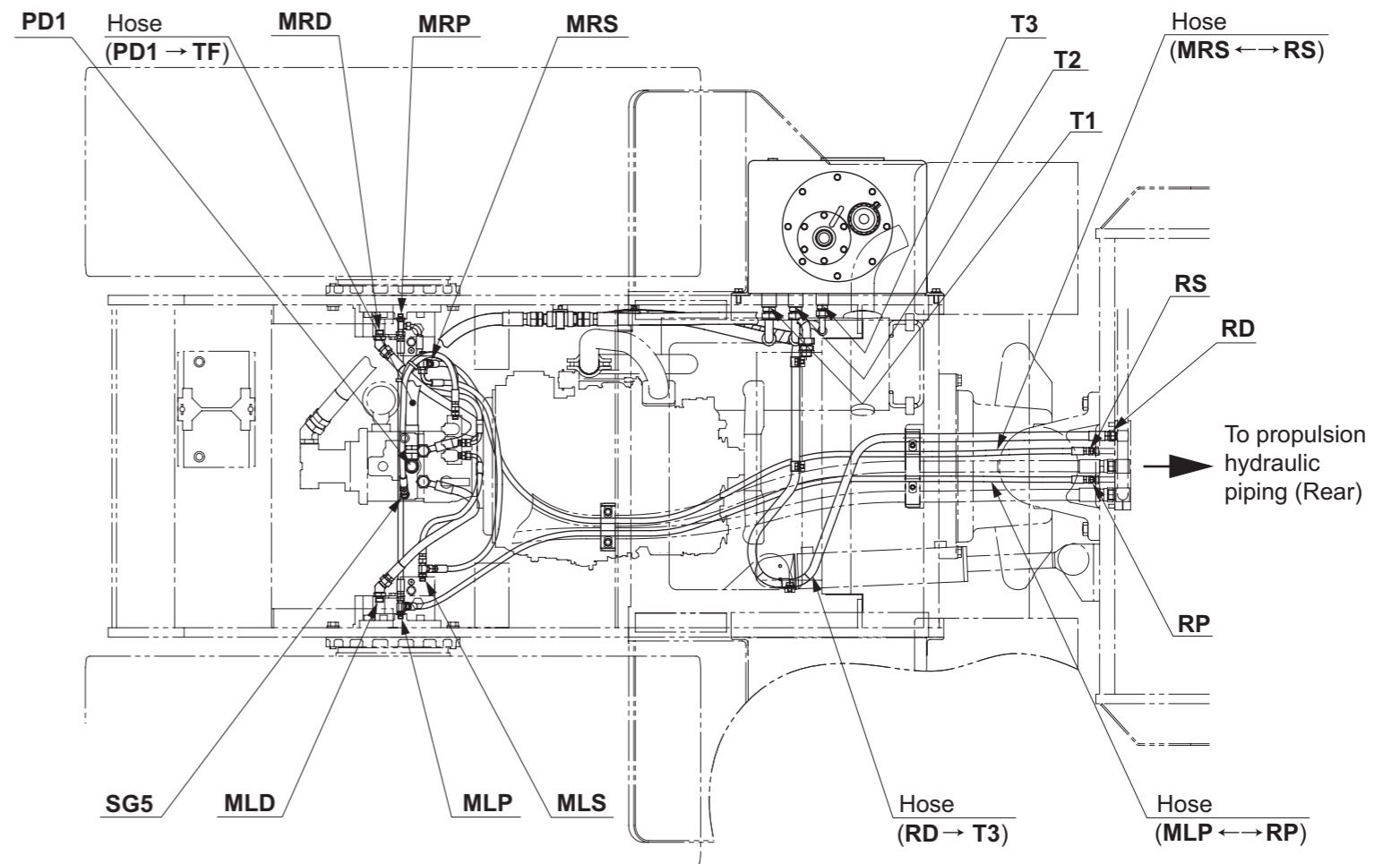
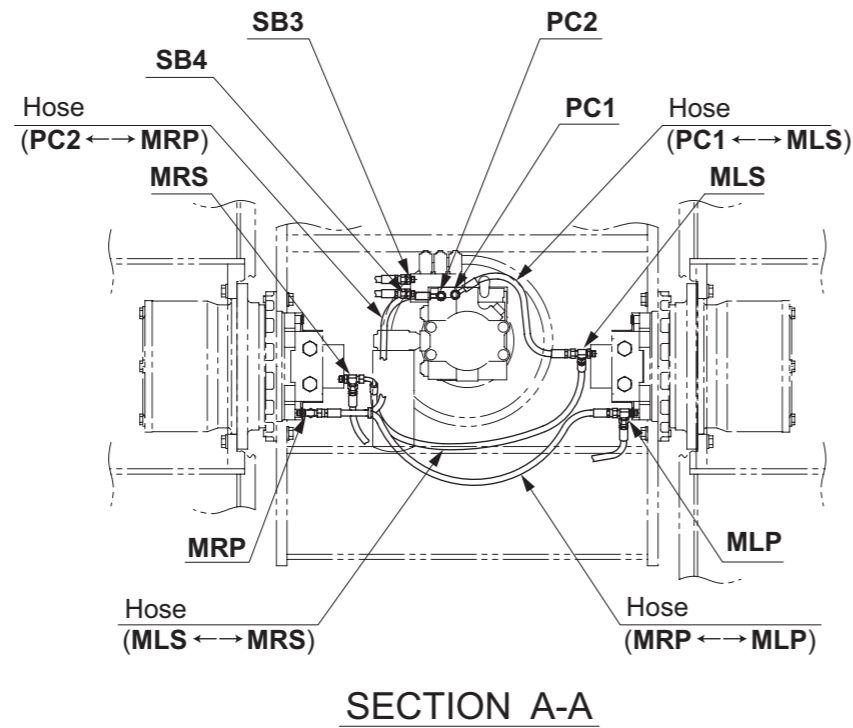

• The letters and figures (such as TU and T2) show each port and the arrow (↔; →) symbols show the hose connection and the direction of the flow of the oil.

2-1-3. Propulsion hydraulic piping (Rear)

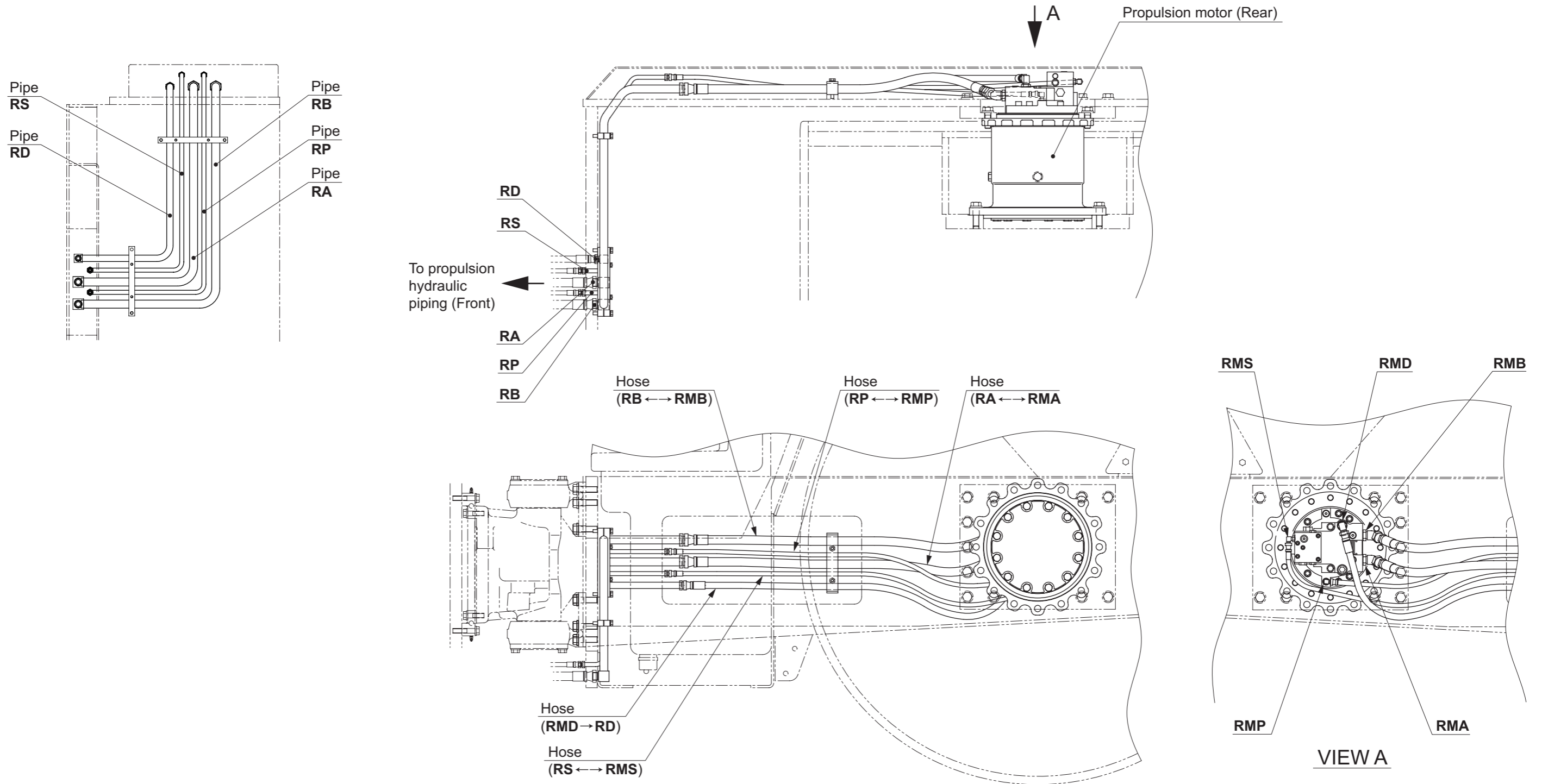

• The letters and figures (such as RMB and RB) show each port and the arrow (↔; →) symbols show the hose connection and the direction of the flow of the oil.

2-2. Hydraulic Component Specifications

2-2-1. Hydraulic pump assembly (propulsion + steering · charge)

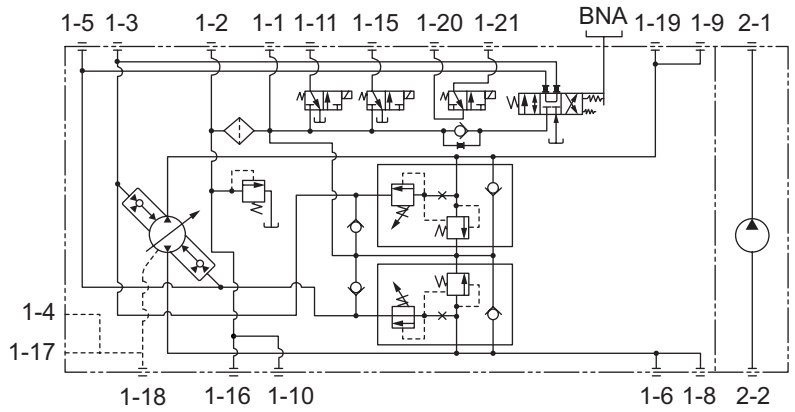
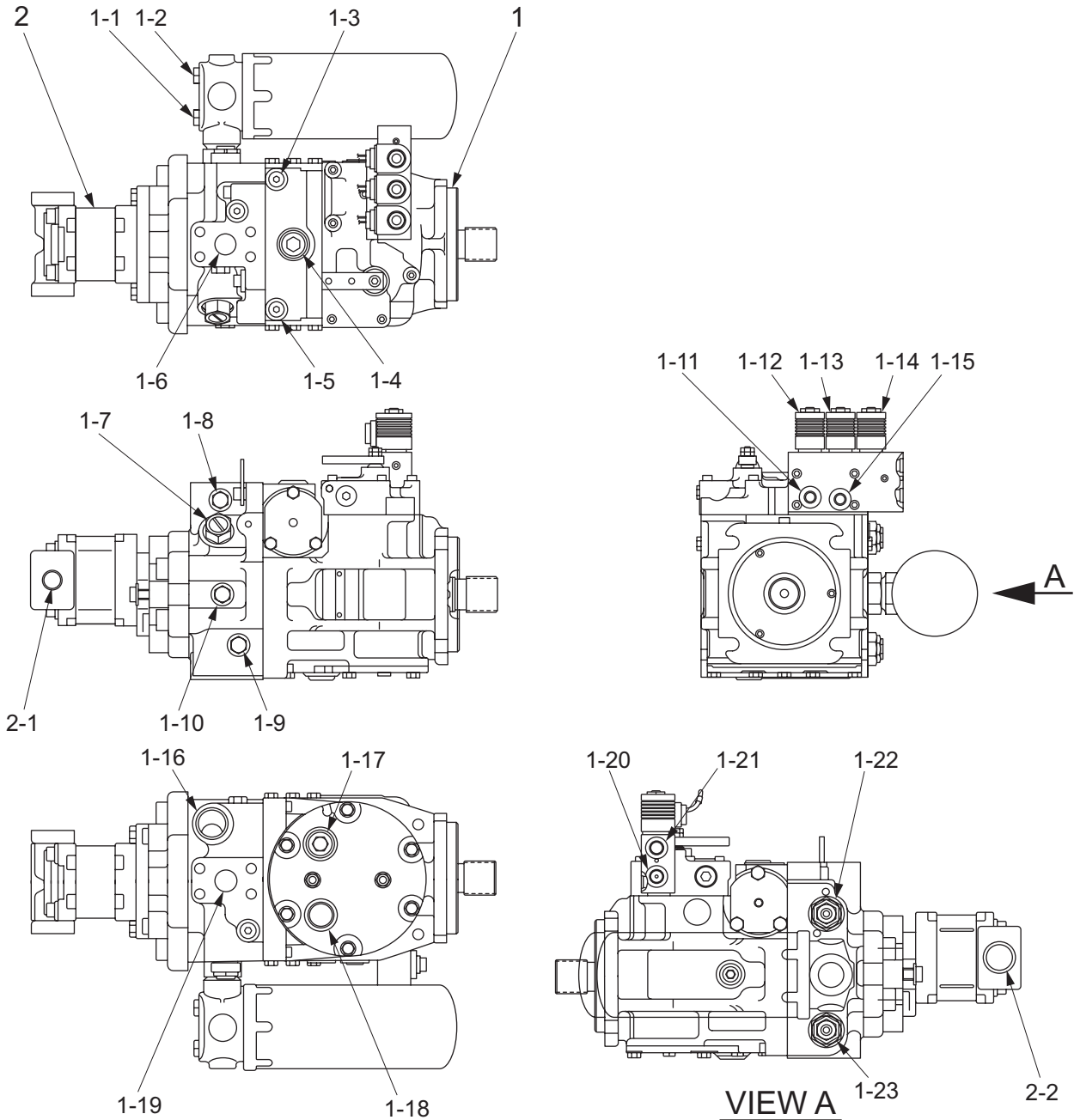

Pump circuit diagram

(1) Propulsion pump

(1-1) Charge pressure gauge port (After oil filter)	:	9/16-18UNF
(1-2) Charge pressure gauge port (Before oil filter)	:	9/16-18UNF
(1-3) Servo pressure gauge port	[SG4]	: 9/16-18UNF
(1-4) Drain port	[PD1]	: 1 1/16-12UN
(1-5) Servo pressure gauge port	[SG5]	: 9/16-18UNF
(1-6) Port B (Reverse)	[B]	: SAE 1"
(1-7) Charge relief valve		
(1-8) High pressure gauge port (For Port B)	:	9/16-18UNF
(1-9) High pressure gauge port (For Port A)	:	9/16-18UNF
(1-10) Charge gauge port	:	9/16-18UNF
(1-11) Pilot charge pressure port	[PC1]	: 9/16-18UNF
(1-12) Speed change solenoid		
(1-13) Parking brake solenoid		
(1-14) Servo bypass solenoid		
(1-15) Pilot charge pressure port	[PC2]	: 9/16-18UNF
(1-16) Charge supply port	[CSP]	: 1 5/16-12UN
(1-17) Drain port	[PDL]	: 1 1/16-12UN
(1-18) Drain port	[PDR]	: 1 1/16-12UN
(1-19) Port A (Forward)	[A]	: SAE 1"
(1-20) Servo bypass solenoid port	[SB4]	: 9/16-18UNF
(1-21) Servo bypass solenoid port	[SB3]	: 9/16-18UNF
(1-22) Multi function valve (Port B)		
(1-23) Multi function valve (Port A)		

Specifications

• Displacement	:	75 cm ³ /rev (4.58 cu.in./rev)
• Pressure limit pressure setting	:	41.8 MPa (6,061 psi) (at 1,800 min ⁻¹)
• Charge relief valve pressure setting	:	2.4 MPa (348 psi) (at 1,800 min ⁻¹)

(2) Steering • Charge pump

(2-1) Discharge port	[PD]	: G3/4
(2-2) Suction port	[PS]	: G1

Specifications

• Displacement	:	24.9 cm ³ /rev (1.52 cu.in./rev)
• Allowable pump case pressure	:	0.3 MPa (43.5 psi) or less
• Pump assembly weight	:	60 kg (132 lbs.)

2-2-2. Propulsion hydraulic motor (front)

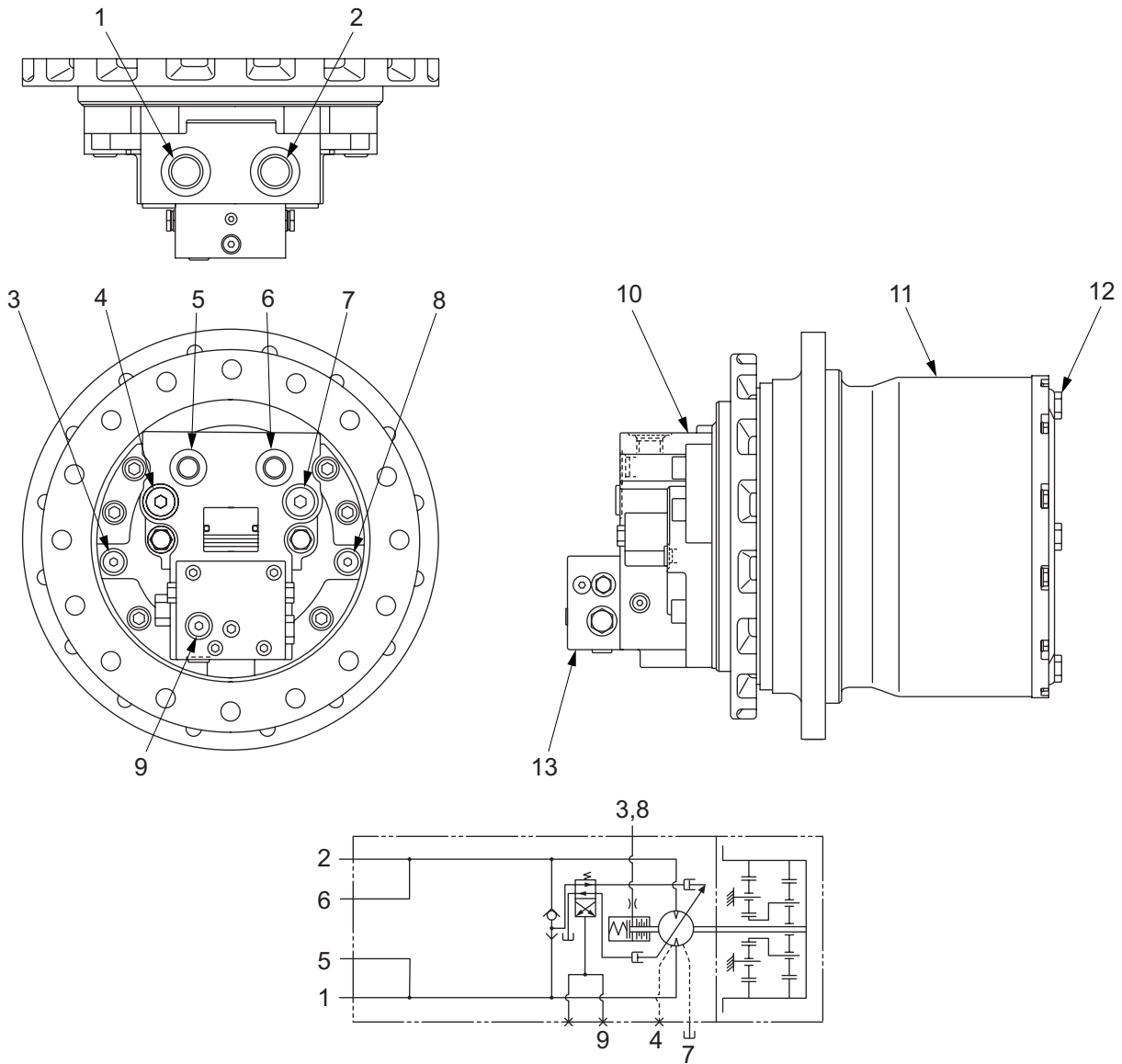

Motor circuit diagram

R2H-2-04002

- | | | | | | | |
|------------------------------|--------------------|------|------------------------------|--------------------|---|------------|
| (1) Port B1 | : | G3/4 | (8) Parking brake pilot port | [MLP] | : | G1/4 |
| (2) Port A1 | [ML1] [MR1] | G3/4 | (9) Speed change port | [MLS] [MRS] | : | 9/16-18UNF |
| (3) Parking brake pilot port | [MRP] | G1/4 | (10) Motor | | | |
| (4) Drain port | [MLD] | G1/2 | (11) Reduction gear | | | |
| (5) Port B2 | [MLB] [MRB] | G1/2 | (12) Filler cap | | : | PF 3/8 |
| (6) Port A2 | [ML2] [MR2] | G1/2 | (13) Shift valve assembly | | | |
| (7) Drain port | [MRD] | G1/2 | | | | |

Motor specifications

- Displacement (max.) : 55.1 cm³/rev (3.36 cu.in./rev)
- (min.) : 28.5 cm³/rev (1.74 cu.in./rev)
- Brake release pressure : 1.3 to 1.7 MPa (189 to 247 psi)
- Allowable motor case pressure : 0.3 MPa (44 psi) or less

Reduction gear specifications

- Reduction ratio : 1:32.11
- Weight : 162 kg (357 lbs.)

1) Internal structure of propulsion hydraulic motor (front)

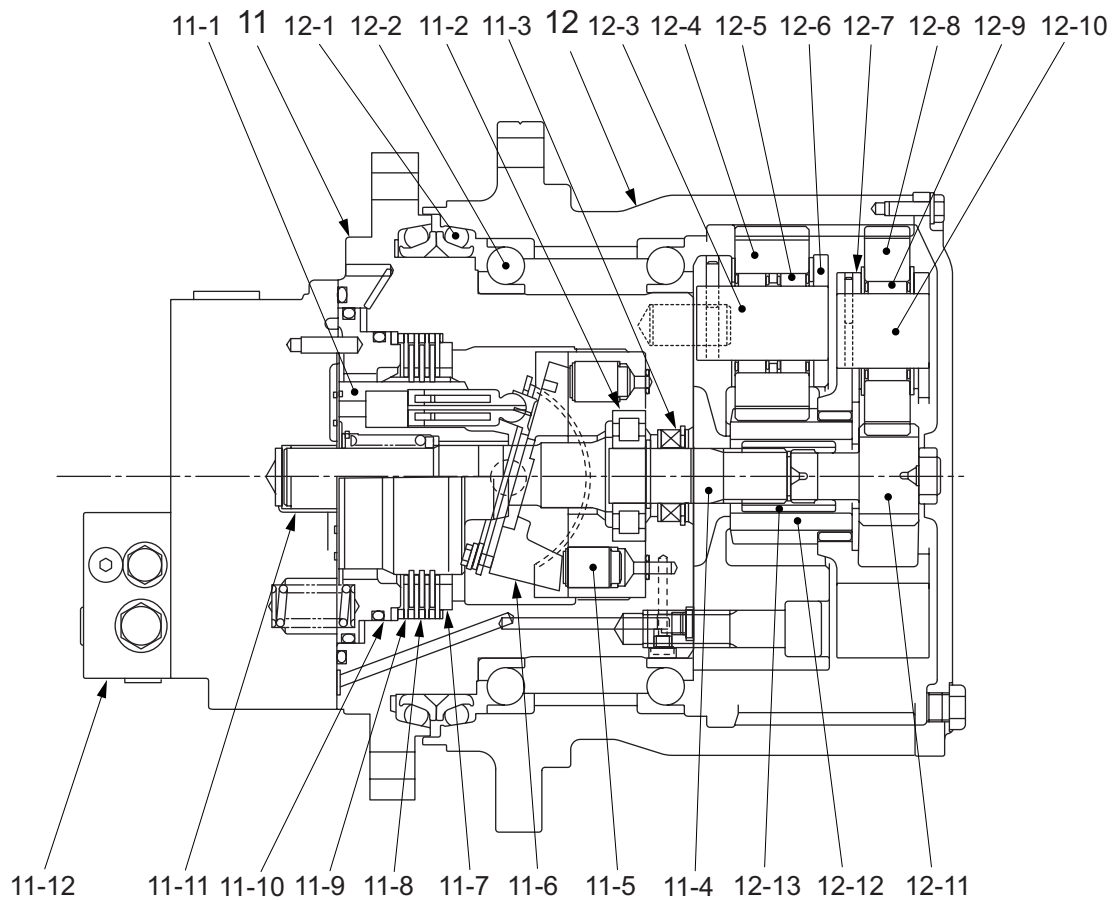

R2H-2-04003

(11) Motor

- (11-1) Cylinder block kit
- (11-2) Roller bearing
- (11-3) Oil seal
- (11-4) Shaft
- (11-5) Control piston
- (11-6) Swash plate assembly
- (11-7) Brake stopper
- (11-8) Friction plate
- (11-9) Separate plate
- (11-10) Piston brake
- (11-11) Journal bearing
- (11-12) Shift valve assembly

(12) Reduction gear

- (12-1) Floating seal kit
- (12-2) Angular bearing
- (12-3) Shaft B
- (12-4) Planetary gear B
- (12-5) Needle roller
- (12-6) Carrier B
- (12-7) Carrier A
- (12-8) Planetary gear A
- (12-9) Needle roller
- (12-10) Shaft A
- (12-11) Sun gear A
- (12-12) Sun gear B
- (12-13) Coupling

2-2-3. Propulsion hydraulic motor (rear)

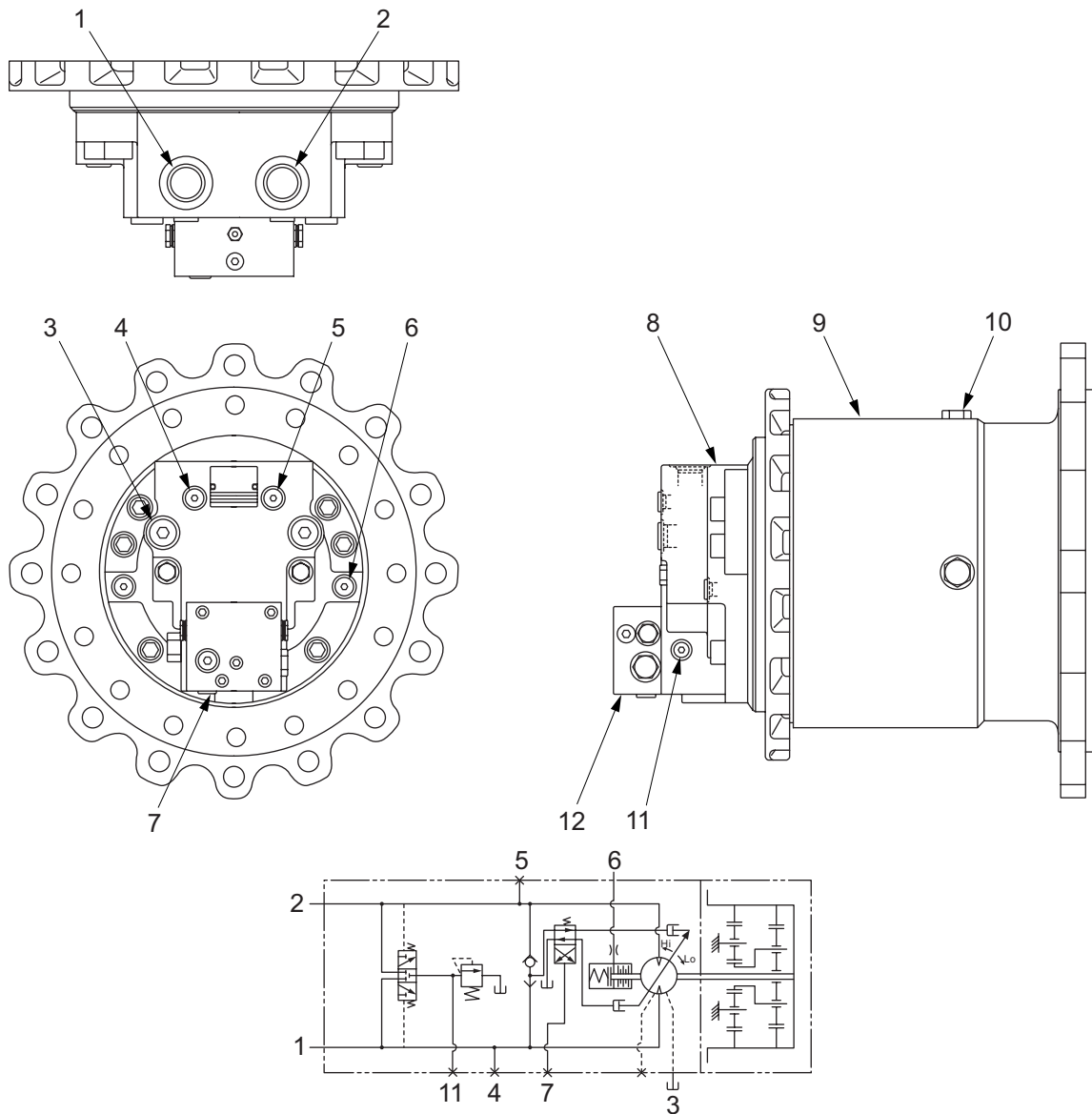

Motor circuit diagram

R2H-2-04004

- | | | | |
|---|--------------|---------------------------------|--------------|
| (1) Port B (Reverse) | [RMB] : G3/4 | (7) Speed change port | [RMS] : G1/4 |
| (2) Port A (Forward) | [RMA] : G3/4 | (8) Motor | |
| (3) Drain port | [RMD] : G1/2 | (9) Reduction gear | |
| (4) High pressure gauge port (For port B) | G1/4 | (10) Filler cap | : 7/8-14UNF |
| (5) High pressure gauge port (For port A) | : G1/4 | (11) Charge pressure gauge port | : G1/8 |
| (6) Parking brake pilot port | [RMP] : G1/4 | (12) Shift valve assembly | |

Motor specifications

- Displacement (max.) : 75.0 cm³/rev (4.58 cu.in./rev)
- Displacement (min.) : 28.0 cm³/rev (1.71 cu.in./rev)
- Charge relief valve pressure setting : 2.4 MPa (348 psi)
- Brake release pressure : 1.3 to 1.7 MPa (189 to 247 psi)
- Allowable motor case pressure : 0.3 MPa (44 psi) or less

Reduction gear specifications

- Reduction ratio : 1:39.000
- Weight : 193 kg (425 lbs.)

1) Internal structure of propulsion hydraulic motor (rear)

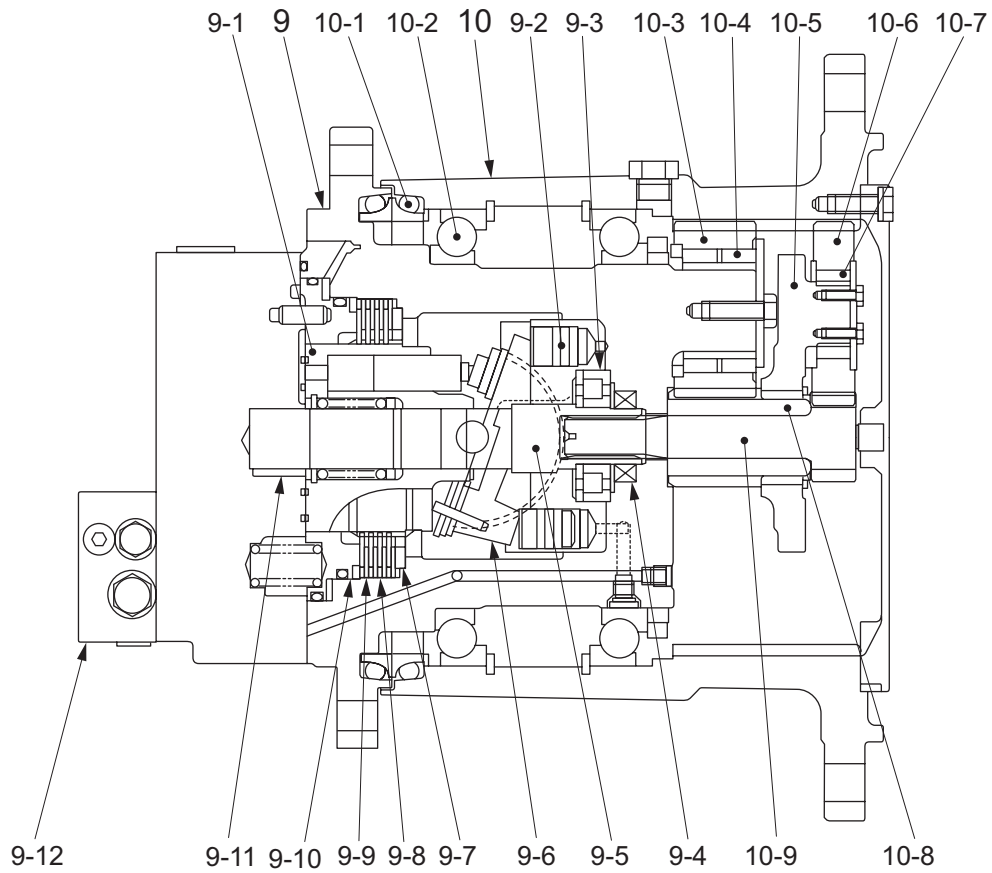

R2H-2-04005

(9) Motor

- (9-1) Cylinder block kit
- (9-2) Control piston
- (9-3) Bearing
- (9-4) Oil seal
- (9-5) Shaft
- (9-6) Swash plate assembly
- (9-7) Brake stopper
- (9-8) Friction plate
- (9-9) Separate plate
- (9-10) Piston brake
- (9-11) Journal bearing
- (9-12) Shift valve assembly

(10) Reduction gear

- (10-1) Floating seal kit
- (10-2) Angular bearing
- (10-3) Planetary gear 2nd
- (10-4) Needle roller
- (10-5) Carrier
- (10-6) Planetary gear 1st
- (10-7) Needle roller
- (10-8) Sun gear 2nd
- (10-9) Sun gear 1st

3. STEERING SYSTEM

3-1. Steering Hydraulic Piping

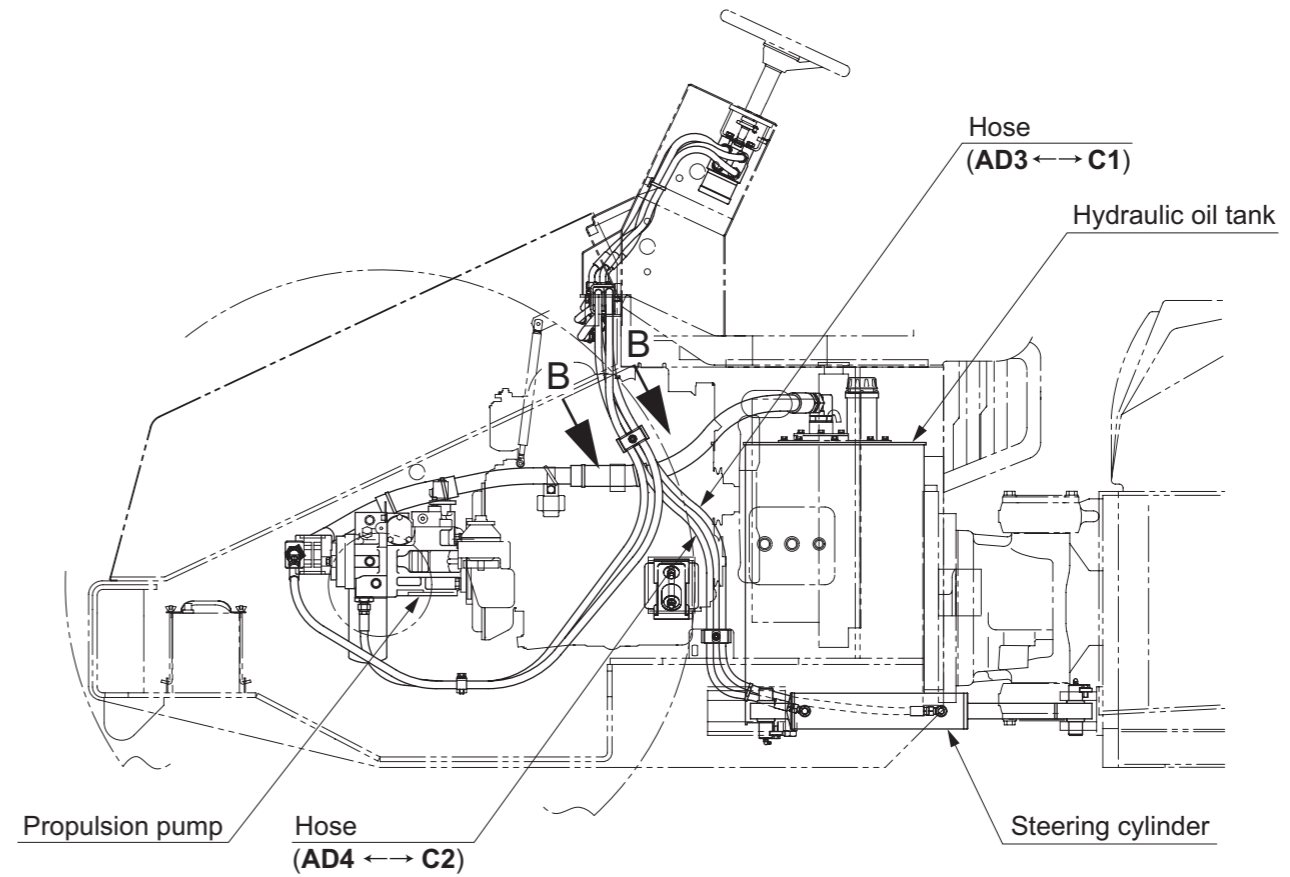
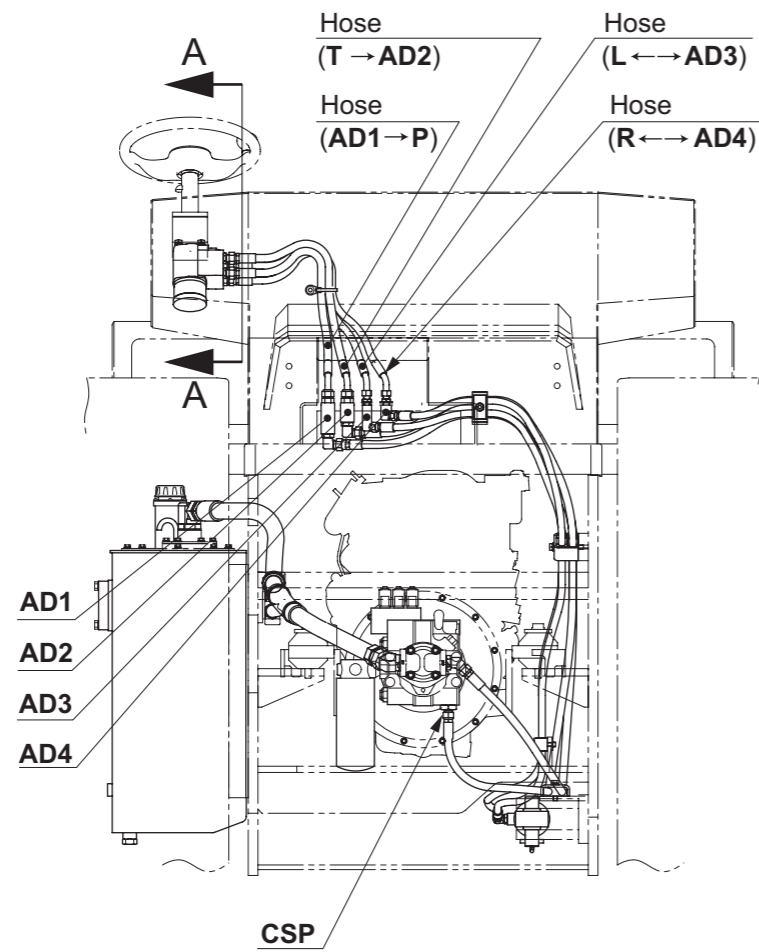
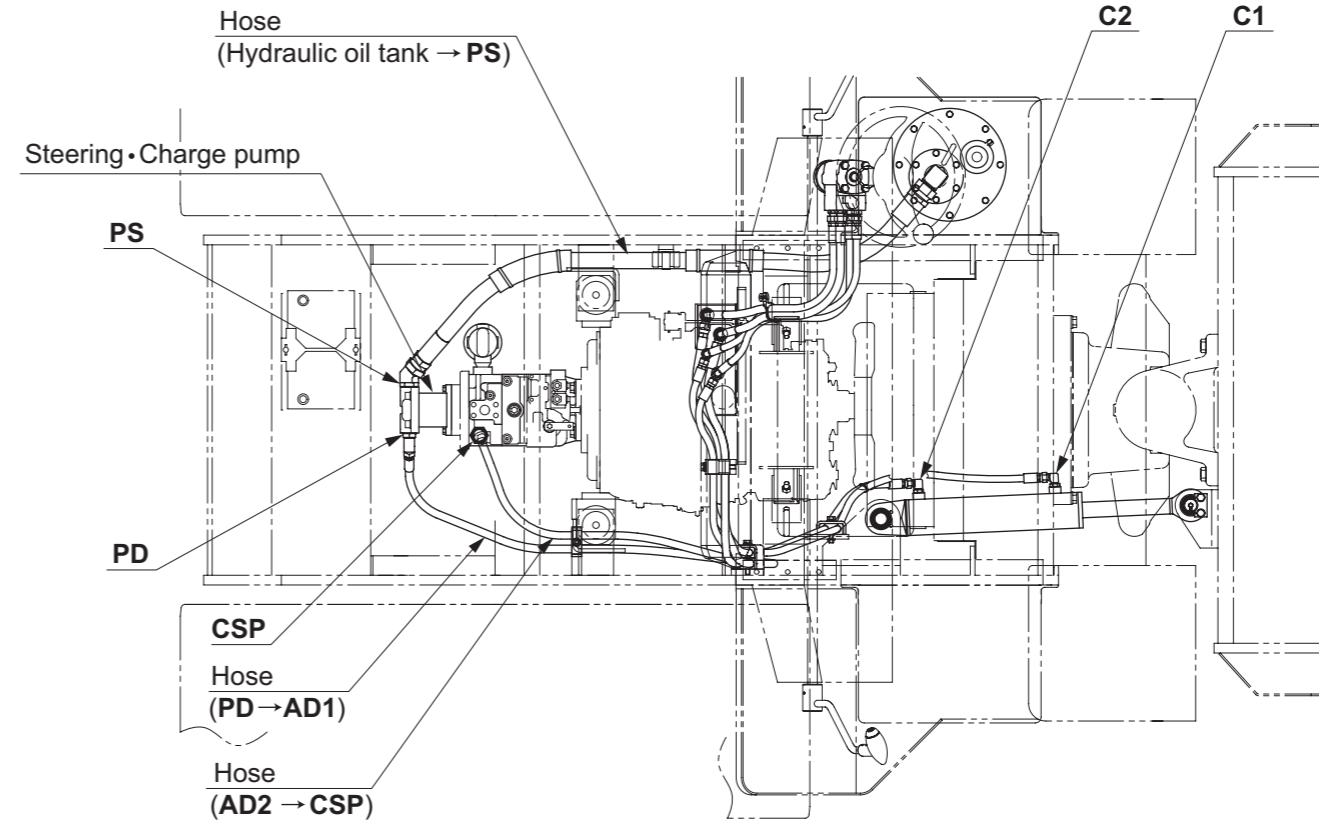
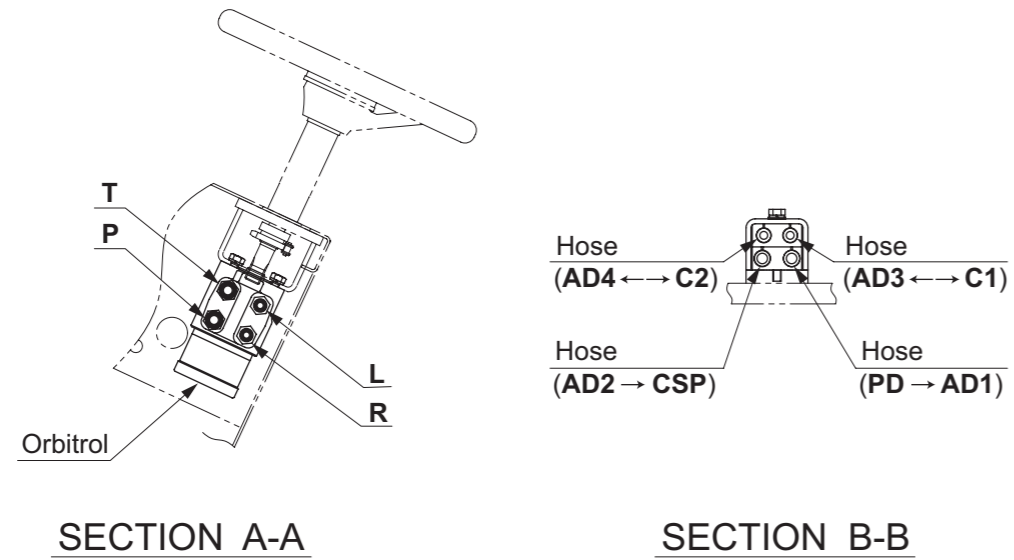

• The letters and figures (such as AD2 and CSP) show each port and the arrow (↔; →) symbols show the hose connection and the direction of the flow of the oil.

3-2. Steering Wheel

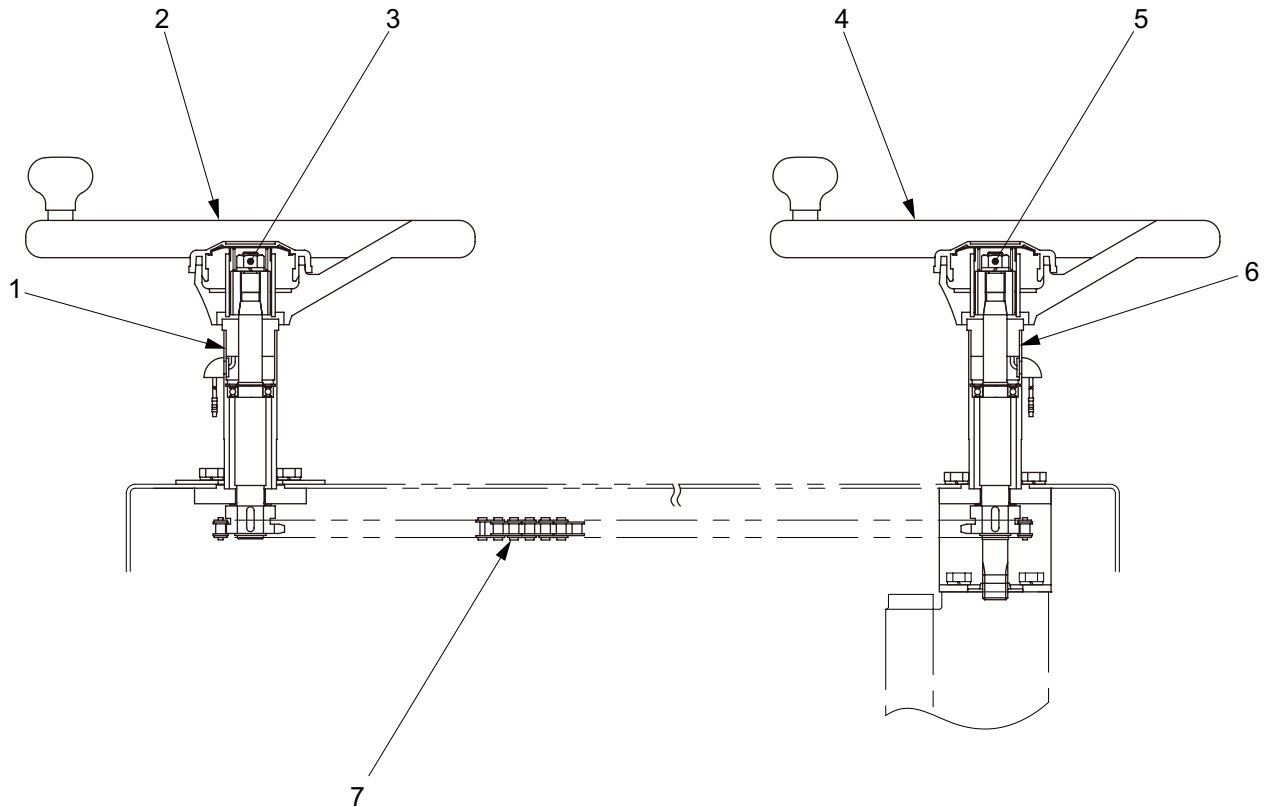

0634-32802-0-20337-A

- (1) Column shaft
- (2) Steering wheel
- (3) Nut : M12 P=1.25
- (4) Steering wheel

- (5) Nut : M12 P=1.25
- (6) Column shaft
- (7) Roller chain



- (3) Nut M12 P=1.25 : 64 N·m (47 lbf·ft)
- (5) Nut M12 P=1.25 : 64 N·m (47 lbf·ft)

- Steering wheel assembly weight : 12 kg (26 lbf·ft)

3-3. Hydraulic Component Specifications

3-3-1. Orbitrol

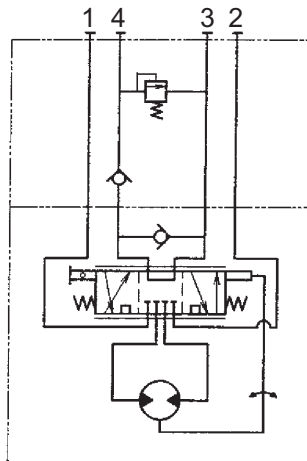
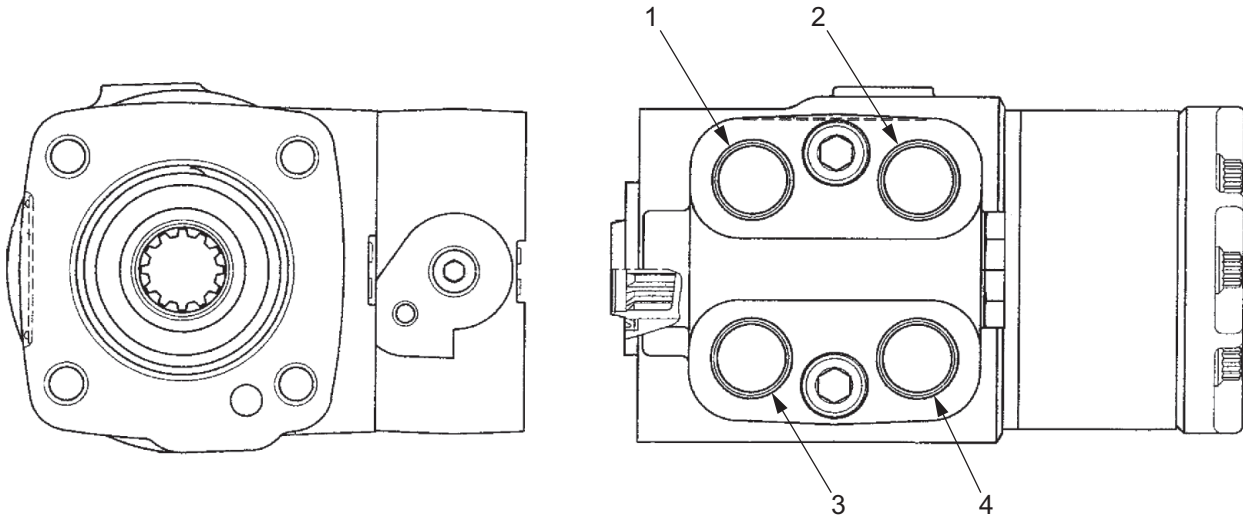

Hydraulic circuit diagram

R2H-2-04006

- (1) Port L **[L]** : 3/4-16UNF
- (2) Port R **[R]** : 3/4-16UNF
- (3) Port T **[T]** : 3/4-16UNF
- (4) Port P **[P]** : 3/4-16UNF

Specifications

- Displacement : 277 cm³/rev (16.9 cu.in./rev)
- Relief valve pressure setting : 15.2 MPa (2,204 psi)
- Weight : 7.3 kg (16.1 lbs.)

3-4. Frame (Center Pin)

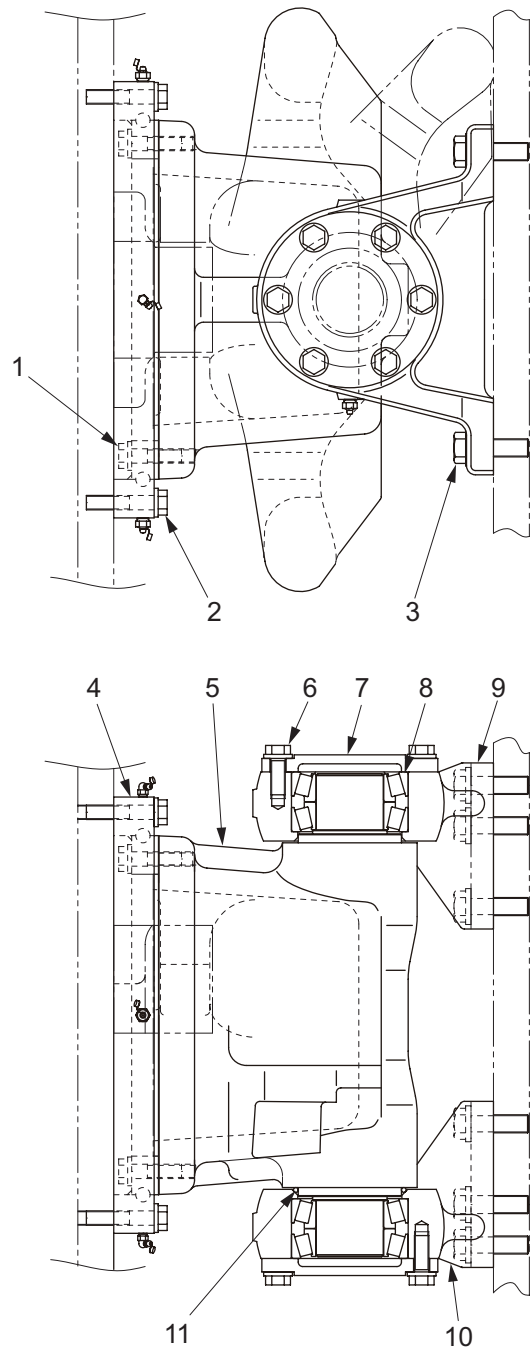

0634-61801-0-10007-D

- | | | | | |
|-------------------|----------|--------------------|----------|----------------------|
| (1) Bolt | : M16×60 | (5) Yoke | | (9) Bracket (upper) |
| (2) Bolt | : M16×80 | (6) Bolt | : M16×45 | (10) Bracket (lower) |
| (3) Bolt | : M20×70 | (7) Cover | | (11) O-ring |
| (4) Swing bearing | | (8) Roller bearing | | |



- | | |
|-----------------|--------------------------|
| (1) Bolt M16×60 | : 265 N·m (196 lbf·ft) |
| (2) Bolt M16×80 | : 265 N·m (196 lbf·ft) |
| (3) Bolt M20×70 | : 539 N·m (398 lbf·ft) |
| (6) Bolt M16×45 | : 265 N·m (196 lbf·ft) |

ELECTRICAL SYSTEM

1. ELECTRICAL CIRCUIT

1-1. Electrical Circuit Diagram

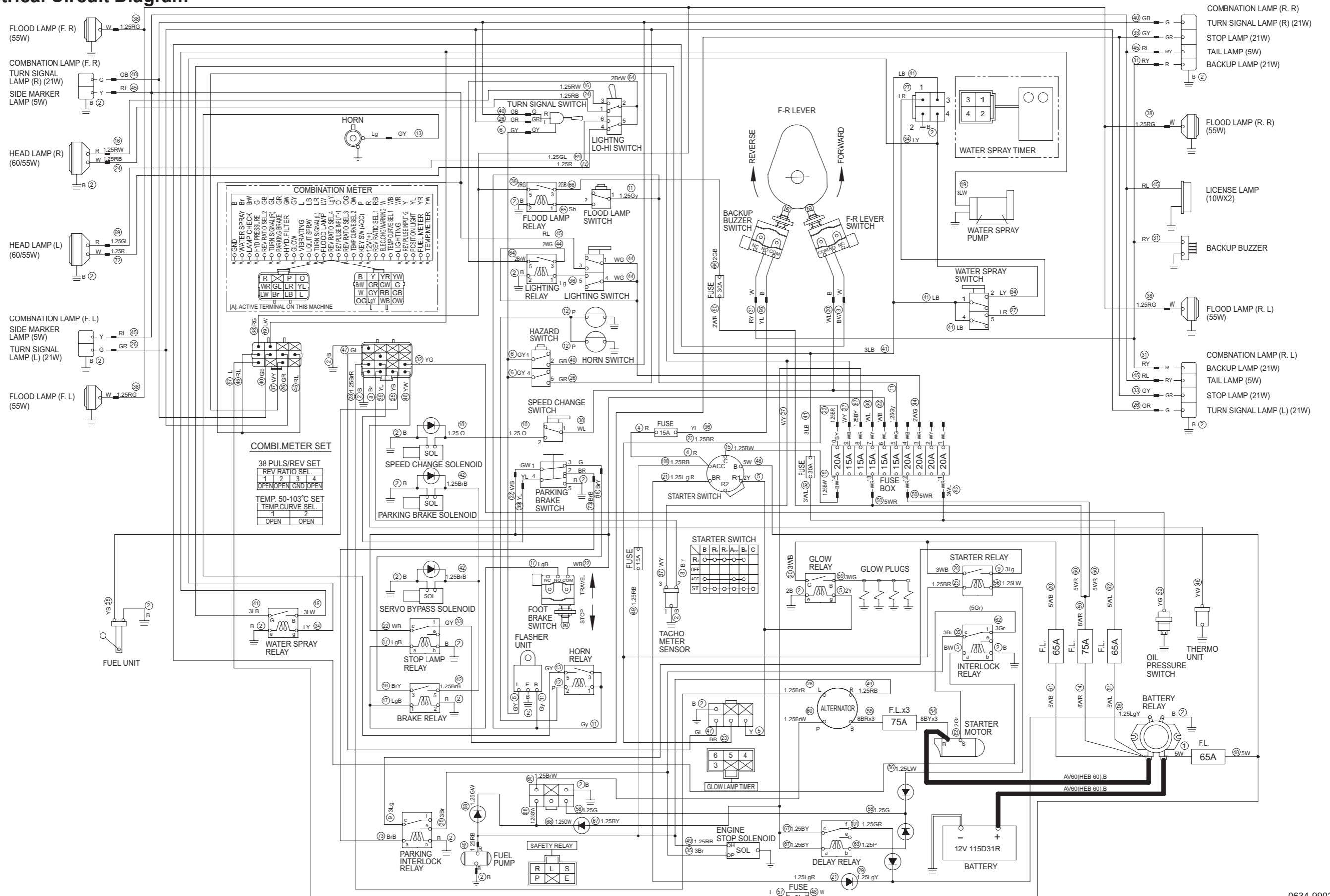

2. ELECTRICAL COMPONENTS

2-1. Electrical Component Layout (1)

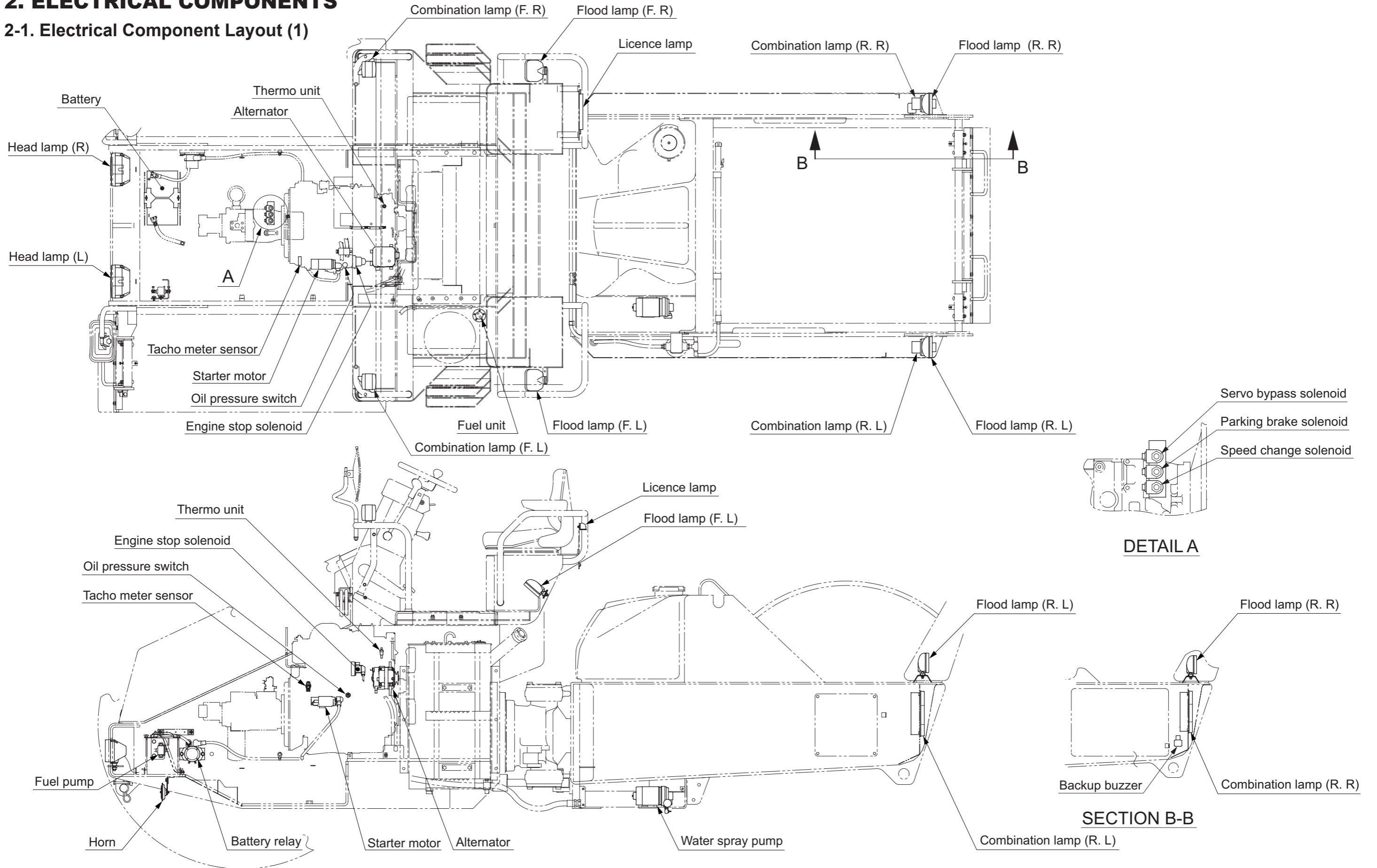

2-2. Electrical Component Layout (2)

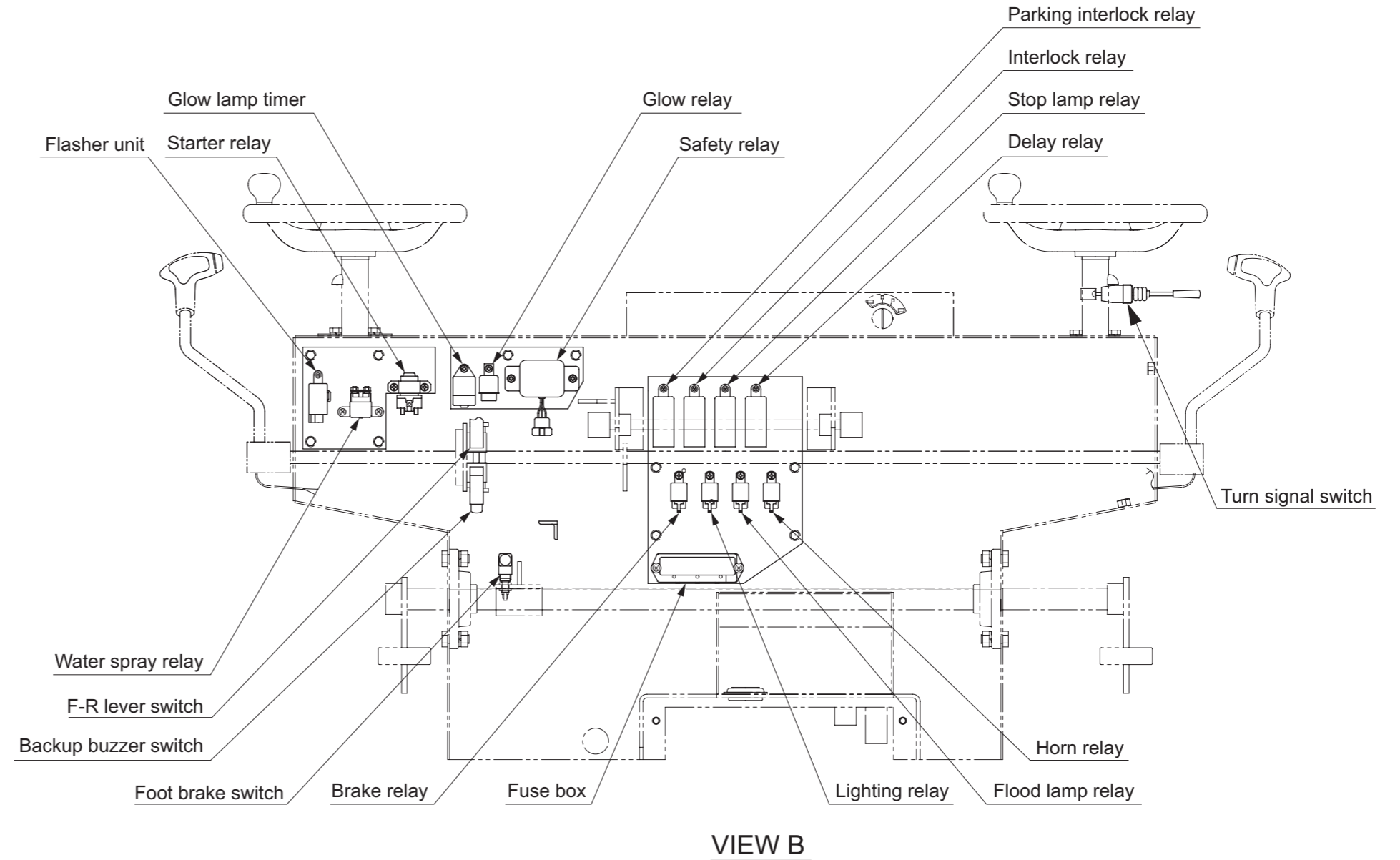
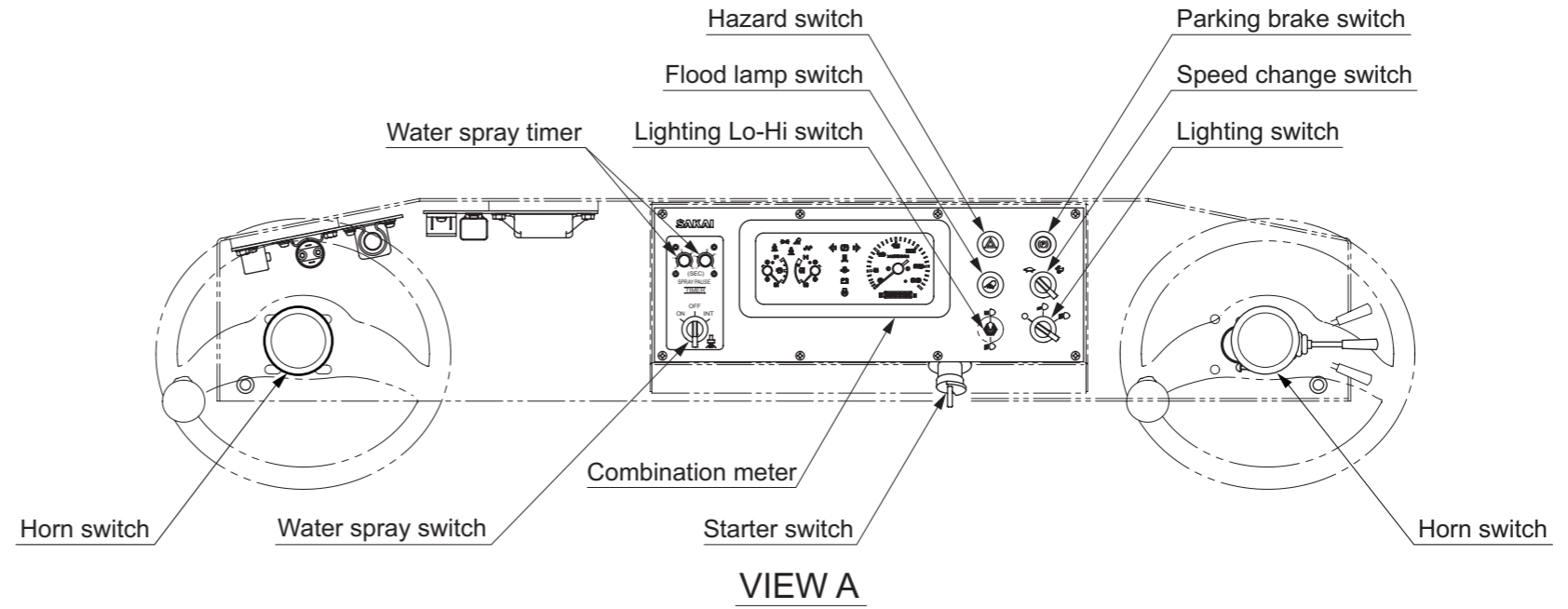
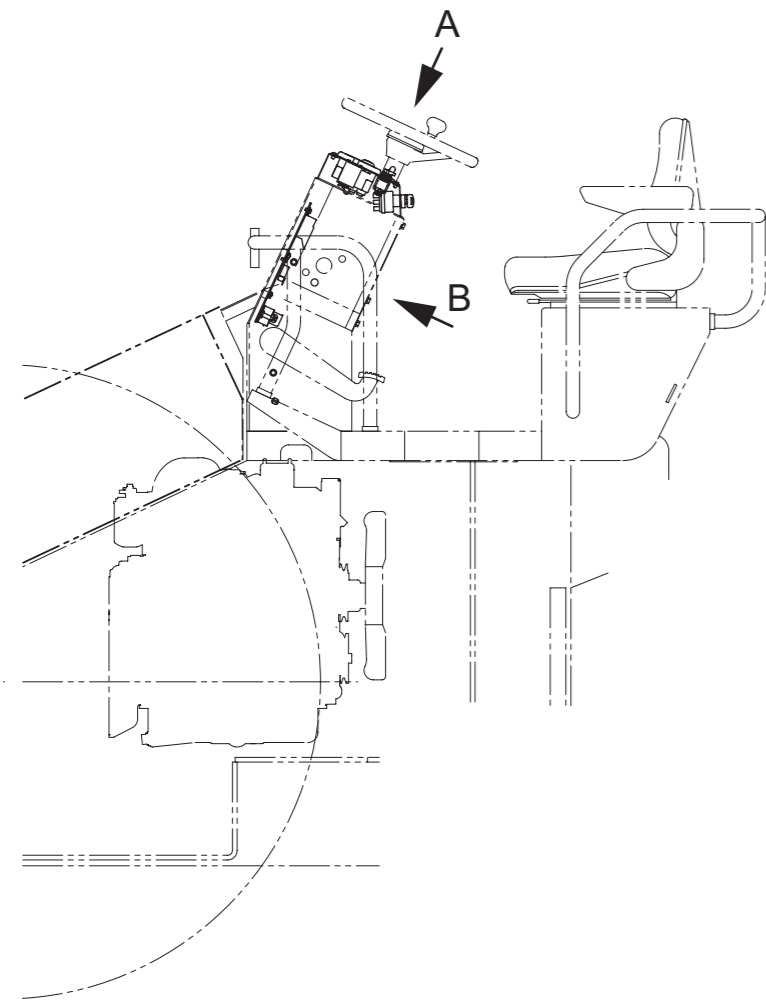

3. ELECTRICAL COMPONENT SPECIFICATIONS

3-1. Fuse Box

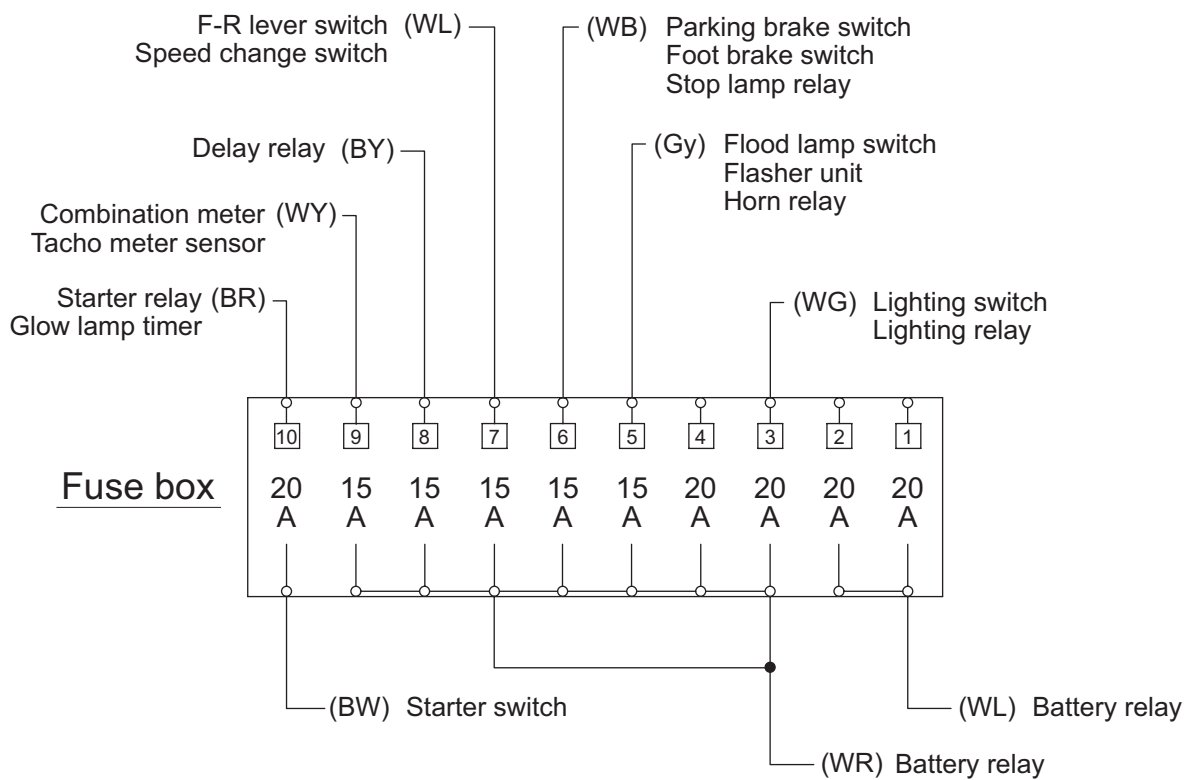

R2H-2-05001

Harness color codes

BW : Black/White stripe
 WR : White/Red stripe
 BY : Black/Yellow stripe
 WB : White/Black stripe
 BR : Black/Red stripe

WL : White/Blue stripe
 WY : White/Yellow stripe
 WG : White/Green stripe
 Gy : Gray

3-2. Combination Meter

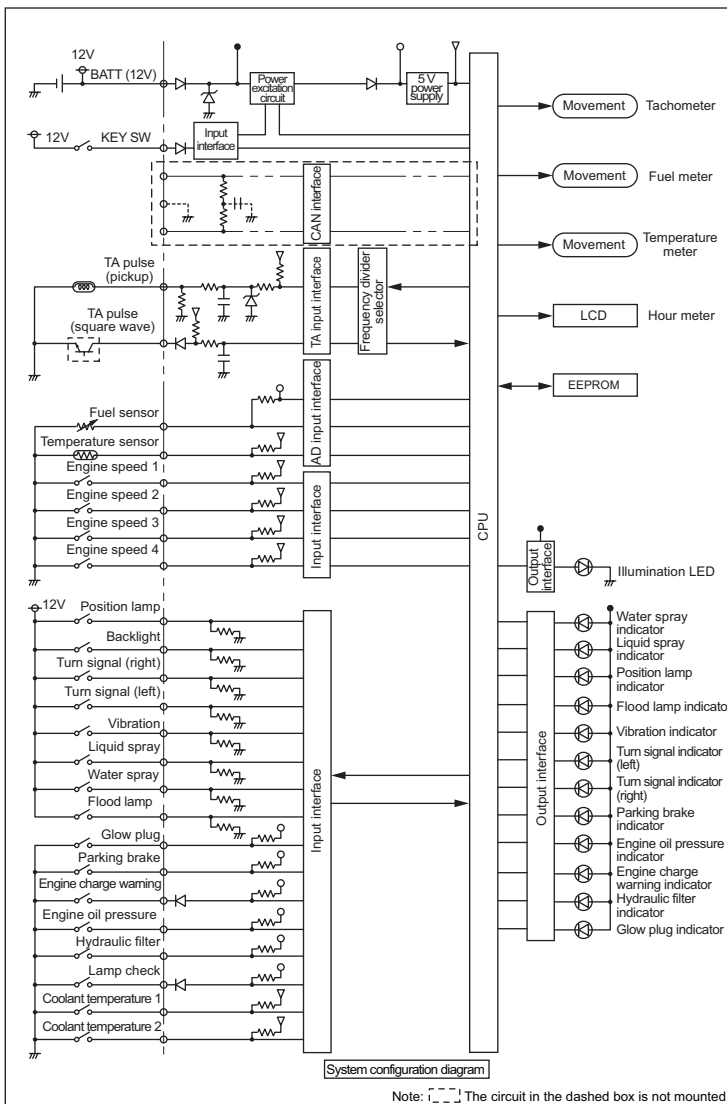
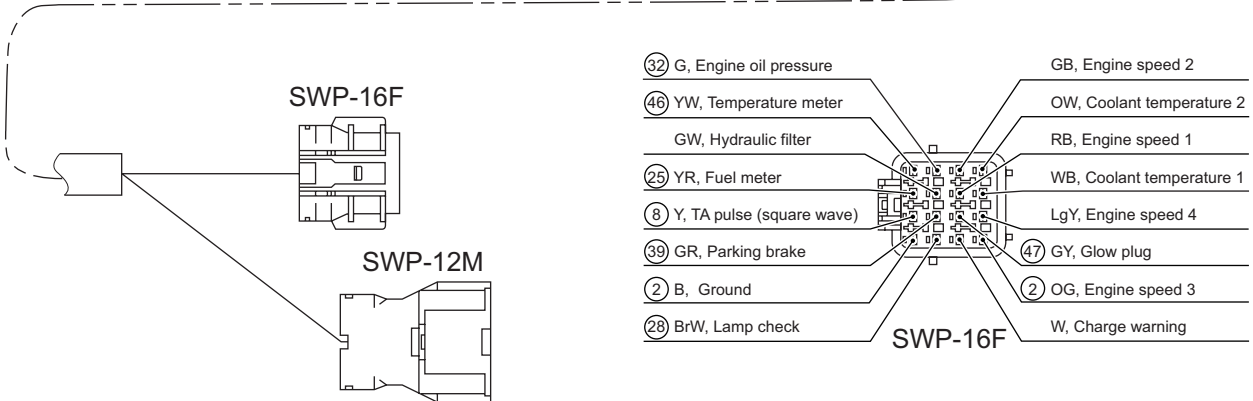
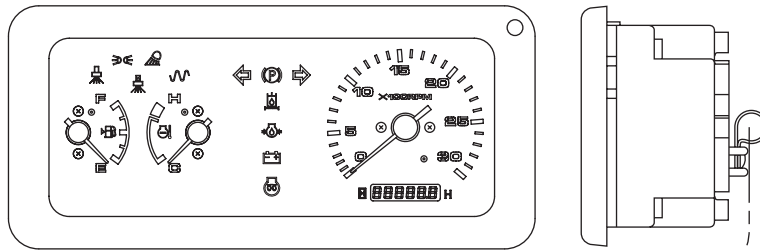

Harness side

2	28	*	2
B	BrR	*	B
8	39	47	*
Br	YL	GL	*
25	*	*	*
YB	*	*	*
46	32	*	*
YW	YG	*	*

SWP-16M

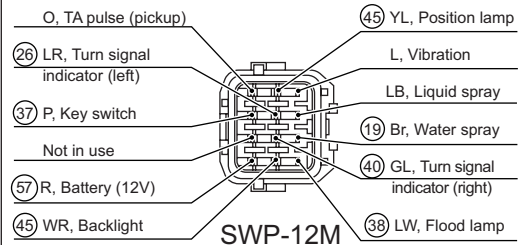

Harness side

57	45	38
L	RL	RG
*	40	19
*	GB	LW
37	26	53
WY	GR	LR
*	45	*
*	RL	*

SWP-12F

Wire color and number (Refer to "1-4 Wire Color Code and number" of TROUBLESHOOTING.)

- The arrangement of connector terminals shown below is that of connecting surfaces on the connector side.

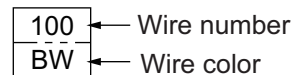

DRUM

1. PRECAUTIONS FOR DISASSEMBLY AND REASSEMBLY

- When removing, installing, disassembling or reassembling the unit, observe the general precautions described below.

1) Precautions for removal work

- Coolant that contains antifreeze should be treated as a chemical, and must not be drained carelessly on the ground.
- To prevent dust from getting into disconnected hoses and tubes, cover them with a plug or similar means.
- When draining oil, use a receptacle with sufficient capacity to receive it.
- Before proceeding with the work, look for matchmarks that show the installation location. For reassembly, place matchmarks in the required locations to prevent errors. Then remove.
- When disconnecting wiring connectors, hold the connector components so that unreasonable force is not applied to the wires.
- Label wires and hoses to ensure correct installation location.
- Confirm the number and thickness of shims prior to storage.
- When lifting parts, use lifting equipment of sufficient capacity.
- When separating parts by using pull bolts, tighten the bolts alternately.
- Before removing a unit, clean its surrounding area. Then after removal, cover it to prevent dust and other substances from getting in.
- Before removing piping for hydraulic oil or coolant, or removing related parts, satisfactorily release internal pressure.

2) Precautions for installation work

- Tighten bolts and nuts (sleeve nuts) to the specified torque (screw tightening torque table).
- When installing hoses, do not twist them or allow them to interfere with other parts.
- Replace gaskets, O-rings, split cotter pins, and lock plates with new parts.
- Properly bend split cotter pins and lock plates.
- When applying an adhesive, first clean and remove oil/grease from the surfaces properly. Then apply two or three drops to the threaded areas.
- When applying a liquid gasket, first clean and remove oil/grease from the application surface properly, and confirm that the surface is free of dust and damage. Then apply the product evenly.
- Clean parts well. Repair scratches, dents, burrs, rust, etc.
- Apply gear oil to rotating and sliding components.
- Apply grease to the surfaces of press-fit parts.
- After installing snap rings, confirm that they are properly seated in the grooves.
- Connect wiring connectors securely after cleaning off adhering oil, dust and water.
- Use lifting bolts that are not fatigued or deformed. Screw them in fully.
- When tightening a split flange, tighten screws alternately to prevent uneven tightening.
- Before installing hydraulic parts, confirm that they are free of damage and dust, etc.

3) Precautions when work is completed

- If coolant has been drained, securely retighten the drain cock and fill with coolant (mixing in long-life coolant) to the specified level. Start the engine and allow the coolant to circulate through the piping. Then add coolant again to the specified level.
- If hydraulic equipment has been removed and reinstalled, fill with hydraulic oil to the specified level. Start the engine and allow the oil to circulate through the piping. Then add oil again to the specified level.

2. FRONT DRUM

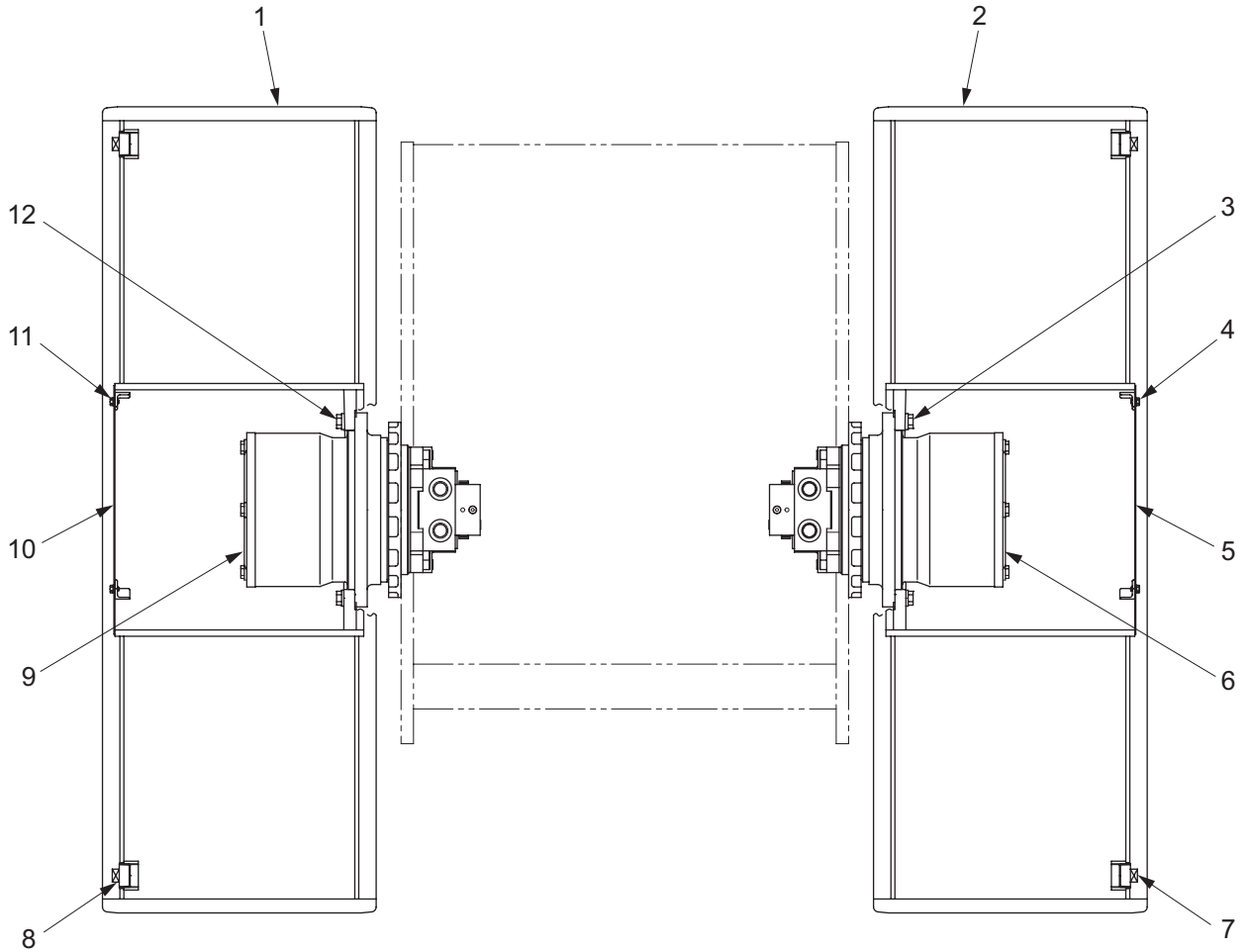

0634-24831-0-10190-A

- | | | |
|-------------------|-----------------------------|-----------------------------|
| (1) Drum (F. R) | (5) Plate | (9) Propulsion motor (F. R) |
| (2) Drum (F. L) | (6) Propulsion motor (F. L) | (10) Plate |
| (3) Bolt : M16×50 | (7) Plug | (11) Bolt : M8×12 |
| (4) Bolt : M8×12 | (8) Plug | (12) Bolt : M16×50 |



- (3) Bolt M16×50 : 265 N·m (195 lbf-ft)
 (12) Bolt M16×50 : 265 N·m (195 lbf-ft)

3. REAR DRUM

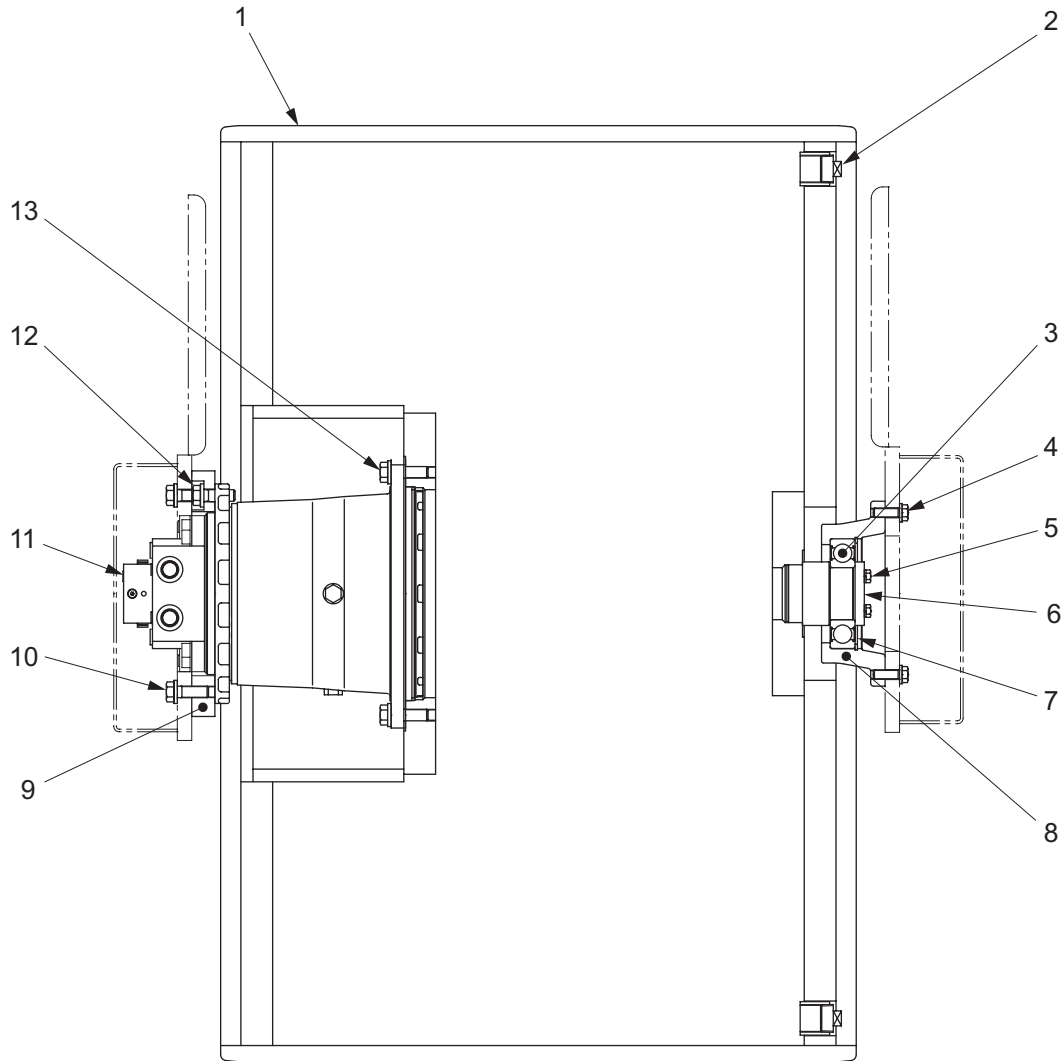

0634-27831-0-10191-B

- | | | |
|-------------------|--------------------|------------------------------|
| (1) Drum (R) | (6) End plate | (11) Propulsion motor (R) |
| (2) Plug | (7) Retaining ring | (12) Bolt : M20×60 |
| (3) Ball bearing | (8) Case | (13) Bolt : M20×70 |
| (4) Bolt : M16×50 | (9) Plate | (Apply liquid sealant to the |
| (5) Bolt : M12×40 | (10) Bolt : M20×60 | threaded area) |



- (4) Bolt M16×50 : 265 N·m (195 lbf-ft)
- (10) Bolt M20×60 : 539 N·m (398 lbf-ft)
- (12) Bolt M20×60 : 539 N·m (398 lbf-ft)
- (13) Bolt M20×70 : 539 N·m (398 lbf-ft)

BRAKE

1. BRAKE PEDAL

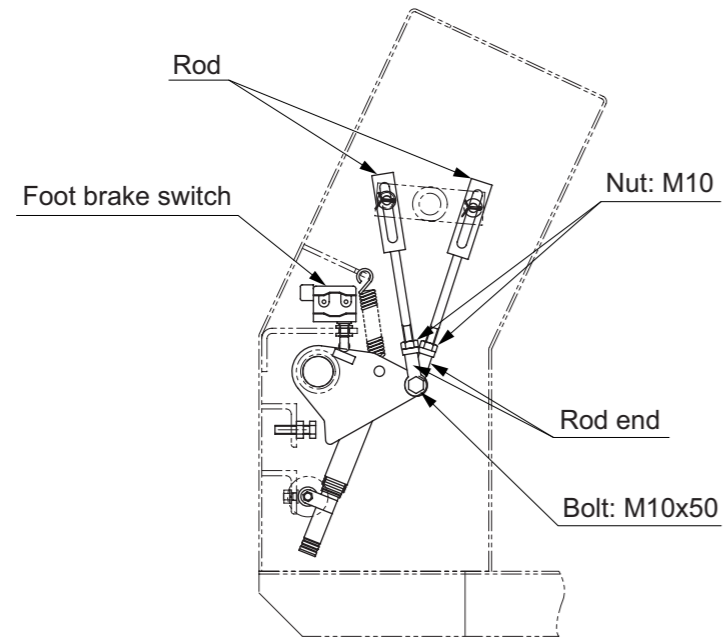

SECTION A-A

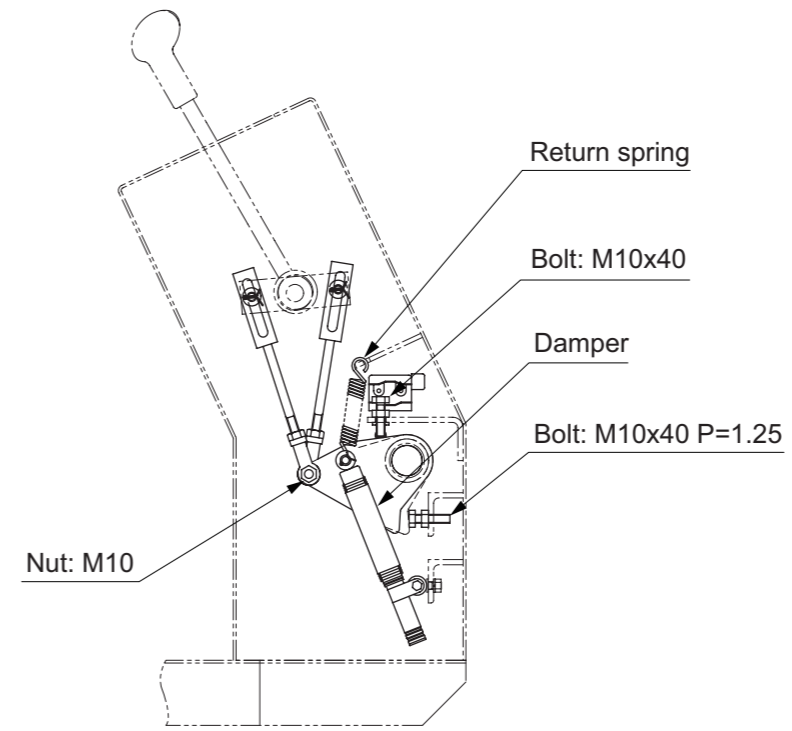

SECTION B-B

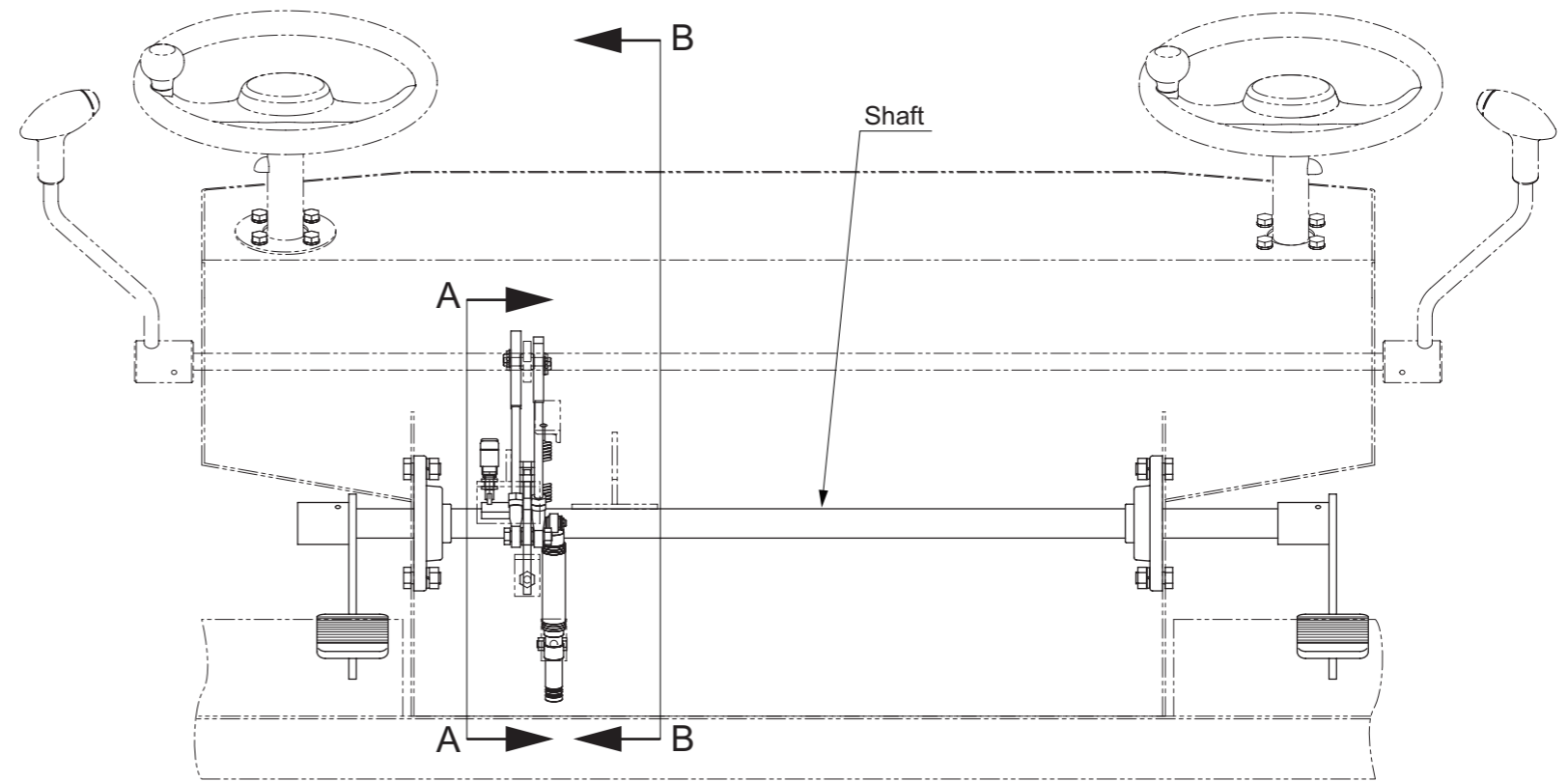
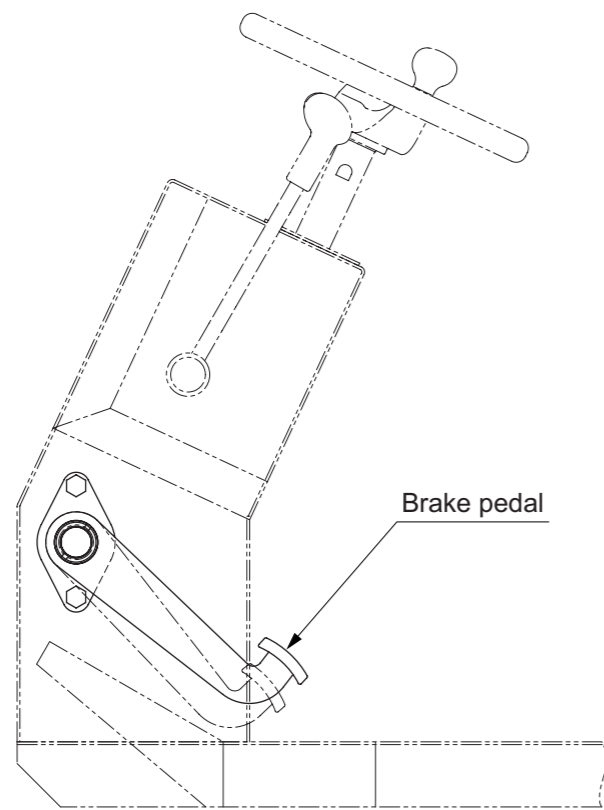

2. BRAKE SYSTEM

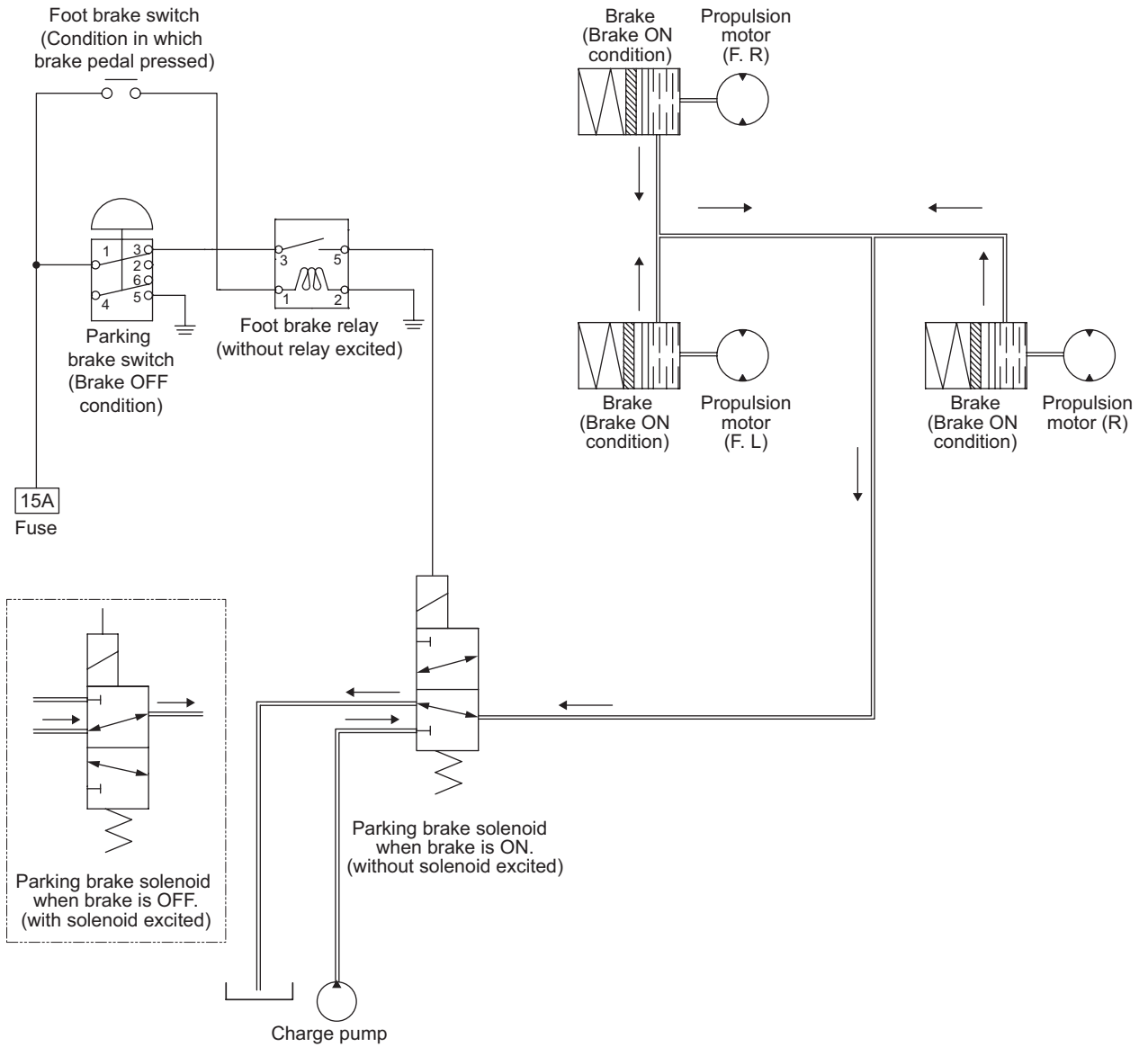

• The arrow (→) symbol shows the direction of the hydraulic oil flow.

R2H-2-07001

WATER SPRAY SYSTEM

1. WATER SPRAY PIPING

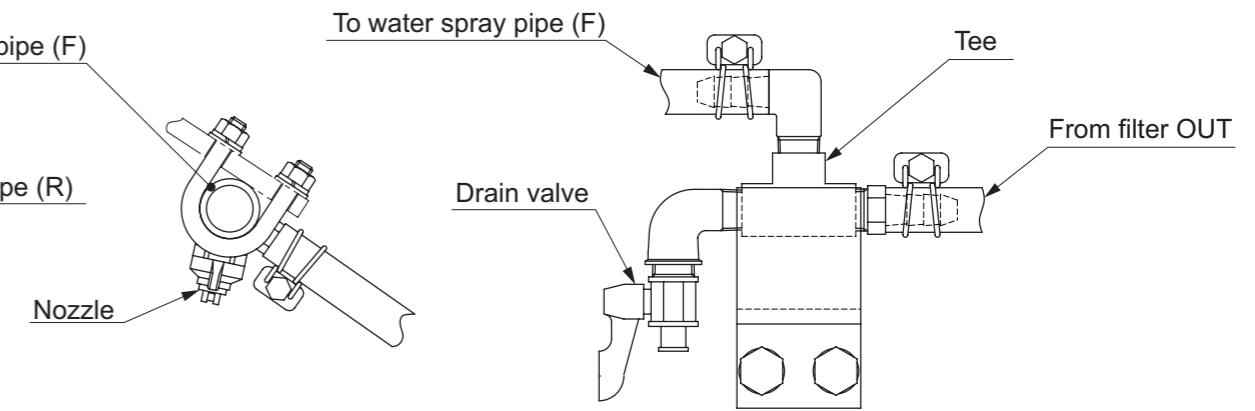
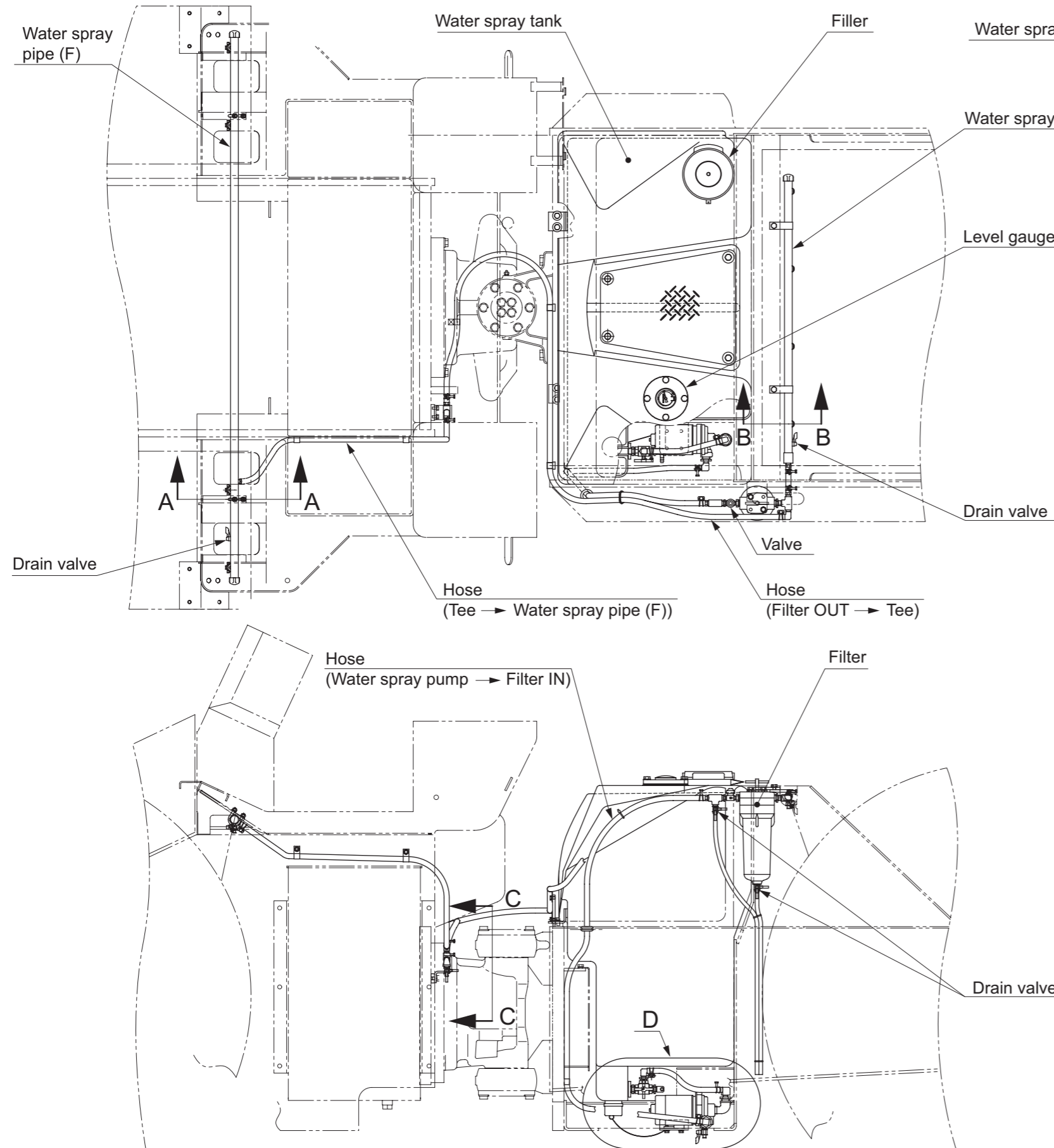

SECTION A-A

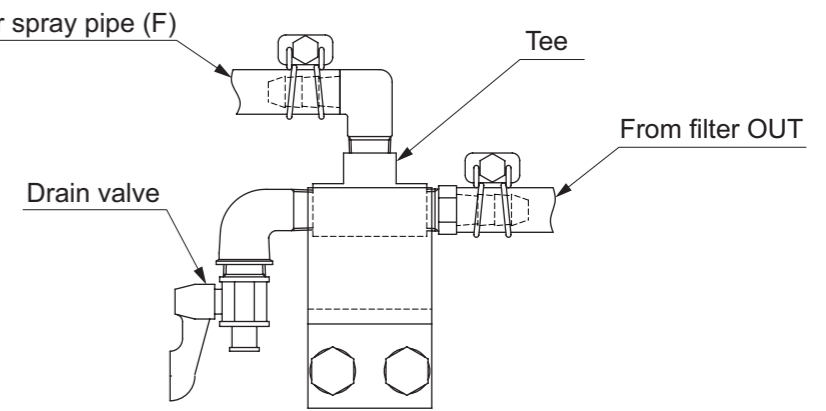

VIEW C-C

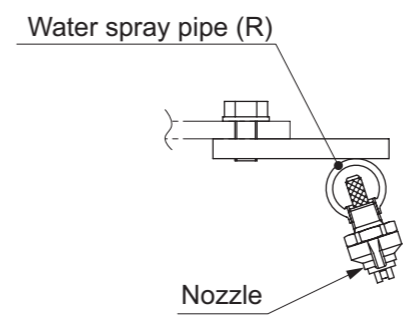

SECTION B-B

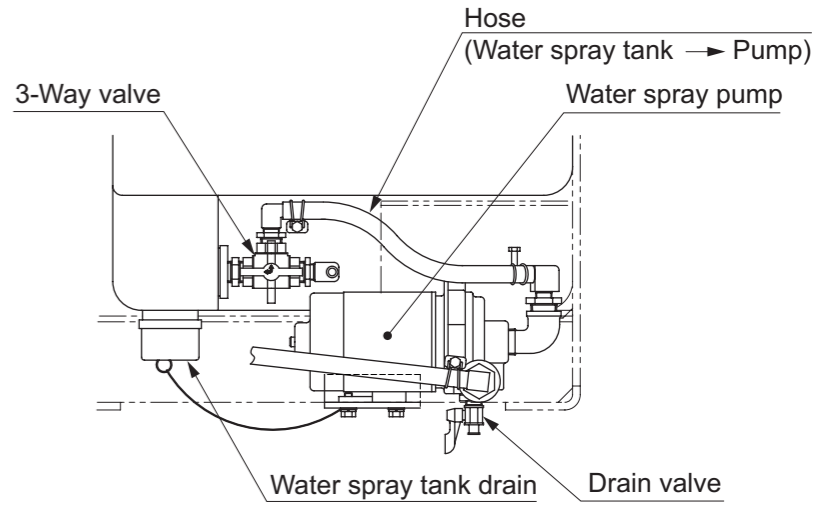

DETAIL D

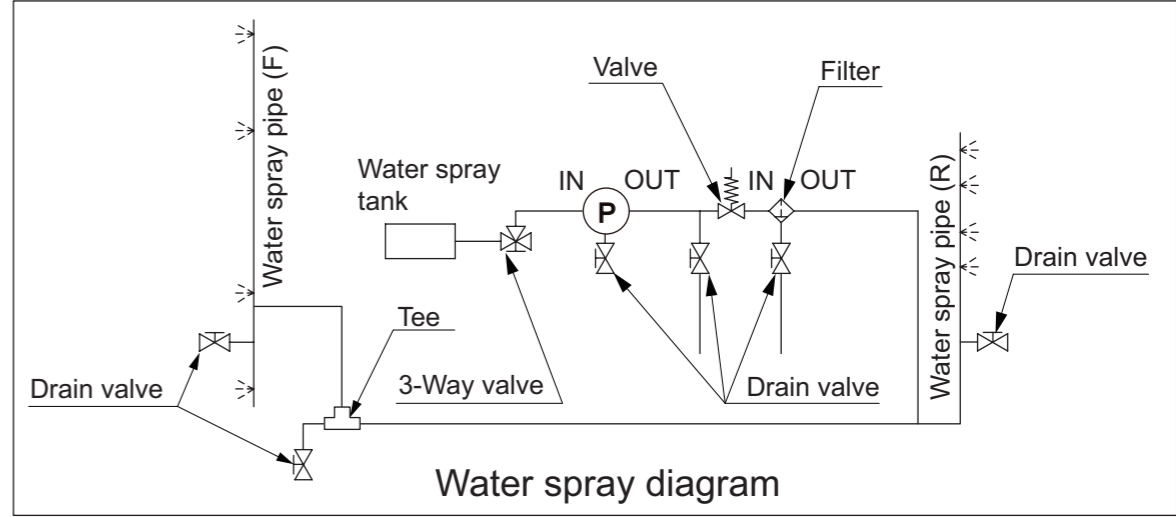

• The letters and figures (such as Filter and Water spray pipe) show each port and the arrow (→) symbols show the hose connection and the direction of the flow of the water.

INSPECTION AND ADJUSTMENT

1. INSPECTION AND ADJUSTMENT

1-1. Safety Precautions for Inspection and Adjustment

⚠ WARNING

Unexpected machine movement may cause a serious accident. When inspecting the machine while the engine is running, always follow the instructions below.

- Park the machine on level, flat ground.
- Apply the parking brake.
- Set chocks in front and behind each drum or tire.
- Make sure that service personnel are given the appropriate information at the appropriate time.
- Make sure that no one can enter any hazardous area.

⚠ CAUTION

Do not work on the hydraulic system while the engine is running and the system is hot and under pressure. Do not disconnect hydraulic hoses or fittings until the system has cooled and pressure has been properly relieved.

Before removing any plugs from the pressure measurement ports, always release any residual pressure from the piping and open the cap of the fluid tank to release and pressure.

⚠ WARNING

Inadvertent starting the engine may cause a serious accident.

When inspecting the engine, make sure to exchange the appropriate cues and hand signal with the person at the operator station to avoid any accidents.

⚠ CAUTION

Before inspecting inside of the engine compartment, always stop the engine.

Contact with the fan, V-belt or exhaust system parts while the engine is running may cause serious injury.

1-2. Preparation for Inspection and Adjustment

- Prepare the necessary measuring instruments. In addition, particularly when measuring pressure values, make sure to prepare the appropriate hoses, adapters and a plug removal tool for the pressure reading port.
- Make sure that the instruments to be used operate normally.

When handling the instruments, exercise sufficient caution not to drop or apply any impact to them. Doing so may adversely affect the calibration. Another important point is to inspect the instruments regularly. An instrument that does not start from the appropriate zero point may give an inaccurate reading.

1-3. Precautions for Inspection and Adjustment

- When performing inspections and adjustments, pay special attention to safety.
- For each inspection, always take three measurements for each measurement point. If the measurements significantly differ, the measurement method may be incorrect. In such a case, take measurements once again and calculate their average.

1-4. Warm-up

- Machinery will not exhibit their true performance under the cold condition. Before taking measurements, always warm up the engine and make sure that the fluid and engine coolant are warmed to their specified normal operating temperatures.

1-5. Inspection and Adjustment of Engine Related Items

- Refer to shop manual of engine manufacturer for inspection and adjustment of engine itself.

2. MEASUREMENT AND ADJUSTMENT OF PROPULSION CIRCUIT PRESSURE

2-1. Measurement

⚠ WARNING

Confirm that the parking brake works properly before measurement.

- Oil temperature during measurement : $50 \pm 5^{\circ}\text{C}$ ($122 \pm 41^{\circ}\text{F}$)
- ① Remove plugs from high pressure gauge port (1-8) and (1-9) of propulsion pump. Attach pressure gauge with adapter (h) .
 - Adapter : 9/16-18UNF
 - High pressure gauge port (Reverse) : (1-8)
 - High pressure gauge port (Forward) : (1-9)
 - Pressure gauge : 0 to 50 MPa
(0 to 7,250 psi)
- ② Set propulsion speed change switch to “” position.
- ③ Start the engine and set throttle lever to “Full” position.
- ④ Establish a condition in which machine propulsion load becomes maximal. (Pressure does not build up unless propulsion load is applied.)
- ⑤ With propulsion load at maximum, slowly move F-R lever to the side to be measured.
 - Then, read pressure indicated by pressure gauge.
- ⑥ After measuring, promptly return F-R lever to “Neutral” position.

★ Maximum circuit pressure

(high pressure relief valve setting)

: 41.8 ± 1.0 MPa ($6,061 \pm 145$ psi)

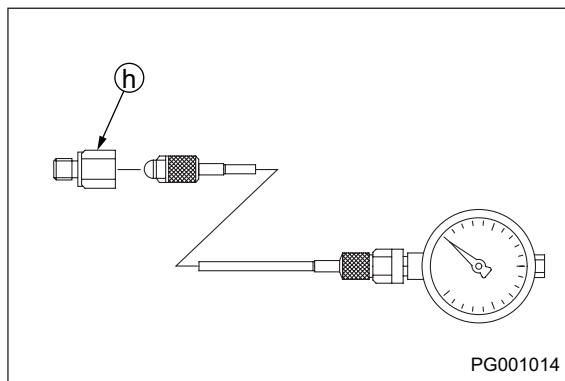
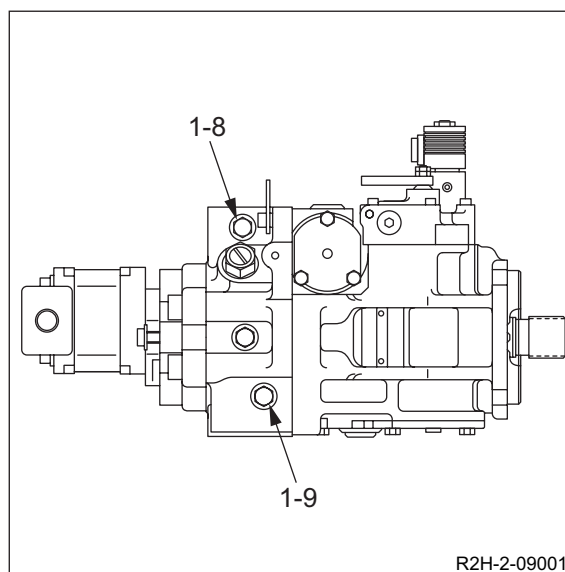

- The numbers “1-8” and “1-9” appearing in above illustrations are consistent with lead line numbers shown in illustration of propulsion pump in “2-2. Hydraulic Component Specifications” (page 4-007).

2-2. Adjustment

- If measurement results indicate the pressure deviating from maximum circuit pressure range, make an adjustment in accordance with procedure described below.

① Check nut (2) of multifunction valve (1-22) or (1-23) for evidence of having loosened.

- Multifunction valve (Reverse) : (1-22)
- Multifunction valve (Forward) : (1-23)

② If there is evidence of nut having loosened, adjust multifunction valve so that pressure becomes within maximum circuit pressure range while watching pressure gauge.

- To adjust pressure, loosen nut and turn adjustment screw (3).

Adjustment screw turned clockwise
: Pressure rise

Adjustment screw turned counterclockwise
: Pressure drop

Pressure change rate : 9 MPa/turn (1,305 psi/turn)

③ If there is no evidence of nut having loosened, remove multifunction valve.

④ Check removed multifunction valve for trapped dirt and scratches on its seat.

⑤ If trapped dirt is present, disassemble and clean multifunction valve.

⑥ If a scratch is found on seat, replace multifunction valve.

⑦ After adjustment, measure pressure again and check that pressure reaches maximum circuit pressure range.



(1)	Nut	: 41 N·m (30 lbf·ft)
(2)	Nut	: 20 N·m (16 lbf·ft)
(1-22) and (1-23)	Multifunction valve	: 89 N·m (66 lbf·ft)

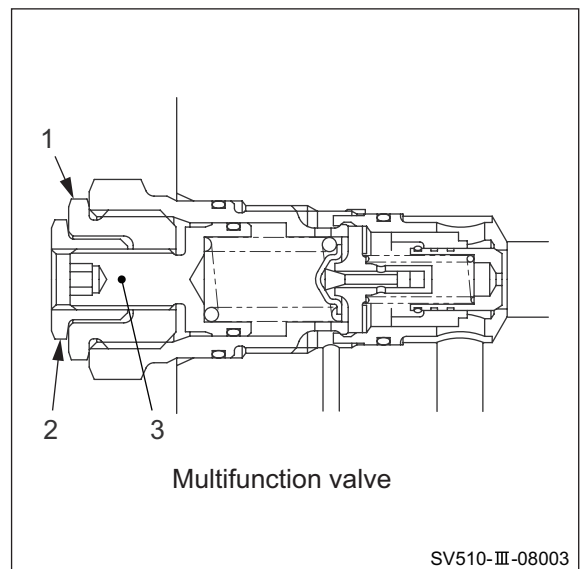
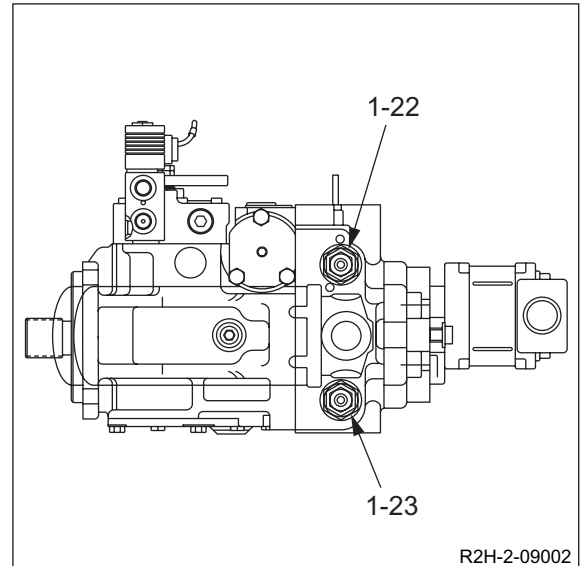

(NOTICE)

- **Carefully disassemble and reassemble after taking steps to prevent foreign material from getting in.**
- The numbers “1-22” and “1-23” appearing in above illustrations are consistent with lead line numbers shown in illustration of propulsion pump in “2-2. Hydraulic Component Specifications” (page 4-007).

3. MEASUREMENT AND ADJUSTMENT OF PROPULSION CHARGE CIRCUIT PRESSURE

- Since oil in charge circuit is supplied from steering circuit, confirm that steering operation is normal before measurement.
- Ensure that neutral positions of F-R lever and hydraulic pump are aligned.

3-1. Measurement

- Oil temperature during measurement : $50 \pm 5^{\circ}\text{C}$ ($122 \pm 41^{\circ}\text{F}$)
- ① Remove plug from charge pressure gauge port (1-2).
Attach pressure gauge with adapter (h).
 - Adapter (h) : 9/16-18UNF
 - Pressure gauge : 0 to 5 MPa (0 to 725 psi)
- ② Apply parking brake by pressing parking brake switch button.
- ③ Start the engine and set throttle lever to "Full" position.
 - Then, read pressure indicated by pressure gauge.

★ Standard charge relief valve setting

: 2.4 ± 0.2 MPa (348 ± 29 psi)

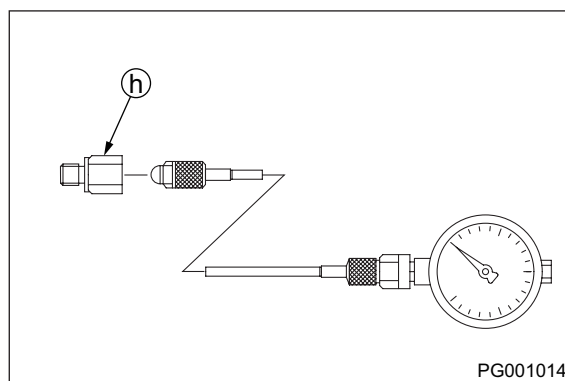
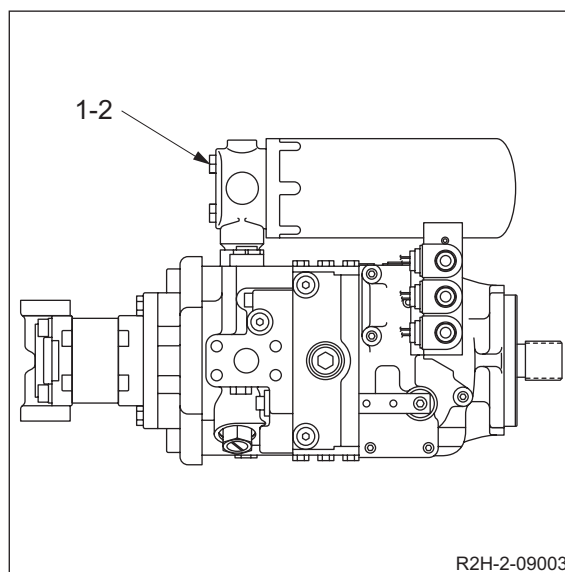

- The number "1-2" appearing in above illustrations is consistent with lead line numbers shown in illustration of propulsion pump in "2-2. Hydraulic Component Specifications" (page 4-007).

3-2. Adjustment

- If measurement results indicate the pressure deviating from standard charge relief valve setting range, make an adjustment in accordance with procedure described below.
- ① Check nut (2) of charge relief valve (1-7) for evidence of having loosened.
 - ② If there is evidence of nut having loosened, adjust charge relief valve so that pressure becomes within standard charge relief valve pressure setting range while watching pressure gauge.
 - To adjust pressure, loosen nut and turn adjustment screw (3).
- Adjustment screw turned clockwise
: Pressure rise
- Adjustment screw turned counterclockwise
: Pressure drop
- Pressure change rate : 0.39 MPa/turn (57 psi/turn)
- ③ If there is no evidence of nut having loosened, remove charge relief valve.
 - ④ Check removed charge relief valve for trapped dirt and scratches on its seat.
 - ⑤ If trapped dirt is present, disassemble and clean charge relief valve.
 - ⑥ If a scratch is found on seat, replace charge relief valve.
 - ⑦ After adjustment, measure pressure again and check that pressure reaches standard charge relief valve setting range.

 N·m (2) Nut : 52 N·m (38 lbf·ft)

(NOTICE)

- **Carefully disassemble and reassemble after taking steps to prevent foreign material from getting in.**

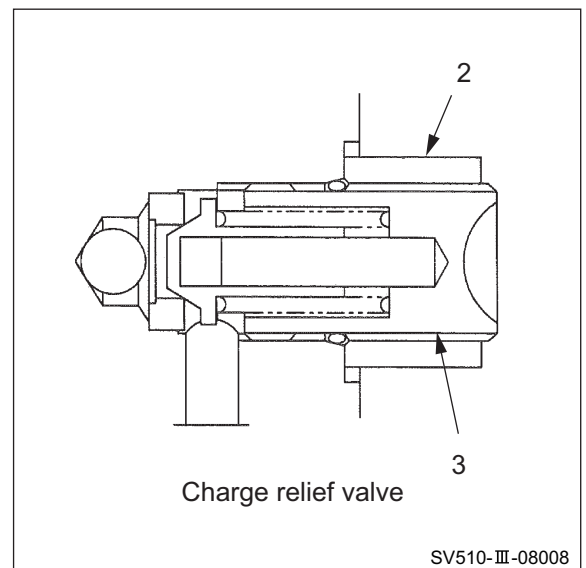
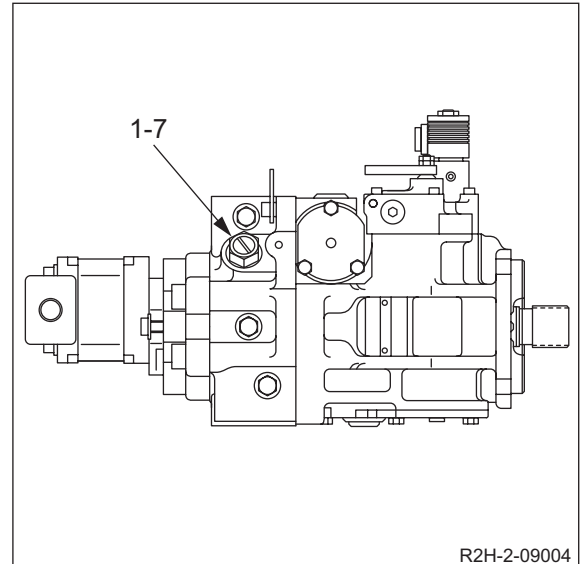

- The number “1-7” appearing in above illustrations is consistent with lead line numbers shown in illustration of propulsion pump in “2-2. Hydraulic Component Specifications” (page 4-007).

4. MEASUREMENT OF PROPULSION SERVO CIRCUIT PRESSURE

4-1. Measurement

- Oil temperature during measurement : $50 \pm 5^{\circ}\text{C}$ ($122 \pm 41^{\circ}\text{F}$)
- ① Disconnect hoses (1) and (2) from propulsion pump.
Attach pressure gauge through adapter (m) .
 - Adapter (m) : G1/4
 - Pressure gauge : 0 to 5 MPa (0 to 725 psi)
- ② Apply parking brake by pressing parking brake switch button.
- ③ Start the engine and set throttle lever to "Full" position.
- ④ Operate F-R lever and then read pressure indicated by pressure gauge.
 - With parking brake "ON", measured pressures of (1) and (2) are same.
 - With parking brake "OFF", measured pressures of (1) and (2) are different.

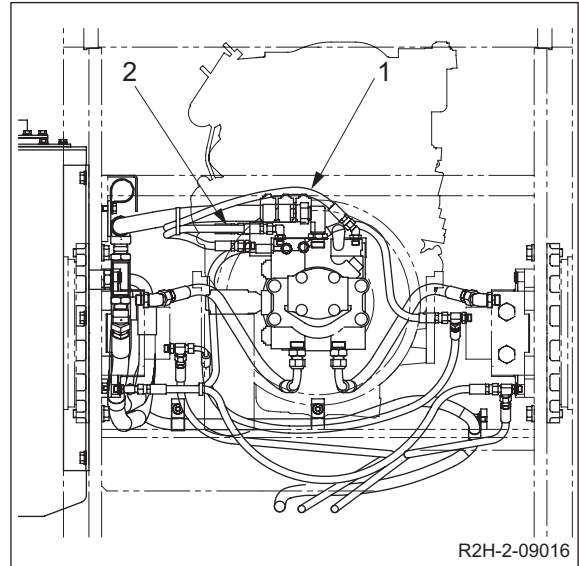

★ Standard charge relief pressure setting

: 2.4 ± 0.2 MPa (348 ± 29 psi)

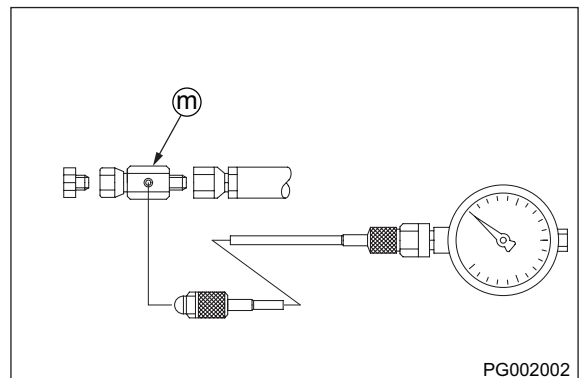

5. MEASUREMENT OF MACHINE HIGH/LOW SPEED CHANGE CIRCUIT PRESSURE

- Since oil in charge circuit is supplied from steering circuit, confirm that steering operation is normal before measurement.

5-1. Measurement

- Oil temperature during measurement : $50 \pm 5^{\circ}\text{C}$ ($122 \pm 41^{\circ}\text{F}$)
- ① Disconnect hose (1) from rear propulsion motor. Attach pressure gauge through adapter (m) .
 - Adapter (m) : G1/4
 - Pressure gauge : 0 to 5 MPa (0 to 725 psi)
- ② Apply parking brake by pressing parking brake switch button.
- ③ Set propulsion speed change switch to “” position.
- ④ Start the engine and set throttle lever to “Full” position.
 - Then, read pressure indicated by pressure gauge.

★ Standard charge relief valve setting

: 2.4 ± 0.2 MPa (348 \pm 29 psi)

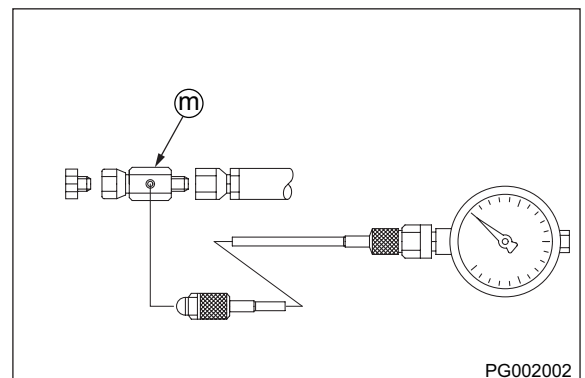
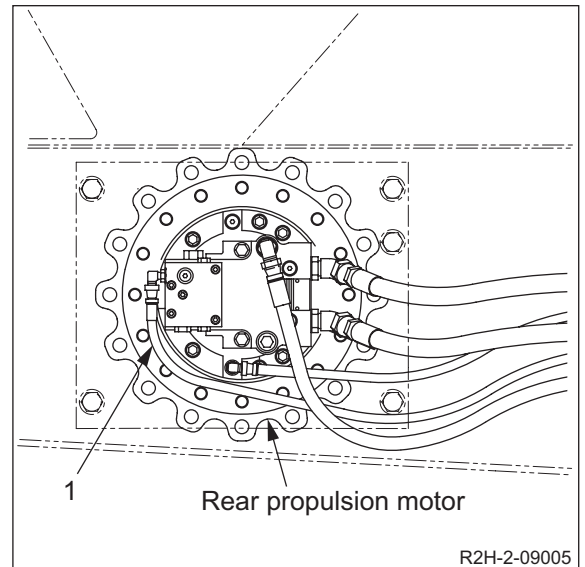

6. MEASUREMENT OF PARKING BRAKE RELEASE PRESSURE

- Since oil in charge circuit is supplied from steering circuit, confirm that steering operation is normal before measurement.

6-1. Measurement

- Oil temperature during measurement : $50 \pm 5^{\circ}\text{C}$ ($122 \pm 41^{\circ}\text{F}$)
- ① Remove plug from parking brake pilot port (1). Attach pressure gauge with adapter ② .
 - Adapter ② : G1/4
 - Pressure gauge : 0 to 5 MPa (0 to 725 psi)
- ② Confirm that F-R lever is in "Neutral" position.
- ③ Apply parking brake by pressing parking brake switch button.
- ④ Start the engine and set throttle lever to the "Full" position.
- ⑤ Release parking brake by pressing parking brake switch button.
 - Then, read brake release pressure indicated by pressure gauge.

★ Brake release pressure

Front motor : 1.3 to 1.7 MPa (189 to 247 psi)

Rear motor : 1.3 to 1.6 MPa (189 to 232 psi)

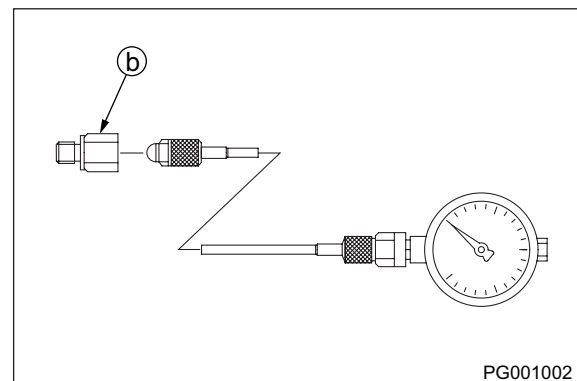
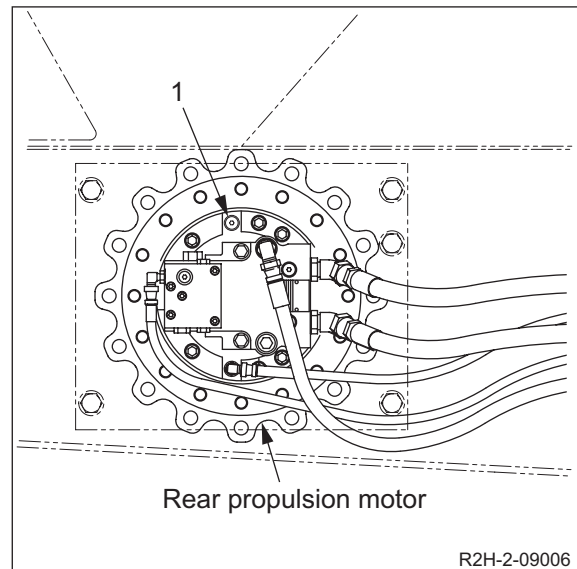

7. MEASUREMENT AND INSPECTION OF STEERING CIRCUIT PRESSURE

7-1. Measurement

⚠ WARNING

Make sure that there is no person around the articulated portion of the machine before operating the steering wheel.

- Oil temperature during measurement : $50 \pm 5^{\circ}\text{C}$ ($122 \pm 41^{\circ}\text{F}$)
- ① Disconnect hose (1) from steering charge pump.
Attach pressure gauge through adapter ⑨ .
 - Adapter ⑨ : G3/4
 - Pressure gauge : 0 to 25 MPa (0 to 3,625 psi)
- ② Confirm that F-R lever is in "Neutral" position properly.
- ③ Start the engine and set throttle lever to "Full" position.
 - Turn steering wheel to operate relief valve.
 - Then, read pressure indicated by pressure gauge.

★ **Standard maximum circuit pressure**
(orbitroll relief pressure + charge relief pressure)
: 17.6 ± 1.0 MPa ($2,552 \pm 145$ psi)

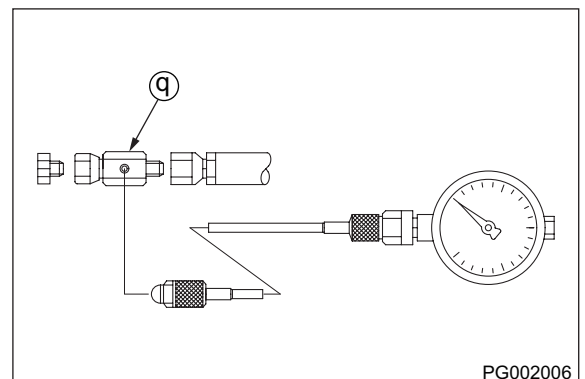
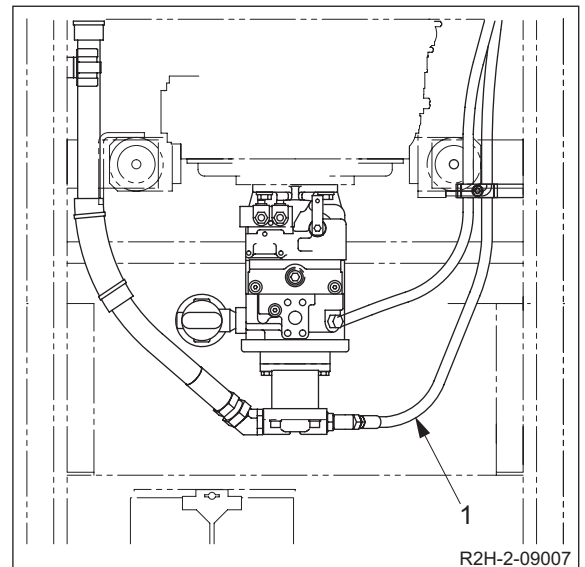

7-2. Inspection

- If measurement results indicate the pressure deviating from standard maximum circuit pressure range, make an adjustment in accordance with procedure described below.

- ① Remove relief valve (2) from orbitrol.
- ② Check removed relief valve for trapped dirt, scratches on its seat and other abnormalities.
- ③ If trapped dirt is present, disassemble and clean relief valve.
- ④ If a scratch or any other abnormality is found on seat, replace relief valve.
- ⑤ After inspection, measure pressure again and check that pressure reaches standard maximum circuit pressure range.

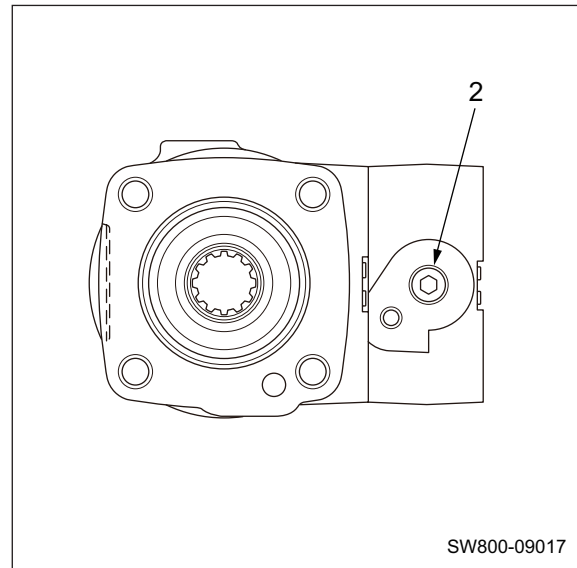

(NOTICE)

- **Carefully disassemble and reassemble after taking steps to prevent foreign material from getting in.**



8. MEASUREMENT OF HYDRAULIC PUMP CASE PRESSURE

8-1. Measurement of Propulsion Pump Case Pressure

- Oil temperature during measurement : $50 \pm 5^{\circ}\text{C}$ ($122 \pm 41^{\circ}\text{F}$)
- ① Disconnect hose (1) from propulsion pump. Attach pressure gauge through adapter ⑨ .
 - Adapter ⑨ : G 3/4
 - Pressure gauge : 0 to 5 MPa (0 to 725 psi)
- ② Set propulsion speed change switch to “” position.
- ③ Start the engine and set throttle lever to “Full” position.
- ④ Establish a condition in which machine propulsion load becomes maximal. (Pressure does not build up unless propulsion load is applied.)
- ⑤ With propulsion load at maximum, measure pressure when speed change switch is in “” and “” positions and F-R lever is in “neutral”, “forward”, and “reverse” positions, respectively.

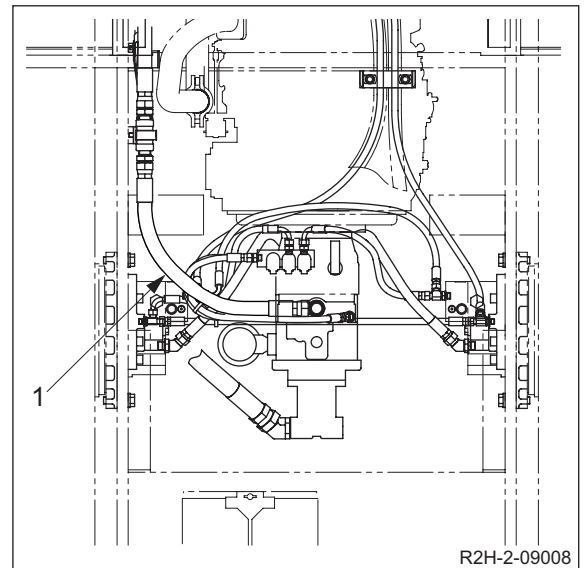

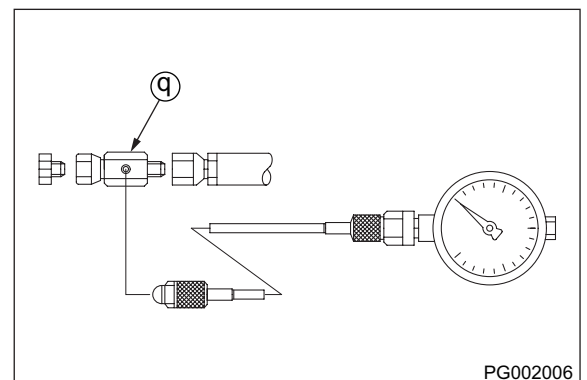

★ Allowable pump case pressure

: 0.3 MPa (44 psi) or less



9. MEASUREMENT OF PROPULSION MOTOR CASE PRESSURE

9-1. Measurement of Front Propulsion Motor



- Oil temperature during measurement : $50 \pm 5^{\circ}\text{C}$ ($122 \pm 41^{\circ}\text{F}$)
- ① Disconnect hose (1) and (2) from propulsion motor. Attach pressure gauge through adapter ① .
 - Hose (1) : Propulsion motor (F. R)
 - Hose (2) : Propulsion motor (F. L)
 - Adapter ① : G1/2
 - Pressure gauge : 0 to 5 MPa (0 to 725 psi)
- ② Set propulsion speed change switch to “” position.
- ③ Start the engine and set throttle lever to “Full” position.
- ④ Establish a condition in which machine propulsion load becomes maximal. (Pressure does not build up unless propulsion load is applied.)
- ⑤ With propulsion load at maximum, measure pressure when speed change switch is in “” and “” positions and F-R lever is in “neutral”, “forward”, and “reverse” positions, respectively.

★ Allowable motor case pressure

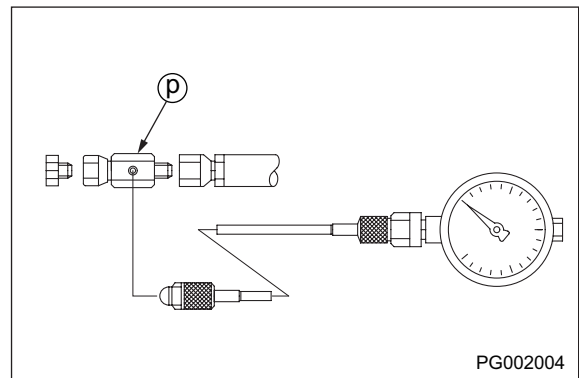
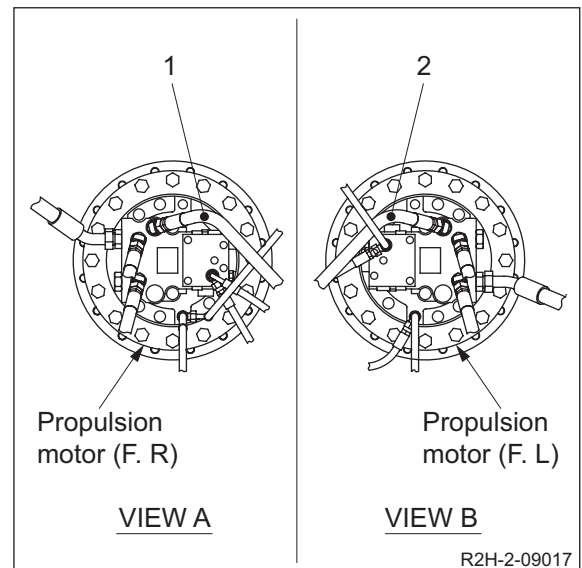
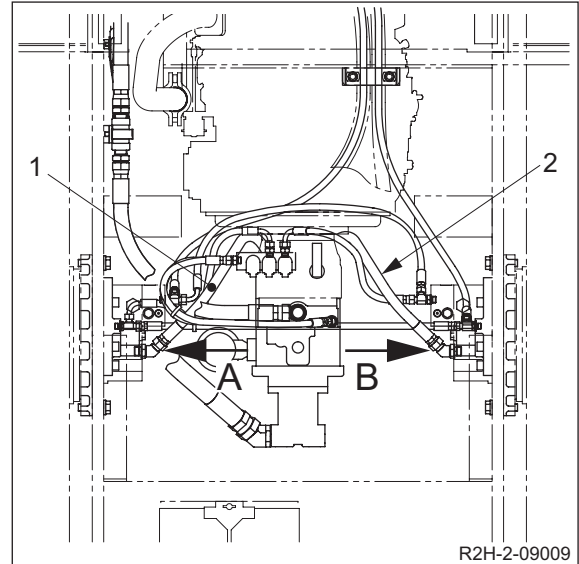
: 0.3 MPa (43.5 psi) or less



9-2. Measurement of Rear Propulsion Motor

- Oil temperature during measurement : $50 \pm 5^{\circ}\text{C}$ ($122 \pm 41^{\circ}\text{F}$)
- ① Remove plug from propulsion motor drain port (3). Attach pressure gauge with adapter ④ .
 - Adapter ④ : G1/2
 - Pressure gauge : 0 to 5 MPa (0 to 725 psi)
- ② Set propulsion speed change switch to “” position.
- ③ Start the engine and set throttle lever to “Full” position.
- ④ Establish a condition in which machine propulsion load becomes maximal. (Pressure does not build up unless propulsion load is applied.)
- ⑤ With propulsion load at maximum, measure pressure when speed change switch is in “” and “” positions and F-R lever is in “neutral”, “forward”, and “reverse” positions, respectively.

★ Allowable motor case pressure

: 0.3 MPa (43.5 psi) or less

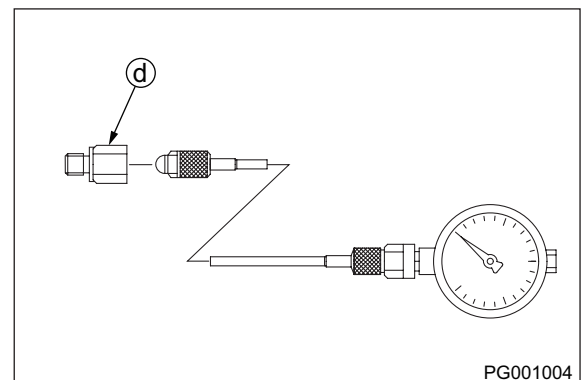
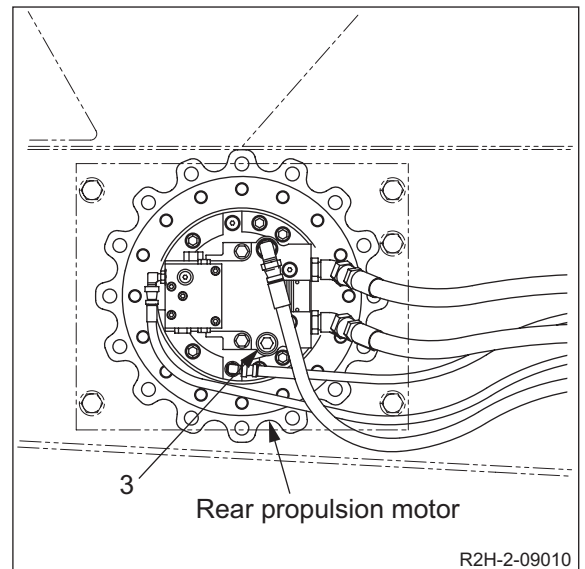

10. ADJUSTMENT OF THROTTLE LEVER LINKAGE

10-1. Adjustment

- If throttle lever linkage was replaced or maximum no-load rotational speed (minimum no-load rotational speed) deviates from standard value, make an adjustment in accordance with procedure described below.
- Make adjustment after amply warming up the engine.
 - ① Set throttle lever (3) to minimum no-load rotational speed position.
 - ② Attach control cable (4) to fuel injection pump's control lever (8).
 - ③ Start the engine.
 - ④ Loosen lock nut (2).
 - ⑤ Using stopper bolt (IDLE) (1), adjust so that standard minimum no-load rotational speed is achieved.

★ **Standard minimum no-load rotational speed**
: 1,000 ± 50 rpm

- ⑥ Set throttle lever (3) in maximum no-load rotational speed position.
- ⑦ Loosen lock nut (6).
- ⑧ Using stopper bolt (FULL) (5), adjust so that control lever (8) contacts the stopper (7).
- ⑨ Confirm that engine speed is within standard range.

★ **Standard maximum no-load rotational speed**
: 2,400 ± 50 rpm

- ⑩ Using lock nuts (2 and 6), firmly secure stopper bolts (1 and 5).

(NOTICE)

- If maximum no-load rotational speed is not in standard range even when control lever (8) is against the stopper (7), adjust injection nozzle, or repair or replace fuel injection pump.

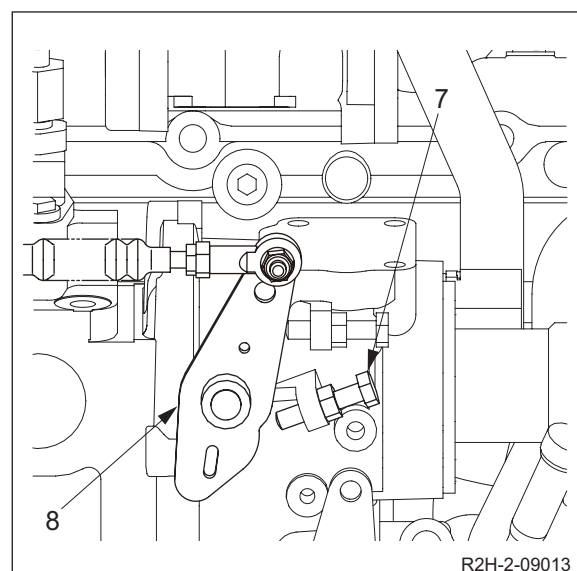
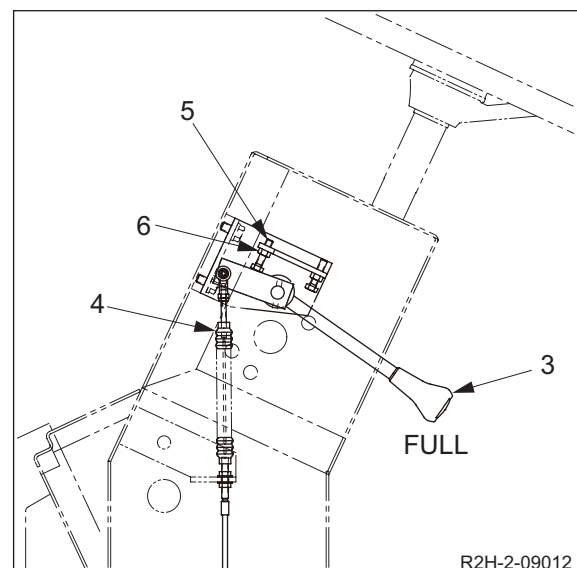
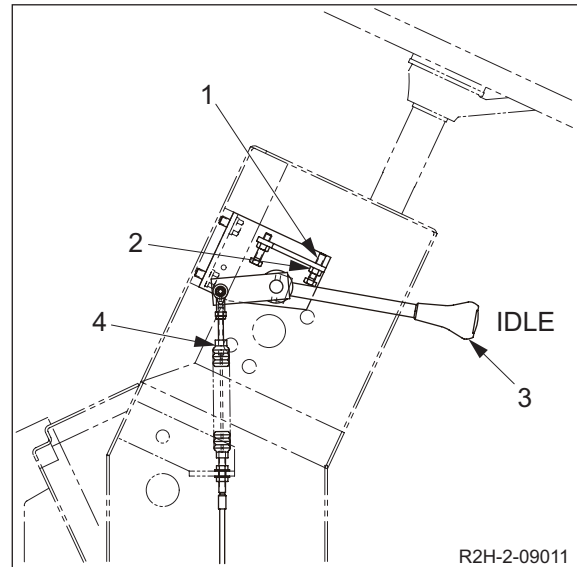

11. ADJUSTMENT OF F-R LEVER LINKAGE

11-1. Adjustment

- If F-R lever linkage was replaced, make an adjustment in accordance with procedure described below.
- Neutral position of F-R lever (1) and maximum stroke on forward-reverse side are positioned by notches.

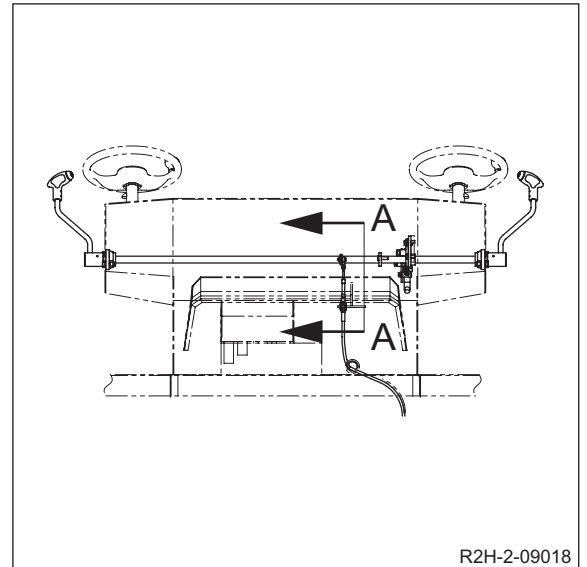

- ① Firmly secure F-R lever in neutral position.
- ② Firmly secure both ends of control cable (2).

★ Specified dimension of control cable ends
a : 170 mm (6.69 in.)

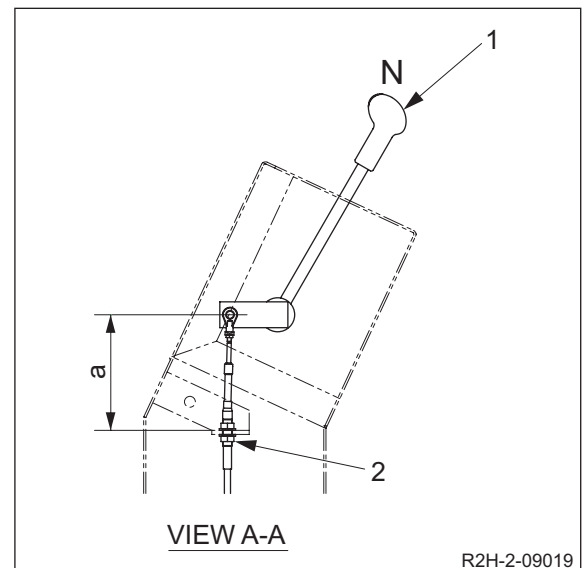

★ Specified dimension of control cable ends
b : 172 mm (6.77 in.)

- ③ Confirm stroke of control lever (3) on propulsion pump side.

★ Specified dimension of control lever
c : 22 mm (0.9 in.)

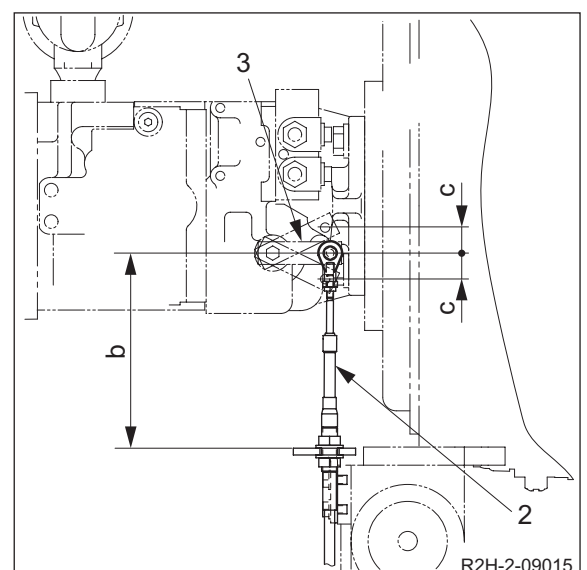

TROUBLESHOOTING

1. TROUBLESHOOTING

1-1. Safety Precautions for Troubleshooting

WARNING

Unexpected machine movement may cause a serious accident. When inspecting the machine while the engine is running, always follow the instructions below.

- Park the machine on level, flat ground.
- Apply the parking brake.
- Set chocks in front and behind each drum or tire.
- Make sure that service personnel are given the appropriate information at the appropriate time.
- Make sure that no one can enter any hazardous area.

CAUTION

Do not work on the hydraulic system while the engine is running and the system is hot and under pressure. Do not disconnect hydraulic hoses or fittings until the system has cooled and pressure has been properly relieved.

Before removing any plugs from the pressure measurement ports, always release any residual pressure from the piping and open the cap of the fluid tank to release and pressure.

WARNING

Inadvertent starting the engine may cause a serious accident.

When inspecting the engine, make sure to exchange the appropriate cues and hand signal with the person at the operator station to avoid any accidents.

CAUTION

Before inspecting inside of the engine compartment, always stop the engine.

Contact with the fan, V-belt or exhaust system parts while the engine is running may cause serious injury.

1-2. Important Information for Troubleshooting

Before conducting troubleshooting, it is important to carefully read the operation manual and workshop manual and understand the electric circuits for each component as well as the structure and function of each system. Sufficient knowledge of the systems will enable you to identify a possible cause much faster. A fault or problem may seem to be related to many different factors. To identify the true cause, some experience is needed. To perform the appropriate troubleshooting, it is important to learn not only the normal operations of the systems but also the possible symptoms that may occur when an abnormal condition is present.

This chapter explains the possible causes and remedies for likely incidents taken from past experience.

1-3. Before Starting

The information in this section is provided to assist the troubleshooter in understanding the systems and quickly determine the causes when operating abnormalities occur.

The following steps are recommended:

1. If not familiar with the machine, study the Operator's Manual and this Shop Manual.
2. Check with the operator for full details of the trouble, ask questions.
3. Verify the trouble by warming up the machine and operating it. Check the problem yourself.
4. Identify the problem with either a mechanical, hydraulic or electrical system source.
5. Isolate the problem to a particular component or circuit.
6. Eliminate the simplest or easiest to check possibilities first to prevent unnecessary disassembly of components.
7. Following repair or replacement of any parts, perform operational tests to verify that the problem has been eliminated and the performance of all the systems is normal.

1-4. Wire Color Code and Number

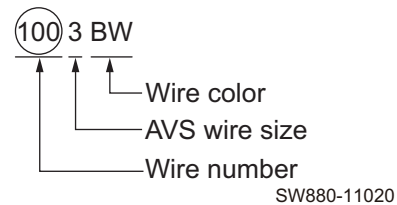
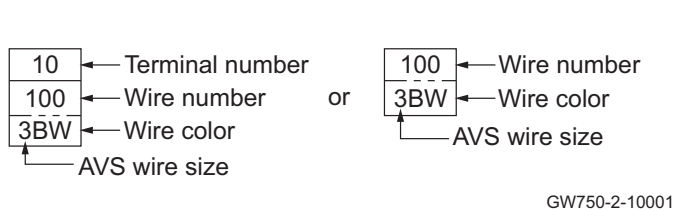

- The arrangement of connector terminals shown above is that of connecting surfaces on the connector side.

- Wire number, wire size and wire color are shown as above in electrical circuit diagrams.

B	Black	BW	Black/White stripe	BY	Black/Yellow stripe	BR	Black/Red stripe	BG	Black/Green stripe	BL	Black/Blue stripe			O	Orange	YO	Yellow/Orange stripe
W	White	WR	White/Red stripe	WB	White/Black stripe	WL	White/Blue stripe	WY	White/Yellow stripe	WG	White/Green stripe					LO	Blue/Orange stripe
R	Red	RW	Red/White stripe	RB	Red/Black stripe	RY	Red/Yellow stripe	RG	Red/Green stripe	RL	Red/Blue stripe					GO	Green/Orange stripe
G	Green	GW	Green/White stripe	GR	Green/Red stripe	GY	Green/Yellow stripe	GB	Green/Black stripe	GL	Green/Blue stripe			Gy	Gray	GyR	Gray/Red stripe
Y	Yellow	YR	Yellow/Red stripe	YB	Yellow/Black stripe	YG	Yellow/Green stripe	YL	Yellow/Blue stripe	YW	Yellow/White stripe					GyL	Gray/Blue stripe
Br	Brown	BrW	Brown/White stripe	BrR	Brown/Red stripe	BrY	Brown/Yellow stripe	BrB	Brown/Black stripe	BrG	Brown/Green stripe	BrL	Brown/Blue stripe	Sb	Sky blue		
L	Blue	LW	Blue/White stripe	LR	Blue/Red stripe	LY	Blue/Yellow stripe	LB	Blue/Black stripe	LG	Blue/Green stripe			P	Pink		
Lg	Light green	LgR	Light green/Red stripe	LgY	Light green/Yellow stripe	LgB	Light green/Black stripe	LgW	Light green/White stripe	LgL	Light green/Blue stripe			Pu	Purple	PB	Pink/Black stripe

2. ELECTRICAL SYSTEM TROUBLESHOOTING

2-1. When Performing Electrical System Fault Diagnosis

⚠ WARNING

Be very careful because equipment can return to normal during an inspection and suddenly operate properly when a failure occurs due to a faulty contact or other such cause.

2-1-1. Precautions to take during electrical circuit fault diagnosis

- When disconnecting or connecting a connector, be sure to turn the power supply OFF. (Electronic control parts such as the engine control unit, in particular, could be damaged internally.)
- Since connectors are not numbered, be sure to affix alignment marks so that you can restore them to their original condition.
- Before making a diagnosis, check related connectors for faulty connections. (Check by disconnecting and reconnecting related connectors several times.)
- Before proceeding to the next step, be sure to return the disconnected connectors to their original condition.
- When diagnosing a circuit (measuring the voltage, resistance, continuity and current), move related wiring and connectors several times, and check whether the tester's numerical values change. (If values change, faulty contact in the circuit is possible.)
- Do not ground the circuit of the control unit or apply voltage to it unless otherwise specified.

2-1-2. Inspection procedures using a tester

Some of the various inspection procedures are presented here for reference, using a sample circuit below.

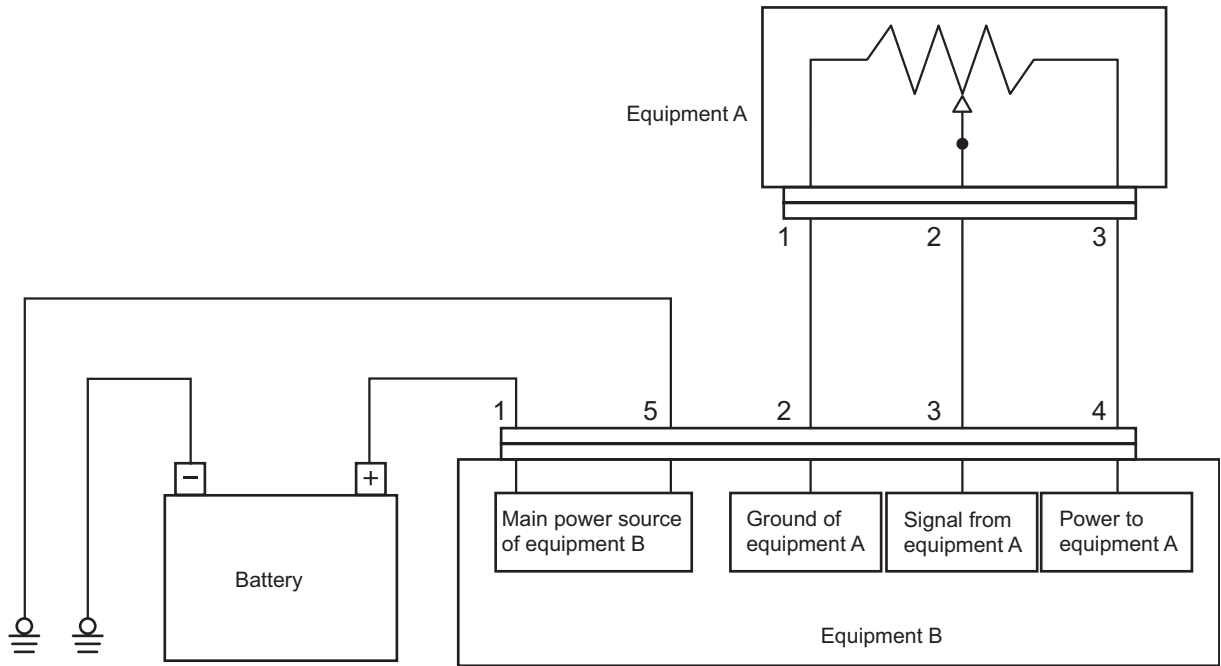

GW750-2-10003

1) Measuring resistance using tester

1-1) Measuring resistance of equipment A (measuring resistance between terminals 1 and 3)

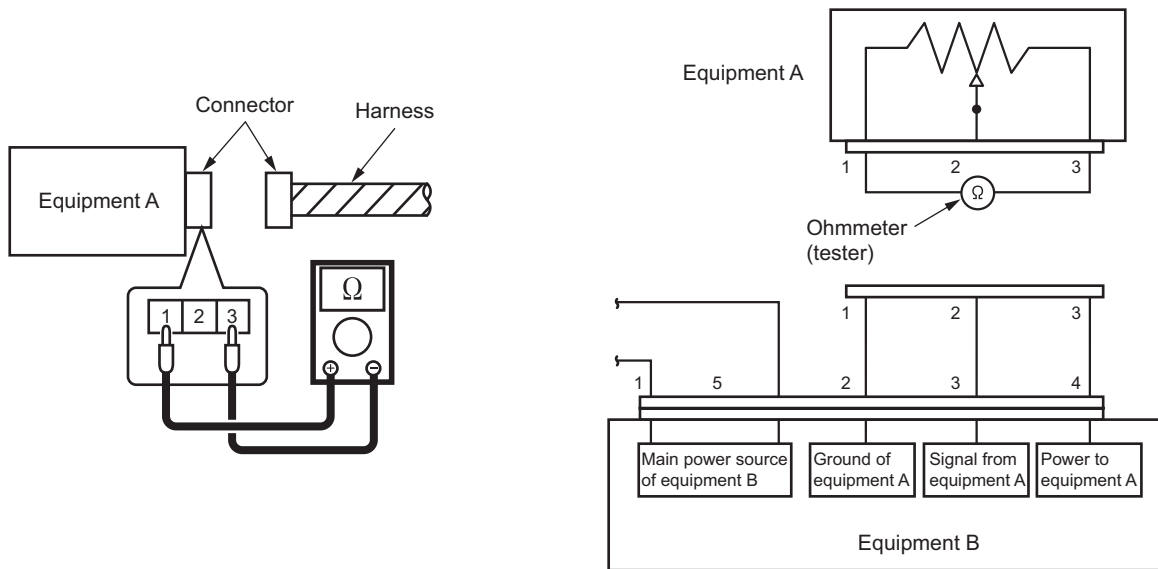

GW750-2-10004

Inspection procedure

- ① Disconnect the connector of equipment A.
- ② Connect the test probe (+) to connector terminal 1 of equipment A and the test probe (-) to connector terminal 3 of equipment A and measure the resistance. At this time, reversing the connector terminals between the probes (+) and (-) does not make any difference in the measurement.

- 1-2) Measuring resistance of harness (measuring resistance between terminal 1 of equipment A and terminal 2 of equipment B)

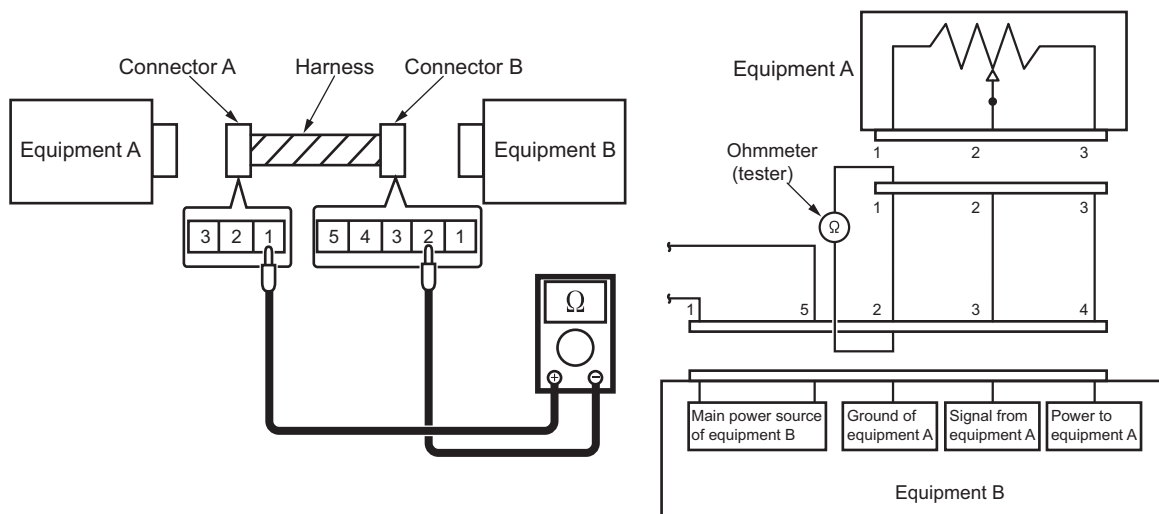

GW750-2-10005

Inspection procedure

- ① Disconnect the connectors of equipment A and equipment B.
- ② Connect the test probe (+) to connector terminal 1 of equipment A and the test probe (-) to connector terminal 2 of equipment B and measure the resistance. At this time, reversing the connector terminals between the probes (+) and (-) does not make any difference in the measurement.

Criteria for harness defects

When there is no abnormality in the harness: Less than 10 Ω (measured value)

If there is any abnormality in the harness such as broken wire: 10 Ω or higher (measured value)

- 1-3) Measuring resistance of grounding wire (measuring resistance between terminal 5 of equipment B and ground)

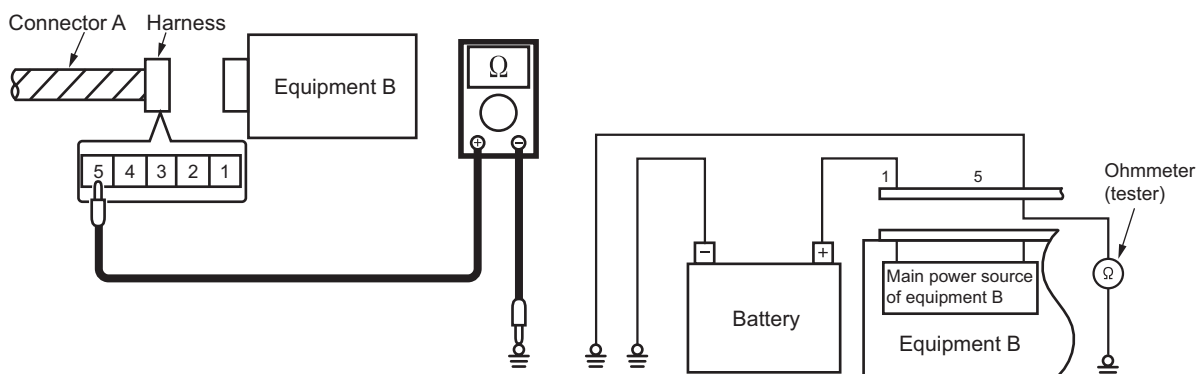

GW750-2-10006

Inspection procedure

- ① Disconnect the connector of equipment B.
- ② Connect the test probe (+) to connector terminal 5 of equipment B and the test probe (-) to a machine ground point (the bolt fastening the ground terminal or an unpainted portion on the body) and measure the resistance. At this time, reversing the connector terminals between the probes (+) and (-) does not make any difference in the measurement.

(NOTICE)

- When measuring the resistance, connect the test probes to both ends of the portion to be measured. Make also sure that no voltage is applied to the portion to be measured.
- When measuring the internal resistance of equipment, be sure first to disconnect all harnesses from the equipment.
- When measuring the resistance of a harness, disconnect the equipment connected to both ends of the harness.

- 2) Measuring voltage and current flowing using tester

TROUBLESHOOTING

2-1) Measuring voltage of equipment A (measuring voltage between terminals 1 and 3)

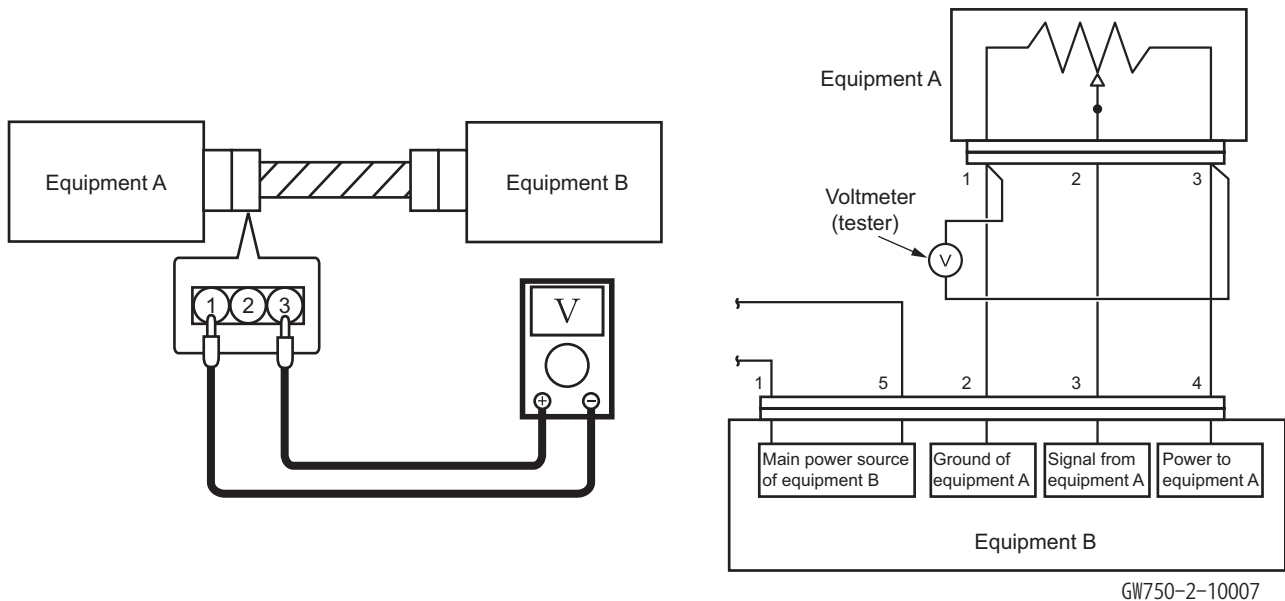

Inspection procedure

- ① Connect the connectors of equipment A and that of equipment B.
- ② Connect the test probe (+) to connector terminal 3 of equipment A and the test probe (-) to connector terminal 1 of equipment A and measure the voltage. Note that reversing the connector terminals between the probes (+) and (-) changes the result of the measurement. Be sure to connect the probe (+) to the power source side and the probe (-) to the ground side.

① Measurement using a test harness

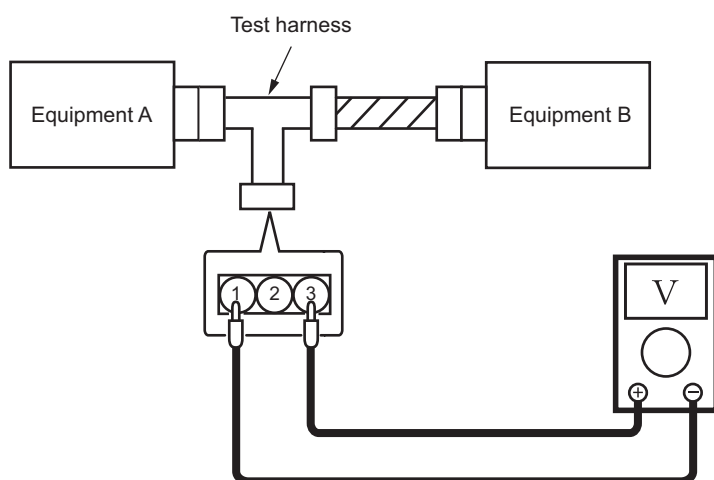

② Measurement from the backside of connector

③ Measurement on a lead cable

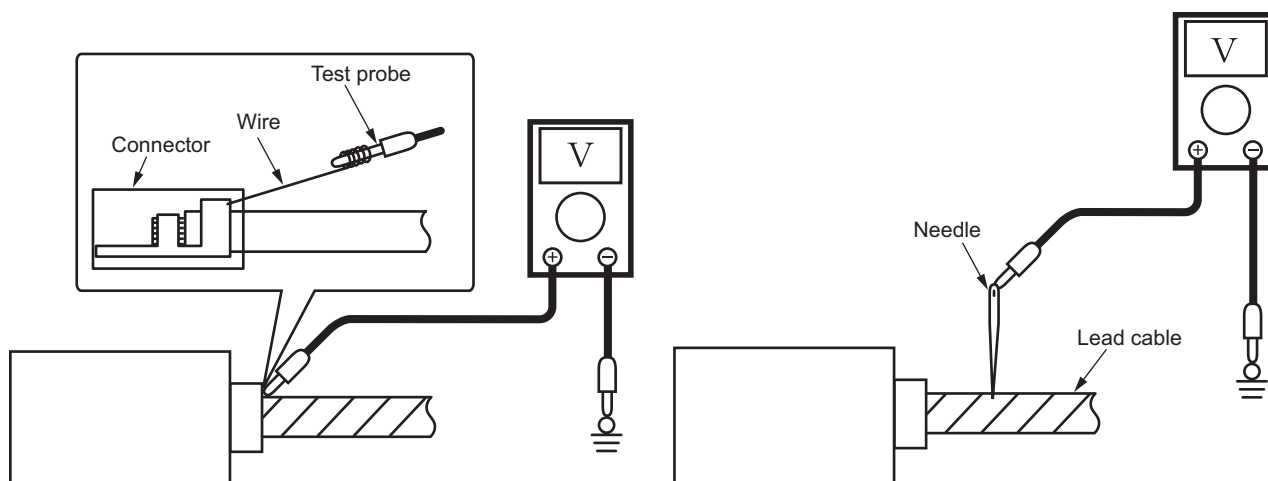

GW750-2-10002

Measurement method

For measurement of voltage, connect the tester probes in parallel to the portion to be measured. Because the voltage can be measured only when the connector is connected in position, contact the tester probes to the terminals without disconnecting the connector. The following methods are available:

① Measurement using a test harness

- Prepare the test harness for the measurement.

② Measurement from the backside of connector

- Insert a wire from the backside of the connector.

③ Measurement on a lead cable

- Remove the bundling tape from the harness to separate each cable, and stick the needle into the relevant cable.

(NOTICE)

- Except for preparing the test harness, proper protection must be made after the measurement to prevent corrosion in the connector terminals or harnesses.

TROUBLESHOOTING

- 2-2) Measuring current flowing from equipment B to equipment A
(measuring current between terminal 2 of equipment B and terminal 1 of equipment A)

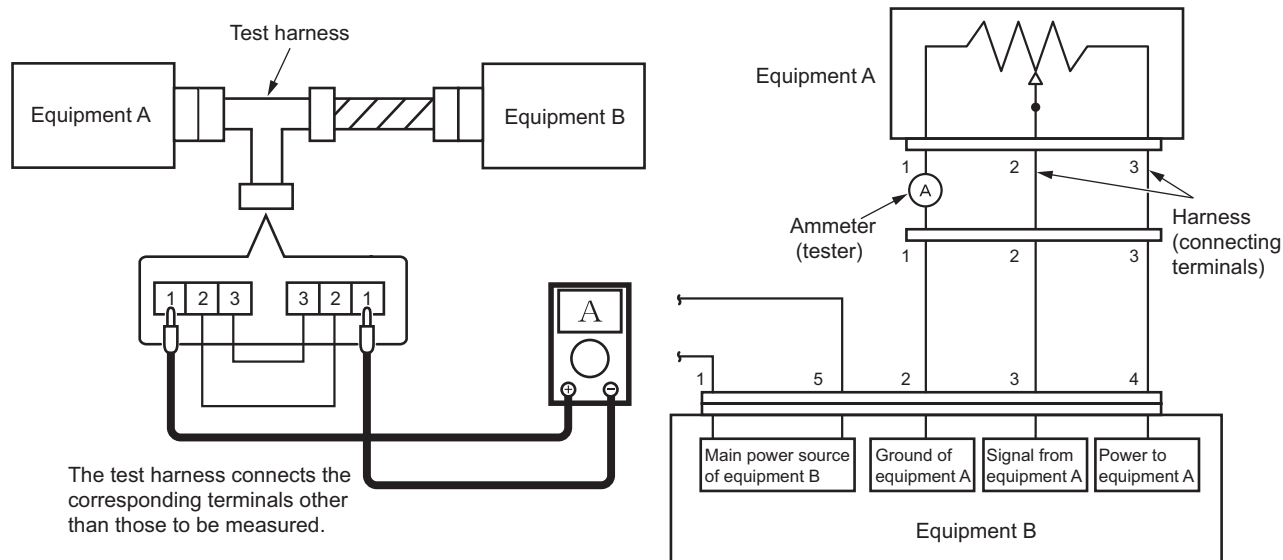

Inspection procedure

- ① Disconnect the connector of equipment A and connect the test harness.
- ② Connect the test probe (+) to connector terminal 1 (harness side) of equipment A and the test probe (-) to connector terminal 1 (equipment side) of equipment A and measure the current. Note that reversing the connector terminals between the probes (+) and (-) changes the result of the measurement. Be sure to connect the probe (+) to the power source side and the probe (-) to the ground side.

Measurement method

When measuring the current, connect the tester in series to the portion to be measured. Because the current cannot be measured when the connector is connected in position, disconnect the connector to allow the test probe to connect between the terminals.

2-1-3. Inspection of electrical system

Operate the applicable switches and turn the relays ON and OFF. Ultimately, if the solenoid valve operates (makes a sound) and the pump runs, the electrical system is OK.

If there is a failure (fault), narrow the range of the inspection to the six broad steps described below.

1) Ground inspection

- Check for disconnected or loose ground. If rust or corrosion is present (which can cause faulty contact), remove the rust.

2) Fuse inspection

2-1) Check for blown fuses, disconnections and corrosion. (A fatigue open circuit cannot be identified visually. Use a tester for checking.)

2-2) If a fuse is blown

Check whether a pump or valve (that is supposed to be protected by a blown fuse) burned, and whether there is a burning odor.

Especially if the pump and valve are not burned, check the harness for signs of burning. If it is burned, replace it.

If a fuse is blown and a relay along the pathway has failed, replace it. And if there is a timer, replace the timer, too. If a switch visually appears to be unsatisfactory (burned, melted, etc.) even though it operates, replace it.

- Simply replacing a fuse may not eliminate the true cause of a problem, and over current may flow again. Also, if over current secondarily causes an electrical path to fail (such as a wiring meltdown inside a solenoid valve), current will not flow. Thus, a fuse may not be blown out, but it also will not operate. If you do not know the location of burning or of an odor, investigate as described follows.

2-3) How to find cause of failure when fuse blown is reproduced

- ① Turn the starter switch OFF, and remove the connector from the load (valve, pump).
- ② Referring to the circuit diagram, remove electrical parts that are connected to the circuit, such as relays, timers and diodes.
- ③ Turn the starter switch ON, and see whether the conditions can be reproduced (fuse is blown).
- ④ If a fuse is blown, a part such as a relay may have caused a short between the previous harness and ground (machine body). (Replace the harness.) If the conditions are not reproduced, check for signs of burning (odor) on the removed electrical parts.
- ⑤ If there is no problem, turn the starter switch OFF and reattach the parts.
- ⑥ Turn the starter switch ON and try again.
- ⑦ If a fuse is blown with this action, the problem was caused by a short between the harness and ground (machine body) that followed the attached electrical part. (Replace the harness.)
- ⑧ If the conditions are not reproduced, turn the starter switch OFF, and connect the loads (valve and pump) one at a time. Turn the starter switch ON and try again to see whether the fuse blown is reproduced.
- ⑨ If the fuse blown is reproduced, whatever was added at that time (including a harness added electrically) will be the cause of the failure.
 - Even if the fuse is not blown and the valve or pump is not burned, the valve or pump may be damaged electrically and may not operate. There may simply be a disconnection in the interior or an abnormal heat-up.
 - Even if the fuse is not blown, abnormal heat-up (hot enough to cause burns if touched) may occur if a relay, timer, diode or other semiconductor fails.

TROUBLESHOOTING

3) Connector inspection

- Is a connector disconnected or loose?
- Check that pins are not snapped or corroded.
- If faulty contact is suspected

Turn the starter switch OFF. Then disconnect and check the connectors (including relay and switch sockets).

If the terminal has no luster, faulty contact due to oxidation can be suspected. Therefore, polish the terminal by inserting and removing the connector (relay, switch) repeatedly at least five times. (Luster will return.)

4) Relay inspection (Check ON/OFF operation by sound.)

- Conduct without running the engine. (If you run the engine, you cannot hear the sound of operation.)

Sound heard : A relay failure occurred.

No sound heard : Using a tester, check the harness.

Sound heard : A relay failure occurred.

Still no sound : Using a tester, check the harness.

Continuity : Turn the starter switch OFF temporarily, disconnect the relay and check for continuity between the harness-side grounding terminal (color: black) and machine body ground. (If there is none, replace the harness.)

Voltage : With the relay disconnected, turn the starter switch ON and turn the operating switch ON. 24 V (or 12 V) (between machine body ground) should not reach the relay coil input terminal. Confirm this. Identify the location (section) to which 24 V (or 12 V) reaches. Then replace the harness or take other action.

5) Solenoid valve inspection (Check ON/OFF operation by sound.)

- Conduct without running the engine. (If you run the engine, you cannot hear the sound of operation.)

Sound heard : The electrical system is normal.

No sound heard : Check with a tester.

Continuity : ① Turn the starter switch OFF temporarily, disconnect the connector and check for continuity between the harness-side grounding terminal (color: black) and machine body ground. (If there is none, replace the harness.)

: ② Is the solenoid valve coil burnt?

(Turn the starter switch OFF, disconnect the connector and check the resistance between the solenoid valve terminals.)

Voltage : With the connector disconnected, turn the starter switch ON and check whether 24 V (or 12 V) exists between the harness-side connector and machine body ground.

If YES : Replace the valve.

If NO : Investigate and identify the location (section) to which 24 V (or 12 V) reaches. Then replace the harness or take other action.

6) Harness check

- If an incomplete disconnection inside the harness is suspected, wiggle (move) the harness during the relay inspection and solenoid valve inspection to see whether the relay (valve) operates incorrectly.
- Check for burned areas of the harness.
- Turn the starter switch OFF, disconnect the connector and check the continuity, referring to the circuit diagram and wiring coloring.

Fig.: 2-2-1

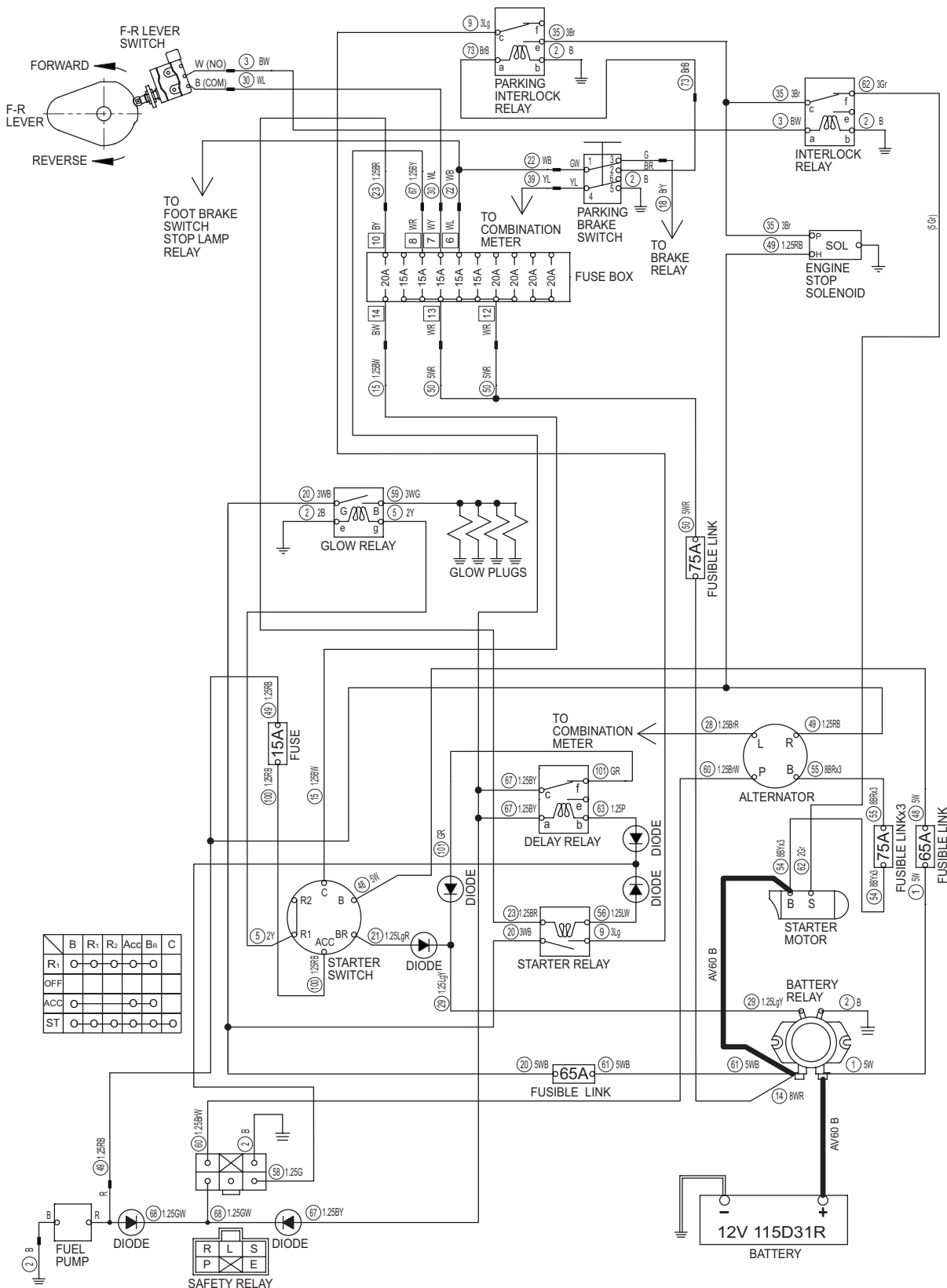

2-2. Engine

Check following items before troubleshooting.

- No blown fuses and power is applied up to fuses.
- Check any ground circuit which belongs to components to be checked.

2-2-1. Engine will not start (Starter motor does not run) 1/3

- F-R lever must be in neutral.
- Parking brake switch must be applied.

Reference Fig.: 2-2-1

Check point	Check/Cause	Action
1. Battery	<ul style="list-style-type: none"> • Measure battery voltage or specific gravity. Standard voltage : 12 V or more Standard gravity : 1.26 or more • If value is below standard, battery capacity is insufficient. 	Charge or replace battery.
2. Starter Switch	<ul style="list-style-type: none"> • Check continuity between O-O according to starter switch connection table. Switch is OK if there is continuity between connection O-O. • If there is no continuity, starter switch is faulty. 	Replace starter switch.
3. Starter Motor	<p>(1) When starter switch is ON, measure voltage between starter motor terminal B and chassis ground. Standard voltage : 12 V or more</p> <p>(2) When starter switch is START, measure voltage between starter motor terminal S and chassis ground. Standard voltage : 12 V or more</p> <ul style="list-style-type: none"> • If starter motor does not run even though above items (1) and (2) are OK, starter motor is faulty. 	Replace starter motor.
4. Safety Relay	<p>(1) When starter switch is ON, measure voltage between safety relay terminal R inlet wire GW and chassis ground. Standard voltage : 12 V or more</p> <p>(2) When starter switch is START, measure voltage between safety relay terminal S inlet wire G and chassis ground. Standard voltage : 12 V or more</p> <p>(3) Check that no abnormality is found in safety relay ground terminal.</p> <ul style="list-style-type: none"> • If above items (1), (2) and (3) are OK and starter motor does not run, safety relay is faulty. 	Replace safety relay.
5. Battery Relay	<p>(1) When starter switch is OFF, measure voltage between battery relay primary terminal and chassis ground. Standard voltage : 12 V or more</p> <p>(2) When starter switch is ON, measure voltage between battery relay coil terminal inlet wire LgY and coil ground terminal wire B. Standard voltage : 12 V or more</p> <p>(3) When starter switch is ON, measure voltage between battery relay secondary terminal and chassis ground. Standard voltage : 12 V or more</p> <ul style="list-style-type: none"> • If above items (1) and (2) are OK and item (3) is NG, battery relay is faulty. 	Replace battery relay.

Fig.: 2-2-1

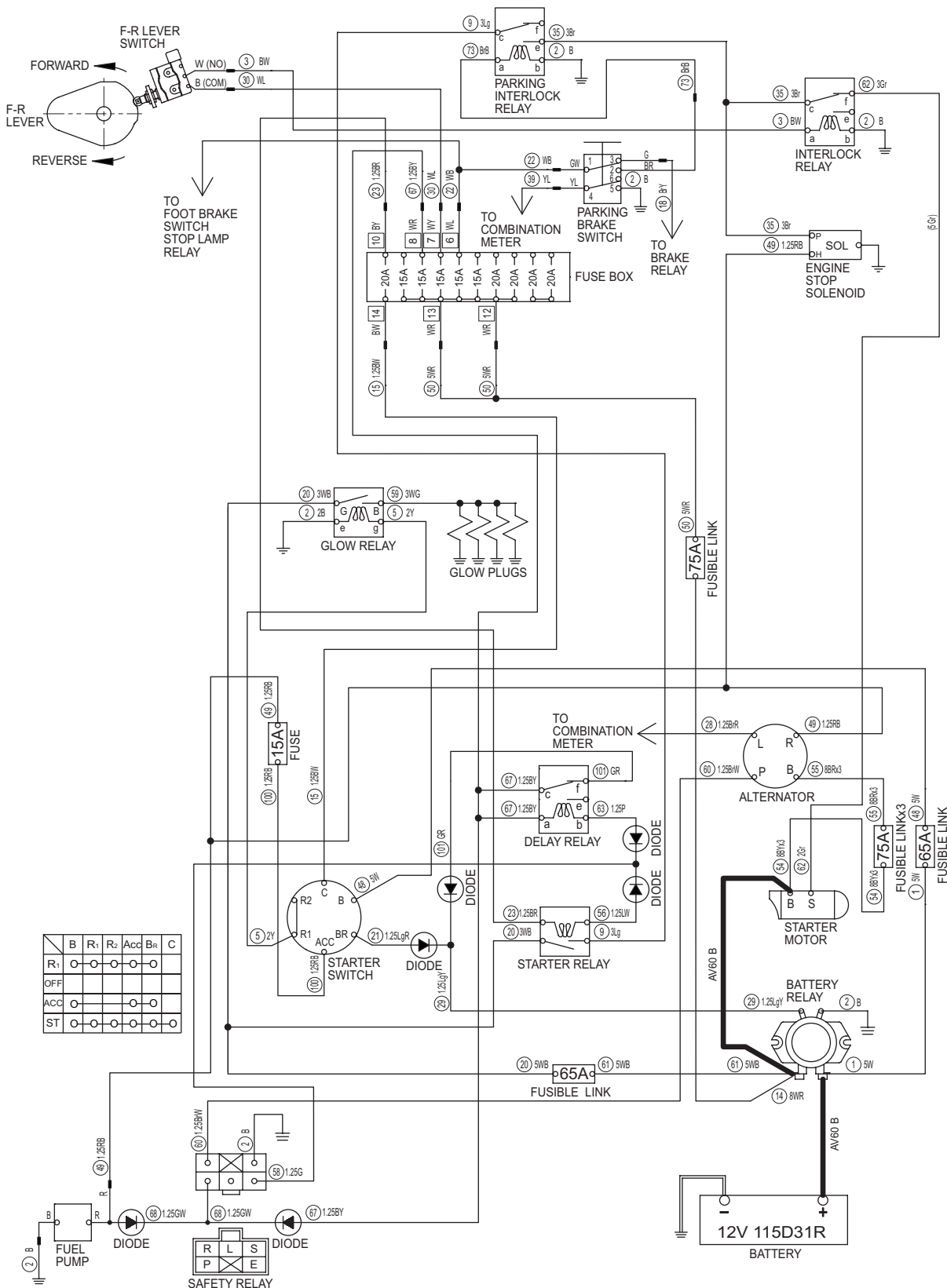

2-2-1. Engine will not start (Starter motor does not run) 2/3

- F-R lever must be in neutral.
- Parking brake switch must be applied.

Reference Fig.: 2-2-1

Check point	Check/Cause	Action
6. F-R Lever Switch	<p>(1) When starter switch is ON, measure voltage between F-R lever switch terminal COM inlet wire WL and chassis ground. Standard voltage : 12 V or more</p> <p>(2) When starter switch is ON, measure voltage between F-R lever switch terminal NO outlet wire BW and chassis ground. There is no electricity in normal condition.</p> <ul style="list-style-type: none"> • If above item (1) is OK and item (2) is NG, F-R lever switch is faulty. 	Replace F-R lever switch.
7. Interlock Relay	<p>(1) When starter switch is ON, measure voltage between interlock relay terminal a inlet wire BW and chassis ground. There is no electricity in normal condition.</p> <p>(2) When starter switch is START, measure voltage between interlock relay terminal c inlet wire Br and chassis ground. Standard voltage : 12 V or more</p> <p>(3) When starter switch is START, measure voltage between interlock relay terminal f outlet wire Gr and chassis ground. Standard voltage : 12 V or more</p> <ul style="list-style-type: none"> • If above items (1) and (2) are OK and item (3) is NG, interlock relay is faulty. 	Replace interlock relay.
8. Parking Interlock Relay	<p>(1) When starter switch is ON, measure voltage between parking interlock relay terminal a inlet wire BrB and chassis ground. Standard voltage : 12 V or more</p> <p>(2) When starter switch is START, measure voltage between parking interlock relay terminal c inlet wire Lg and chassis ground. Standard voltage : 12 V or more</p> <p>(3) When starter switch is START, measure voltage between parking interlock relay terminal e inlet wire Br and chassis ground. Standard voltage : 12 V or more</p> <ul style="list-style-type: none"> • If above items (1) and (2) are OK and item (3) is NG, parking interlock relay is faulty. 	Replace parking interlock relay.

Fig.: 2-2-1

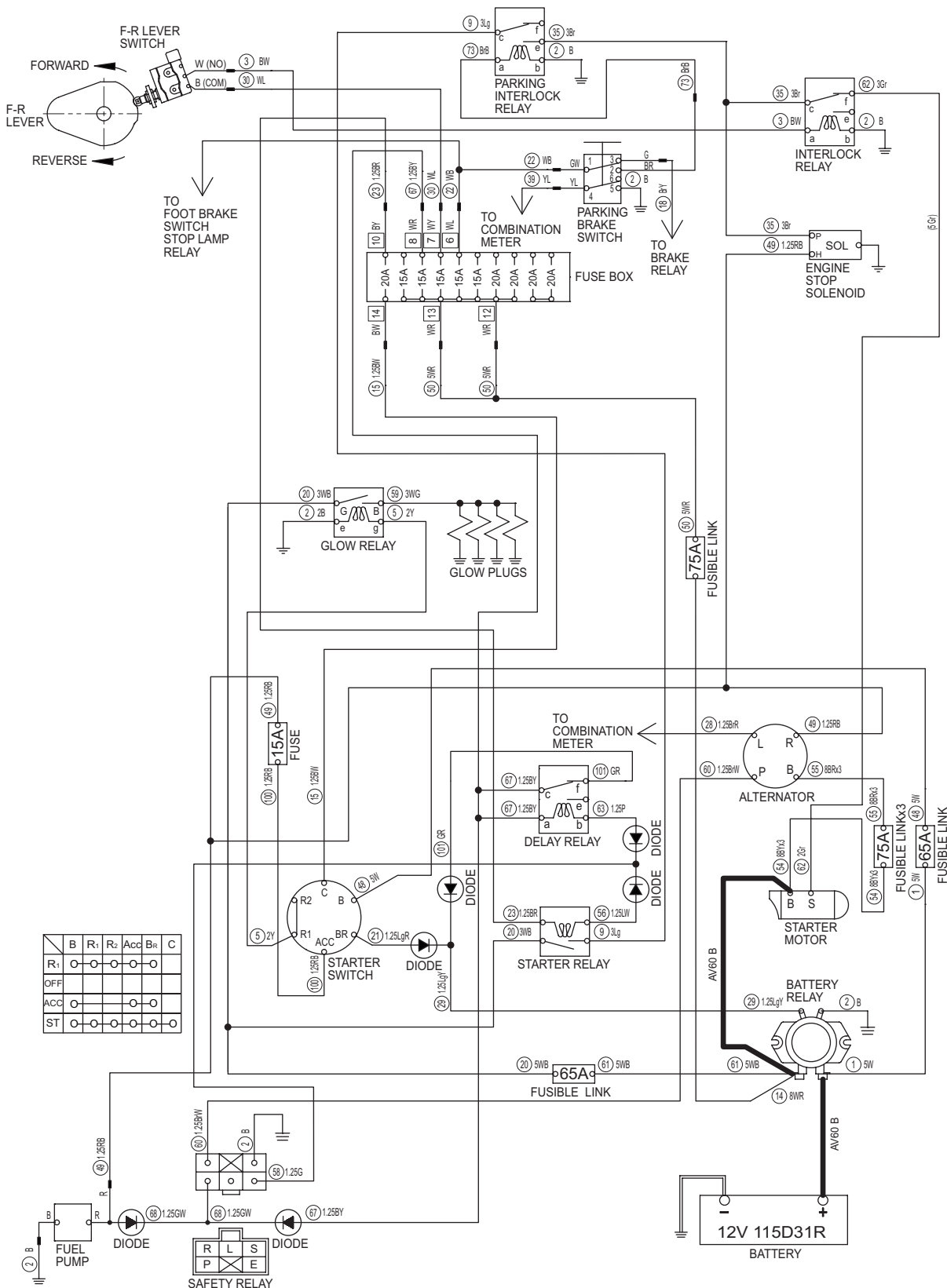

2-2-1. Engine will not start (Starter motor does not run) 3/3

- F-R lever must be in neutral.
- Parking brake switch must be applied.

Reference Fig.: 2-2-1

Check point	Check/Cause	Action
9. Starter Relay	<p>(1) When starter switch is ON, measure voltage between starter relay terminal inlet wire WB and chassis ground. Standard voltage : 12 V or more</p> <p>(2) When starter switch is START, measure voltage between starter relay terminal inlet wire BR and chassis ground. Standard voltage : 12 V or more</p> <p>(3) When starter switch is START, measure voltage between starter relay terminal outlet wire Lg and chassis ground. Standard voltage : 12 V or more</p> <ul style="list-style-type: none"> • If above items (1) and (2) are OK and item (3) is NG, starter relay is faulty. 	Replace starter relay.
10. Parking Brake Switch	<p>(1) When starter switch is ON, measure voltage between parking brake switch terminal 1 inlet wire GW and chassis ground. Standard voltage : 12 V or more</p> <p>(2) When starter switch is ON, measure voltage between parking brake switch terminal 2 outlet wire BR and chassis ground. Standard voltage : 12 V or more</p> <ul style="list-style-type: none"> • If above item (1) is OK and item (2) is NG, parking brake switch is faulty. 	Replace parking brake switch.
11. Harness Connecting Between Terminals	<ul style="list-style-type: none"> • Measure resistance of harness connecting between terminals. Standard resistance : 10 Ω or less • If resistance is abnormal, harness is faulty. 	Repair or replace harness.

Fig.: 2-2-1

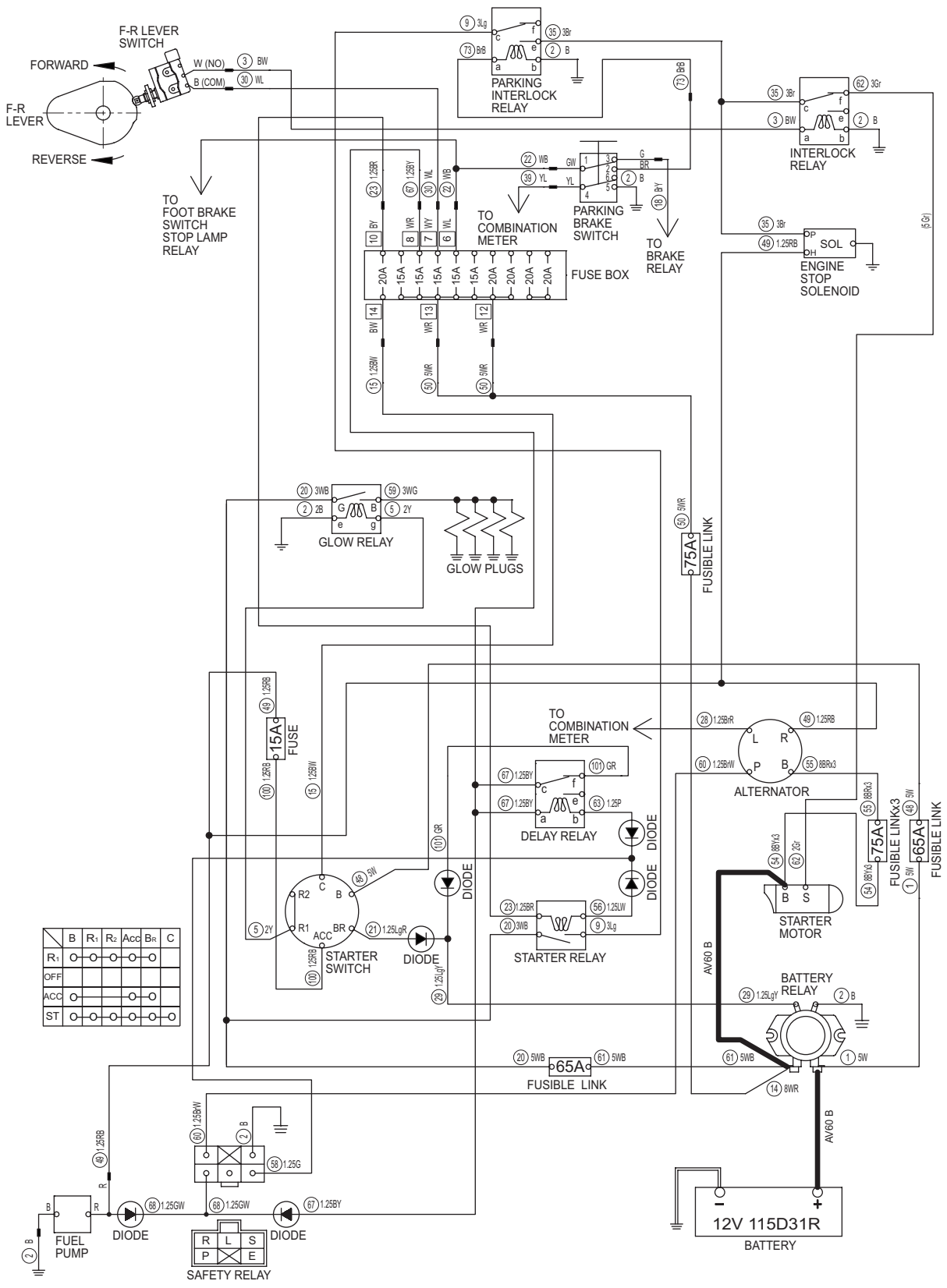

2-2-2. Engine will not start (But starter motor runs)

- In case of engine will not start while starter motor runs, generally trouble is caused by that fuel is not supplied, supply amount of fuel is extremely low, or selection of fuel is not appropriate.
- Check that fuel is supplied to inlet of fuel pump.

Reference Fig.: 2-2-1

Check point	Check/Cause	Action
1. Fuel Pump	<ul style="list-style-type: none"> • When starter switch is ON, measure voltage between fuel pump terminal R inlet wire RB and chassis ground. Standard voltage : 12 V or more • If above item is OK and fuel pump does not operate, fuel pump is faulty. 	Repair or replace fuel pump.
2. Engine Stop Solenoid	<p>(1) When starter switch is ON, measure voltage between engine stop solenoid terminal H inlet wire RB and chassis ground. Standard voltage : 12 V or more</p> <p>(2) When starter switch is START, measure voltage between engine stop solenoid terminal P inlet wire Br and chassis ground. Standard voltage : 12 V or more</p> <ul style="list-style-type: none"> • If above items (1) and (2) are OK and engine does not start, engine stop solenoid is faulty. 	Replace engine stop solenoid.
3. Harness Connecting Between Terminals	<ul style="list-style-type: none"> • Measure resistance of harness connecting between terminals. Standard resistance: 10 Ω or less • If resistance is abnormal, harness is faulty. 	Repair or replace harness.

2-2-3. Engine does not stop running

Reference Fig.: 2-2-1

Check point	Check/Cause	Action
1. Engine Stop Solenoid	<p>(1) When starter switch is OFF, measure voltage between engine stop solenoid terminal H inlet wire RB and chassis ground. There is no electricity in normal condition.</p> <p>(2) When starter switch is OFF, measure voltage between engine stop solenoid terminal P inlet wire Br and chassis ground. There is no electricity in normal condition.</p> <ul style="list-style-type: none"> • If above items (1) and (2) are OK and engine dose not stop running after starting engine, engine stop solenoid is faulty. 	Replace engine stop solenoid.
2. Harness Connecting Between Terminals	<ul style="list-style-type: none"> • Measure resistance of harness connecting between terminals. Standard resistance: 10 Ω or less • If resistance is abnormal, harness is faulty. 	Repair or replace harness.

Fig.: 2-2-1

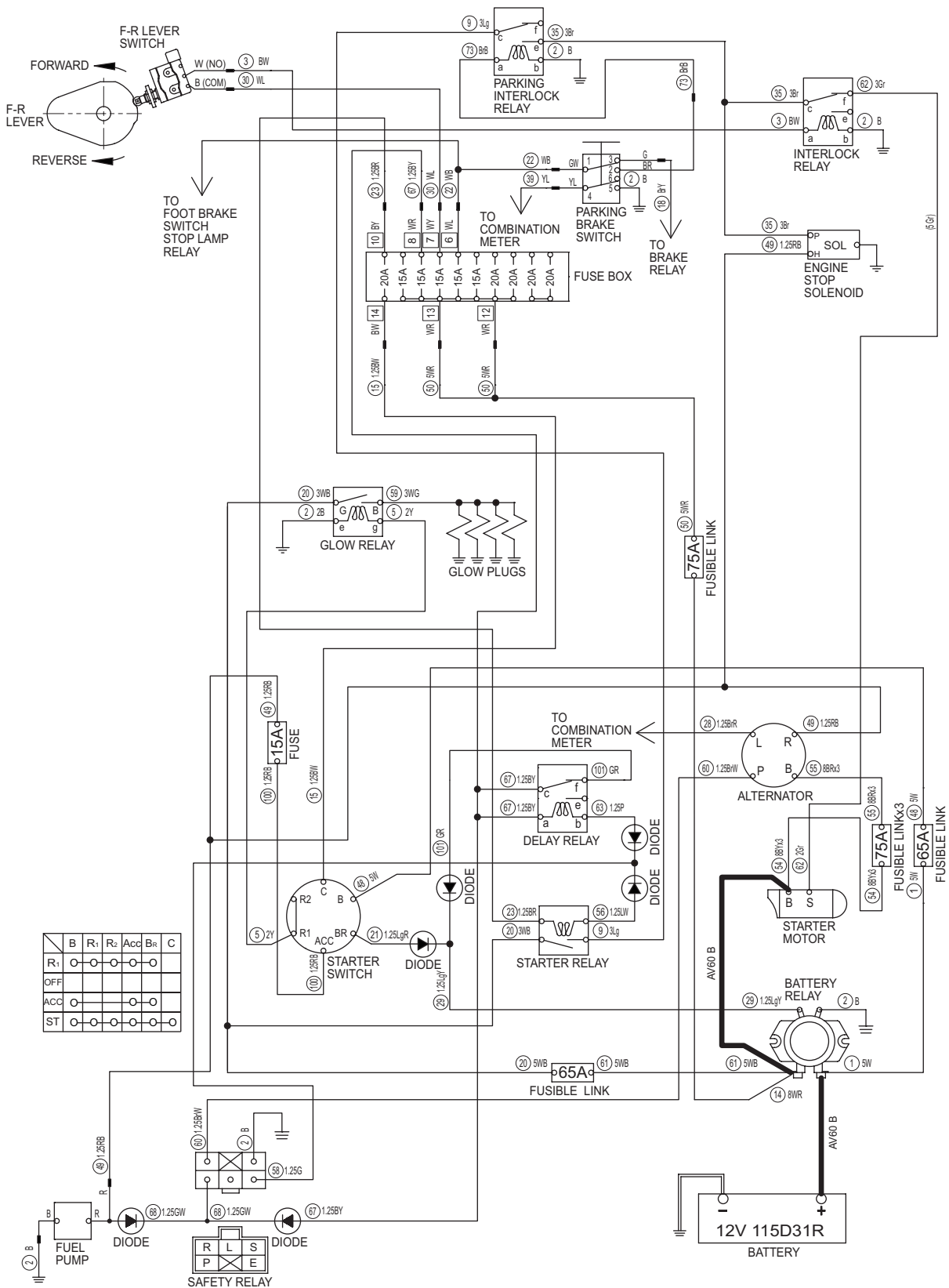

2-2-4. No charging

Reference Fig.: 2-2-1

Check point	Check/Cause	Action
1. Alternator	<ul style="list-style-type: none"> • After starting engine, measure voltage between alternator terminal B wire BR and chassis ground. Standard voltage: At least intermediate engine speed, 14 V or more • If voltage is lower than standard, alternator is faulty. • If voltage is normal and battery is not charged, battery is faulty. 	Replace alternator or battery.

2-2-5. Glow plug is not heated (Engine starting performance is bad in cold weather)

Reference Fig. : 2-2-1

Check point	Check/Cause	Action
1. Glow Plug	<ul style="list-style-type: none"> • When starter switch is HEAT, measure voltage between glow plug inlet wire WG and chassis ground. Standard voltage : 12 V or more • If voltage is normal, glow plug is faulty. 	Replace glow plug.
2. Glow Relay	<p>(1) When starter switch is HEAT, measure voltage between glow relay terminal G inlet wire WB and chassis ground. Standard voltage : 12 V or more</p> <p>(2) When starter switch is HEAT, measure voltage between glow relay terminal g inlet wire Y and chassis ground. Standard voltage : 12 V or more</p> <p>(3) When starter switch is HEAT, measure voltage between glow relay terminal B outlet wire WG and chassis ground. Standard voltage : 12 V or more</p> <ul style="list-style-type: none"> • If above items (1) and (2) are OK and items (3) is NG, glow relay is faulty. 	Replace glow relay.
3. Harness Connecting Between Terminals	<ul style="list-style-type: none"> • Measure resistance of harness connecting between terminals. Standard resistance: 10 Ω or less • If resistance is abnormal, harness is faulty. 	Repair or replace harness.

2-2-6. Starter motor runs even when F-R lever is not at neutral

Reference Fig.: 2-2-1

Check point	Check/Cause	Action
1. F-R Lever Switch	<ul style="list-style-type: none"> • When starter switch is OFF and F-R lever is in forward or reverse, check continuity between F-R lever switch terminal COM and terminal NO. There is continuity in normal condition. • If there is no continuity, F-R lever switch is faulty. 	Replace F-R lever switch.

Fig.: 2-3-1

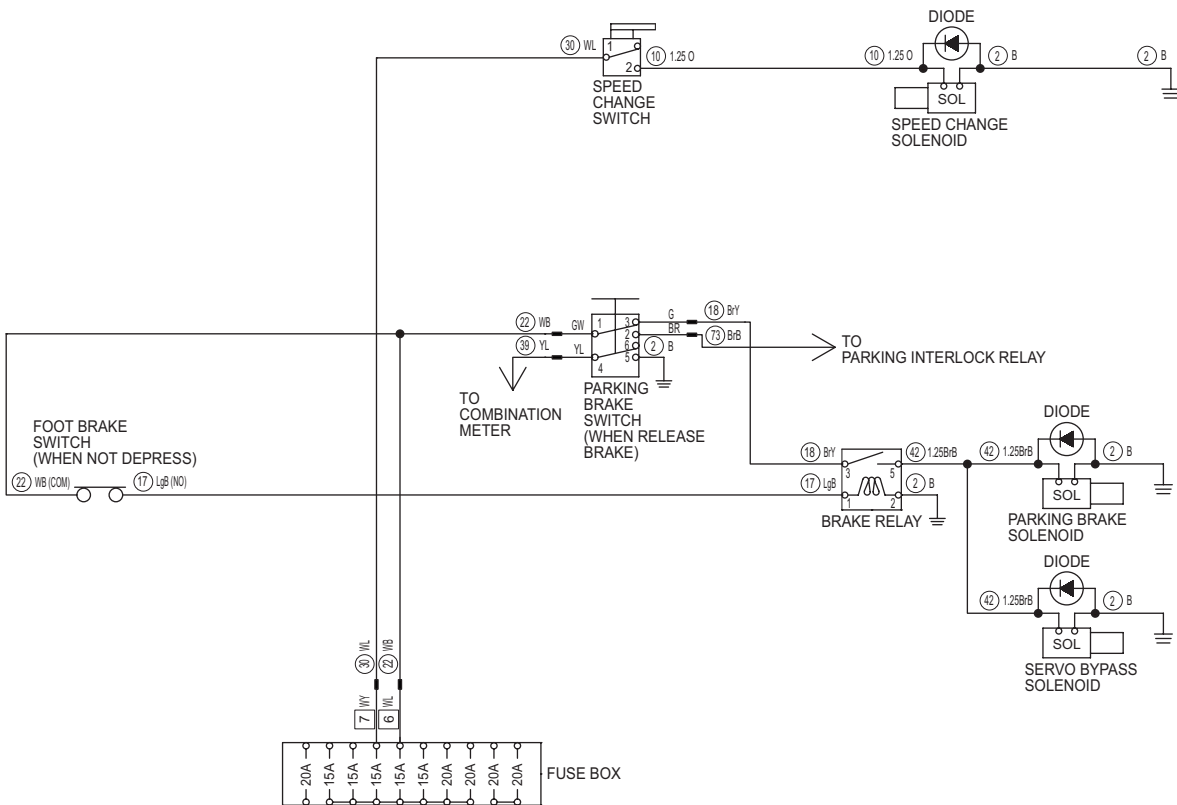

R2H-2-10002

2-3. Propulsion

Check following items before troubleshooting.

- No blown fuses and power is applied up to fuses.
- Check any ground circuit which belongs to components to be checked.

2-3-1. Machine moves neither forward nor backward

- Parking brake switch must be released.
- Foot brake switch must be ON (Brake pedal is not depressed).

Reference Fig.: 2-3-1

Check point	Check/Cause	Action
1. Servo Bypass Solenoid	<ul style="list-style-type: none"> • Disconnect harness and measure resistance of coil. Standard resistance : $9 \pm 0.9 \Omega$ • If resistance is abnormal, servo bypass solenoid is faulty. 	Replace servo bypass solenoid.
2. Parking Brake Solenoid	<ul style="list-style-type: none"> • Disconnect harness and measure resistance of coil. Standard resistance : $9 \pm 0.9 \Omega$ • If resistance is abnormal, parking brake solenoid is faulty. 	Replace parking brake solenoid.
3. Brake Relay	<p>(1) When starter switch is ON, measure voltage between brake relay terminal 3 inlet wire BrY and chassis ground. Standard voltage : 12 V or more</p> <p>(2) When starter switch is ON, measure voltage between brake relay terminal 1 inlet wire LgB and chassis ground. Standard voltage : 12 V or more</p> <p>(3) When starter switch is ON, measure voltage between brake relay terminal 5 outlet wire BrB and chassis ground. Standard voltage : 12 V or more</p> <ul style="list-style-type: none"> • If above items (1) and (2) are OK and item (3) is NG, brake relay is faulty. 	Replace brake relay.
4. Parking Brake Switch	<p>(1) When starter switch is ON, measure voltage between parking brake switch terminal 1 inlet wire WB and chassis ground. Standard voltage : 12 V or more</p> <p>(2) When starter switch is ON, measure voltage between parking brake switch terminal 3 outlet wire BrY and chassis ground. Standard voltage : 12 V or more</p> <ul style="list-style-type: none"> • If above item (1) is OK and item (2) is NG, parking brake switch is faulty. 	Replace parking brake switch.
5. Foot Brake Switch	<p>(1) When starter switch is ON, measure voltage between foot brake switch terminal COM inlet wire WB and chassis ground. Standard voltage : 12 V or more</p> <p>(2) When starter switch is ON, measure voltage between foot brake switch terminal NO outlet wire LgB and chassis ground. Standard voltage : 12 V or more</p> <ul style="list-style-type: none"> • If above item (1) is OK and item (2) is NG, foot brake switch is faulty. 	Replace foot brake switch.
6. Harness Connecting Between Terminals	<ul style="list-style-type: none"> • Measure resistance of harness connecting between terminals. Standard resistance : 10Ω or less • If resistance is abnormal, harness is faulty. 	Repair or replace harness.

Fig.: 2-3-1

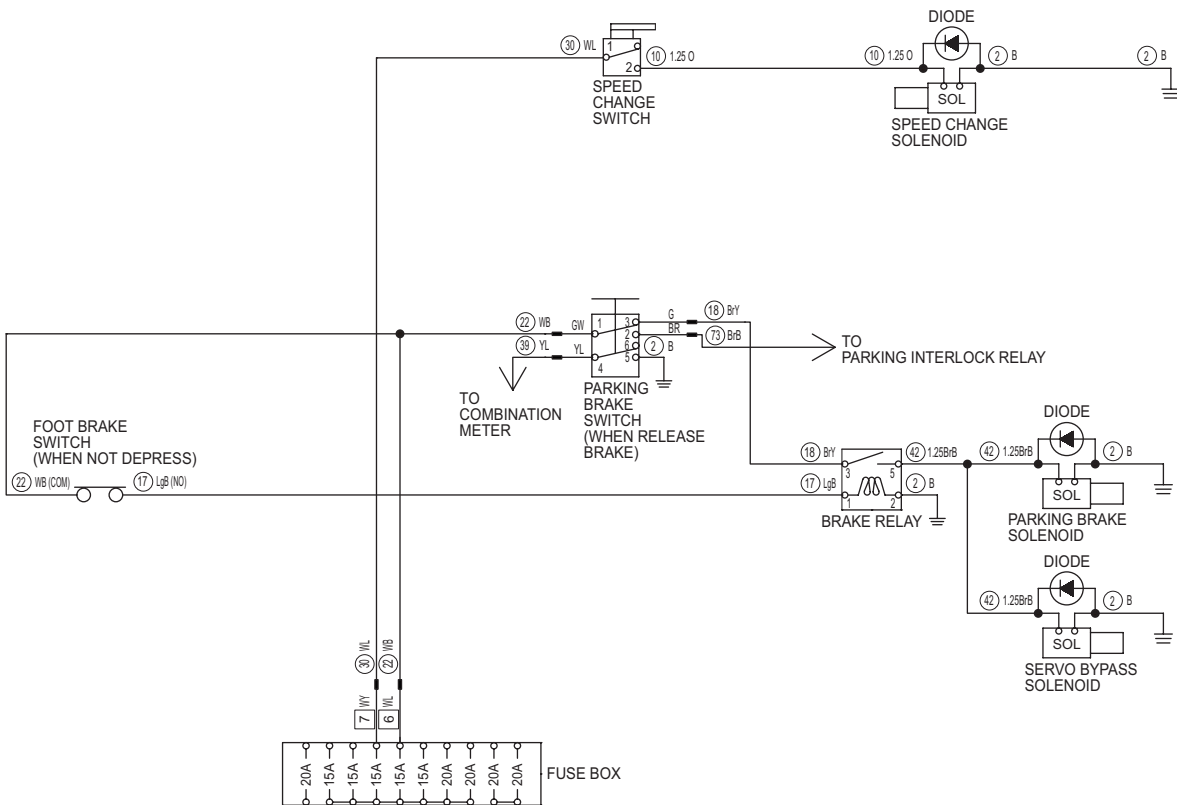

R2H-2-10002

2-3-2. Machine speed cannot be changed

- Speed change switch must be “”.

Reference Fig.: 2-3-1

Check point	Check/Cause	Action
1. Speed Change Solenoid	<ul style="list-style-type: none"> • Disconnect harness and measure resistance of coil. Standard voltage : $9 \pm 0.9 \Omega$ • If resistance is abnormal, speed change solenoid is faulty. 	Replace speed change solenoid.
2. Speed Change Switch	<p>(1) When starter switch is ON, measure voltage between speed change switch terminal 1 inlet wire WL and chassis ground. Standard voltage : 12 V or more</p> <p>(2) When starter switch is ON, measure voltage between speed change switch terminal 2 outlet wire O and chassis ground. Standard voltage : 12 V or more</p> <ul style="list-style-type: none"> • If above item (1) is OK and item (2) is NG, speed change switch is faulty. 	Replace speed change switch.
3. Harness Connecting Between Terminals	<ul style="list-style-type: none"> • Measure resistance of harness connecting between terminals. Standard resistance : 10Ω or less • If resistance is abnormal, harness is faulty. 	Repair or replace harness.

Fig.: 2-3-1

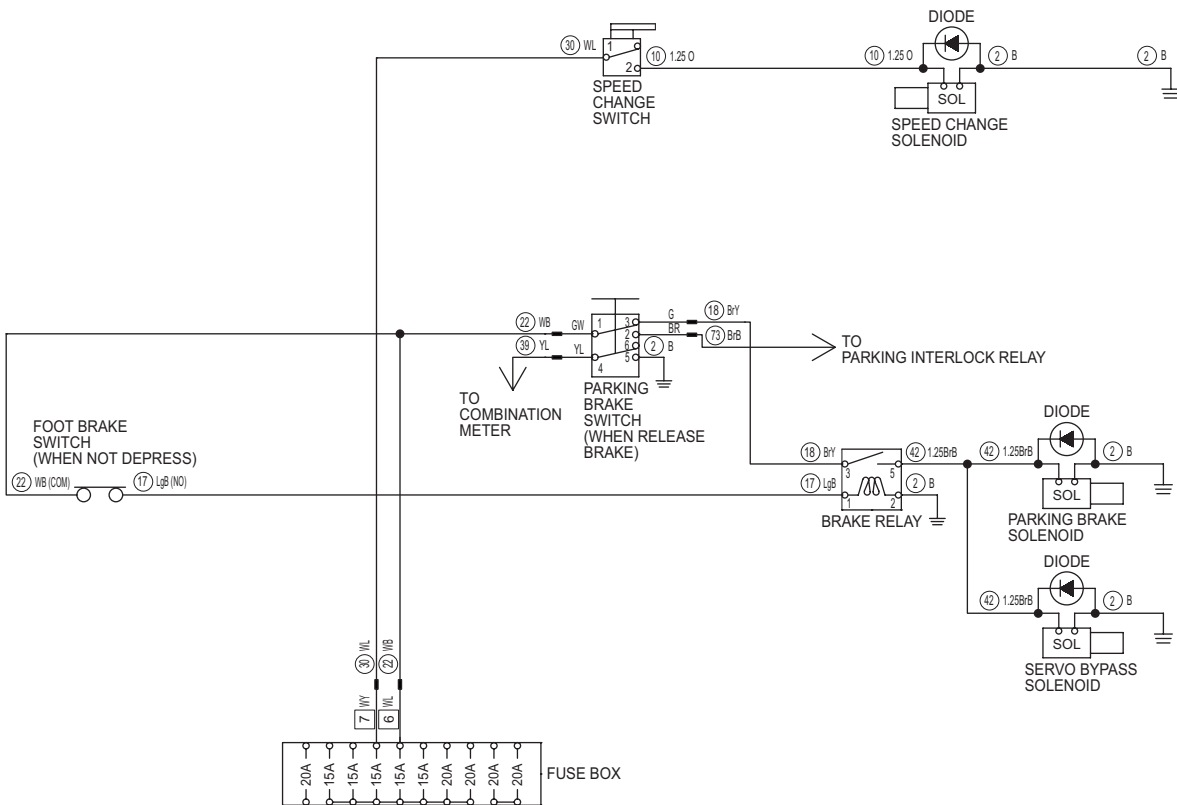

R2H-2-10002

2-3-3. Brake cannot be released

- Parking brake switch must be released.
- Foot brake switch must be ON (Brake pedal is not depressed).

Reference Fig.: 2-3-1

Check point	Check/Cause	Action
1. Parking Brake Solenoid	<ul style="list-style-type: none"> • Disconnect harness and measure resistance of coil. Standard voltage : $9 \pm 0.9 \Omega$ • If measured resistance is abnormal, brake solenoid is faulty. 	Replace parking brake solenoid.
2. Brake Relay	<p>(1) When starter switch is ON, measure voltage between brake relay terminal 3 inlet wire BrY and chassis ground. Standard voltage : 12 V or more</p> <p>(2) When starter switch is ON, measure voltage between brake relay terminal 1 inlet wire LgB and chassis ground. Standard voltage : 12 V or more</p> <p>(3) When starter switch is ON, measure voltage between brake relay terminal 5 outlet wire BrB and chassis ground. Standard voltage : 12 V or more</p> <ul style="list-style-type: none"> • If above items (1) and (2) are OK and item (3) is NG, brake relay is faulty. 	Replace brake relay.
3. Parking Brake Switch	<p>(1) When starter switch is ON, measure voltage between parking brake switch terminal 1 inlet wire WB and chassis ground. Standard voltage : 12 V or more</p> <p>(2) When starter switch is ON, measure voltage between parking brake switch terminal 3 outlet wire BrY and chassis ground. Standard voltage : 12 V or more</p> <ul style="list-style-type: none"> • If above item (1) is OK and item (2) is NG, parking brake switch is faulty. 	Replace parking brake switch.
4. Foot Brake Switch	<p>(1) When starter switch is ON, measure voltage between foot brake switch terminal COM inlet wire WB and chassis ground. Standard voltage : 12 V or more</p> <p>(2) When starter switch is ON, measure voltage between foot brake switch terminal NO outlet wire LgB and chassis ground. Standard voltage : 12 V or more</p> <p>If above item (1) is OK and item (2) is NG, foot brake switch is faulty.</p>	Replace foot brake switch.
5. Harness Connecting Between Terminals	<ul style="list-style-type: none"> • Measure resistance of harness connecting between terminals. Standard resistance : 10 Ω or less • If resistance is abnormal, harness is faulty. 	Repair or replace harness.

Fig.: 2-3-1

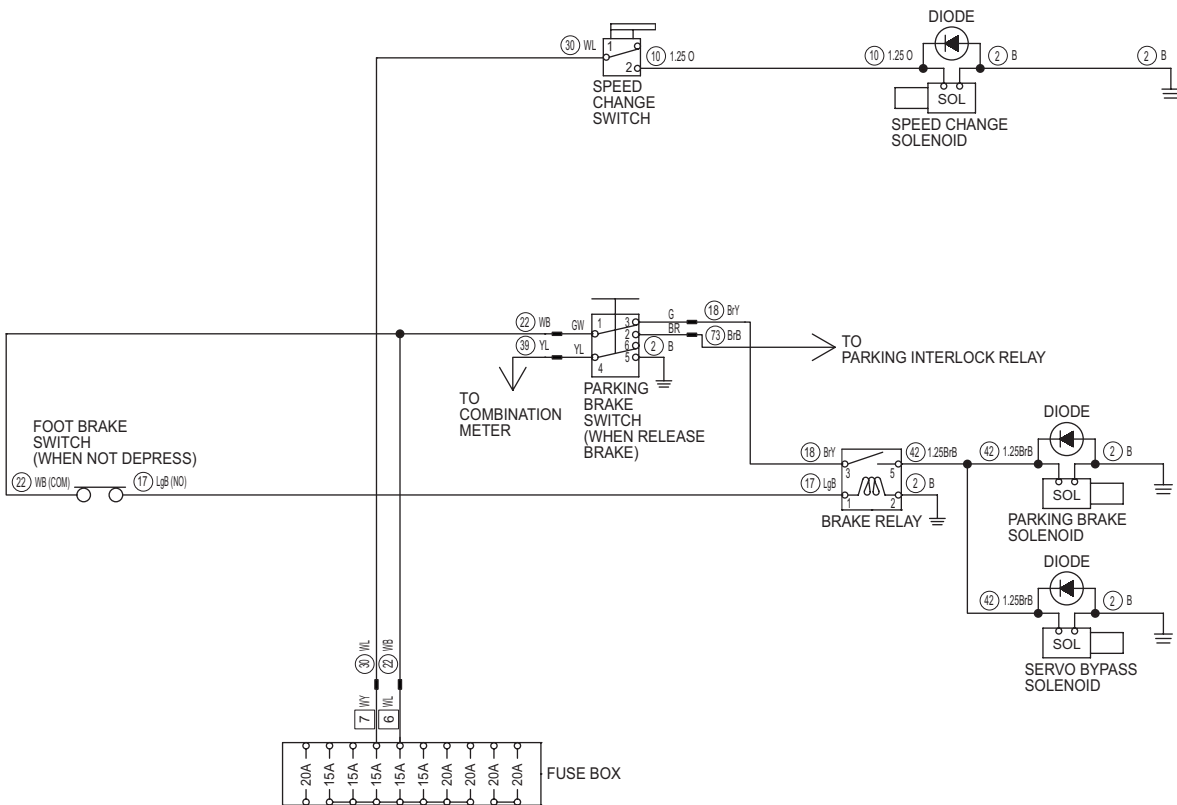

R2H-2-10002

2-3-4. Brake does not work

- Parking brake switch must be applied.
- Foot brake switch must be OFF (Brake pedal is depressed).

Reference Fig.: 2-3-1

Check point	Check/Cause	Action
1. Parking Brake Solenoid	<ul style="list-style-type: none"> • Disconnect harness and measure resistance of coil. Standard resistance : $9 \pm 0.9 \Omega$ • If measured resistance is abnormal, parking brake solenoid is faulty. 	Replace parking brake solenoid.
2. Brake Relay	<p>(1) When starter switch is ON, measure voltage between brake relay terminal 1 inlet wire LgB and chassis ground. There is no electricity in normal condition.</p> <p>(2) When starter switch is ON, measure voltage between brake relay terminal 5 outlet wire BrB and chassis ground. There is no electricity in normal condition.</p> <ul style="list-style-type: none"> • If above item (1) is OK and item (2) is NG, brake relay is faulty. 	Replace brake relay.
3. Parking Brake Switch	<p>(1) When starter switch is ON, measure voltage between parking brake switch terminal 1 inlet wire GW and chassis ground. Standard voltage : 12 V or more</p> <p>(2) When starter switch is ON, measure voltage between parking brake switch terminal 3 outlet wire G and chassis ground. There is no electricity in normal condition.</p> <ul style="list-style-type: none"> • If above item (1) is OK and item (2) is NG, parking brake switch is faulty. 	Replace parking brake switch.
4. Foot Brake Switch	<ul style="list-style-type: none"> • When starter switch is ON, measure voltage between foot brake switch terminal NO outlet wire LgB and chassis ground. There is no electricity in normal condition. • If electricity flows, foot brake switch is faulty. 	Replace foot brake switch.
5. Harness Connecting Between Terminals	<ul style="list-style-type: none"> • Measure resistance of harness connecting between terminals. Standard resistance : 10Ω or less • If resistance is abnormal, harness is faulty. 	Repair or replace harness.

Fig. : 2-4-1

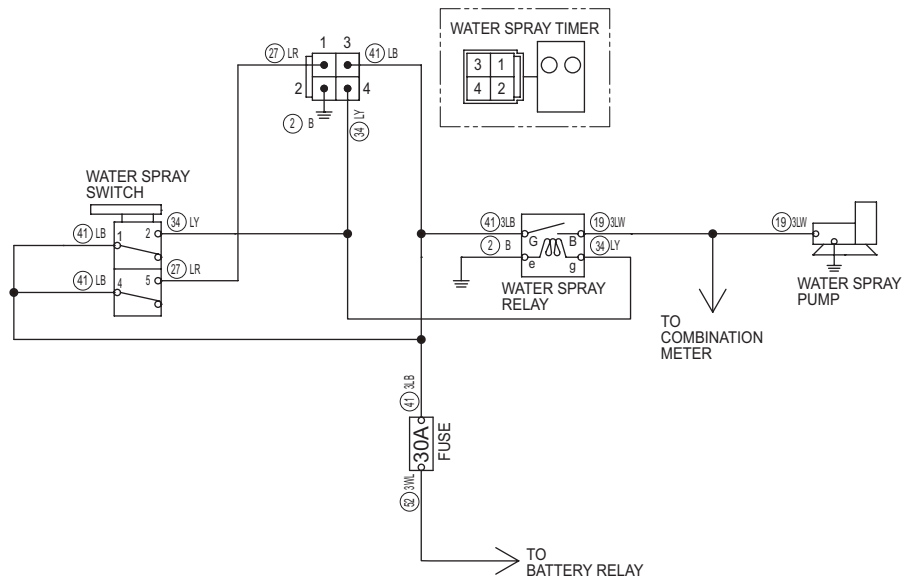

R2H-2-10004

2-4. Water Sprays

Check following items before troubleshooting.

- No blown fuses.
- Check any ground circuit which belongs to components to be checked.

2-4-1. Continuous water spray does not operate

- Water spray switch must be "ON" (continuous spraying).

Reference Fig. : 2-4-1

Check point	Check/Cause	Action
1. Water Spray Pump	(1) When starter switch is ON, measure voltage between water spray pump terminal inlet wire LW and chassis ground. Standard voltage: 12 V or more (2) Check that no abnormality is found in water spray pump ground terminal. • If above items (1) and (2) are OK and water spray pump does not operate, water spray pump is faulty.	Replace water spray pump.
2. Water Spray Relay	(1) When starter switch is ON, measure voltage between water spray relay terminal g inlet wire LY and chassis ground. Standard voltage: 12 V or more (2) When starter switch is ON, measure voltage between water spray relay terminal G inlet wire LB and chassis ground. Standard voltage: 12 V or more (3) When starter switch is ON, measure voltage between water spray relay terminal B outlet wire LW and chassis ground. Standard voltage: 12 V or more • If above items (1) and (2) are OK and item (3) is NG, water spray relay is faulty.	Replace water spray relay.
3. Water Spray Switch	(1) When starter switch is ON, measure voltage between water spray switch terminal 1 inlet wire LB and chassis ground. Standard voltage: 12 V or more (2) When starter switch is ON, measure voltage between water spray switch terminal 2 outlet wire LY and chassis ground. Standard voltage: 12 V or more • If above item (1) is OK and item (2) is NG, water spray switch is faulty.	Replace water spray switch.
4. Harness Connecting Between Terminals	• Measure resistance of harness connecting between terminals. Standard resistance: 10 Ω or less • If resistance is abnormal, harness is faulty.	Repair or replace harness.

Fig. : 2-4-1

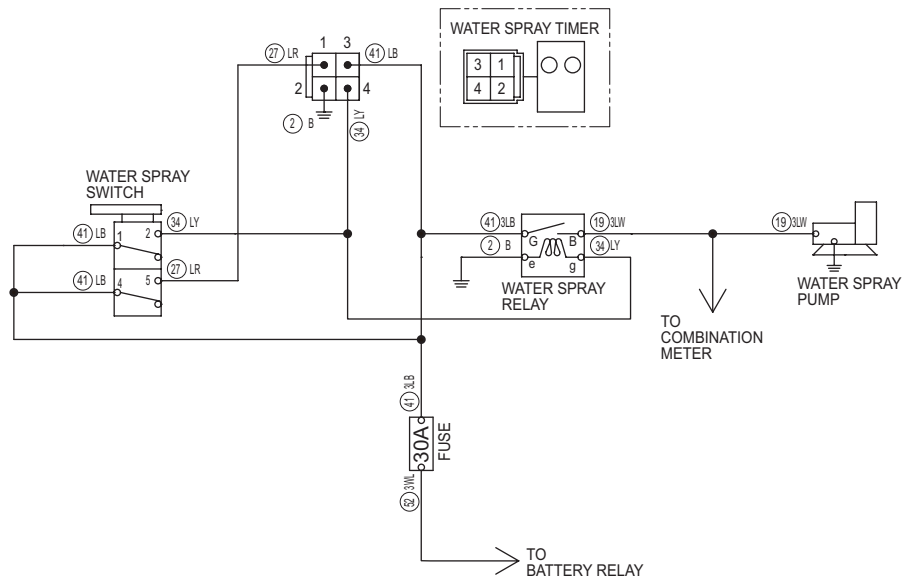

R2H-2-10004

2-4-2. Continuous water spray works, but intermittent water spray does not operate

- Water spray switch must be “INT” (intermittent water spraying).

Reference Fig. : 2-4-1

Check point	Check/Cause	Action
1. Water Spray Timer	<p>(1) When starter switch is ON, measure voltage between water spray timer terminal 1 inlet wire LR, terminal 3 inlet wire LB and chassis ground. Standard voltage: 12 V or more</p> <p>(2) When starter switch is ON, measure voltage between water spray timer terminal 4 outlet wire LY and chassis ground. Standard voltage: 12 V or more (Electricity flows for a definite time.)</p> <ul style="list-style-type: none"> • If above item (1) is OK and item (2) is NG, water spray timer is faulty. 	Replace water spray timer.
2. Water Spray Switch	<p>(1) When starter switch is ON, measure voltage between water spray switch terminal 4 inlet wire LB and chassis ground. Standard voltage: 12 V or more</p> <p>(2) When starter switch is ON, measure voltage between water spray switch terminal 5 outlet wire LR and chassis ground. Standard voltage: 12 V or more</p> <ul style="list-style-type: none"> • If above item (1) is OK and item (2) is NG, water spray switch is faulty. 	Replace water spray switch.
3. Harness Connecting Between Terminals	<ul style="list-style-type: none"> • Measure resistance of harness connecting between terminals. Standard resistance: 10 Ω or less • If resistance is abnormal, harness is faulty. 	Repair or replace harness.

Fig.: 2-5-1

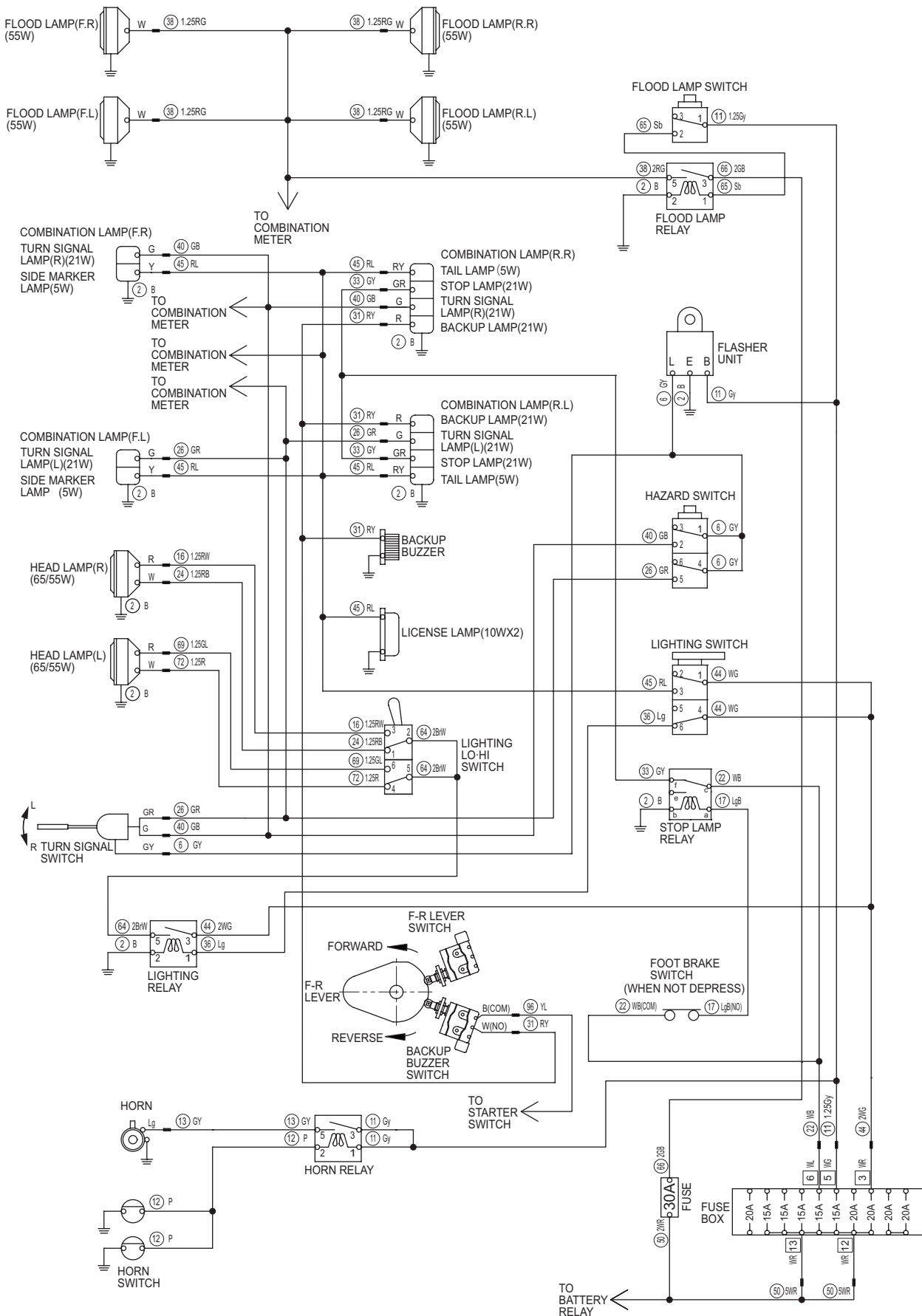





2-5. Lighting

Check following item before troubleshooting.

- No blown fuses and power is applied up to fuses.
- When measuring voltage and current without disconnecting connectors, refer to “measuring voltage and current following using tester” (P.10-006 to P.10-008).
- Check any ground circuit which belongs to components to be checked.



2-5-1. Head lamp, side marker lamp, tail lamp and license lamp do not light 1/2

Reference Fig.: 2-5-1

Check point	Check/Cause	Action
1. Each Bulb	<ul style="list-style-type: none"> • Check that none of lamp bulbs is burned out or has a contact failure. • Bulb is faulty or poorly connected. 	Replace each bulb.
2. Lighting Switch	<p>(1) When starter switch is ON, measure voltage between lighting switch terminal 1 inlet wire WG, terminal 4 inlet wire WG and chassis ground. Standard voltage: 12 V or more</p> <p>(2) When starter switch is ON and lighting switch is “”, measure voltage between lighting switch terminal 3 outlet wire RL and chassis ground. Standard voltage: 12 V or more</p> <p>(3) When starter switch is ON and lighting switch is “”, measure voltage between lighting switch terminal 5 outlet wire Lg and chassis ground. Standard voltage: 12 V or more</p> <ul style="list-style-type: none"> • If above item (1) is OK and item (2) or (3) is NG, lighting switch is faulty. 	Replace lighting switch.
3. Lighting Relay	<p>(1) When starter switch is ON, measure voltage between lighting relay terminal 3 inlet wire WG and chassis ground. Standard voltage: 12 V or more</p> <p>(2) When starter switch is ON and lighting switch is “”, measure voltage between lighting relay terminal 1 inlet wire Lg and chassis ground. Standard voltage: 12 V or more</p> <p>(3) When starter switch is ON and lighting switch is “”, measure voltage between lighting relay terminal 5 outlet wire BrW and chassis ground. Standard voltage: 12 V or more</p> <ul style="list-style-type: none"> • If above items (1) and (2) are OK and item (3) is NG, lighting relay is faulty. 	Replace lighting relay.

2-5-1. Head lamp, side marker lamp, tail lamp and license lamp do not light 2/2

Reference Fig.: 2-5-1

Check point	Check/Cause	Action
4. Lighting Lo-Hi Switch	<p>(1) When starter switch is ON and lighting switch is “”, measure voltage between lighting Lo-Hi switch terminal 2 inlet wire BrW, terminal 5 inlet wire BrW and chassis ground. Standard voltage: 12 V or more</p> <p>(2) When starter switch is ON, lighting switch is “” and lighting Lo-Hi switch is “”, measure voltage between lighting Lo-Hi switch terminal wires and chassis ground. Head lamp (R): Terminal 1 outlet wire RB Head lamp (L) : Terminal 4 outlet wire R Standard voltage: 12 V or more</p> <ul style="list-style-type: none"> • If above (1) is OK and (2) is NG, lighting Lo-Hi switch is faulty. 	Replace lighting Lo-Hi switch.
5. Harness Connecting Between Terminals	<p>Measure resistance of harness connecting between terminals. Standard resistance: 10 Ω or less</p> <ul style="list-style-type: none"> • If resistance is abnormal, harness is faulty. 	Repair or replace harness.

2-5-2. Flood lamp does not light 1/2

Reference Fig.: 2-5-1

Check point	Check/Cause	Action
1. Each Bulb	<ul style="list-style-type: none"> • Check that none of lamp bulbs is burned out or has a contact failure. • Bulb is faulty or poorly connected. 	Replace each bulb.
2. Flood Lamp Switch	<p>(1) When starter switch is ON, measure voltage between flood lamp switch terminal 1 inlet wire Gy and chassis ground. Standard voltage: 12 V or more</p> <p>(2) When starter switch is ON and flood lamp switch is ON, measure voltage between flood lamp switch terminal 2 outlet wire Sb and chassis ground. Standard voltage: 12 V or more</p> <ul style="list-style-type: none"> • If above (1) is OK and (2) is NG, flood lamp switch is faulty. 	Replace flood lamp switch.
3. Flood Lamp Relay	<p>(1) When starter switch is ON, measure voltage between flood lamp relay terminal 3 inlet wire GB and chassis ground. Standard voltage: 12 V or more</p> <p>(2) When starter switch is ON and flood lamp switch is ON, measure voltage between flood lamp relay terminal 1 inlet wire Sb and chassis ground. Standard voltage: 12 V or more</p> <p>(3) When starter switch is ON and flood lamp switch is ON, measure voltage between flood lamp relay terminal 5 outlet wire RG and chassis ground. Standard voltage: 12 V or more</p> <ul style="list-style-type: none"> • If above items (1) and (2) are OK and item (3) is NG, flood lamp relay is faulty. 	Replace flood lamp relay.



2-5-2. Flood lamp does not light 2/2

Reference Fig.: 2-5-1

Check point	Check/Cause	Action
4. Harness Connecting Between Terminals	Measure resistance of harness connecting between terminals. Standard resistance: 10 Ω or less • If resistance is abnormal, harness is faulty.	Repair or replace harness.

2-5-3. High-beam of head lamp does not light

Reference Fig.: 2-5-1

Check point	Check/Cause	Action
1. Each Bulb	<ul style="list-style-type: none"> • Check that none of lamp bulbs is burned out or has a contact failure. • Bulb is faulty or poorly connected. 	Replace each bulb.
2. Lighting Lo-Hi Switch	(1) When starter switch is ON and lighting switch is “  ”, measure voltage between lighting Lo-Hi switch terminal 2 inlet wire BrW, terminal 5 inlet wire BrW and chassis ground. Standard voltage: 12 V or more (2) When starter switch is ON, lighting switch is “  ” and lighting Lo-Hi switch is “  ”, measure voltage between lighting Lo-Hi switch terminal wires and chassis ground. Head lamp (R): Terminal 3 outlet wire RW Head lamp (L) : Terminal 6 outlet wire GL Standard voltage: 12 V or more • If above (1) is OK and (2) is NG, lighting Lo-Hi switch is faulty.	Replace lighting Lo-Hi switch.
3. Harness Connecting Between Terminals	Measure resistance of harness connecting between terminals. Standard resistance: 10 Ω or less • If resistance is abnormal, harness is faulty.	Repair or replace harness.

2-5-4. Turn signal light does not blink

Reference Fig.: 2-5-1

Check point	Check/Cause	Action
1. Each Bulb	<ul style="list-style-type: none"> • Check that none of lamp bulbs is burned out or has a contact failure. • Bulb is faulty or poorly connected. 	Replace each bulb.
2. Flasher Unit	<p>(1) When starter switch is ON, measure voltage between flasher unit terminal B inlet wire Gy and chassis ground. Standard voltage: 12 V or more</p> <p>(2) When starter switch is ON and turn signal lever is moved, measure voltage between flasher unit terminal L outlet wire GY and chassis ground. Standard voltage: 12 V or more with constant intervals</p> <ul style="list-style-type: none"> • If above (1) is OK and (2) is NG, flasher unit is faulty. 	Replace flasher unit.
3. Turn Signal Switch	<p>(1) When starter switch is ON and turn signal lever is moved, measure voltage between turn signal switch terminal inlet wire GY and chassis ground. Standard voltage: 12 V or more with constant intervals</p> <p>(2) When starter switch is ON and turn signal lever is moved, measure voltage between turn signal switch terminal wires and chassis ground. Front and rear turn signal lamp (R): Outlet wire GB Front and rear turn signal lamp (L): Outlet wire GR Standard voltage: 12 V or more with constant intervals</p> <ul style="list-style-type: none"> • If above (1) is OK and (2) is NG, turn signal switch is faulty. 	Replace turn signal switch.
4. Harness Connecting Between Terminals	<p>Measure resistance of harness connecting between terminals. Standard resistance: 10 Ω or less</p> <ul style="list-style-type: none"> • If resistance is abnormal, harness is faulty. 	Repair or replace harness.

Fig.: 2-5-1

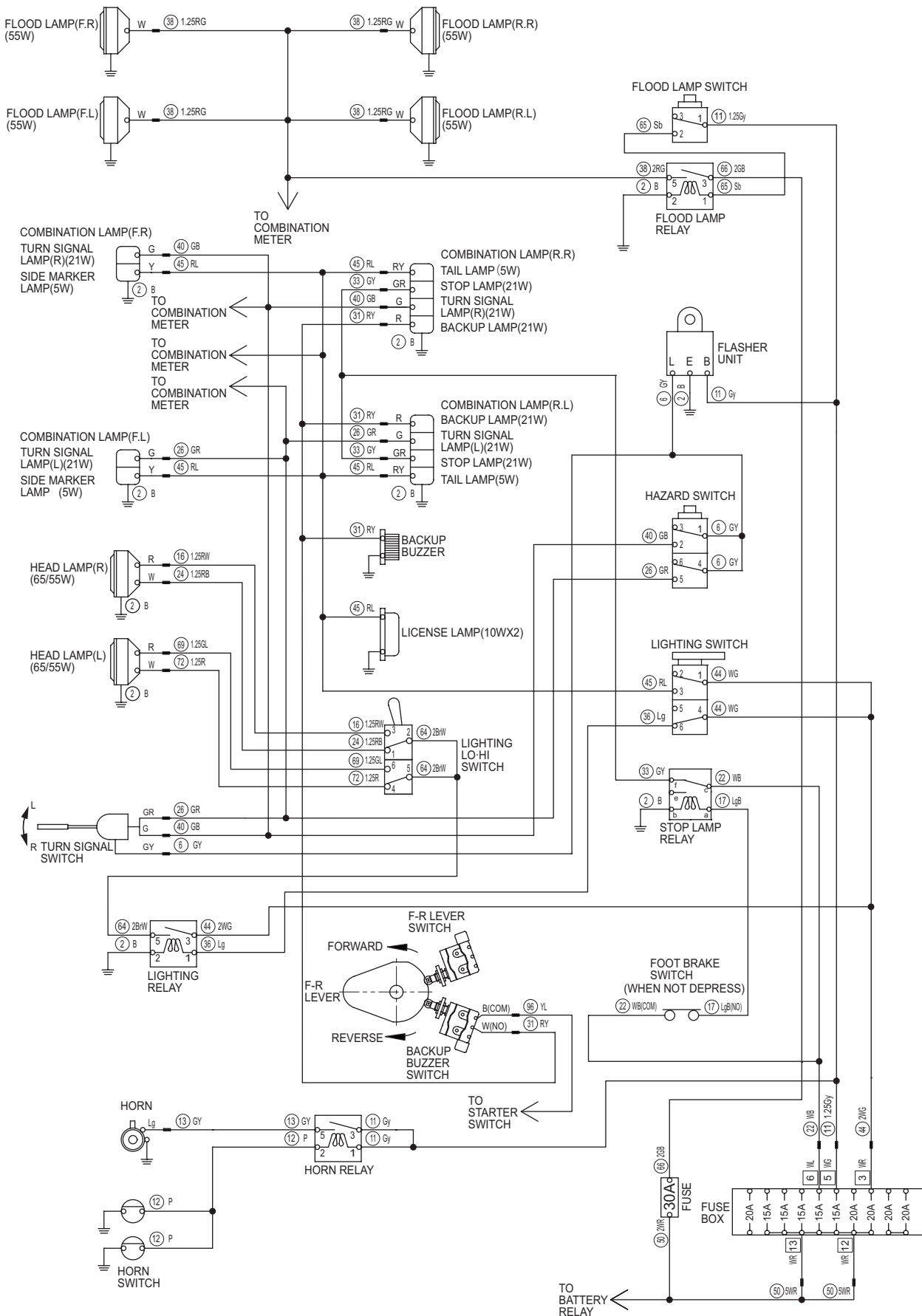

R2H-2-10005

2-5-5. Hazard lamp does not light (Turn signal blinks)

Reference Fig.: 2-5-1

Check point	Check/Cause	Action
1. Each Bulb	<ul style="list-style-type: none"> • Check that none of lamp bulbs is burned out or has a contact failure. • Bulb is faulty or poorly connected. 	Replace each bulb.
2. Hazard Switch	<p>(1) When starter switch is ON and hazard switch is ON, measure voltage between hazard switch terminal 1 inlet wire GY, terminal 4 inlet wire GY and chassis ground. Standard voltage: 12 V or more with constant intervals</p> <p>(2) When starter switch is ON and hazard switch is ON, measure voltage between hazard switch terminal 2 outlet wire GB and chassis ground. Standard voltage: 12 V or more with constant intervals</p> <p>(3) When starter switch is ON and hazard switch is ON, measure voltage between hazard switch terminal 5 outlet wire GR and chassis ground. Standard voltage: 12 V or more with constant intervals</p> <ul style="list-style-type: none"> • If above (1) is OK and above (2) and (3) are NG, hazard switch is faulty. 	Replace hazard switch.
3. Harness Connecting Between Terminals	<p>Measure resistance of harness connecting between terminals. Standard resistance: 10 Ω or less</p> <ul style="list-style-type: none"> • If resistance is abnormal, harness is faulty. 	Repair or replace harness.

2-5-6. Backup lamp does not light

Reference Fig.: 2-5-1

Check point	Check/Cause	Action
1. Each Bulb	<ul style="list-style-type: none"> • Check that none of lamp bulbs is burned out or has a contact failure. • Bulb is faulty or poorly connected. 	Replace each bulb.
2. Backup buzzer Switch	<p>(1) When starter switch is ON, measure voltage between backup buzzer switch COM terminal inlet wire YL and chassis ground. Standard voltage: 12 V or more</p> <p>(2) When starter switch is ON and F-R lever is in reverse, measure voltage between backup buzzer switch NO terminal outlet wire RY and chassis ground. Standard voltage: 12 V or more</p> <ul style="list-style-type: none"> • If above (1) is OK and (2) is NG, backup buzzer switch is faulty. 	Replace backup buzzer switch.
3. Harness Connecting Between Terminals	<p>Measure resistance of harness connecting between terminals. Standard resistance: 10 Ω or less</p> <ul style="list-style-type: none"> • If resistance is abnormal, harness is faulty. 	Repair or replace harness.

2-5-7. Stop lamp does not light

Reference Fig.: 2-5-1

Check point	Check/Cause	Action
1. Each Bulb	<ul style="list-style-type: none"> • Check that none of lamp bulbs is burned out or has a contact failure. • Bulb is faulty or poorly connected. 	Replace each bulb.
2. Foot Brake Switch	<p>(1) When starter switch is ON, measure voltage between foot brake switch terminal inlet wire WB and chassis ground. Standard voltage: 12 V or more</p> <p>(2) When starter switch is ON while foot brake is depressed, measure voltage between foot brake switch terminal outlet wire LgB and chassis ground. There is no electricity in normal condition.</p> <ul style="list-style-type: none"> • If above (1) is OK and (2) is NG, foot brake switch is faulty. 	Replace foot brake switch.
3. Stop Lamp Relay	<p>(1) When starter switch is ON, measure voltage between stop lamp relay terminal c inlet wire WB and chassis ground. Standard voltage: 12 V or more</p> <p>(2) When starter switch is ON, measure voltage between stop lamp relay terminal f outlet wire GY and chassis ground. There is no electricity in normal condition.</p> <p>(3) When starter switch is ON while foot brake is depressed, measure voltage between stop lamp relay terminal f outlet wire GY and chassis ground. Standard voltage: 12 V or more</p> <ul style="list-style-type: none"> • If above item (1) and (2) are OK and item (3) is NG, stop lamp relay is faulty. 	Replace stop lamp relay.
4. Harness Connecting Between Terminals	<p>Measure resistance of harness connecting between terminals. Standard resistance: 10 Ω or less</p> <ul style="list-style-type: none"> • If resistance is abnormal, harness is faulty. 	Repair or replace harness.

Fig.: 2-5-2

COMBI.METER SET

38 PULS/REV SET			
REV RATIO SEL.			
1	2	3	4
OPEN	OPEN	GND	OPEN

TEMP. 50-103 °C SET	
TEMP.CURVE SEL.	
1	2
OPEN	OPEN

COMBINATION METER

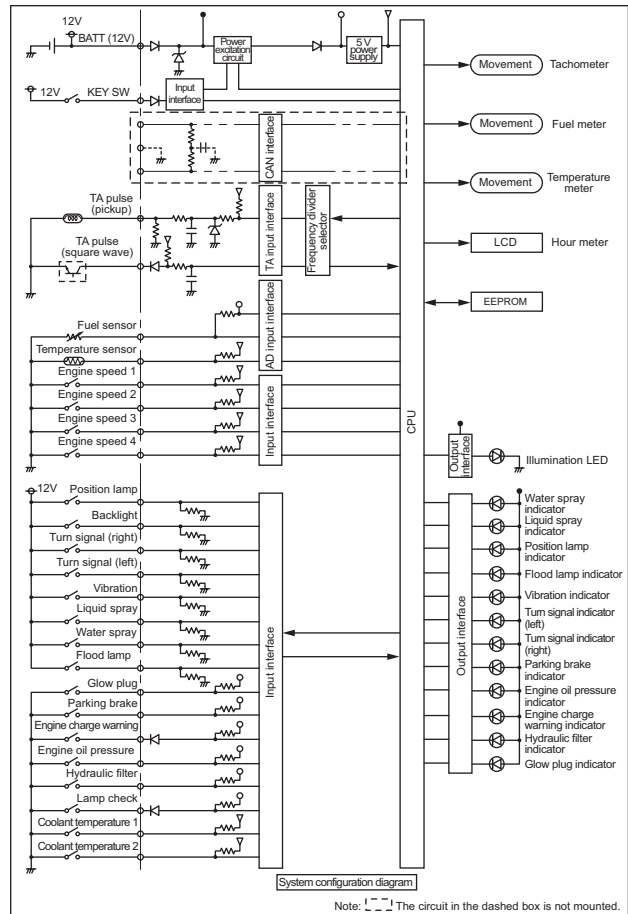
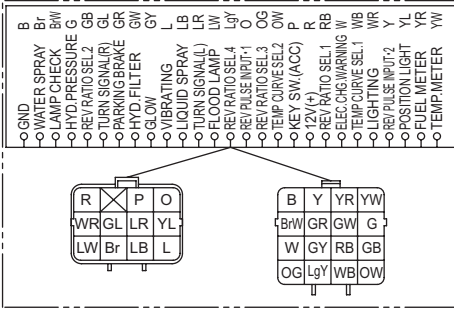

Note: L... The circuit in the dashed box is not mounted.

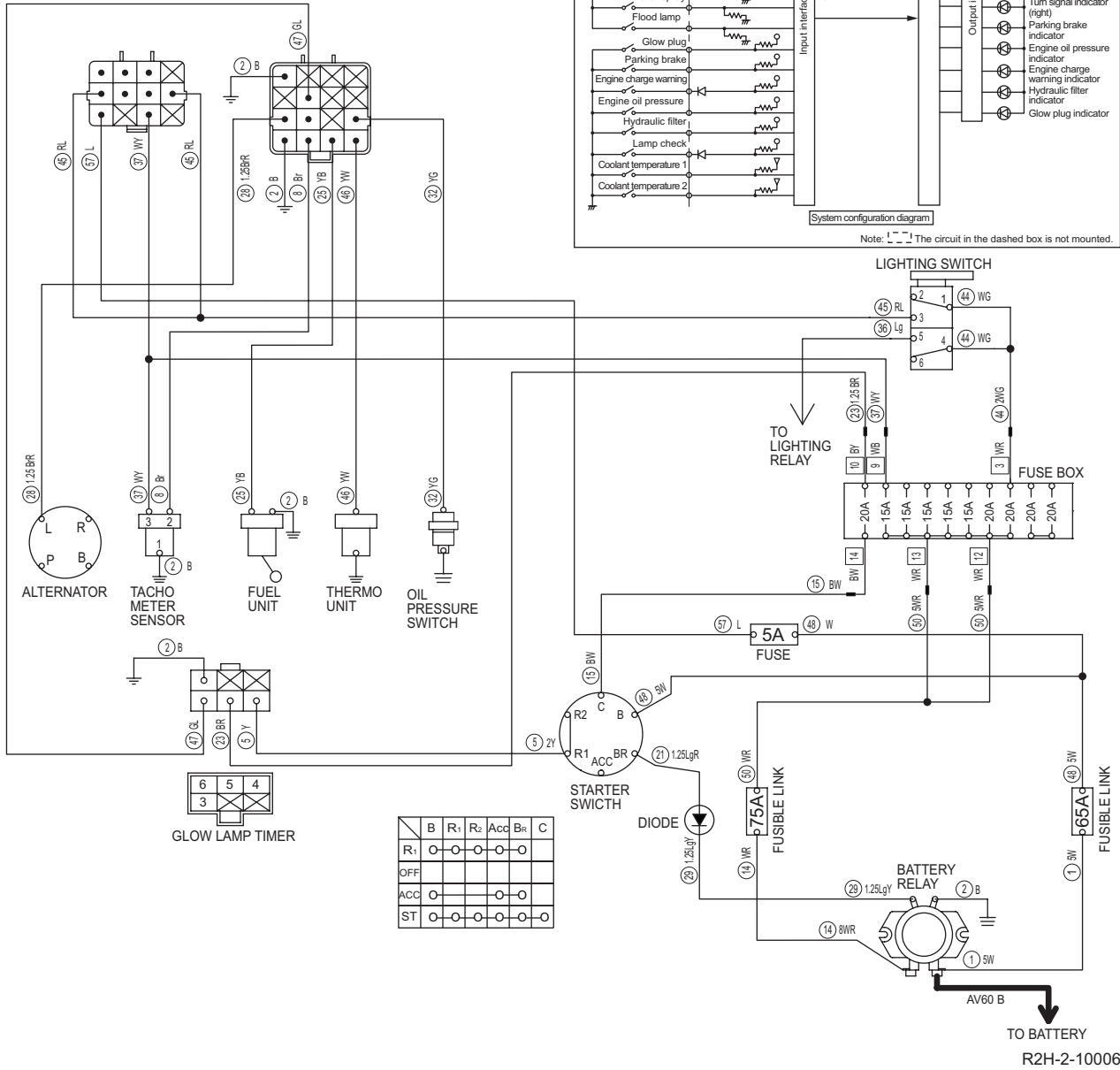

	B	R ₁	R ₂	Acc	Br	C
R ₁	O	O	O	O	O	O
OFF						
ACC	O			O	O	O
ST	O	O	O	O	O	O

2-5-8. Illumination of combination meter does not turn on

Reference Fig. : 2-5-2

Check point	Check/Cause	Action
1. Harness	<ul style="list-style-type: none"> • Measure resistance between lighting switch terminal 3 wire RL and combination meter connector terminal wire No. 45 wire RL. Standard resistance : 10 Ω or less • If resistance is abnormal, harness is faulty. 	Repair or replace harness.
2. Combination Meter (Back lighting)	<p>(1) When starter switch is ON, measure voltage between combination meter terminal wires and ground terminal wire.</p> <ul style="list-style-type: none"> • Battery terminal wire No. 57 inlet wire L and ground terminal wire No. 2 wire B • Starter switch terminal wire No. 37 inlet wire WY and ground terminal wire No. 2 wire B <p>Standard voltage : 12 V or more</p> <p>(2) When starter switch is ON and lighting switch is “”, measure voltage between combination meter back lighting terminal wire No. 45 inlet wire RL and chassis ground.</p> <p>Standard voltage : 12 V or more</p> <ul style="list-style-type: none"> • If above items (1) and (2) are OK and combination meter does not turn on, combination meter is faulty. 	Replace combination meter.

2-5-9. Combination meter warning lamp or indicator lamp is abnormal

Reference Fig. : 2-5-2

Check point	Check/Cause	Action
1. Combination Meter (Lamp check)	<p>(1) When starter switch is ON, measure voltage between combination meter terminal wires and ground terminal wire.</p> <ul style="list-style-type: none"> • Battery terminal wire No. 57 inlet wire L and ground terminal wire No. 2 wire B • Starter switch terminal wire No. 37 inlet wire WY and ground terminal wire No. 2 wire B <p>Standard voltage: 12 V or more</p> <p>(2) When starter switch is ON, check that parking brake indicator lamp, oil pressure warning lamp and charge warning lamp illuminate and then go out after starting engine.</p> <ul style="list-style-type: none"> • If above item (1) is OK and item (2) is NG, combination meter is faulty. <p>(NOTICE)</p> <ul style="list-style-type: none"> • Since engine cannot start unless parking brake switch is applied, parking brake indicator lamp does not go out even after starting engine. 	Replace combination meter.

Fig.: 2-5-2

COMBI.METER SET

38 PULS/REV SET			
REV RATIO SEL.			
1	2	3	4
OPEN	OPEN	GND	OPEN

TEMP. 50-103 °C SET	
TEMP.CURVE SEL.	
1	2
OPEN	OPEN

COMBINATION METER

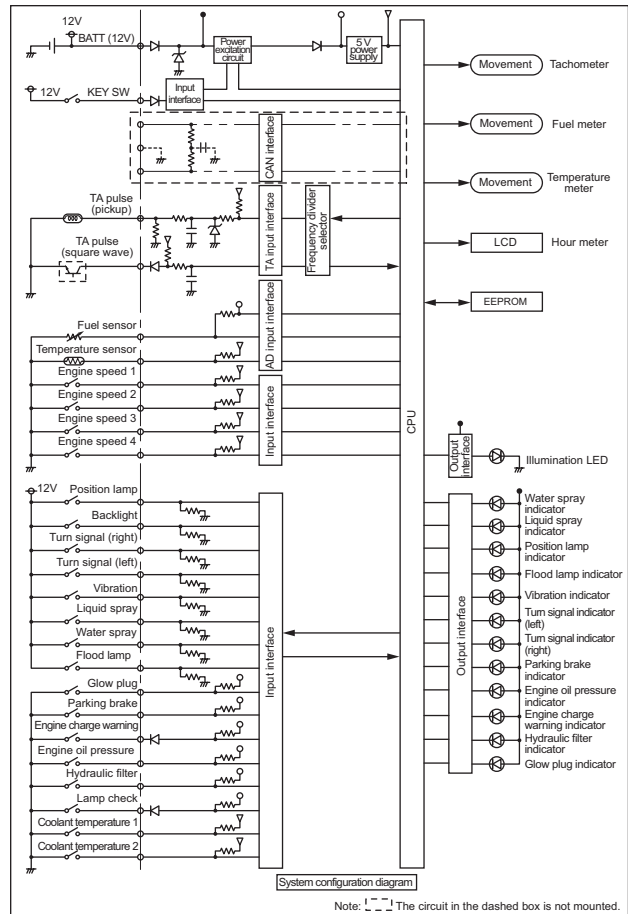
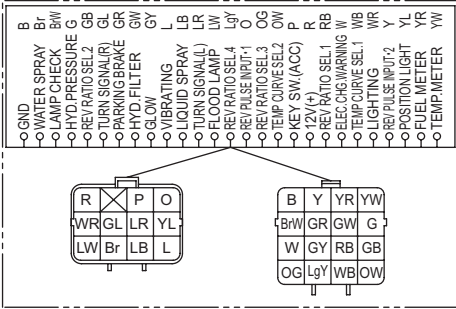

Note: L... The circuit in the dashed box is not mounted.

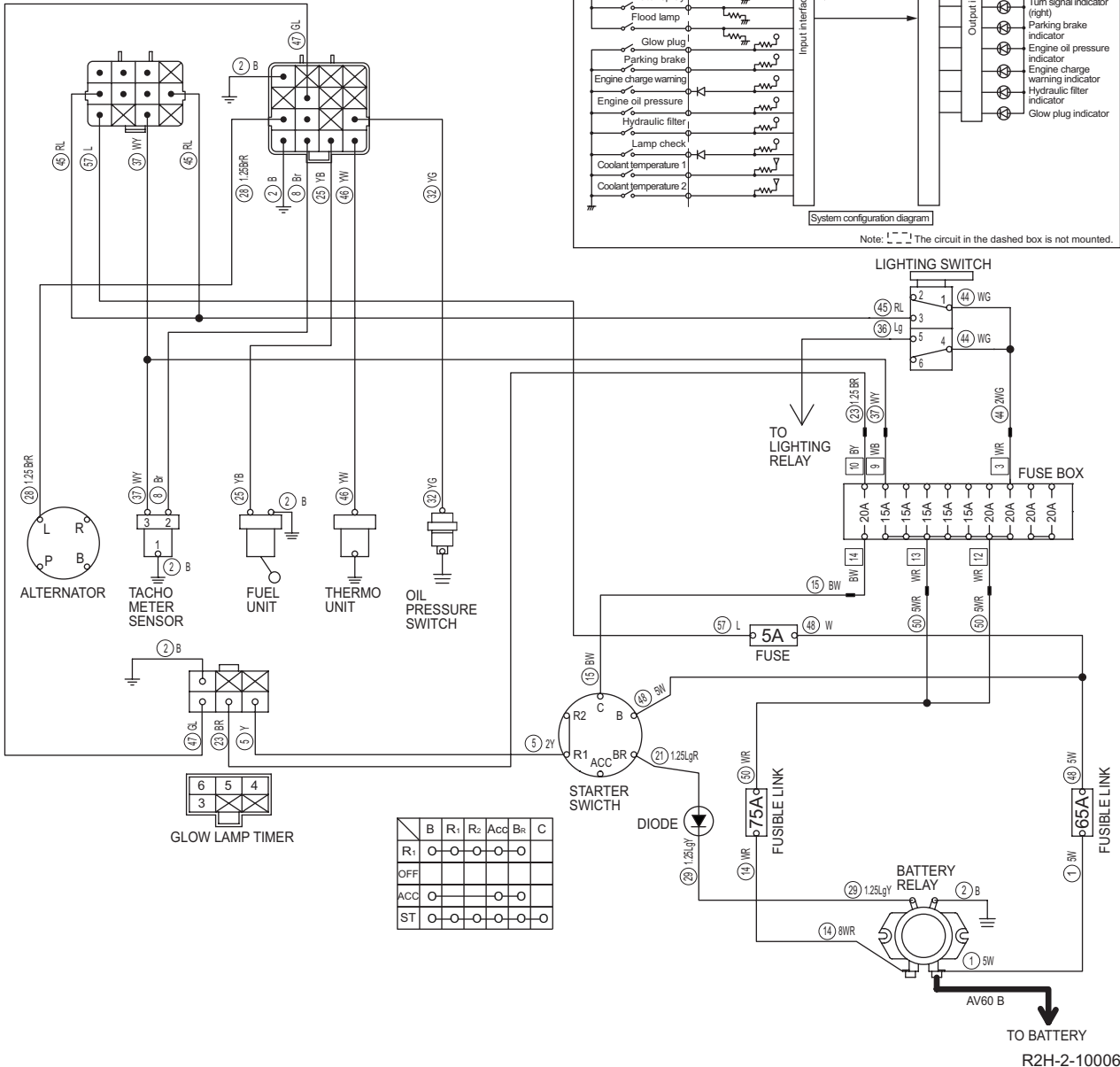

2-5-10. Tachometer reading is abnormal

Reference Fig. : 2-5-2

Check point	Check/Cause	Action
1. Combination Meter (Tachometer)	<p>(1) When starter switch is ON, measure voltage between combination meter terminal wires and ground terminal wire.</p> <ul style="list-style-type: none"> • Battery terminal wire No. 57 inlet wire L and ground terminal wire No.2 wire B • Starter switch terminal wire No. 37 inlet wire WY and ground terminal wire No.2 wire B <p>Standard voltage : 12 V or more</p> <p>(2) Check that combination meter terminal B wire (rev. ratio 3) are grounded.</p> <p>(3) Start engine and measure pulse between combination meter TA pulse terminal wire No. 8 inlet wire Br and chassis ground.</p> <p>Standard pulse : 38 pulses/rotation of engine</p> <ul style="list-style-type: none"> • If above items (1) and (2) are OK and pulse is NG in item (3), tacho meter sensor is faulty. • If above items (1) and (2) are OK and tachometer reading is NG in item (3), combination meter is faulty. 	Replace tachometer sensor or combination meter.
2. Harness Connecting Between Terminals	<ul style="list-style-type: none"> • Measure resistance of harness connecting between terminals. <p>Standard resistance : 10 Ω or less</p> <ul style="list-style-type: none"> • If resistance is abnormal, harness is faulty. 	Repair or replace harness.

2-5-11. Hour meter is abnormal

Reference Fig. : 2-5-2

Check point	Check/Cause	Action
1. Combination Meter (Hour meter)	<ul style="list-style-type: none"> • When starter switch is ON, measure voltage between combination meter terminal wires and ground terminal wire. • Battery terminal wire No. 57 inlet wire L and ground terminal wire No.2 wire B • Starter switch terminal wire No. 37 inlet wire WY and ground terminal wire No.2 wire B <p>Standard voltage : 12 V or more</p> <ul style="list-style-type: none"> • If no abnormality is found, combination meter is faulty. 	Replace combination meter.

Fig.: 2-5-2

COMBI.METER SET

38 PULS/REV SET			
REV RATIO SEL.			
1	2	3	4
OPEN	OPEN	GND	OPEN

TEMP. 50-103 °C SET	
TEMP.CURVE SEL.	
1	2
OPEN	OPEN

COMBINATION METER

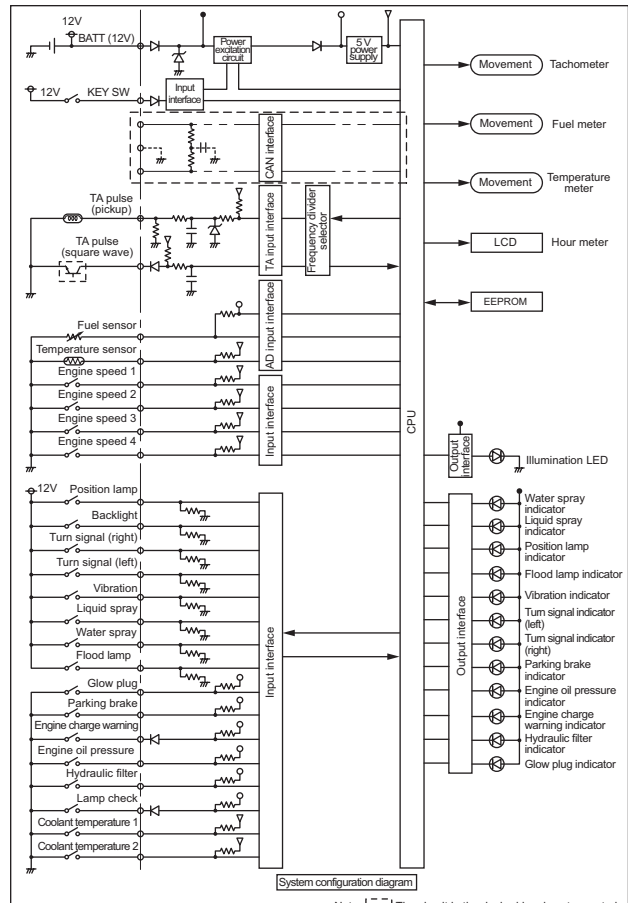
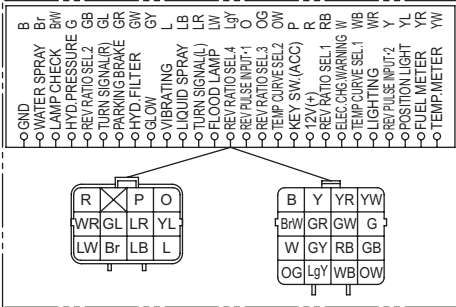

Note: L... The circuit in the dashed box is not mounted.

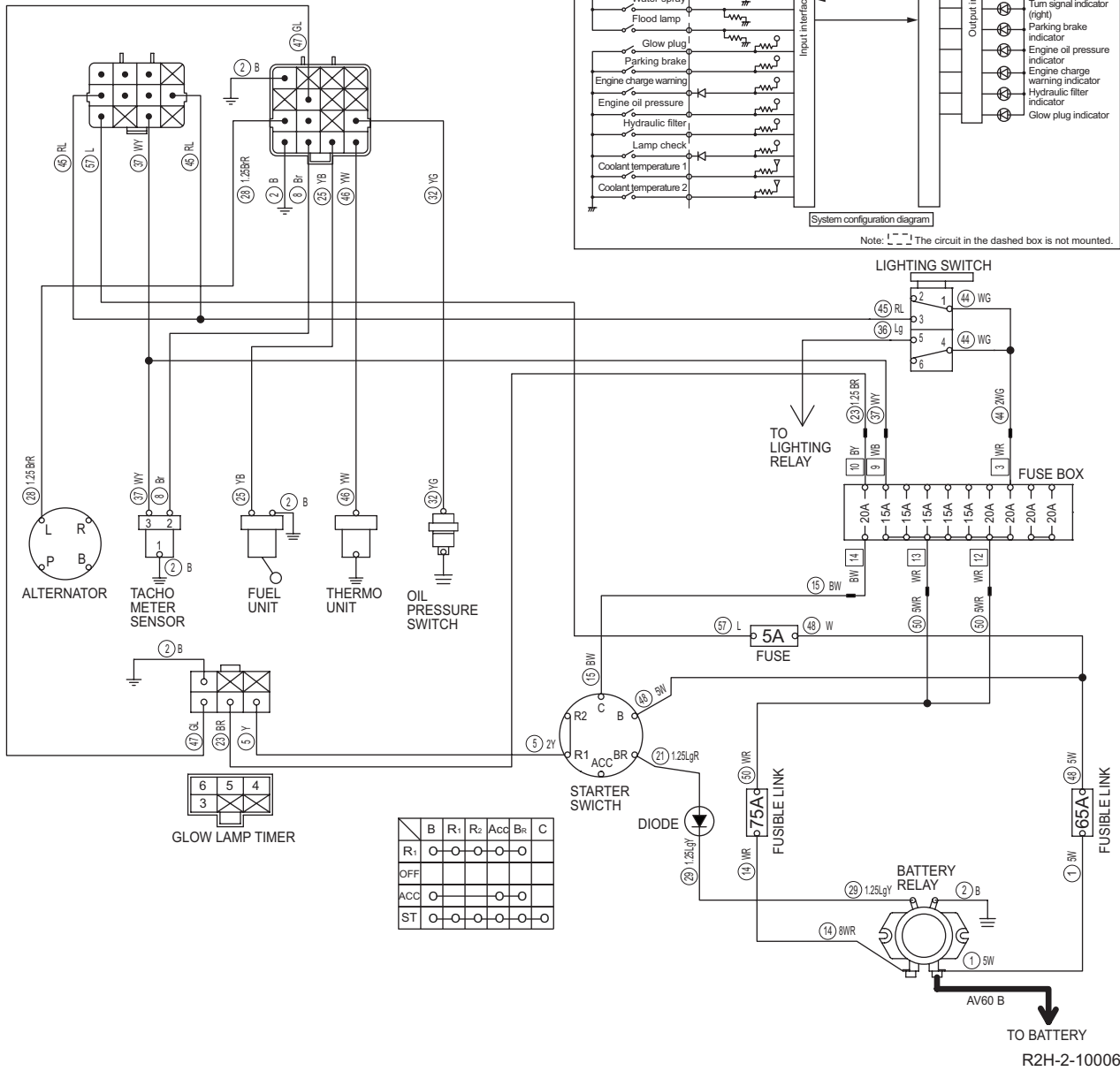

	B	R ₁	R ₂	Acc	Br	C
R ₁	O	O	O	O	O	O
OFF						
ACC	O					
ST	O	O	O	O	O	O

2-5-12. Temperature meter is abnormal

Reference Fig. : 2-5-2

Check point	Check/Cause	Action
1. Thermo Unit	<ul style="list-style-type: none"> • Disconnect harness and measure resistance of thermo unit. Standard resistance : 164.6 Ω [(at unit temperature of 50°C (122°F))] 26.44 Ω [(at unit temperature of 103°C (217°F))] • If resistance is abnormal, thermo unit is faulty. 	Replace thermo unit.
2. Combination Meter (Temperature meter)	<ul style="list-style-type: none"> • When starter switch is ON, measure voltage between combination meter terminal wires and ground terminal wire. <ul style="list-style-type: none"> • Battery terminal wire No. 57 inlet wire L and ground terminal wire No.2 wire B • Starter switch terminal wire No. 37 inlet wire WY and ground terminal wire No.2 wire B Standard voltage : 12 V or more • If no abnormality is found, combination meter is faulty. 	Replace combination meter.
3. Harness Connecting Between Terminals	<ul style="list-style-type: none"> • Measure resistance of harness connecting between terminals. Standard resistance : 10 Ω or less • If resistance is abnormal, harness is faulty. 	Repair or replace harness.

2-5-13. Fuel meter is abnormal

Reference Fig. : 2-5-2

Check point	Check/Cause	Action
1. Fuel Unit	<ul style="list-style-type: none"> • Disconnect harness and measure resistance of fuel unit. Standard resistance : 13.5 Ω (with float in Full position) 80.0 Ω (with float in Empty position) • If resistance is abnormal, fuel unit is faulty. 	Replace fuel unit.
2. Combination Meter (Fuel meter)	<ul style="list-style-type: none"> • When starter switch is ON, measure voltage between combination meter terminal wires and ground terminal wire. <ul style="list-style-type: none"> • Battery terminal wire No. 57 inlet wire L and ground terminal wire No.2 wire B • Starter switch terminal wire No. 37 inlet wire WY and ground terminal wire No.2 wire B Standard voltage: 12 V or more • If no abnormality is found, combination meter is faulty. 	Replace combination meter.
3. Harness Connecting Between Terminals	<ul style="list-style-type: none"> • Measure resistance of harness connecting between terminals. Standard resistance : 10 Ω or less • If resistance is abnormal, harness is faulty. 	Repair or replace harness.

Fig.: 2-5-2

COMBI.METER SET

38 PULS/REV SET			
REV RATIO SEL.			
1	2	3	4
OPEN	OPEN	GND	OPEN

TEMP. 50-103 °C SET	
TEMP.CURVE SEL.	
1	2
OPEN	OPEN

COMBINATION METER

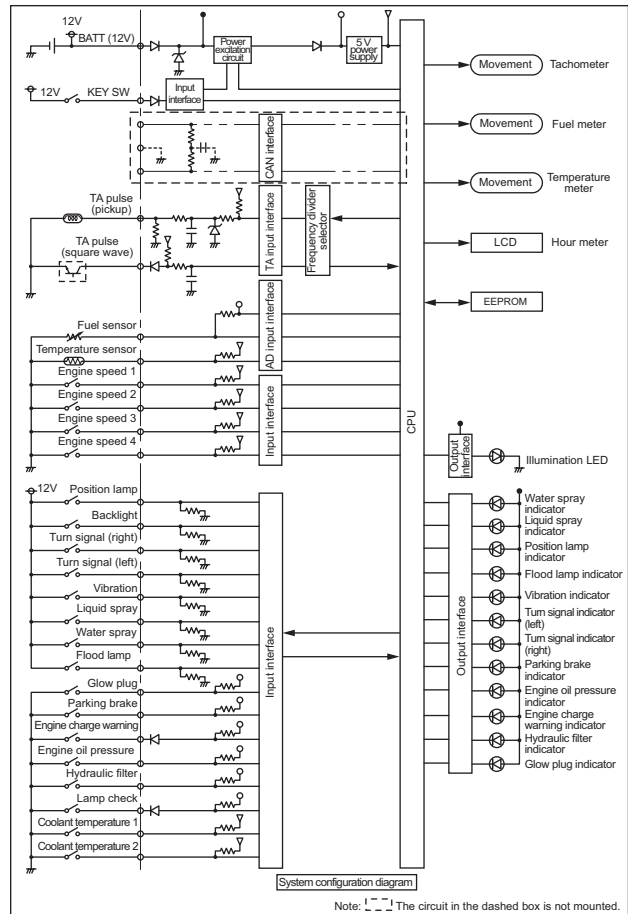
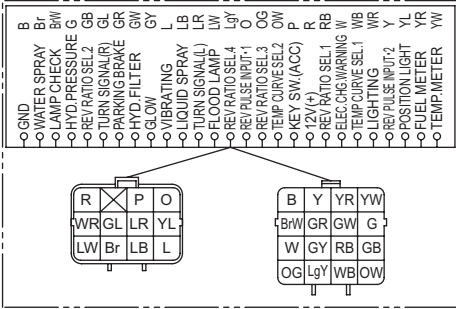

Note: L... The circuit in the dashed box is not mounted.

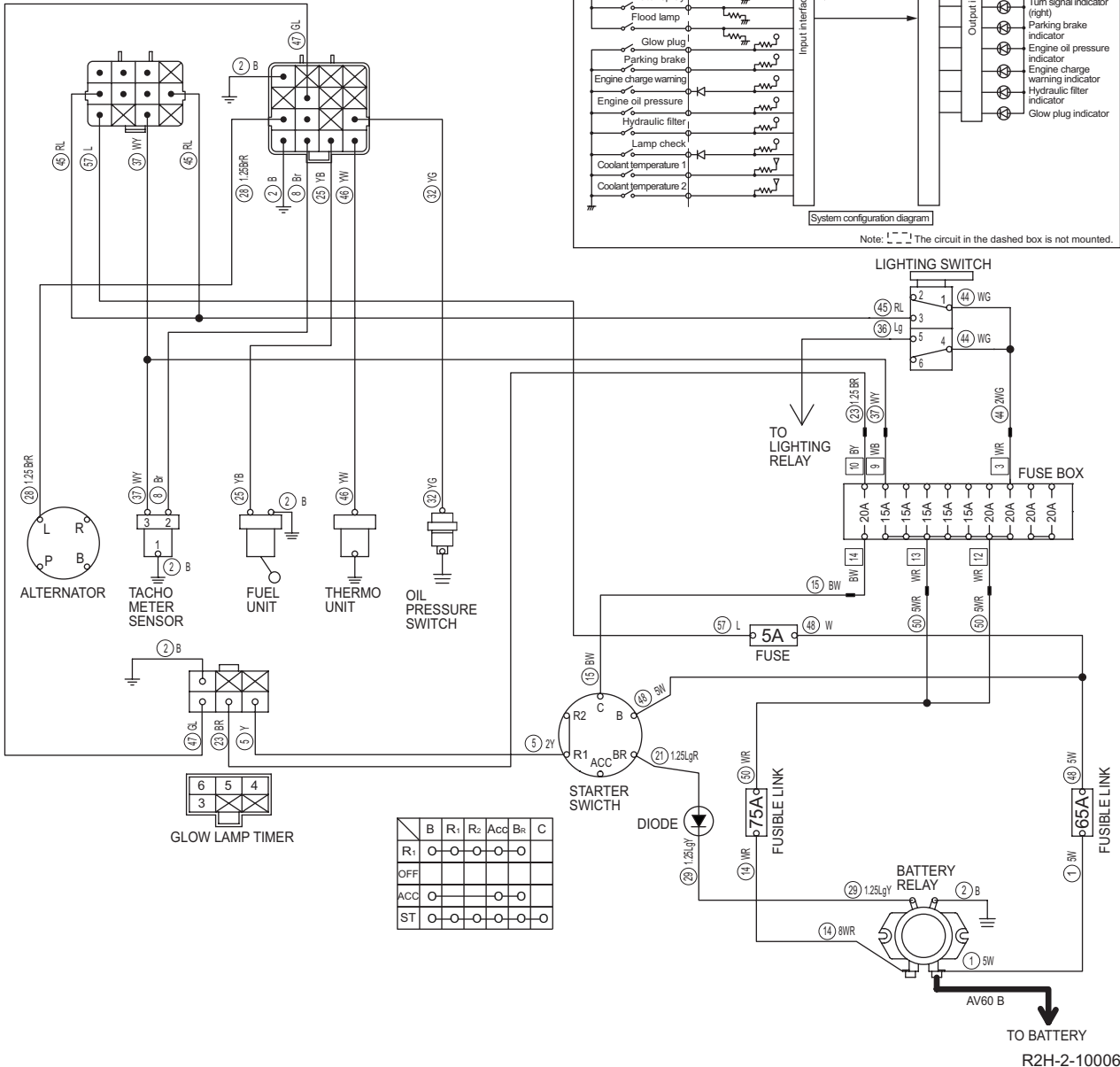

	B	R ₁	R ₂	Acc	Br	C
R ₁	O	O	O	O	O	
OFF						
ACC	O			O	O	
ST	O	O	O	O	O	

2-5-14. Charge warning lamp remains ON

- Check with engine running.

Reference Fig. : 2-5-2

Check point	Check/Cause	Action
1. Harness	<ul style="list-style-type: none"> • Disconnect connectors between alternator terminal L and combination meter. • Measure resistance between terminals and chassis ground. <ul style="list-style-type: none"> • Alternator terminal L and chassis ground • Charge warning lamp terminal wire No. 28 wire BrR and chassis ground Standard resistance : 100k Ω or more • If resistance is abnormal, harness is faulty. 	Repair or replace harness.
2. Combination Meter (Charge warning)	<ul style="list-style-type: none"> • Measure voltage between combination meter charge warning lamp terminal outlet wire No. 28 wire BrR and chassis ground. <ul style="list-style-type: none"> Standard voltage : 12 V or more • If voltage is OK, combination meter is faulty. • If voltage is abnormal, alternator is faulty. 	Replace combination meter or alternator.

2-5-15. Oil pressure warning lamp remains ON

Reference Fig. : 2-5-2

Check point	Check/Cause	Action
1. Harness	<ul style="list-style-type: none"> • Disconnect connectors between oil pressure switch and combination meter. • Measure resistance between oil pressure switch terminal wire YG and chassis ground. • Combination meter connector terminal wire No.32 wire YG and chassis ground. <ul style="list-style-type: none"> Standard resistance : 100k Ω or more • If resistance is abnormal, harness is faulty. 	Repair or replace harness.
2. Oil Pressure Switch	<ul style="list-style-type: none"> • Disconnect oil pressure switch and check continuity between its terminals. <ul style="list-style-type: none"> There is continuity in normal condition. • If there is no continuity, oil pressure switch is faulty. 	Replace oil pressure switch.
3. Combination Meter (Oil pressure warning)	<p>(1) When starter switch is ON, measure voltage between combination meter terminal wires and ground terminal wire.</p> <ul style="list-style-type: none"> • Battery terminal wire No. 57 inlet wire L and ground terminal wire No.2 wire B. • Starter switch terminal wire No.37 inlet wire WY and ground terminal wire No.2 wire B. <p>Standard voltage : 12 V or more</p> <p>(2) When starter switch is ON, measure voltage between combination meter oil pressure warning lamp terminal wire No.32 outlet wire YG and chassis ground.</p> <p>Standard voltage : 12 V or more</p> <ul style="list-style-type: none"> • If above items (1) and (2) are OK and no abnormality is found in oil pressure switch but oil pressure warning lamp remains ON after starting engine, combination meter is faulty. 	Replace combination meter.

Fig.: 2-5-3

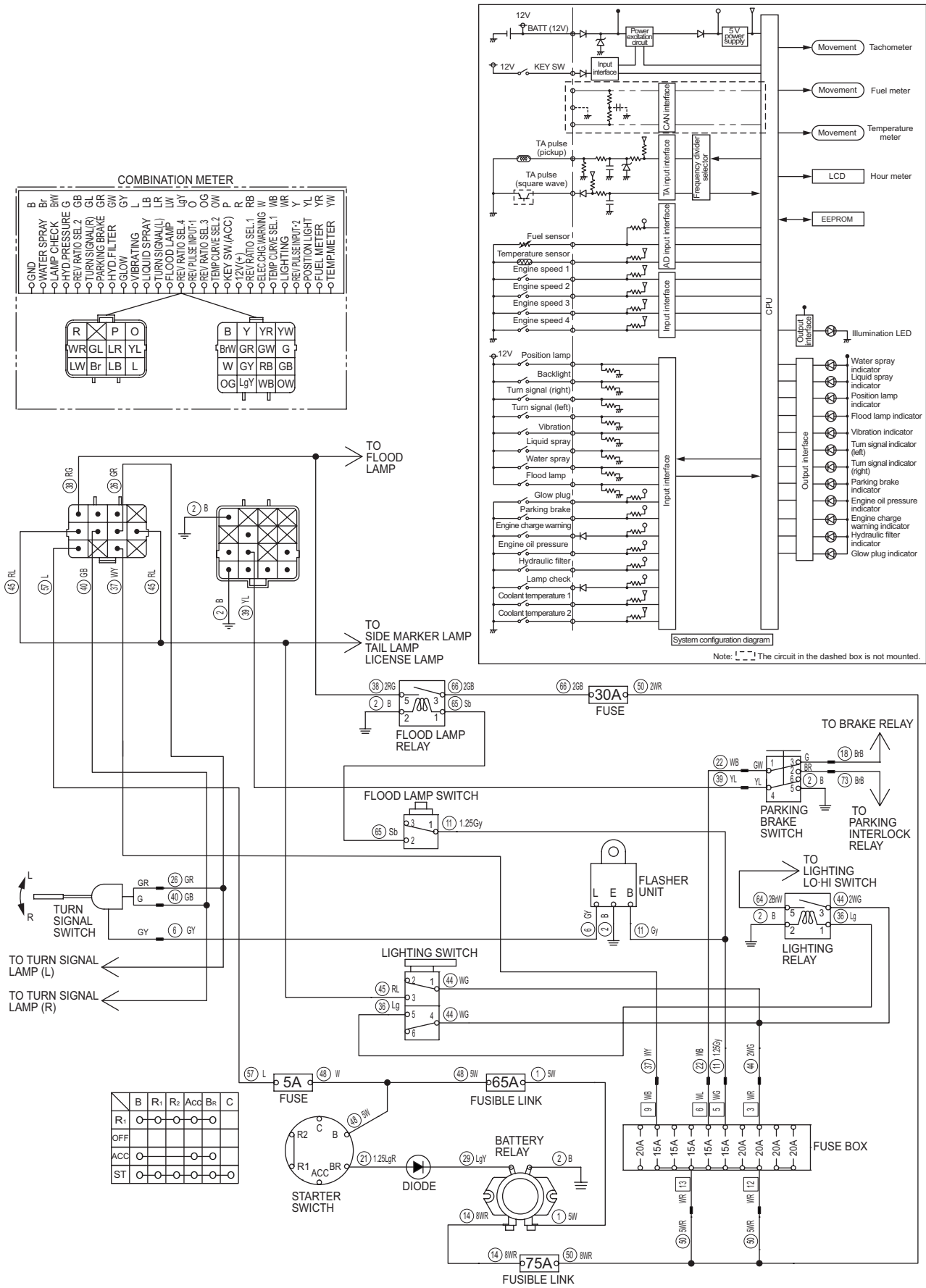

2-5-16. Parking brake indicator lamp does not light

Reference Fig. : 2-5-3

Check point	Check/Cause	Action
1. Harness	<ul style="list-style-type: none"> • Measure resistance between parking brake switch terminal 4 wire YL and combination meter connector terminal wire No. 39 wire YL. Standard resistance : 10 Ω or less • If resistance is abnormal, harness is faulty. 	Repair or replace harness.
2. Parking Brake Switch	<ul style="list-style-type: none"> • When parking brake is applied, check continuity between parking brake switch terminal 4 and 5. There is continuity in normal condition. • If there is no continuity, parking brake switch is faulty. 	Replace parking brake switch.
3. Combination Meter (Parking brake indicator)	<p>(1) When starter switch is ON, measure voltage between combination meter terminal wires and ground terminal wire.</p> <ul style="list-style-type: none"> • Battery terminal wire No. 57 inlet wire L and ground terminal wire No.2 wire B • Starter switch terminal wire No. 37 inlet wire WY and ground terminal wire No.2 wire B <p>Standard voltage : 12 V or more</p> <p>(2) When starter switch is ON and parking brake is applied, measure voltage between combination meter parking brake indicator lamp terminal wire No.39 outlet wire YL and chassis ground.</p> <p>Standard voltage : 12 V or more</p> <ul style="list-style-type: none"> • If above items (1) and (2) are OK and parking brake indicator lamp does not light, combination meter is faulty. 	Replace combination meter.

Fig.: 2-5-4

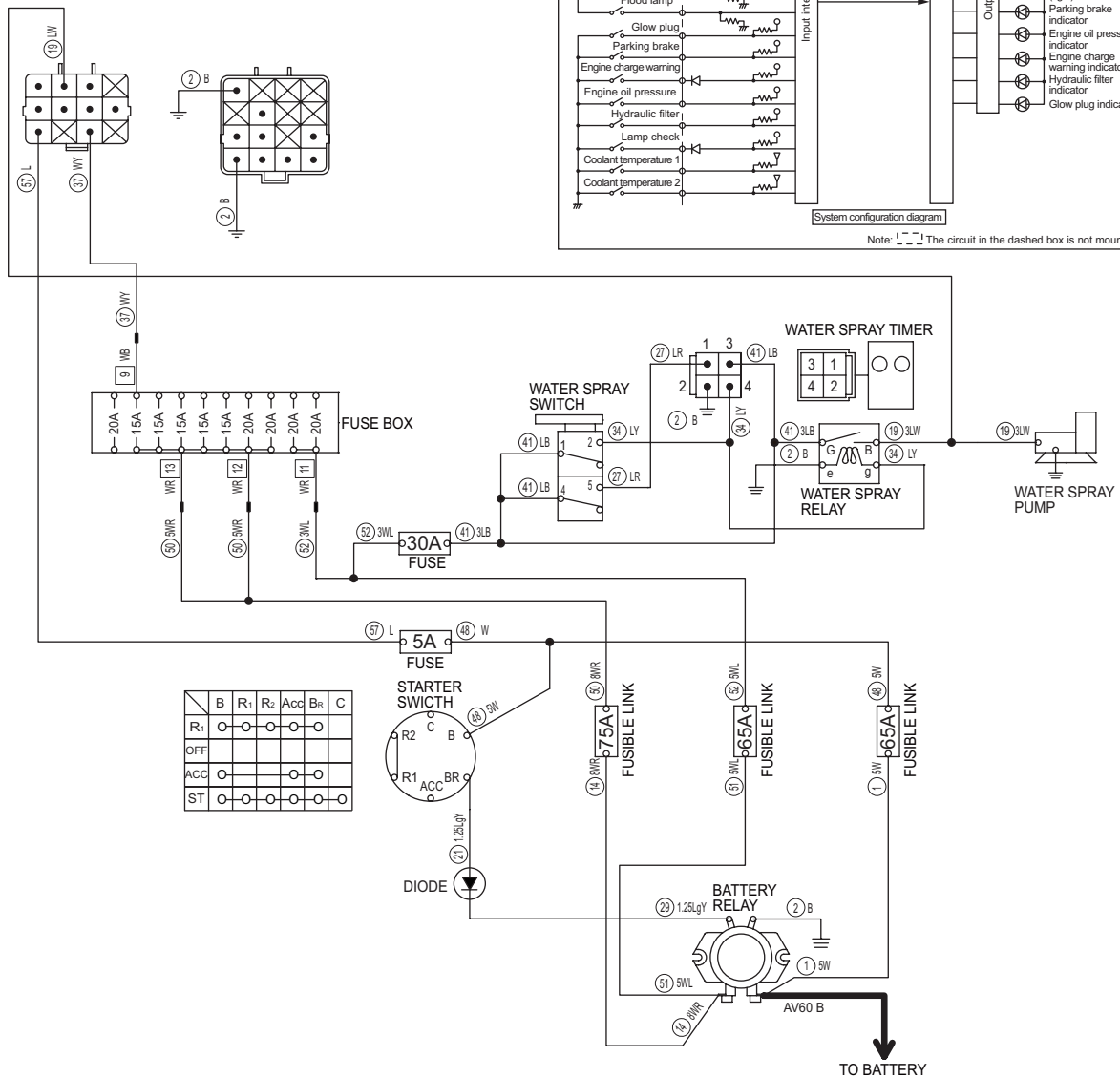
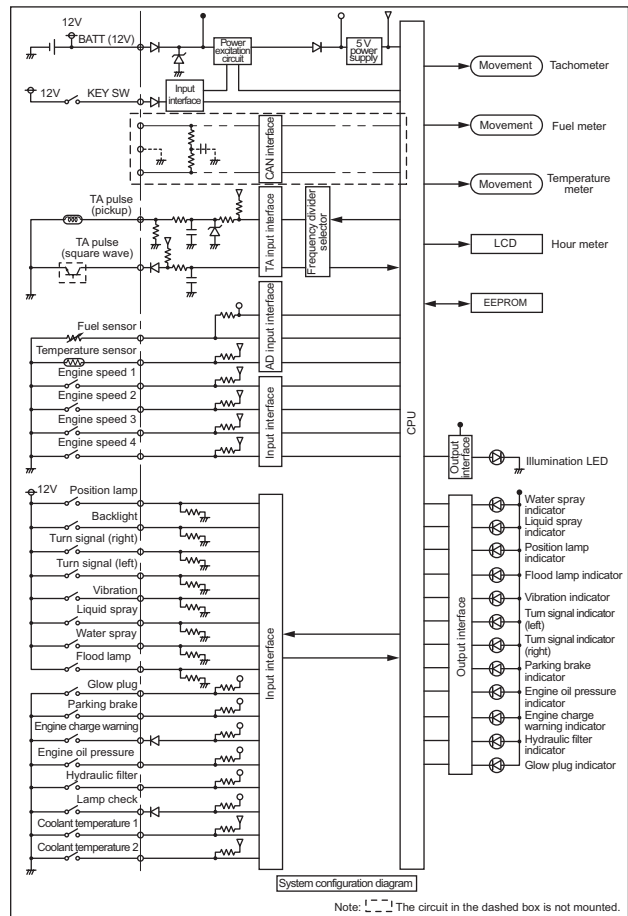
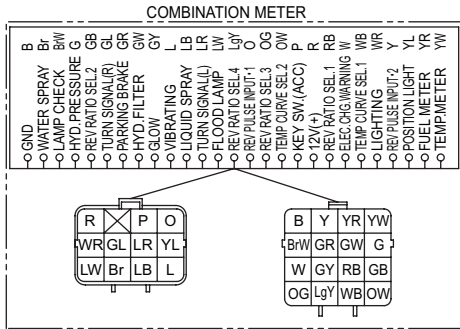

	B	R ₁	R ₂	Acc	Br	C
R ₁	○	○	○	○	○	○
OFF						
ACC	○					
ST	○	○	○	○	○	○

2-5-17. Water spray indicator lamp does not light

- Check that water spray pump can be operated.

Reference Fig.: 2-5-4

Check point	Check/Cause	Action
1. Harness	<ul style="list-style-type: none"> • Measure resistance between water spray relay terminal B wire LW and combination meter connector terminal wire No.19 wire LW. Standard resistance: 10 Ω or less • If resistance is abnormal, harness is faulty. 	Repair or replace harness.
2. Combination Meter (Water spray indicator)	<p>(1) When starter switch is ON, measure voltage between combination meter terminal wires and ground terminal wire.</p> <ul style="list-style-type: none"> • Battery terminal wire No. 57 inlet wire L and ground terminal wire No.2 wire B • Starter switch terminal wire No. 37 inlet wire WY and ground terminal wire No.2 wire B <p>Standard voltage: 12 V or more</p> <p>(2) When starter switch is ON and water spray switch is ON, measure voltage between combination meter water spray indicator lamp terminal wire No. 19 inlet wire LW and chassis ground.</p> <p>Standard voltage: 12 V or more</p> <ul style="list-style-type: none"> • If above items (1) and (2) are OK and water spray indicator lamp does not turn on, combination meter is faulty. 	Replace combination meter.

Fig.: 2-5-3

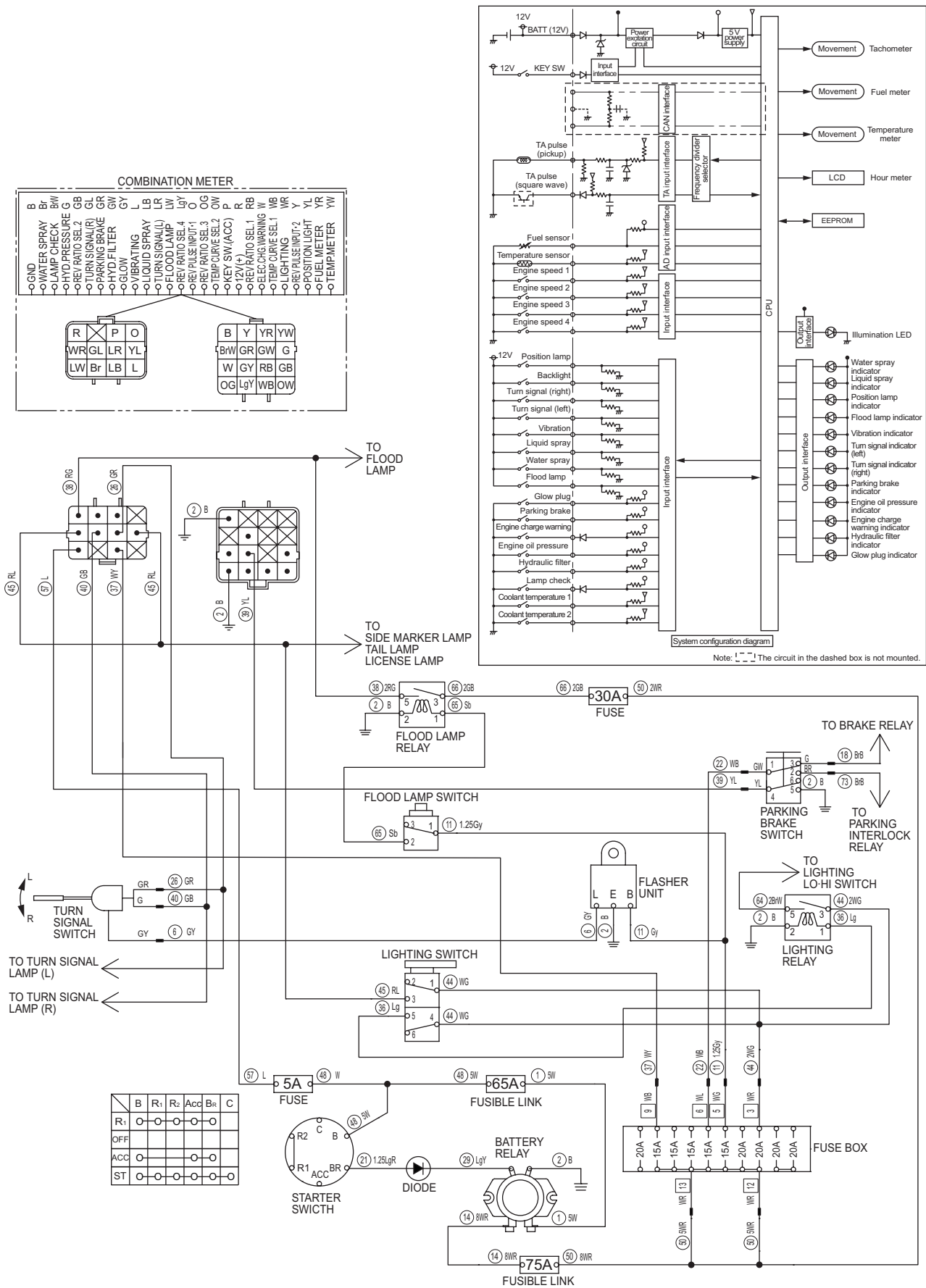

2-5-18. Flood lamp indicator lamp does not light

- Check that flood lamp lights.

Reference Fig. : 2-5-3

Check point	Check/Cause	Action
1. Harness	<ul style="list-style-type: none"> • Measure resistance between flood lamp relay terminal 5 wire RG and combination meter connector terminal wire No. 38 wire RG. Standard resistance : 10 Ω or less • If resistance is abnormal, harness is faulty. 	Repair or replace harness.
2. Combination Meter (Flood lamp indicator)	<p>(1) When starter switch is ON, measure voltage between combination meter terminal wires and ground terminal wire.</p> <ul style="list-style-type: none"> • Battery terminal wire No. 57 inlet wire L and ground terminal wire No.2 wire B • Starter switch terminal wire No. 37 inlet wire WY and ground terminal wire No.2 wire B <p>Standard voltage : 12 V or more</p> <p>(2) When starter switch is ON and flood lamp switch is ON, measure voltage between combination meter flood lamp indicator lamp terminal wire No.38 inlet wire RG and chassis ground.</p> <p>Standard voltage : 12 V or more</p> <ul style="list-style-type: none"> • If above items (1) and (2) are OK and flood lamp indicator lamp does not light, combination meter is faulty. 	Replace combination meter.

2-5-19. Side marker lamp indicator lamp does not light

- Check that head lamp, side marker lamp, tail lamp and license lamp light.

Reference Fig.: 2-5-3

Check point	Check/Cause	Action
1. Harness	<ul style="list-style-type: none"> • Measure resistance between lighting switch terminal 3 wire RL and combination meter connector terminal wire No.45 wire RL. Standard resistance value: 10 Ω or lower. • If above resistance value is abnormal, harness is faulty. 	Repair or replace harness.
2. Combination Meter (Side marker lamp indicator)	<p>(1) When starter switch is ON, measure voltage between combination meter terminal wires and ground terminal wire.</p> <ul style="list-style-type: none"> • Battery terminal wire No. 57 inlet wire L and ground wire No.2 wire B • Starter switch terminal wire No. 37 inlet wire WY and ground wire No.2 wire B <p>Standard voltage: 12 V or more</p> <p>(2) When starter switch is ON and lighting switch is “”, measure voltage between combination meter side marker lamp indicator lamp terminal wire No. 45 inlet wire RL and chassis ground.</p> <p>Standard voltage: 12 V or more</p> <ul style="list-style-type: none"> • If above (1) and (2) are OK and side marker lamp indicator lamp does not turn on, combination meter is faulty. 	Replace combination meter.

Fig.: 2-5-3



2-5-20. Turn signal indicator lamp does not light

Reference Fig.: 2-5-3

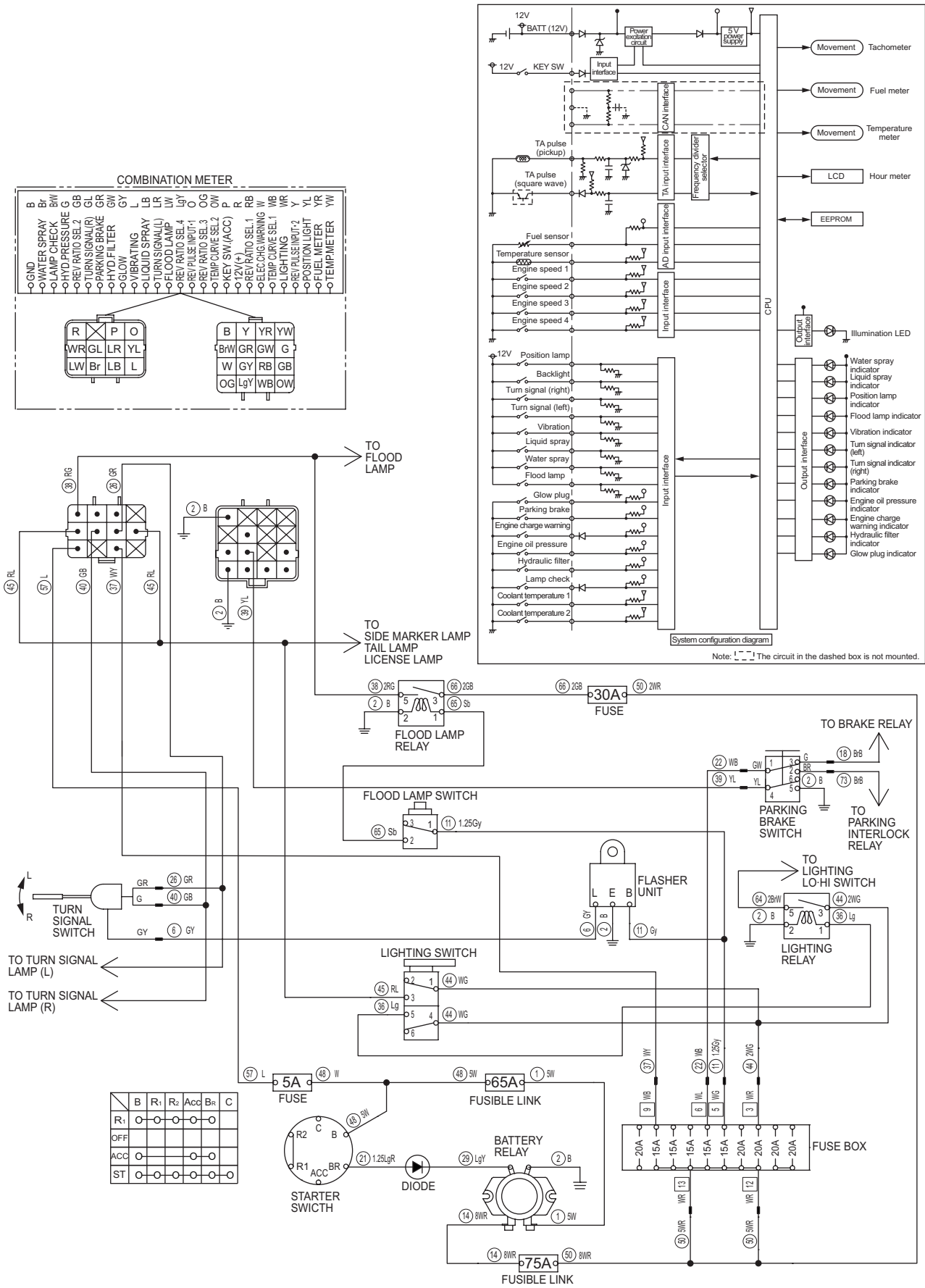
Check point	Check/Cause	Action
1. Harness	(1) Measure resistance between turn signal switch terminal wire GR (left-hand side) and combination meter connector terminal wire No.26 wire GR. Standard resistance: 10 Ω or less (2) Measure resistance between turn signal switch terminal wire GB (right-hand side) and combination meter connector terminal wire No.40 wire GB. Standard resistance: 10 Ω or less • If item (1) or (2) is NG, harness is faulty.	Repair or replace harness.
2. Turn Signal Switch	• Check continuity between turn signal switch terminals while turn signal switch is ON. Direction indicator switch: To the left: Between wire GY and GR To the right: Between wire GY and GB There is continuity in normal condition. • If there is no continuity, turn signal switch is faulty.	Replace turn signal switch.
3. Combination Meter (Turn signal indicator)	(1) When starter switch is ON, measure voltage between combination meter terminal wires and ground terminal wire. • Battery terminal wire No. 57 inlet wire L and ground terminal wire No.2 wire B • Starter switch terminal wire No. 37 inlet wire WY and ground terminal wire No.2 wire B Standard voltage : 12 V or more (2) When starter switch is ON and turn signal switch is ON, measure voltage between combination meter terminal wires and chassis ground. • Left-hand side turn signal indicator lamp terminal wire No.26 inlet wire GR and chassis ground • Right-hand side turn signal indicator lamp terminal wire No.40 inlet wire GB and chassis ground Standard voltage : 12 V or more • If above item (1) and (2) are OK and turn signal indicator lamp does not turn on, combination meter is faulty.	Replace combination meter.

2-5-21. Glow (Preheating plug) indicator lamp does not light

Reference Fig. : 2-5-5

Check point	Check/Cause	Action
1. Harness	(1) Measure resistance between glow lamp timer terminal 6 wire GL and combination meter connector terminal wire No.47 wire GL. Standard resistance: 10 Ω or less (2) Measure resistance between glow lamp timer terminal 4 wire Y and starter switch terminal R1 wire Y. Standard resistance: 10 Ω or less (3) Measure resistance between glow lamp timer terminal 5 wire BR and fuse box terminal 10 wire BR. Standard resistance: 10 Ω or less • If item (1), (2) or (3) is NG, harness is faulty.	Repair or replace harness.
2. Glow Lamp Timer	(1) When starter switch is HEAT, measure voltage between glow lamp timer terminal 4 inlet wire Y and chassis ground. Standard voltage : 12 V or more (2) When starter switch is START, measure voltage between glow lamp timer terminal wires and chassis ground. • Glow lamp timer terminal 4 inlet wire Y and chassis ground • Glow lamp timer terminal 5 inlet wire BR and chassis ground Standard voltage : 12 V or more (3) When starter switch is HEAT, measure voltage between glow lamp timer terminal 6 inlet wire GL and chassis ground. Standard voltage : 12 V or more (Electricity flows for a definite time.) • If items (1) and (2) are OK and item (3) is NG, glow lamp timer is faulty.	Replace glow lamp timer.
3. Combination Meter (Glow indicator)	(1) When starter switch is ON, measure voltage between combination meter terminal wires and ground terminal wire. • Battery terminal wire No. 57 inlet wire L and ground terminal wire No.2 wire B. • Starter switch terminal wire No.37 inlet wire WY and ground terminal wire No.2 wire B. Standard voltage : 12 V or more (2) When starter switch is HEAT, measure voltage between combination meter glow indicator lamp terminal wire No. 47 outlet wire GL and ground terminal wire No.2 wire B. Standard voltage : 12 V or more (Electricity flows for a definite time.) • If above items (1) and (2) are OK and glow indicator lamp does not light, combination meter is faulty.	Replace combination meter.

Fig. : 2-5-1

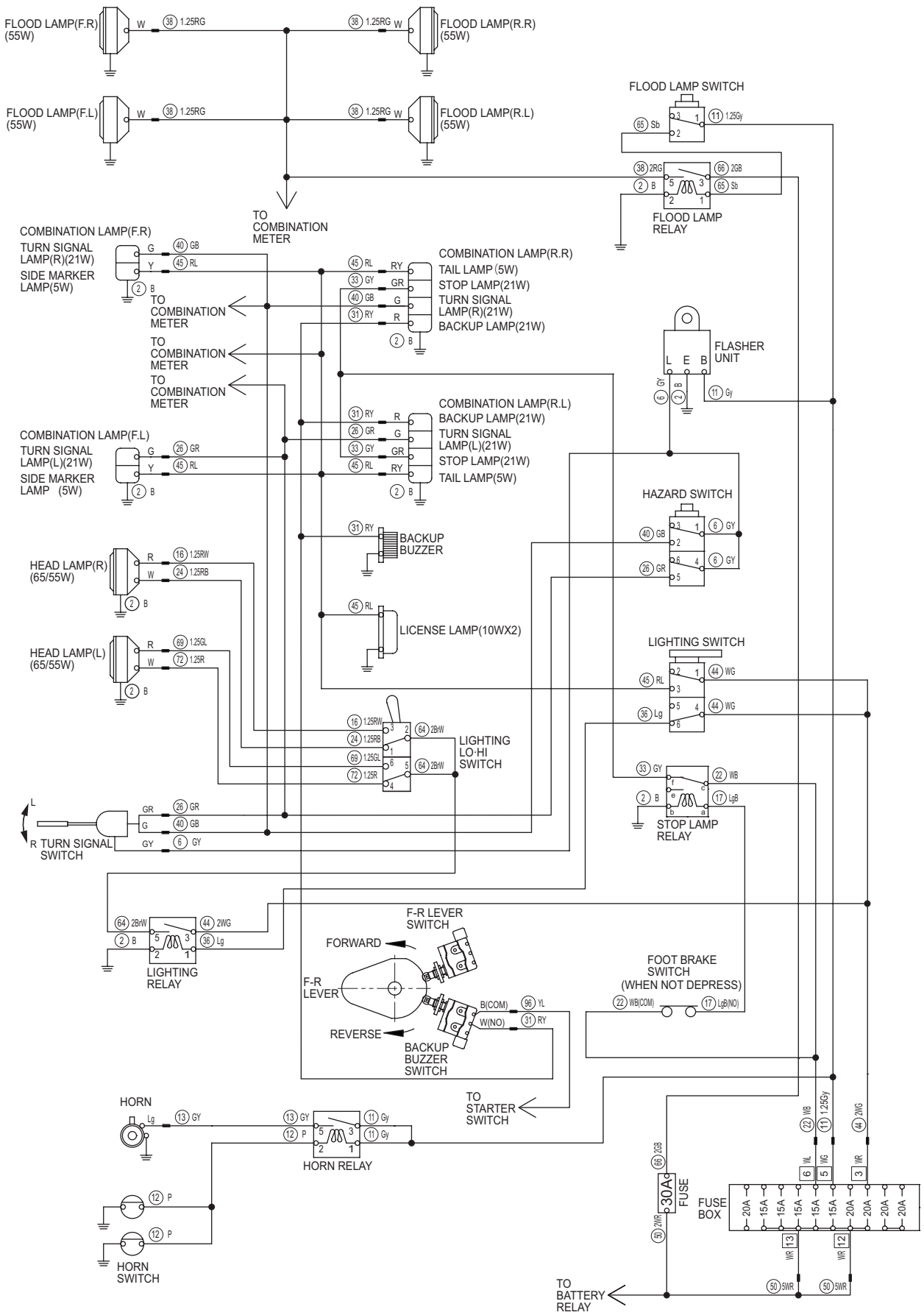

2-5-22. Horn does not sound

Reference Fig. : 2-5-1

Check point	Check/Cause	Action
1. Horn	<ul style="list-style-type: none"> • Disconnect horn and directly connect battery positive terminal to horn terminal wire Lg side and negative terminal to horn terminal chassis ground side. • If horn does not sound, horn is faulty. 	Replace horn.
2. Horn Relay	<p>(1) When starter switch is ON and horn switch is pressed, measure voltage between horn relay terminal 2 outlet wire P and chassis ground. Standard voltage : 12 V or more</p> <p>(2) When starter switch is ON and horn switch is pressed, measure voltage between horn relay terminal 5 outlet wire GY and chassis ground. Standard voltage : 12 V or more</p> <ul style="list-style-type: none"> • If above item (1) is OK and item (2) is NG, horn relay is faulty. 	Replace horn relay.
3. Horn Switch	<ul style="list-style-type: none"> • When horn switch is OFF, measure resistance between horn switch terminals. Standard resistance : 100 kΩ or more • If resistance is abnormal, horn switch is faulty. 	Replace horn switch.
4. Harness Connecting Between Terminals	<ul style="list-style-type: none"> • Measure resistance of harness connecting between terminals. Standard resistance : 10 Ω or less • If resistance is abnormal, harness is faulty. 	Repair or replace harness.

2-5-23. Backup buzzer does not sound

Reference Fig. : 2-5-1

Check point	Check/Cause	Action
1. Backup Buzzer	<ul style="list-style-type: none"> • Disconnect backup buzzer and directly connect battery positive terminal to backup buzzer terminal wire RY side and negative terminal to backup buzzer terminal chassis ground side. • If backup buzzer does not sound, backup buzzer is faulty. 	Replace backup buzzer.
2. Backup Buzzer Switch	<p>(1) When starter switch is ON, measure voltage between backup buzzer switch terminal COM inlet wire YL and chassis ground. Standard voltage : 12 V or more</p> <p>(2) When starter switch is ON and F-R lever is in reverse, measure voltage between backup buzzer switch terminal NO outlet wire RY and chassis ground. Standard voltage : 12 V or more</p> <ul style="list-style-type: none"> • If above item (1) is OK and item (2) is NG, backup buzzer switch is faulty. 	Replace backup buzzer switch.
3. Harness Connecting Between Terminals	<ul style="list-style-type: none"> • Measure resistance of harness connecting between terminals. Standard resistance : 10 Ω or less • If resistance is abnormal, harness is faulty. 	Repair or replace harness.

3. HYDRAULIC SYSTEM TROUBLESHOOTING

3-1. When Performing Hydraulic System Troubleshooting

- The largest factor in the majority of failures of hydraulic devices operating under conditions of higher pressure and greater precision is the entry of dirt (foreign substances) into the hydraulic circuit. Particular caution is required when supplying hydraulic oil or when disassembling and assembling hydraulic devices.

1) Pay attention to the work environment.

As much as possible, avoid performing tasks such as supplying hydraulic oil, replacing filters and repair work on rainy days, when there is strong wind, or in locations where there is much dust.

2) Disassembly and maintenance work in the field

There is the danger of dust entry when disassembly and maintenance work for hydraulic components is performed in the field. In addition, because performance verification after repairs are completed is difficult, replacement of the entire assembly is preferred. Perform disassembly and maintenance of hydraulic components in a special room protected from dust, and use special testers to verify the performance.

3) Sealing of openings

Use caps, tape, plastic bags or other means to seal the openings of removed pipes and components in order to prevent foreign substances from entering. Never leave the openings exposed or put a shop cloth into them. There is the danger of foreign substances entering or of leaking oil causing environmental contamination.

Do not dispose of waste oil on-site. Either deliver it to the customer and request disposal or take it back with you and dispose of it.

4) Prevent entry of foreign substances when supplying oil.

Take care that foreign substances do not enter when supplying hydraulic oil. Clean the oil supply port and the area around it, as well as the supply pump, oilcan and other items. A more reliable method is to use oil cleaning equipment, which can filter out the contamination that occurred during storage.

5) Change hydraulic oil while the temperature is still high.

All oils, including hydraulic oil, flow more readily when they are warm. Higher temperatures also make it easier to eject the sludge and other substances outside the circuit together with the oil. For these reasons, oil changes should be performed while the oil temperature is high. When changing the oil, it is necessary to drain out as much of the old hydraulic oil as possible. (In addition to the hydraulic oil tank, also drain the oil from the filter and circuit drain plugs.) If old hydraulic oil remains in the system, the contaminants and sludge in the old oil will mix with the new oil and shorten the hydraulic oil lifetime.

3-2. Propulsion System

If a problem occurs in propulsion systems such as propulsion pump, propulsion motor and brakes, determine the cause and carry out action as required, according to following general troubleshooting items.

(NOTICE)

- When checking whether or not the pressure is correct, refer to the pressure standard value for each hydraulic circuit.

3-2-1. Machine moves neither forward nor backward 1/2

Check point	Cause	Check/Action
1. Oil Level of Hydraulic Oil Tank	Oil level in hydraulic oil tank is low.	Fill tank until correct oil level is obtained.
2. Bypass Valve	Bypass valve is open.	Close bypass valve.
3. F-R Lever Linkage	F-R lever linkage is faulty.	Check and adjust F-R lever linkage or replace it if necessary.
4. Charge Circuit Pressure	Propulsion pump does not discharge oil because charge pressure is low.	<ul style="list-style-type: none"> • Measure charge pressure. • If low, check and adjust charge relief valve or replace it if necessary.
	Insufficient charge pump discharge.	Repair charge pump or replace it if necessary.
	Charge pressure decreases due to internal leakage of solenoid valve connecting oil supply circuit with charge circuit. <ul style="list-style-type: none"> • Parking brake solenoid valve • Speed change solenoid valve 	<ul style="list-style-type: none"> • When solenoid is energized, check if oil flows in return circuit to tank. • If oil is flowing, repair solenoid valve or replace it if necessary.
5. Servo Bypass Solenoid Valve	If spool of servo bypass solenoid valve is stuck, pressure in both sides of servo cylinder chamber is equalized. This causes propulsion pump unable to discharge oil.	<ul style="list-style-type: none"> • Measure pressure in servo cylinder chambers. • If pressure is equal in both chambers, repair servo bypass solenoid valve or replace it if necessary.
6. Suction Filter for Charge Pump	Charge pump flow is reduced due to clogged filter.	Clean suction filter or replace it if necessary.
7. Propulsion Circuit Pressure	Circuit does not obtain required pressure because setting pressure of high pressure relief is low.	<ul style="list-style-type: none"> • Measure propulsion circuit pressure. • If low, check and adjust multifunction valve or replace it if necessary.
8. Propulsion Motor	Propulsion circuit pressure is not held in propulsion motor case.	If pressure in propulsion motor case is not within allowable range, repair propulsion motor or replace it if necessary.
	Internal leakage of propulsion motor.	<ul style="list-style-type: none"> • Measure drain quantity from propulsion motor. • If drain quantity is larger than standard value, repair propulsion motor or replace it if necessary.
	Sticking of disc brakes causes brakes to remain applied.	Replace disc brakes.

TROUBLESHOOTING

3-2-1. Machine moves neither forward nor backward 2/2

Check point	Cause	Check/Action
9. Propulsion Pump	Discharge flow rate is insufficient due to efficiency degradation of propulsion pump.	<ul style="list-style-type: none"> • Measure discharge flow rate of propulsion pump with flow meter. • If discharge flow rate is not within specified range, repair propulsion pump or replace it if necessary.
	Discharge flow rate is insufficient due to wear of propulsion pump drive shaft splines.	Replace propulsion pump.
	Propulsion circuit pressure is not held in propulsion pump case.	If pressure in propulsion pump case is not within allowable range, repair propulsion pump or replace it if necessary.
10. Parking Brake Solenoid Valve	Brake remains applied because spool of parking brake solenoid valve does not shift.	Repair parking brake solenoid valve or replace it if necessary.
11. Brake Inlet Pressure	Brake cannot be released because brake inlet pressure is low.	<ul style="list-style-type: none"> • Measure brake release pressure. • If low, repair propulsion motor, or replace it if necessary.
12. Flange	Drive torque is not transmitted to pump due to faulty flange.	Replace flange.

3-2-2. Machine moves in one direction only (forward or backward)

Check point	Cause	Check/Action
1. F-R Lever Linkage	F-R lever linkage is faulty.	Check and adjust F-R lever linkage or replace it if necessary.
2. Multifunction Valve	Low circuit pressure due to incorrect high pressure relief setting or internal leakage of multifunction valve.	<ul style="list-style-type: none"> • Interchange two multifunction valves. • If faulty condition is accordingly reversed, check and adjust multifunction valve or replace it if necessary.

3-2-3. Slow machine speed or small drive force 1/2

Check point	Cause	Check/Action
1. Bypass Valve	Bypass valve is slightly open.	Close bypass valve completely.
2. F-R Lever Linkage	F-R lever linkage is faulty.	Check and adjust F-R lever linkage or replace it if necessary.
3. Charge Circuit Pressure	Stroke of propulsion pump swash plate is small because charge pressure is low, decreasing discharge rate of propulsion pump.	<ul style="list-style-type: none"> • Measure charge pressure. • If low, check and adjust charge relief valve or replace it if necessary.
	Insufficient charge pump discharge.	Repair charge pump or replace it if necessary.
	Charge pressure decreases due to internal leakage of solenoid valve connecting oil supply circuit with charge circuit. <ul style="list-style-type: none"> • Parking brake solenoid valve • Speed change solenoid valve 	<ul style="list-style-type: none"> • When solenoid is energized, check if oil flows in return circuit to tank. • If oil is flowing, repair solenoid valve or replace it if necessary.
4. Suction Filter for Charge Pump	Flow rate of charge pump decreases as well as charge pressure decreases due to clogged filter.	Clean suction filter or replace it if necessary.

3-2-3. Slow machine speed or small drive force 2/2

Check point	Cause	Check/Action
5. Propulsion Motor	Propulsion motor inlet pressure is low.	<ul style="list-style-type: none"> • Measure propulsion motor inlet pressure. • If low, check and adjust multifunction valve or replace it if necessary.
	Propulsion circuit pressure is not held in propulsion motor case.	If pressure in propulsion motor case is not within allowable range, repair propulsion motor or replace it if necessary.
	Output of propulsion motor decreases and number of revolutions decreases due to internal leakage of propulsion motor.	<ul style="list-style-type: none"> • Measure drain quantity from propulsion motor. • If drain quantity is larger than standard value, repair propulsion motor or replace it if necessary.
6. Propulsion Pump	Discharge flow rate is insufficient due to efficiency degradation of propulsion pump.	<ul style="list-style-type: none"> • Measure discharge flow rate of propulsion pump with flow meter. • If discharge flow rate is not within specified range, repair propulsion pump or replace it if necessary.
	Discharge flow rate is insufficient due to wear of propulsion pump drive shaft splines.	Replace propulsion pump.
	Propulsion circuit pressure is not held in propulsion pump case.	If pressure in propulsion pump case is not within allowable range, repair propulsion pump or replace it if necessary.

3-2-4. Machine speed does not change

Check point	Cause	Check/Action
1. Speed Change Solenoid Valve	Vehicle speed does not change because spool of speed change solenoid valve does not change.	Repair speed change solenoid valve or replace it if necessary.
2. Propulsion Motor Swash-Plate Stroke Cylinder	Propulsion motor swash-plate stroke cylinder is faulty.	Repair propulsion motor or replace it if necessary.

3-2-5. Machine does not stop completely with F-R lever in neutral

Check point	Cause	Check/Action
1. F-R lever Linkage	F-R lever linkage is faulty.	Check and adjust F-R lever linkage or replace it if necessary.
2. Servo Control Valve	Servo control valve neutral position adjustment failure.	Check and adjust servo control valve or replace it if necessary.
3. Propulsion Pump Servo Cylinder	Faulty propulsion pump servo cylinder or faulty pump swash plate setting.	Repair propulsion pump or replace it if necessary.

TROUBLESHOOTING

3-2-6. Propulsion system is overheating

Check point	Cause	Check/Action
1. Oil Level of Hydraulic Oil Tank	Oil level in hydraulic oil tank is low.	Fill tank until correct oil level is obtained.
2. Oil Cooler	Cooling efficiency is reduced due to clogged oil cooler fins.	Clean oil cooler fins.
3. Flushing Valve	Hydraulic oil in propulsion closed circuit is insufficiently cooled due to flushing valve shuttle spool sticking.	Repair flushing valve or replace it if necessary.
	Hydraulic oil in propulsion closed circuit is insufficiently cooled because flushing valve relief setting pressure is excessively high.	Check dust or damage in flushing relief valve and replace it if necessary.
	Hydraulic oil in propulsion closed circuit is insufficiently cooled due to flushing valve relief valve poppet sticking.	Clean flushing relief valve or replace it if necessary.
4. Propulsion Circuit Pressure	If circuit pressure setting is excessively low, relief valve opens, causing temperature of hydraulic oil in circuit to rise.	<ul style="list-style-type: none">• Measure propulsion circuit pressure.• If low, increase relief setting pressure.
	If load is excessively heavy, relief valve opens, causing temperature of hydraulic oil in circuit to rise.	<ul style="list-style-type: none">• Measure propulsion circuit pressure.• If high, decrease propulsion load.
5. Suction Filter for Charge Pump	Load of charge pump increases due to clogged filter, causing temperature of hydraulic oil in circuit to rise.	Clean suction filter or replace it if necessary.
6. Hydraulic Oil Filter	Charge circuit pressure increases due to clogged filter.	Clean hydraulic oil filter or replace it if necessary.

3-2-7. Abnormal noise from propulsion system

Check point	Cause	Check/Action
1. Axle Bearings	Axle bearings supporting front and rear drums are damaged.	Replace axle bearings.
2. Hydraulic Hose Clamp	Vibrator sound of hydraulic hose is generated because clamp securing hydraulic hose is loose.	Tighten bolts of loose hydraulic hose clamp to specified torque.
3. Suction Filter for Charge Pump	Cavitation is occurring in charge pump due to clogged filter.	Clean suction filter or replace it if necessary.
4. Charge Circuit Pressure	If charge pressure is low, brake cannot be released completely, which causes brake drag.	<ul style="list-style-type: none">• Measure charge pressure.• If low, check and adjust charge relief valve or replace it if necessary.
5. Propulsion Motor	Internal bearing of propulsion motor is damaged.	Repair propulsion motor or replace it if necessary.

3-3. Steering System

If a problem occurs in steering systems such as steering pump and orbitrol, determine cause and carry out action as required, according to following general troubleshooting items.

(NOTICE)

- When checking whether or not the pressure is correct, refer to the pressure standard value for each hydraulic circuit.

3-3-1. Steering wheel is hard to turn

Check point	Cause	Check/Action
1. Oil Level of Hydraulic Oil Tank	Oil level in hydraulic oil tank is low.	Fill tank until correct oil level is obtained.
2. Orbitrol	Relief valve is open or setting pressure is low.	<ul style="list-style-type: none"> • Measure steering circuit pressure. • If low, check and clean relief valve or replace it if necessary.
	Flow to steering cylinder circuit is insufficient due to leakage from check valve.	Check and clean check valve or replace it if necessary.
	Spool and sleeve of orbitrol are contaminated or clearance is incorrect.	Check and clean orbitrol or replace it if necessary.
3. Steering Circuit Pressure	Pressure in return circuit from orbitrol increases due to clogged charging hydraulic oil filter.	Clean hydraulic oil filter or replace it if necessary.
4. Steering Cylinder	Cylinder thrust decreases due to internal leakage of steering cylinder.	Repair steering cylinder or replace it if necessary.
5. Suction Filter for Charge Pump	Charge pump discharge rate decreases due to clogged filter.	Clean suction filter or replace it if necessary.
6. Charge Pump	Discharging pressure is insufficient due to efficiency degradation of charge pump.	<ul style="list-style-type: none"> • Measure steering circuit pressure. • If low, replace charge pump.
7. Steering Column	Column shaft and orbitrol shaft center are misaligned.	Align column shaft with orbitrol shaft center or replace it if necessary.
	Column shaft bearing is worn or damaged.	Repair column shaft or replace it if necessary.

3-3-2. Steering response is slow

Check point	Cause	Check/Action
1. Oil Level of Hydraulic Oil Tank	Oil level in hydraulic oil tank is low.	Fill tank until correct oil level is obtained.
2. Orbitrol	Oil is bypassing because relief valve is open.	<ul style="list-style-type: none"> • Measure steering circuit pressure. • If low, check and adjust relief valve or replace it if necessary.
3. Steering Cylinder	Internal leakage of steering cylinder.	Repair steering cylinder or replace it if necessary.
4. Suction Filter for Charge Pump	Charge pump discharge rate decreases due to clogged filter.	Clean suction filter or replace it if necessary.
5. Charge Pump	Discharging pressure is insufficient due to efficiency degradation of charge pump.	<ul style="list-style-type: none"> • Measure steering circuit pressure. • If low, replace charge pump.

TROUBLESHOOTING

3-3-3. Steering wheel backlash or play is large

Check point	Cause	Check/Action
1. Steering Column	Spline of column shaft or orbitrol is worn.	Replace column shaft or orbitrol.
	Column shaft bearings are worn.	Replace column shaft bearings.
2. Steering Wheel	Serration (spline) of wheel or column shaft is worn.	Replace wheel or column shaft.
3. Roller Chain	Roller chain is faulty.	Replace roller chain.

3-3-4. Steering system is overheating

Check point	Cause	Check/Action
1. Oil Level of Hydraulic Oil Tank	Oil level in hydraulic oil tank is low.	Fill tank until correct oil level is obtained.
2. Oil Cooler	Cooling efficiency is reduced due to clogged oil cooler fins.	Clean oil cooler fins.
3. Steering Circuit Pressure	If circuit pressure setting is excessively low, relief valve is open, causing temperature of hydraulic oil in circuit to rise.	<ul style="list-style-type: none">• Measure steering circuit pressure.• If low, replace relief valve.
	If load is excessively heavy, relief valve is open, causing temperature of hydraulic oil in circuit to rise.	<ul style="list-style-type: none">• Measure steering circuit pressure.• If high, decrease steering load.
4. Suction Filter for Charge Pump	Load of charge pump increases due to clogged filter, causing temperature of hydraulic oil in circuit to rise.	Clean suction filter or replace it if necessary.

3-3-5. Abnormal noise from steering system

Check point	Cause	Check/Action
1. Oil Level of Hydraulic Oil Tank	Pump suction pressure is high because oil level of hydraulic oil tank is low, causing cavitation in steering circuit system.	Fill tank until correct oil level is obtained.
2. Air in Steering Circuit	Cavitation is caused by air in circuit.	Bleed circuit.
3. Hydraulic Hose Clamp	Vibrator sound of hydraulic hose is generated because clamp securing hydraulic hose is loose.	Tighten bolts of loose hydraulic hose clamp to specified torque.
4. Suction Filter for Charge Pump	Cavitation is occurring in charge pump due to clogged filter.	Clean suction filter or replace it if necessary.

SAKAI HEAVY INDUSTRIES, LTD.

Head office: Seiwa Bldg., 4-8, Shibadaimon 1-chome,
Minato-ku, Tokyo, Japan

Telephone: +81-3-3434-3401

Global Service Division: 2500 Takayanagi, Kuki-shi, Saitama, Japan

Telephone: +81-480-52-1111

Copyright © 2011 SAKAI HEAVY INDUSTRIES, LTD. All Rights Reserved.

Printed in Japan 2012.01.50.M.B

0634-99234-0-31172-E