

⚠ Read this handbook thoroughly and understand the whole information contained before trying to operate, inspect and service your machine!

M  
O  
D  
E  
L  
  
S  
V  
4  
0  
0  
-  
2  
  
S  
E  
R  
I  
E  
S

**OPERATING &  
MAINTENANCE  
INSTRUCTIONS**

**SAKAI HEAVY INDUSTRIES, LTD.**

**VIBRATING  
ROLLER**

MODEL  
**SV400-2 Series**  
**SV400D-2**  
**SV400T-2**    **SV400TF-2**  
**SV400TB-2** **SV400FB-2**

From 3SV24 - 40101

## PREFACE

This operator's manual serves as a guide for the use of your Sakai SV400-2 Series Vibrating Roller for those who are new to the machine, and also for the people who have experience in using the Machine and want to refresh their knowledge for the machine.

Read this manual thoroughly and try to fully understand the information before operating your machine. Keep this handbook at hand whenever you do your work.

The main subjects of this manual are:

(1) Basic precautions for safety, (2) Operation, (3) Daily maintenance and (4) Specifications. For operation and maintenance of the engine, refer to the Engine Instruction Manual furnished separately. Descriptions in this manual can differ from the machine instructions of your machine due to the results of the investigation and improvement in its design. If you have any inquiry regarding your Machine or this manual, contact our distributors.

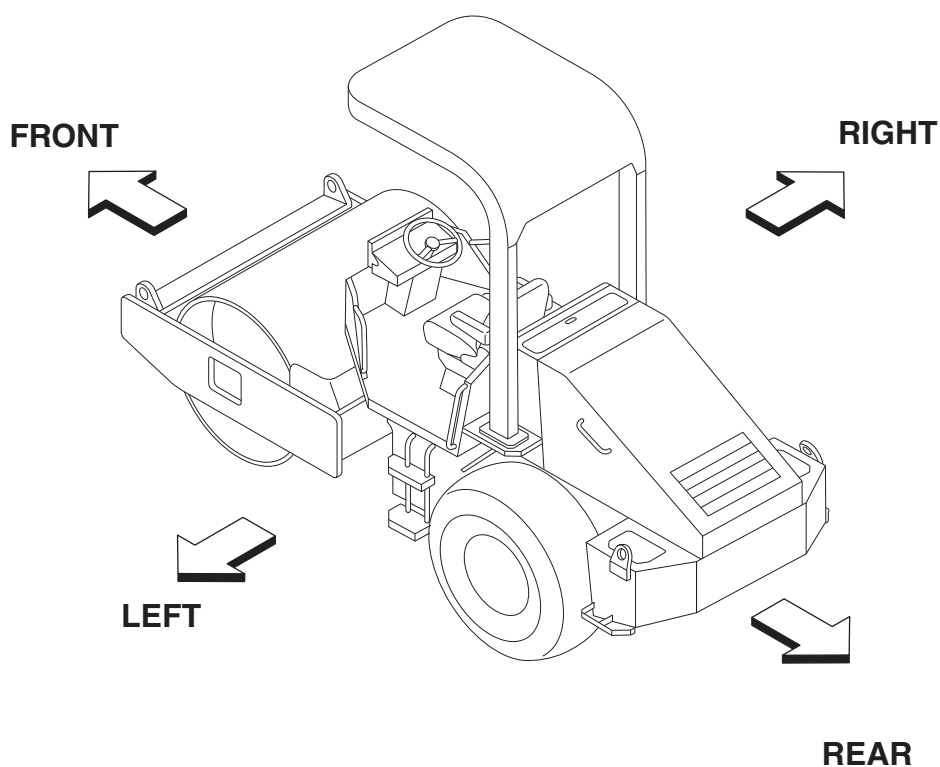

**CONTENTS**

PREFACE

MACHINE AND ENGINE IDENTIFICATION NUMBERS ..... 1

SAFETY NOTICES..... 2

1. BASIC SAFETY PRECAUTIONS ..... 4

1.1 General Precautions ..... 4

1.2 Preparation for Safe Operation ..... 6

1.3 Before Starting the Engine..... 7

1.4 After Starting the Engine..... 8

1.5 During Operation ..... 8

1.6 Loading and Unloading.....10

1.7 Transportation.....11

1.8 Handling the Battery .....11

1.9 Towing.....12

1.10 Before Servicing .....13

1.11 During Servicing .....14

1.12 Safety Decals.....16

2. OPERATION.....18

2.1 Instruments and Controls.....18

2.1.1 Operator’s station .....18

2.1.2 Gauges, indicator lamps and warning lamps .....19

2.1.3 Switches.....21

2.1.4 Operating levers / pedals .....23

2.1.5 Unloader valve .....25

2.1.6 Fuse box.....25

2.2 Handling and Adjustments .....26

2.2.1 Seat adjustment .....26

2.2.2 Scraper adjustment and replacement .....27

2.2.3 Disengaging the brake when towing .....28

2.3 Operation .....29

2.3.1 Before-starting inspection .....29

2.3.2 Starting the engine .....30

2.3.3 After starting the engine .....31

2.3.4 Traveling .....32

2.3.5 Stopping / Parking .....33

2.3.6 Stopping the engine .....34

2.3.7 Check after stopping the engine .....34

2.4 Vibratory Operation.....35

2.5	Precautions for Work.....	36
2.5.1	Compaction operation.....	36
2.5.2	When going downhill.....	36
2.5.3	On a slope.....	36
2.6	Applicable Jobs.....	37
2.7	After Operation.....	38
2.8	Loading and Unloading.....	39
2.8.1	Use of a trailer equipped with a winch.....	39
2.8.2	Self-propelling.....	40
2.9	After Loading the Machine.....	41
2.10	Transportation.....	41
2.11	Operation in Cold Weather.....	41
2.11.1	Fuel oil and grease.....	41
2.11.2	Coolant.....	41
2.11.3	Battery.....	42
2.12	When the Cold Season is Over.....	43
2.13	For a Long Storage Period.....	43
2.14	During the Storage Period.....	43
2.15	When the Battery Has Discharged.....	44
2.15.1	Connection and disconnection of booster cables.....	44
3.	PERIODIC MAINTENANCE.....	46
3.1	Precautions.....	46
3.1.1	Lifting the machine on a hoist.....	48
3.2	Walk-around Checking.....	49
3.3	Periodic Maintenance Points.....	50
3.4	Maintenance Procedure.....	52
(1)	Every 10 hours or daily.....	52
(2)	Every 50 hours.....	53
(3)	Every 250 hours.....	55
(4)	Every 500 hours.....	57
(5)	Every 1000 hours.....	60
(6)	As required.....	62
3.5	Fluid and Lubricant Capacities.....	64
3.6	Electric Wiring Diagram.....	66
3.7	Fuse Box.....	67
3.8	Battery.....	67
4.	SPECIFICATIONS.....	68



## MACHINE AND ENGINE IDENTIFICATION NUMBERS

When ordering parts or making inquiries about your machine, the following information is requested:

### (1) Machine model

Indicated on the nameplate of the right side of the operator's seat.

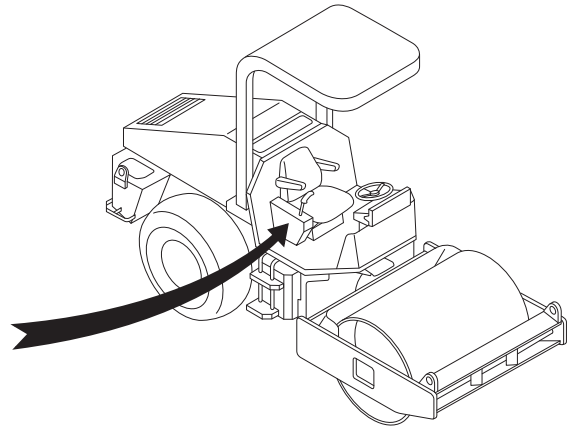
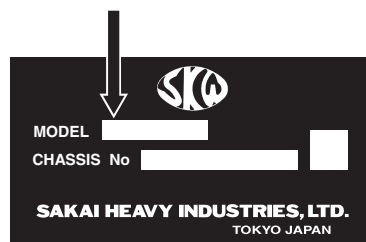

### (2) Machine serial number

SV400-2 ⇨ 3SV24-○○○○○

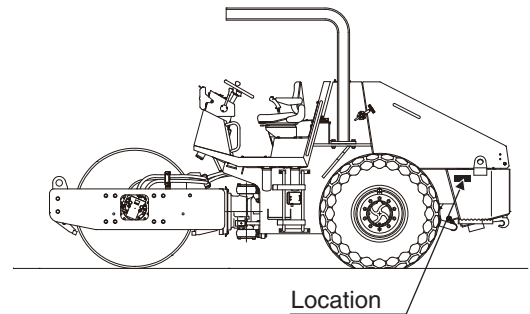

### (3) Engine serial number

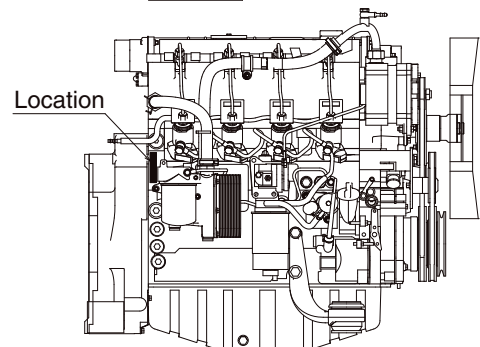
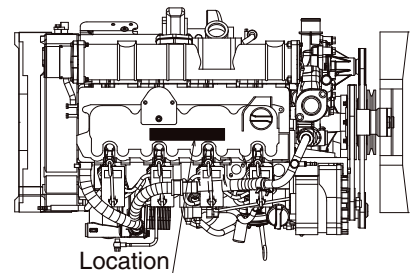







## **SAFETY NOTICES**

For the safe use of your machine, correct handling and periodic maintenance are of utmost importance. Thoroughly read the safety precautions described in this manual. Do not attempt to operate and maintain your machine until you gain a full understanding of these safety statements.

This manual covers the proper and safe method of driving and handling of this machine for its intended use. When this machine is used a manner, other than that covered in this manual, you must assume responsibility for your own personal safety.

In this manual and on the machine, you will find safety notices. Each safety notice starts with a signal word as shown below:

- |  |   |
|--|---|
|  <b>DANGER</b>    | <b>Denotes that there is an extreme hazard. If you fail to take proper precautions, it is highly likely that you could be killed or seriously injured (The color of the symbol  is red).</b> |
|  <b>WARNING</b> | <b>Denotes that there is a hazard. If you fail to take proper precautions, you could be killed or seriously injured (Symbol  is orange).</b>   |
|  <b>CAUTION</b> | <b>Calls attention to safety practices. If you fail to take proper precautions, you could be injured or cause damage to the machine (Symbol  is yellow).</b>                                  |

It is almost impossible for the safety notices in this manual and or the machine to cover all the potential dangers. Keep alert to possible dangers not mentioned in this manual and on the decals.

 **WARNING**

**Do not operate your machine before you read its operator's manual thoroughly.**

**Incorrect operation can kill or cause injury.**

**It is your responsibility to operate the machine safely.**

- ☆ Non-approved modifications can pose safety-related problems. Before making any modifications, consult your distributor. For an injury or damage to the machine caused by non-approved modifications, Sakai accepts no responsibility.
- ☆ Basic precautions for safe operation of your machine are discussed beginning on page 4.
- ☆ To operate and work with your machine, you must be qualified.

## 1. BASIC SAFETY PRECAUTIONS

### 1. BASIC SAFETY PRECAUTIONS

#### 1.1 General Precautions

■ **Read the operator's manual thoroughly.**

- Understand the functions of the controls and gauges. Familiarize yourself with their location and how to operate them. Understand the meaning of all the symbols.



■ **Obey the worksite rules.**

- Follow the worksite rules such as posted warnings, precautions, and hazards. Follow work procedures established for your job site.

■ **Wear protective clothing to suit the work.**

- Personal protective equipment such as, but not limited to, hearing protection, safety shoes and hard hat.
- Do not wear loose clothing and accessories that could get caught in the controls or protruded portions of the machine. Do not wear oily clothing.
- According to the type of jobs, wear safety goggles or mask.



■ **Know the work area in advance.**

- Know the terrain, geology and conditions of the road surface at the worksite. Beware of weak spots in the base that could collapse, causing the machine to tip over.

■ **Provide against an accident.**

- Decide in advance the means of communication in an emergency. Know the location and use of a fire extinguisher and first-aid kit.

■ **Know the capability of the machine.**

- Thoroughly understand the performance of your machine and correctly operate the machine to meet the requirements of the job site. Operating the machine beyond its capabilities may lead to an accident. Use your machine within its capability.

**⚠ WARNING: Negligence of these instructions can lead to accidents.**

**1. BASIC SAFETY PRECAUTIONS**

**■ Do not use a machine which has not been serviced correctly at regular intervals.**

- Before working, perform necessary inspections. Start operation only after making certain the machine is in good operating condition. If found to be abnormal, report to the responsible person and have the fault corrected. Operate the machine after making sure that it is safe to operate.

**■ Do not allow anyone to enter the work area except for authorized personnel.**

- Always conduct the work paying attention to the workers around the machine.



**■ Be careful of hot parts.**

- After your machine has operated for some time, the coolant, engine oil and hydraulic fluid will become hot and the pressure will build up. If, in this state, you try to remove the filler caps, drain the oil or replace the filters, you can get burned. Perform this work in accordance with the correct procedures with the machine cooled down.
- To remove the radiator cap, shut off the engine, allow the coolant to cool down, then using a rag to cover the radiator cap, slowly loosen the cap and relieve the pressure. (For the radiator cap with a lever, lift the lever to release the trapped pressure.)
- When removing the filler cap on the hydraulic tank, release the trapped pressure by turning it slowly to prevent the oil from gushing out.
- Do not touch the muffler while the engine is running or immediately after it has been shut down. You can get burned.



**■ Be careful with fire.**

- The fuel, oil, and anti-freeze will catch fire if open flames or ignition sources they are exposed to, or come in contact with. Fuel is especially flammable and explosive.
- Do not smoke or use a match or cigarette lighter close to inflammables (combustibles).
- When refueling, stop the engine and do not smoke.
- The filler caps of the fuel and oil tanks must be kept tight.



## **1. BASIC SAFETY PRECAUTIONS**

### **■ Mount on or dismount from your machine after it has come to a complete stop.**

- For getting on and off, face the machine and use the handrail and step.
- Do not jump on or off a machine, particularly when it is moving.

### **■ To handle the hydraulic fluid.**

- Wear safety goggles to protect your eyes from contact with hydraulic fluid. It can irritate your eyes.  
If the fluid contacts your eyes, flush with clean water for 15 minutes and get medical aid.
- The fluid can also irritate your skin. When handling it, wear rubber gloves to avoid contact with it. In case of skin contact, wash with soap and water.
- Be careful not to swallow the fluid. It can cause diarrhea and emesis.  
If swallowed, do not try to vomit. Get medical help immediately.



## **1.2 Preparation for Safe Operation**

### **■ Clean the step, operator's station and floor board.**

- Do not place parts, tools or unnecessary articles on the step, operator's station and floor board.
- Keep the step, floor board, controls and handholds free from muds, oil, ice or water, as they can cause slippage. Repair them if found to be damaged. Tighten loose bolts.
- Keep your boot soles free of oil or muds. They can slip, leading to an accident.

### **■ Inspect your machine before operation**

- Check your machine for damage such as cracks and deformation. If found to be abnormal, operate the machine after taking a proper measure to secure safety.
- Check the level of fluids (fuel, engine oil, coolant, anti-freeze and hydraulic oil). Add as necessary.
- Check the area where the machine has parked for signs of leakage of oil, fuel and water. If any leakage is noticeable, determine the cause and make corrections immediately.

**⚠ WARNING: Negligence of these instructions can lead to accidents.**

## 1. BASIC SAFETY PRECAUTIONS

### ■ Know the stopping distance.

- When traveling on a road, bear in mind the stopping distance. Avoid excessive speed, and abrupt starting and stopping, and moving in a zigzag direction.

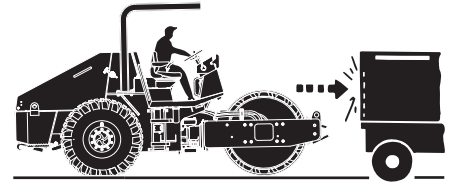

## 1.3 Before Starting the Engine

### ■ Adjust the operator's seat to your most effective operating position.

- Sit on the operator's seat. Adjust the seat so that your back will make contact with the seat back when the brake pedal is depressed to the full extent. Check to be sure that the brake pedal can be fully depressed without difficulty when you twist your body for reverse run.

### ■ Check that the horn, lamps and gauges work correctly.

### ■ Before starting, make certain that each lever is in the neutral position and the parking brake is applied.

### ■ When starting, sound the horn.

- Before starting the engine. Make sure there is no one in the immediate vicinity and there are no obstructions around the machine.



### ■ Pay attention to ventilation.

- Exhaust fumes are dangerous if breathed in. When starting the engine in an enclosed area, provide good ventilation with windows and doors opened.



### ■ Do not stand close to the exhaust gas pipe opening.

- Exhaust fumes are noxious if breathed in.

## **1. BASIC SAFETY PRECAUTIONS**

### **1.4 After Starting the Engine**

#### **■ Secure safety around the machine.**

- Ensure that the area around the machine is clear of personnel and obstructions. Pay particular attention to dead spaces. Before starting, sound the horn.



#### **■ Warm up the Engine**

- Do not put your machine into motion immediately after the engine has started, let it idle for several minutes until it is at operating temperature.
- Check the area where the machine has parked for signs of leakage or oil, fuel and water. If any leakage is noticeable, determine the cause and make corrections immediately.

#### **■ Have a trial run.**

- Make a test run in a safe place to check that there are no abnormal signs. If found to be abnormal, rectify the fault before traveling again.
- Listen for unusual sounds, and check for abnormal temperature rise. If abnormal, park the machine in a safe location and find the source of trouble before operating.

### **1.5 During Operation**

#### **■ No other person but the operator**

- This machine is a one-man roller. Do not allow anyone to get on. Only the operator is allowed on this machine while it is running or in operation. Radios are not permitted.

#### **■ Before mounting, be sure areas around the machine are safe.**

- Before getting on the machine, make certain that there are no obstacles around the machine and no workers under it. If some workers are present or close to the machine, tell them that the machine is about to move, warning them to stay away from it.

#### **■ Seatbelt**

- Be sure to wear the seatbelt during operation.



**⚠ WARNING:** Negligence of these instructions can lead to accidents.

## 1. BASIC SAFETY PRECAUTIONS

### ■ Do not try to get on or off a moving machine.

- Get on or off the machine after making sure it has come to a complete stop and the parking brake is applied.

### ■ To go uphill or downhill, run at low speeds. Do not attempt to shift speeds while traveling on a grade.

- Shifting speeds on a slope can cause unexpected running down the slope.
- Going down hill at speeds other than low range can cause the machine to run down violently.

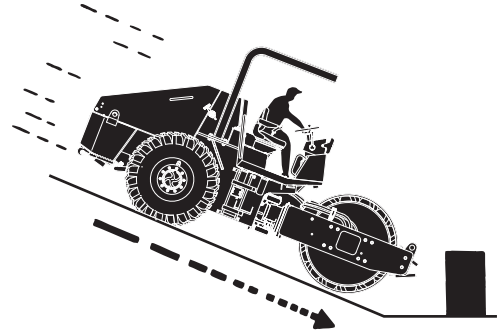

### ■ Refrain from inattentive driving.

- Inattentive driving or driving relying on guess work can cause an accident. Use extreme care for workers present in the path of the roller or around it. In case of danger, stop and sound the horn, and proceed when the area is clear of personnel or obstructions.

### ■ When changing the direction of travel, secure the safety on the path in the travel direction.

### ■ Keep everyone away from the pinch points.

- When making turns, do not allow anyone to come close to the pinch point.

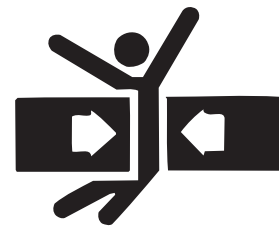

### ■ At night, carefully drive the machine.

- Nighttime driving tends to impair the sense of distance. Carefully drive the machine at a speed suited to illumination. Keep the headlamps and flood lamps on. If necessary, provide extra lighting in the work area.

### ■ Repair as soon as possible if found to be defective.

- If the machine is found to be faulty, stop the machine and repair it. Do not operate the machine until the problem is corrected. When any warning lamp indicates faulty operation, inspect the machine after moving it to the nearest safe location.

## 1. BASIC SAFETY PRECAUTIONS

- **Do not operate the machine except from the operator's seat. Do not drive in a standing posture.**
- **While making turns, do not run at a high speed and do not turn the steering wheel abruptly and sharply. High speed turns, especially on soft or uneven ground, could result in a rollover.**
- **For the traveling on structures such as a bridge, make certain that they can support your machine. Before traveling on the structure, you must know the load capacity of the structure and the load weight of the machine you are operating to ensure safe travel across the structure.**
- **Do not make turns on a slope and do not travel across sidehill. If necessary to do so, go down straight along the slope to the flat ground, move sideways and go up straight to the destination.**

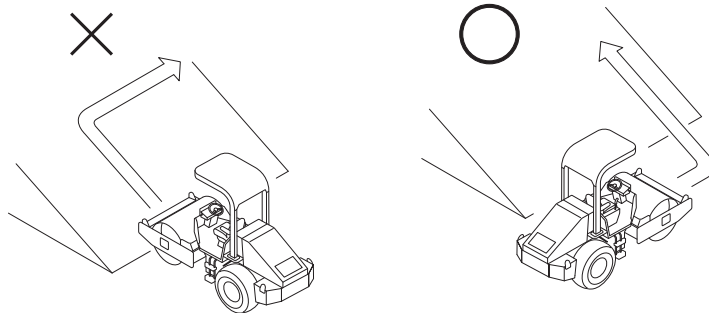

### ■ When parking.

- Select level and hard ground. If necessary to park on a slope, block the front of the drums on the downside of the slope.
- When required to park on a public road, provide necessary delineators such as flags, barriers and illumination. However, be sure they do not obstruct traffic.
- When getting off the machine, stop the engine and remove the key from the ignition switch.

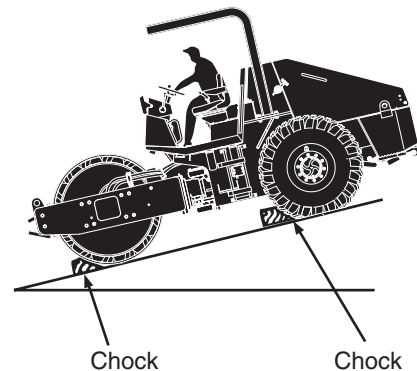

## 1.6 Loading and Unloading

- Loading and unloading can be very dangerous. Use extreme care.
- Select level and hard ground leaving a sufficient distance from the shoulder.
- Use sturdy ramps with proper width, length and thickness which allow safe loading and unloading. If they deflect considerably under load, apply wooden blocks to reinforce the ramps.

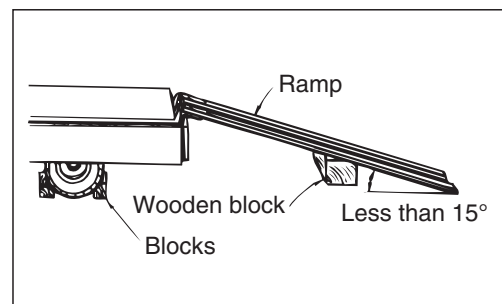

**⚠ WARNING: Negligence of these instructions can lead to accidents.**

## 1. BASIC SAFETY PRECAUTIONS

- To prevent your machine from crosswise slippage, keep the ramps free from oil, mud, debris, etc. The drum must also be free from extraneous matter that can cause slippage.
- Do not steer your machine on the ramps. If the machine is facing in the wrong direction, allow it to dismount from the ramps, correct the direction and try again.
- Do not use kinked, twisted or damaged cables for crane or winch operation. Use cables with ample strength.
- When loading is complete, secure the machine with wooden blocks placed under the drums and chains fastened to the machine.

### 1.7 Transportation

- Follow required regulations.
- Select a transporting route according to the overall width, overall height and gross weight of the trailer with the roller loaded.
- Know the maximum height clearance of the machine loaded on the transport trailer before hauling under bridges and other structures.

### 1.8 Handling the Battery

■ When handling the battery:

- Battery electrolyte contains sulphuric acid. It will destroy clothing and skin. If it touches your clothing or skin, flush with large quantities of water.
- In case of eye contact, flush with clean water and seek medical help.
- If swallowed, drink large amount of water, milk, beaten egg or vegetable oil, and get medical help.
- Wear safety goggles when handling the battery. Wear safety goggles, full face shield, rubber gloves and rubber apron when adding fluids to the battery.
- The battery generates flammable gases that can cause an explosion. Do not smoke close to the battery. Keep the battery away from flames, sparks and ignition sources.



**⚠ WARNING**

**Battery posts, terminals, and related accessories contain lead and lead compounds, chemicals known to the State of California to cause cancer and reproductive harm. Wash hand after handling.**

## 1. BASIC SAFETY PRECAUTIONS

- Inspect or handle the battery with the engine shut down and the starter key in the OFF position.
- Keep metallic items such as tools away from the battery terminals.
- Loose terminals can cause sparks leading to an explosion. Secure the terminals tightly.

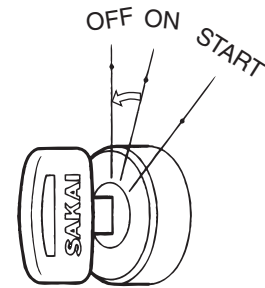

### ■ Jump-starting the engine.

- Wear safety goggles when jump-starting the machine.
- When starting from another machine, do not allow the two machines to make contact with each other.
- When connecting the battery cables, start with the positive terminal. For disconnection, start with the negative one.
- Do not allow a tool to bridge and make a connection between the positive terminal and machine body. This can generate dangerous sparks.
- Do not connect the booster cable to wrong terminal. NEVER connect the positive terminal to the negative.
- Final connection to the engine block of the disabled machine can cause sparks. The connecting point should be as far as possible from the battery.

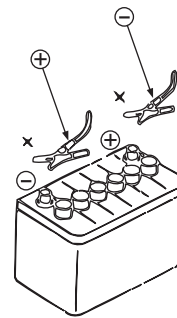

## 1.9 Towing

- To tow the machine, use cables with ample strength.
- Do not perform towing on a slope.
- Do not use twisted, kinked or damaged cables when towing.
- Keep everyone away from the space between the machine and the towing vehicle when connecting the two.
- Align the connection points of the disabled machine and the towing vehicle in a straight line when connecting the machines.

**⚠ WARNING:** Negligence of these instructions can lead to accidents.

**1. BASIC SAFETY PRECAUTIONS**

**1.10 Before Servicing**

**■ Attach warning tags when servicing the machine.**

- Serious accidents can occur if the machine is unexpectedly started or controls carelessly touched by an unauthorized person.
- Attach a warning tag at a clearly visible location in the operator's station and insure the key has been removed from the ignition switch.



**■ Use proper tools.**

- It is very dangerous to use damaged or deteriorated tools or to use tools for purposes other than intended. Use correct tools for their intended use only.



**■ Change safety-related parts at regular intervals.**

- Replace fuel hose and high pressure hydraulic hoses regularly to prevent fire. Replace high pressure hoses of the power steering system every two years.
  - ☆ Change these parts at regular intervals even if found to be normal. They deteriorate over time.
  - ☆ Change any hose found to be abnormal even if it is before its recommended service interval.

**■ Inspect or service your machine with the engine stopped.**

- If required to keep the engine running in such as when flushing the radiator, perform the work with two persons. One person should sit on the operator's seat ready to shut down the engine if necessary. He must take care not to touch any of controls carelessly. Maintenance personnel must exercise extreme caution not to make contact with moving parts.

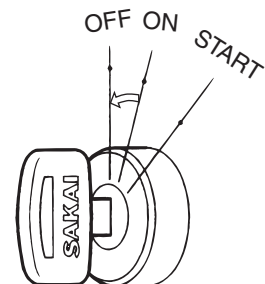

## **1. BASIC SAFETY PRECAUTIONS**

### **■ Supplying fuel and oils**

- Spilled fuel or oil will be slippery. Wipe up immediately. Keep the filler caps tight. Do not use fuel as a flushing oil. Handle fuel and oil in a well ventilated area.

### **■ Check the coolant level in the radiator.**

- To check the coolant level, shut down the engine and allow the engine and radiator to cool down before removing the radiator cap. Remove the cap by covering it with a rag before removing to prevent any fluid that could spray under pressure from causing a burn.

### **■ Illumination**

- For inspecting the level of the fuel, oil, coolant and battery electrolyte, use burn-proof illuminations. Failure to use this type of illumination can result in an explosion.



## **1.11 During Servicing**

### **■ Keep unauthorized persons away**

- During service, do not allow persons not concerned to enter the work area, particularly when grinding or welding operation is performed or heavy hammers are being used.



### **■ Keep your machine clean**

- Spilled oil, grease or scattered debris are dangerous. Always keep your machine clean. Moisture that penetrates into the electrical system can cause malfunctions. Do not use water to clean sensors, connectors and the operator's station.

### **■ When repairing the electrical system**

- For repairing the electrical system or for conducting welding, disconnect the negative cable from the battery to shut off the electricity.



### **■ Carefully handle high pressure hoses.**

- Do not try to bend or hit hoses against a hard object. Do not use hoses or pipes that are bent or damaged. They will burst.
- Replace damaged fuel hose and hydraulic hoses. An oil or hydraulic fluid spill can cause a fire.

**⚠ WARNING: Negligence of these instructions can lead to accidents.**

## 1. BASIC SAFETY PRECAUTIONS

### ■ Be careful of high pressure hydraulic fluid.

- Bear in mind that the working equipment hydraulic systems are under internal pressure. Do not perform adding, draining, inspection or servicing of the hydraulic systems until the internal pressure has been relieved. Hydraulic fluid leaking through a fine hole at high pressure can penetrate your skin and eyes. Inspect any leakage by holding a hard board close to suspected leaks and wear goggles. If skin or eyes are penetrated by high pressure oil, get medical help immediately.



### ■ Be careful of hot parts

- After the machine has been operated for some time, the coolant, engine oil and hydraulic fluid will become hot.
- Removing the radiator cap or draining the coolant or oil can burn you. Perform this work in accordance with correct procedures after the systems have cooled down.



### ■ Use care when inspecting or servicing fan or belts in motion

- Secure loose clothing and keep articles away that could get caught in moving parts.
- Do not let your body or tools make contact with the fan blades or belts. Moving fan belts and blades can cause serious injury or death.



### ■ Used oil disposal

- Do not throw used oil into a drain or waterway. Drain the oil from the machine into a proper container. Do not drain directly on the ground.
- Obey all local, state and federal environment regulations for the proper disposal of oil, fuel, coolant, battery electrolyte or any other fluids.

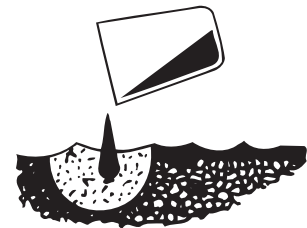

### ■ Exercise extreme care when replacing and repairing tires

- Disassembly, repair and reassembly of tires require special facility and knowledge. Have them repaired at work shop specialized in handling tires.
- Improperly fitted rim can separate if the tire is inflated. When inflating tires, do not work in front of the rim. Use correct inflation pressure.
- When dismounting a tire, chock other tires for safety.
- When welding job is carried out near the tires, use extreme care, as this can cause an explosion of the tires.





**1. BASIC SAFETY PRECAUTIONS**

**1.12 Safety Decals**

Keep all decals clean. If lost, replace with new one. There are decals other than those shown below: Treat them in the same manner as the one shown here.

① 3998-16504-0

<b>⚠ WARNING</b>
<p><b>1. When Handling the Machine:</b></p> <ul style="list-style-type: none"> <li>· Operate only while seated.</li> <li>· Use the handrails and steps when boarding and getting off.</li> <li>· Never carry passengers.</li> <li>· Never attempt to board or get off the machine while it is moving.</li> </ul> <p><b>2. Preparation for Safe Operation</b></p> <ul style="list-style-type: none"> <li>· Clean the steps, operator's station and floorboards.</li> <li>· Obey the worksite rules.</li> <li>· Sakai accepts no responsibility for any injury or damage to the machine caused by unapproved modification.</li> <li>· Do not use a machine which needs repair or maintenance.</li> <li>· Sound the horn immediately prior to starting the engine to warn people in the vicinity.</li> </ul> <p><b>3. Starting the Engine</b></p> <ul style="list-style-type: none"> <li>· Check that all operating levers are in the neutral position.</li> <li>· Idle the engine for about 5 minutes to warm it up prior to commencing work.</li> </ul> <p><b>4. Parking Precautions</b></p> <ul style="list-style-type: none"> <li>· When parking the machine, park it on level ground, set the parking switch and set the roller chocks.</li> <li>· Allow the engine to cool off by running it for about 5 minutes before stopping.</li> <li>· When getting off the machine, remove the key from the ignition switch.</li> </ul>
<small>3998-16504-0</small>

② 3998-16497-1

<b>⚠ WARNING</b>
<ul style="list-style-type: none"> <li>· Thoroughly read the operator's manual before using the machine.</li> <li>· Incorrect operation can cause severe injury or death.</li> <li>· It is your responsibility to operate the machine safely</li> </ul>
<small>3998-16497-1</small>

③ 3998-16500-0

<b>⚠ WARNING</b>
<ul style="list-style-type: none"> <li>· Avoid inhalation of exhaust gas.</li> <li>· Avoid contact with exhaust pipe while engine is running and after it has been stopped. Contact with hot exhaust pipe will cause burns.</li> </ul>
<small>3998-16500-0</small>

④ 3998-16489-0

<p><b>CALIFORNIA</b> Proposition 65 Warning</p> <p>Diesel engine and some of its constituents are known to the State of California to cause cancer, birth defects, and other reproductive harm.</p>
<small>3998-16489-0</small>

⑤ 3998-16499-0 (2 locations)

<b>⚠ WARNING</b>
<ul style="list-style-type: none"> <li>· Do not open the hood with the engine running.</li> <li>· Contact with hot parts will cause burns.</li> <li>· Contact with rotating parts will cause severe injury.</li> </ul>
<small>3998-16499-0</small>

⑥ 3998-16535-0

<b>⚠ DANGER</b>
<ul style="list-style-type: none"> <li>· Do not open the radiator cap when fluid is hot.</li> <li>· Radiator fluid is flammable. Avoid exposure to flame when radiator cap has been removed.</li> </ul>
<small>3998-16535-0</small>

⑦ 3998-16505-0

<b>⚠ DANGER</b>
<p><b>Roll Over Prevention</b></p> <ul style="list-style-type: none"> <li>· Do not work in the vicinity of overhanging banks, or on grades steep enough to cause the machine to slide or roll over.</li> <li>· Reduce speed prior to making turns.</li> <li>· Pay particular attention when operating on uneven surfaces, as the machine may become unstable.</li> </ul>
<small>3998-16505-0</small>

⑧ 3998-36002-0 (2 locations)



⑨ 3998-16536-0

<b>⚠ DANGER</b>
<ul style="list-style-type: none"> <li>· Avoid contact with the machine parts in the vicinity of the engine while engine is running and after it has been stopped. Contact with hot parts will cause burns.</li> </ul>
<small>3998-16536-0</small>

⑩ 3998-16501-0

<b>⚠ DANGER</b>
<p><b>Be Careful with Fire</b></p> <ul style="list-style-type: none"> <li>· When refueling, stop the engine and do not smoke.</li> <li>· The filter cap of the fuel tank must be kept tight.</li> </ul>
<small>3998-16501-0</small>

⑪ 3998-16507-1

<b>⚠ CAUTION</b>
<p><b>Lubricate all grease fittings daily prior to commencing work.</b></p>
<small>3998-16507-1</small>

⑫ 3998-16510-0

<b>⚠ CAUTION</b>
<p><b>Refill the specified quantity of oil in the vibrator case when changing oil.</b></p>
<small>3998-16510-0</small>

⑬ 3998-16468-1

<b>⚠ CAUTION</b>
<p><b>PREVENT THE LOCKING OF PARKING BRAKE</b> When the vehicle storage for the long term, release the parking brake and travel to vehicle for a little while, then put the parking brake on again. Do this operation once a month at least.</p>
<small>3998-16468-1</small>

⑭ 3998-16559-0

<p><b>DANGER EXPLOSIVE GASES</b> Cigarettes, flames or sparks could cause battery to explode. Always shield eyes and face from battery. Do not charge or use booster cables or adjust post connections without proper instruction and training.</p> <p><b>KEEP VENT CAPS TIGHT AND LEVEL</b></p> <p><b>POISON CAUSES SEVERE BURNS</b> Contains sulfuric acid. Avoid contact with skin, eyes or clothing. In event of accident flush with water and call a physician immediately.</p> <p><b>KEEP OUT OF REACH OF CHILDREN</b></p>
<small>3998-16559-0</small>

⑮ 3998-06139-0

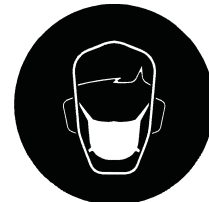

⑯ 2998-96001-1

<b>⚠ CAUTION</b>
<p><b>USE SPECIFIED FUEL ONLY</b></p> <ul style="list-style-type: none"> <li>· Use of other than the specified fuel may result in damage to the engine.</li> <li>· Please refer to the manual for details.</li> </ul>
<small>2998-96001-1</small>



**⚠ WARNING: Negligence of these instructions can lead to accidents.**

**1. BASIC SAFETY PRECAUTIONS**

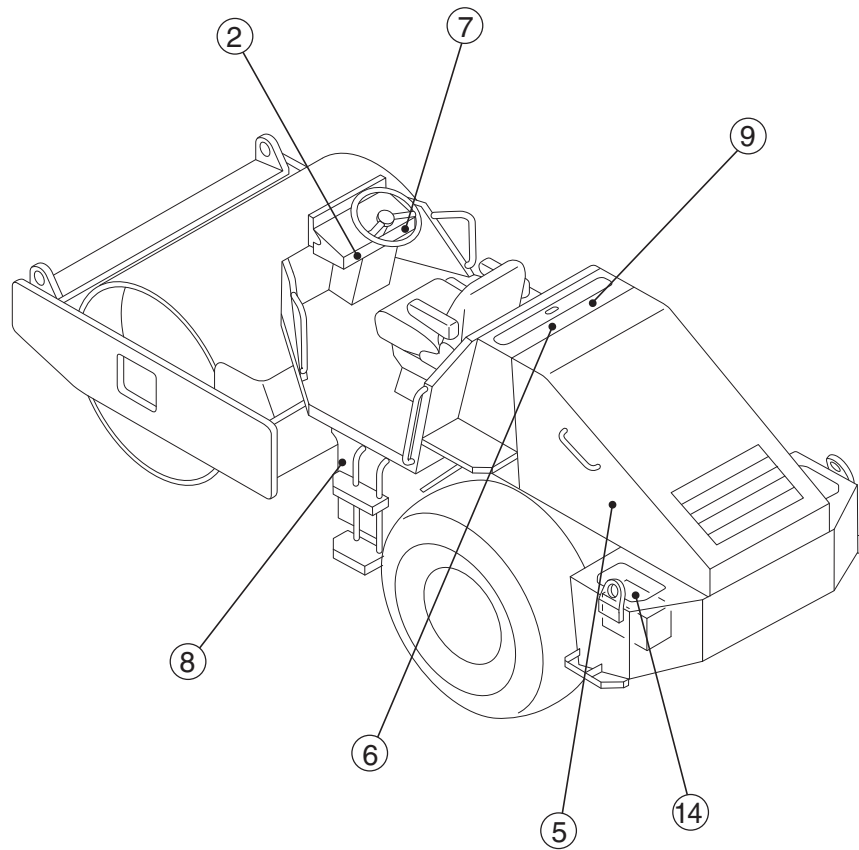
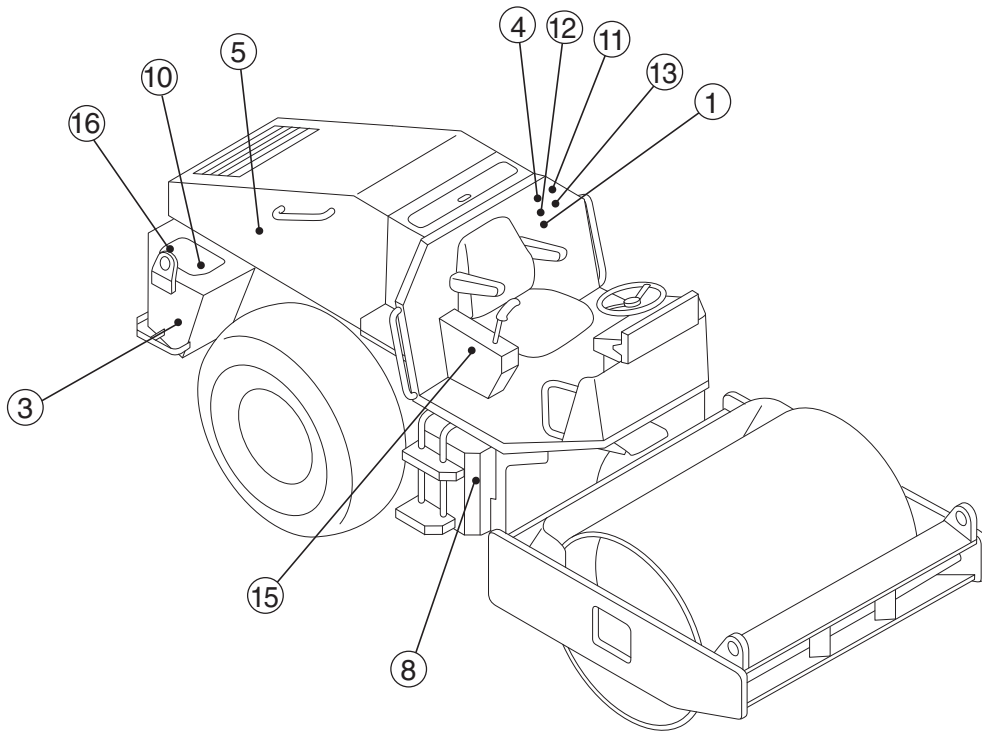

## 2. OPERATION

### 2.1 Instruments and Controls

#### 2.1.1 Operator's station

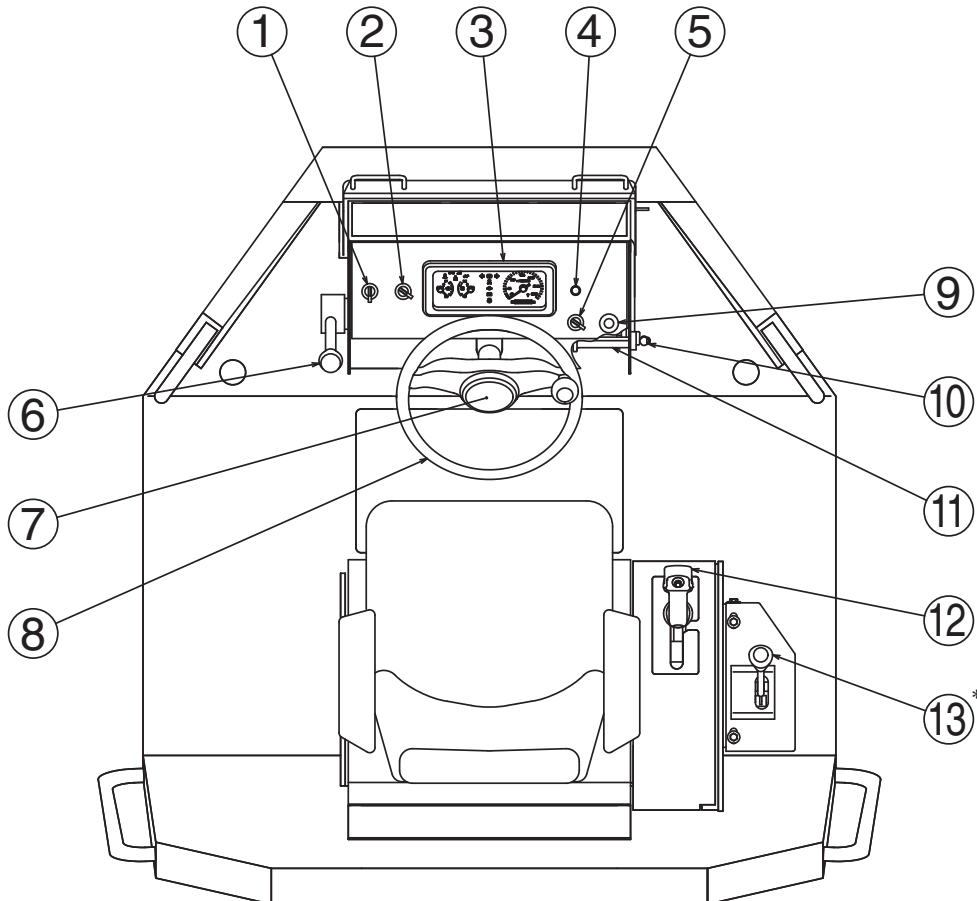

- |                             |   |
|-----------------------------|---|
| ① Vibration switch          | ⑧ Steering wheel  |
| ② Vibration selector switch | ⑨ Parking brake switch  |
| ③ Combination meter         | ⑩ Starter switch  |
| ④ Engine warning lamp       | ⑪ Brake pedal   |
| ⑤ Speed change switch       | ⑫ Forward-Neutral-Reverse (F-N-R) lever<br>(For vibration switch) |
| ⑥ Throttle lever            | ⑬ Leveling blade lift lever                                       |
| ⑦ Horn switch button        |   |

\* For SV400TB-2, SV400FB-2 only.

### 2.1.2 Gauges, indicator lamps and warning lamps

For safe execution of your job, fully understand the role and function of the systems involved.

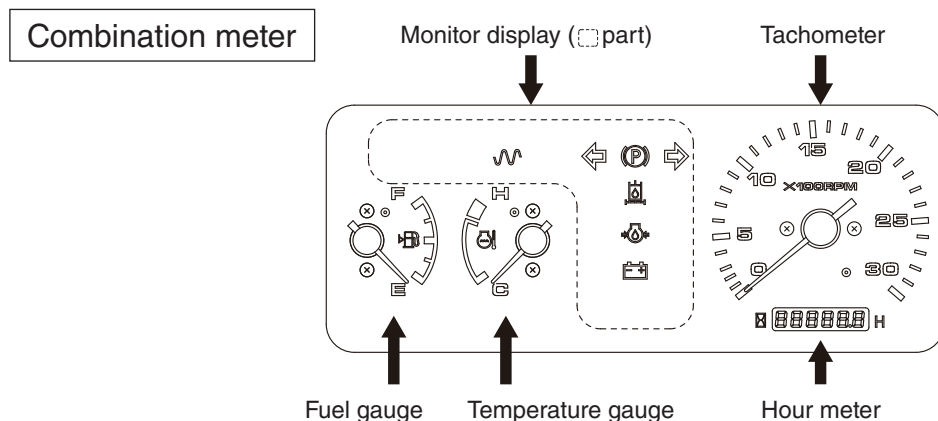

#### Tachometer / Hour meter

Indicates the engine RPM. The hour meter shows total operating hours. The service interval recommendation in this manual should be based upon the hour meter readings.

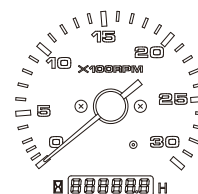

Tachometer / Hour meter

#### Temperature gauge

Indicates the coolant temperature. Zone close to symbol H indicates overheating. In case of overheating, run the engine at idling for about ten minutes before shutting it down. Then determine the cause.

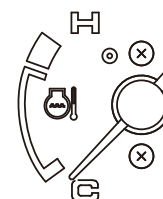

Temperature gauge

#### Fuel gauge

Indicates the fuel level in the tank.

E: The tank is empty.

F: The tank is full.

Replenish fuel appropriately before the fuel runs down.



Fuel gauge

#### ⚠ CAUTION

Be sure to use fuel recommended by SAKAI (refer to page 64).

## 2. OPERATION

### Monitor display

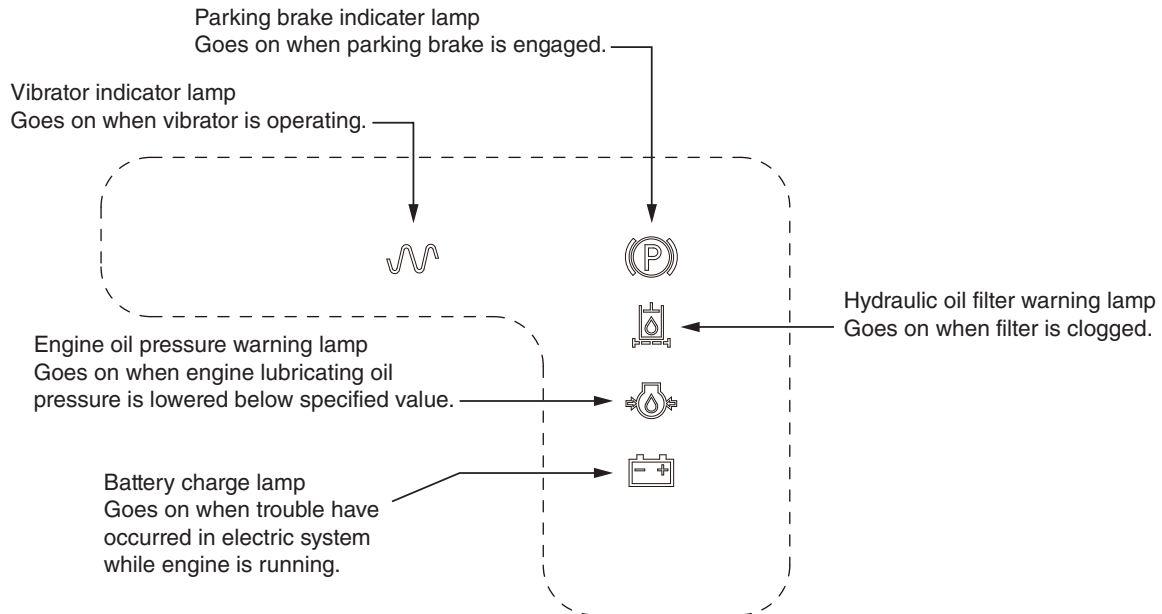

#### ★ Indicator lamps [ (P) ]

Light up when corresponding systems have been are operating.

#### ★ Warning lamps [ ]

Go on when the starter switch is turned to the ON position and go off when the engine has started. If any light up while the engine is running, this indicates a faulty condition. Stop the engine and trace the source of trouble.

#### ★ Checking for warning lamps and parking brake indicator lamp

They should turn on light when the starter switch is ON position. If not, there is some trouble. Check and repair the combination meter or wiring harnesses.

### ⚠ CAUTION

**Hydraulic oil filter warning lamp may go on when the engine rpm is increased before the engine has been warmed up enough. Keep the engine idling until the lamp goes off, before starting your work.**

### Engine warning Lamp

#### ★ Engine warning

When the engine stop lamp lights up, serious trouble has occurred in the engine. Stop the engine. Ask for appropriate inspection, maintenance, or repair.



### 2.1.3 Switches

#### Starter switch

Starts and stops the engine.

**OFF:** The key can be removed in this position. All the electric systems are switched off. To shut down the engine, move the key to this position.

**ON:** The charging circuit and lamp circuit are charged with electricity. Leave the key in this position after the engine has started.

**START:** The engine is cranked and gets started. The moment the engine has started, release the key. It will automatically return to the ON position.

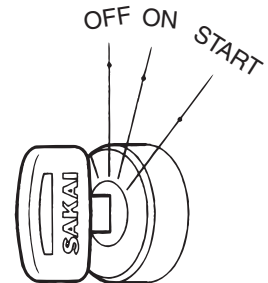

#### ⚠ CAUTION

**Set the Forward - Neutral - Reverse (F-N-R) lever in the neutral position and press down the parking brake seitch before starting the engine. Unless these conditions are met, the engine will not start.**

#### Parking brake switch

If switch (P) is pressed down, the parking brake will be applied with the indicator lamp (P) on the dashboard lit up.

When pressed again, the brake is released and the indicator lamp goes off.

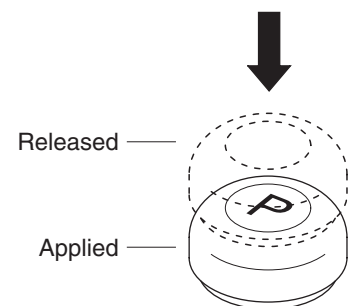

#### ⚠ WARNING

- To disengage the brake, be sure to press the button again instead of pulling it.
- Always press the button to apply the parking brake before dismounting from the machine.

#### ⚠ CAUTION

**Never pull the switch UP.**

#### ⚠ IMPORTANT

**In an emergency, apply brake by pressing the parking brake switch button.**

## 2. OPERATION

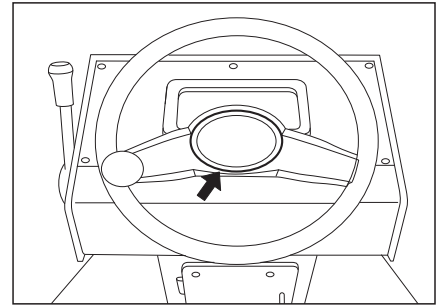

### Horn switch button

Pressing the button at the center of the steering wheel sounds the horn.



### Vibration switch

By means of vibration switch located on the panel, selection of vibration amplitude and On-Off is mode.

-  position: Turning the vibration switch clockwise causes the vibration to start with high amplitude.
-  position: Vibration is shut down.
-  position: Turning the vibration switch counter clockwise causes vibration to start with low amplitude.

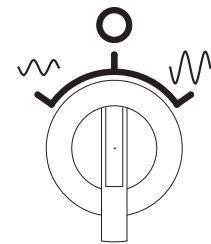



Vibration switch

**NOTE:** For vibratory rolling, run on full throttle.

### Vibration selector switch

Selection can be made between the vibration switch installed to the Forward-Neutral-Reverse (F-N-R) lever and the other one located on the panel.

-  position: Vibration can be turned ON or OFF with the switch located on the Forward-Neutral-Reverse (F-N-R) lever. Pressing this switch causes the vibration to start and pressing it again to stop.

This vibration switch on the lever should be used with the vibration switch on the panel placed at  or  position.

CONT position: Have this switch placed at this position when vibration is not to be actuated.

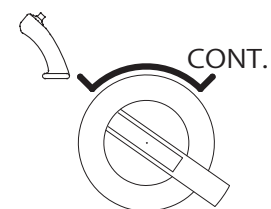

Vibration selector switch

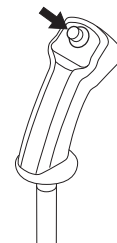

Vibration switch



**NOTE:** For vibratory rolling, run on full throttle.

**IMPORTANT**

- Do not operate the vibrator on a hard area such as cement concrete pavement surface or the ground covered by thick steel sheets.
- Keep the vibrator stopped when the machine is at rest.
- Shut off the vibrator immediately when the machine has been caught in the mud during vibratory operation.

## Speed change switch

Selects two vehicle speed ranges.

	 (Low)	 (High)
Speed	0 ~ 6 (0 ~ 3.7)	0 ~ 10 (0 ~ 6.2)
	km / h (mile / h)	

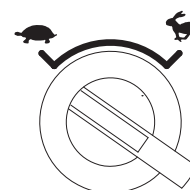

Speed change switch

**IMPORTANT**

Be sure to shift gears while the vehicle is being stopped. Do not shift gears during running.

## 2.1.4 Operating levers / pedals

## Forward-Neutral-Reverse (F-N-R) lever with vibration switch

Moving the F-N-R lever forward or backward makes the machine travel forward or backward respectively. The neutral position brings the machine to a stop. The vehicle speed increases or decreases in proportion to the lever displacement.

Provided at the knob of the lever is the vibration switch for turning on or off the vibration.

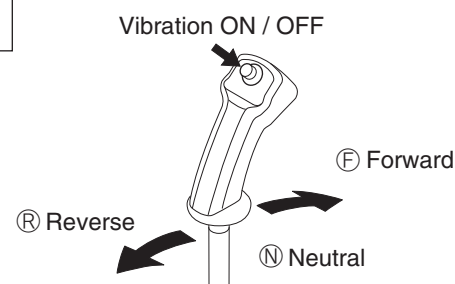
**IMPORTANT**

- For normal braking, return the F-N-R lever back to neutral.
- In an emergency, depress the brake pedal or press the parking brake button.

## 2. OPERATION

### Throttle lever

Shifts the engine RPM.  
The engine RPM increases when moved toward the operator.

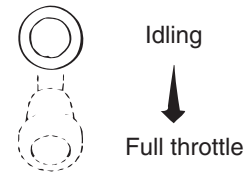

### Leveling blade lift lever (SV400TB-2, SV400FB-2)

The leveling blade is operated from a single control lever.  
The lever has four positions; RAISE, HOLD, LOWER and FLOAT.

**Raise** : To raise the blade, pull the lever backward. The lever automatically returns to the Hold position when released.

**Hold** : When this position is selected, the blade stays in any position.

**Lower** : To lower the blade, push the lever forward. The lever automatically returns to the Hold position when released.

**Float** : Push the lever forward to its full extent. In this position, the blade becomes free to ride up and down over the ground, following the ground configuration as the machine travels. The lever stays in the Float position even if it is released.

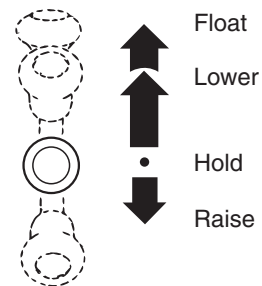

### Brake pedal

In an emergency, push down on the pedal to the full extent, and the machine will come to a sudden stop.

**NOTE:** After depressing the brake pedal, return the F-N-R lever to the  $\textcircled{N}$  position, otherwise the vehicle will not start.

### IMPORTANT

- Do not use the pedal wherever practicable except for an emergency.
- The F-N-R lever permits usual braking.



### 2.1.5 Unloader valve

The unloader valve disengages the drive, playing a role like a clutch. Use this valve for towing the machine when the engine is disabled or when troubles have developed in the hydraulic drive.

For towing:

Turn the knob counter-clockwise (Unload).

For normal traveling:

Turn the knob clockwise (Onload)

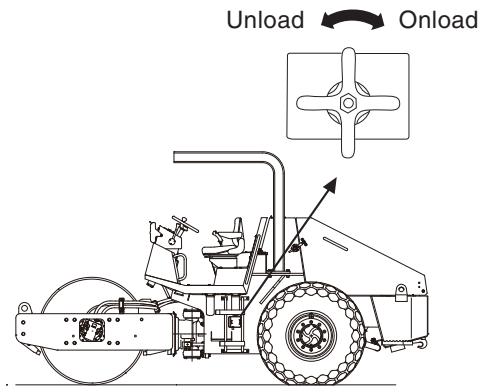

#### ⚠ WARNING

- On a slope, chock the wheels and use extreme care when handling the unloader valve and towing the machine.
- Be sure to apply the parking brake when operating the unloader valve.

**NOTE:** For normal travel, be sure to hold the unloader in the ONLOAD position.

### 2.1.6 Fuse box

#### ⚠ WARNING

When changing a fuse, cut the power supply by turning the starter switch to the OFF position.

Fuses protect electrical components and wiring from burning. Change any fuse which has become powder-coated due to deterioration or which has play between it and fuse holder. To replace fuses, take off the cover. Be sure to use fuses of correct capacity.

Using improperly rated fuses may result in poor machine performance, damage to the electrical system, or safety problems, such as an electrical fire.

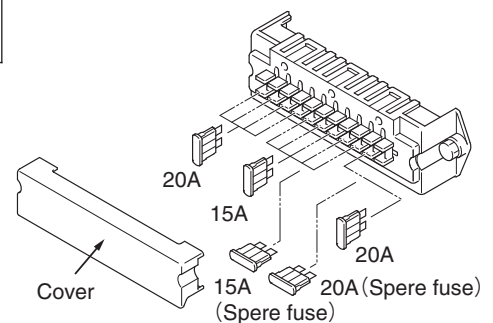

## 2. OPERATION

### 2.2 Handling and Adjustments

#### 2.2.1 Seat adjustment

Adjust the seat for your best operating position. Move the lever as shown by arrow. With the lever held in that position, slide the seat forward or backward as desired. When properly adjusted, release the lever.

Adjust your seat position to suit you as follows:

- 1) Pull the lever ① and adjust seat position longitudinally.
- 2) Turn the backrest adjust dial ② for optimum angle.
- 3) Move the suspension lever ③ to select suitable suspension for your body weight.

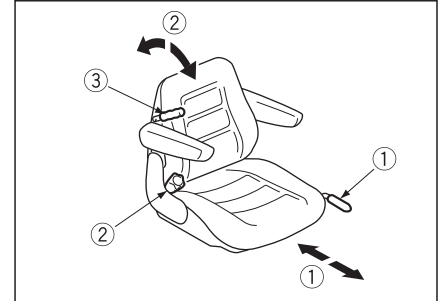

#### **⚠ WARNING**

The adjustment will be necessary when operating the machine first or when operators are alternated.

#### **IMPORTANT**

Be sure to wear the seatbelt during operation.

## 2.2.2 Scraper adjustment and replacement

### SV400D-2

- 1) Clearance adjustment of scraper (A)
  - ① Loosen bolts and nuts (B) at 8 locations.
  - ② Provide a clearance of 20 mm between scraper and the drum.
  - ③ Retighten bolts and nuts (B) at 8 locations.
- 2) Clearance adjustment of scraper (C)
  - ① Loosen bolts (D) at 8 locations.
  - ② Provide a clearance of 20mm between scraper and the drum.
  - ③ Retighten bolts (D) at 8 locations.

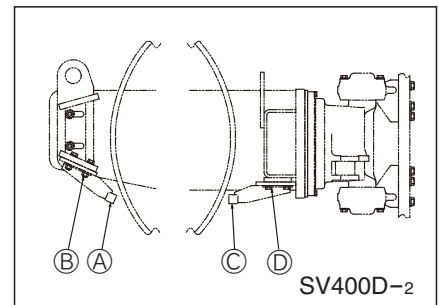

### SV400T-2, SV400TB-2

- 1) Clearance adjustment of scrapers (A)
  - ① Loosen bolts and nuts (B) at 4 locations.
  - ② Provide a clearance of 20mm between scrapers (A) and the drum.
  - ③ Retighten bolts and nuts (B) at 4 locations.
- 2) Replacement of scrapers (A) (9 pieces on top and 9 pieces at bottom.)
  - ① Remove bolts and nuts (C) .
  - ② Replace scrapers (A) with new ones.
  - ③ Refit and retighten bolts and nuts (C) .

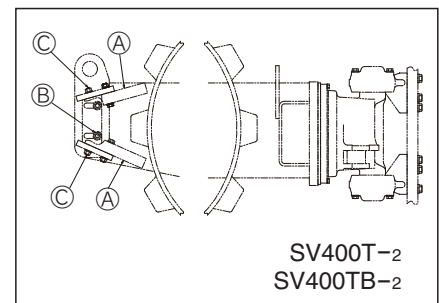

### SV400TF-2, SV400FB-2

- 1) Clearance adjustment of scraper blades (A) .(One at the right and one at the left)
  - ① Loosen bolts and nuts (B) (8 locations respectively at top and bottom)
  - ② Provide a clearance of 20mm between scrapers (A) and the drum.
  - ③ Retighten bolts and nuts (B) (8 locations respectively at top and bottom)
- 2) Replacement of scraper blades (A)
  - ① Remove bolts and nuts (B) (8 locations respectively at top and bottom)
  - ② Replace scraper blades (A) with new ones.
  - ③ Refit and retighten bolts and nuts (B) (8 locations respectively at top and bottom)

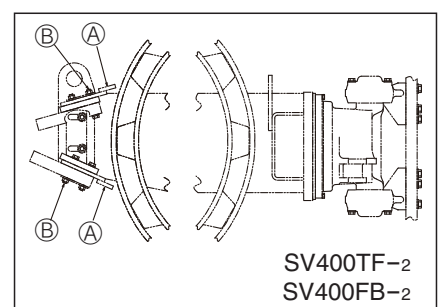

## 2. OPERATION

### 2.2.3 Disengaging the brake when towing

#### **⚠ WARNING**

- On a slope, chock the drums and prepare for towing before disengaging the brake.
- Avoid a long-distance towing.

For towing the machine when the engine is disabled or when trouble has developed in the hydraulic propulsion, system disengage the brake as instructed below:

#### 1) Rear brake

- ① Loosen the lock nuts **(B)**. Tighten bolts **(A)** so as to fasten them onto the pressure plate **(D)**.
- ② Using a wrench, tighten the bolts **(A)** in an alternate sequence by 1/4 turn at a time so as to compress the belleville washers and disengage the braking disks.

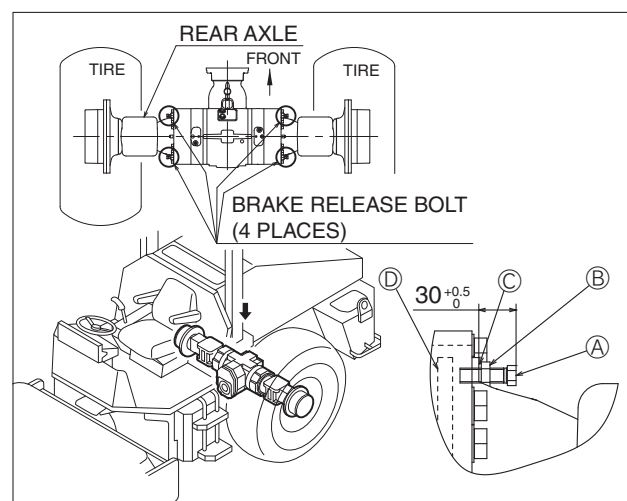

**IMPORTANT**  
Tighten max by one turn.

- ③ After towing is completed, remove bolts **(A)** completely with nuts **(B)** and seals **(C)**. Then replace seals **(C)** apply silicone - based. Tecon Lupu / 101 grease to the bolts **(A)** and install all parts again.
- ④ Adjust bolts **(A)** to obtain a jut of  $30^{+0.5}_0$ mm. Then lock into position with nuts **(B)**.

- 2) Turn the unloader valve counterclockwise to release it.  
Refer to " Unloader valve " on page 25 for its operation method.

#### **⚠ WARNING**

- Do not try to release the brake immediately after a hot engine has been stopped. Let the oil cool down.
- For the brake disengagement, wear hard hat , safety goggles and safety gloves.



## 2.3 Operation

### ⚠ WARNING

- This machine is a one-man roller.
- Operate the machine from the operator's seat.

### 2.3.1 Before-starting inspection

1) Check that the steering lock bar is in the carrying position.

### ⚠ WARNING

Make sure that the steering lock bar is connected in the carrying position before putting the machine in motion. Steering is impossible if the bar is in the steering lock position.

The bar is located at the left of the center of the machine.

To unlock the bar:

- ① Remove the spring pin.
- ② Pull out the lock pin.
- ③ Set the bar in the carrying position.

**NOTE:** Retain the lock bar in the locked position by inserting the lock pin into the lock holes. Fix the lock pin with the spring pin.

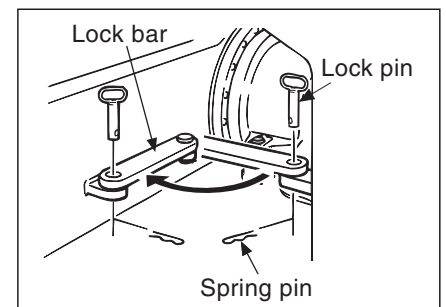
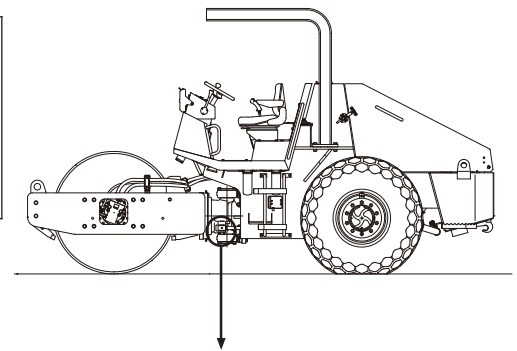

2) Check that the F-N-R lever and is in the neutral position  
 (N).

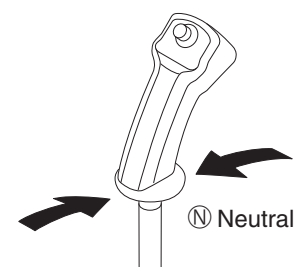

**NOTE:** Set the Forward - Neutral - Reverse (F-N-R) lever in the neutral position and press down the parking brake switch before starting the engine. Unless these conditions are met, the engine will not start.

## 2. OPERATION

### 2.3.2 Starting the engine

#### **⚠ WARNING**

- Check that there are no people or obstacles around the vehicle and beep the horn before starting the engine.
- Set the Forward-Neutral-Reverse (F-N-R) lever in the neutral position and press down the parking brake switch before starting the engine. Unless these conditions are met, the engine will not start.

- 1) Set the throttle lever in a position slightly higher than IDLING.

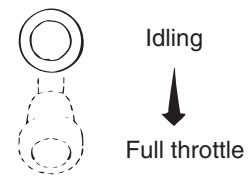

- 2) Turn the starter switch to the ON position and check that the warning lamps and parking brake indicator lamp on the monitor display are on.

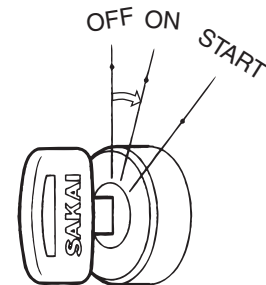
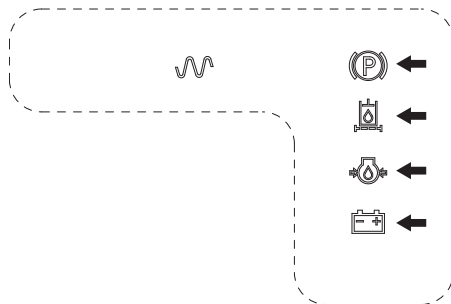

- 3) Turning the key to the START position to start the engine. Release the key the moment the engine has started. The key will automatically return to the ON position.

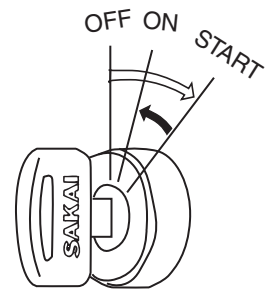

### ⚠ CAUTION

- Do not allow the starter key to stay in the START position for more than 15 seconds.
- If the engine does not start, allow an interval before trying again.
- Check that the warning lamps on the monitor display go off immediately after the engine is started. If any of these warning lamps stay on while the engine is running, shut down the machine, determine the cause and rectify the fault.

### 2.3.3 After starting the engine

Try not to move the machine immediately after starting but practice the following:

### IMPORTANT

**Avoid increasing the engine speed abruptly before warming-up run is completed.**

- 1) Run the engine at around 1,200 rpm for about 5 minutes to warm it up. Warming-up run allows the lubricating oil to reach the vital parts of the engine and hydraulic system, while gradually bringing up the engine oil and hydraulic oil to the working temperature.
- 2) After the warm-up operation, check that:
  - Temperature gauge .....Pointer falls near the center zone.
  - Fuel gauge .....Pointer falls between the E and F marks
  - Charge lamp.....Has gone off.
  - Engine oil pressure warning lamp .....Has gone off.
  - Engine warning lamp .....Has gone off.
- 3) Check for the color of exhaust gas, listen for unusual sounds and vibration. If abnormal, determine the cause and correct the problem.

## 2. OPERATION

### 2.3.4 Traveling



#### ⚠ CAUTION

While travelling, do not turn the starter switch OFF.

#### ⚠ WARNING

- When starting, operate the horn after securing the safety around the machine.
- Be sure to wear the seatbelt during operation.

1) Select the desired speed by the speed change switch.

	 (Low)	 (High)
Speed	0 ~ 6 (0 ~ 3.7)	0 ~ 10 (0 ~ 6.2)

km / h (mile / h)

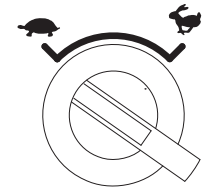

Speed change switch

#### IMPORTANT

Be sure to shift gears while the vehicle is being stopped. Do not shift gears during running.

#### ⚠ WARNING

On a steep slope, run the machine at low speed. Do not attempt to shift speed while travelling.

2) Speed up the engine by pulling the throttle lever towards you.

3) Press down the parking brake switch button to release the brake. Check that indicator lamp  on the monitor display goes off.

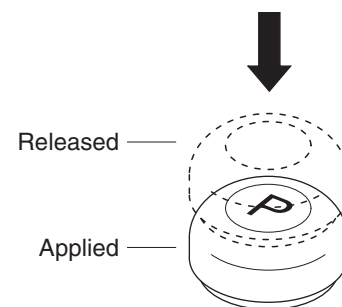



4) Move the F-N-R lever in the direction to travel, and the machine will begin traveling.

**CAUTION**  
**Avoid abrupt operation of the F-N-R lever.**

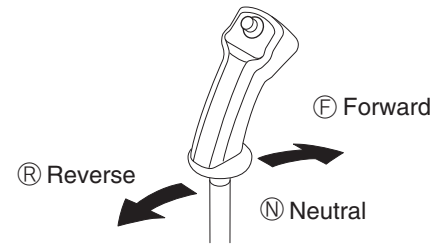

**NOTE:** The travel speed can be controlled by the throttle lever and F-N-R lever.

**WARNING**  
**Pay extreme attention to the area behind the machine when backing, since the space just behind it tends to be a blind spot.**

### 2.3.5 Stopping / Parking

**WARNING**

- **Avoid abrupt braking. Leave enough space for braking safely.**
- **Avoid parking on a grade.**
- **If necessary to park on a grade, block the drums to prevent unexpected moving down the grade.**

1) Bring the F-N-R lever to the neutral position (N), and the machine will come to a halt.

**CAUTION**  
**For normal braking, move the F-N-R lever back to the neutral position. In an emergency, depress the brake pedal.**

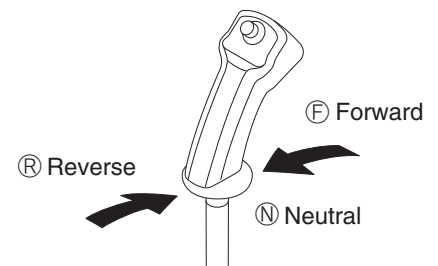

**IMPORTANT**  
**After depressing the brake pedal, return the F-N-R lever to the neutral position, otherwise the vehicle will not start.**

2) Press the parking switch button securely, and check that indicator lamp (P) illuminates.

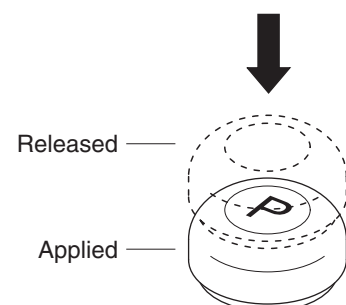

## 2. OPERATION

### 2.3.6 Stopping the engine

- 1) Gradually cool down the engine by running at low idle for about 5 minutes.

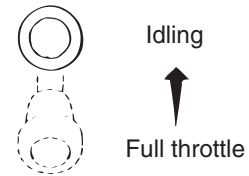

#### IMPORTANT

- Do not bring a hot engine to a sudden stop except for an emergency. This will shorten the life of its component parts.
- Do not allow an overheated engine to come to a sudden stop, but run it at middle idling speed for gradual cooling down before shutting off.

- 2) Turn the starter key to the OFF position to stop the engine.

#### CAUTION

Do not turn the starter switch OFF while the machine is in motion.

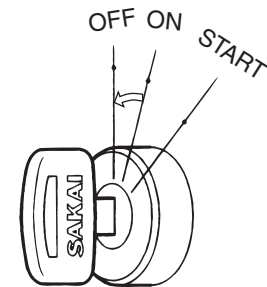

- 3) Remove the starter key.

#### WARNING

- When dismounting from the machine, apply the brake by pressing the parking brake button. If necessary to park on a grade, block the wheels to prevent unexpected moving down the grade.
- Never fail to remove the starter key



### 2.3.7 Check after stopping the engine

- 1) Perform the walk-around checks for oil and water leakage, abnormal signs around the drums.
- 2) Fill the fuel tank.
- 3) Remove waste paper if any from the engine compartment, as this will pose a possible fire hazard.
- 4) Scrape mud or other materials from and around the drums.

## 2.4 Vibratory Operation

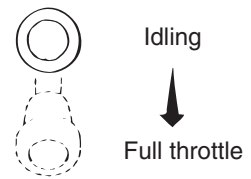
- 1) Run the engine on the full throttle by operating throttle lever or higher by operating the throttle lever.
- 2) Amplitude of vibration is selectable and turned on and off with the vibration switch (A) located on control panel.



-  position: Turning the vibration switch clockwise causes the vibration to start with high amplitude.
-  position: Vibration is shut down.
-  position: Turning the vibration switch counter clockwise causes vibration to start with low amplitude.

**NOTE:** For vibratory rolling, run on full throttle.

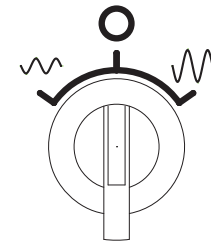

Also, by means of vibration selector switch (B), the selection can be made between the vibration switch (C) installed to the Forward-Neutral-Reverse (F-N-R) lever and the other one located on the panel.

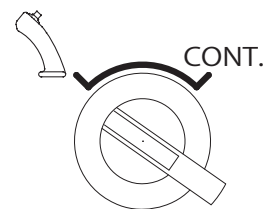

Vibration switch (A)



Vibration selector switch (B)

-  position: Vibration can be turned ON or OFF with the switch located on the Forward-Neutral-Reverse (F-N-R) lever. Pressing this switch causes the vibration to start and pressing it again to stop. This vibration switch on the lever should be used with the vibration switch on the panel placed at  or  position.

CONT position: Have this switch placed at this position when vibration is not to be actuated.

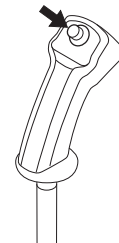

Vibration switch (C)

- 3) Proper travel speed for vibratory compaction is 2 ~ 5 km / h, however, select speeds depending upon job requirements.

### IMPORTANT

- Keep the vibration shut off when the machine is not rolling.
- Stop vibration if the machine has encountered a running difficulty, for example, when it gets stuck in the mud.
- Set the speed change switch in the LOW position during vibratory rolling compaction. Use the HIGH position only for driving on flat straight roads.

## 2. OPERATION

### 2.5 Precautions for Work

#### 2.5.1 Compaction operation

■ **Do not operate the vibration on a hard location**

- Do not work the vibration on a hard surface such as concrete pavement, as this can cause the machine to jump and give abnormal shock load. Damage to shock isolators will result.

■ **Change the direction of travel gently.**

- When changing the direction of travel during asphalt mix compaction, slowly shift the F-N-R lever.

#### 2.5.2 When going downhill

■ **Use the F-N-R lever.**

- Run slowly going downhill. Do not use excessive speed. Avoid changing speed if possible when going downhill. Start slowly and end slowly on steep downgrades.

■ **Use the engine brake**

- Go downhill by applying the engine brake along with the F-N-R lever operation.

**⚠ WARNING**

- **When going uphill, run at low speed. Do not attempt to shift speeds during travelling. The machine can slip down the slope.**
- **When going downhill, adjust the travel speed not to allow the engine speed to exceed 2,500 rpm.**

#### 2.5.3 On a slope

■ **Working on a sidehill**

- Work in an uphill/downhill direction, and avoid working on sidehill with the machine inclining sideways.

## 2.6 Applicable Jobs

1) This machine is mainly used for:

- Static compacting work
- Vibratory compacting work

2) Road rollers do a variety of jobs as listed below.

This machine most effectively handles works or materials marked ☆ .

### Work

- Asphalt road paving
- Dust removal treatment for road
- ☆ Road improvement
- ☆ Embankment construction
- ☆ Dam construction
- Construction of forestry and farm roads
- Foundation building
- Construction of sidewalk, shoulder and gutter foundation

### Material to be compacted

- Asphalt pavement
- ☆ Crusher run
- ☆ Cement concrete
- ☆ Sands
- ☆ Soils
- ☆ Slag
- ☆ Soft rock

### Layers to be compacted

- Surface course, Binder course
- ☆ Base course
- ☆ Subgrade
- ☆ Embankment
- Shoulder
- Sidewalk

## 2.7 After Operation

Check for the coolant temperature, engine oil pressure and fuel level.

Follow the procedures below to prevent the machine from falling into an unworkable condition the following morning caused by muds and other extraneous matter on the drum, or frozen drums:

- 1) Remove muds and water from the machine. Muds can get into the seals together with water drops on the hydraulic cylinder piston rod. Damaged seals will result.
- 2) Park the machine on a hard and dry surface. If such a place is not available, cover the ground with hard plates.
- 3) Low temperature will cause a significant reduction of battery efficiency. Cover batteries or take them off from the machine and store in a warm place for the following day's operation.

## 2.8 Loading and Unloading

### ⚠ WARNING

- Use sturdy ramps with proper width, length and thickness which allow safe loading and unloading.
- If the ramps deflect considerably under load, apply wooden blocks to reinforce them.
- Loading should be conducted on a level and hard ground. Leave a sufficient distance between the machine and the shoulder.
- To prevent slippage on the ramps, keep the drums free from mud, oils, etc. The ramps must also be free of grease, oil and ice.
- Do not steer the machine on the ramps. If the machine is facing in the wrong direction, allow it to dismount from the ramps and correct the direction.

For loading and unloading, use ramps or a proper loading stand.

### 2.8.1 Use of a trailer equipped with a winch

### ⚠ WARNING

Placing the unloader valve in UNLOAD position disrupts the power for traction. Do not enter the areas ahead of and behind the machine. It is very dangerous.

- 1) Engage the trailer brake and chock its wheels. Fix the ramps so that the machine and trailer are completely aligned.
  - ☆ The angle between the ramps and ground must be less than 15 degrees.
  - ☆ Leave a proper space between the ramps according to the width of the roller drum.
- 2) Decide the correct direction of run and make the machine run forward to the ramps.

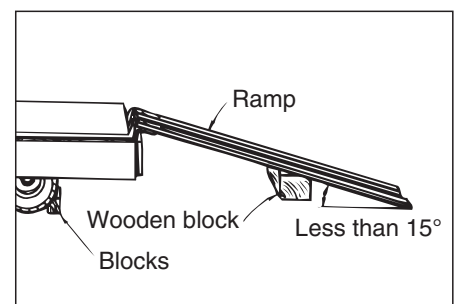

## 2. OPERATION

- 3) Draw the wire rope from the trailer winch and put its hook on the hooking point ① or ② ( One each on right and left ) of the roller.
- 4) Place the unloader valve located at the operator's station to the UNLOAD position (See "Unloader valve" on page 25).
- 5) With the engine running at idle, perform loading by means of the trailer winch.
- 6) When the loading is completed, set the unloader valve back in the ONLOAD position.
- 7) Locate the machine correctly on the trailer.

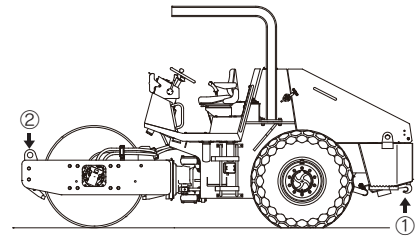

### 2.8.2 Self-propelling

- 1) Engage the trailer brake and chock its wheels. Fix the ramps so that the machine and trailer are completely aligned.
  - ☆ The angle between the ramps and ground must be less than 15 degrees.
  - ☆ Leave a proper space between the ramps according to the width of the roller drum.
- 2) Decide the correct direction of run and conduct loading or unloading at low speed.
  - For loading, run forward at low speed.
  - For unloading, run backward at low speed.
- 3) Locate the machine correctly on the trailer.

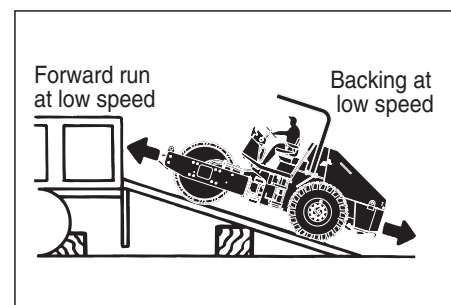
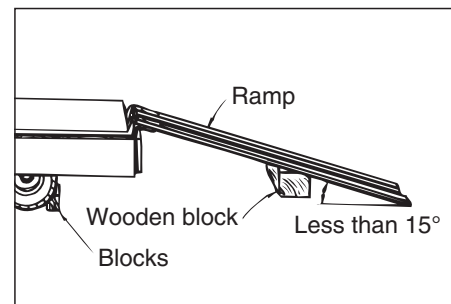



## 2.9 After Loading the Machine

When the machine has been located properly on the trailer, tie it down as follows:

- 1) Press the parking switch button to apply the parking brake. Place wooden blocks under the drums to prevent movement.
- 2) Fix the machine with ropes tied at the front and rear towing hook holes. Particularly, pay attention to sideways skidding.

## 2.10 Transportation

### **⚠ WARNING**

**To decide the transporting route, check the width of the road, height and weight (including the roller) of the trailer.**

For transportation, obey traffic regulations.

## 2.11 Operation in Cold Weather

In cold weather, take the following measures to prevent troubles such as starting difficulty and coolant freeze-up.

### 2.11.1 Fuel oil and grease

Use fuel and oil with low viscosity. See "Rating" on page 64.

### 2.11.2 Coolant

#### **⚠ WARNING**

**Do not bring an open flame to the antifreeze or do not smoke when handling it. It is inflammable.**

#### **⚠ CAUTION**

**NEVER use methanol-, ethanol- and propanol-base antifreeze.**

Use soft water for coolant.

In freezing weather, add antifreeze to the coolant referring to the table below. Select the most suitable mix ratio according to the lowest temperature in the job location.

## 2. OPERATION

Ambient temperature	Always
Amount of anti-freeze	6.5 ℓ (1.7gal)
Amount of water	6.5 ℓ (1.7gal)
Ratio	50%

Our vehicles are filled with a long-life coolant (non-amine type).

The validity of the antifreeze is for two years.

Use non-amine type long-life coolant when changing coolant.

### 2.11.3 Battery

#### **⚠ WARNING**

- **Batteries generate explosive gases. Do not use an open flame close to batteries.**
- **The battery electrolyte is corrosive. Keep the electrolyte away from your eyes and skin. If you are affected by the electrolyte, flush with large quantities of water and get medical help.**

At low temperature, batteries are less efficient. The level of charge is lowered and batteries will tend to freeze. Maintain batteries fully charged wherever practicable, and give attention to heat insulation at night for the next day's operation.

Check the color of the hydrometer attached to the battery top to charge or replace the battery.

Green ····· Good

Black ····· Discharged too much

White ····· Checking required

## 2.12 When the Cold Season is Over

When winter is over and the warm season has come, proceed as follows:

- 1) Change oil and fuel with those for use in warm season referring to “Rating” on page 64.
- 2) If AF-PT antifreeze is in use, drain the coolant completely, wash clean inside the cooling system, and then fill with clean water (city water).

## 2.13 For a Long Storage Period

For leaving the machine unused for longer than one month, proceed as follows:

- 1) Store the machine in a closed area after cleaning.
- 2) Conduct oiling, greasing and changing of oil.
- 3) Grease lubricate the exposed portion of hydraulic cylinder piston rods.
- 4) Cover the battery after disconnecting the negative cable or take off the battery from the machine and store in a safe place.
- 5) If the temperature is expected to go down below 0°C, add antifreeze to the coolant.
- 6) With F-N-R lever placed at neutral position  $\textcircled{N}$  and vibration switch at  $\textcircled{O}$  (OFF) position, have the parking brake engaged.
- 7) Chock the machine.
- 8) Remove the starter switch key.

## 2.14 During the Storage Period

### **⚠ WARNING**

**If necessary to operate the machine in indoor storage space, ensure good ventilation keeping windows and doors open to prevent gas poisoning.**

- During storage, operate the machine at least once a month to prevent the oil films on the lubricated parts from deteriorating and to charge the batteries.
- To prevent the brake linings from sticking to the brake drum, disengage the brake once a month. Exercise care not to allow the machine to move unexpectedly.

## 2. OPERATION

### 2.15 When the Battery Has Discharged

#### ⚠ WARNING

- To check and handle the batteries, keep the engine stopped with the starter switch in the OFF position.
- The batteries give off explosive gases. Do not smoke close to the batteries. Keep flames and sparks away from the batteries.
- The electrolyte is very corrosive and will harm your clothing or skin. If the electrolyte has come into contact with your clothing or skin, flush with sufficient amount of water. In case the electrolyte has gotten into your eyes, flush with water and get medical help.
- To disconnect the battery cables, start with the negative terminal (earth). When connecting, start with the positive terminal. Do not allow a metallic item to bridge between the positive terminal and machine body. This can generate sparks, causing an explosion.
- Loose battery terminals can cause sparks. An explosion will result. When connecting the terminals, make certain that they are tight.

Disconnect with negative cable first

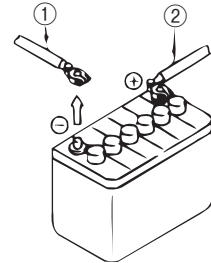

Connect with positive cable first

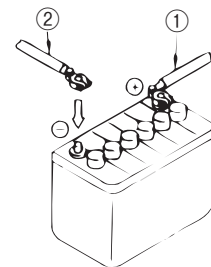

#### 2.15.1 Connection and disconnection of booster cables

When jump-starting the engine, connect the booster cables as follows:

##### ■ Connection of booster cables

- 1) Connect one end of the positive booster cable (A) to the positive (+) terminal of the dead battery on the machine.
- 2) Connect the other end of the positive booster cable to the positive (+) terminal of the live power supply.
- 3) Connect the negative live power cable (B) to the negative (-) terminal of the booster supply.
- 4) Connect the other end of the negative booster cable to a good earth ground on the engine block of the machine.

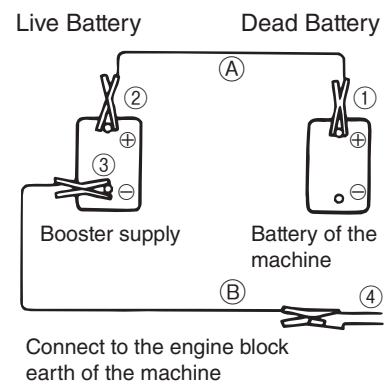

■ **Disconnection of booster cables**

- 1) Disconnect the negative booster cable (B) from the engine block earth.
- 2) Disconnect the negative booster cable (B) from the booster supply.
- 3) Disconnect the positive booster cable (A) from the booster supply.
- 4) Disconnect the positive booster cable (A) from the machine.

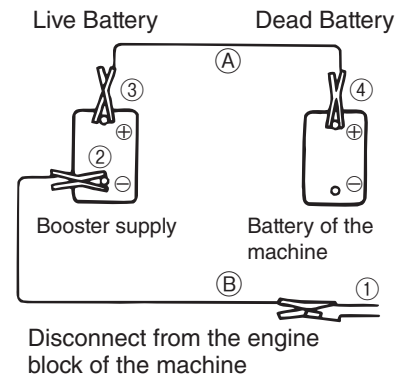

⚠ **WARNING**

- Do not allow the positive (+) terminal to make contact with the negative (-) terminal when connecting the booster cables.
- Wear safety goggles when jump-starting the engine.
- Do not allow the machine to make contact with the booster supply.
- Do not make wrong connections. Connect the negative (-) cable to the engine block earth far away from the battery, as sparks may occur when connecting.

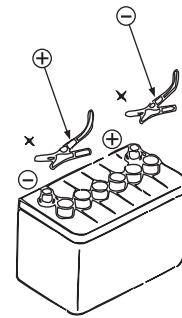

⚠ **CAUTION**

- Use booster cables and end clips of proper size suited to the battery capacity.
- Use the batteries of the equal capacity for the machine and booster supply.
- Check booster cables and end clips for signs of damage and corrosion.
- Securely connect the clips.

### 3. PERIODIC MAINTENANCE

#### 3.1 Precautions

Whether or not the inspection service and lubrication are performed at the correct regular intervals exerts significant influence on the occurrence of problems and service life of the machine. In this manual, typical intervals for inspection and service are given. However, flexibility should be exercised as to interval or type of services to enable your machine to always operate in the best condition.

#### IMPORTANT

**After maintenance and inspection, record the result of inspection. Remember that replacement of filters and elements, replenishment and change of oil and grease, and cleaning of the radiator fins is important.**

#### General precautions:

- 1) Always use Sakai genuine parts for replacement.
- 2) Use lubricants recommended by Sakai. Avoid mixing different brand lubricants.
- 3) For hydraulic oil replenishment, changing, level checking, filter cleaning or replacement, oiling and greasing, use extreme care to prevent dust from entering.
- 4) For checking oil level or changing oil, park the machine on a level and hard surface.
- 5) Change oil while its temperature remains high after operation.
- 6) For a long-term storage, fill the fuel tank, lubricate necessary points and run the machine for more than 20 minutes once a month.
- 7) In freezing weather, add antifreeze to the coolant according to the ambient temperature.
- 8) For the hydraulic pump and motor, have them serviced at authorized service shops.
- 9) Turn the starter switch OFF when performing services such as repairing broken wires, short circuits and tightening loose terminals.

#### Periodic Replacement of Essential Maintenance Parts

In order secure safety for work and travel, conduct inspection and services.

Further, for enhanced safety, following parts and components should be replaced periodically. These parts are prone to material deterioration due to aging or physical change due to friction, it is difficult to determine their useful limit by regular inspection, which makes it necessary to replace with new ones after certain period of service to ensure they function as intended.

If any defects are detected such as crack, deformation or oil leakage, go ahead and replace them even if it is within scheduled replacement time.

### 3. PERIODIC MAINTENANCE

System or Mechanism	Part name	Periodical replacement maintenance part	Replacement period	Remarks
1.Brake system	Master cylinder	Seals (rubber parts)	2 years	Adopted machines only
	Wheel cylinder	Seals (rubber parts)	2 years	//
	Brake piping parts	Brake hose	2 years	
		Air hose	2 years	Adopted machines only
Operating parts	Cable	4 years	//	
2. Steering system	Orbitrol	Seals (rubber parts)	2 years	
	Hydraulic piping parts	Hydraulic hose	2 years	
	Steering cylinder	Seals (rubber parts)	2 years	
	Hydraulic pump	Seals (rubber parts)	4 years	
3. Power transmission system (inclusive of axle)	Axle	Seals (rubber parts)	4 years	Adopted machines only
	Travel pump	Seals (rubber parts)	4 years	//
	Travel motor	Seals (rubber parts)	4 years	//
	Hydraulic piping parts	Hydraulic hose	4 years	//
	Isolation rubber	Isolation rubber itself	4 years	//
4. Fuel system	Piping parts	Fuel hose	4 years	
5. Engine related	Engine mounting parts	Isolation rubber	4 years	
	Seals (rubber parts)	Packing and others	4 years	
	Drive parts	V-belt	2 years	
6. Cooling system	Piping parts	Radiator hose	2 years	
7. Control related parts	Cable	Cable	4 years	Adopted machines only

#### CAUTION

- **With a new machine, change the engine oil and change the engine oil filter elements after 50 hours of operation for the first time only. (Refer to page 58)**
- **When trouble occurs in the location indicated by the indicator lamp on the dashboard display, sensor will work and the corresponding lamp comes on. If this occurs, conduct necessary service regardless of the periodic service interval recommendation.**
  - 1) **The hydraulic filter (line filter) warning lamp ⇨ Replace elements**
- **Check the electric wiring at a regular interval not exceeding one month:**
  - 1) **Damage to the wire harness and loose clamps**
  - 2) **Loose sockets**
  - 3) **Function of electrical systems**

### 3. PERIODIC MAINTENANCE

#### 3.1.1 Lifting the machine on a hoist

##### **⚠ WARNING**

- Get a qualified personnel to lift and lower the machine on a hoist.
- Use sturdy wire ropes.
- Lock articulation by means of lock bar located at the center of machine.

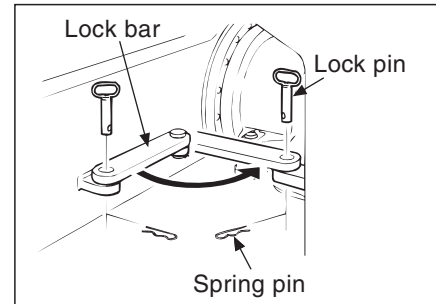

##### **⚠ CAUTION**

**Remove POPS before starting lifting work.**

- 1) Put wire ropes securely on the hook and lifting points as shown.
- 2) If wire ropes make contact with other parts of the machine, put pieces of cloth or wooden blocks at the contact points. Carefully perform lifting.
- 3) When lifting, keep the machine properly ballanced.

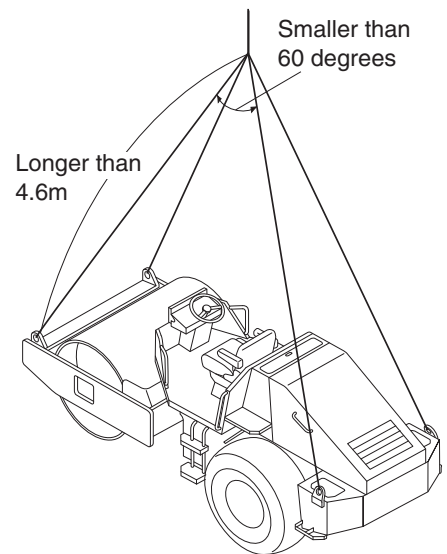



### 3.2 Walk-around Checking

For efficient operation, daily, before-operation checking is very important. Before starting, perform walk-around checking for loose bolts, nuts and signs of leakage in addition to items as shown below:

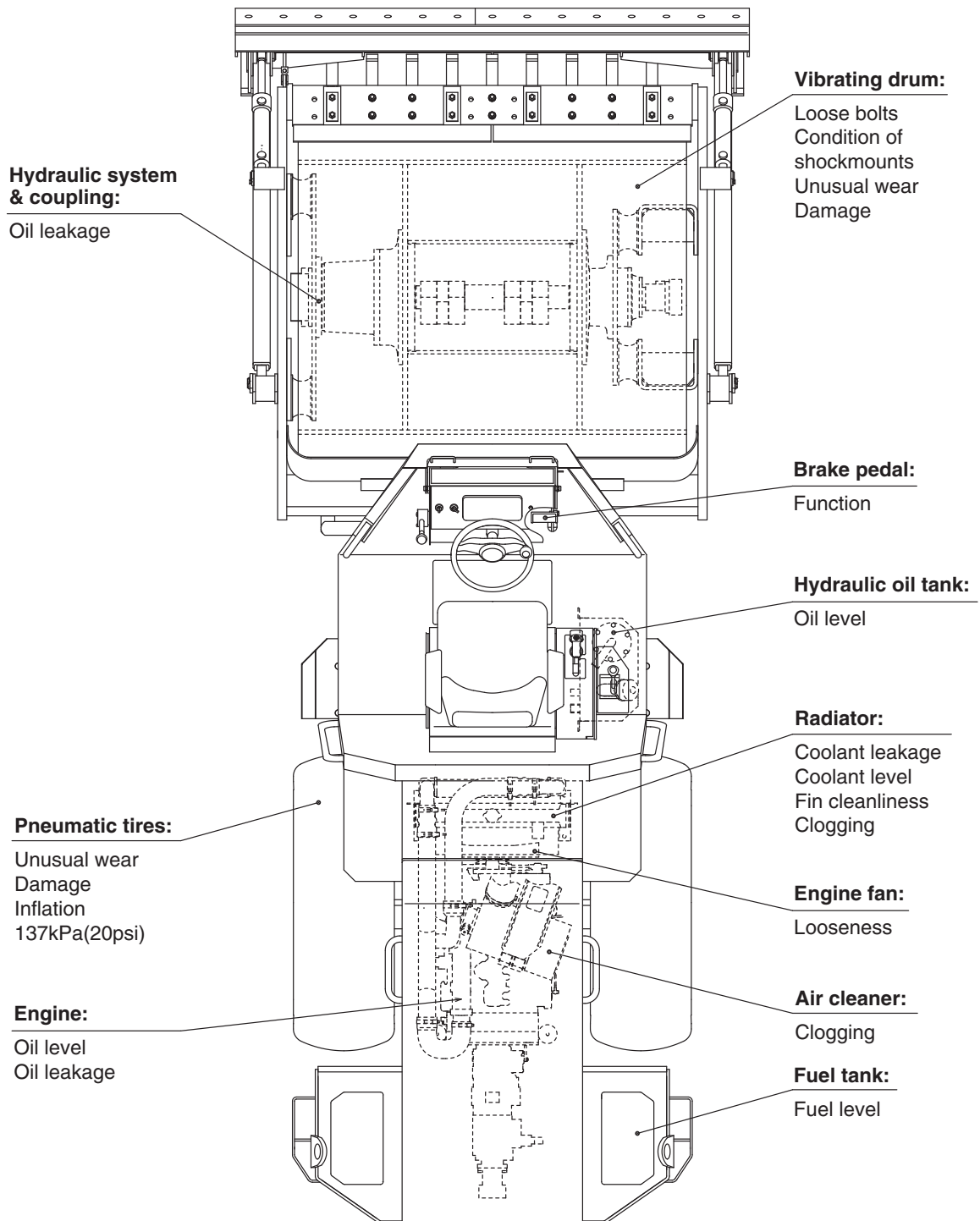

### 3.3 Periodic Maintenance Points

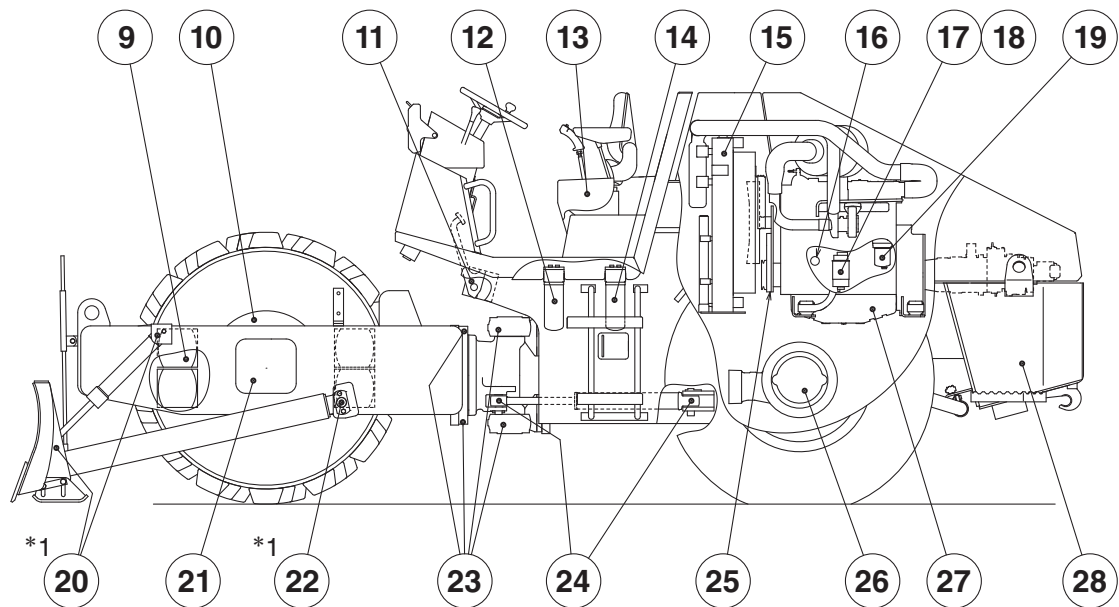
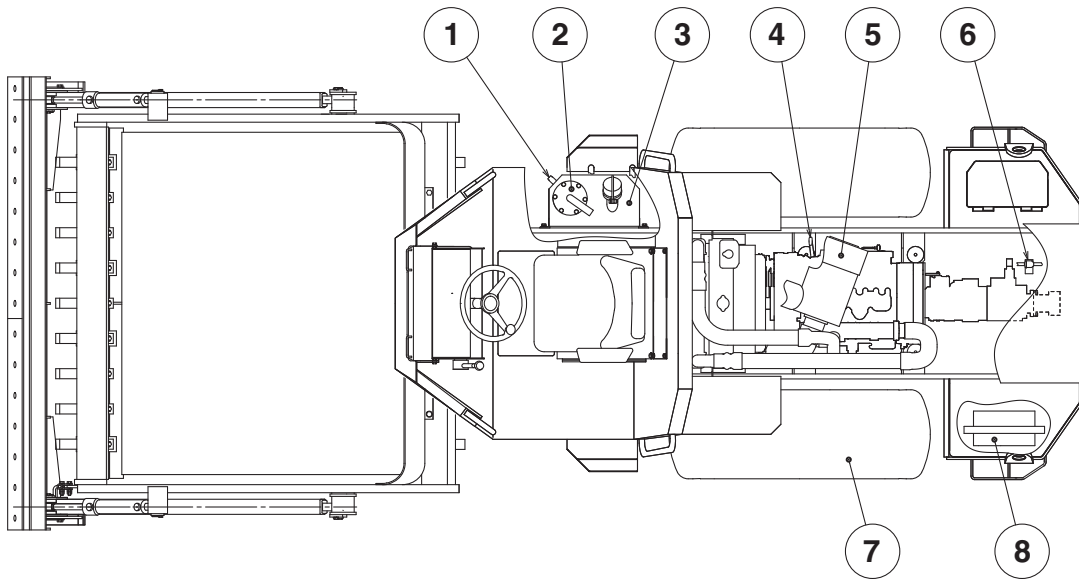

\*1 SV400TB-2, SV400FB-2 only

### 3. PERIODIC MAINTENANCE

Interval	Ref. No.	Item	Service	Lubricant	Q'ty
Every 10 service hours or daily	④	Engine oil level gauge	Check oil level		1
	⑮	Radiator and reservoir	Check water level	Coolant	1
	⑳	Fan belt and water pump belt	Check tension and adjust		1
Every 50 service hours	①	Hydraulic oil level gauge	Check oil level	Hydraulic oil	1
	⑤	Air cleaner	Check indicator		1
	⑧	Battery	Check hydrometer		1
	⑰	Fuel sedimenter	Check, drain water and dirt		1
	*⑳	Cylinder head and anchor pins	Grease 4 places	Grease	4
	*㉒	Push rod anchor pin	Grease 2 places	Grease	2
Every 250 service hours	⑨	Rubber dampers	Check for cracks		8
	⑩	Vibrator	Check oil level	Gear oil	1
	⑪	Brake	Grease 1 place	Grease	1
	㉑	Gear case : Wheel motor	Check oil level, add as necessary	Gear oil	1
	㉓	Center pin and tilt pin bearings	Grease 4 places	Grease	4
	㉔	Cylinder head and anchor pins	Grease 4 places	Grease	4
	㉖	Differential and final drive	Check oil level, add as necessary	Gear oil	1
Every 500 service hours	⑥	Fuel pre - filter	Change fuel pre - filter		1
	⑫	Hydraulic oil return filter	Change filter element		1
	⑬	Control link	Check for loose bolts and nuts, and adjust rods		1
	⑭	Hydraulic oil line filter	Change filter element		1
	⑰	Engine oil filter	Change filter cartridge		1
	㉖	Differential and final drive	Change gear oil	Gear oil	1
	㉗	Engine oil pan	Change engine oil	Engine oil	1
Every 1000 service hours	②	Hydraulic oil suction filter	Clean filter element		1
	③	Hydraulic oil tank	Change hydraulic oil	Hydraulic oil	1
	⑩	Vibrator	Change gear oil	Gear oil	1
	⑯	Fuel strainer	Check / clean fuel strainer		1
	⑱	Fuel filter	Change filter cartridge		1
	㉑	Gear case : Wheel motor	Change gear oil	Gear oil	1
When required	⑤	Air cleaner	Clean element		1
	⑦	Tires	Check inflation		2
	㉘	Fuel tank	Drain water and dirt		1

\* SV400TB-2, SV400FB-2 only

### 3. PERIODIC MAINTENANCE

#### 3.4 Maintenance Procedure

➔ For servicing the engine, see the separate engine manual.

##### (1) Every 10 hours or daily

##### ④ Engine oil level gauge

Shut down the engine and check the engine oil level. If it is not between MAX and MIN marks, add oil through the fill hole.

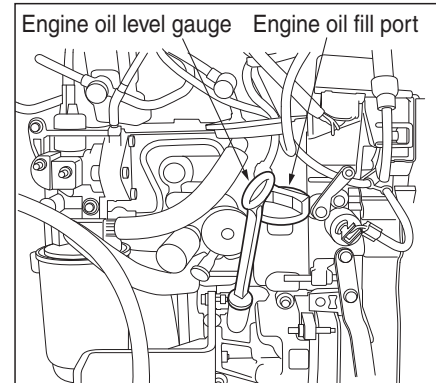

##### ⑮ Radiator and reservoir

Check to see coolant in reservoir is up to level mark and replenish with water. Use soft water only.

##### ⚠ CAUTION

- With radiator cap removed, feed water nearly up to filler port, then replenish the reservoir as well.
- If level is below LOW mark, remove reservoir cover and replenish with fresh water up to FULL mark.

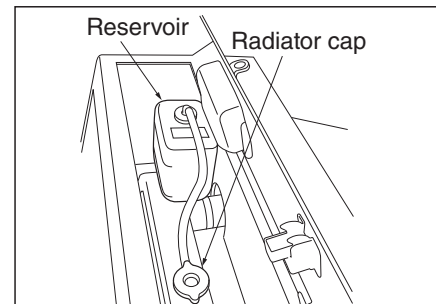

##### ⚠ WARNING

Do not remove the radiator cap while the coolant is hot.



**NOTE:** Replace a coolant every two years.

②⑤ **Fan belt and water pump belt**

➔ See the separate engine manual.  
Check tension and adjust.

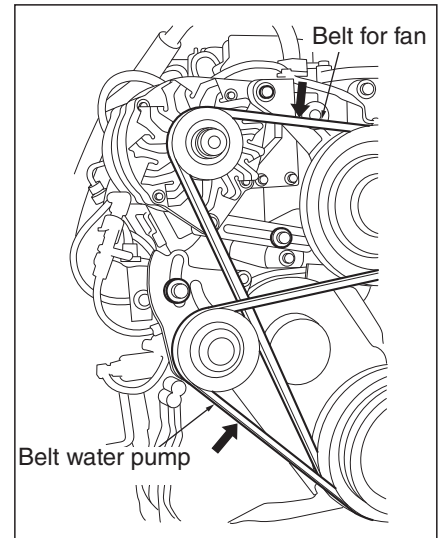

(2) Every 50 hours

① **Hydraulic oil level gauge**

Check the oil level with the sight glass on the side of tank.  
The level is proper if it is between H and L marks when cold.  
Of necessary, add the hydraulic fluid from the fill port.

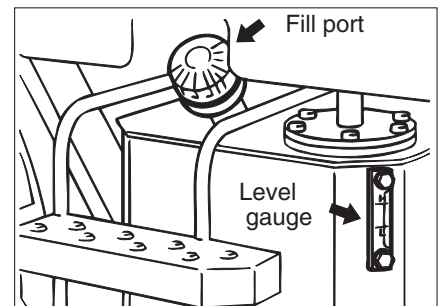

⑤ **Air cleaner**

When the red float of the dust indicator reaches the service level (a mark on the indicator), clean the element (see page 60).

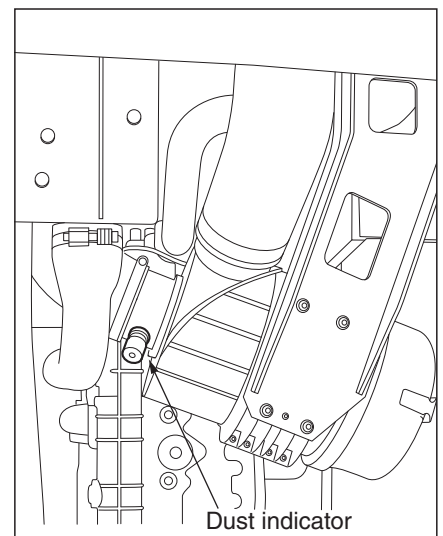

### 3. PERIODIC MAINTENANCE

#### ⑧ Battery

- 1) Check the condition of the battery and replace it as necessary.  
Check the color of the hydrometer atop the battery to confirm the condition of the battery.  
Green ..... Satisfactory  
Black ..... Charging is necessary  
Semitransparent Replacment is necessary
- 2) When the terminal is loose, tighten it sufficiently, and thinly apply vaseline or grease to prevent rusting.

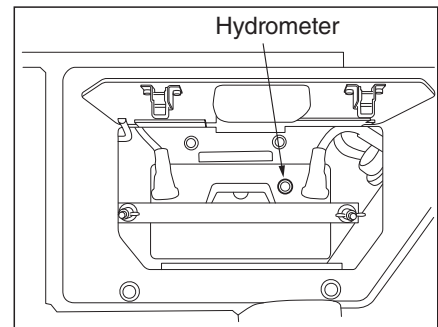

#### ⑰ Fuel sedimenter

Loosen the drain plug in the lower part of the sedimenter to drain water.

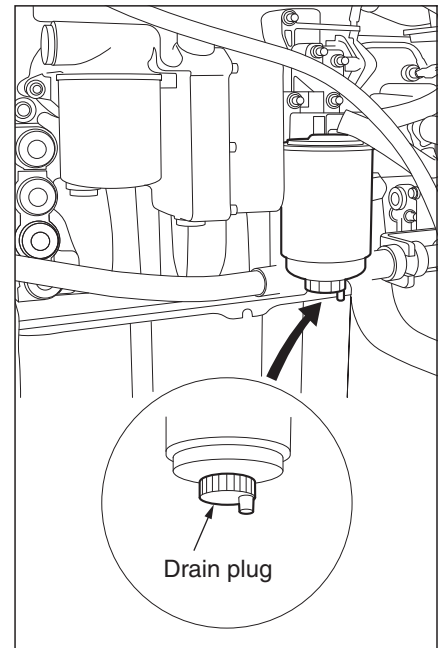

#### ⑳ Cylinder head and anchor pins (For model SV400TB-2, SV400FB-2)

#### ㉓ Push rod anchor pin (For model SV400TB-2, SV400FB-2)

Apply grease

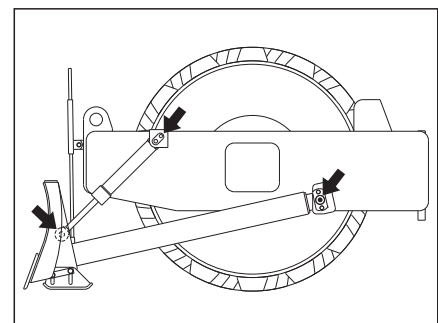

**(3) Every 250 hours**

**⑨ Rubber dampers**

Check the rubber blocks for cracks, and their mounting bolts for looseness.

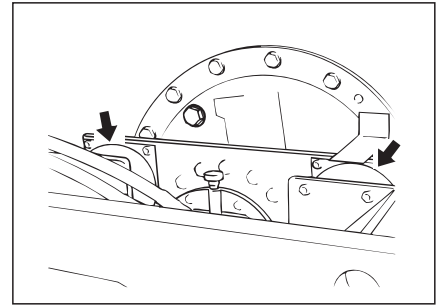

**⑩ Vibrator**

Check for the oil level and leakage.

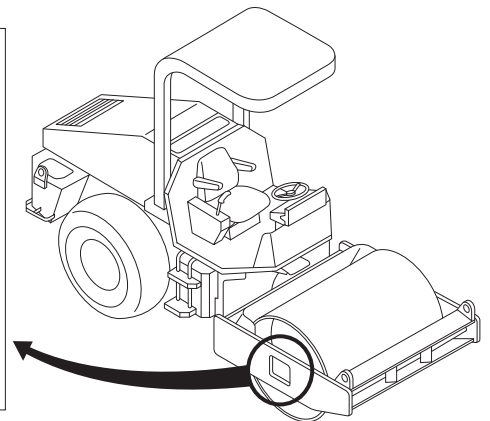
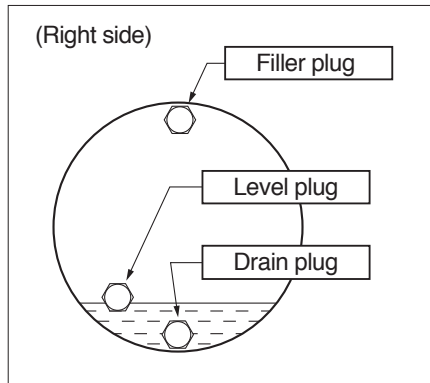

**⑪ Brake**

Apply grease to the brake pedal bracket.

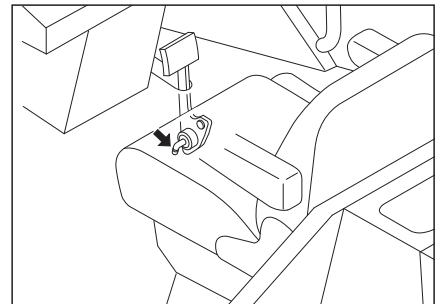

**⑫ Gear case : Wheel motor**

- 1) Position the drum so that the drain plug comes to the bottom.
- 2) Check for oil level, and add oil through the fill port as necessary.

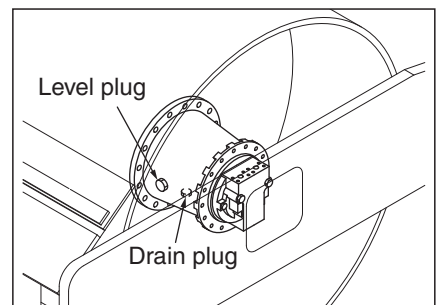

### 3. PERIODIC MAINTENANCE

#### ②③ Center pin and tilt pin bearings

Apply grease at 4 locations.

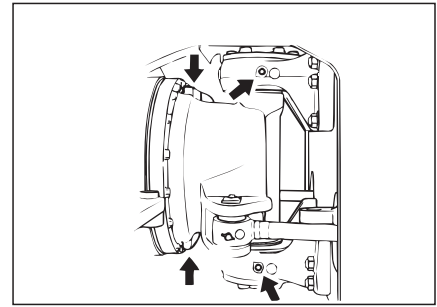

#### ②④ Cylinder head and anchor pins

Apply grease at 4 locations.

The steering cylinder is provided on both sides of the machine.

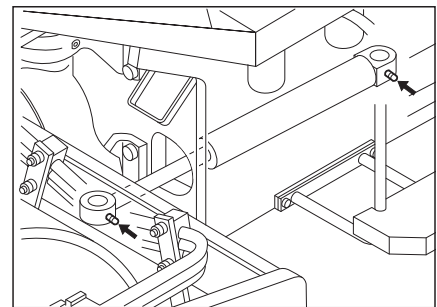

#### ②⑥ Differential and final drive

Check for oil level, and add oil through the fill port as necessary.

〈Differential ①〉

Fill port plug and Level plug  
(Fill port and Level port)

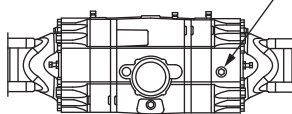

〈Final drive ②〉

Level plug  
(Level port)

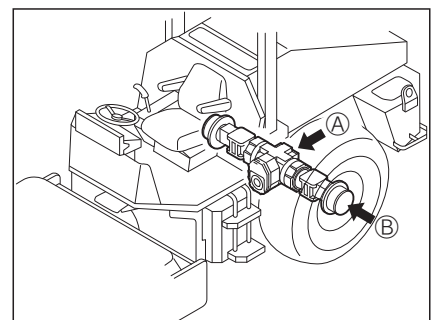
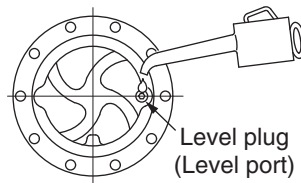



**(4) Every 500 hours**

**⑥ Fuel pre - filter**

Change the pre - filter.

**IMPORTANT**

**Pay attention to the direction of installation when installing the filter.**

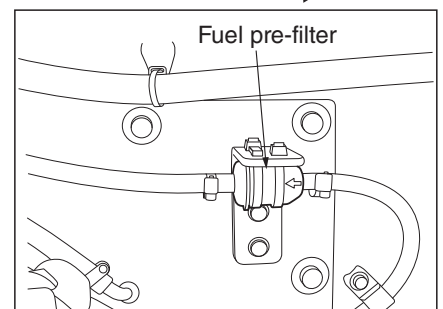
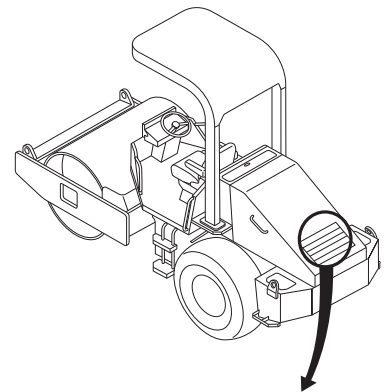

**⑫ Hydraulic oil return filter**

**⑭ Hydraulic oil line filter**

Change the elements.

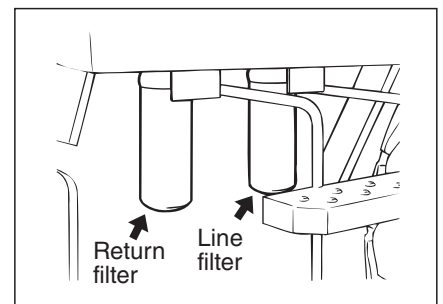

**⑬ Control link**

- 1) Check the nuts for looseness. Adjust the rod.
- 2) Apply grease to F-N-R lever shaft.

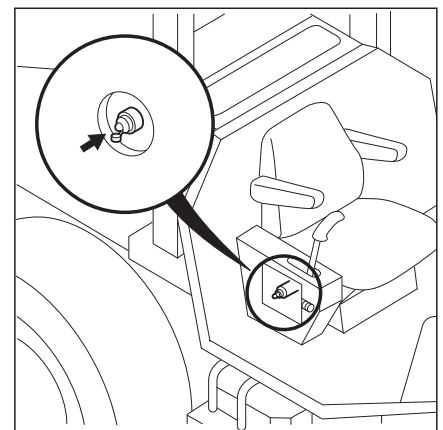

### 3. PERIODIC MAINTENANCE

①⑨ Engine oil filter

②⑦ Engine oil pan

➔ See the separate engine manual.

- 1) After completion of operation and while the oil is warm, drain the oil with the drain plug ① removed.

#### ⚠ WARNING

When draining a hot oil, use care not to get burned.

- 2) Refit the drain plug ① and fill the crankcase with the engine oil from the fill hole ② .
- 3) Change the oil filter ③ .

**NOTE:** For a new machine, change oil at 50 operating hours for the initial time only.

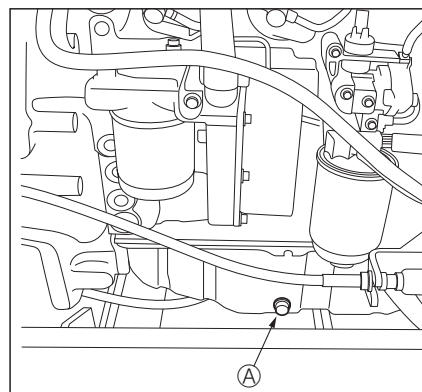
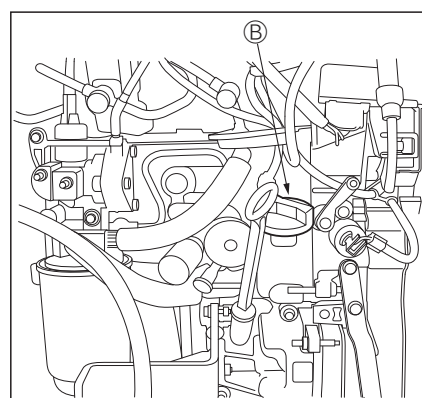
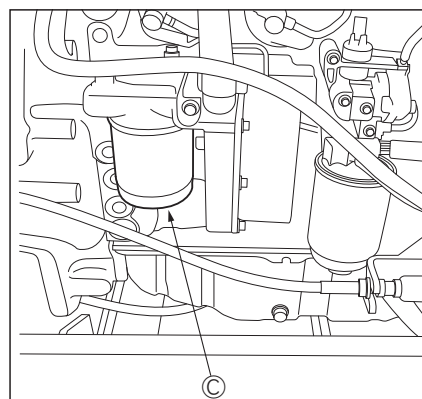

②⑥ Final drive

- 1) Rotate the wheel till the drain port is located at the lowest position. Remove plug to drain oil.
- 2) At the final drive, adjust the position of plug until it is parallel to the ground.
- 3) Fill oil through the fill port till oil overflows from the level port.
- 4) When the final drive case is filled to the specified level, refit the removed plugs.

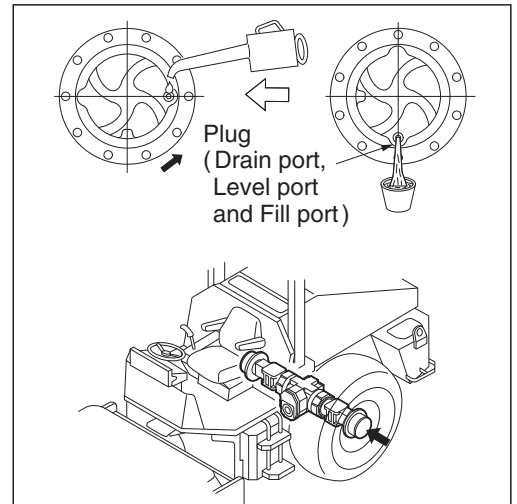

②⑥ Differential case

- 1) Drain oil by removing the drain plug, fill port plug and level plug.
- 2) Refit the drain plug.
- 3) Fill oil through the fill port till it overflows from the level port.
- 4) Refit the removed plugs.

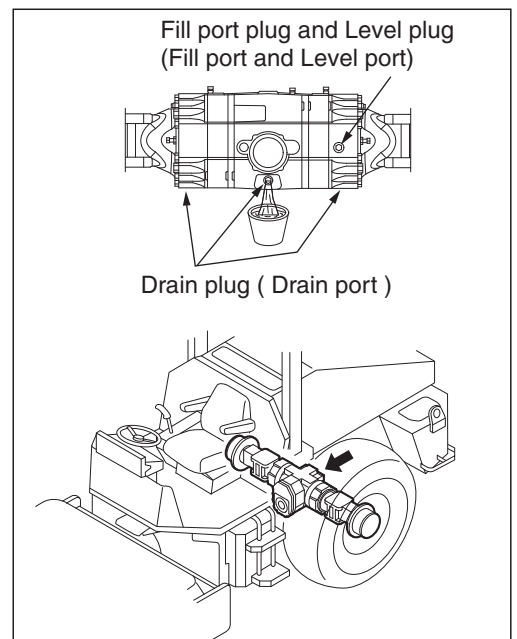

### 3. PERIODIC MAINTENANCE

#### (5) Every 1,000 hours

##### ② Hydraulic oil suction filter

Take off the hydraulic tank cover. Take out and clean the strainer, change the strainer if necessary.

##### ③ Hydraulic oil tank

- 1) Remove the drain plug, and drain oil while it is warm.
- 2) Clean inside of the tank, and fill fresh oil to the specified level.
- 3) Start and run the engine at idling for 2 to 5 minutes. When the hydraulic oil has become free from air bubbles, stop the engine and recheck the oil level.

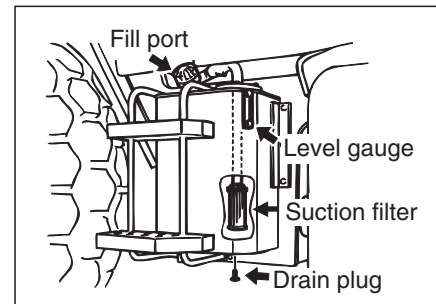

#### ⚠ WARNING

When draining a hot oil, use care not to get burned.

##### ⑩ Vibrator

- 1) Rotate the drum till the drain plug comes to bottom.
- 2) Remove drain plug, level gauge plug and filler plug.
- 3) Drain oil from vibrator.
- 4) Clean the vibrator before reinstalling it.
- 5) Feed oil at filler port until oil flows out of level gauge hole.
- 6) Reinstall the level gauge plug as well as filler plug after cleaning them.

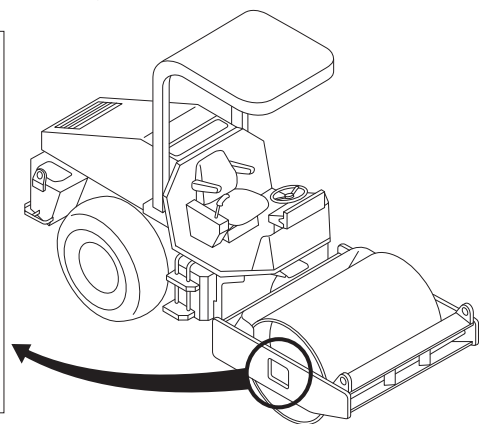
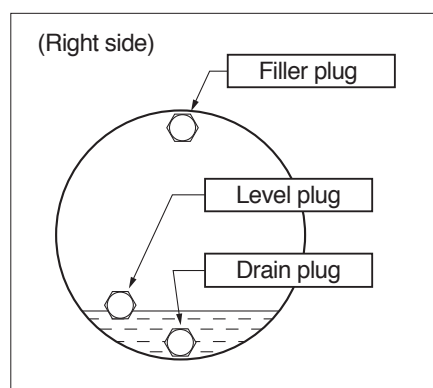

#### ⚠ WARNING

When draining a hot oil, use care not to get burned.

#### ⚠ CAUTION

The oil capacity of the vibrator is 21 liters each. Do not fill more than 21 liters.

⑩ Fuel strainer

➔ See the separate engine manual.  
Clean the strainer.

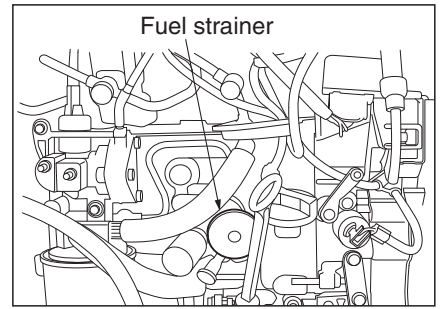

⑱ Fuel filter

➔ See the separate engine manual.  
Change the filter cartridge.

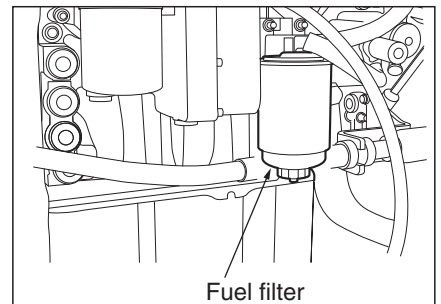

⑳ Gear case : Wheel motor

- 1) Position the drum so that the drain plug comes to the bottom.
- 2) Remove the drain plug and drain the oil while it is warm.
- 3) Rotate the drum so that a drain hole may come to top. Refit the drain plug and fill the oil through the fill hole until it overflows at the level hole.
- 4) Refit the level plug and drain plug.

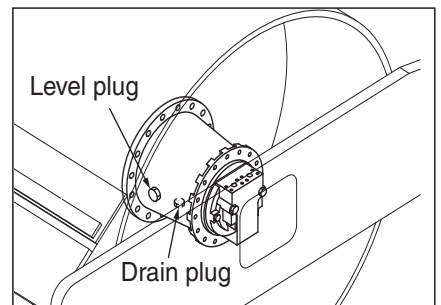

### 3. PERIODIC MAINTENANCE

#### (6) As required

##### ⑤ Air cleaner

When the red float of the dust indicator reaches the service level (a mark on the indicator), clean the element as described below:

- 1) Pull the clip and turn the cover 12 degrees counter clockwise to remove it. With draw the element.
- 2) Blow compressed air from inside of the element.

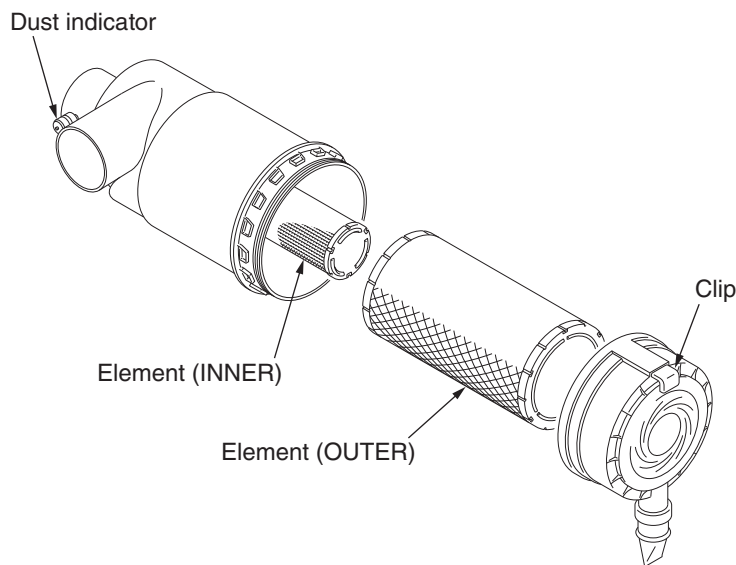

#### **⚠ WARNING**

**Exercise caution not to get a speck of dust in your eye.**

- 3) Check the element for any damage and replace as necessary, before pushing the dust indicator reset button.
- 4) Reinstall the element and fix the cover with the clip.  
Turn the cover 12 degrees clockwise and push in the clip to fit it.

**NOTE:** In normal use, change the other element once in every six cleanings.

#### **⚠ CAUTION**

**Replace the element when the red float reaches the service level even if it is cleaned.**

⑦ **Tires**

- 1) Check for unusual wear and damage.
- 2) Check for the inflation. 137 kPa {20 psi}
- 3) Check the wheel nuts for looseness.

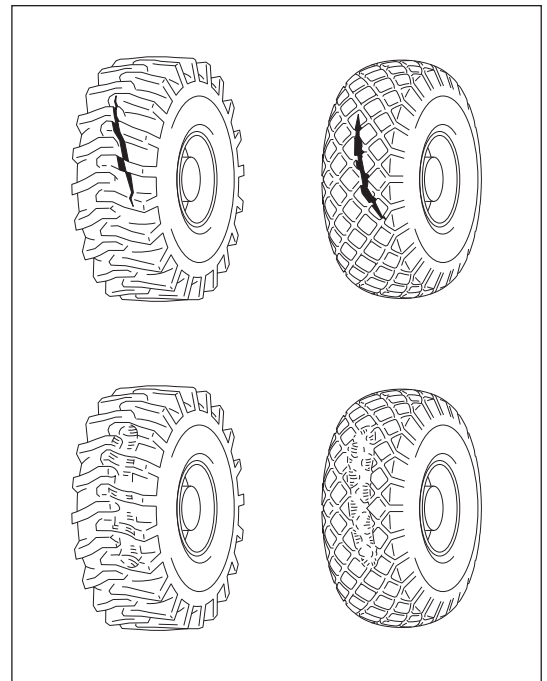

⑳ **Fuel tank**

- 1) With the drain plug removed, remove the water and sediment from the bottom of the tank.
- 2) If sedimentation is substantial, remove the drain plug and clean the interior of the tank.
- 3) When the necessary work and refueling are complete, tighten the filler cap positively.

**NOTE:** When removing the water and sediment from the tank filled with the fuel, the fuel will gush out if the drain plug is screwed out completely.

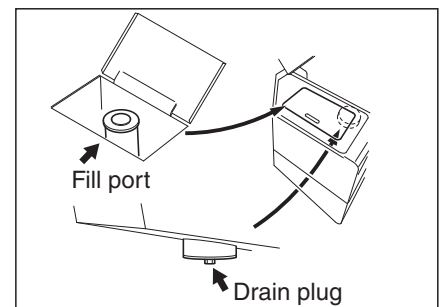

**⚠ WARNING**

- The fuel will catch fire if open flames or ignition sources are used close to it.
- Do not smoke or use a match or cigarette lighter close to it.



**Roll**

The roll may be worn deeply and broken depending on the operation method and the condition of the site. Check the roll occasionally in the same way as tires.

### 3. PERIODIC MAINTENANCE

## 3.5 Fluid and Lubricant Capacities

### (1) General rules

- 1) Never feed water or lubricant with the strainer removed.
- 2) Use recommended lubricant and hydraulic fluid.
- 3) Do not use lubricants and hydraulic fluid of different brands.
- 4) When replacing oil, drain it completely and clean the container with flushing oil before filling new oil.
- 5) When fueling SAKAI machines, be sure to use the fuel that we specify or recommend. Nonconformance resulting from use of fuel and lube oil other than those specified or recommended by our company is not covered by our warranty and repair service.

### (2) Capacity

Compartment	Type of fluid	Capacity in liters(gal.)
Fuel tank	Diesel oil	180 (48.0)
Engine oil pan	Engine oil	10.5 (2.8)
Hydraulic oil tank	Hydraulic oil	50 (13.2)
Wheel motor	Gear oil	3.2 (0.8)
Radiator	Coolant	13 (3.4)
Vibrator	Gear oil	21 (5.5)
Differential	Gear oil	7.3 (1.9)
Final drives	Gear oil	1.25 x 2 (0.33 x 2)

### (3) Rating

Lubricant	Service classification	Ambient temp. and applicable viscosity rating			Applicable standards
		-15 ~ 30°C (5 ~ 86°F) Cold	0 ~ 40°C (32 ~ 104°F) Moderate	15 ~ 55°C (59 ~ 131°F) Tropical	
Engine oil	API grade CH-4	SAE 15W-40	SAE 40	SAE 40	MIL-L-2104B
Gear oil	API grade GL4	SAE 80W-90	SAE 90	SAE 140	MIL-L-2105
Hydraulic oil	Wear resistant	ISO-VG32 over VI 140	ISO-VG46 over VI 140	ISO-VG68 over VI 110	ISO-3448
Grease	Lithium type extreme pressure				NLGI-2
Fuel	Diesel oil				ASTM D975-2D



**(4) Recommended lubricants**

Oil company \ Lubricant	Engine oil API – CF– 4	Gear oil API GL 4	Hydraulic oil VG 46	Grease (NLGI – II)
CALTEX	—	Universal Thuban 90	Rando Oil HD 46	Martifack EP 2
BP	Vanellus C Extra	BP Gear Oil EP 90	BP Energol HLP 46	BP Energrease LS – EP 2
ESSO	—	Esso Gear Oil GP 90	Nuto H 46	Beacon EP 2
MOBIL	Delvac MX	Mobil Pegasus Gear Oil 90	Nuto Oil 25	Beacon EP 25
SHELL	Rimula X	Shell Spirax 90 EP	Shell Tellus Oil 46	Shell Alvania EP Grease 2
CASTROL	Castrol GTX	Castrol Hypoy 90	Hyspin AWS 46	Spherrol ELP 2

- CAUTION:** 1) Fill the fluid reservoirs with the filters installed.  
2) Use recommended fuels and lubricants only.



### 3.7 Fuse box

The fuse box houses five 15A-, five 20A- lined up with spares fitted for 15A-, and 20A- fuses. Use fuses of correct capacity. See page 25.

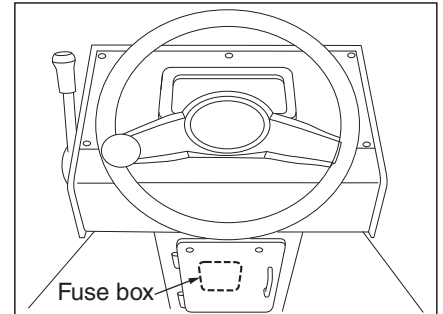

**NOTE:** When a fuse is burned, determine the cause before replacing.

### 3.8 Battery

- 1) Leaving the battery unused for long without attention or using its power excessively at a time can cause damage to the plates, leading to a shortened life.
- 2) For long-term storage, charge it fully, store in a cool and dry place, and check the level of charge at least once a month.
- 3) Maintain the level of charge above 75%.
- 4) In cold weather, it is desirable to start the engine with the battery charged 100%. Do not try to start the engine with less than 75%.

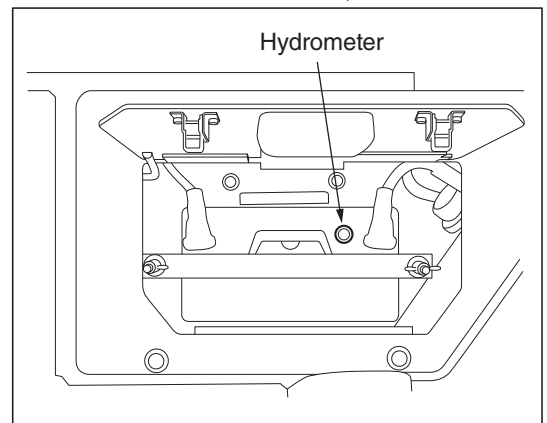
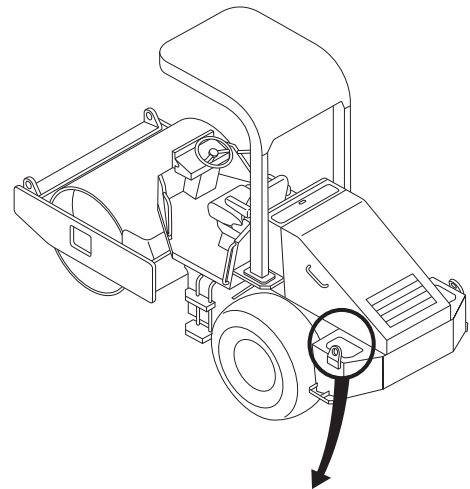

## 4. SPECIFICATIONS

### 4. SPECIFICATIONS

#### (1) SV400D-2

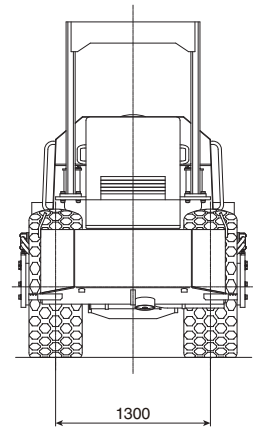
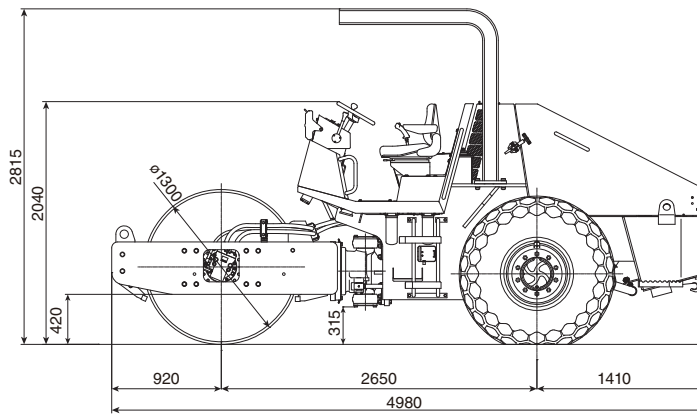
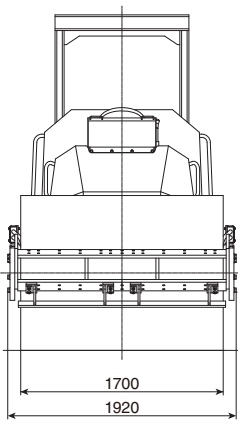
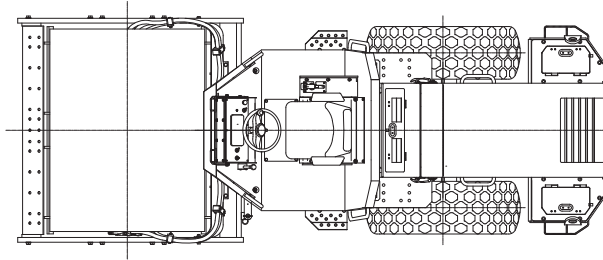

Model		SV400D-2	
<b>Weight:</b>			
Gross weight	7,430 kg (16,380 lbs)		
On front axle	3,630 kg (8,000 lbs)		
On rear axle	3,800 kg (8,380 lbs)		
<b>Dimension:</b>			
Overall length	4,980 mm (196")		
Overall width	1,920 mm (76")		
Overall height	2,815 mm (111")		
Wheelbase	2,650 mm (104")		
Wheel			
Front	Roll (dia. x width)		
	1,300 x 1,700 mm (51" x 67")		
Rear	Tire		
	16.9-24-6PR		
<b>Performance:</b>			
Travel speed			
	Low 0 ~ 6 km/h (0 ~ 3.7 mile/h)		
	High 0 ~ 10 km/h (0 ~ 6.2 mile/h)		
<b>Vibrating power:</b>			
	Low	High	
Frequency	38 Hz {2,300 vpm}	30 Hz {1,800 vpm}	
Centrifugal force	93 kN(20,945 lbs) {9,500 kgf}	118 kN(26,460 lbs) {12,000 kgf}	
Gradability	62% (32°)		
Rolling width	1,700 mm (67")		
Minimum turning radius	4.9 m (193")		
<b>Engine:</b>			
Model	DEUTZ "TCD2011L04W" Diesel Engine with turbo charger		
Total displacement	3.619 litres (221 cu.in) {3,619 cc}		
Rated output	74.9kW {102 ps}/2,300 min <sup>-1</sup> {rpm} (100 HP/2,300 rpm)		
Max. torque	350N·m {35.7 kgf·m}/1,600 min <sup>-1</sup> {rpm} (258 lb-ft / 1,600 rpm)		
<b>Tank capacity:</b>			
Fuel tank	180 litres (48 gal)		
Hydraulic oil tank	50 litres (13 gal)		

**NOTE:** Gradability is the calculated value. It may vary with ground surface conditions.

(2) SV400T-2

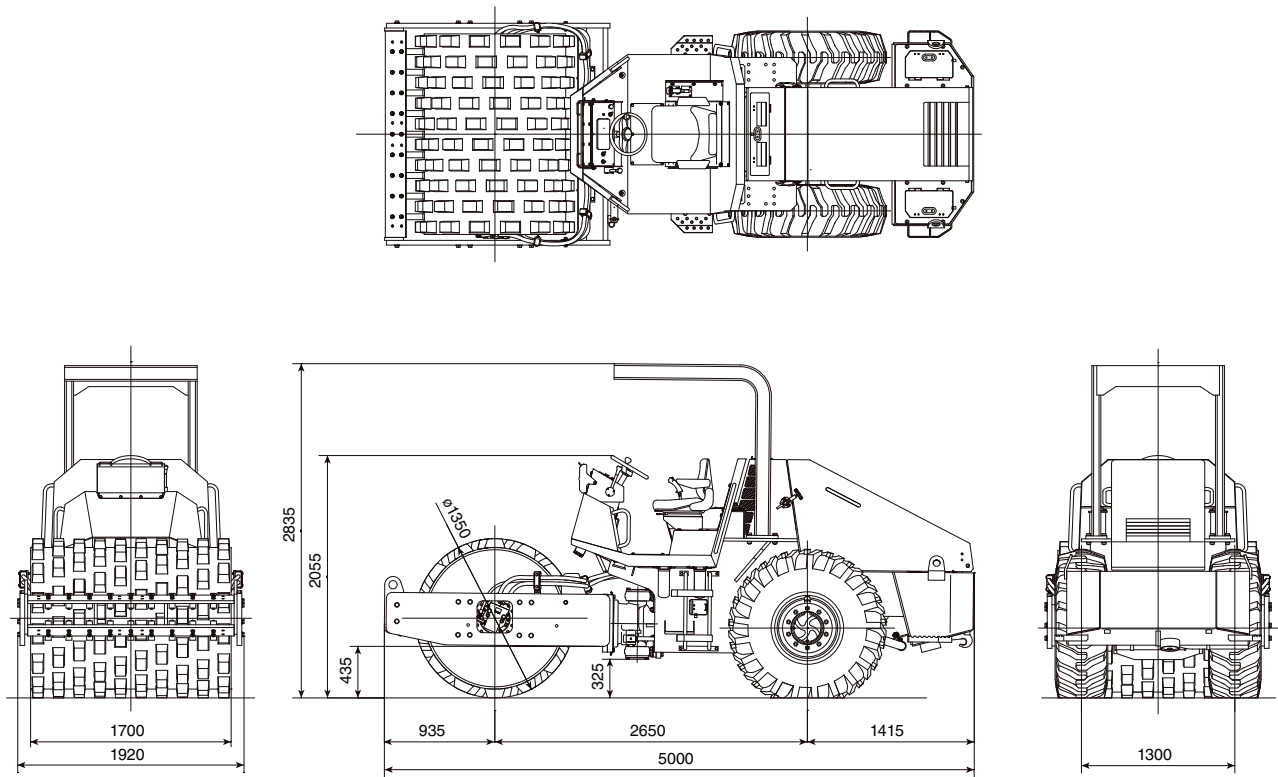

<b>Model</b>	<b>SV400T-2</b>		<b>Vibrating power:</b>	Low	High
<b>Weight:</b>			Frequency	38 Hz {2,300 vpm}	30 Hz {1,800 vpm}
Gross weight	7,650 kg (16,865 lbs)		Centrifugal force	103 kN(23,150 lbs) {10,500 kgf}	127 kN(28,660 lbs) {13,000 kgf}
On front axle	3,880 kg ( 8,555 lbs)		Gradability	62% (32° )	
On rear axle	3,770 kg ( 8,310 lbs)		Rolling width	1,700 mm (67")	
<b>Dimension:</b>			Minimum turning radius	4.9 m (193")	
Overall length	5,000 mm (197")		<b>Engine:</b>		
Overall width	1,920 mm ( 76")		Model	DEUTZ "TCD2011L04W" Diesel Engine with turbo charger	
Overall height	2,835 mm (112")		Total displacement	3.619 litres (221 cu.in) {3,619 cc}	
Wheelbase	2,650 mm (104")		Rated output	74.9kW {102 ps}/2,300 min <sup>-1</sup> {rpm} (100 HP/2,300 rpm)	
Wheel			Max. torque	350N·m {35.7 kgf·m}/1,600 min <sup>-1</sup> {rpm} (258 lb-ft / 1,600 rpm)	
Front	Roll (dia. x width) 1,350 x 1,700 mm (53" x 67")		<b>Tank capacity:</b>		
Rear	Tire 16.9-24-6PR		Fuel tank	180 litres (48 gal)	
<b>Performance:</b>			Hydraulic oil tank	50 litres (13 gal)	
Travel speed					
	Low	0~ 6 km/h ( 0~ 3.7 mile/h)			
	High	0~ 10 km/h ( 0~ 6.2 mile/h)			

**NOTE:** Gradability is the calculated value. It may vary with ground surface conditions.

## 4. SPECIFICATIONS

### (3) SV400TF-2

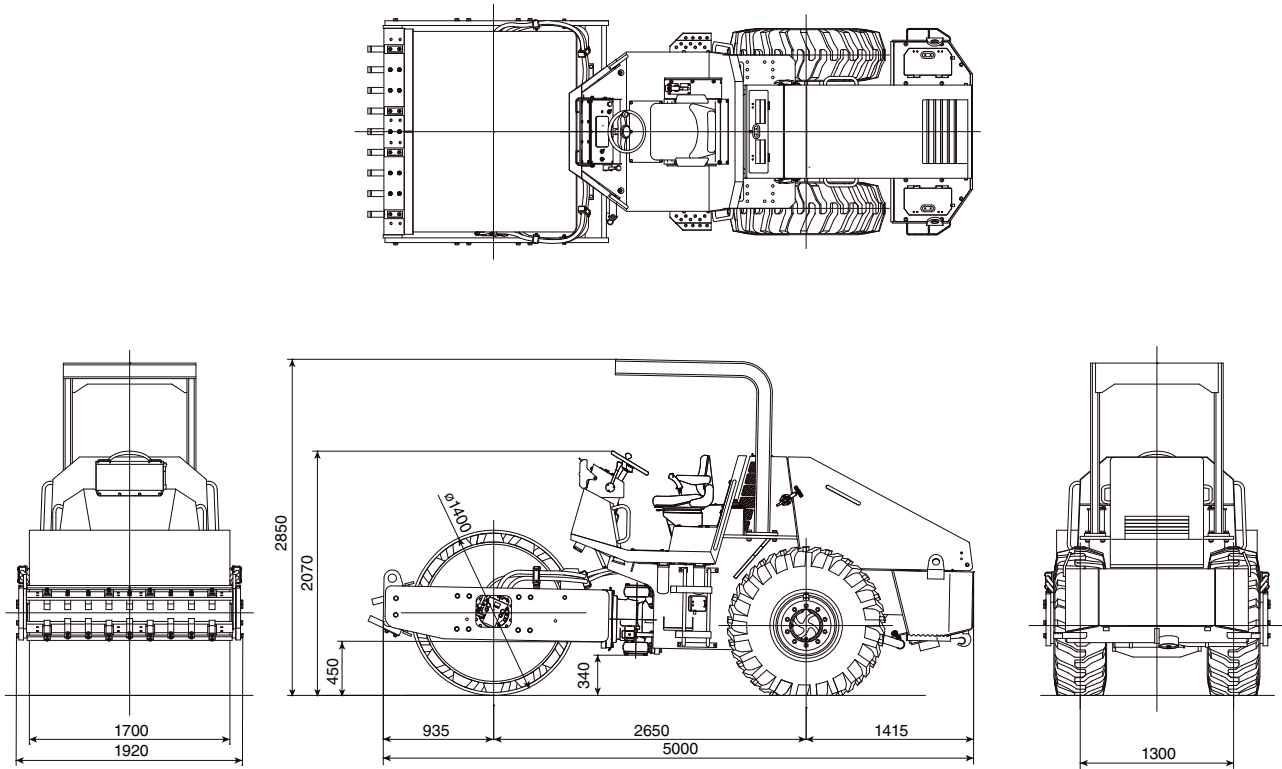

Model		SV400TF-2	
<b>Weight:</b>			
Gross weight	8,840 kg (19,490 lbs)		
On front axle	5,110 kg (11,265 lbs)		
On rear axle	3,730 kg (8,225 lbs)		
<b>Dimension:</b>			
Overall length	5,000 mm (197")		
Overall width	1,920 mm (76")		
Overall height	2,850 mm (112")		
Wheelbase	2,650 mm (104")		
Wheel			
Front	Roll (dia. x width)		
Smooth	1,400 x 1,700 mm (55" x 67")		
Pad	1,350 x 1,700 mm (53" x 67")		
Rear	Tire		
	16.9-24-6PR		
<b>Performance:</b>			
Travel speed			
	Low	0 ~ 6 km/h (0 ~ 3.7 mile/h)	
	High	0 ~ 10 km/h (0 ~ 6.2 mile/h)	
<b>Vibrating power:</b>			
	Low		High
Frequency	38 Hz {2,300 vpm}		30 Hz {1,800 vpm}
Centrifugal force	103 kN(23,150 lbs) {10,500 kgf}		127 kN(28,660 lbs) {13,000 kgf}
Gradability		50% (26°)	
Rolling width		1,700 mm (67")	
Minimum turning radius		4.9 m (193")	
<b>Engine:</b>			
Model	DEUTZ "TCD2011L04W" Diesel Engine with turbo charger		
Total displacement	3.619 litres (221 cu.in) {3,619 cc}		
Rated output	74.9kW {102 ps} / 2,300 min <sup>-1</sup> {rpm} (100 HP/2,300 rpm)		
Max. torque	350N·m {35.7 kgf·m} / 1,600 min <sup>-1</sup> {rpm} (258 lb-ft / 1,600 rpm)		
<b>Tank capacity:</b>			
Fuel tank	180 litres (48 gal)		
Hydraulic oil tank	50 litres (13 gal)		

**NOTE:** Gradability is the calculated value. It may vary with ground surface conditions.

(4) SV400TB-2

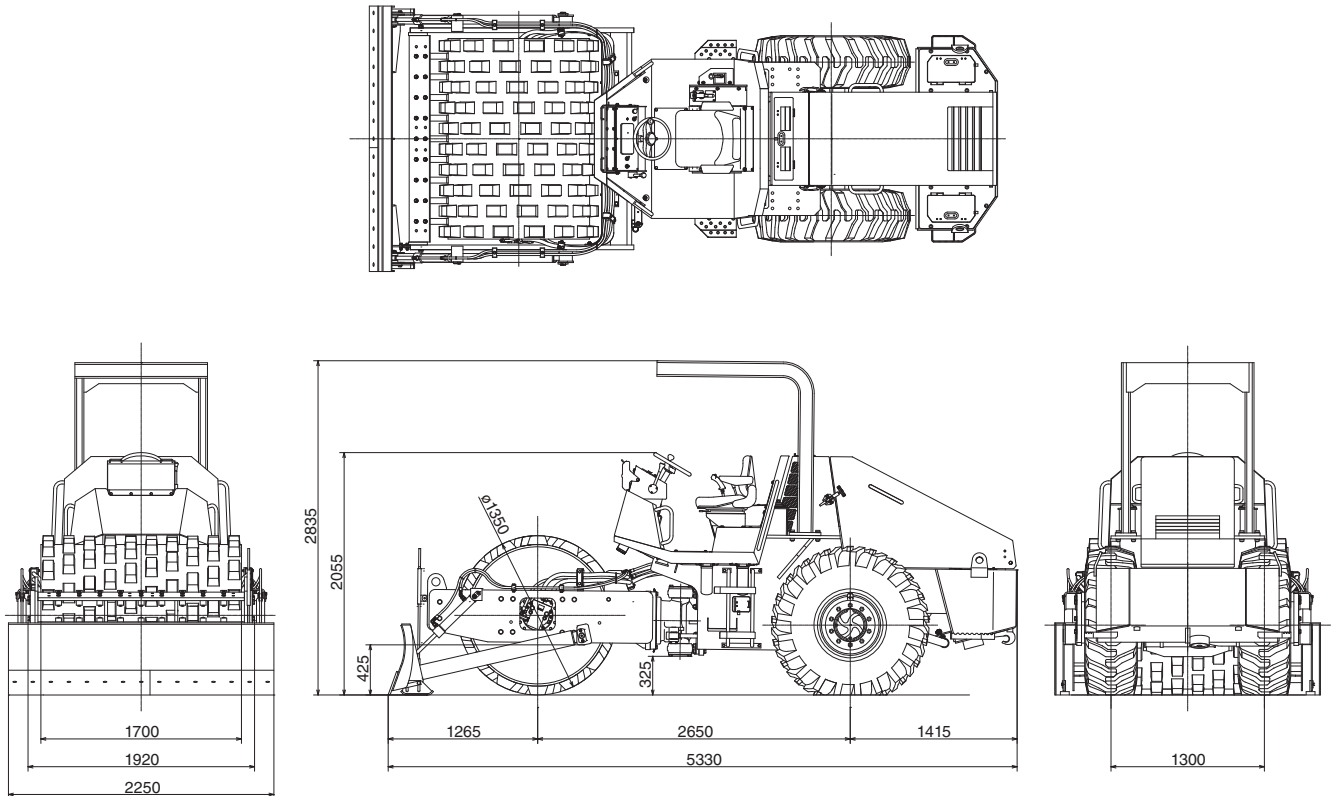

<b>Model</b>	<b>SV400TB-2</b>		<b>Vibrating power:</b>	Low	High
<b>Weight:</b>			Frequency	38 Hz {2,300 vpm}	30 Hz {1,800 vpm}
Gross weight	8,050 kg (17,745 lbs)		Centrifugal force	103 kN(23,150 lbs) {10,500 kgf}	127 kN(28,660 lbs) {13,000 kgf}
On front axle	4,380 kg ( 9,655 lbs)		Gradability	59% (30°)	
On rear axle	3,670 kg ( 8,090 lbs)		Rolling width	1,700 mm (67")	
<b>Dimension:</b>			Minimum turning radius	4.9 m (193")	
Overall length	5,330 mm (210")		<b>Engine:</b>		
Overall width	2,250 mm ( 89")		Model	DEUTZ "TCD2011L04W" Diesel Engine with turbo charger	
Overall height	2,835 mm (112")		Total displacement	3.619 litres (221 cu.in) {3,619 cc}	
Wheelbase	2,650 mm (104")		Rated output	74.9kW {102 ps}/2,300 min <sup>-1</sup> {rpm} (100 HP/2,300 rpm)	
Wheel			Max. torque	350N·m {35.7 kgf·m}/1,600 min <sup>-1</sup> {rpm} (258 lb-ft / 1,600 rpm)	
Front	Roll (dia. x width) 1,350 x 1,700 mm (53" x 67")		<b>Tank capacity:</b>		
Rear	Tire 16.9-24-6PR		Fuel tank	180 litres (48 gal)	
<b>Performance:</b>			Hydraulic oil tank	50 litres (13 gal)	
Travel speed					
	Low	0~ 6 km/h ( 0~ 3.7 mile/h)			
	High	0~ 10 km/h ( 0~ 6.2 mile/h)			

**NOTE:** Gradability is the calculated value. It may vary with ground surface conditions.

## 4. SPECIFICATIONS

### (5) SV400FB-2

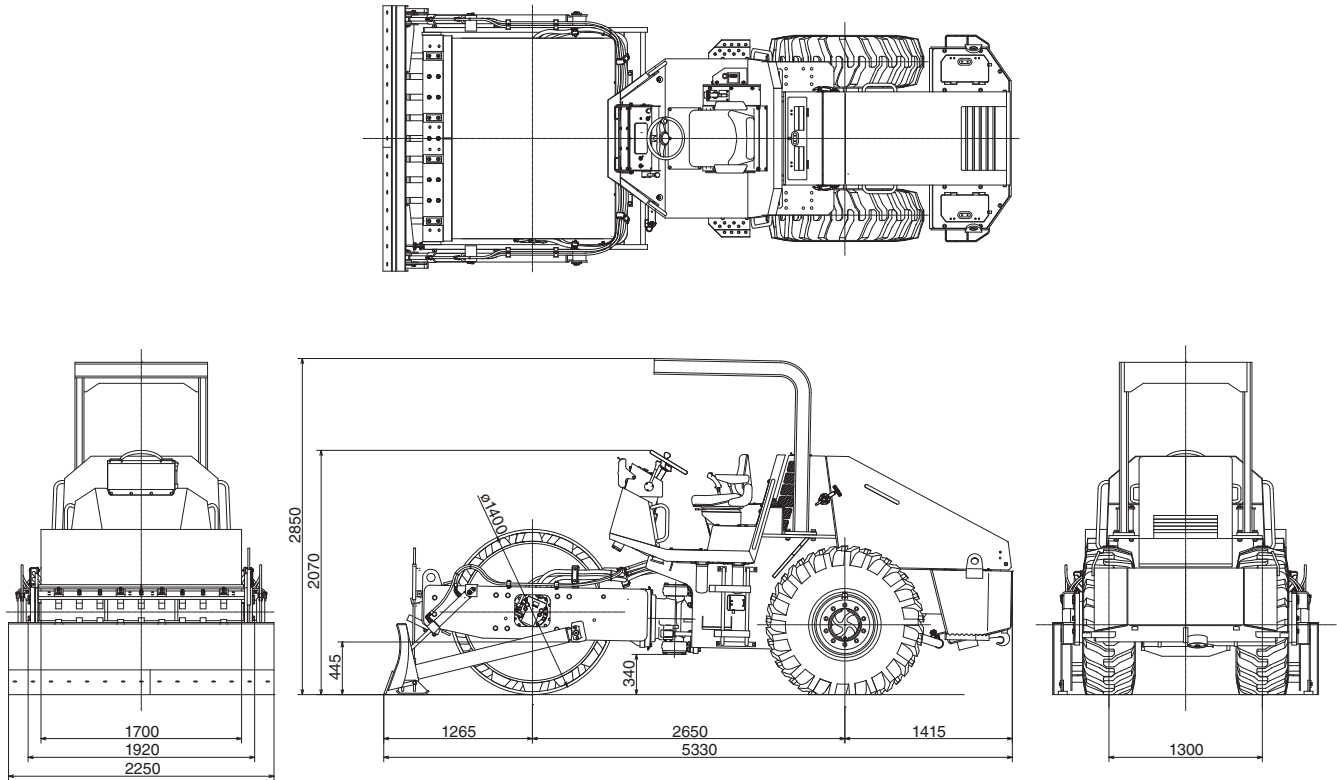

Model		SV400FB-2	
<b>Weight:</b>			
Gross weight	9,250 kg (20,390 lbs)		
On front axle	5,630 kg (12,410 lbs)		
On rear axle	3,620 kg (7,980 lbs)		
<b>Dimension:</b>			
Overall length	5,330 mm (210")		
Overall width	2,250 mm (89")		
Overall height	2,850 mm (112")		
Wheelbase	2,650 mm (104")		
Wheel			
Front	Roll (dia. x width)		
Smooth	1,400 x 1,700 mm (55" x 67")		
Pad	1,350 x 1,700 mm (53" x 67")		
Rear	Tire		
	16.9-24-6PR		
<b>Performance:</b>			
Travel speed			
	Low	0 ~ 6 km/h (0 ~ 3.7 mile/h)	
	High	0 ~ 10 km/h (0 ~ 6.2 mile/h)	
<b>Vibrating power:</b>			
	Low	High	
Frequency	38 Hz {2,300 vpm}	30 Hz {1,800 vpm}	
Centrifugal force	103 kN(23,150 lbs) {10,500 kgf}	127 kN(28,660 lbs) {13,000 kgf}	
Gradability	48% (25°)		
Rolling width	1,700 mm (67")		
Minimum turning radius	4.9 m (193")		
<b>Engine:</b>			
Model	DEUTZ "TCD2011L04W" Diesel Engine with turbo charger		
Total displacement	3.619 litres (221 cu.in) {3,619 cc}		
Rated output	74.9kW {102 ps} / 2,300 min <sup>-1</sup> {rpm} (100 HP/2,300 rpm)		
Max. torque	350N·m {35.7 kgf·m} / 1,600 min <sup>-1</sup> {rpm} (258 lb-ft / 1,600 rpm)		
<b>Tank capacity:</b>			
Fuel tank	180 litres (48 gal)		
Hydraulic oil tank	50 litres (13 gal)		

**NOTE:** Gradability is the calculated value. It may vary with ground surface conditions.



**SAKAI HEAVY INDUSTRIES, LTD.**

Head Office: 1-4-8, Shiba Daimon, Minato-ku,  
Tokyo, Japan

Telephone: Tokyo (03) 3431-9971

Facsimile: (03) 3436-6212