

PREFACE

This operator's manual serves as a guide for the use of your Sakai SV510-III Series Vibrating Roller for those who are new to the machine, and also for the people who have experience in using the Machine and want to refresh their knowledge for the machine.

Read this manual thoroughly and try to fully understand the information before operating your machine. Keep this handbook at hand whenever you do your work.

The main subjects of this manual are:

(1) Basic precautions for safety, (2) Operation, (3) Daily maintenance and (4) Specifications. For operation and maintenance of the engine, refer to the Engine Instruction Manual furnished separately. Descriptions in this manual can differ from the machine instructions of your machine due to the results of the investigation and improvement in its design. If you have any inquiry regarding your Machine or this manual, contact our distributors.

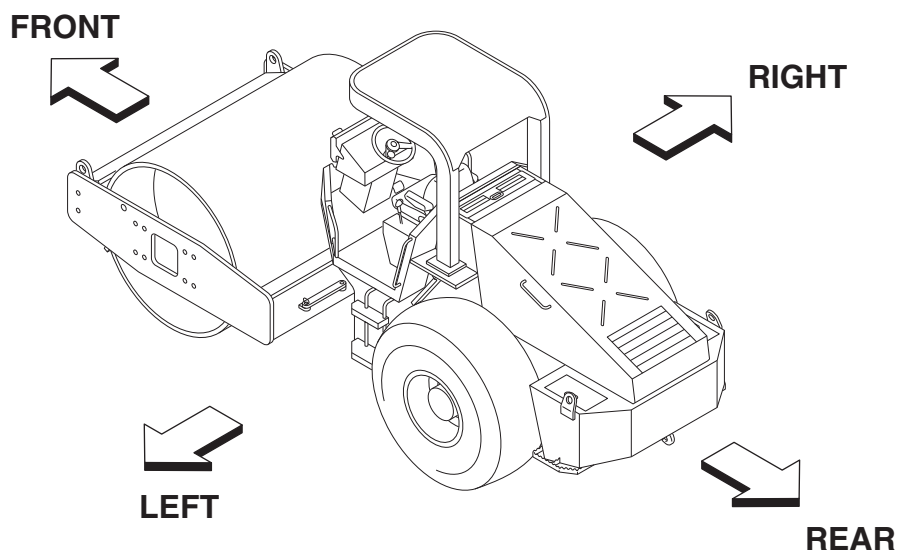

CONTENTS

PREFACE

MACHINE AND ENGINE IDENTIFICATION NUMBERS	1
SAFETY NOTICES.....	2

1 BASIC PRECAUTIONS FOR SAFETY	4
1.1 General Precautions	4
1.2 Preparation for Safe Operation	6
1.3 Before Starting the Engine.....	7
1.4 After Starting the Engine.....	8
1.5 During operation	8
1.6 Loading and Unloading.....	10
1.7 Transportation.....	11
1.8 Handling the Battery	11
1.9 Towing.....	12
1.10 Before Servicing	13
1.11 During Servicing	14
1.12 Safety Decals.....	16
2 OPERATION.....	18
2.1 Instruments and Controls.....	18
2.1.1 Operator's station	18
2.1.2 Gauges, indicator lamps and warning lamps	19
2.1.3 Switches.....	22
2.1.4 Operating levers / pedals	24
2.1.5 Unloader valve	25
2.1.6 Fuse box.....	26
2.2 Handling and Adjustments	26
2.2.1 Seat adjustment	26
2.2.2 Scraper adjustment and replacement	26
2.2.3 Disengaging the brake when towing	27
2.2.4 Handling of Diagnostics On / Off switch and Increment / Set-Decrement / Resume switch.....	28
2.3 Operation	29
2.3.1 Before-starting inspection	29
2.3.2 Starting the engine.....	30
2.3.3 After starting the engine	31
2.3.4 Traveling.....	32
2.3.5 Stopping / Parking.....	33
2.3.6 Stopping the engine	34
2.3.7 Check after stopping the engine.....	34
2.4 Vibratory Operation.....	35

2.5	Precautions for Work.....	36
2.5.1	Compaction operation.....	36
2.5.2	When going downhill.....	36
2.5.3	On a slope.....	36
2.6	Applicable Jobs.....	36
2.7	After Operation.....	37
2.8	Loading and Unloading.....	38
2.8.1	Use of a trailer equipped with a winch.....	38
2.8.2	Self-propelling.....	39
2.9	After Loading the Machine.....	40
2.10	Transportation.....	40
2.11	Operation in Cold Weather.....	40
2.11.1	Fuel oil and grease.....	40
2.11.2	Coolant.....	41
2.11.3	Battery.....	42
2.12	When the Cold Season is Over.....	43
2.13	For a Long Storage Period.....	43
2.14	During the Storage Period.....	43
2.15	When the Battery Has Discharged.....	44
2.15.1	Connection and disconnection of booster cables.....	44
3	PERIODICAL MAINTENANCE.....	46
3.1	Precautions.....	46
3.1.1	Lifting the machine on a hoist.....	48
3.2	Walk-around Checking.....	49
3.3	Periodical Maintenance Points.....	50
3.4	Maintenance Procedure.....	52
(1)	Every 10 hours or daily.....	52
(2)	Every 50 hours.....	53
(3)	Every 250 hours.....	54
(4)	Every 500 hours.....	57
(5)	Every 1000 hours.....	59
(6)	As required.....	61
3.5	Feeding Water and Lubricants.....	63
3.6	Electric Wiring Diagram.....	65
4	SPECIFICATIONS.....	67



MACHINE AND ENGINE IDENTIFICATION NUMBERS

When ordering parts or making inquiries about your machine, the following information is requested:

(1) Machine model

Indicated on the nameplate of the right side of the operator's seat.

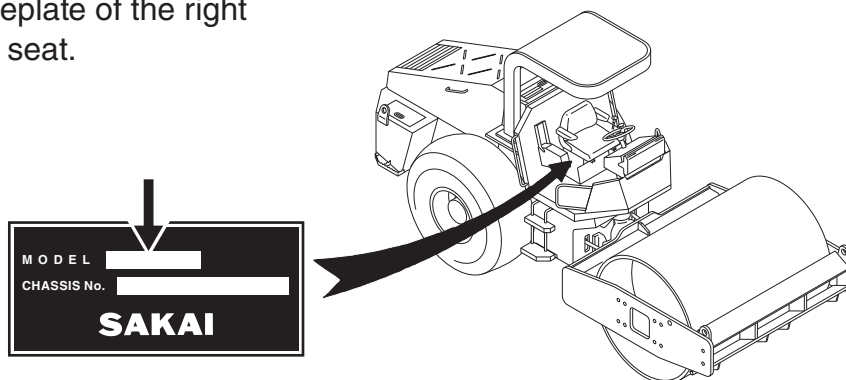

(2) Machine serial number

SV510D-III ⇨ VSV21 - ○○○○○○
 SV510T-III ⇨ VSV21 - ○○○○○○
 SV510TF-III ⇨ VSV21 - ○○○○○○

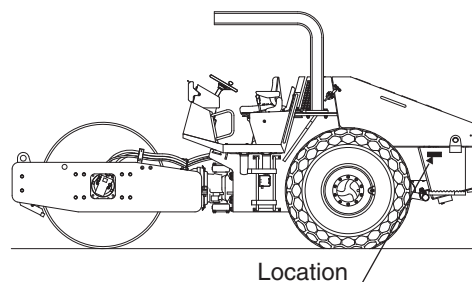

(3) Engine serial number

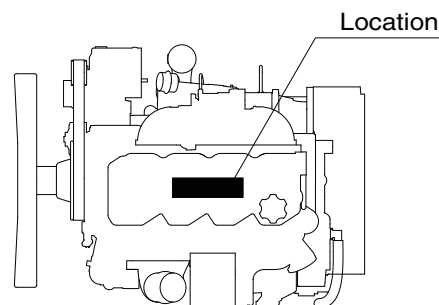







SAFETY NOTICES

For the safe use of your machine, correct handling and periodical maintenance are of utmost importance. Thoroughly read the safety precautions described in this manual. Do not attempt to operate and maintain your machine until you gain a full understanding of these safety statements.

This manual covers the proper and safe method of driving and handling of this machine for its intended use. When this machine is used a manner, other than that covered in this manual, you must assume responsibility for your own personal safety.

In this manual and on the machine, you will find safety notices. Each safety notice starts with a signal word as shown below:

- | | |
|--|---|
|  DANGER | Denotes that there is an extreme hazard. If you fail to take proper precautions, it is highly likely that you could be killed or seriously injured (The color of the symbol  is red). |
|  WARNING | Denotes that there is a hazard. If you fail to take proper precautions, you could be killed or seriously injured (Symbol  is orange). |
|  CAUTION | Calls attention to safety practices. If you fail to take proper precautions, you could be injured or cause damage to the machine (Symbol  is yellow). |

It is almost impossible for the safety notices in this manual and or the machine to cover all the potential dangers. Keep alert to possible dangers not mentioned in this manual and on the decal.

⚠ WARNING

Do not operate your machine before you read its operator's manual thoroughly.

Incorrect operation can kill or cause injury.

It is your responsibility to operate the machine safely.

- ☆ Non-approved modifications can pose safety-related problems. Before making any modifications, consult your distributor. For an injury or damage to the machine caused by non-approved modifications, Sakai accepts no responsibility.
- ☆ Basic precautions for safe operation of your machine are discussed beginning on page 4.
- ☆ To operate and work with your machine, you must be qualified.

⚠ WARNING: Negligence of these instructions can lead to accidents.

1. BASIC SAFETY PRECAUTIONS

1 BASIC PRECAUTIONS FOR SAFETY

1.1 General Precautions

■ Read thoroughly the operator's manual

- Understand the functions of the controls and gauges. Familiarize yourself with their location and how to operate them. Understand the meaning of all the symbols.



■ Obey the worksite rules

- Follow the worksite rules such as matters forbidden or to be attended to, and working procedures.

■ Wear protective clothing to suit the work

- Wear clothing, safety shoes and hard hat to suit your work.
- Do not wear clothing and accessories that tend to get caught in the controls or protruded portions of the machine. Do not wear oily clothing.
- According to the type of jobs, wear safety goggles or mask.



■ Know the work area in advance

- Know the terrain, geology and conditions of the road surface at the worksite. Start working after securing safety such as stationing a guardsman or putting up barriers where there is a risk of falling of the machine or collapse of shoulder.

■ Provide against an accident

- Decide in advance the means of communication in an emergency. Know the location and use of an extinguisher and first-aid kit.

■ Know the capability of the machine

- Thoroughly understand the performance of your machine and correctly operate the machine to meet the requirements of the job site. Operating the machine beyond its capabilities may lead to an accident. Use your machine within its capability.



⚠ WARNING: Negligence of these instructions can lead to accidents.

1. BASIC SAFETY PRECAUTIONS

■ Do not use a machine which has not been serviced correctly at regular intervals

- Before working, perform necessary inspections. Start operation only after making certain the machine is in good operating condition. If found to be abnormal, report to the responsible person and have the fault corrected. Operate the machine after making sure that it is safe to operate.

■ Do not allow anyone to enter the work area except for authorized personnel

- Always conduct the work paying attention to the workers around the machine.



■ Be careful of hot parts

- After your machine has operated for some time, the coolant, engine oil and hydraulic fluid will become hot and the pressure will build up. If, in this state, you try to remove the filler caps, drain the oil or replace the filters, you can get burned. Perform this work in accordance with the correct procedures with the machine cooled down.
- To remove the radiator cap, slowly loosen the cap to relieve the pressure with the engine shut down and the coolant cooled down. (For the radiator cap with a lever, lift the lever to release the trapped pressure.)
- When removing the filler cap on the hydraulic tank, release the trapped pressure by turning it out slowly to prevent the oil from gushing out.
- Do not touch the muffler while the engine is running or immediately after it has been shut down. You can get burned.



■ Be careful with fire

- The fuel, oil, and anti-freeze will catch fire if open flames or ignition sources are used close to them. Particularly, the fuel is highly flammable.



- Do not smoke or use a match or cigarette lighter close to inflammables (combustibles).
- When refueling, stop the engine and do not smoke.
- The filler caps of the fuel and oil tanks must be kept tight.





⚠ WARNING: Negligence of these instructions can lead to accidents.

1. BASIC SAFETY PRECAUTIONS

■ Mount on or dismount from your machine after it has come to a complete stop

- For getting on and off, face the machine and use the handrail and step.
- Do not jump on or off a machine, particularly when it is moving.

■ To handle the hydraulic fluid

- Wear safety goggles to protect your eyes from contact with hydraulic fluid. It can irritate your eyes.
If the fluid contacts your eyes, flush with clean water for 15 minutes and get medical aid.
- The fluid can also irritate your skin. When handling it, wear rubber gloves to avoid contact with it. In case of skin contact, wash with soap and water.
- Be careful not to swallow the fluid. It can cause diarrhea and emesis.
If swallowed, do not try to vomit. Get medical help immediately.



1.2 Preparation for Safe Operation

■ Clean the step, operator's station and floor board

- Do not place parts, tools or unnecessary articles on the step, operator's station and floor board.
- Keep the step, floor board, controls and handholds free from muds, oil, ice or water, as they can cause slippage. Repair them if found to be damaged. Tighten loose bolts.
- Keep your boot soles free of oil or muds. They can slip, leading to an accident.

■ Inspect your machine before operation

- Check your machine for damage such as cracks and deformation. If found to be abnormal, operate the machine after taking a proper measure to secure safety.
- Check the level of fluids (fuel, engine oil, coolant, anti-freeze and hydraulic oil). Add as necessary.
- Check the area where the machine has parked for signs of leakage of oil, fuel and water. If any leakage is noticeable, determine the cause and make corrections immediately.





⚠ WARNING: Negligence of these instructions can lead to accidents.

1. BASIC SAFETY PRECAUTIONS

■ Know the stopping distance

- When traveling on a road, bear in mind the stopping distance. Avoid excessive speed, and abrupt starting and stopping, and moving in a zigzag direction.

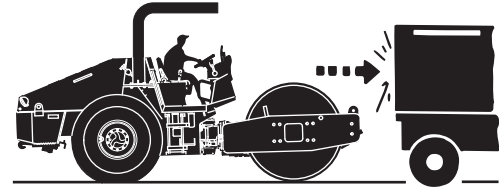

1.3 Before Starting the Engine

■ Adjust the operator's seat to your most effective operating position

- Sit on the operator's seat. Adjust the seat so that your back will make contact with the seat back when the brake pedal is depressed to the full extent. Check to be sure that the brake pedal can be fully depressed without difficulty when you twist your body for reverse run.

■ Secure good visibility (with cabin)

- Keep the windowpane clean.
- Lock the windows and doors no matter whether they are open or closed.
- Do not leave the doors half-closed.

■ Secure forward and backward visibilities

- Adjust the rear view mirrors and under mirrors for good visibility. If dirty, clean them. If damaged, replace.

■ Check that the horn, lamps and gauges work correctly

■ Before starting, make certain that each lever is in the neutral position and the parking brake is applied

■ When starting, sound the horn

- Before starting the engine. Make sure there is no one in the immediate vicinity and there are no obstructions around the machine.



⚠ WARNING: Negligence of these instructions can lead to accidents.

1. BASIC SAFETY PRECAUTIONS

■ Pay attention to ventilation

- Exhaust fumes are dangerous if breathed in. When starting the engine in an enclosed area, provide good ventilation with windows and doors opened.



■ Do not stand close to the exhaust gas pipe opening

- Exhaust fumes are noxious if breathed in.

1.4 After Starting the Engine

■ Secure safety around the machine

- Ensure that the area around the machine is clear of personnel and obstructions. Pay particular attention to dead spaces. Before starting, sound the horn.



■ Warm up the Engine

- Do not put your machine into motion immediately after the engine has started, let it idle for several minutes until it is at operating temperature.
- Check the area where the machine has parked for signs of leakage or oil, fuel and water. If any leakage is noticeable, determine the cause and make corrections immediately.

■ Have a trial run

- Make a test run in a safe place to check that there are no abnormal signs. If found to be abnormal, rectify the fault before traveling again.
- Listen for unusual sounds, and check for abnormal temperature rise. If abnormal, park the machine in a safe location and find the source of trouble before operating.

1.5 During Operation

■ No other person but the operator

- This machine is a one-man roller. Do not allow anyone to get on. Only the operator is allowed on this machine while it is running or in operation. Radios are not permitted.

■ Sit in the driver's seat before starting operation

- Sit in the driver's seat before starting operation. Be sure to wear the seat belt when provided.



⚠ WARNING: Negligence of these instructions can lead to accidents.

1. BASIC SAFETY PRECAUTIONS

■ Before mounting, be sure areas around the machine are safe

- Before getting on the machine, make certain that there are no obstacles around the machine and no workers under it. If some workers are present or close to the machine, tell them that the machine is about to move, warning them to stay away from it.

■ Do not try to get on or off a moving machine

- Get on or off the machine after making sure it has come to a complete stop.

■ To go uphill or downhill, run at low speeds. Do not attempt to shift speeds while traveling on a grade

- Shifting speeds on a slope can cause unexpected running down the slope.
- Going down hill at speeds other than low range can cause the machine to run down violently.

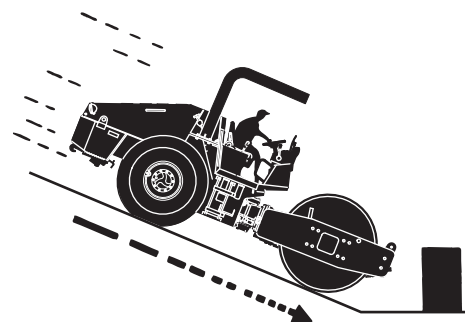

■ Refrain from inattentive driving

- Inattentive driving or driving relying on guess work can cause an accident. Use extreme care for workers present in the path of the roller or around it. In case of danger, stop and sound the horn, and proceed when the area is clear of personnel or obstructions.

■ When changing the direction of travel, secure the safety on the path in the travel direction

■ Keep everyone away from the pinch points

- When making turns, do not allow anyone to come close to the pinch point.

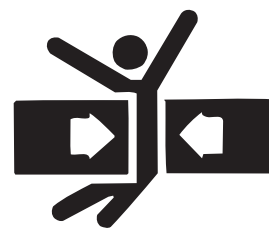

■ At night, carefully drive the machine

- Nighttime driving tends to frustrate the sense of distance. Carefully drive the machine at a speed suited to illumination. Keep the headlamps and flood lamps lighted. If necessary, provide extra lighting in the work area.

■ Repair as soon as possible if found to be defective

- If the machine is found to be faulty, stop the machine and repair. Do not operate the machine until the problem is corrected. When any warning lamp indicates faulty operation, inspect the machine after moving it to the nearest safe location.





⚠ WARNING: Negligence of these instructions can lead to accidents.

1. BASIC SAFETY PRECAUTIONS

- **Do not operate the machine except from the operator's seat. Do not drive in a standing posture**
- **While making turns, do not run at abnormally high speed and do not turn the steering wheel abruptly and sharply**
- **For the traveling on structures such as a bridge, make certain that they can support your machine. Before traveling on the structure, you must know the load capacity of the structure and the load weight of the machine you are operating to insure safe travel across the structure**
- **Do not make turns on a slope and do not travel across sidehill. If necessary to do so, go down straight along the slope to the flat ground, move sideways and go up straight to the destination**

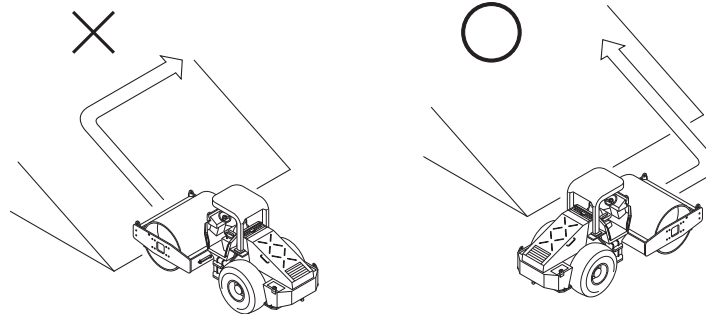

■ **When parking**

- Select level and hard ground. If necessary to park on a slope, block the front of the drums on the downside of the slope.
- When required to park on the public road, provide necessary markings such as flag, barriers and illumination. However, be sure they do not obstruct traffic.
- When getting off the machine, stop the engine and remove the key from the ignition switch.

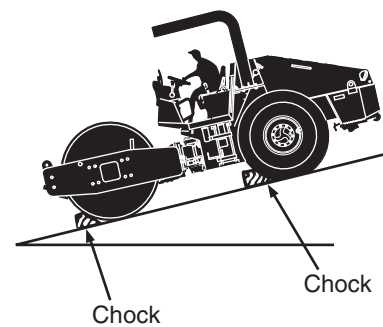

1.6 Loading and Unloading

- Loading and unloading can accompany any danger. Use extreme care.
- Select level and hard ground leaving a sufficient distance from the shoulder.
- Use sturdy ramps with proper width, length and thickness which allow safe loading and unloading. If they deflect considerably under load, apply wooden blocks to reinforce the ramps.

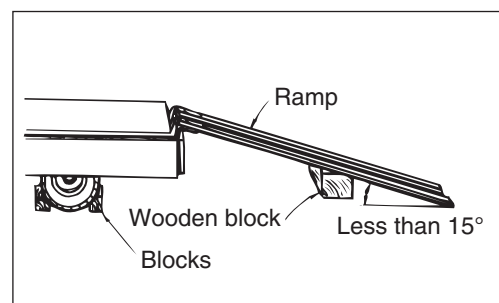

⚠ WARNING: Negligence of these instructions can lead to accidents.

1. BASIC SAFETY PRECAUTIONS

- To prevent your machine from crosswise slippage, keep the ramps free from oil, mud, debris, etc. The drum must also be free from extraneous matter that can cause slippage.
- Do not steer your machine on the ramps. If the machine is facing in the wrong direction, allow it to dismount from the ramps, correct the direction and try again.
- Do not use kinked, twisted or damaged wireropes for crane or winch operation. Use ones with ample strength.
- When loading is complete, fix the machine with wooden blocks placed under the drums and chains fastened to the machine.

1.7 Transportation

- Follow required regulations.
- Select a transporting route according to the overall width, overall height and gross weight of the trailer with the roller loaded.

1.8 Handling the Battery

■ When handling the battery

- Battery electrolyte contains sulphuric acid. It will destroy clothing and skin. If it touches your clothing or skin, flush with large quantities of water.
- In case of eye contact, flush with clean water and seek medical help.
- If swallowed, drink large amount of water, milk, beaten egg or vegetable oil, and get medical help.
- Wear safety goggles when handling the battery.
Wear safety goggles, full face shield, rubber gloves and rubber apron when adding fluids to the battery.
- The battery generates flammable gases that can cause an explosion. Do not smoke close to the battery. Keep the battery away from flames, sparks and ignition sources.



⚠ WARNING

Battery posts, terminals, and related accessories contain lead and lead compounds, chemicals known to the State of California to cause cancer and reproductive harm.

Wash hand after handling.



⚠ WARNING: Negligence of these instructions can lead to accidents.

1. BASIC SAFETY PRECAUTIONS

- Inspect or handle the battery with the engine shut down and the starter key in the OFF position.
- Keep metallic items such as tools away from the battery terminals.
- Loose terminals can cause sparks leading to an explosion. Secure the terminals tightly.

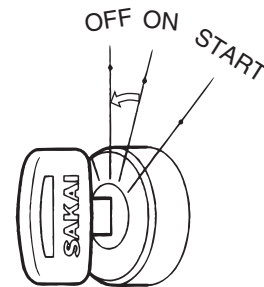

■ Jump-starting the engine

- Wear safety goggles when jump-starting the machine.
- When starting from another machine, do not allow the two machines to make contact with each other.
- When connecting the battery cables, start with the positive terminal. For disconnection, start with the negative one.
- Do not allow a tool to bridge between the positive terminal and machine body. This can generate dangerous sparks.
- Do not connect the booster cable to wrong terminal. Never connect the positive terminal to the negative.
- Final connection to the engine block of the disabled machine can cause sparks. The connecting point should be as far as possible from the battery.

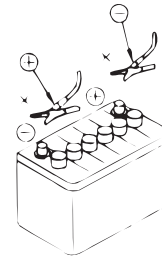

1.9 Towing

- To tow the machine, use wire ropes with ample strength.
- Do not perform towing on a slope.
- Do not use towing ropes twisted, kinked or damaged.
- Do not stride towing cables.
- Keep everyone away from the space between the machine and the towing vehicle when connecting the two.
- Align the connecting portions of the machine and towing vehicle straight when coupling the machine.



⚠ WARNING: Negligence of these instructions can lead to accidents.

1. BASIC SAFETY PRECAUTIONS

1.10 Before Servicing

■ Attach warning tags when servicing the machine

- Serious accidents can occur if the machine is unexpectedly started or controls carelessly touched by an unauthorized person.
- Attach a warning tag at a clearly visible location in the operator's station and insure the key has been removed from the ignition switch.



■ Use proper tools

- It is very dangerous to use damaged or deteriorated tools or to use tools for other purposes than intended. Use correct tools for their intended use only.



■ Change safety-related parts at regular intervals

- Replace fuel hose and high pressure hydraulic hoses regularly to prevent fire. Replace high pressure hoses of the power steering system every two years.
 - ☆ Change these parts at regular intervals even if found to be normal. They will deteriorate as time goes on.
 - ☆ Change any hose found to be abnormal even if it is within its recommended service interval.

■ Inspect or service your machine with the engine stopped

- If required to keep the engine running in such a case as radiator interior cleaning, perform the work with two persons. One of them should sit on the operator's seat getting ready for shutting down the engine. He must take care not to touch any of controls carelessly. Maintenance personnel must exercise extreme caution not to make contact with moving parts.

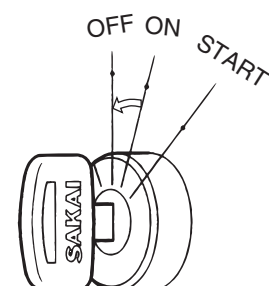

⚠ WARNING: Negligence of these instructions can lead to accidents.

1. BASIC SAFETY PRECAUTIONS

■ Supplying fuel and oils

- Spilled fuel or oil will be slippery. Wipe up immediately. Keep the filler caps tight. Do not use fuel for flushing oil. Handle fuel and oil in a well ventilated area.

■ Check the coolant level in the radiator

- To check the coolant level, shut down the engine and allow the engine and radiator to cool down.

■ Illumination

- For inspecting the level of the fuel, oil, coolant and battery electrolyte, use burn-proof illuminations. Failure to use this type of illumination can result in an explosion.



1.11 During servicing

■ Keep unauthorized persons away

- During service, do not allow persons not concerned to enter the work area, particularly when grinding or welding operation is performed or heavy hammers are being used.



■ Keep your machine clean

- Spilled oil, grease or scattered debris are dangerous. Always keep your machine clean. Moisture that penetrates into the electrical system can cause malfunctions. Do not use water to clean sensors, connectors and the operator's station.

■ When repairing the electrical system

- For repairing the electrical system or for conducting welding, disconnect the negative cable from the battery to shut off the electricity.



■ Carefully handle high pressure hoses

- Do not try to bend or hit hoses against a hard object. Do not use hoses or pipes that are bent or damaged. They will burst.
- Replace damaged fuel hose and hydraulic hoses. An oil or hydraulic fluid spill can cause a fire.

▲ WARNING: Negligence of these instructions can lead to accidents.

1. BASIC SAFETY PRECAUTIONS

■ Be careful of high pressure hydraulic fluid

- Bear in mind that the working equipment hydraulic systems are under internal pressure. Do not perform adding, draining, inspection or servicing of the hydraulic systems until the internal pressure has been relieved. Hydraulic fluid leaking through a fine hole at high pressure can penetrate your skin and eyes. Inspect leakage by holding a hard board close to suspected leaks wearing goggles. If affected by high pressure oil, get medical help immediately.

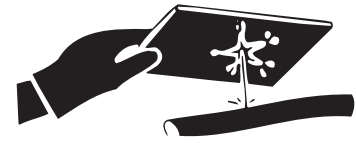

■ Be careful of hot parts

- After the machine has been operated for some time, the coolant, engine oil and hydraulic fluid will become hot.
- Removing the radiator cap or draining the coolant or oil can burn you. Perform this work in accordance with correct procedures after the systems have cooled down.



■ Use care when inspecting or servicing fan or belts in motion

- Secure loose clothing and keep articles away that could get caught in moving parts.
- Do not let your body or tools make contact with the fan blades or belts. They can be cut seriously.



■ Used oil disposal

- Do not throw used oil into a drain or waterway. Drain the oil from the machine into a proper container. Do not drain directly on the ground.
- Obey all local, state and federal environment regulations for the proper disposal of oil, fuel, coolant, battery electrolyte or any other fluids.

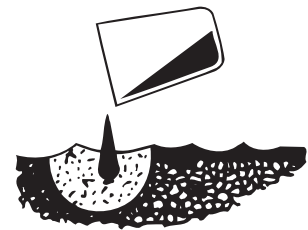

■ Exercise extreme care when replacing and repairing tires

- Disassembly, repair and reassembly of tires require special facility and knowledge. Have them repaired at work shop specialized in handling tires.
- Improperly fitted rim can separate if the tire is inflated. When inflating tires, do not work in front of the rim. Use correct inflation pressure.
- When dismounting a tire, chock other tires for safety.
- When welding job is carried out near the tires, use extreme care, as this can cause an explosion of the tires.





⚠ WARNING: Negligence of these instructions can lead to accidents.

1. BASIC SAFETY PRECAUTIONS

1.12 Safety Decals

Keep all decals clean. If lost, replace with new one. There are decals other than those shown below: Treat them in the same manner as the one shown here.

① 3998-16504-0

⚠ WARNING
<p>1. When Handling the Machine:</p> <ul style="list-style-type: none"> Operate only while seated. Use the handrails and steps when boarding and getting off. Never carry passengers. Never attempt to board or get off the machine while it is moving. <p>2. Preparation for Safe Operation</p> <ul style="list-style-type: none"> Clean the steps, operator's station and floorboards. Obey the worksite rules. Sakai accepts no responsibility for any injury or damage to the machine caused by unapproved modification. Do not use a machine which needs repair or maintenance. Sound the horn immediately prior to starting the engine to warn people in the vicinity. <p>3. Starting the Engine</p> <ul style="list-style-type: none"> Check that all operating levers are in the neutral position. Idle the engine for about 5 minutes to warm it up prior to commencing work. <p>4. Parking Precautions</p> <ul style="list-style-type: none"> When parking the machine, park it on level ground, set the parking switch and set the roller chocks. Allow the engine to cool off by running it for about 5 minutes before stopping. When getting off the machine, remove the key from the ignition switch.
<small>3998-16504-0</small>

⑤ 3998-16499-0 (2 locations)

⚠ WARNING
<ul style="list-style-type: none"> Do not open the hood with the engine running. Contact with hot parts will cause burns. Contact with rotating parts will cause severe injury.
<small>3998-16499-0</small>

⑩ 3998-16501-0

⚠ DANGER
<p>Be Careful with Fire</p> <ul style="list-style-type: none"> When refueling, stop the engine and do not smoke. The filter cap of the fuel tank must be kept tight.
<small>3998-16501-0</small>

⑥ 3998-16535-0

⚠ DANGER
<ul style="list-style-type: none"> Do not open the radiator cap when fluid is hot. Radiator fluid is flammable. Avoid exposure to flame when radiator cap has been removed.
<small>3998-16535-0</small>

⑪ 3998-16507-1

⚠ CAUTION
<p>Lubricate all grease fittings daily prior to commencing work.</p>
<small>3998-16507-1</small>

② 3998-16497-1

⚠ WARNING
<ul style="list-style-type: none"> Thoroughly read the operator's manual before using the machine. Incorrect operation can cause severe injury or death. It is your responsibility to operate the machine safely.
<small>3998-16497-1</small>

⑦ 3998-16536-0

⚠ DANGER
<ul style="list-style-type: none"> Avoid contact with the machine parts in the vicinity of the engine while engine is running and after it has been stopped. Contact with hot parts will cause burns.
<small>3998-16536-0</small>

⑫ 3998-16510-0

⚠ CAUTION
<p>Refill the specified quantity of oil in the vibrator case when changing oil.</p>
<small>3998-16510-0</small>

③ 3998-16500-0

⚠ WARNING
<ul style="list-style-type: none"> Avoid inhalation of exhaust gas. Avoid contact with exhaust pipe while engine is running and after it has been stopped. Contact with hot exhaust pipe will cause burns.
<small>3998-16500-0</small>

⑧ 3998-16505-0

⚠ DANGER
<p>Roll Over Prevention</p> <ul style="list-style-type: none"> Do not work in the vicinity of overhanging banks, or on grades steep enough to cause the machine to slide or roll over. Reduce speed prior to making turns. Pay particular attention when operating on uneven surfaces, as the machine may become unstable.
<small>3998-16505-0</small>

⑬ 3998-16468-1

⚠ CAUTION
<p>When storing this machine, release the parking brake once a month to prevent it from jamming.</p>
<small>3998-16468-1</small>

④ 3998-16489-0

<p>CALIFORNIA Proposition 65 Warning</p> <p>Diesel engine and some of its constituents are known to the State of California to cause cancer, birth defects, and other reproductive harm.</p>
<small>3998-16489-0</small>

⑨ 3998-36002-0 (2 locations)



⑭ 3998-16559-0

<p>DANGER EXPLOSIVE GASES Cigarettes, flames or sparks could cause battery to explode. Always avoid eyes and face from battery. Do not charge or use booster cables or adjust post connections without proper instruction and training.</p> <p>KEEP VENT CAPS TIGHT AND LEVEL</p> <p>POISON CAUSES SEVERE BURNS Contains sulfuric acid. Avoid contact with skin, eyes or clothing. In event of accident flush with water and call a physician immediately.</p> <p>KEEP OUT OF REACH OF CHILDREN</p>
<small>3998-16559-0</small>



⚠ WARNING: Negligence of these instructions can lead to accidents.

1. BASIC SAFETY PRECAUTIONS

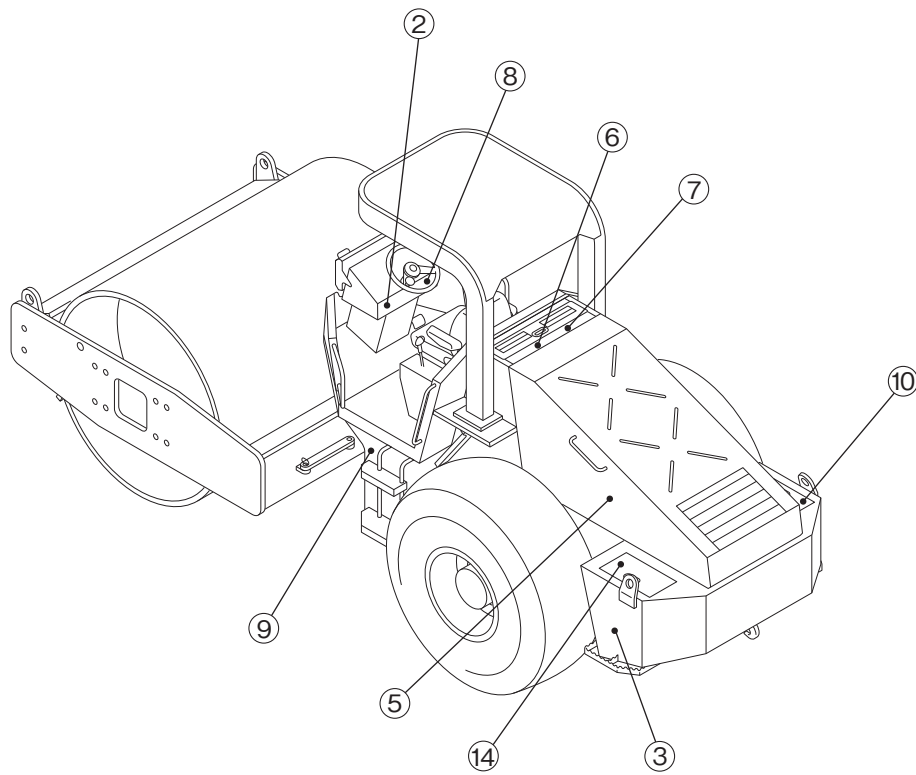
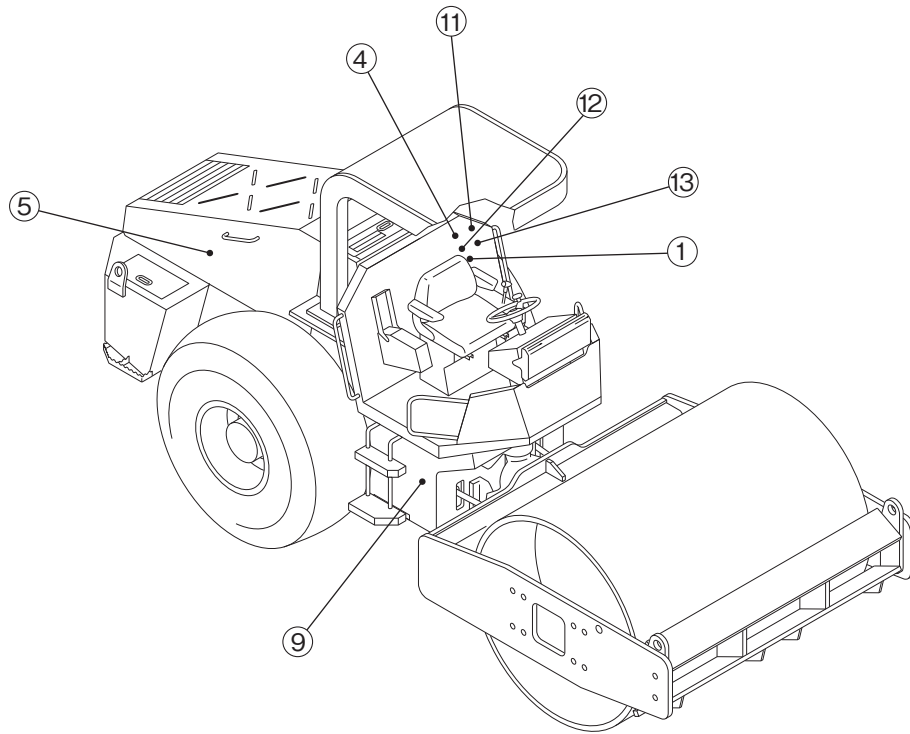

2. OPERATION

2 OPERATION

2.1 Instruments and Controls

2.1.1 Operator's station

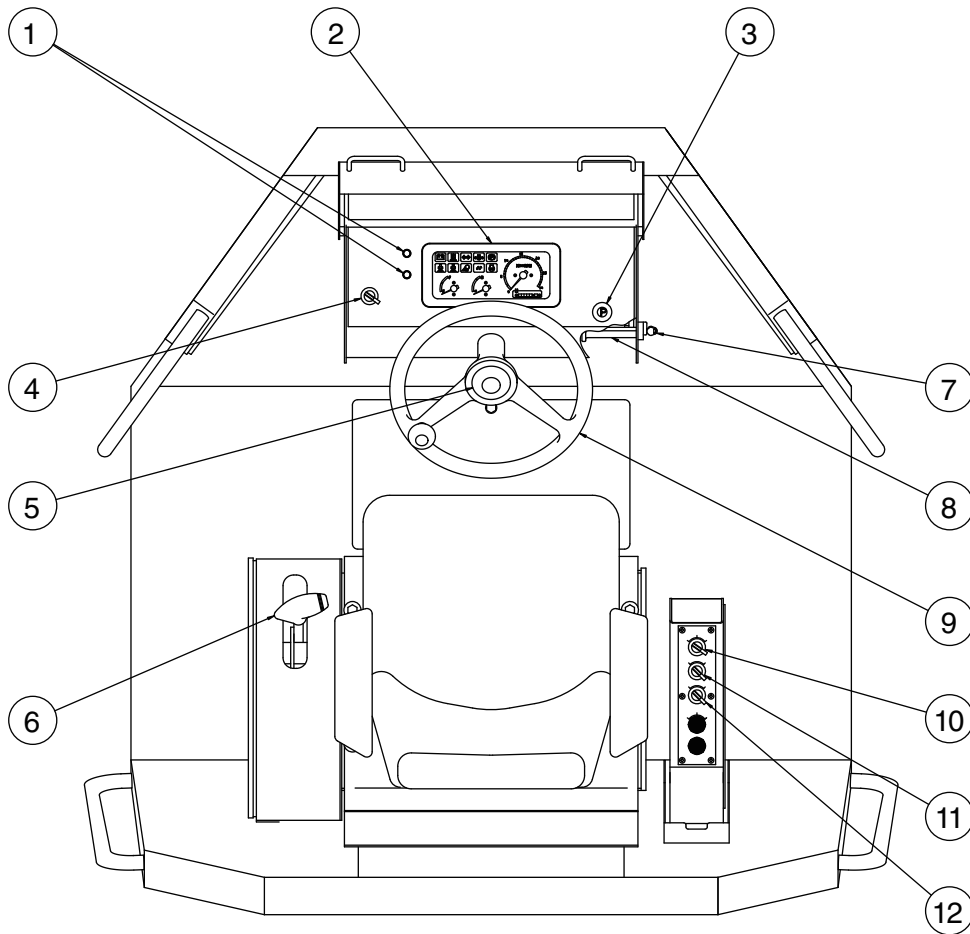

- ① Engine check lamp
- ② Combination meter
- ③ Parking brake switch
- ④ Engine speed change switch
- ⑤ Horn switch button
- ⑥ Forward-reverse (F-R) lever
(For vibrator switch)

- ⑦ Starter switch
- ⑧ Brake pedal
- ⑨ Steering wheel
- ⑩ Vibrator switch
- ⑪ Vibration selector switch
- ⑫ Speed change switch

2.1.2 Gauges, indicator lamps and warning lamps

For safe execution of your job, fully understand the role and function of the systems involved.

Combination meter

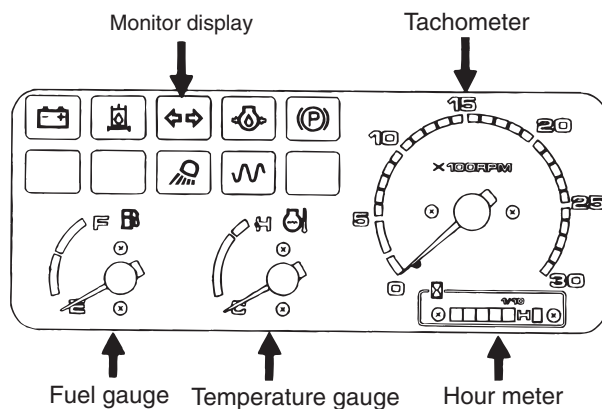

Tachometer

Indicates the engine RPM. The hour meter shows total operating hours. The service interval recommendation in this manual should be based upon the hour meter readings.

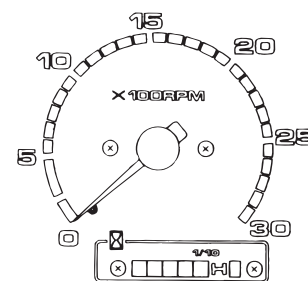

Tachometer/Hour meter

Temperature gauge

Indicates the coolant temperature. Zone close to symbol H indicates overheating. In case of overheating, run the engine at idling for about ten minutes before shutting it down. Then determine the cause.

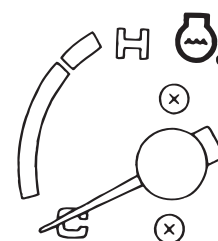

Temperature gauge

Fuel gauge

Indicates the fuel level in the tank.

- E: The tank is empty.
- F: The tank is full.

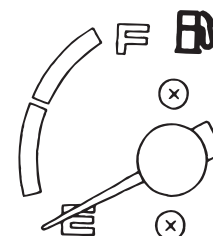

Fuel gauge

Replenish fuel appropriately before the fuel runs down.

⚠ CAUTION



Be sure to use fuel recommended by SAKAI (refer to page 63).

2. OPERATION

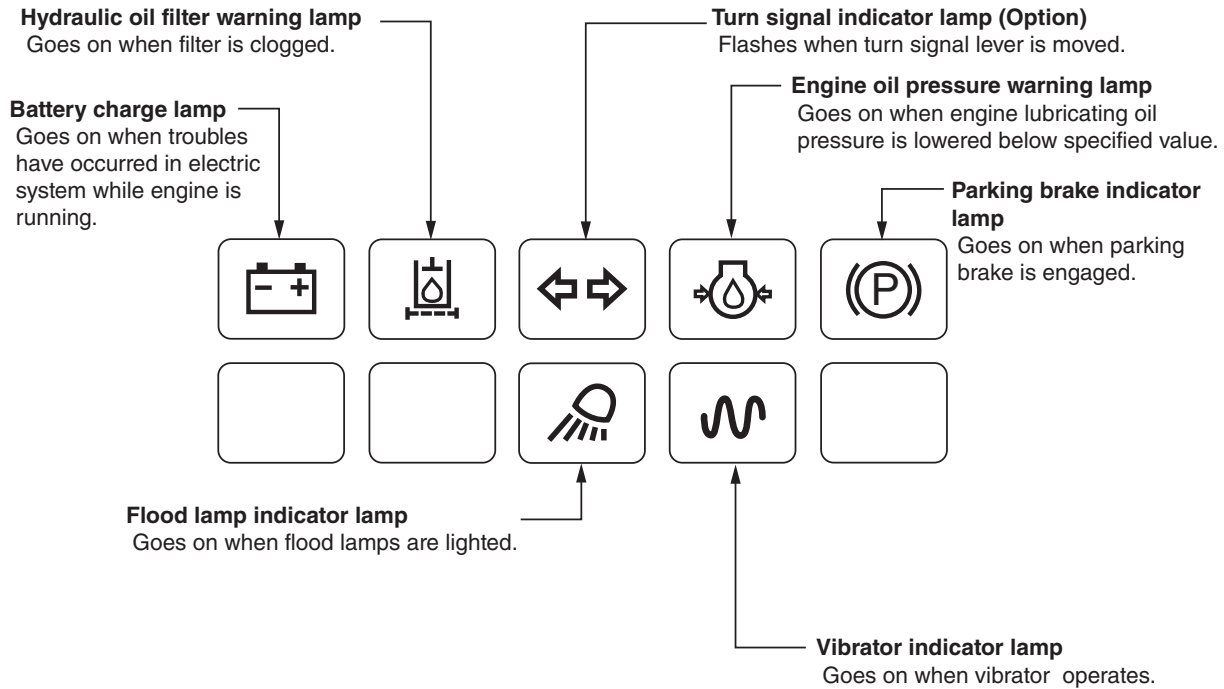
Monitor display



★ Indicator lamps [   ]
Light up when corresponding systems have been operated.

★ Warning lamps [  ]
Go on when the starter switch is turned to the ON position and go off when the engine has started. If any of them lights up while the engine is running, this indicates a faulty condition. Stop the engine and trace the source of trouble.

★ Bulb failure check
= Warning lamps and parking brake indicator lamp =
They should go on when the starter switch is turned to the ON position.
If not, corresponding bulb has burnt out.

⚠ CAUTION

Hydraulic oil filter warning lamp may go on when the engine rpm is increased before the engine has been warmed up enough. Keep the engine idling until the lamp goes off, before starting your work.

Engine check lamp

When the start switch is set to ON position, self-diagnosis of the engine will start.

When the result is normal. Two lamps will go out. If the lamp remains lit or it lights during operation, it means there is any trouble with the engine. Stop the vehicle to check the engine.



ENGINE STOP



WARNING

ENGINE CHECK

★ **ENGINE STOP**

When the Engine Stop lamp lights, it means a serious abnormality occurs with the engine. Stop the vehicle and the engine, and receive proper checking/maintenance or repairing.

★ **WARNING**

When the Warning lamp lights, water may be accumulated in the fuel sump. Drain the sump. (See P54)

If the lamp lights just because the water is accumulated in the fuel sump, it will go out after draining.

If the lamp does not go out, the engine may be abnormal. Receive proper checking/maintenance or repairing before a serious failure occurs.

IMPORTANT

For the details of the Engine Check lamp, see the Instruction Manual of the engine.

2. OPERATION

2.1.3 Switches

Starter switch

Starts and stops the engine.



OFF : The key can be removed in this position. All the electric systems are switched off. To shut down the engine, move the key to this position.

ON : The charging circuit and lamp circuit are charged with electricity. Let the key stay in this position after the engine has started.

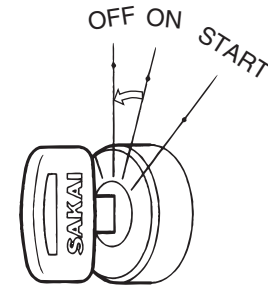
START : The engine is cranked and gets started. The moment the engine has started, release the key. It will automatically return to the ON position.



Parking brake switch

If switch  is pressed down, the parking brake applies with the indicator lamp  on the monitor display lighted up.

When pressed again, the brake is released and the indicator lamp goes off.

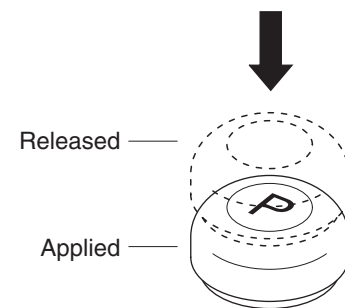

WARNING

- To disengage the brake, be sure to press the button again instead of pulling it.
- When dismantling from the machine, press the button to apply the brake without fail.

CAUTION

Never pull the switch up.

IMPORTANT

In an emergency, apply brake by pressing the parking brake switch button.

Horn switch button

Pressing the button at the center of the steering wheel makes the horn sound.

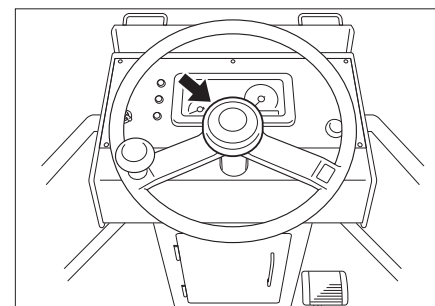

Vibrator switch

By means of vibrator switch located on the panel to the right of operator seat, selection of vibration amplitude and On-Off is mode.

 position: Turning the vibration switch clockwis causes the vibration to start with high amplitude.

OFF position: Vibration is shut down.

 position: Turning the vibrator switch counter clockwise causes vibration to start with low amplitude.

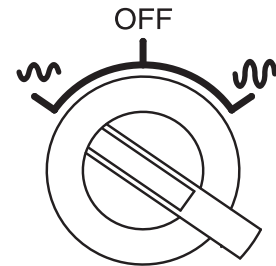

Vibration switch



NOTE: For vibratory rolling, run the engine at 1,800 rpm or higher.

IMPORTANT

Vibrating compaction can be made only when the engine rpm is FULL.

Vibration selector switch

Selection can be mode between the vibrator switch installed to the forward-reverse lever and the other one located on the panel to the right of operator seat.

 position: Vibration can be turned ON or OFF with the switch located on the forward-reverse lever. Pressing this switch causes the vibration to start and pressing it again to stop. This vibrator switch on the lever should be used with the vibrator switch on the panel placed at  or  position.

CONT position: Have this switch placed at this position when vibration is not to be actuated.

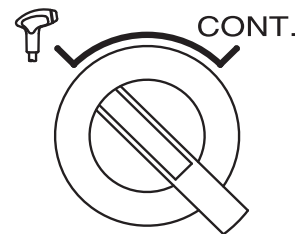

Vibration selector switch

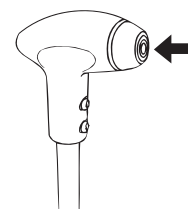

Vibration switch

NOTE: For vibratory rolling, run the engine at 1,800 rpm or higher.



IMPORTANT

- Do not operate the vibrator on a hard area such as cement concrete pavement surface or the ground covered by thick steel sheets.
- Keep the vibrator stopped when the machine is at rest.
- Shut off the vibrator immediately when the machine has been caught in the mud during vibratory operation.

2. OPERATION

Speed change switch

Selects two vehicle speed ranges.

	 (Low)	 (High)
Speed	0 ~ 6 (0 ~ 3.7)	0 ~ 10 (0 ~ 6.2)

km / h (mile / h)

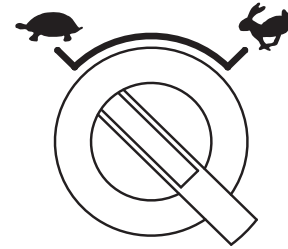

Engine speed change switch

Shifts the engine RPM.

	(±50 min ⁻¹)		
Engine speed	IDOLE	MID	FULL
	900 min ⁻¹	1800 min ⁻¹	2300 min ⁻¹

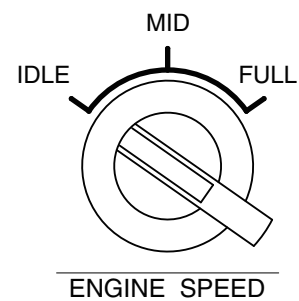

2.1.4 Operating levers / pedals

Forward reverse lever (F-R lever) with vibration switch

Moving the F-R lever forward or backward makes the machine travel forward or backward respectively. The neutral position brings the machine to a stop. The vehicle speed increases or decreases in proportion to the lever displacement.

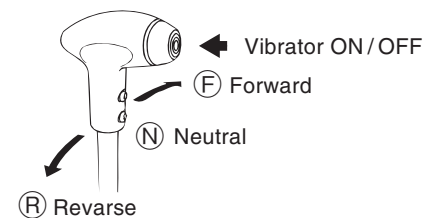

Provided at the knob of the lever is the vibration switch for turning on or off the vibration.

IMPORTANT

- For normal braking, return the F-R lever back to neutral.
- In an emergency, depress the brake pedal or press the parking brake button.

Brake pedal

In an emergency, push down on the pedal to the full extent, and the machine will come to a sudden stop.

NOTE: Depressing the brake pedal all the way causes reversible travel lever to return to neutral position **(N)** as well.

IMPORTANT

Do not use the pedal wherever practicable except for an emergency.

2.1.5 Unloader valve

The unloader valve disengages the drive, playing a role like a clutch. Use this valve for towing the machine when the engine is disabled or when troubles have developed in the hydraulic drive.

For towing:

Turn the knob counter-clockwise (Unload).

For normal traveling:

Turn the knob clockwise (Onload).

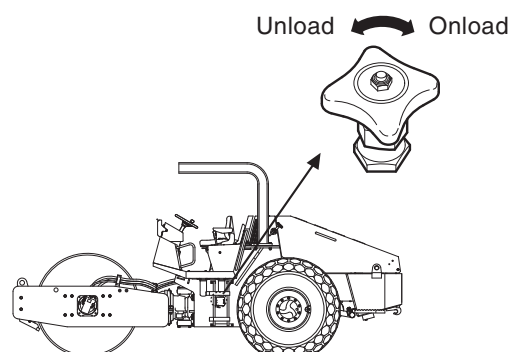
**⚠ WARNING**

- **On a slope, chock the wheels and use extreme care when handling the unloader lever and towing the machine.**
- **Be sure to apply the parking brake when operating the unloader lever.**

NOTE: For normal travel, be sure to hold the unloader in the ONLOAD position.

2. OPERATION

2.1.6 Fuse box

⚠ WARNING

When changing a fuse, cut the power supply by turning the starter switch to the OFF position.

Fuses protect electrical components and wiring from burning. Change any fuse which has become powder-coated due to deterioration or which has a play between it and fuse holder. To replace fuses, take off the cover. Be sure to use fuses of correct capacity.

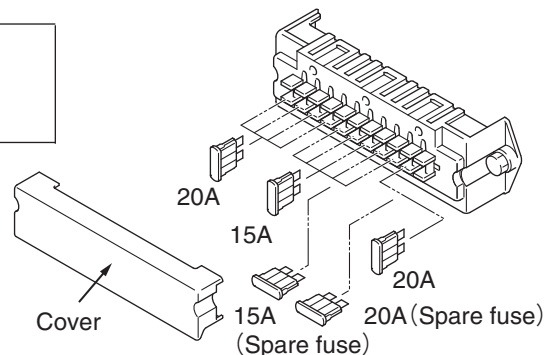

2.2 Handling and Adjustments

2.2.1 Seat adjustment

Adjust the seat for your best operating position. Move the lever as shown by arrow. With the lever held in that position, slide the seat forward or backward as desired. When properly adjusted, release the lever.

Adjust your seat position to suit you as follows:

- 1) Pull the lever ① and adjust seat position longitudinally.
- 2) Turn the backrest adjust dial ② for optimum angle.
- 3) Move the suspension lever ③ to select suitable suspension for your body weight.

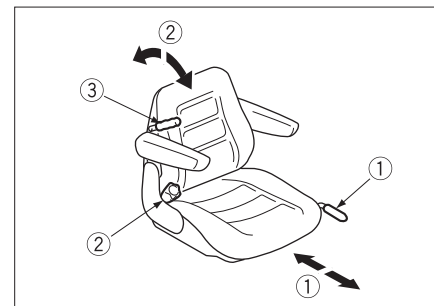

⚠ WARNING

The adjustment will be necessary when operating the machine first or when operators are alternated.

2.2.2 Scraper adjustment and replacement

SV510D-III

1) Clearance adjustment of scraper ①

- ① Loosen bolts and nuts ② at 8 locations.
- ② Provide a clearance of 20 mm between scraper and the drum.
- ③ Retighten bolts and nuts ② at 8 locations.

2) Clearance adjustment of scraper ④

- ① Loosen bolts and nuts ④ at 8 locations.
- ② Provide a clearance of 20mm between scraper and the drum.
- ③ Retighten bolts and nuts ④ at 8 locations.

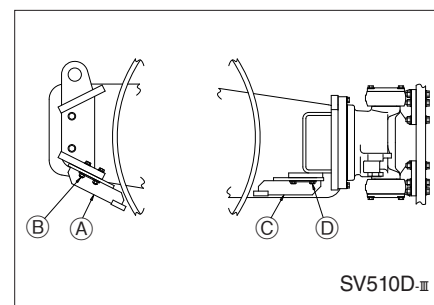

2. OPERATION

SV510T-III

1) Clearance adjustment of scrapers (A)

- ① Loosen bolts and nuts (B) (4 locations) and (D) (16 locations) at bottom.
- ② Provide a clearance of 20mm between scrapers (A) and the drum.
- ③ Retighten bolts and nuts (B) (4 locations) and (D) (16 locations) .

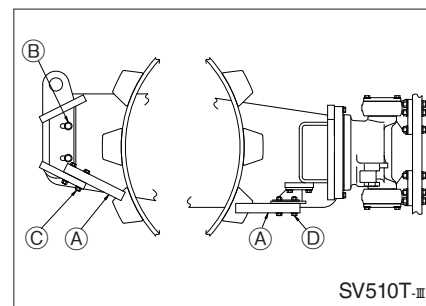

2) Replacement of scrapers (A) (9 pieces on top and 8 pieces at rear.)

- ① Remove bolts and nuts (C) and (D) .
- ② Replace scrapers (A) with new ones.
- ③ Refit and retighten bolts and nuts (C) and (D) .

SV510TF-III

1) Clearance adjustment of scraper blades (A) .(One at the right and one at the left)

- ① Loosen bolts and nuts (B) (8 locations respectively at front and rear)
- ② Provide a clearance of 20mm between scrapers (A) and the drum.
- ③ Retighten bolts and nuts (B) (8 locations respectively at front and rear)

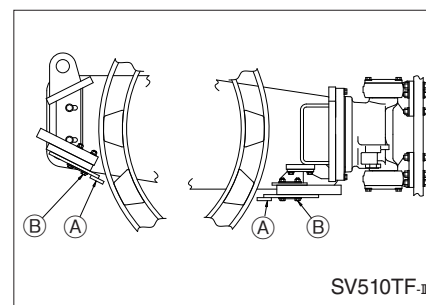

2) Replacement of scraper blades (A)

- ① Remove bolts and nuts (B) (8 locations respectively at front and rear)
- ② Replace scraper blades (A) with new ones.
- ③ Refit and retighten bolts and nuts (B) (8 locations respectively at front and rear)

2.2.3 Disengaging the brake when towing

⚠ WARNING

- **On a slope, chock the drums and prepare for towing before disengaging the brake.**
- **Avoid a long-distance towing.**

For towing the machine when the engine is disabled or when troubles have developed in the hydraulic system for propulsion, disengage the brake as instructed below:

2. OPERATION

1) Rear brake

- ① Loosen the lock nuts (B) .Tighten bolts (A) so as to fasten them onto the pressure plate (D) .
- ② Using a wrench,tighten the bolts (A) in an alternate sequence by 1/4 turn at a time so as to compress the Belleville washers and disengage the braking disks.

IMPORTANT
Tighten max. by one turn.

- ③ After towing is completed, remove bolts (A) completely with nuts (B) and seals (C) . Then,replace seals (C) , apply silicone-based Tecno Lupu/101 grease to the bolts (A) and install all parts again.
- ④ Adjust bolts (A) to obtain a jut of $34^{+0.5}_0$ mm. then, lock into position with nuts (B) .

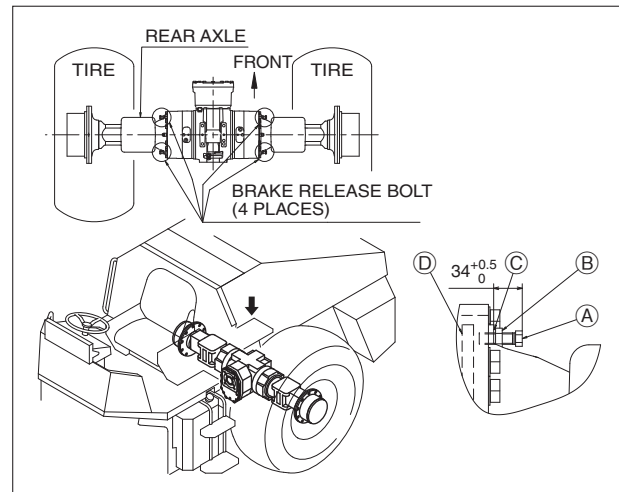

⚠ WARNING

- Do not try to release the brake immediately after a hot engine has been stopped. Let the oil cool down.
- For the brake disengagement, wear hard hat, safety goggles and safety gloves.



2.2.4 Handling of Diagnostics On / Off switch and Increment / Set-Decrement / Resume switch

This is used for failure diagnosis of the engine. Normally, the switch should not be operated. The position of the switch lever is as shown in the figure during normal operation.

IMPORTANT

For operating the Diagnostics On / Off switch and Increment / Set-Decrement / Resume switch, see the Instruction Manual of the engine.

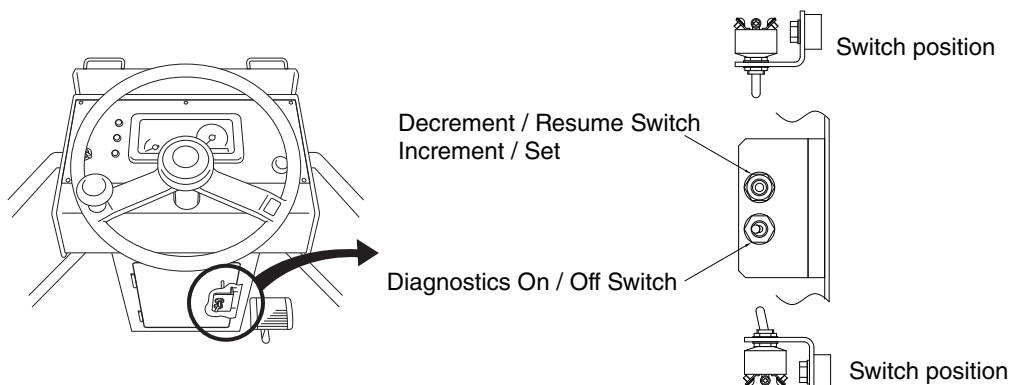

2.3 Operation

⚠ WARNING

- This machine is a one-man roller.
- Operate the machine from the operator's seat.

2.3.1 Before-starting inspection

1) Check that the steering lock bar is in the carrying position.

⚠ WARNING

Make sure that the steering lock bar is connected in the carrying position before putting the machine in motion. Steering is impossible if the bar is in the steering lock position.

The bar is located at the left of the center of the machine.

To unlock the bar:

- ① Remove the spring pin.
- ② Pull out the lock pin.
- ③ Set the bar in the carrying position.

NOTE: Retain the lock bar in the locked position by inserting the lock pin into the lock holes. Fix the lock pin with the spring pin.

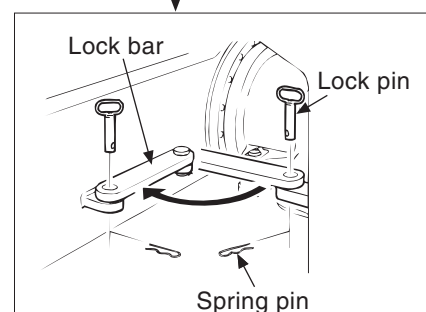
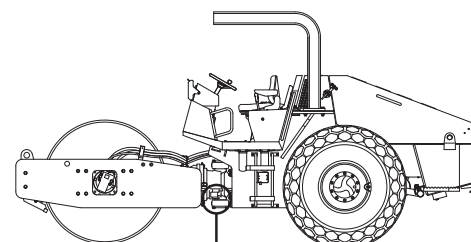

2) Check that the F-R lever and is in the neutral position (N).

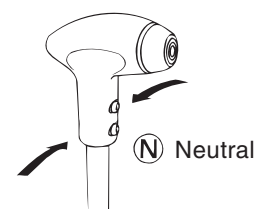

NOTE: The engine does not start if the F-R lever is not in the neutral position.

2. OPERATION

2.3.2 Starting the engine

⚠ WARNING

Check that the F-R lever is in the neutral position, and sound the horn when starting the engine after making certain that there are no one and no objects close to the machine.

- 1) Set the engine speed change switch in IDLE position.

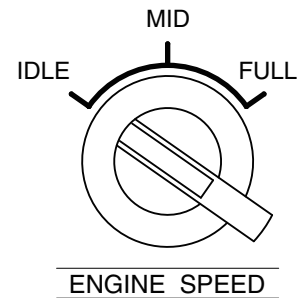

- 2) Turn the starter switch to the ON position and check that the warning lamps and parking brake indicator lamp on the monitor display are on.

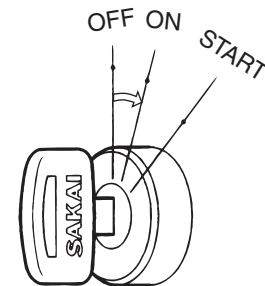

- 3) Check that the engine check lamp goes out, and then start the engine.

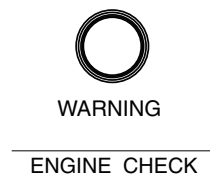

- 4) Turning the key to the START position makes the engine start. Release the key the moment the engine has started. The key will automatically return to the ON position.

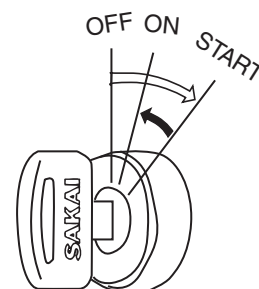

⚠ CAUTION

- Do not allow the starter key to stay in the START position for more than 15 seconds.
- If the engine does not start, allow an interval before trying again.
- Check that the warning lamps on the monitor display go off immediately after the engine is started. If any of these warning lamps becomes bright while the engine is running, shut down the machine, determine the cause and rectify the fault.

2.3.3 After starting the engine

Try not to move to operation immediately after starting but observe the following:

IMPORTANT

Avoid increasing the engine speed abruptly before warming-up run is completed.

- 1) Run the engine at idling for about 5 minutes to warm it up. Warming-up run allows the lubricating oil to reach the vital parts of the engine and hydraulic system, while gradually bringing up the engine oil and hydraulic oil to the working temperature.
- 2) After the warm-up operation, check that:
 - Temperature gaugePointer falls near the center zone.
 - Fuel gaugePointer falls between the E and F marks
 - Charge lamp.....Has gone off.
 - Engine oil pressure warning lampHas gone off.
 - Engine check lamp.....Has gone off.
- 3) Check for the color of exhaust gas, listen for unusual sounds and vibration. If abnormal, determine the cause and correct the problem.

2. OPERATION

2.3.4 Traveling



⚠ CAUTION

While travelling, do not turn the starter switch OFF.

⚠ WARNING

When starting, operate the horn after securing the safety around the machine.

- 1) Select the desired speed by the speed change switch.

	 (Low)	 (High)
Speed	0 ~ 6 (0 ~ 3.7)	0 ~ 10 (0 ~ 6.2)

km / h (mile / h)

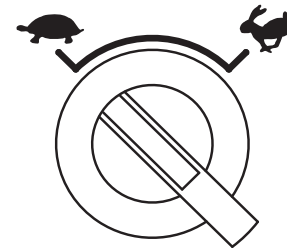

⚠ WARNING

On a steep slope, run the machine at low speed.

- 2) Increase the engine speed by turning the engine speed change switch.

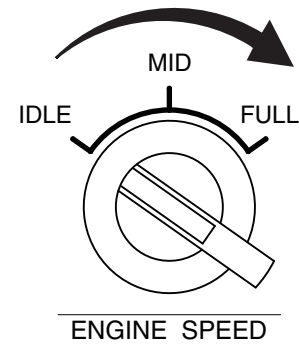

- 3) Press down the parking brake switch button to release the brake. Check that indicator lamp  on the monitor display goes off.

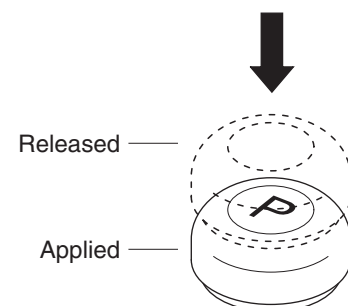

- 4) Move the F-R lever in the direction to travel, and the machine will begin traveling.

⚠ CAUTION
Avoid abrupt operation of the F-R lever.

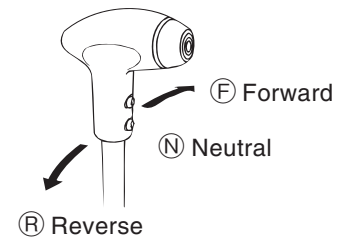

NOTE: The travel speed can be controlled by the throttle lever and F-R lever.

⚠ WARNING
Pay extreme attention to the area behind the machine when backing, since the space just behind it tends to be a blind spot.

- 5) The driving force of this vehicle is controlled automatically. Please contact your distributor when you feel there is something wrong with its driving force.

2.3.5 Stopping / Parking

⚠ WARNING

- **Avoid abrupt braking. Try to leave enough time for braking.**
- **Avoid parking on a grade.**
- **If necessary to park on a grade, block the wheel to prevent unexpected moving down the grade.**

- 1) Bring the F-R lever to the neutral position (N), and the machine will come to a halt.

⚠ CAUTION

- **For normal braking, move the F-R lever back to the neutral position. In an emergency, depress the brake pedal.**

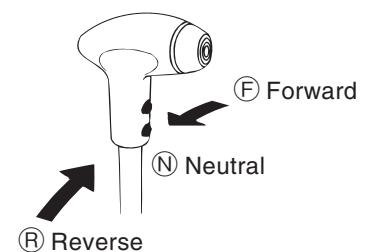

- 2) Press the parking switch button securely, and check that indicator lamp (P) illuminates.

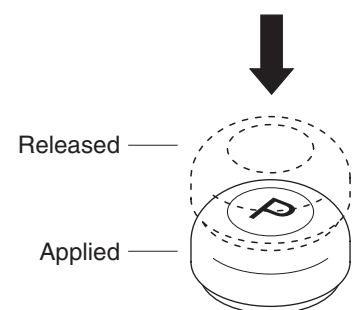

2. OPERATION

2.3.6 Stopping the engine

- 1) Gradually cool down the engine at low idling for about 5 minutes.

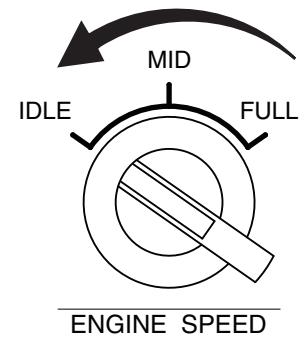

IMPORTANT

- Do not bring a hot engine to a sudden stop except for an emergency. This will shorten the life of its component parts.
- Do not also allow an overheated engine to come to a sudden stop, but run it at middle idling speed for gradual cooling down.

- 2) Turn the starter key to the OFF position to stop the engine.

CAUTION

Do not turn the starter switch OFF while the machine is in motion.

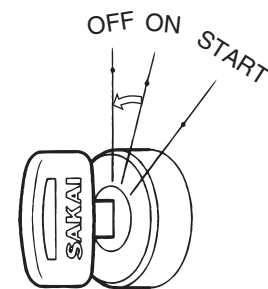

- 3) Remove the starter key.

WARNING

- When dismantling from the machine, apply the brake by pressing the parking switch button. If necessary to park on a grade, block the wheels to prevent unexpected moving down the grade.
- Never fail to remove the starter key

2.3.7 Check after stopping the engine

- 1) Perform the walk-around checks for oil and water leakage, abnormal signs around the drums.
- 2) Fill the fuel tank.
- 3) Remove waste paper if any from the engine compartment, as this will pose a possible fire hazard.
- 4) Scrape mud or other materials from and around the drums.

2.4 Vibratory Operation

1) Set the Engine Speed switch to FULL.

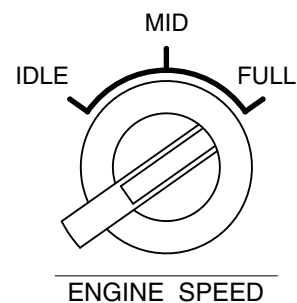

2) Amplitude of vibration is selectable and turned on and off with the vibration switch (A) located on control panel to the right of operator seat.

 position: Turning the vibration switch clockwise causes the vibration to start with high amplitude.

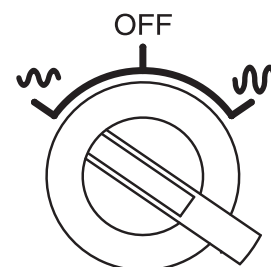

OFF position: Vibration is shut down.

 position: Turning the vibration switch counter clockwise causes vibration to start with low amplitude.



Vibration switch (A)

Also, by means of vibration selector switch (B), the selection can be made between the vibration switch (C) installed to the forward-reverse lever and the other one located on the panel to the right of operator seat.

 position: Vibration can be turned ON or OFF with the switch located on the forward-reverse lever. Pressing this switch causes the vibration to start and pressing it again to stop. This vibration switch on the lever should be used with the vibration switch on the panel placed at  or  position.

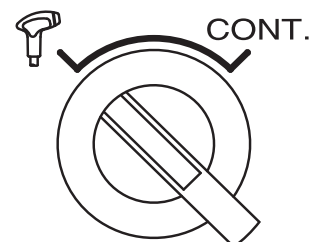

Vibration selector switch (B)

CONT position: Have this switch placed at this position when vibration is not to be actuated.

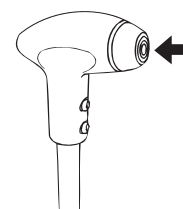

Vibration switch (C)

3) Proper travel speed for vibratory compaction is 2 ~ 5 km/h, however, select speeds depending upon job requirements.

4) The driving force of this vehicle is controlled automatically. Please contact your distributor when you feel there is something wrong with its driving force.

IMPORTANT

- Keep the vibrator shut off when the machine is not rolling.
- Stop vibration if the machine has encountered a running difficulty, for example, when it gets stuck in the mud.

2. OPERATION

2.5 Precautions for Work

2.5.1 Compaction operation

■ Do not operate the vibrator on hard location

- Do not work the vibrator on a hard surface such as concrete pavement, as this can cause the machine to jump and give abnormal shock load. Damage to shock isolators will result.

■ Change the direction of travel gently.

- When changing the direction of travel during asphalt mix compaction, slowly shift the F-R lever.

2.5.2 When going downhill

■ Use the F-R lever.

- Run slowly by the operation of the F-R lever even if the travel distance is short.

■ Use the engine brake

- Go downhill by applying the engine brake along with the F-R lever operation.

⚠ WARNING

- When going uphill, run at low speed. Do not attempt to shift speeds during travelling. The machine can slip down the slope.
- When going downhill, adjust the travel speed not to allow the engine speed to exceed 2,500 rpm.

2.5.3 On a slope

■ Working on a sidehill

- Work in an uphill/downhill direction, and avoid working on sidehill with the machine inclining sideways.

2.6 Applicable Jobs

1) This machine is mainly used for:

- Static compacting work
- Vibratory compacting work

2) Road rollers do a variety of jobs as listed below.

This machine most effectively handles works or materials marked ☆ .

Work

- Asphalt road paving
- Dust removal treatment for road
- ☆ Road improvement
- ☆ Embankment construction
- ☆ Dam construction
- Construction of forestry and farm roads
- Foundation building
- Construction of sidewalk, shoulder and gutter foundation

Material to be compacted

- Asphalt pavement
- ☆ Crusher run
- ☆ Cement concrete
- ☆ Sands
- ☆ Soils
- ☆ Slag
- ☆ Soft rock

Layers to be compacted

- Surface course, Binder course
- ☆ Base course
- ☆ Subgrade
- ☆ Embankment
- Shoulder
- Sidewalk

2.7 After Operation

Check for the coolant temperature, engine oil pressure and fuel level.

Follow the procedures below to prevent the machine from falling into an unworkable condition the following morning caused by muds and other extraneous matter on the drum, or frozen drums:

- 1) Remove muds and water from the machine. Muds can get into the seals together with water drops on the hydraulic cylinder piston rod. Damaged seals will result.
- 2) Park the machine on a hard and dry surface. If such a place is not available, cover the ground with hard plates.
- 3) Low temperature will cause a significant reduction of battery efficiency. Cover batteries or take them off from the machine and store in a warm place for the following day's operation.

2. OPERATION

2.8 Loading and Unloading

⚠ WARNING

- Use sturdy ramps with proper width, length and thickness which allow safe loading and unloading.
- If the ramps deflect considerably under load, apply wooden blocks to reinforce them.
- Loading should be conducted on a level and hard ground. Leave a sufficient distance between the machine and the shoulder.
- To prevent slippage on the ramps, keep the drums free from mud, oils, etc. The ramps must also be free of grease, oil and ice.
- Do not steer the machine on the ramps. If the machine is facing in the wrong direction, allow it to dismount from the ramps and correct the direction.

For loading and unloading, use ramps or a proper loading stand.

2.8.1 Use of a trailer equipped with a winch

⚠ WARNING

Placing the unloader valve in UNLOAD position disrupts the power for traction. Do not enter the areas ahead of and behind the machine. It is very dangerous.

- 1) Engage the trailer brake and chock its wheels. Fix the ramps so that the machine and trailer are completely aligned.
 - ☆ The angle between the ramps and ground must be less than 15 degrees.
 - ☆ Leave a proper space between the ramps according to the width of the roller drum.
- 2) Decide the correct direction of run and make the machine run forward to the ramps.

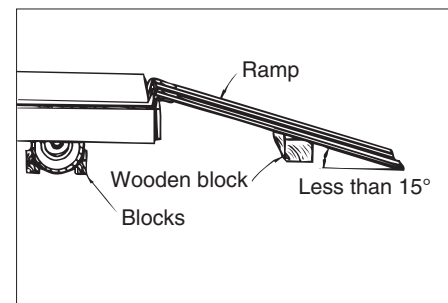

- 3) Draw the wire rope from the trailer winch and put its hook on the hooking point ① or ② (One each on right and left) of the roller.
- 4) Place the unloader valve located at the operator's station to the UNLOAD position (See "Unloader valve" on page 25).
- 5) With the engine running at idle, perform loading by means of the trailer winch.
- 6) When the loading is completed, set the unloader lever back in the ONLOAD position.
- 7) Locate the machine correctly on the trailer.

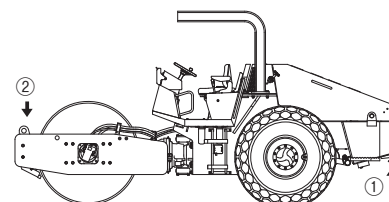

2.8.2 Self-propelling

- 1) Engage the trailer brake and chock its wheels. Fix the ramps so that the machine and trailer are completely aligned.
 - ☆ The angle between the ramps and ground must be less than 15 degrees.
 - ☆ Leave a proper space between the ramps according to the width of the roller drum.

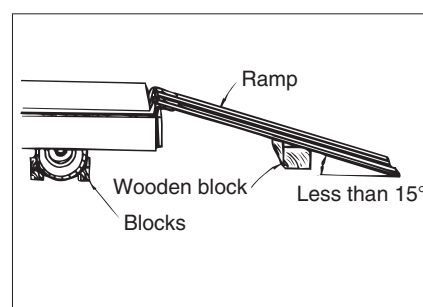

- 2) Decide the correct direction of run and conduct loading or unloading at low speed.

For loading, run forward at low speed.
 For unloading, run backward at low speed.

- 3) Locate the machine correctly on the trailer.

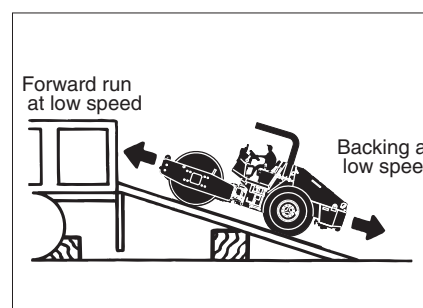

2. OPERATION

2.9 After Loading the Machine

When the machine has been located properly on the trailer, tie it down as follows:

- 1) Press the parking switch button to apply the parking brake. Place wooden blocks under the drums to prevent movement.
- 2) Fix the machine with ropes tied at the front and rear towing hook holes. Particularly, pay attention to sidewise skidding.

2.10 Transportation

⚠ WARNING

To decide the transporting route, check the width of the road, height and weight (including the roller) of the trailer.

For transportation, obey traffic regulations.

2.11 Operation in Cold Weather

In cold weather, take the following measures to prevent troubles such as starting difficulty and coolant freeze-up.

2.11.1 Fuel oil and grease

Use fuel and oil with low viscosity. See "Rating" on page 63.

2.11.2 Coolant

⚠ WARNING

Do not bring an open flame to the antifreeze or do not smoke when handling it. It is inflammable.

⚠ CAUTION

Never use methanol-, ethanol- and propanol-base antifreeze.

Use soft water for coolant.

Ambient temperature	Always
Amount of anti-freeze	8.8 ℓ (2.3 gal)
Amount of coolant	8.8 ℓ (2.3 gal)
Ratio	50%

Our vehicles are filled with a long-life coolant (non-amine type).
The validity of the antifreeze is for two years.
Use non-amine type long-life coolant when changing coolant.

IMPORTANT

Charge the cooling water at the rate of 3 gal / min or less.

2. OPERATION

2.11.3 Battery

⚠ WARNING

- **Batteries generate explosive gases. Do not use an open flame close to batteries.**
- **The battery electrolyte is corrosive. Keep the electrolyte away from your eyes and skin. If you are affected by the electrolyte, flush with large quantities of water and get medical help.**

At low temperature, batteries are less efficient. The level of charge is lowered and batteries will tend to freeze. Maintain batteries full charged wherever practicable, and give attention to heat insulation at night for the next day's operation.

For the level of charge, check the specific gravity of electrolyte and use the following table of conversion.

Temperature Level of charge (%)	20°C (68°F)	0°C (32°F)	-10°C (14°F)	-20°C (-4°F)
100	1.28	1.29	1.30	1.31
90	1.26	1.27	1.28	1.29
80	1.24	1.25	1.26	1.27
75	1.23	1.24	1.25	1.26

2.12 When the Cold Season is Over

When winter is over and the warm season has come, proceed as follows:

- 1) Change oil and fuel with those for use in warm season referring to "Rating" on page 63.
- 2) If AF-PT antifreeze is in use, drain the coolant completely, wash clean inside the cooling system, and then fill with clean water (city water).

2.13 For a Long Storage Period

For leaving the machine unused for longer than one month, proceed as follows:

- 1) Store the machine in a closed area after cleaning.
- 2) Conduct oiling, greasing and changing of oil.
- 3) Grease lubricate the exposed portion of hydraulic cylinder piston rods.
- 4) Cover the battery after disconnecting the negative cable or take off the battery from the machine and store in a safe place.
- 5) If the temperature is expected to go down below 0°C, add antifreeze to the coolant.
- 6) With F-R lever placed at neutral position (N) and vibrator switch at OFF position, have the parking brake engaged.
- 7) Chock the machine.
- 8) Remove the starter switch key.

2.14 During the Storage Period

⚠ WARNING

If necessary to operate the machine for anti-corrosive purpose in closed area, ensure good ventilation keeping windows and doors open to prevent gas poisoning.

- During storage, operate the machine at least once a month to prevent the oil films on the lubricated parts from deteriorating and to charge the batteries.
- To prevent the brake linings from sticking to the brake drum, disengage the brake once a month. Exercise care not to allow the machine to move unexpectedly.

2. OPERATION

2.15 When the Battery Has Discharged

⚠ WARNING

- To check and handle the batteries, keep the engine stopped with the starter switch in the OFF position.
- The batteries give off explosive gases. Do not smoke close to the batteries. Keep flames and sparks away from the batteries.
- The electrolyte is very corrosive and will harm your clothing or skin. If the electrolyte has come into contact with your clothing or skin, flush with sufficient amount of water. In case the electrolyte has gotten into your eyes, flush with water and get medical help.
- To disconnect the battery cables, start with the negative terminal (earth). When connecting, start with the positive terminal. Do not allow a metallic item to bridge between the positive terminal and machine body. This can generate sparks, causing an explosion.
- Loose battery terminals can cause sparks. An explosion will result. When connecting the terminals, make certain that they are tight.

Disconnect with negative cable first

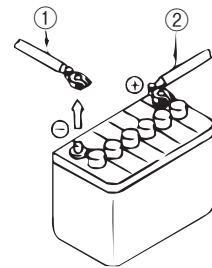

Connect with positive cable first

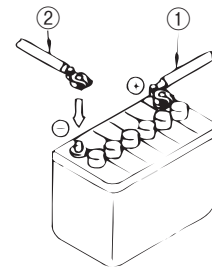

2.15.1 Connection and disconnection of booster cables

When jump-starting the engine, connect the booster cables as follows:

■ Connection of booster cables

- 1) Connect one end of the positive booster cable (A) to the positive (+) terminal of the battery on the machine.
- 2) Connect the other end of the positive booster cable to the positive (+) terminal of the booster supply.
- 3) Connect the negative booster cable (B) to the negative (-) terminal of the booster supply.
- 4) Connect the other end of the negative booster cable to a good earth of the engine block of the machine.

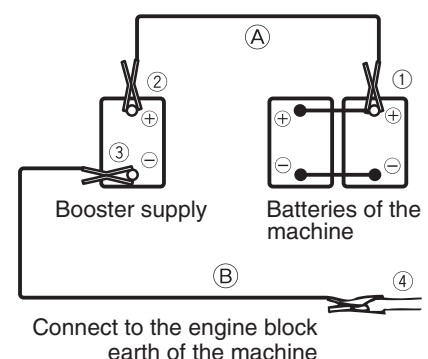

■ Disconnection of booster cables

- 1) Disconnect the negative booster cable (B) from the engine block earth.
- 2) Disconnect the negative booster cable (B) from the booster supply.
- 3) Disconnect the positive booster cable (A) from the booster supply.
- 4) Disconnect the positive booster cable (A) from the machine.

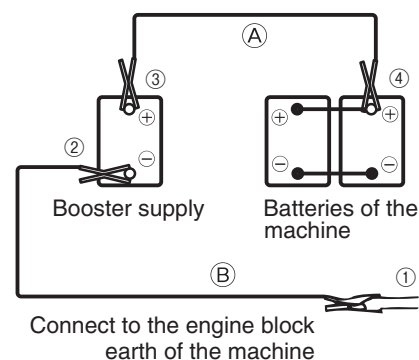

⚠ WARNING

- Do not allow the positive (+) terminal to make contact with the negative (-) terminal when connecting the booster cables.
- Wear safety goggles when jump-starting the engine.
- Do not allow the machine to make careless contact with the booster supply.
- Do not make wrong connections. Connect the negative (-) cable to the engine block earth far away from the battery, as sparks may occur when connecting.

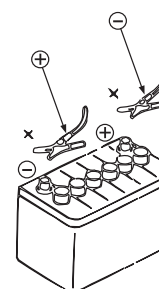

⚠ CAUTION

- Use booster cables and end clips of proper size suited to the battery capacity.
- Use the batteries of the equal capacity for the machine and booster supply.
- Check booster cables and end clips for signs of damage and corrosion.
- Connect the clips positively.

3 PERIODICAL MAINTENANCE

3.1 Precautions

Whether or not the inspection service and lubrication are performed at the correct regular intervals exerts significant influence on the occurrence of trouble and service life of the machine. In this manual, typical intervals for inspection and service are given. However, flexibility should be introduced as to interval or type of services to enable your machine to always operate in the best condition.

General precautions:

- 1) Always use Sakai genuine parts for replacement.
- 2) Use lubricants recommended by Sakai. Avoid mixing different brand lubricants.
- 3) For hydraulic oil replenishment, changing, level checking, filter cleaning or replacement, oiling and greasing, use extreme care to prevent dust from entering.
- 4) For checking oil level or changing oil, park the machine on a level and hard surface.
- 5) Change oil while its temperature remains high after operation.
- 6) For a long-term storage, fill the fuel tank, lubricate necessary points and run the machine for more than 20 minutes once a month.
- 7) In freezing weather, add antifreeze to the coolant according to the ambient temperature.
- 8) For the hydraulic pump and motor, have them serviced at authorized service shops.
- 9) Turn the starter switch OFF when performing services such as repairing broken wires, short circuits and tightening loose terminals.

Periodical replacement of essential maintenance parts

In order secure safety for work and travel, conduct inspection and services.

Further, for enhanced safety, following parts and components should be replaced periodically. These parts are prone to material deterioration due to aging or physical change due to friction, while it is difficult to determine their useful limit by regular inspection, which makes it necessary to replace with new ones after certain period of service to maintain their perfect function.

If any abnormality is detected such as crack, deformation or oil leakage, go ahead and replace them even if it is within scheduled replacement time.

3. PERIODICAL MAINTENANCE

System or Mechanism	Part name	Periodical replacement maintenance part	Replacement period	Remarks
1.Brake system	Master cylinder	Seals (rubber parts)	2 years	Adopted machines only
	Wheel cylinder	Seals (rubber parts)	2 years	∕
	Brake piping parts	Brake hose	2 years	
		Air hose	2 years	Adopted machines only
	Operating parts	Cable	4 years	∕
2. Steering system	Orbitrol	Seals (rubber parts)	2 years	
	Hydraulic piping parts	Hydraulic hose	2 years	
	Steering cylinder	Seals (rubber parts)	2 years	
	Hydraulic pump	Seals (rubber parts)	4 years	
3. Power transmission system (inclusive of axle)	Axle	Seals (rubber parts)	4 years	Adopted machines only
	Travel pump	Seals (rubber parts)	4 years	∕
	Travel motor	Seals (rubber parts)	4 years	∕
	Hydraulic piping parts	Hydraulic hose	4 years	∕
	Isolation rubber	Isolation rubber itself	4 years	∕
4. Fuel system	Piping parts	Fuel hose	4 years	
5. Engine related	Engine mounting parts	Isolation rubber	4 years	
	Seals (rubber parts)	Packing and others	4 years	
	Drive parts	V-belt	2 years	
6. Cooling system	Piping parts	Radiator hose	2 years	
7. Control related parts	Cable	Cable	4 years	Adopted machines only

⚠ CAUTION

- **With a new machine, change the engine oil and change the engine oil filter elements after 50 hours of operation for the first time only. (Refer to page 55)**
- **When trouble occurs in the location indicated by the indicator lamp on the monitor display, sensor will work and corresponding lamp comes on. If this occurs, conduct necessary service regardless of the periodical service interval recommendation.**
 - 1) **The hydraulic filter (line filter) warning lamp ⇨ Replace elements**
- **Check the electric wiring at a regular interval not exceeding one month:**
 - 1) **Damage to the wire harness and loose clamps**
 - 2) **Loose sockets**
 - 3) **Function of electrical systems**

3. PERIODICAL MAINTENANCE

3.1.1 Lifting the machine on a hoist

⚠ WARNING

- Get a qualified personnel to lift and lower the machine on a hoist.
- Use sturdy wire ropes.
- Lock articulation by means of lock bar located at the center of machine.

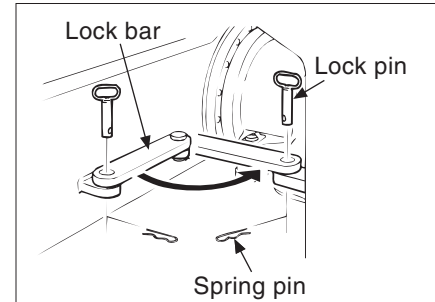

⚠ CAUTION

To do the lifting and lowering work, fold the awning.

- 1) Put wire ropes securely on the hook and lifting points as shown.
- 2) If wire ropes make contact with other parts of the machine, put pieces of cloth or wooden blocks at the contact points. Carefully perform lifting.
- 3) When lifting, keep the machine properly balanced.

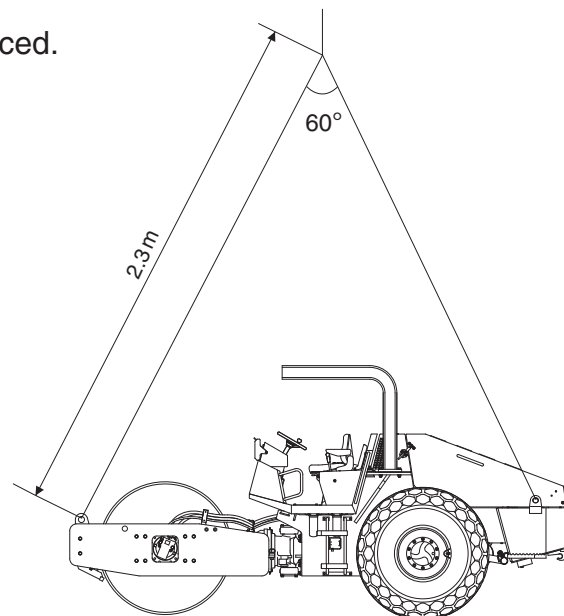

3.2 Walk-around Checking

For efficient operation, daily, before-operation checking is very important. Before starting, perform walk-around checking for loose bolts, nuts and signs of leakage in addition to items as shown below:

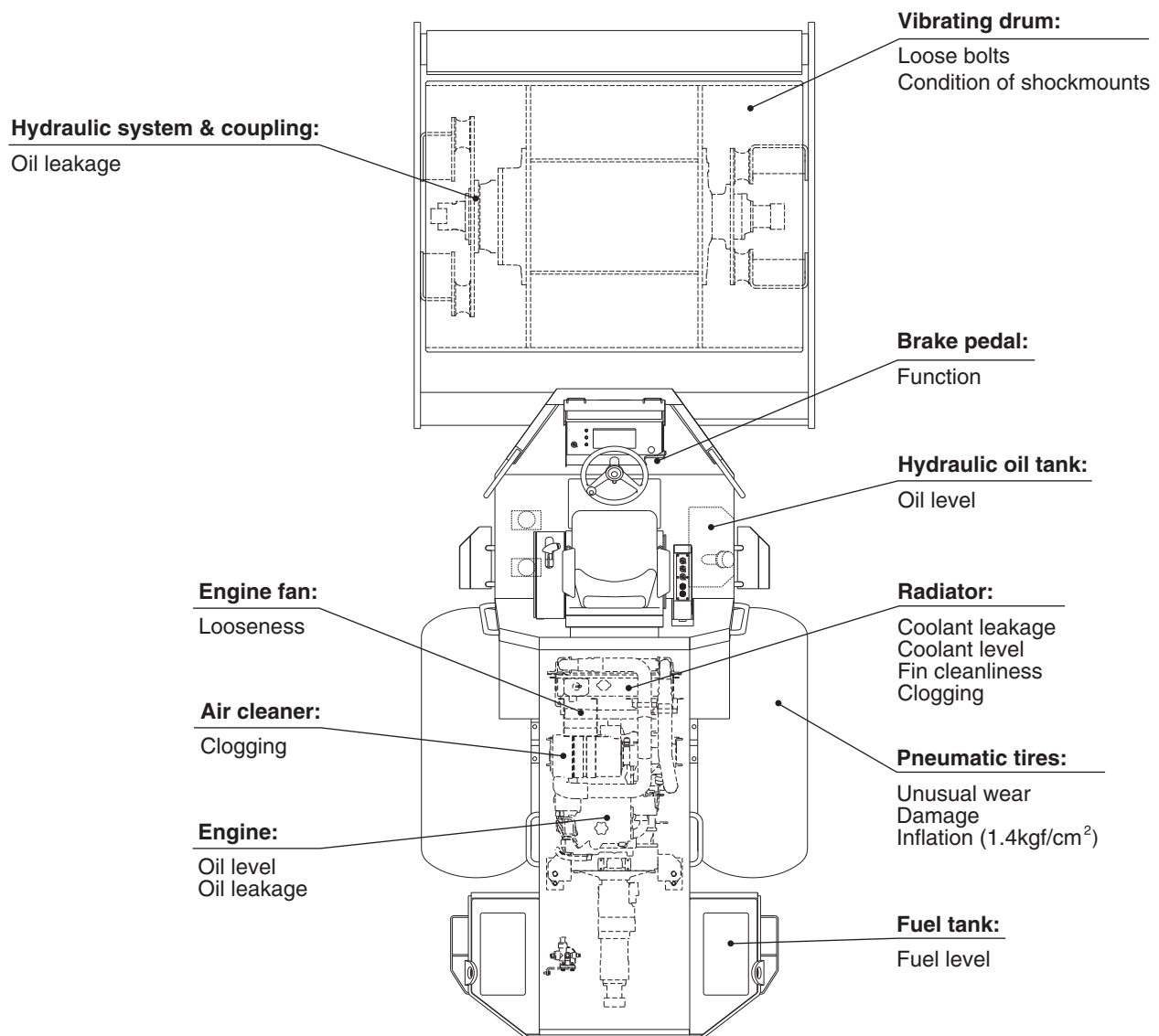

3. PERIODICAL MAINTENANCE

3.3 Periodical Maintenance Points

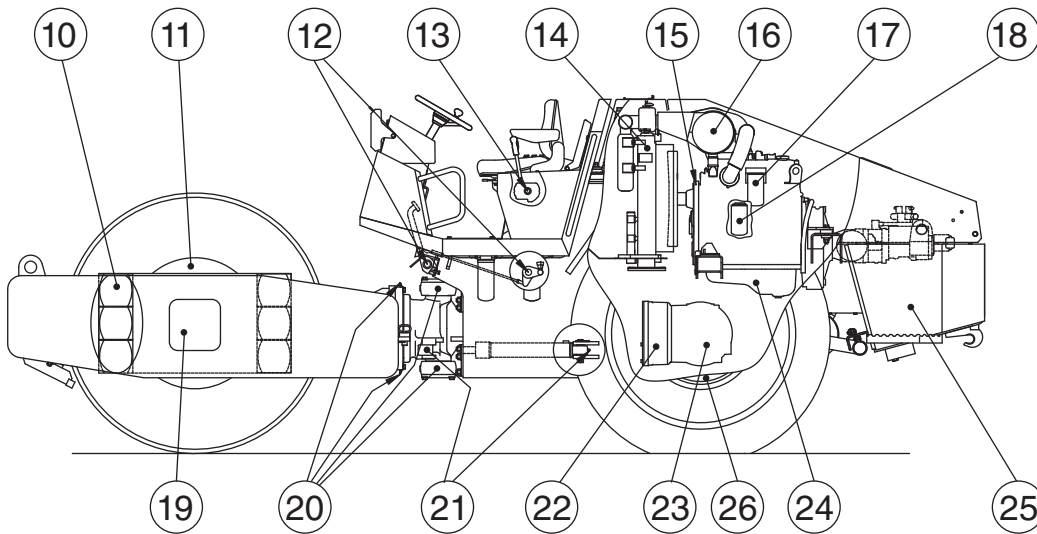
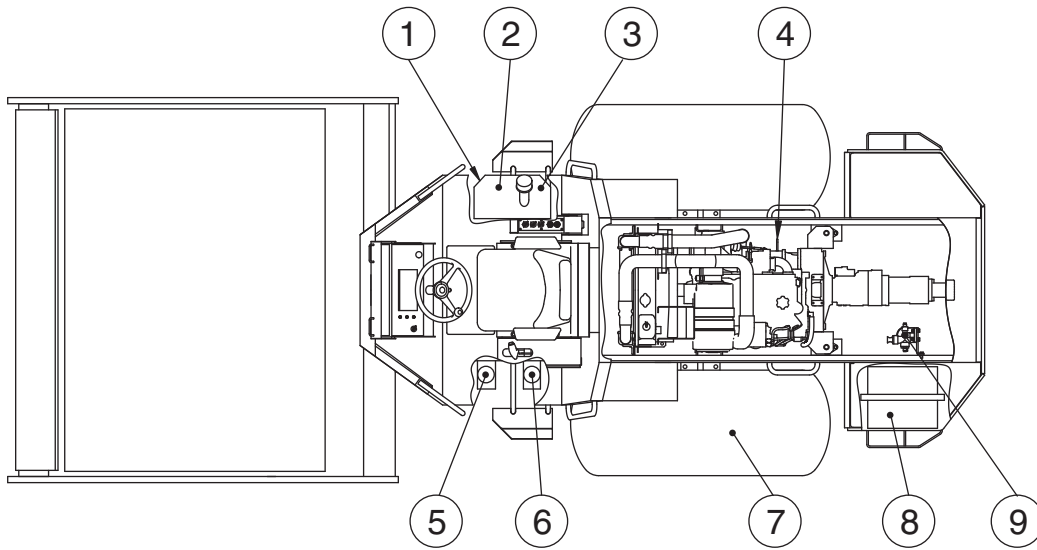

3. PERIODICAL MAINTENANCE

Interval	Sym- bol	Location	Inspection and service	Lubricant	Q'ty
Every 10 hours or daily	④	Engine oil level gauge	Check oil level, add as necessary	Engine oil	1
	⑭	Radiator	Check coolant level, add as necessary	Coolant	1
	⑮	Fan belt	Check tension and adjust		2
Every 50 hours	①	Hydraulic oil level gauge	Check oil level, add as necessary	Hydraulic oil	1
	⑧	Battery	Check fluid level, add as necessary	Battery fluid	1
	⑨	Fuel sedimenter	Check and remove water and sediment		1
	⑯	Air cleaner	Check indicator		1
Every 250 hours	⑦	Tires	Check condition and air pressure		2
	⑩	Rubber dampers	Check condition	Engine oil	—
	⑪	Vibrator	Check oil level	Gear oil	1
	⑫	Brake links	Apply grease	Grease	2
	⑱	Engine oil filter	Change element		1
	⑳	Center pin and tilt pin bearings	Apply grease	Grease	4
	㉑	Steering cylinder	Apply grease	Grease	4
	㉒	Transmission	Check oil level, add as necessary	Gear oil	1
	㉔	Engine oil pan	Change oil	Engine oil	1
㉖	Wheel hub nut	Check looseness		—	
Every 500 hours	⑤	Return filter	Change element		1
	⑥	Line filter	Change element		1
	⑬	Control links	Check looseness and adjust		1
	⑰	Fuel filter	Change element		1
	㉒	Transmission	Change oil	Gear oil	1
	㉓	Final drive/ Differential case	Change oil	Gear oil	3
Every 1000 hours	②	Suction filter	Clean element		1
	③	Hydraulic tank	Change oil	Hydraulic oil	1
	⑪	Vibrator	Change oil	Gear oil	1
	⑲	Gear case : Whell motor	Change oil	Gear oil	1
As required	⑯	Air cleaner	Clean or change element		1
	㉕	Fuel tank	Clean interior		1

3. PERIODICAL MAINTENANCE

3.4 Maintenance Procedure

➔ For servicing the engine, see the separate engine manual.

(1) Every 10 hours or daily

④ Engine oil level gauge

Shut down the engine and check the engine oil level. If it is not between MAX and MIN marks, add oil through the fill hole.

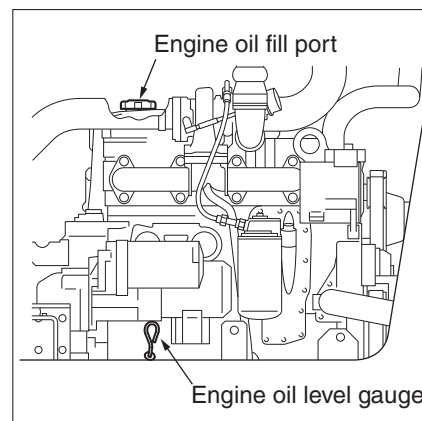

⑭ Radiator

Check to see coolant in sub-tank is up to level mark and replenish with water. Use soft water only.

⚠ CAUTION

- With radiator cap removed, feed water nearly up to filler port, then replenish the sub-tank as well.
- If level is below LOW mark, remove sub-tank cover and replenish with fresh water up to FULL mark.

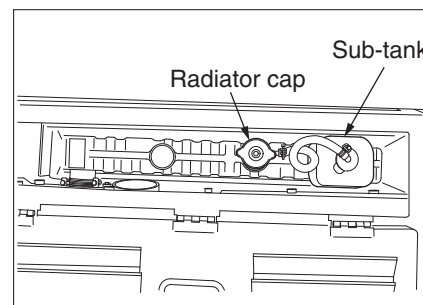

⚠ WARNING

Do not remove the radiator cap while the coolant is hot.



NOTE: Replace a coolant every two years.

3. PERIODICAL MAINTENANCE

⑮ Fan belt

Check the fan belt for wear and damage. Replace as necessary.

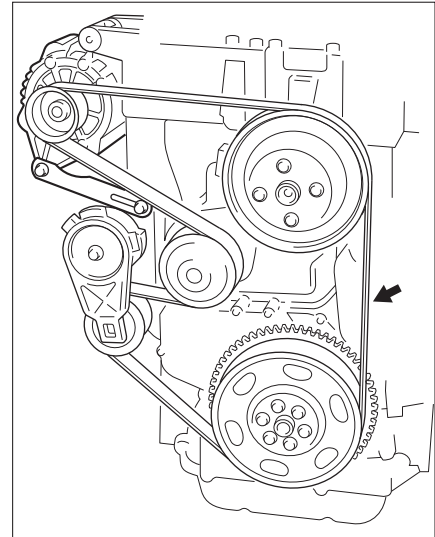

(2) Every 50 hours

① Hydraulic oil level gauge

Check the oil level with the sight glass on the side of tank. The level is proper if it is between H and L marks. Of necessary, add the hydraulic fluid from the fill port.

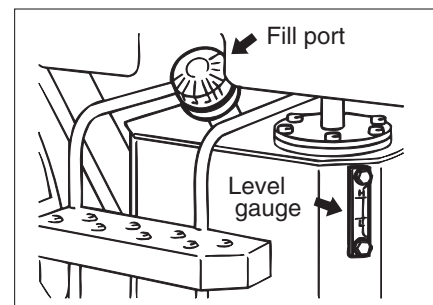

⑧ Battery

- 1) With the caps removed, check to see if the electrolyte level is above the plates.
- 2) Add distilled water or battery fluid commercially available if the level is too low.
- 3) Retighten any loose terminal. Apply grease or vaseline to the terminals to retard rusting.

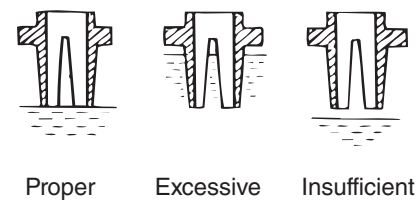

⚠ WARNING

Using or charging battery with electrolyte level below LOWER LEVEL mark on its side, could result in explosion. Continuing to use battery with insufficient electrolyte accelerates deterioration of the battery container internals. Be sure to have the electrolyte always replenished to the prescribed level.

3. PERIODICAL MAINTENANCE

⑨ Fuel sedimenter

Check the filter for water at regular intervals and drain as necessary.

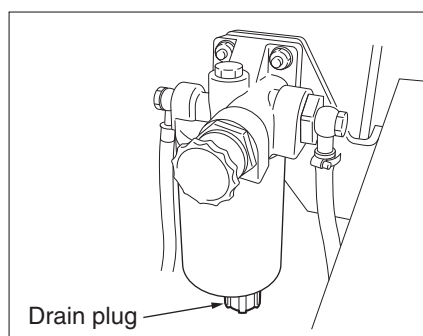
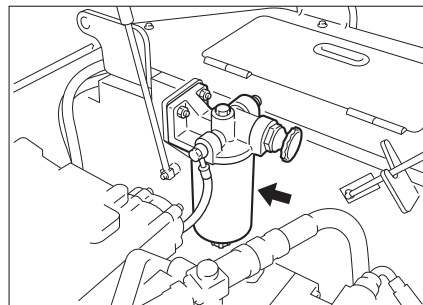

⑯ Air cleaner

When the red float of the dust indicator reaches the service level (a mark on the indicator), clean the element (see page 61).

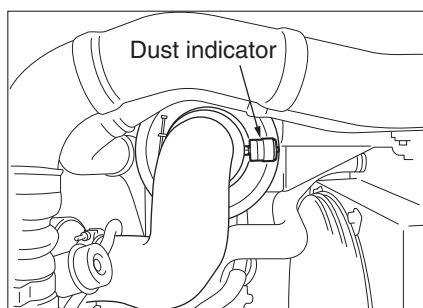

(3) Every 250 hours

⑦ Tires

- 1) Check for unusual wear and damage.
- 2) Check for the inflation. 137 kPa {1.4 kgf/cm²}
- 3) Check the wheel nuts for looseness.

⑩ Rubber dampers

Check the rubber blocks for cracks, and their mounting bolts for looseness.

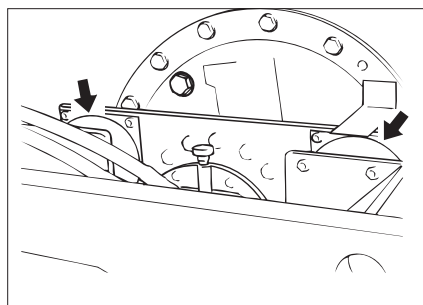

3. PERIODICAL MAINTENANCE

⑪ Vibrator

Check for the oil level and leakage.

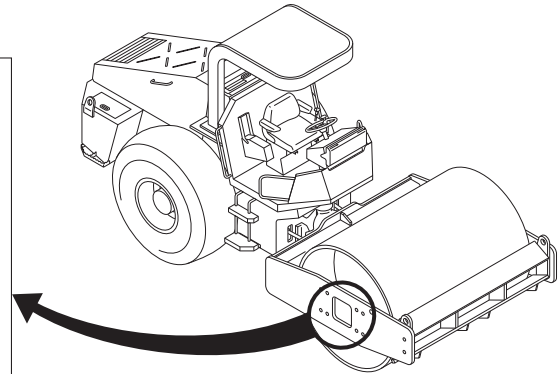
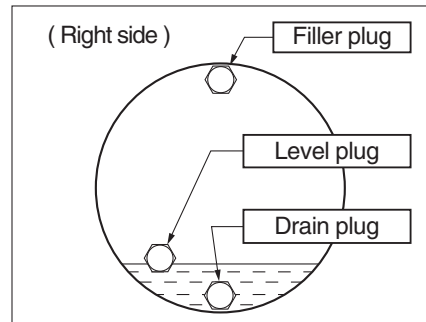

⑫ Brake links

Apply grease to the brake link bracket.

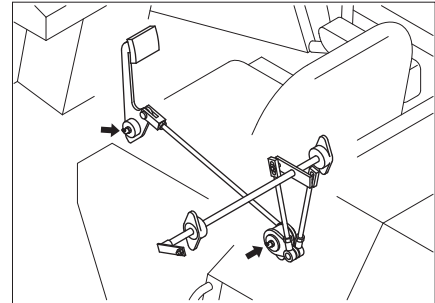

⑱ Engine oil filter

⑳ Engine oil pan

➔ See the separate engine manual.

- 1) After completion of operation and while the oil is warm, drain the oil with the drain plug ① removed.

⚠ WARNING

When draining a hot oil, use care not to get burned.

- 2) Refit the drain plug ① and fill the crankcase with the engine oil from the fill hole ② .
- 3) Change the oil filter ③ .

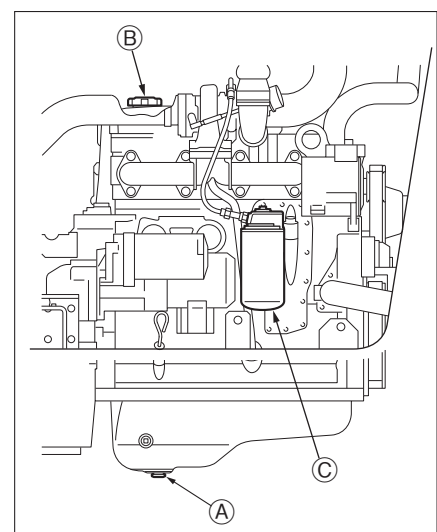

NOTE: For a new machine, change oil at 50 operating hours for the initial time only.

3. PERIODICAL MAINTENANCE

⑳ Center pin and tilt pin bearings

Apply grease at 4 locations.

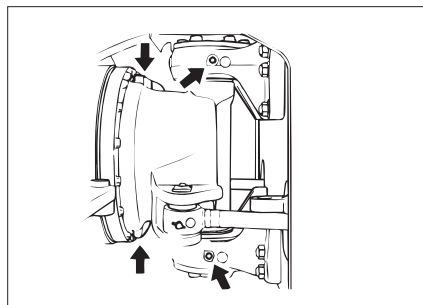

㉑ Steering cylinder

Apply grease at 4 locations.

The steering cylinder is provided on both sides of the machine.

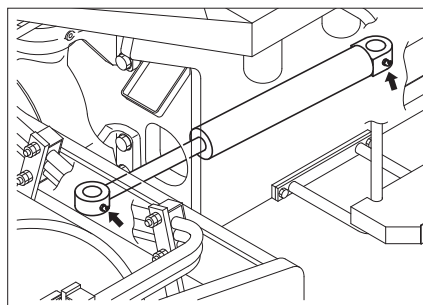

㉒ Transmission

Check for oil level, and add oil through the fill port as necessary.

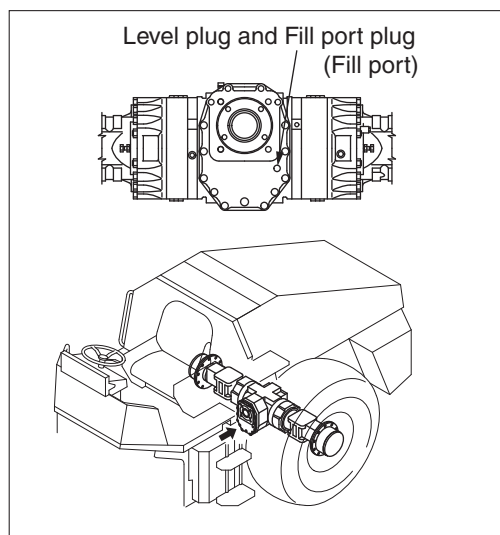

3. PERIODICAL MAINTENANCE

⑫ Wheel hub nut

Check the wheel hub nut for looseness. If it is loose, tighten it.
Be sure to torque it to the specified value.

Tightening torque: **630 N · m**

⚠ CAUTION

- Turn the wheel hub nut in the tightening direction during inspection.
- Excessive tightening of the wheel hub nut will lead to breakage of bolts or cracks in the disc wheel. Be sure to observe the specified torque.

NOTE: Tighten the wheel hub nut 50 hours after purchase of a new vehicle or replacement of tires.

(4) Every 500 hours

⑮ Return filter

⑯ Line filter

Change the elements.

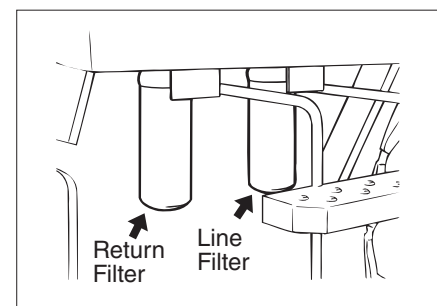

⑰ Control link

- 1) Check the nuts for looseness. Adjust the rod.
- 2) Apply grease to F-R lever shaft.

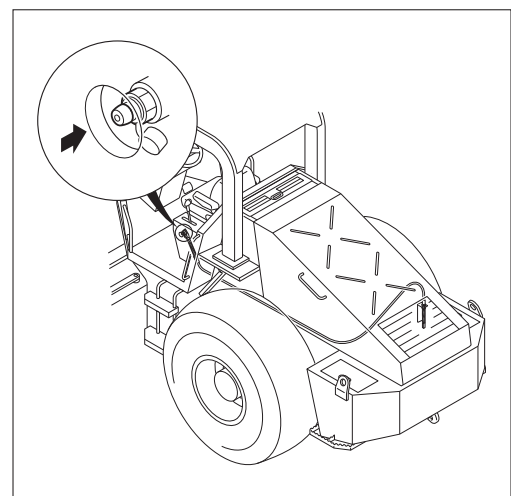

3. PERIODICAL MAINTENANCE

⑰ Fuel filter

➔ See the separate engine manual.

Change the filter cartridge.

⑳ Transmission

- 1) Drain the gear reducer oil by removing the drain plug.
- 2) Refit the drain plug.
- 3) Take off the level plug and fill port plug.
- 4) Fill oil through the fill port until oil starts overflowing from the level port.
- 5) Refit the level plug and fill port plug.

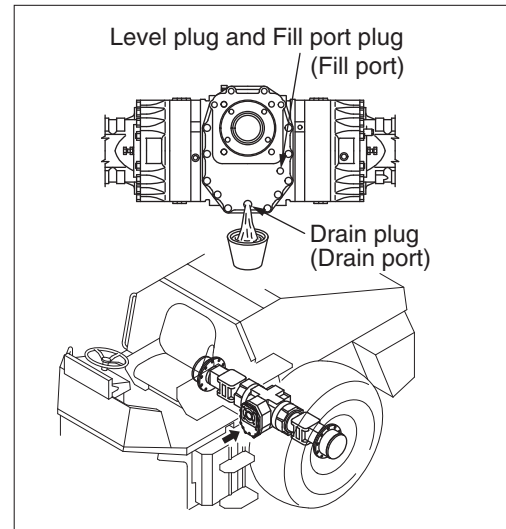

㉓ Final drive

- 1) Rotate the wheel till the drain port is located at the lowest position. Remove plug to drain oil.
- 2) At the final drive, adjust the position of plug until it is parallel to the ground.
- 3) Fill oil through the fill port till oil overflows from the level port.
- 4) When the final drive case is filled to the specified level, refit the removed plugs.

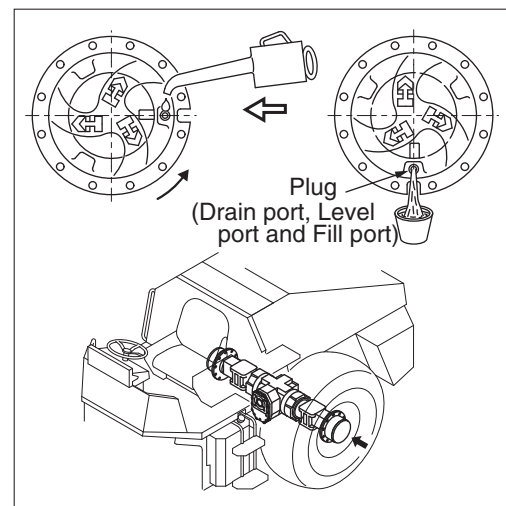

3. PERIODICAL MAINTENANCE

②③ Differential case

- 1) Drain oil by removing the drain plug, fill port plug and level plug.
- 2) Refit the drain plug.
- 3) Fill oil through the fill port till it overflows from the level port.
- 4) Refit the removed plugs.

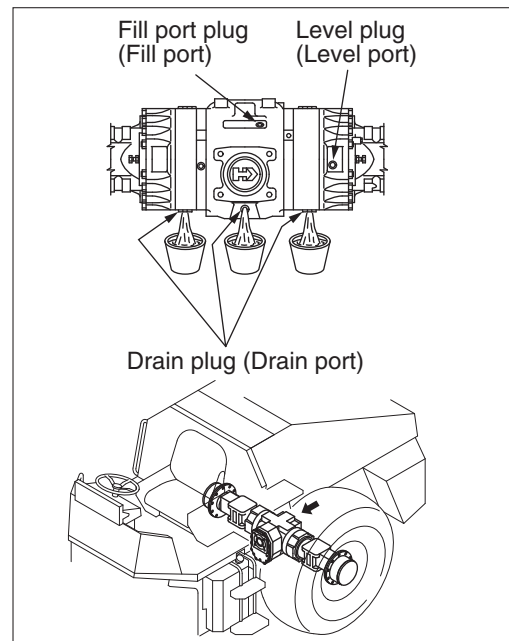

(5) Every 1,000 hours

② Suction filter

Take off the hydraulic tank cover. Take out and clean the strainer, change the strainer if necessary.

③ Hydraulic tank

- 1) Remove the drain plug, and drain oil while it is warm.
- 2) Clean inside of the tank, and fill fresh oil to the specified level.
- 3) Start and run the engine at idling for 2 to 5 minutes. When the hydraulic oil has become free from air bubbles, stop the engine and recheck the oil level.

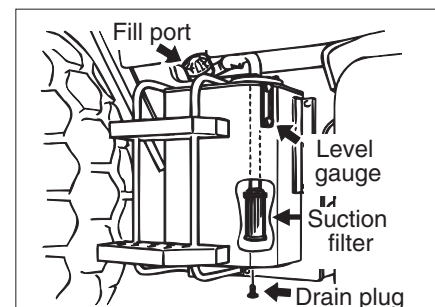

⚠ WARNING

When draining a hot oil, use care not to get burned.

3. PERIODICAL MAINTENANCE

⑪ Vibrator

- 1) Rotate the drum till the drain plug comes to bottom.
- 2) Remove drain plug, level gauge plug and filler plug.
- 3) Drain oil from vibrator.
- 4) Clean the vibrator before reinstalling it.
- 5) Feed oil at filler port until oil flows out of level gauge hole.
- 6) Reinstall the level gauge plug as well as filler plug after cleaning them.

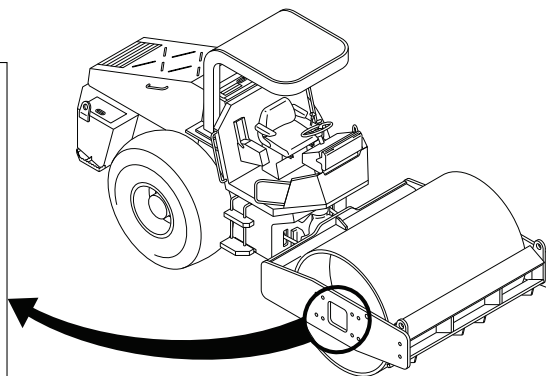
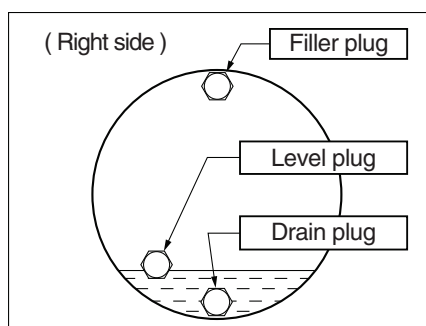

⚠ WARNING
When draining a hot oil, use care not to get burned.

⚠ CAUTION
The oil capacity of the vibrator is 40 liters. Do not fill more than 40 liters.

⑲ Gear case / Wheel motor

- 1) Position the drum so that the drain plug comes to the bottom.
- 2) Remove the drain plug and drain the oil while it is warm.
- 3) Rotate the drum so that a drain hole may come to top. Refit the drain plug and fill the oil through the fill hole until it overflows at the level hole.
- 4) Refit the level plug and drain plug.

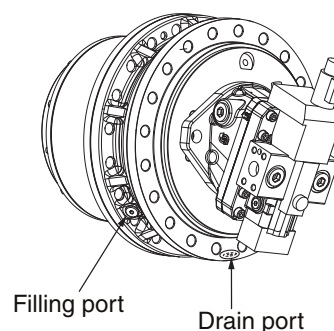

(6) As required

⑩ Air cleaner

When the red float of the dust indicator reaches the service level (a mark on the indicator), clean the element as described below:

- 1) Pull the clip and turn the cover 12 degrees counterclockwise to remove it. Withdraw the element.
- 2) Blow compressed air from inside of the element.

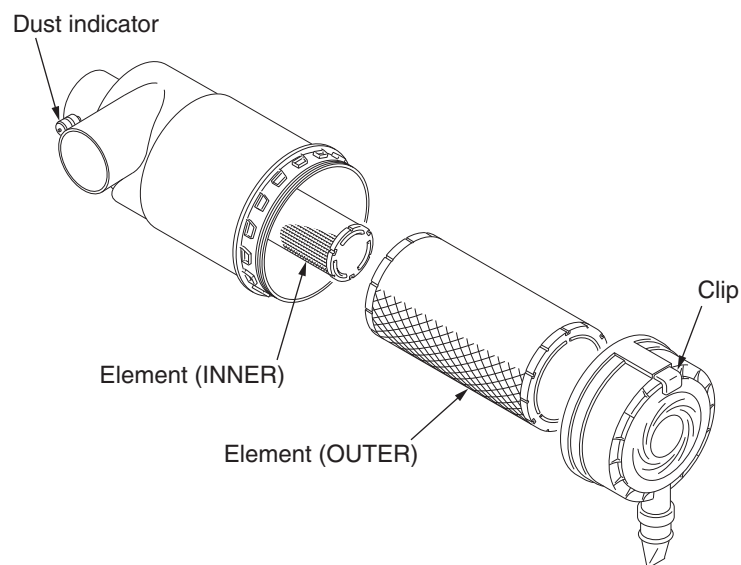

⚠ WARNING

Exercise caution not to get a speck of dust in your eye.

- 3) Check the element for any damage and replace as necessary, before pushing the dust indicator reset button.
- 4) Reinstall the element and fix the cover with the clip.
Turn the cover 12 degrees clockwise and push in the clip to fit it.

NOTE: In normal use, change the other element once in every six cleanings.

⚠ CAUTION

Replace the element when the red float reaches the service level even if it is cleaned.

3. PERIODICAL MAINTENANCE

25 Fuel tank

- 1) With the drain plug removed, remove the water and sediment from the bottom of the tank.
- 2) If sedimentation is substantial, remove the drain plug and clean the interior of the tank.
- 3) When the necessary work and refueling are complete, tighten the filler cap positively.

NOTE: When removing the water and sediment from the tank filled with the fuel, the fuel will gush out if the drain plug is screwed out completely.

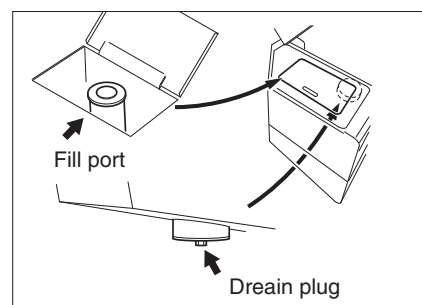

⚠ WARNING

- The fuel will catch fire if open flames or ignition sources are used close to it.
- Do not smoke or use a match or cigarette lighter close to it.



3.5 Feeding Water and Lubricants

1. General rules

- 1) Never feed water or lubricant with the strainer removed.
- 2) Use recommended lubricant and hydraulic fluid.
- 3) Do not use lubricants and hydraulic fluid of different brands.
- 4) When replacing oil, drain it completely and clean the container with flushing oil before filling new oil.
- 5) When fueling SAKAI machines, be sure to use the fuel that we specify or recommend.
Nonconformance resulting from use of fuel and lube oil other than those specified or recommended by our company is not covered by our warranty and repair service.

2. Capacity

Compartment	Type of fluid	Capacity in liters (gal.)
Fuel tank	Diesel oil	250 (66.0)
Engine oil pan	Engie oil	11.0 (2.9)
Hydraulic tank	Hydraulic oil	50 (13.2)
Gear case : Wheel motor	Gear oil	4.2 (1.1)
Radiator	Coolant	17.6 (4.6)
Vibrator	Gear oil	34 (9.0)
Transmission	Gear oil	2.0 (0.5)
Differential	Gear oil	9.5 (2.5)
Final drives	Gear oil	1.75 x 2 (0.5x 2)

3. Rating

Lubricant	Service classification	Ambient temp. and applicable viscosity rating			Applicable standards
		-15 ~ 30°C (5 ~ 86°F) Cold	0 ~ 40°C (32 ~ 104°F) Moderate	15 ~ 55°C (59 ~ 131°F) Tropical	
Engine oil	API grade CH-4	SAE 10W-30	SAE 15W-40	SAE 15W-40	MIL-L-2104B
Gear oil	API grade GL4	SAE 80W-90	SAE 90	SAE 140	MIL-L-2105
Hydraulic oil	Anti wear	ISO-VG32 over VI 140	ISO-VG46 over VI 140	ISO-VG68 over VI 110	ISO-3448
Grease	Lithium type extreme pressure				NLGI-2
Fuel	Diesel oil				ASTM D975-2D

3. PERIODICAL MAINTENANCE

4. Recommended lubricants

Lubricant Oil company	Engine oil API – CH – 4	Gear oil API GL 4	Hydraulic oil VG 46	Grease (NLGI - II)
CALTEX	—	Universal Thuban 90	Rando Oil HD 46	Martifack EP 2
BP	Vanellus C Extra	BP Gear Oil EP 90	BP Energol HLP 46	BP Energrease LS – EP 2
ESSO	—	Esso Gear Oil GP 90	Nuto H 46	Beacon EP 2
MOBIL	Delvac MX	Mobil Pegasus Gear Oil 90	Nuto Oil 25	Beacon EP 25
SHELL	Rimula X	Shell Spirax 90 EP	Shell Tellus Oil 46	Shell Alvania EP Grease 2
CASTROL	Castrol GTX Diesel	Castrol Hypoy 90	Hyspin AWS 46	Spherrol ELP 2

- CAUTION:** (1) Fill the fluid reservoirs with the filters installed.
 (2) Use recommended fuels and lubricants only.

3.6 Electric Wiring Diagram

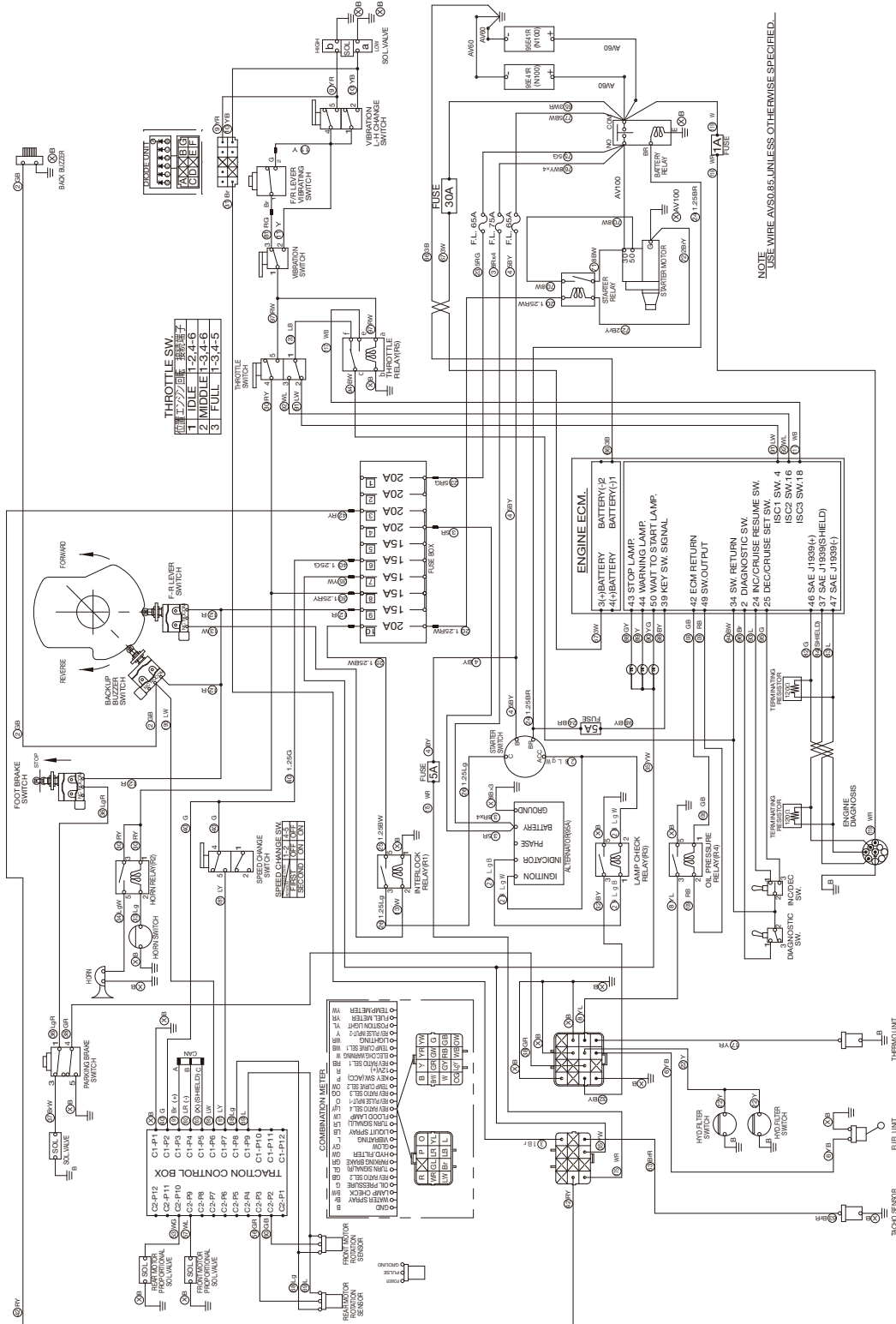

NOTE USE WIRE AWG/BS UNLESS OTHERWISE SPECIFIED.

CAUTION: Size of wires not indicated by letters are AV 0.85.

Color of wire	B	BR	BW	BY	Br	Brown/ Red stripe	BrR	GR	Green/ Red stripe	LR	Blue/ Red stripe	P	Pink	RW	Red/ White stripe	WR	White/ Red stripe	YR	Yellow/ Red stripe	LB	Blue/ Black stripe
	Black/ Red stripe	Black/ White stripe	Black/ Yellow stripe	Black/ Blue stripe	Brown	Brown/ White stripe	Brown/ White stripe	Green/ White stripe	Green/ White stripe	Blue/ White stripe	Blue/ White stripe	R	Red	RW	Red/ Yellow stripe	WR	White/ Red stripe	YR	Yellow/ White stripe	WG	White/ Green stripe
	Black/ White stripe	Black/ Yellow stripe	Black/ Blue stripe	Black/ Green stripe	Brown	Brown/ White stripe	Brown/ White stripe	Green/ Yellow stripe	Green/ Yellow stripe	Blue/ Yellow stripe	Blue/ Yellow stripe	RB	Red/ Black stripe	WB	White/ Black stripe	YG	Yellow/ Green stripe	BrY	Brown/ Yellow stripe	BG	Black/ Green stripe
	Black/ Yellow stripe	Black/ Blue stripe	Black/ Green stripe	Black/ Orange stripe	Brown	Brown/ White stripe	Brown/ White stripe	Green/ Light green	Green/ Light green	Blue/ Light green	Blue/ Light green	RG	Red/ Green stripe	WL	White/ Blue stripe	YL	Yellow/ Blue stripe	Sb	Blue	BG	Black/ Green stripe
	Black	Black/ Red stripe	Black/ White stripe	Black/ Yellow stripe	Brown	Brown/ White stripe	Brown/ White stripe	Green/ Blue	Green/ Blue	Blue/ Orange	Blue/ Orange	RL	Red/ Blue stripe	WL	White/ Blue stripe	YL	Yellow/ Blue stripe	Sb	Blue	BG	Black/ Green stripe

3. PERIODICAL MAINTENANCE

Fuse box

The fuse box houses five 15A-fuses and five 20A-fuses lined up with spares fitted for 15A- and 20A-fuses. Use fuses of correct capacity. See page 26.

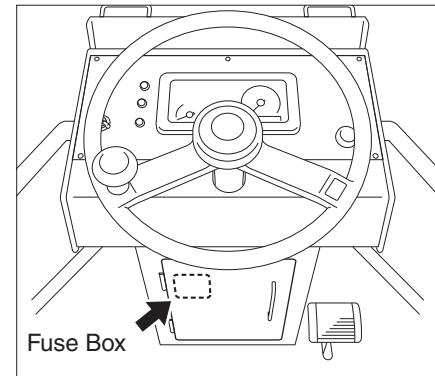

NOTE: When a fuse is burned, determine the cause before replacing.

Battery

- 1) Leaving the battery unused for long without attention or using its power excessively at a time can cause damage to the plates, leading to a shortened life.
- 2) For long-term storage, charge it fully, tighten the caps securely, store in a cool and dry place, and check the level of charge at least once a month.
- 3) Maintain the level of charge above 75%.
- 4) In cold weather, it is desirable to start the engine with the battery charged 100%. Do not try to start the engine with less than 75%.

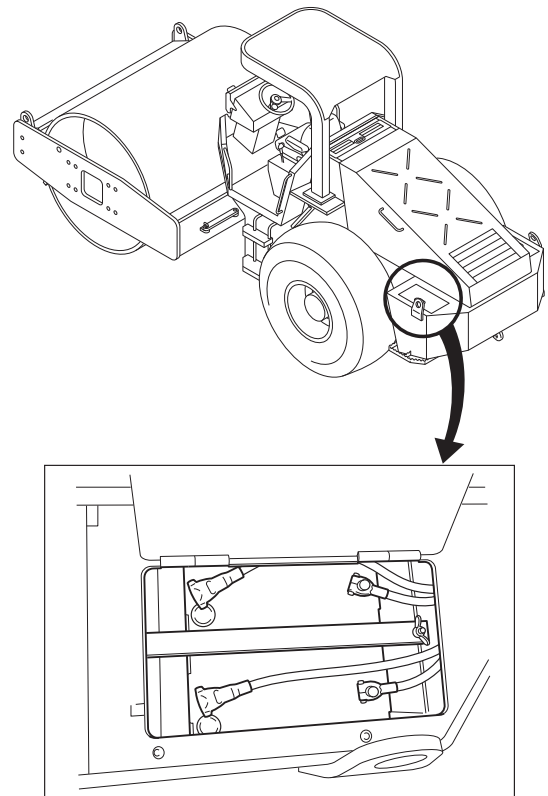

4 SPECIFICATIONS

(1) SV510D-III

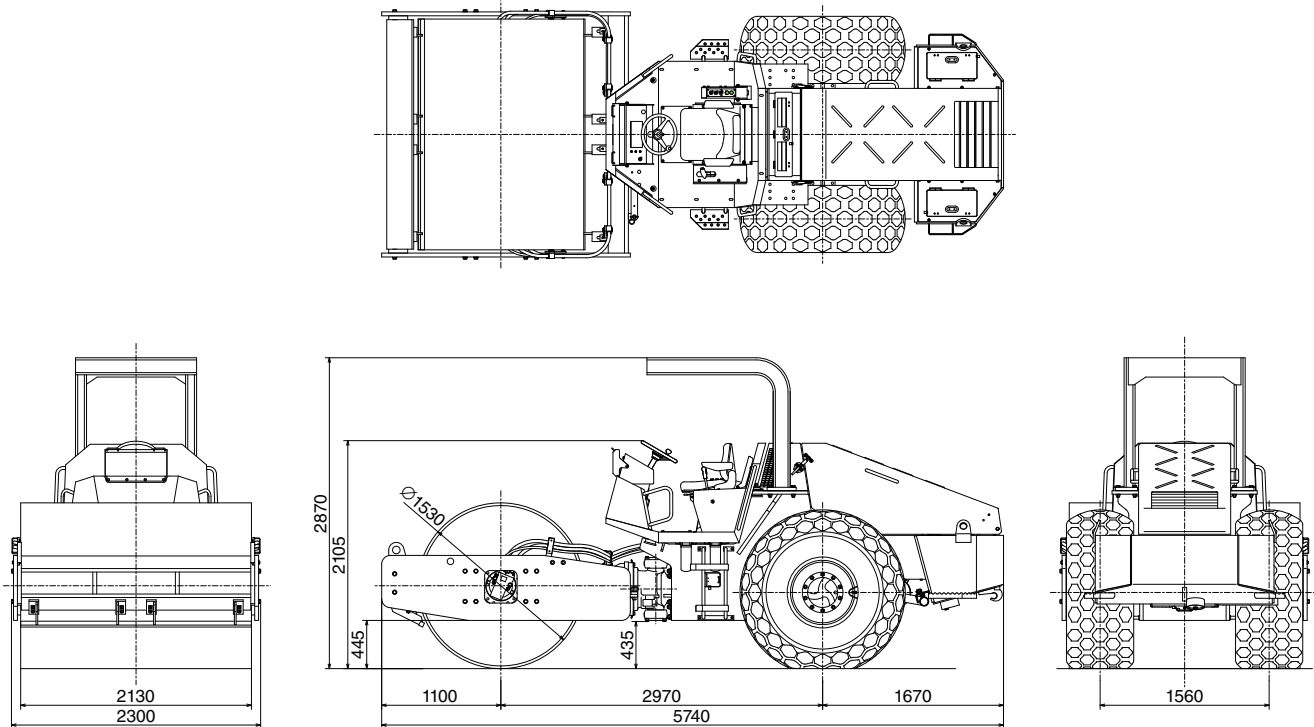

Model	SV510D-III		Vibrating power:	Low	High
Weight:			Frequency	36.7 Hz{2,200 vpm}	27.5 Hz{1,650 vpm}
Gross weight	10,670 kg (23,525 lbs)		Centrifugal force	172 kN(38,581 lbs)	226 kN(50,706 lbs)
On rear axle	5,760 kg (12,700 lbs)			{17,500kgf}	{23,000kgf}
On front axle	4,910 kg (10,825 lbs)		Gradability	62% (32°)	
Dimension:			Rolling width	2,130 mm (84")	
Overall length	5,740 mm (226")		Minimum turning radius	5.6 m (221")	
Overall width	2,300 mm (91")		Engine:		
Overall height	2,870 mm (111")		Model	CUMMINS QSB4.5 Tier-3 Diesel Engine with turbo charger	
Wheelbase	2,970 mm (117")		Total displacement	4.5 litres (274.6 cu.in)	
Wheel			Rated output	97 kW (132 ps)/2,300 min ⁻¹ (130 HP/2,100 rpm)	
Front	Roll (dia. x width) 1,530 x 2,130 mm (60" x 84")		Max. torque	511 N·m/1,500 min ⁻¹ (377 ft-lb/1,500 rpm)	
Rear	Tire 23.1-26-8 PR (OR)		Tank capacity:		
Performance:			Fuel tank	250 litres (66 gal)	
Travel speed			Hydraulic oil tank	50 litres (13 gal)	
	1st 0~6 km/h (0~3.7 mile/h)				
	2nd 0~10 km/h (0~6.2 mile/h)				

NOTE: Gradability is the calculated value. It may vary with ground surface conditions.

4. SPECIFICATIONS

(2) SV510T-III

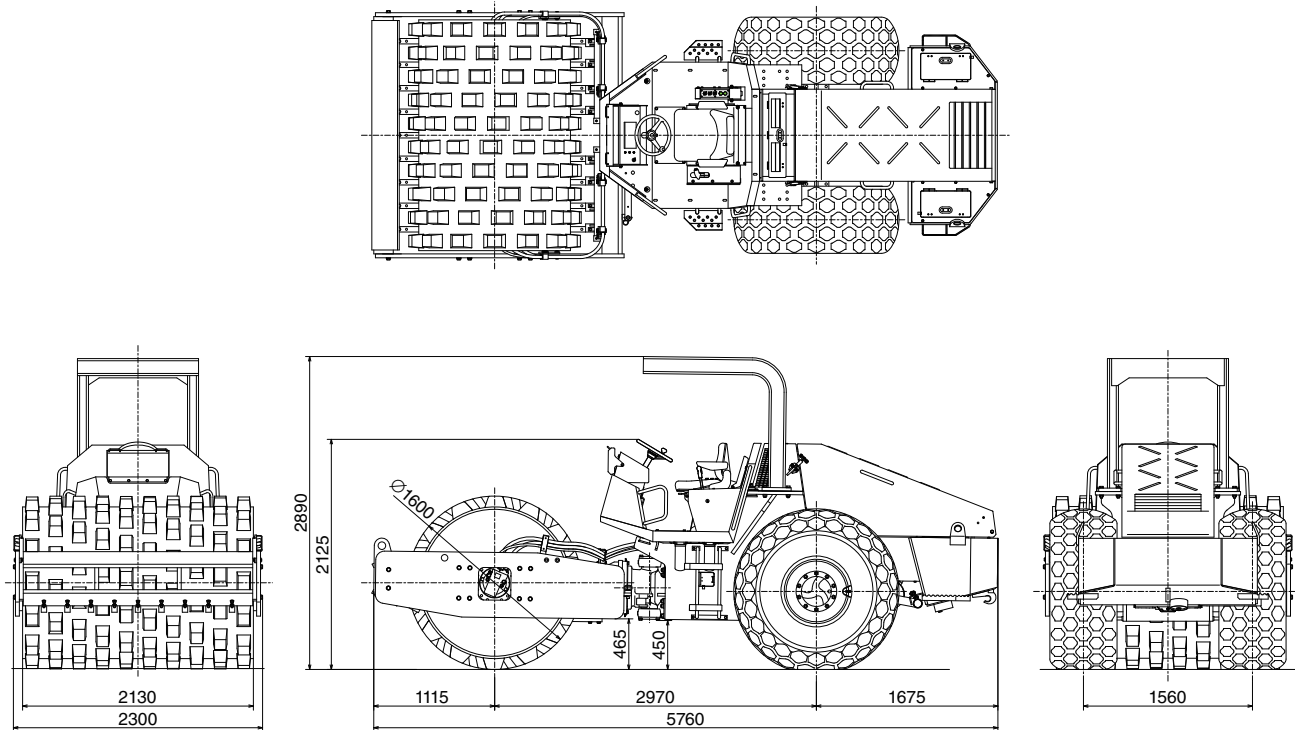

Model	SV510T-III		Vibrating power:	Low	High
Weight:			Frequency	36.7 Hz{2,200 vpm}	27.5 Hz{1,650 vpm}
Gross weight	11,030 kg (24,320 lbs)		Centrifugal force	186 kN(41,887 lbs)	245 kN(55,115 lbs)
On rear axle	6,110 kg (13,470 lbs)			{19,000kgf}	{25,000kgf}
On front axle	4,920 kg (10,850 lbs)		Gradability	62% (32°)	
Dimension:			Rolling width	2,130 mm (84")	
Overall length	5,760 mm (227")		Minimum turning radius	5.6 m (221")	
Overall width	2,300 mm (91")		Engine:		
Overall height	2,890 mm (111")		Model	CUMMINS QSB4.5 Tier-3 Diesel Engine with turbo charger	
Wheelbase	2,970 mm (117")		Total displacement	4.5 litres (274.6 cu.in)	
Wheel			Rated output	97 kW (132 ps)/2,300 min ⁻¹ (130 HP/2,300 rpm)	
Front	Roll (dia. x width)		Max. torque	511 N·m/1,500 min ⁻¹ (377 ft-lb/1,500 rpm)	
Pad	1,600 x 2,130 mm (63" x 84")		Tank capacity:		
Rear	Tire		Fuel tank	250 litres (66 gal)	
	23.1- 26 - 8 PR (OR)		Hydraulic oil tank	50 litres (13 gal)	
Performance:					
Travel speed					
	1st 0~6 km/h (0~3.7 mile/h)				
	2nd 0~10 km/h (0~6.2 mile/h)				

NOTE: Gradability is the calculated value. It may vary with ground surface conditions.

4. SPECIFICATIONS

(3) SV510TF-III

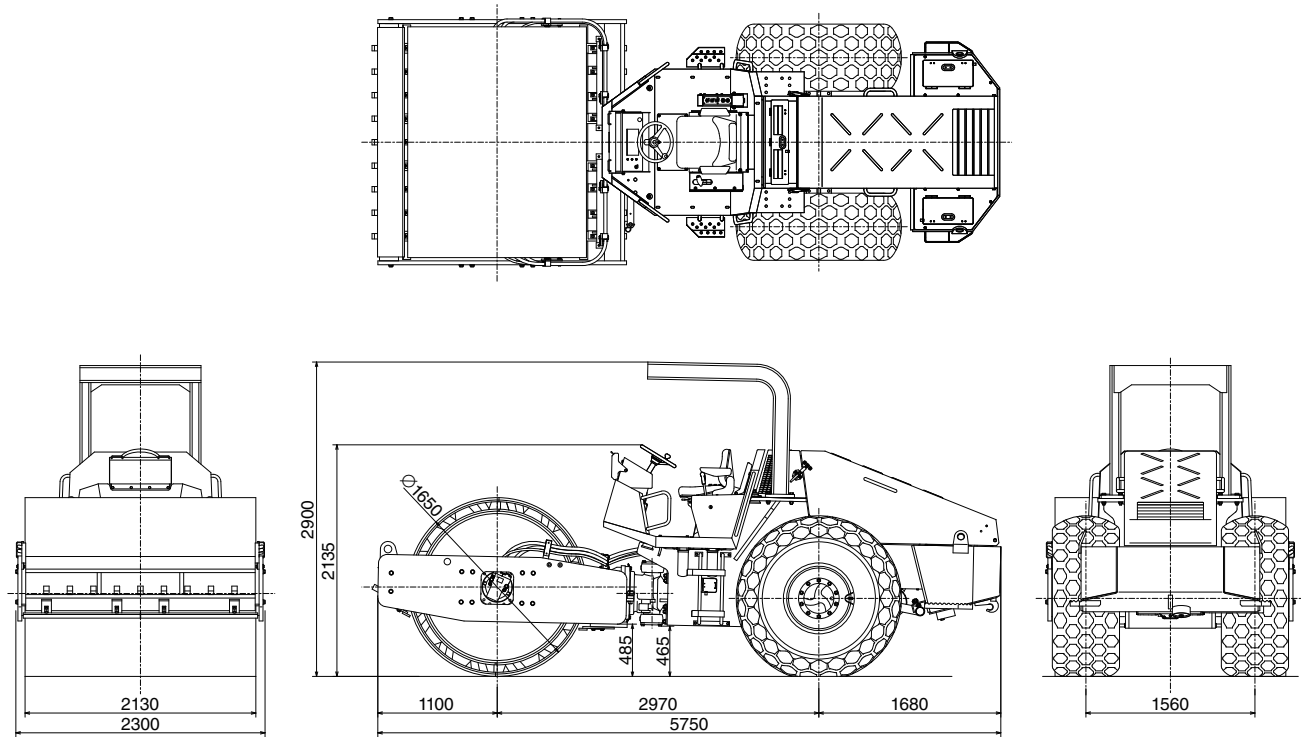

Model	SV510TF-III		Vibrating power:	Low	High
Weight:			Frequency	36.7 Hz{2,200 vpm}	27.5 Hz{1,650 vpm}
Gross weight	13,270 kg (29,255 lbs)		Centrifugal force	186 kN(41,887 lbs)	245 kN(55,115 lbs)
On rear axle	8,380 kg (18,475 lbs)			{19,000kgf}	{25,000kgf}
On front axle	4,890 kg (10,780 lbs)		Gradability	50% (27°)	
Dimension:			Rolling width	2,130 mm (84")	
Overall length	5,740 mm (226")		Minimum turning radius	5.6 m (221")	
Overall width	2,300 mm (91")		Engine:		
Overall height	2,900 mm (112")		Model	CUMMINS QSB4.5 Tier-3 Diesel Engine with turbo charger	
Wheelbase	2,970 mm (117")		Total displacement	4.5 litres (274.6 cu.in)	
Wheel			Rated output	97 kW (132 ps)/2,300 min ⁻¹ (130 HP/2,100 rpm)	
Front	Roll (dia. x width)		Max. torque	511 N·m/1,500 min ⁻¹ (377 ft-lb/1,500 rpm)	
Smooth	1,650 x 2,130 mm (65" x 84")				
Pad	1,600 x 2,130 mm (63" x 84")				
Rear	Tire				
	23.1- 26 - 8 PR (OR)				
Performance:			Tank capacity:		
Travel speed			Fuel tank	250 litres (66 gal)	
	1st 0~6 km/h (0~ 3.7 mile/h)		Hydraulic oil tank	50 litres (13 gal)	
	2nd 0~10 km/h (0~ 6.2 mile/h)				

NOTE: Gradability is the calculated value. It may vary with ground surface conditions.



SAKAI HEAVY INDUSTRIES, LTD.

Head Office: 1-4-8, Shiba Daimon, Minato-ku,
Tokyo, Japan

Telephone: Tokyo (03) 3431-9971

Facsimile: (03) 3436-6212

2013.07 ①©

