

SV510-II

SHOP MANUAL

SAKAI®

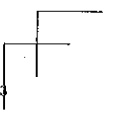

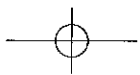
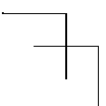
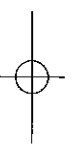
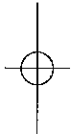
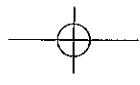
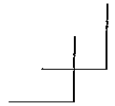

Introduction

This manual provides important information to familiarize you with safe operating and maintenance procedures for your SAKAI roller. Even though you may be familiar with similar equipment you must read and understand this manual before operating or servicing this unit.

Safety is everyone's business and it is one of your primary concerns. Knowing the guidelines presented in this manual will help provide for your safety, for the safety of those around you and for the proper operation and maintenance of the machine. Improper operation is dangerous and can result in injury or death.

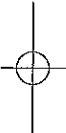

Sakai Heavy Industries cannot foresee all possible circumstances or varying conditions to which the operator, serviceman or machine may be exposed to that might lead to a potential hazard. Therefore, the warnings and cautions listed in this manual and those placed on the machine are not intended to be all inclusive and liability for personal injury or damage to equipment or property cannot be assumed.

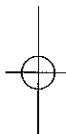

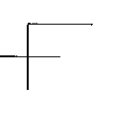
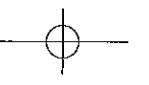
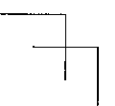
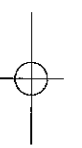
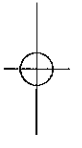
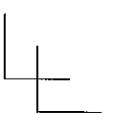
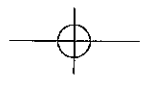
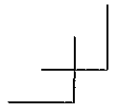

CONTENTS

1. SAFETY

| | |
|--|-------|
| 1. GENERAL SAFETY | 1-001 |
| 1-1. Understanding the Safety Symbols and Signal Words | 1-001 |
| 1-2. General | 1-001 |
| 1-3. Qualifications of Operators and Maintenance Personnel | 1-002 |
| 1-4. Safety Practices and Policies | 1-002 |
| 1-5. Pre Start Inspection | 1-003 |
| 1-6. Safety Instructions | 1-003 |
| 1-7. Starting | 1-004 |
| 1-8. Operating | 1-004 |
| 1-9. Stopping | 1-004 |
| 1-10. Maintenance | 1-005 |
| 1-11. Transporting the Machine | 1-007 |

2. SPECIFICATIONS

| | |
|--|-------|
| 1. SPECIFICATION DATA | 2-001 |
| 1-1. SV510D-II | 2-001 |
| 1-2. SV510T-II | 2-003 |
| 1-3. SV510TB-II | 2-005 |
| 1-4. SV510TF-II | 2-007 |
| 1-5. SV510TFB-II | 2-009 |
| 2. TABLE OF STANDARD VALUES | 2-011 |
| 2-1. Engine | 2-011 |
| 2-2. Drive device | 2-011 |
| 2-3. Hydraulic devices | 2-012 |
| 2-4. Steering devices | 2-012 |
| 2-5. Brakes | 2-013 |
| 2-6. Oil and grease capacity | 2-013 |
| 3. FUEL AND LUBRICANTS SPECIFICATION | 2-014 |
| 3-1. Rating | 2-014 |
| 3-2. Recommended lubricants | 2-014 |
| 4. TIGHTENING TORQUE CHART | 2-015 |

3. ENGINE AND CONTROLS

| | |
|-------------------------|-------|
| 1. ENGINE | 3-001 |
| 1-1. Engine mount | 3-001 |

| | |
|--------------------------------------|-------|
| 2. CONTROL SYSTEM | 3-002 |
| 2-1. Throttle control | 3-002 |
| 2-2. Forward-reverse control | 3-003 |
| 3. PUMP MOUNT | 3-004 |
| 3-1. Pump mount (SV510D/T/TF-Ⅱ) | 3-004 |
| 3-2. Pump attachment (SV510D/T/TF-Ⅱ) | 3-005 |
| 3-3. Pump mount (SV510TB/TFB-Ⅱ) | 3-007 |
| 3-4. Pump attachment (SV510TB/TFB-Ⅱ) | 3-008 |

4. HYDRAULIC SYSTEMS

| | |
|---|-------|
| 1. SYSTEM CIRCUIT DIAGRAM | 4-001 |
| 1-1. Graphic symbols for hydraulic | 4-001 |
| 1-2. Hydraulic circuit diagram (SV510D/T/TF-Ⅱ) | 4-003 |
| 1-3. Hydraulic circuit diagram (SV510TB/TFB-Ⅱ) | 4-004 |
| 2. PROPULSION HYDRAULIC SYSTEM | 4-005 |
| 2-1. Propulsion hydraulic piping (1) (front) | 4-005 |
| 2-2. Propulsion hydraulic piping (2) (rear) | 4-006 |
| 2-3. Hydraulic equipment specifications | 4-007 |
| 2-3-1. Propulsion pump (propulsion, vibrator, steering/charge) (SV510D/T/TF-Ⅱ) | 4-007 |
| 2-3-2. Propulsion pump (propulsion, vibrator, steering/charge) (SV510TB/TFB-Ⅱ) | 4-008 |
| 2-3-3. Propulsion hydraulic motor (front) | 4-009 |
| 2-3-4. Internal structure of propulsion hydraulic motor (front) | 4-010 |
| 2-3-5. Propulsion hydraulic motor (rear) | 4-011 |
| 2-3-6. Differential lock valve | 4-012 |
| 2-3-7. Manifold (for differential lock valve) | 4-013 |
| 2-3-8. Flow dividing valve | 4-014 |
| 2-3-9. Internal structure of flow dividing valve | 4-015 |
| 3. VIBRATOR HYDRAULIC SYSTEM | 4-016 |
| 3-1. Vibrator hydraulic piping | 4-016 |
| 3-2. Hydraulic equipment specifications | 4-017 |
| 3-2-1. Vibrator hydraulic motor | 4-017 |
| 4. STEERING SYSTEM | 4-018 |
| 4-1. Steering hydraulic piping (SV510D/T/TF-Ⅱ) | 4-018 |
| 4-2. Steering hydraulic piping (SV510TB/TFB-Ⅱ) | 4-019 |
| 4-3. Frame (center pin) | 4-020 |
| 4-4. Steering wheel | 4-021 |
| 4-4-1. Steering valve (Orbitrol) | 4-022 |

| | |
|--|-------|
| 4-5. Steering cylinder..... | 4-023 |
| 4-5-1. Internal structure of steering cylinder | 4-024 |
| 5. BLADE..... | 4-025 |
| 5-1. Blade hydraulic piping (SV510TB/TFB-II) | 4-025 |
| 5-2. Hydraulic equipment specifications | 4-026 |
| 5-2-1. Control valve | 4-026 |
| 5-2-2. Internal structure of cylinder | 4-027 |
| 5-2-3. Flow dividing valve | 4-028 |

5. ELECTRICAL SYSTEM

| | |
|---|-------|
| 1. GENERAL SYSTEM CIRCUIT DIAGRAM | 5-001 |
| 1-1. Electrical wiring diagram | 5-001 |
| 2. ELECTRICAL COMPONENTS | 5-002 |
| 2-1. Electrical component layout (1) | 5-002 |
| 2-2. Electrical component layout (2) | 5-003 |
| 2-3. Battery layout | 5-004 |
| 3. ELECTRICAL COMPONENT SPECIFICATIONS | 5-005 |
| 3-1. Fuse box | 5-005 |
| 3-2. Engine stop system | 5-006 |
| 3-2-1. Engine stopper functions and operation | 5-007 |
| 3-3. Diode unit | 5-009 |

6. VIBRATORY DRUM • REAR AXLE

| | |
|---|-------|
| 1. PRECAUTIONS FOR DISASSEMBLY AND REASSEMBLY | 6-001 |
| 2. VIBRATORY DRUM | 6-003 |
| 2-1. Removal and installation of vibratory drum | 6-003 |
| 2-1-1. Removal of vibratory drum | 6-003 |
| 2-1-2. Installation of vibratory drum | 6-006 |
| 2-2. Vibratory drum assembly | 6-007 |
| 2-3. Disassembly and reassembly of vibratory drum | 6-008 |
| 2-3-1. Disassembly of vibratory drum | 6-008 |
| 2-3-2. Reassembly of vibratory drum | 6-014 |
| 3. AXLE | 6-022 |
| 3-1. Rear axle | 6-022 |
| 3-2. Rear axle lubrication | 6-023 |
| 3-3. Rear axle structure..... | 6-024 |
| 3-3-1. Gearbox | 6-024 |
| 3-3-2. Center housing | 6-025 |
| 3-3-3. Differential | 6-026 |

| | |
|---------------------------------|-------|
| 3-3-4. Hub reduction gear | 6-027 |
| 3-3-5. Brake | 6-028 |

7. BRAKES

| | |
|---|-------|
| 1. BRAKE SYSTEM | 7-001 |
| 1-1. Brake pedal | 7-001 |
| 1-2. Brake circuit configuration | 7-002 |
| 1-3. Brake piping | 7-003 |
| 1-4. Brake solenoid valve | 7-004 |
| 2. BRAKE STRUCTURE | 7-005 |
| 3. BRAKE ADJUSTMENT | 7-006 |
| 3-1. Brake clearance adjustment | 7-006 |
| 3-2. Manually releasing the brake | 7-007 |

8. INSPECTION AND ADJUSTMENT

| | |
|--|-------|
| 1. INSPECTION AND ADJUSTMENT | 8-001 |
| 1-1. Inspection and Adjustment | 8-001 |
| 1-1-1. Safety precautions for inspection and adjustment | 8-001 |
| 1-1-2. Preparation for inspection and adjustment | 8-002 |
| 1-1-3. Precautions for inspection and adjustment | 8-002 |
| 1-1-4. Warm-up | 8-002 |
| 2. MEASUREMENT AND ADJUSTMENT OF PROPULSION CIRCUIT PRESSURE | 8-003 |
| 2-1. Measurement | 8-003 |
| 2-2. Adjustment | 8-004 |
| 3. MEASUREMENT AND ADJUSTMENT OF PROPULSION CHARGE CIRCUIT PRESSURE | 8-005 |
| 3-1. Measurement | 8-005 |
| 3-2. Adjustment | 8-006 |
| 4. MEASUREMENT OF VEHICLE HIGH/LOW-SPEED CHANGE CIRCUIT PRESSURE | 8-007 |
| 4-1. Measurement | 8-007 |
| 5. MEASUREMENT OF PARKING BRAKE RELEASE PRESSURE | 8-008 |
| 5-1. Measurement | 8-008 |
| 6. MEASUREMENT AND INSPECTION OF VIBRATOR CIRCUIT PRESSURE ... | 8-009 |
| 6-1. Measurement | 8-009 |
| 6-2. Inspection | 8-010 |
| 7. MEASUREMENT AND INSPECTION OF VIBRATION CHARGE CIRCUIT PRESSURE | 8-011 |

| | |
|--|-------|
| 7-1. Measurement | 8-011 |
| 7-2. Inspection | 8-012 |
| 8. MEASUREMENT AND INSPECTION OF STEERING CIRCUIT PRESSURE ... | 8-013 |
| 8-1. Measurement | 8-013 |
| 8-2. Inspection | 8-014 |
| 9. ADJUSTMENT OF THROTTLE LEVER LINKAGE | 8-015 |
| 9-1. Adjustment | 8-015 |
| 10. ADJUSTMENT OF FORWARD-REVERSE LEVER LINKAGE | 8-016 |
| 10-1. Adjustment | 8-016 |

9. TROUBLESHOOTING

| | |
|--|-------|
| 1. TROUBLESHOOTING | 9-001 |
| 1-1. Safety precautions for troubleshooting | 9-001 |
| 1-2. Important information for troubleshooting | 9-002 |
| 1-3. Before starting a troubleshooting session | 9-002 |
| 1-4. Wire color code | 9-002 |
| 2. FAULT DIAGNOSIS OF ELECTRICAL SYSTEM | 9-003 |
| 2-1. When performing electrical system fault diagnosis | 9-003 |
| 2-1-1. Precautions to take during electric circuit fault diagnosis | 9-003 |
| 2-1-2. Inspection of electrical system | 9-003 |
| 2-2. Engine | 9-007 |
| 2-2-1. Engine Will Not Start (Starter Motor Does Not Run) | 9-007 |
| 2-2-2. Engine Will Not Start (But Starter Motor Runs) | 9-009 |
| 2-2-3. Engine Does Not Stop Running | 9-009 |
| 2-2-4. No Charging | 9-011 |
| 2-2-5. Glow Plug Is Not Heated (Engine Starting Performance Is Bad) | 9-011 |
| 2-2-6. Starter Motor Runs Even Without Forward/Reverse Lever In Neutral ... | 9-011 |
| 2-3. Propulsion | 9-013 |
| 2-3-1. Vehicle Moves Neither Forward Nor Backward | 9-013 |
| 2-3-2. Differential Lock Does Not Function | 9-013 |
| 2-3-3. Dragging Of The Roll Occurs During Driving When The Differential Is Locked | 9-013 |
| 2-3-4. Vehicle Speed (Gear) Does Not Change | 9-015 |
| 2-3-5. Brake Does Not Release | 9-017 |
| 2-3-6. Brake Does Not Operate | 9-017 |
| 2-4. Vibrator | 9-019 |
| 2-4-1. No Vibration Occurs | 9-019 |
| 2-4-2. Amplitude Does Not Change (Remains Either Low or High) | 9-019 |
| 2-4-3. Vibrator Control Is Continuously Engaged Or | |

| | |
|--|-------|
| Does Not Change When The Forward/Reverse Lever Is Operated | 9-021 |
| 2-5. Lightings and accessories | 9-023 |
| 2-5-1. Combination Meter Monitor Lamps Do Not Light | 9-023 |
| 2-5-2. Tachometer Reading Is Abnormal | 9-023 |
| 2-5-3. Hour Meter Is Abnormal | 9-025 |
| 2-5-4. Temperature Gauge Is Abnormal | 9-025 |
| 2-5-5. Fuel Gauge Is Abnormal | 9-025 |
| 2-5-6. Hydraulic Oil Filter Warning Lamp Remains ON | 9-027 |
| 2-5-7. Oil Pressure Warning Lamp Remains ON | 9-027 |
| 2-5-8. Vibrator Operation Indicator Lamp Does Not Turn ON | 9-027 |
| 2-5-9. Parking Brake Indicator Lamp Does Not Light | 9-029 |
| 2-5-10. Horn Does Not Sound | 9-029 |
| 2-5-11. Backup Buzzer Does Not Beep | 9-031 |
| 3. HYDRAULIC SYSTEM TROUBLESHOOTING | 9-032 |
| 3-1. When performing hydraulic system troubleshooting | 9-032 |
| 3-2. Propulsion | 9-033 |
| 3-2-1. Vehicle Moves Neither Forward Nor Backward | 9-033 |
| 3-2-2. Vehicle Moves In One Direction Only (Forward Or Backward) | 9-034 |
| 3-2-3. Slow Vehicle Speed Or Small Drive Force | 9-034 |
| 3-2-4. Vehicle Speed Does Not Change | 9-035 |
| 3-2-5. Vehicle Does Not Stop Completely | |
| With Forward/Reverse Lever In Neutral Position | 9-035 |
| 3-2-6. Driving Not Possible With Differential Locked | 9-035 |
| 3-2-7. Propulsion System Is Overheating | 9-036 |
| 3-2-8. Abnormal Noise From Propulsion System | 9-036 |
| 3-3. Vibrator | 9-037 |
| 3-3-1. No Vibration | 9-037 |
| 3-3-2. Vibrator Frequency Is Too Low | 9-038 |
| 3-3-3. Vibrator L-h Does Not Switch | 9-038 |
| 3-3-4. Vibrator Does Not Stop | 9-038 |
| 3-3-5. Vibrator System Is Overheating | 9-039 |
| 3-3-6. Abnormal Noise From Vibrator System | 9-039 |
| 3-4. Steering | 9-040 |
| 3-4-1. Steering Wheel Is Hard To Turn | 9-040 |
| 3-4-2. Steering Response Is Slow | 9-040 |
| 3-4-3. Steering Wheel Backlash Or Play Is Large | 9-041 |
| 3-4-4. Steering System Is Overheating | 9-041 |
| 3-4-5. Abnormal Noise From Steering System | 9-041 |
| 3-5. Blade (SV510TB/TFB- II) | 9-042 |

| | |
|---|-------|
| 3-5-1. Blade Up/Down Operation Not Possible | 9-042 |
| 3-5-2. Blade Movement Is Slow Or Force Is Small | 9-042 |
| 3-5-3. Blade Floating Operation Not Possible | 9-043 |
| 3-5-4. Blade Hydraulic System Is Overheating | 9-043 |
| 3-5-5. Abnormal Noise From Blade Hydraulic System | 9-043 |

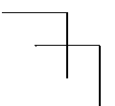
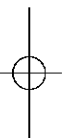
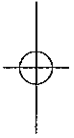
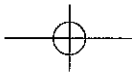
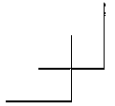

SAFETY

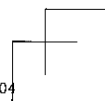
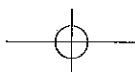
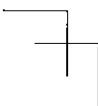
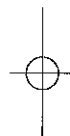
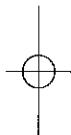
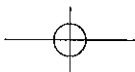
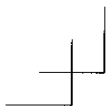



1. GENERAL SAFETY

1-1. Understanding the Safety Symbols and Signal Words

The words DANGER, WARNING, and CAUTION are used with the safety-alert symbol. DANGER identifies the most serious hazard. When the symbols DANGER, WARNING and CAUTION are displayed, become alert. Your safety or those around you may be involved. NOTICE is used to provide important information that is not hazard related.

 **DANGER:** Indicates an imminently hazardous situation or condition which if not avoided can result in serious personal injury or death.

 **WARNING:** Indicates a potentially hazardous situation or condition which if not avoided can result in serious personal injury or death.

 **CAUTION:** Indicates a potentially hazardous situation or condition which if not avoided may result in moderate personal injury or damage to the machine or personal property.

NOTICE: Indicates important information about operation or maintenance of the machine that may cause damage, breakdown, or shortened service life of the machine if you fail to observe.

: This signal means an important point to maintain of technology and quality in maintenance works.

 Items that indicate the weight of a part or equipment and require attention in wire selection and operating posture for slinging operation.

 In the assembly operation, tightening torque in locations that require particular attention.

1-2. General

- Operators and maintenance personnel must be alert to recognize and avoid potential hazards. They should also have comprehensive training, the required skills and necessary tools to perform the job safely.
- The machine was built in accordance to the latest safety standards and recognized safety rules. Nevertheless, misuse of the machine may result in risk to life and limb of the user or nearby personnel and may cause damage to the machine or other property.
- The machine must only be used for its intended purpose as described in the Operator's Manual. It must be operated by safety-conscious persons who are fully aware of the risks involved when operating the machine. Any malfunctions especially those affecting the safety of the machine must be corrected immediately.

GENERAL SAFETY

- The machine is designed specifically for the compaction of asphalt or soil road construction materials. Use of the machine for other purposes such as towing other equipment is considered contrary to the designated use. The manufacturer cannot be responsible or held liable for any damage resulting from such use. The risk for such use lies entirely with the user.
- Operating the machine within the limits of its designated use also involves compliance with the inspection and maintenance requirements contained in the Operation and Maintenance Manual.

1-3. Qualifications of Operators and Maintenance Personnel

- Work on the machine must be performed by qualified personnel only. Individual responsibilities of personnel regarding operation, maintenance, repair of the machine must be clearly stated.
- Define the operator's responsibilities; the operator should have authority to refuse instructions that are contrary to safety.
- Do not allow persons being trained to operate or perform maintenance on the machine without constant supervision by an experienced person.
- Work on the electrical system of the machine must be done only by an experienced person or under the guidance of a skilled electrician and according to electrical engineering rules and regulations.
- Work on the frame, brakes, hydraulic and steering systems must be performed by skilled personnel with special knowledge and training for such work.

1-4. Safety Practices and Policies

- Keep the manuals in the container provided on the machine. Manuals must always be available at the site where the machine is being used.
- The operator or user of the machine must be aware of all applicable or legal and mandatory regulations relevant to accident prevention and environmental protection. These regulations may also deal with handling of hazardous substances, the required proper personal safety and protective equipment and traffic or jobsite regulations.
- Machine operating instructions should also be supplemented with detailed instructions pertaining to the specific jobsite or work location.
- Always be sure the persons working on the machine have read the operating instructions and all safety precautions before beginning work. Reading safety instructions after work has already begun is too late.
- Wear close fitting garments and always tie back and secure long hair, also avoid wearing jewelry such as rings. Injury can result from loose clothing, hair or jewelry being caught up in the machinery or rotating parts.
- Use protective equipment as required by the circumstances or by law.



- Observe all safety instructions and warnings attached to the machine
- Make sure all safety instructions and warnings on the machine are complete and perfectly legible.
- Stop the machine immediately in the event of any malfunction. Report any malfunction immediately to the supervisor or other person of authority.
- Never perform service or maintenance on the machine unless the drum(s) or tires are adequately blocked, articulation lock bar and pin is in the locked position and the parking brake is applied.
- Never make any modifications to the machine which might affect safety without the manufacturer's approval.
- Always perform the recommended routine inspections and adjustments according to the prescribed intervals

1-5. Pre Start Inspection

- Inspect your machine daily. Ensure that the routine maintenance and lubrication are properly performed. Repair or replace any malfunctioning, broken or missing parts before using the machine. Refer to the maintenance schedule in the Operator's Manual.
- Check that all instructions and safety stickers are in place and readable.
- Never fill the fuel tank with the engine running or while near an open flame or while smoking.
- Always clean up any spilled fuel.
- Check for any warning tags placed on the machine, do not operate the machine until all repairs have been made and warning tags have been removed by authorized personnel.
- Check the seat belt for wear or damage; inspect the belt hardware and fabric. Replace if hardware is damaged or the belt is frayed or nicked or stitching is loose. Check that mounting hardware is tight.
- Clean the steps and operating platform of dirt and foreign matter to reduce danger of slipping.
- Know how to shut-down or stop the machine immediately in case of emergency.
- Know the capabilities and limitations of the machine such as speed, gradeability, steering and braking.
- Be aware of the dimensions of the machine such as height, weight especially for transporting.

1-6. Safety Instructions

- Take all necessary precautions to ensure that the machine is used only when in a safe and reliable condition.
- Avoid any operational mode that might compromise safety.
- Operate the machine only if all protective and safety devices are in place and fully functional.
- Always use the hand rails and steps to get on and off your machine maintaining 3-point contact (using both hands).

GENERAL SAFETY

1-7. Starting

- Start the machine only from the driver's seat and always wear the seat belt.
- Watch that the warning lights and indicators during start-up and shutdown are working in accordance with operating instructions.
- Watch that no one is in danger before starting and when moving the machine.
- Check that braking, steering, signals and lights are fully functional before starting work or traveling with the machine.

1-8. Operating

- Always make sure that there are no obstructions or persons in your line of travel before starting the compactor in motion.
- Never climb on and off the machine while it is in motion.
- Always remain seated with the seat belt fastened when traveling, compacting or loading or unloading the machine.
- Use caution and be very observant when operating in close quarters and congested areas.
- Obey all traffic regulations when working on public roads and make sure machine is compatible with these regulations.
- Never carry passengers.
- Know and use the hand signals for particular jobs and who has the responsibility for signaling.
- Do not work close to edges or in the vicinity of overhanging banks or on grades that could cause the compactor to slide or roll over. Avoid any areas that may be a risk to machine stability.
- Avoid side hill travel. Always operate up and down the slope. Always keep the propulsion (travel control) lever in low speed range when climbing or descending hills or steep grades.
- Make sure there is sufficient clearance when crossing underpasses, bridges and tunnels or when passing under overhead power lines.
- Never allow anyone to stand in the articulation area of the machine when the engine is running.
- Always look in all directions before reversing the direction of travel.
- Always switch on the lighting system (if equipped) during poor visibility conditions and after dark.
- Do not attempt to control the compactor travel speed with the throttle control. Maintain engine speed at the full operating RPM.
- Do not run the engine in a closed building for an extended period of time. Exhaust fumes can kill.

1-9. Stopping

- Always park the machine in a safe area on solid and level ground. If this is not possible, always park at a right angle to the slope and block the drum(s) or tires.
- Do not leave the operator's platform with the engine running. Always move the travel lever to neutral position and apply the parking brake then turn the ignition switch to OFF.
- Lock all lockable compartments.

- Park behind a safe barrier, use proper flags, and warning devices, especially when parking in areas of heavy traffic.

1-10. Maintenance

- In any performing any work concerning the operation, adjustment or modification of the machine or it's safety devices or any work related to maintenance, inspection or repair, always follow the start-up and shut-down procedures in the Operator's Manual and the Maintenance Manual.
- Ensure that the maintenance area is safe and secure.
- If the machine is shut down for maintenance or repair work it must be secured against inadvertent starting by removing the ignition key and attaching a warning sign to the ignition switch
- The machine must be parked on stable and level ground with the drum or tires blocked to prevent inadvertent movement.
- Immediately after the engine has stopped, the exhaust system, engine, radiator coolant, engine oil, hydraulic fluid and other lubricants and components will be very hot. Fluids can be under pressure, removing the radiator cap or draining oil or changing filters can cause serious burns. Wait until the machine has cooled down.
- Use care when attaching and securing lifting tackle to individual parts and large assemblies being removed or repositioned for repair purposes to avoid the risk of accident. Use lifting devices that are in perfect condition and of sufficient lifting capacity. Never stand under suspended loads.
- Always use the proper tools and workshop equipment in good condition when performing maintenance or repairs on the machine.
- Always use specially designed safety ladders and working platforms when working above floor level. Never use machine parts as a climbing aid.
- Keep all steps, handles, handrails, platforms and ladders free from mud, dirt, grease, ice or snow.
- Clean the machine, especially threaded connections of any traces of oil or fuel before carrying out any maintenance or repairs. Never use aggressive detergents. Use lint free cleaning rags.
- Examine all fuel, lubricant and hydraulic fluid lines and connectors for leaks, loose connections chafe marks or damage after cleaning.
- Repair or replace defective parts immediately.
- Whenever possible, avoid servicing or maintenance when the engine is running unless the drum and or tires are adequately blocked, the articulation lock bar is in the locked position and the parking brake is applied.



GENERAL SAFETY

- Never fill the fuel tank with the engine running, while near an open flame or while smoking. Always clean up any spilled fuel.
- Ensure safe operation, optimum performance of the machine and its warranty by using only genuine SAKAI replacement parts.
- Use only the specified fluids and lubricants. Substitute only products known to be equivalent from reputable manufacturers.
- Disconnect the battery cables when working on the electrical system or when welding on the compactor.
- Be sure the battery area is well ventilated (clear of fumes) should it be necessary to connect a jumper cable or battery charger. Fumes can ignite from a spark and may explode.
- Be sure battery charger is OFF when making connections if charging is required.
- Use only original fuses with the specified rating. Switch off the machine immediately if trouble occurs in the electrical system.
- Work on the electrical system may only be carried out by a qualified electrician or by a specially trained person according to electrical engineering principles.
- Inspect the electrical equipment of the machine at regular intervals. Defects such as loose connections or burnt or scorched wires must be repaired or replaced immediately.
- Do not weld, flame cut or perform grinding on the machine unless expressly authorized, as there may be a risk of fire or explosion. Disconnect the battery when welding on the machine.
- Clean the machine and its surrounding from dust or other flammable substances and make sure the area is adequately ventilated before beginning welding, flame cutting or grinding operations.
- Inspect hydraulic hoses at regular intervals and immediately replace if they show signs of chafing, cracking, brittleness, deformation, blistering, fitting separation, leakage, corrosion or other damage which may affect their function or strength.
- Do not work on hydraulic system while the engine is running and the system is under pressure. The hydraulic system remains pressurized even after the engine has stopped.
- Do not disconnect hydraulic hoses or fittings until the pressure has been properly relieved.
- Wait until the systems and fluid have cooled down before disconnecting.
- Never use your hands to check for leaks when inspecting a hydraulic system. Use a piece of cardboard and always wear gloves and safety glasses.



- Get immediate medical attention if fluid has been injected under your skin. Fluid penetration from a pin hole leak can cause severe injury or death.
- Ensure that hydraulic lines and hoses are routed and fitted properly. Ensure that no connections are interchanged. All fittings, lengths and specifications of hoses must comply with the technical requirements.

- Observe all product safety regulations when handling fuel, oils, grease, engine coolant and other chemical substances. Be careful especially when these items are hot as there is a risk of burning or scalding.
- Operate internal combustion engines and fuel operated heating systems only in adequately ventilated premises. Before starting the engine in an enclosed area, make sure there is sufficient ventilation.



1-11. Transporting the Machine

- Use only suitable and approved trailers and haul vehicles and lifting equipment of sufficient capacity.
- Entrust to experienced personnel the fastening and lifting of loads and instructing of crane operators.
- Only experienced persons familiar with the operation of the machine may load and unload the machine.
- Use ramps or a loading dock when loading or unloading the machine. Ramps must be the proper strength, low angle and the proper height and width.
- Block the wheels (front and rear) of the hauling vehicle when loading and unloading the compactor. Ensure that the haul vehicle is on level ground and approach the loading ramps squarely to make sure that the compactor does not slide off the edge of the ramp.
- Keep the deck clear of mud, oil, ice or snow or other materials that can make the deck slippery.
- Position the compactor on the trailer or transport vehicle centered from side to side, and apply the brake. Shut off the engine and lock all lockable compartments.
- Block the drums and lock the articulation lock bar. Chain the machine down properly using the appropriate tackle.
- Know the overall height of the compactor and hauling vehicle. Observe height and weight regulations and be sure you can pass safely at overhead obstructions.
- Obey all traffic regulations and be sure that the proper clearance flags, lights and warning signs including "Slow Moving Vehicle" emblem are displayed when traveling on public roads.
- Know the approximate stopping distance at any given speed.
- Drive Safely. Never turn corners at excessive speeds.

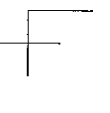
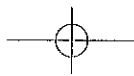
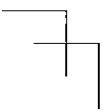
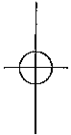
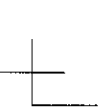
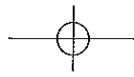
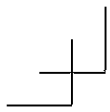

SPECIFICATIONS

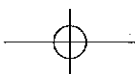
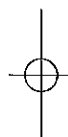
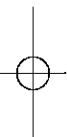
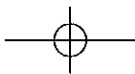
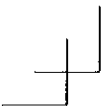

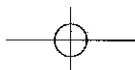
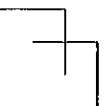
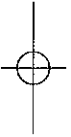
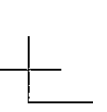
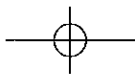
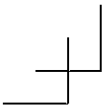

SPECIFICATION DATA

1. SPECIFICATION DATA

1-1. SV510D-II

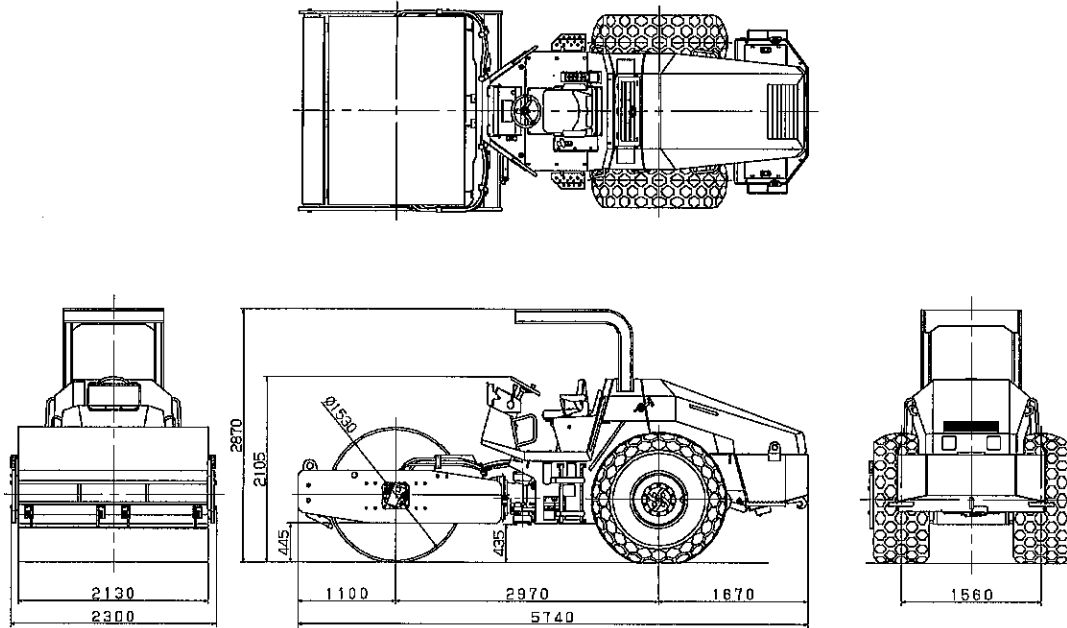

| | | | |
|------------------------|-----------------------------|-----------------|---------------------------|
| Model | | SV510D-II | |
| Weight | Operating weight | | 10,950 kg (24,140 lbs.) |
| | Front axle | | 5,820 kg (12,830 lbs.) |
| | Rear axle | | 5,130 kg (11,310 lbs.) |
| Dimensions | Overall length | | 5,740 mm (226 in.) |
| | Overall width | | 2,300 mm (91 in.) |
| | Overall height | | 2,870 mm (113 in.) |
| | Wheelbase | | 2,970 mm (117 in.) |
| | Minimum height above ground | | 435 mm (17 in.) |
| | Compaction width | | 2,130 mm (84 in.) |
| | Curve clearance | | 445 mm (17.5 in.) |
| Drive speed | 1 st | | 0 ~ 6 km/h (0 ~ 3.7 mph) |
| | 2 nd | | 0 ~ 10 km/h (0 ~ 6.2 mph) |
| Vibration performance | Vibration frequency | Low amplitude | 36.7 Hz |
| | | High amplitude | 27.5 Hz |
| | Centrifugal force | Low amplitude | 172 kN (38,580 lbf.) |
| | | High amplitude | 226 kN (50,710 lbf.) |
| | Amplitude | Low amplitude | 0.9 mm (0.04 in.) |
| | | High amplitude | 2.0 mm (0.08 in.) |
| Minimum turning radius | | 5.6 m (221 in.) | |
| Gradability*1 | | 62 % (32 °) | |

SPECIFICATION DATA

| | | | |
|----------------------|--|------------------------------|--|
| Engine | Name | | Isuzu BB-6BG1T diesel engine |
| | Model | | Water-cooled, 4-cycle, in-line, direct-injection, with turbocharger |
| | Number of cylinders - Bore x Stroke | | 6-105 mm × 125 mm (6-4.134 in. × 4.921 in.) |
| | Displacement | | 6,494 liters (396 cu.in.) |
| | Performance | Rated rotating speed | 2,000 min ⁻¹ (2,000 rpm) |
| | | Rated output | 103 kW (138 HP) |
| | | Maximum torque | 515 N·m (380 lbf·ft) at 1600 min ⁻¹ |
| | | Fuel consumption rate | 252 g/kW·h |
| | Fuel system | Fuel | Light oil JIS No. 2 or 3 equivalent |
| | | Speed governor | Mechanical all-speed type |
| | Lubrication system | Lubrication method | Forced circulation |
| | | Filtration method | Combination of full-flow/bypass |
| | Air purification system | | Dry type |
| | Cooling system | Cooling fan | Suction type |
| | | Radiator | Pressure type |
| Charging generator | | 24 V 50 A | |
| Starting motor | | 24 V 4.5 kW | |
| Battery | | 12 V 100 Ah x 2 units (24 V) | |
| Transmission device | Gearshift | Model | Hydrostatic transmission |
| | | Number of speeds | 2nd gear based on variable-capacity motor |
| | Reversing gear | | By conversion in direction of variable-capacity hydraulic pump's oil discharge |
| | Differential | | No-spin differential |
| Final reduction gear | | Planetary gear type | |
| Vibrator | Model | | Hydrostatic type |
| | Vibrating machine | Vibration method | Single-shaft eccentric/variable type (2nd gear variable by normal/reverse rotation of eccentric shaft) |
| | Installation location | | Front-wheel body interior |
| Braking device | Driving brake | | Hydrostatic brake, mechanical wet multiple-disc type |
| | Parking brake | | Mechanical wet multiple-disc type |
| Steering system | Steering control type | | Articulated fully hydraulic type |
| | Steering control angle | | ±37° |
| | Oscillation angle | | ±6.8° |
| Wheels | Front wheels (diameter x width) (vibration and driving wheels) | | 1,530 mm × 2,130 mm (60 in. × 84 in.) |
| | Rear wheels (size) (driving wheels) | | 23.1-26-8 PR (OR) |
| Other | Ropes | | Iron |
| | Electrical components and instruments | | 1 set |

•1: The gradability is the calculated value. It may vary based on the ground surface conditions.

SPECIFICATION DATA

1-2. SV510T-II

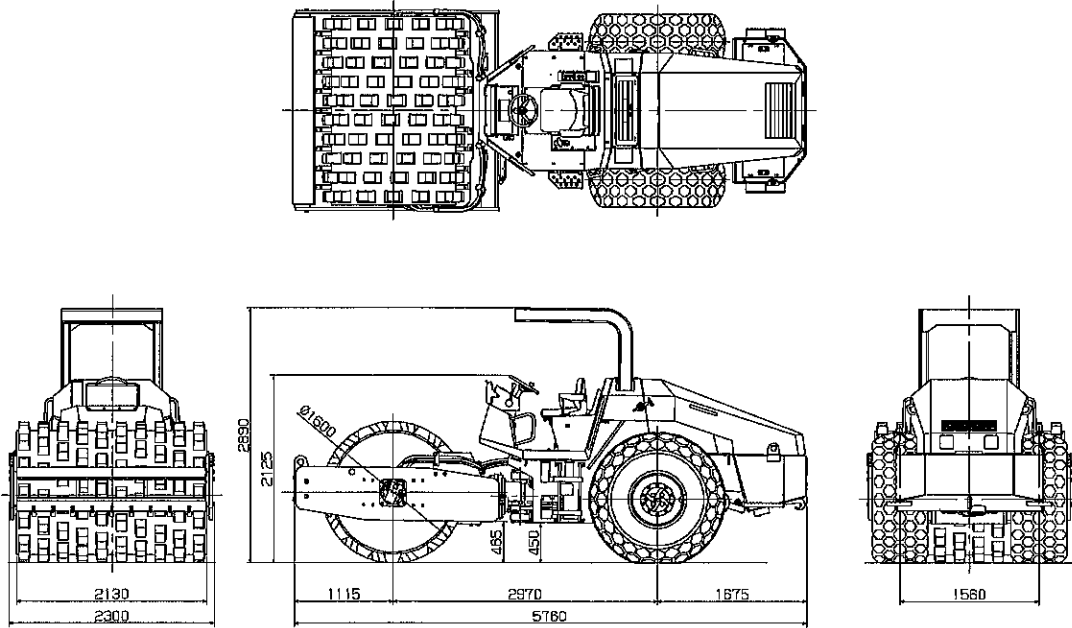

| | | | |
|------------------------|-----------------------------|----------------|---------------------------|
| Model | | SV510D-II | |
| Weight | Operating weight | | 11,320 kg (24,960 lbs.) |
| | Front axle | | 6,180 kg (13,630 lbs.) |
| | Rear axle | | 5,140 kg (11,330 lbs.) |
| Dimensions | Overall length | | 5,760 mm (227 in.) |
| | Overall width | | 2,300 mm (91 in.) |
| | Overall height | | 2,890 mm (114 in.) |
| | Wheelbase | | 2,970 mm (117 in.) |
| | Minimum height above ground | | 450 mm (17.5 in.) |
| | Compaction width | | 2,130 mm (84 in.) |
| | Curve clearance | | 465 mm (18.5 in.) |
| Drive speed | 1 st | | 0 ~ 6 km/h (0 ~ 3.7 mph) |
| | 2 nd | | 0 ~ 10 km/h (0 ~ 6.2 mph) |
| Vibration performance | Vibration frequency | Low amplitude | 36.7 Hz |
| | | High amplitude | 27.5 Hz |
| | Centrifugal force | Low amplitude | 186 kN (41,890 lbf.) |
| | | High amplitude | 245 kN (55,120 lbf.) |
| | Amplitude | Low amplitude | 0.9 mm (0.04 in.) |
| | | High amplitude | 2.0 mm (0.08 in.) |
| Minimum turning radius | | | 5.6 m (221 in.) |
| Gradability*1 | | | 62 % (32 °) |

SPECIFICATION DATA

| | | | | |
|----------------------|--|------------------------------|--|--|
| Engine | Name | | Isuzu BB-6BG1T diesel engine | |
| | Model | | Water-cooled, 4-cycle, in-line, direct-injection, with turbocharger | |
| | Number of cylinders - Bore x Stroke | | 6-105 mm × 125 mm (6-4.134 in. × 4.921 in.) | |
| | Displacement | | 6,494 liters (396 cu.in.) | |
| | Performance | Rated rotating speed | 2,000 min ⁻¹ (2,000 rpm) | |
| | | Rated output | 103 kW (138 HP) | |
| | | Maximum torque | 515 N·m (380 lbf·ft) at 1600 min ⁻¹ | |
| | | Fuel consumption rate | 252 g/kW·h | |
| | Fuel system | Fuel | Light oil JIS No. 2 or 3 equivalent | |
| | | Speed governor | Mechanical all-speed type | |
| | Lubrication system | Lubrication method | Forced circulation | |
| | | Filtration method | Combination of full-flow/bypass | |
| | Air purification system | | Dry type | |
| | Cooling system | Cooling fan | Suction type | |
| | | Radiator | Pressure type | |
| | Charging generator | | 24 V 50 A | |
| Starting motor | | 24 V 4.5 kW | | |
| Battery | | 12 V 100 Ah x 2 units (24 V) | | |
| Transmission device | Gearshift | Model | Hydrostatic transmission | |
| | | Number of speeds | 2nd gear based on variable-capacity motor | |
| | Reversing gear | | By conversion in direction of variable-capacity hydraulic pump's oil discharge | |
| | Differential | | No-spin differential | |
| Final reduction gear | | Planetary gear type | | |
| Vibrator | Model | | Hydrostatic type | |
| | Vibrating machine | Vibration method | Single-shaft eccentric/variable type (2nd gear variable by normal/reverse rotation of eccentric shaft) | |
| | Installation location | | Front-wheel body interior | |
| Braking device | Driving brake | | Hydrostatic brake, mechanical wet multiple-disc type | |
| | Parking brake | | Mechanical wet multiple-disc type | |
| Steering system | Steering control type | | Articulated fully hydraulic type | |
| | Steering control angle | | ±37° | |
| | Oscillation angle | | ±6.8° | |
| Wheels | Front wheels (diameter x width) (vibration and driving wheels) | | 1,600 mm × 2,130 mm (63 in. × 84 in.) | |
| | Rear wheels (size) (driving wheels) | | 23.1-26-8 PR (OR) | |
| Other | Ropes | | Iron | |
| | Electrical components and instruments | | 1 set | |

•1: The gradability is the calculated value. It may vary based on the ground surface conditions.

SPECIFICATION DATA

1-3. SV510TB-II

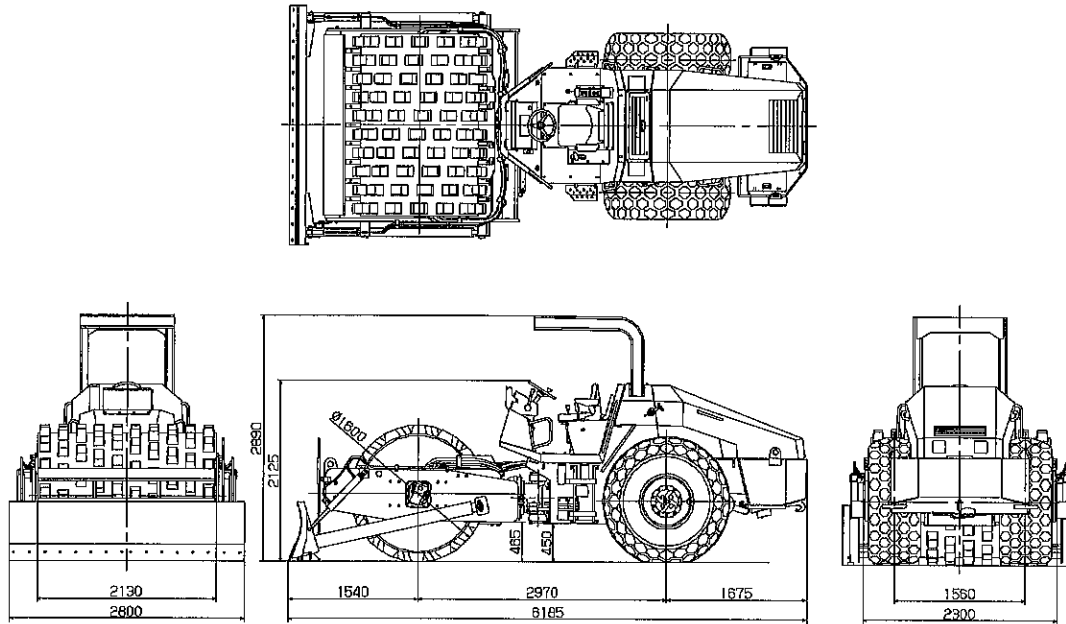

| | | | |
|--------------------------|-----------------------------|----------------|---------------------------|
| Model | | SV510TB-II | |
| Weight | Operating weight | | 11,800 kg (26,015 lbs.) |
| | Front axle | | 6,750 kg (14,880 lbs.) |
| | Rear axle | | 5,050 kg (11,135 lbs.) |
| Dimensions | Overall length | | 6,185 mm (244 in.) |
| | Overall width | | 2,800 mm (110 in.) |
| | Overall height | | 2,890 mm (114 in.) |
| | Wheelbase | | 2,970 mm (117 in.) |
| | Minimum height above ground | | 450 mm (17.5 in.) |
| | Compaction width | | 2,130 mm (84 in.) |
| | Curve clearance | | 465 mm (18.5 in.) |
| Drive speed | 1 st | | 0 ~ 6 km/h (0 ~ 3.7 mph) |
| | 2 nd | | 0 ~ 10 km/h (0 ~ 6.2 mph) |
| Vibration performance | Vibration frequency | Low amplitude | 36.7 Hz |
| | | High amplitude | 27.5 Hz |
| | Centrifugal force | Low amplitude | 186 kN (41,890 lbf.) |
| | | High amplitude | 245 kN (55,120 lbf.) |
| | Amplitude | Low amplitude | 0.9 mm (0.04 in.) |
| | | High amplitude | 2.0 mm (0.08 in.) |
| Minimum turning radius | | | 5.6 m (221 in.) |
| Gradability ¹ | | | 62 % (32 °) |

SPECIFICATION DATA

| | | | |
|----------------------|--|------------------------------|--|
| Engine | Name | | Isuzu BB-6BG1T diesel engine |
| | Model | | Water-cooled, 4-cycle, in-line, direct-injection, with turbocharger |
| | Number of cylinders - Bore x Stroke | | 6-105 mm X 125 mm (6-4.134 in. X 4.921 in.) |
| | Displacement | | 6,494 liters (396 cu.in.) |
| | Performance | Rated rotating speed | 2,000 min ⁻¹ (2,000 rpm) |
| | | Rated output | 103 kW (138 HP) |
| | | Maximum torque | 515 N·m (380 lbf·ft) at 1600 min ⁻¹ |
| | | Fuel consumption rate | 252 g/kW·h |
| | Fuel system | Fuel | Light oil JIS No. 2 or 3 equivalent |
| | | Speed governor | Mechanical all-speed type |
| | Lubrication system | Lubrication method | Forced circulation |
| | | Filtration method | Combination of full-flow/bypass |
| | Air purification system | | Dry type |
| | Cooling system | Cooling fan | Suction type |
| | | Radiator | Pressure type |
| Charging generator | | 24 V 50 A | |
| Starting motor | | 24 V 4.5 kW | |
| Battery | | 12 V 100 Ah x 2 units (24 V) | |
| Transmission device | Gearshift | Model | Hydrostatic transmission |
| | | Number of speeds | 2nd gear based on variable-capacity motor |
| | Reversing gear | | By conversion in direction of variable-capacity hydraulic pump's oil discharge |
| | Differential | | No-spin differential |
| Final reduction gear | | Planetary gear type | |
| Vibrator | Model | | Hydrostatic type |
| | Vibrating machine | Vibration method | Single-shaft eccentric/variable type (2nd gear variable by normal/reverse rotation of eccentric shaft) |
| | Installation location | | Front-wheel body interior |
| Braking device | Driving brake | | Hydrostatic brake, mechanical wet multiple-disc type |
| | Parking brake | | Mechanical wet multiple-disc type |
| Steering system | Steering control type | | Articulated fully hydraulic type |
| | Steering control angle | | ±37° |
| | Oscillation angle | | ±6.8° |
| Wheels | Front wheels (diameter x width) (vibration and driving wheels) | | 1,600 mm X 2,130 mm (63 in. X 84 in.) |
| | Rear wheels (size) (driving wheels) | | 23.1-26-8 PR (OR) |
| Other | Ropes | | Iron |
| | Electrical components and instruments | | 1 set |

•1: The gradability is the calculated value. It may vary based on the ground surface conditions.

SPECIFICATION DATA

1-4. SV510TF-II

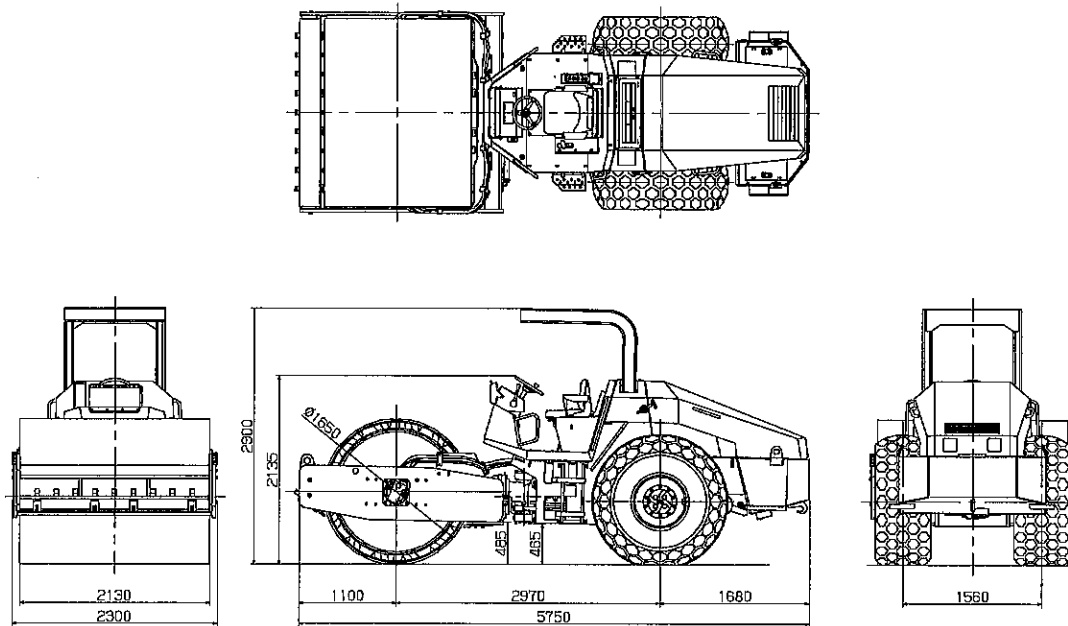

| | | | |
|------------------------|-----------------------------|----------------|---------------------------|
| Model | | SV510TF-II | |
| Weight | Operating weight | | 13,550 kg (28,875 lbs.) |
| | Front axle | | 8,440 kg (18,610 lbs.) |
| | Rear axle | | 5,110 kg (11,265 lbs.) |
| Dimensions | Overall length | | 5,750 mm (226 in.) |
| | Overall width | | 2,300 mm (91 in.) |
| | Overall height | | 2,900 mm (114 in.) |
| | Wheelbase | | 2,970 mm (117 in.) |
| | Minimum height above ground | | 465 mm (18.5 in.) |
| | Compaction width | | 2,130 mm (84 in.) |
| | Curve clearance | | 485 mm (19.0 in.) |
| Drive speed | 1 st | | 0 ~ 6 km/h (0 ~ 3.7 mph) |
| | 2 nd | | 0 ~ 10 km/h (0 ~ 6.2 mph) |
| Vibration performance | Vibration frequency | Low amplitude | 36.7 Hz |
| | | High amplitude | 27.5 Hz |
| | Centrifugal force | Low amplitude | 186 kN (41,890 lbf.) |
| | | High amplitude | 245 kN (55,120 lbf.) |
| | Amplitude | Low amplitude | 0.9 mm (0.04 in.) |
| | | High amplitude | 2.0 mm (0.08 in.) |
| Minimum turning radius | | | 5.6 m (221 in.) |
| Gradability*1 | | | 62 % (32 °) |

SPECIFICATION DATA

| | | | |
|----------------------|--|------------------------------|--|
| Engine | Name | | Isuzu BB-6BG1T diesel engine |
| | Model | | Water-cooled, 4-cycle, in-line, direct-injection, with turbocharger |
| | Number of cylinders - Bore x Stroke | | 6-105 mm × 125 mm (6-4.134 in. × 4.921 in.) |
| | Displacement | | 6,494 liters (396 cu.in.) |
| | Performance | Rated rotating speed | 2,000 min ⁻¹ (2,000 rpm) |
| | | Rated output | 103 kW (138 HP) |
| | | Maximum torque | 515 N·m (380 lbf·ft) at 1600 min ⁻¹ |
| | | Fuel consumption rate | 252 g/kW·h |
| | Fuel system | Fuel | Light oil JIS No. 2 or 3 equivalent |
| | | Speed governor | Mechanical all-speed type |
| | Lubrication system | Lubrication method | Forced circulation |
| | | Filtration method | Combination of full-flow/bypass |
| | Air purification system | | Dry type |
| | Cooling system | Cooling fan | Suction type |
| | | Radiator | Pressure type |
| Charging generator | | 24 V 50 A | |
| Starting motor | | 24 V 4.5 kW | |
| Battery | | 12 V 100 Ah x 2 units (24 V) | |
| Transmission device | Gearshift | Model | Hydrostatic transmission |
| | | Number of speeds | 2nd gear based on variable-capacity motor |
| | Reversing gear | | By conversion in direction of variable-capacity hydraulic pump's oil discharge |
| | Differential | | No-spin differential |
| Final reduction gear | | Planetary gear type | |
| Vibrator | Model | | Hydrostatic type |
| | Vibrating machine | Vibration method | Single-shaft eccentric/variable type (2nd gear variable by normal/reverse rotation of eccentric shaft) |
| | Installation location | | Front-wheel body interior |
| Braking device | Driving brake | | Hydrostatic brake, mechanical wet multiple-disc type |
| | Parking brake | | Mechanical wet multiple-disc type |
| Steering system | Steering control type | | Articulated fully hydraulic type |
| | Steering control angle | | ±37° |
| | Oscillation angle | | ±6.8° |
| Wheels | Front wheels (diameter x width) (vibration and driving wheels) | | 1,650 mm × 2,130 mm (65 in. × 84 in.) |
| | Rear wheels (size) (driving wheels) | | 23.1-26-8 PR (OR) |
| Other | Ropes | | Iron |
| | Electrical components and instruments | | 1 set |

•1: The gradability is the calculated value. It may vary based on the ground surface conditions.

SPECIFICATION DATA

1-5. SV510TFB-II

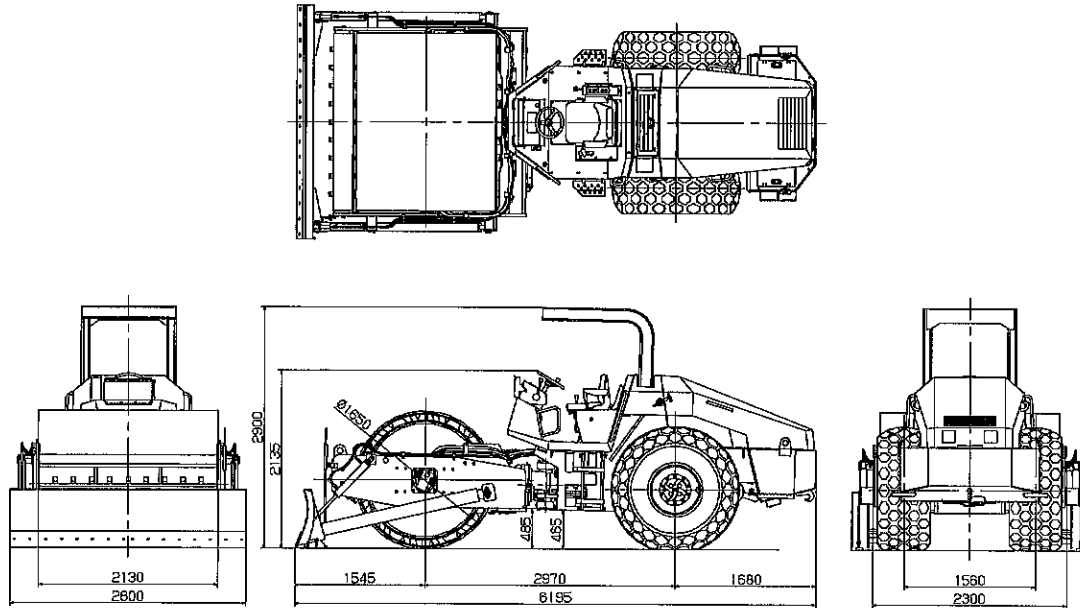

| | | | |
|------------------------|-----------------------------|----------------|---------------------------|
| Model | | SV510TFB-II | |
| Weight | Operating weight | | 14,030 kg (30,930 lbs.) |
| | Front axle | | 9,020 kg (19,885 lbs.) |
| | Rear axle | | 5,010 kg (11,045 lbs.) |
| Dimensions | Overall length | | 6,195 mm (224 in.) |
| | Overall width | | 2,800 mm (110 in.) |
| | Overall height | | 2,900 mm (114 in.) |
| | Wheelbase | | 2,970 mm (117 in.) |
| | Minimum height above ground | | 465 mm (18.5 in.) |
| | Compaction width | | 2,130 mm (84 in.) |
| | Curve clearance | | 485 mm (19.0 in.) |
| Drive speed | 1 st | | 0 ~ 6 km/h (0 ~ 3.7 mph) |
| | 2 nd | | 0 ~ 10 km/h (0 ~ 6.2 mph) |
| Vibration performance | Vibration frequency | Low amplitude | 36.7 Hz |
| | | High amplitude | 27.5 Hz |
| | Centrifugal force | Low amplitude | 186 kN (41,890 lbf.) |
| | | High amplitude | 245 kN (55,120 lbf.) |
| | Amplitude | Low amplitude | 0.8 mm (0.03 in.) |
| | | High amplitude | 1.7 mm (0.07 in.) |
| Minimum turning radius | | | 5.6 m (221 in.) |
| Gradability*1 | | | 62 % (32 °) |

SPECIFICATION DATA

| | | | |
|---------------------|--|------------------------------|--|
| Engine | Name | | Isuzu BB-6BG1T diesel engine |
| | Model | | Water-cooled, 4-cycle, in-line, direct-injection, with turbocharger |
| | Number of cylinders - Bore x Stroke | | 6-105 mm × 125 mm (6-4.134 in. × 4.921 in.) |
| | Displacement | | 6,494 liters (396 cu.in.) |
| | Performance | Rated rotating speed | 2,000 min ⁻¹ (2,000 rpm) |
| | | Rated output | 103 kW (138 HP) |
| | | Maximum torque | 515 N·m (380 lbf·ft) at 1600 min ⁻¹ |
| | | Fuel consumption rate | 252 g/kW·h |
| | Fuel system | Fuel | Light oil JIS No. 2 or 3 equivalent |
| | | Speed governor | Mechanical all-speed type |
| | Lubrication system | Lubrication method | Forced circulation |
| | | Filtration method | Combination of full-flow/bypass |
| | Air purification system | | Dry type |
| | Cooling system | Cooling fan | Suction type |
| | | Radiator | Pressure type |
| | Charging generator | | 24 V 50 A |
| Starting motor | | 24 V 4.5 kW | |
| Battery | | 12 V 100 Ah x 2 units (24 V) | |
| Transmission device | Gearshift | Model | Hydrostatic transmission |
| | | Number of speeds | 2nd gear based on variable-capacity motor |
| | Reversing gear | | By conversion in direction of variable-capacity hydraulic pump's oil discharge |
| | Differential | | No-spin differential |
| | Final reduction gear | | Planetary gear type |
| Vibrator | Model | | Hydrostatic type |
| | Vibrating machine | Vibration method | Single-shaft eccentric/variable type (2nd gear variable by normal/reverse rotation of eccentric shaft) |
| | Installation location | | Front-wheel body interior |
| Braking device | Driving brake | | Hydrostatic brake, mechanical wet multiple-disc type |
| | Parking brake | | Mechanical wet multiple-disc type |
| Steering system | Steering control type | | Articulated fully hydraulic type |
| | Steering control angle | | ±37° |
| | Oscillation angle | | ±6.8° |
| Wheels | Front wheels (diameter x width) (vibration and driving wheels) | | 1,650 mm × 2,130 mm (65 in. × 84 in.) |
| | Rear wheels (size) (driving wheels) | | 23.1-26-8 PR (OR) |
| Other | Ropes | | Iron |
| | Electrical components and instruments | | 1 set |

•1: The gradability is the calculated value. It may vary based on the ground surface conditions.

TABLE OF STANDARD VALUES

2. TABLE OF STANDARD VALUES

2-1. Engine

| Classification | Item | Standard value | Remarks |
|----------------|--------------------------------------|--|--|
| Engine | Engine model | Isuzu BB-6BG1T | |
| | Rated output | 103/2000 kW/rpm (138/2000 HP/rpm) | No fan net |
| | Max. rpm under no load | 2,230 $\frac{0}{-50}$ rpm | When vehicle is shipped |
| | Min. rpm under no load | 900 \pm 25 rpm | When vehicle is shipped |
| | Cylinder head tightening torque | 68 ~ 88 N·m (50 ~ 65 lbf·ft) | |
| | Intake manifold tightening torque | 21 ~ 30 N·m (15 ~ 22 lbf·ft) | |
| | Exhaust manifold tightening torque | 25 ~ 31 N·m (18 ~ 23 lbf·ft) | |
| | Fan belt tension (deflection volume) | 10 ~ 15 mm (0.39 ~ 0.59 in.) | When pressure of 10 kg is applied at belt center |
| | Valve clearance (intake) | 0.4 mm (0.016 in.) | |
| | Valve clearance (exhaust) | 0.4 mm (0.016 in.) | |
| | Compression pressure | 3.0 MPa (435 psi) | |
| | Injection pressure | 18.1 MPa (2625 psi) | |
| | Fuel consumption rate | 252 \pm 13.6 g/kW·h (0.414 lb/HP·h) | When engine is at rated output |
| | Engine dry mass | 493 kg (1087 lb.) | |

2-2. Drive device

| Classification | Item | | Standard value | Remarks |
|----------------|-------------------------|----------------|----------------------|---------------------------|
| Drive device | Vehicle speed | Forward travel | 1 st | 0 ~ 6 km/h (0 ~ 3.7 mph) |
| | | | 2 nd | 0 ~ 10 km/h (0 ~ 6.2 mph) |
| | | Reverse travel | 1 st | 0 ~ 6 km/h (0 ~ 3.7 mph) |
| | | | 2 nd | 0 ~ 10 km/h (0 ~ 6.2 mph) |
| | Rear wheel/hub nut | | 785 N·m (579 lbf·ft) | |
| | Tire inflation pressure | | 137 kPa (20 psi) | |

TABLE OF STANDARD VALUES

2-3. Hydraulic devices

| Classification | Item | Standard value | Remarks | |
|---|--|--|---|---|
| Hydraulic device | Propulsion circuit | Pressure limit pressure setting | 41.8±1.0 MPa (6061±145 psi) | When 1800 min ⁻¹ |
| | | Charge relief pressure setting | 1.9±0.2 MPa (276±30 psi) | |
| | | Drive motor drainage (front wheels) | Less than 10.4 L/min (less than 2.7 gal./min) | Allowable maximum value (at maximum rotation) |
| | | Drive motor drainage (rear wheels) | Less than 6.4 L/min (less than 1.7 gal./min) | Allowable maximum value (at maximum rotation) |
| | Rear axle brake release pressure | 1.5 ~ 3.0 MPa (218 ~ 435 psi) | | |
| | Vibration circuit | Relief pressure setting (front wheels) | 25.0±1.0 MPa (3625±145 psi) | |
| | | Charge relief pressure setting | 2.34±0.2 MPa (339±30 psi) | |
| | | Vibrator motor drainage | Less than 9.8 L/min (less than 2.6 gal./min) | Allowable maximum value (at maximum rotation) |
| | Steering circuit (Orbitrol relief pressure setting + charge relief pressure setting) | 16.9±1.0 MPa (2451±145 psi) | | |
| | Maximum stroke of drive pump control valve lever (forward side) | 24 ~ 29 mm (0.94 ~ 1.14 in.) | | |
| Maximum stroke of drive pump control valve lever (reverse side) | 24 ~ 29 mm (0.94 ~ 1.14 in.) | | | |

2-4. Steering devices

| Classification | Item | Standard value | Remarks |
|-------------------------|------------------------|----------------------------------|---------------------------------|
| Steering control device | Play in steering wheel | 5 ~ 10 mm (0.2 ~ 0.4 in.) | Steering wheel circumference |
| | | 0.5 mm or less (0.2 in. or less) | Steering column shaft direction |

TABLE OF STANDARD VALUES

2-5. Brakes

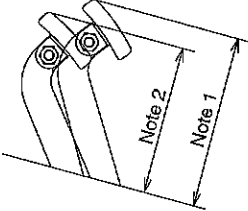
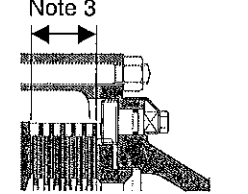
| Classification | Item | Standard value | Remarks |
|----------------|--|--|---|
| Brake | Clearance between pedal brake and floorboard (when attached) | 169 mm (6.7 in.) Note 1: See dimensions. |  |
| | Clearance between pedal brake and floorboard (when pressed down) | 145 mm (5.7 in.) Note 2: See dimensions. | |
| | Brake replacement standards Disc ass'y (6-unit) dimensions (wear limit) | 26.1 ~ 26.7 mm (1.02 ~ 1.05 in.) Note 3: See dimensions. Standard dimensions: 28.5 ~ 29.1 mm (1.12 ~ 1.15 in.) | <p>Note 3</p>  |

2-6. Oil and grease capacity

| Classification | Item | Standard value | Remarks |
|---------------------|---------------------------------|----------------------------|---------|
| Oil/grease capacity | Engine oil | 13 L (3.4 gal.) | |
| | Cooling water | 22 L (5.8 gal.) | |
| | Wheel motor reduction gear case | 3.9 L (1.0 gal.) | |
| | Gear oil (front) | | |
| | Gearbox (rear) | 2.0 L (0.5 gal.) | |
| | Differential case (rear) | 9.5 L (2.5 gal.) | |
| | Final drive case (rear) | 1.75 L X 2 (0.46 gal. X 2) | |
| | Vibrator case gear oil (front) | 37 L (9.8 gal.) | |
| | Reduction gear case gear oil | 2.0 L (0.5 gal.) | |
| | Hydraulic fluid tank oil | 50 L (13.2 gal.) | |
| | Fuel tank | 250 L (66.1 gal.) | |

Note: Precondition for measuring hydraulic device, vehicle speed and vibration frequency: Hydraulic fluid temperature of 50±5°C (122±5°F)

3. FUEL AND LUBRICANTS SPECIFICATION

3-1. Rating

| Lubricant | Service classification | Ambient temp. and applicable viscosity rating | | | Applicable Standards |
|---------------|-------------------------------|---|--|---|----------------------|
| | | -15 ~ 30 °C (5 ~ 86 °F) Cold | 0 ~ 40 °C (32 ~ 104 °F) Moderate | 15 ~ 55 °C (59 ~ 131 °F) Tropical | |
| Engine oil | API grade CD | SAE 10W-30 | SAE 30 | SAE 40 | MIL-L-2104D |
| Gear oil | API grade GL4 | SAE 80W-90 | SAE 90 | SAE 140 | MIL-L-2105 |
| Hydraulic oil | Wear resistant | ISO-VG32 Over VI 140 | ISO-VG46 Over VI 140 | ISO-VG68 Over VI 110 | ISO-3448 |
| Grease | Lithium type extreme pressure | | | | NLGI-2 |
| Fuel | Diesel oil | | | | ASTM D975-2D |

3-2. Recommended lubricants

| Lubricant Oil company | Engine oil API-CC | Gear oil API GL 40 | Hydraulic VG 46 | Grease (NLGI- II) |
|--------------------------|----------------------------|------------------------|------------------------|------------------------------|
| CALTEX | RPM DELO 300 oil | Universal Thuban 90 | Rando Oil HD 46 | Martifack EP-5 |
| BP | BP Vanellus C3-30 | BP Gear Oil EP 90 | BP Energol HLP 46 | BBP Energrease LS-EP 2 |
| ESSO | Esso Lube D3-330 | Esso Gear Oil GP 90 | Nuto H 46 | Beacon EP-2 |
| MOBIL | Mobil Delvac 1330 | Mobil Prgasus | Nuto Oil 25 | Beacon EP 25 |
| SHELL | Shell Rotella CT Oil 30 | Shell Spirax 90 EP | Shell Tellus Oil 48 | Shell Alvania EP Grease 2 |
| CASTROL | Castrol CRD 30 | Castrol Hypoy 90 | Hyspin AWS 46 | Spherrol ELP 2 |

- ▲CAUTION: (1) Fill the fluid reservoirs with the filters installed.
(2) Use recommended fuels and lubricants only.**

TIGHTENING TORQUE CHART

4. TIGHTENING TORQUE CHART

N · m (lb · ft)

| | Nominal Dia. | Pitch | Strength Classification | | | | | | | |
|---------------------|--------------|-------|-------------------------|-------|-------|--------|--------|--------|--------|--------|
| | | | 6.8 | | 8.8 | | 10.9 | | 12.9 | |
| Metric coarse screw | 5 | 0.8 | 4.9 | (3.6) | 5.9 | (4.4) | 7.8 | (5.8) | 7.8 | (5.8) |
| | 6 | 1.0 | 7.8 | (5.8) | 9.8 | (7.2) | 13 | (9.6) | 13 | (9.6) |
| | 8 | 1.25 | 17 | (13) | 23 | (17) | 31 | (23) | 31 | (23) |
| | 10 | 1.5 | 39 | (29) | 49 | (36) | 59 | (44) | 59 | (44) |
| | 12 | 1.75 | 69 | (51) | 78 | (58) | 108 | (80) | 108 | (80) |
| | 14 | 2.0 | 98 | (72) | 127 | (94) | 167 | (123) | 167 | (123) |
| | 16 | 2.0 | 157 | (116) | 196 | (145) | 265 | (195) | 265 | (195) |
| | 18 | 2.5 | 196 | (145) | 245 | (181) | 343 | (253) | 343 | (253) |
| | 20 | 2.5 | 294 | (217) | 392 | (289) | 539 | (398) | 539 | (398) |
| | 22 | 2.5 | 441 | (325) | 539 | (398) | 686 | (506) | 686 | (506) |
| | 24 | 3.0 | 539 | (398) | 637 | (470) | 883 | (651) | 883 | (651) |
| | 27 | 3.0 | 785 | (579) | 981 | (724) | 1324 | (977) | 1324 | (977) |
| 30 | 3.5 | 1079 | (796) | 1324 | (977) | 1765 | (1302) | 1765 | (1302) | |
| Metric fine screw | 10 | 1.25 | 39 | (29) | 49 | (36) | 69 | (51) | 69 | (51) |
| | 12 | 1.25 | 69 | (51) | 88 | (65) | 118 | (87) | 118 | (87) |
| | 14 | 1.5 | 108 | (80) | 137 | (101) | 186 | (137) | 186 | (137) |
| | 16 | 1.5 | 167 | (123) | 206 | (152) | 284 | (209) | 284 | (209) |
| | 18 | 1.5 | 245 | (181) | 294 | (217) | 392 | (289) | 392 | (289) |
| | 20 | 1.5 | 343 | (253) | 441 | (325) | 588 | (434) | 588 | (434) |
| | 22 | 1.5 | 490 | (361) | 588 | (434) | 785 | (579) | 785 | (579) |
| | 24 | 2.0 | 588 | (434) | 735 | (542) | 981 | (724) | 981 | (724) |
| | 27 | 2.0 | 834 | (615) | 1030 | (760) | 1422 | (1049) | 1422 | (1049) |
| | 30 | 2.0 | 1177 | (868) | 1422 | (1049) | 1961 | (1446) | 1961 | (1446) |

ENGINE AND CONTROLS

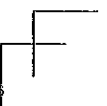
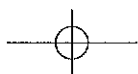
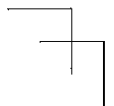
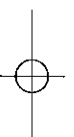
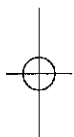
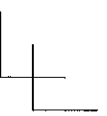
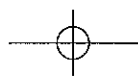
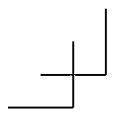

1. ENGINE

1-1. Engine mount

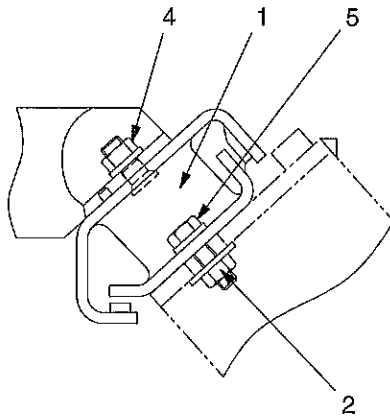
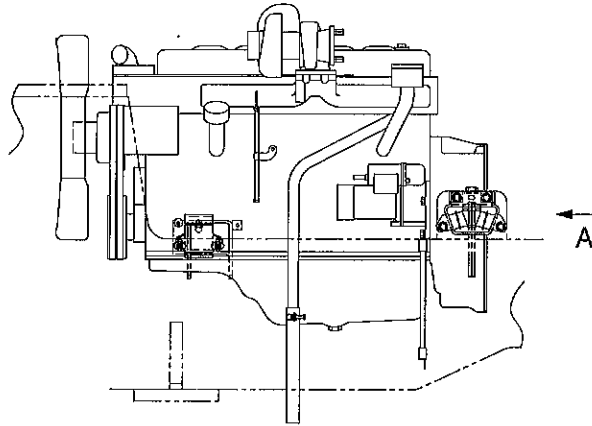
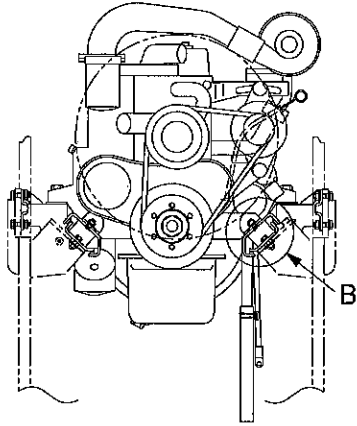

Detail B

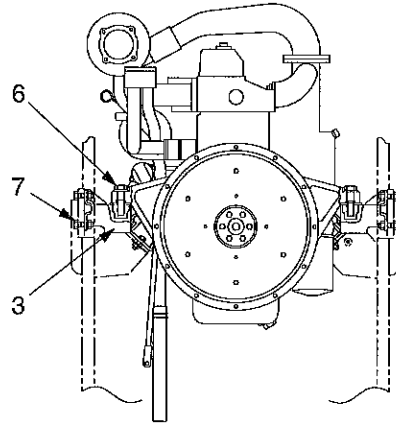

View A

- (1) Damper
- (2) Nut M10
- (3) Damper



- (4) Nut M12 : 80 N·m (59 lbf·ft)
- (5) Bolt M10×35 : 60 N·m (44 lbf·ft)
- (6) Bolt M18×60 : 254 N·m (187 lbf·ft)
- (7) Bolt M12×45 : 110 N·m (81 lbf·ft)

- Engine dry weight : 493 kg (1087 lbs.)
- Engine oil quantity : 13 L (3.4 gal.)

2. CONTROL SYSTEM

2-1. Throttle control

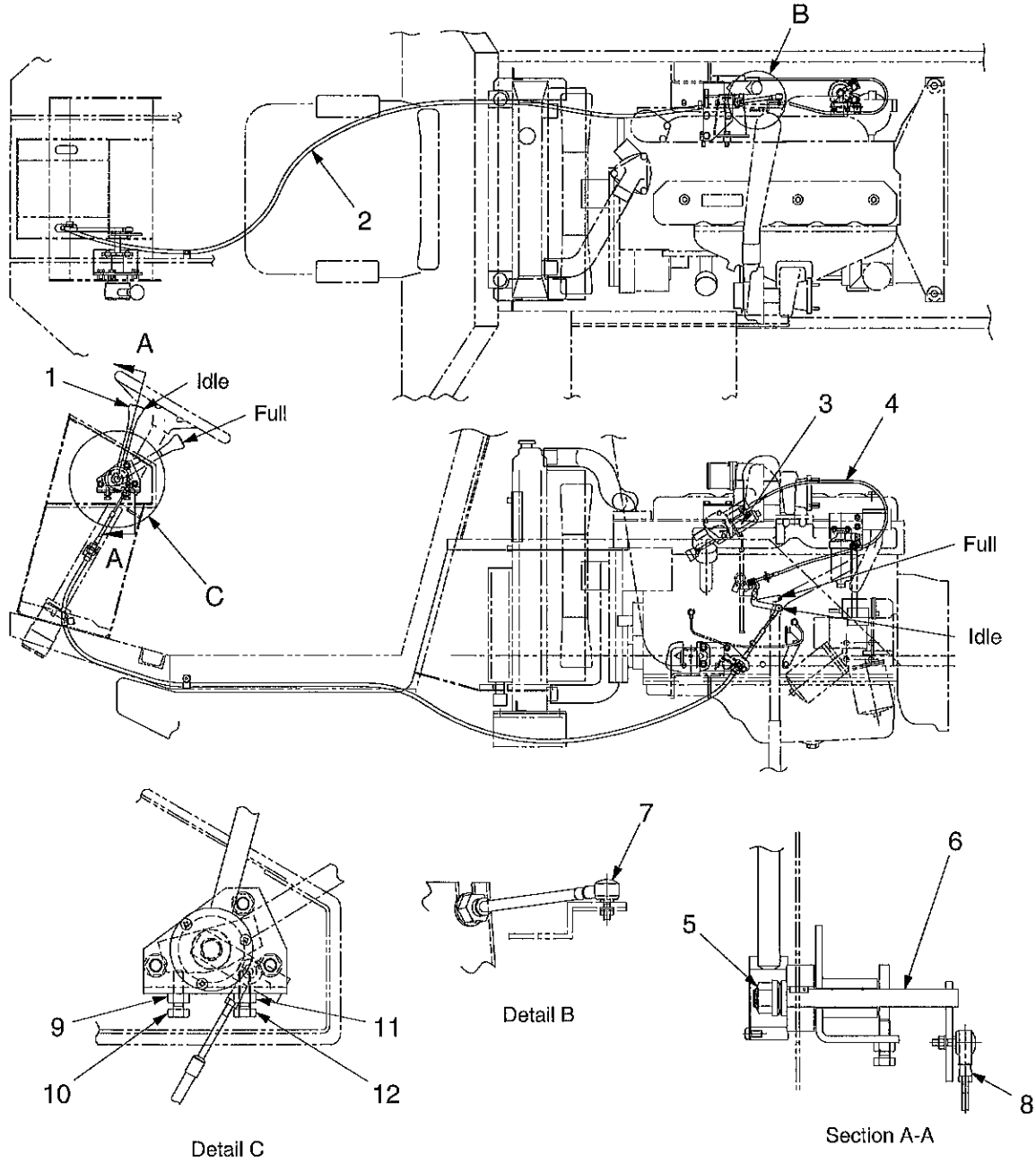

- (1) Throttle lever
- (2) Control cable
- (3) Engine stopper
- (4) Engine stopper cable
- (5) Nut
- (6) Shaft

- (7) Ball joint
- (8) Ball joint
- (9) Locknut
- (10) Idle adjusting bolt
- (11) Locknut
- (12) Full adjusting bolt

3-002

2-2. Forward-reverse control

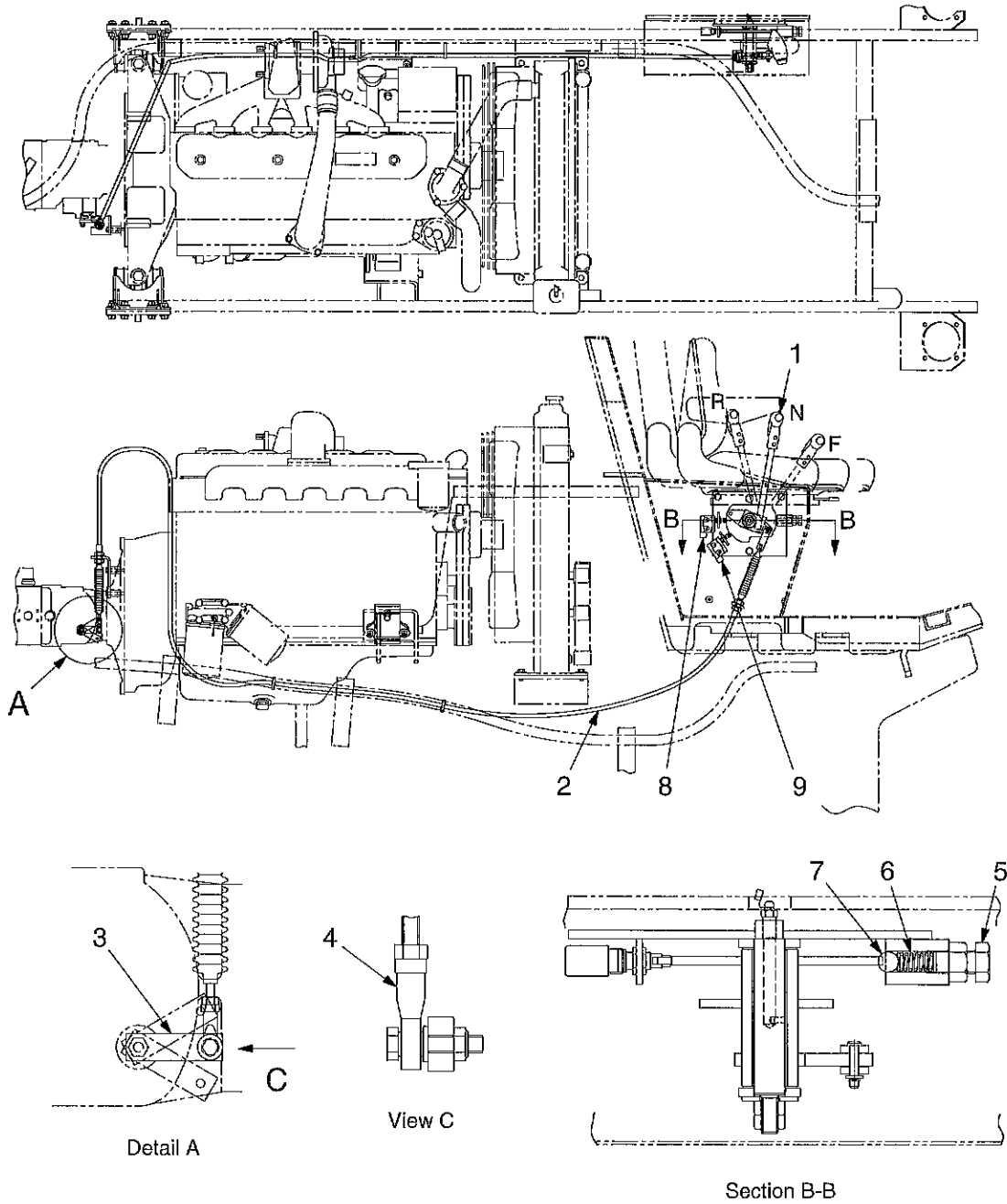

- (1) Forward-reverse lever
- (2) Control cable
- (3) Pump lever
- (4) Rod end
- (5) Bolt

- (6) Spring
- (7) Steel ball
- (8) Interlock switch
- (9) Backup buzzer switch

3. PUMP MOUNT

3-1. Pump mount (SV510D/T/TF-II)

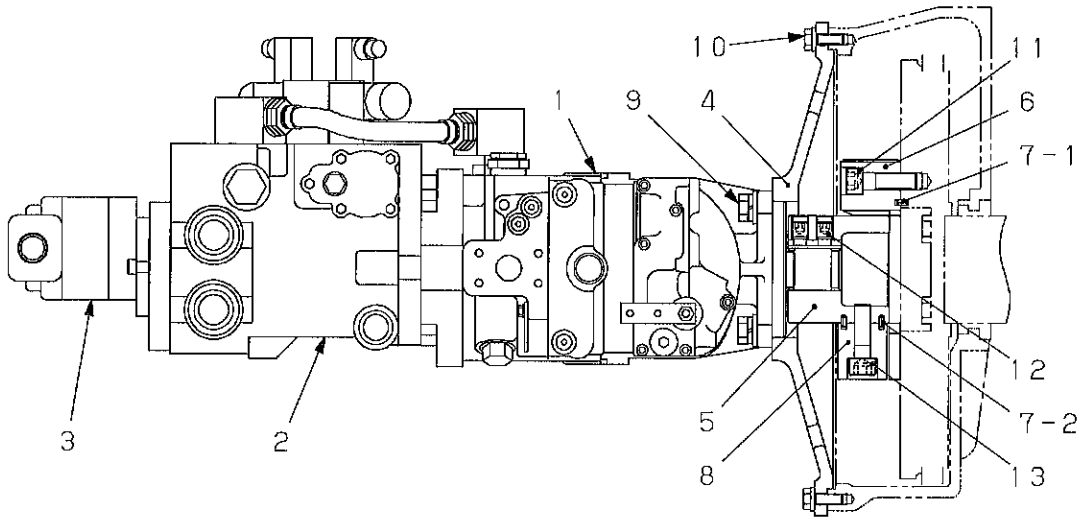

- (1) Propulsion pump
- (2) Vibrator pump
- (3) Steering pump (charge pump)
- (4) Housing
- (5) Hub
- (6) Coupling (aluminum insert NA)
- (7-1) Spring pin
- (7-2) Spring pin
- (8) Coupling (aluminum insert R)

| | | | |
|---|----------|--------------------------------|--|
|  | N · m | | |
| (9) Bolt | : M14×45 | 167 N·m (123 lbf·ft) | |
| (10) Bolt | : M10×30 | 59 N·m (43.5 lbf·ft) | |
| (11) Hexagon socket head bolt | : M16×50 | 210~230 N·m (155~170 lbf·ft) | |
| (12) Set screw | : M16 | 100~120 N·m (73.8~88.5 lbf·ft) | |
| (13) Hexagon socket head bolt | : M16×50 | 210~230 N·m (155~170 lbf·ft) | |

3-2. Pump attachment (SV510D/T/TF-II)

· After removing the pump assembly from the engine for repair or replacement, reattach it in accordance according to the following procedure:

- ① Attach eight positioning spring pins (7-2) to the hub (5).
- ② Apply an ample amount of molybdenum grease to the spline surface of the hub (5) and pump (1).
- ③ Attach the hub (5) to the pump (1), and set to the specified dimensions.

Specified dimensions: $110_{-0.5}^0$ mm (4.33 in)

- ④ Tighten and firmly secure the two set screws (12).

 (12) M16: 110~120 N·m
(73.8~88.5 lbf·ft)

- ⑤ Attach the housing (4) to the pump (1), and firmly secure with the four bolts (9), spring washers and washers.

 (9) M14×45: 167 N·m (123 lbf·ft)

- ⑥ Using the spring pin (7-2), position and attach the coupling's four aluminum inserts R (8) and element to the hub (5).

- ⑦ Tighten and firmly secure the four bolts (13).

 (13) M16×50: 210~230 N·m
(155~170 lbf·ft)

- ⑧ Attach the four positioning spring pins (7-1) to the engine flywheel.

- ⑨ Using the spring pin (7-1), position and attach the coupling's four aluminum inserts NA (6) to the flywheel.

- ⑩ Tighten and firmly secure the four bolts (11).

 (11) M16×50: 210~230 N·m
(155~170 lbf·ft)

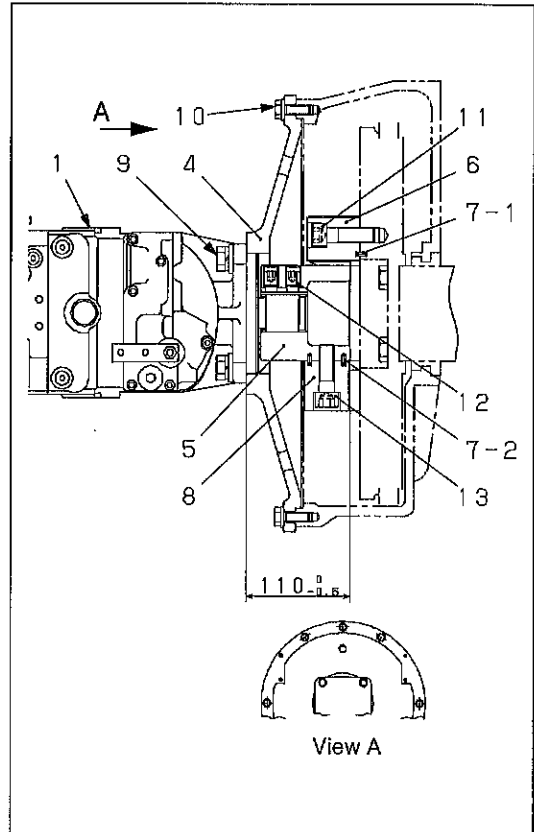

PUMP MOUNT

- ① Ensuring engagement of the aluminum inserts NA (6) and elements attached to the pump side, attach the pump subassembly to the engine.
- ② Tighten and firmly secure the ten bolts (10).

 (10) M10×30: 59 N·m (43.5 lbf·ft)

★ If you replace bolts (11 and 12), which have Loctite applied to them, replace them with new bolts.

3-3. Pump mount (SV510TB/TFB-II)

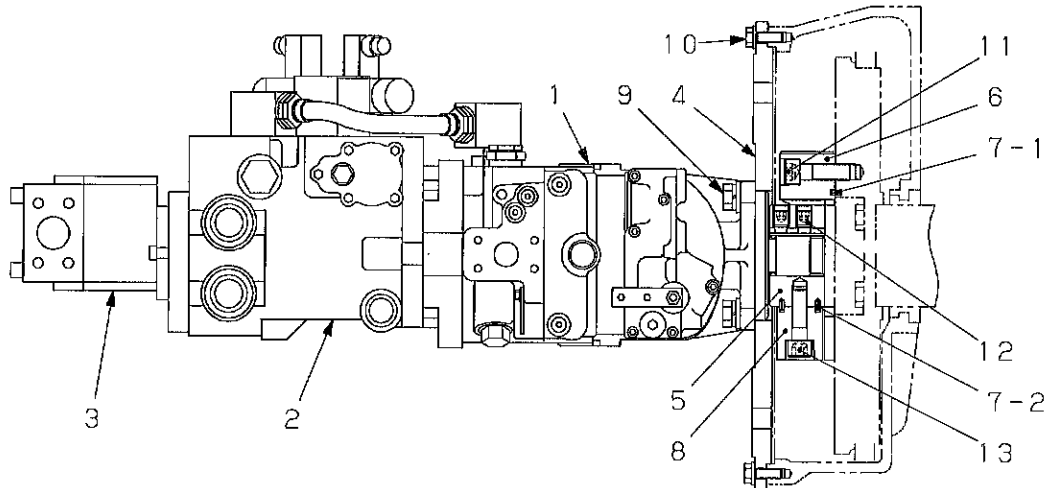

- (1) Propulsion pump
- (2) Vibrator pump
- (3) Steering pump (charge pump)
- (4) Housing
- (5) Hub
- (6) Coupling (aluminum insert NA)
- (7-1) Spring pin
- (7-2) Spring pin
- (8) Coupling (aluminum insert R)



| | | |
|-------------------------------|----------|--------------------------------|
| (9) Bolt | : M14×45 | 167 N·m (123 lbf·ft) |
| (10) Bolt | : M10×30 | 59 N·m (43.5 lbf·ft) |
| (11) Hexagon socket head bolt | : M16×50 | 210~230 N·m (155~170 lbf·ft) |
| (12) Set screw | : M16 | 100~120 N·m (73.8~88.5 lbf·ft) |
| (13) Hexagon socket head bolt | : M16×50 | 210~230 N·m (155~170 lbf·ft) |

3-4. Pump attachment (SV510TB/TBF-II)

• After removing the pump assembly from the engine for repair or replacement, reattach it in accordance according to the following procedure:

- ① Attach eight positioning spring pins (7-2) to the hub (5).
- ② Apply an ample amount of molybdenum grease to the spline surface of the hub (5) and pump (1).
- ③ Attach the hub (5) to the pump (1), and set to the specified dimensions.

Specified dimensions: $70_{-0.5}^0$ mm (4.33 in)

- ④ Tighten and firmly secure the two set screws (12).

 (12) M16: 110 ~ 120 N·m
(73.8 ~ 88.5 lbf·ft)

- ⑤ Attach the housing (4) to the pump (1), and firmly secure with the four bolts (9), spring washers and washers.

 (9) M14×45: 167 N·m (123 lbf·ft)

- ⑥ Using the spring pin (7-2), position and attach the coupling's four aluminum inserts R (8) and element to the hub (5).

- ⑦ Tighten and firmly secure the four bolts (13).

 (13) M16×50: 210 ~ 230 N·m
(155 ~ 170 lbf·ft)

- ⑧ Attach the four positioning spring pins (7-1) to the engine flywheel.

- ⑨ Using the spring pin (7-1), position and attach the coupling's four aluminum inserts NA (6) to the flywheel.

- ⑩ Tighten and firmly secure the four bolts (11).

 (11) M16×50: 210 ~ 230 N·m
(155 ~ 170 lbf·ft)

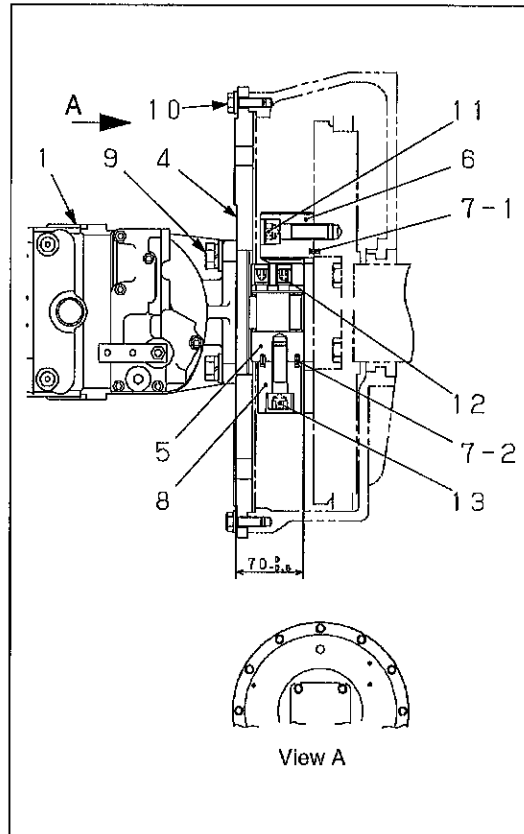

- ⑪ Ensuring engagement of the aluminum inserts NA (6) and elements attached to the pump side, attach the pump subassembly to the engine.
- ⑫ Tighten and firmly secure the ten bolts (10).

 (10) M10×30: 59 N·m (43.5 lbf·ft)

★ **If you replace bolts (11 and 12), which have Loctite applied to them, replace them with new bolts.**

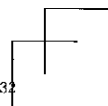
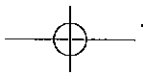
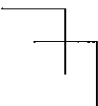
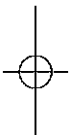
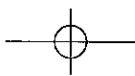
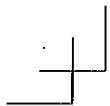

HYDRAULIC SYSTEMS

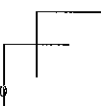
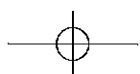
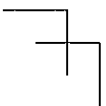
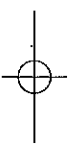
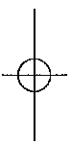
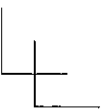
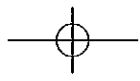
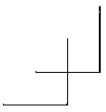

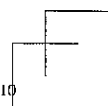
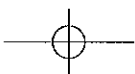
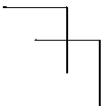
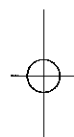
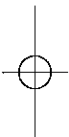
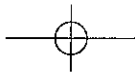

1. SYSTEM CIRCUIT DIAGRAM

1-1. Graphic symbols for hydraulic

Basic Symbols

| DESCRIPTION | SYMBOL |
|---|--------|
| Lines: | |
| Main Working | |
| Pilot Control | |
| Drain or Bleed | |
| Lines, joining | |
| Not Connected | |
| Component Outline | |
| Arrow indicates direction of flow. | |
| Line with fixed restriction (orifice). | |
| Test port, pressure measurement. | |
| Temperature measurement gauge | |
| Pressure measurement gauge | |
| Reservoir (vented) | |
| Filter or Strainer | |
| Heat exchanger, lines indicate flow of coolant. | |
| Quick Disconnect: Connected with mechanically opened checks. Disconnected. | |
| Sloping arrow through a symbol at 45° indicates that a component can be adjusted or varied. | |

Pump, Motors and Cylinders

| DESCRIPTION | SYMBOL |
|---|--------|
| Hydraulic Pumps: | |
| Fixed Displacement | |
| Unidirectional | |
| Bidirectional | |
| Variable Displacement | |
| Unidirectional | |
| Bidirectional | |
| Variable Displacement Pressure Compensated Unidirectional | |
| Hydraulic Motor: | |
| Unidirectional | |
| Bidirectional | |
| Double acting hydraulic cylinder | |
| Differential cylinder | |
| Electric Motor | |

Valves

| DESCRIPTION | SYMBOL |
|--|--------|
| Check Valve | |
| Manual Shut Off (On-Off) | |
| Pressure Relief | |
| Flow control, adjustable | |
| Valve Symbols: The basic valve symbol one or more squares with lines representing flow paths and flow conditions between ports. | |
| Multiple squares indicate a valve with as many distinct positions there are squares providing various flow path options for the fluid. The multiple square moves to represent how flow paths change when the valving element is shifted within the component. | |
| Valves with infinite positioning between certain limits are symbolized with lines parallel to the squares. | |

Methods of Operation

| DESCRIPTION | SYMBOL |
|--|--------|
| Spring | |
| Manual | |
| Pressure Compensated | |
| Reversing Motor | |
| Pilot Pressure: Internal Supply | |
| Remote Supply | |
| Solenoid: Single winding | |
| Two windings operating in opposite directions. | |
| Pilot directional valve is actuated by the solenoid. | |

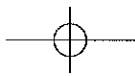
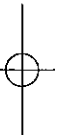
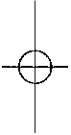
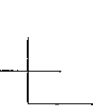
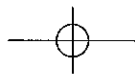
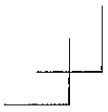

1-2. Hydraulic circuit diagram (SV510D/T/TF-II)

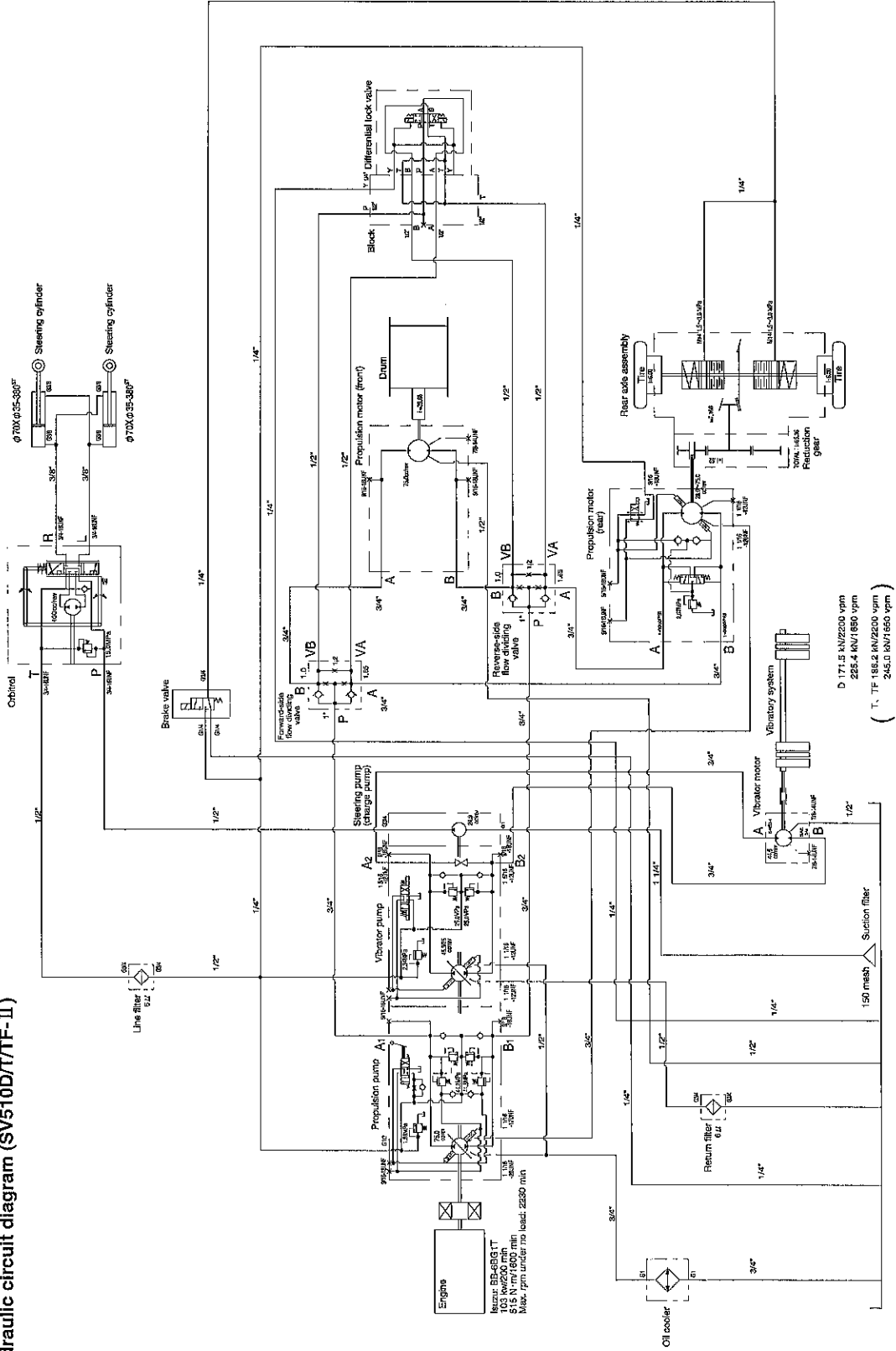



2025/06/10 14:15:47



016f_jitrbvmlk_294404_58.indd 004



1-3. Hydraulic circuit diagram (SV510TB/TFB-II)

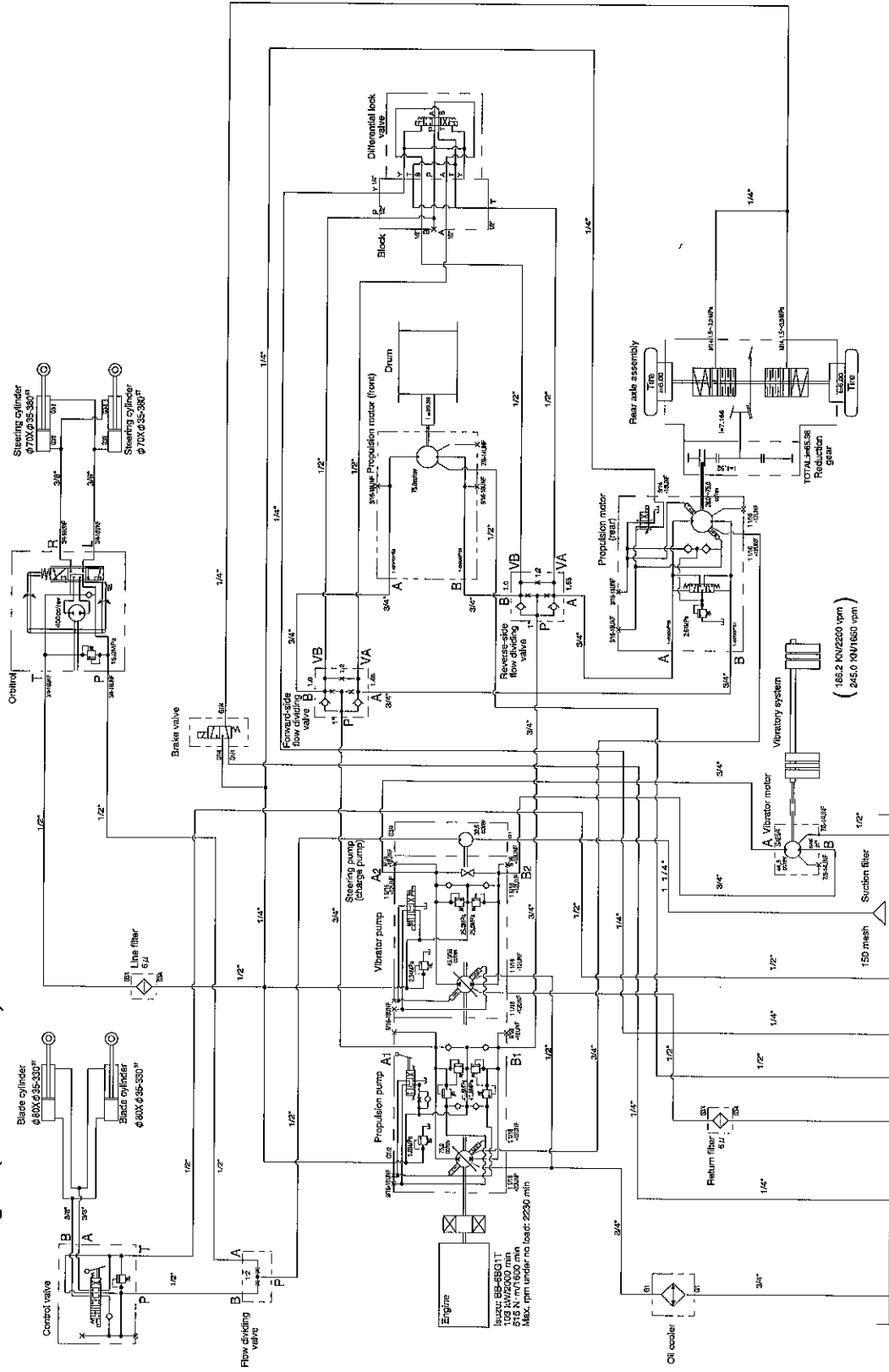



2018/06/10 14:15:48



03E_HYDRAULIC_P4004_A3.mxd Sections



2. PROPULSION HYDRAULIC SYSTEM

2-1. Propulsion hydraulic piping (1) (front)

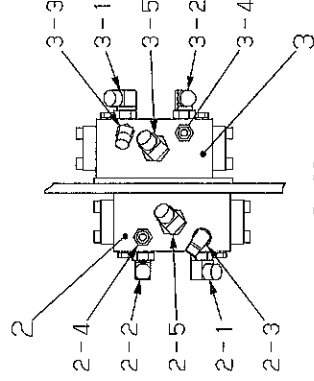
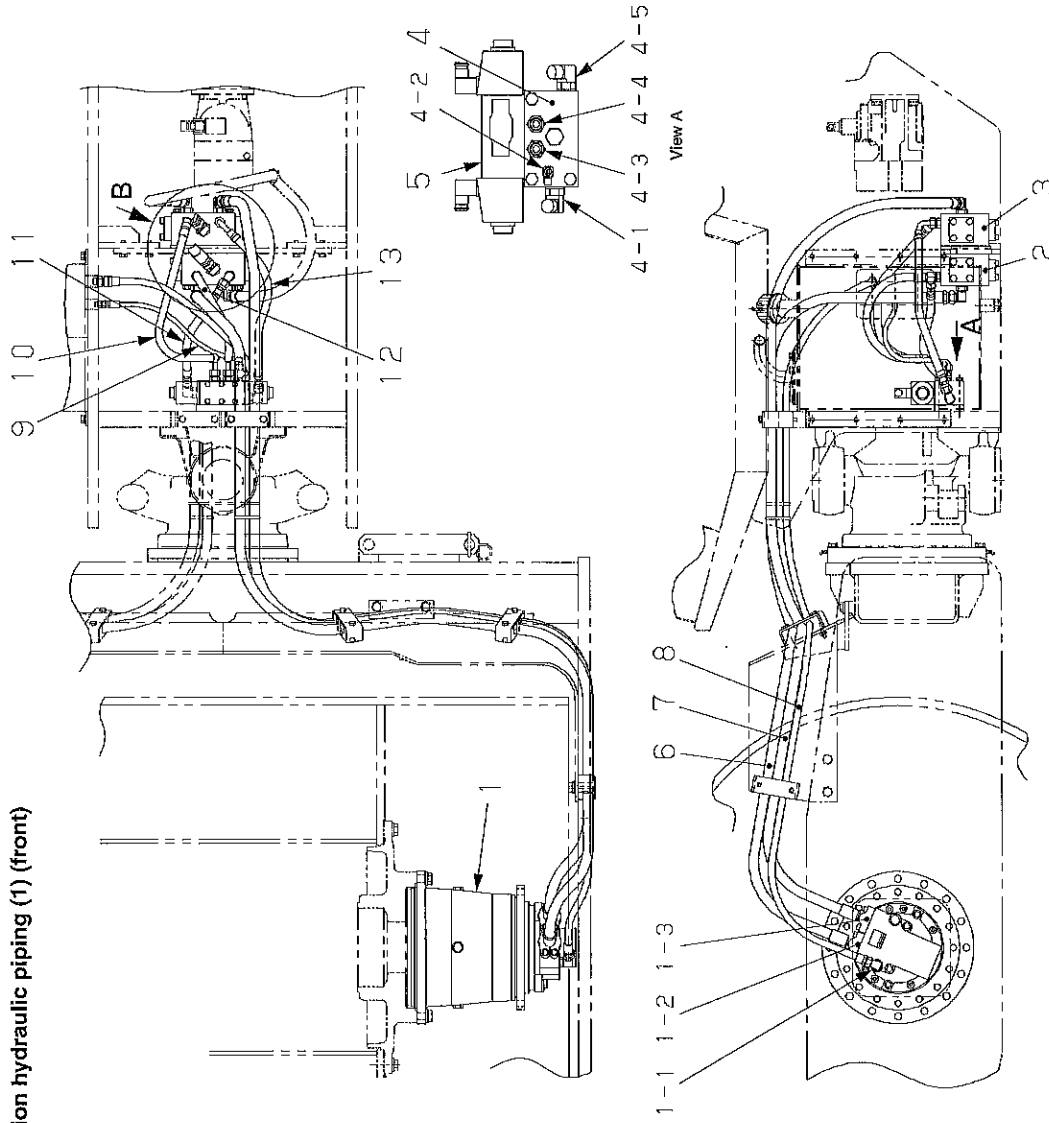

Detail B

- (1) Propulsion motor (front)
 - (1-1) Drain port : 7/8-14UNF-2B
 - (1-2) Port B (forward) : SAE 1"
 - (1-3) Port A (reverse) : SAE 1"
- (2) Flow dividing valve (forward)
 - (2-1) Port A : G3/4"
 - (2-2) Port B : G3/4"
 - (2-3) Port VA : G1/2"
 - (2-4) Port VB : G1/2"
 - (2-5) Port P : G1"
- (3) Flow dividing valve (reverse)
 - (3-1) Port A : G3/4"
 - (3-2) Port B : G3/4"
 - (3-3) Port VA : G1/2"
 - (3-4) Port VB : G1/2"
 - (3-5) Port P : G1"
- (4) Manifold
 - (4-1) Port P : G1/2"
 - (4-2) Port Y : G1/4"
 - (4-3) Port B : G1/2"
 - (4-4) Port A : G1/2"
 - (4-5) Port T : G1/2"
- (5) Differential lock valve
 - (6) Hose : (2-2) → (1-2)
 - (7) Hose : (3-2) → (1-3)
 - (8) Hose : (1-1) → Hydraulic oil tank
 - (9) Hose : (4-2) → Hydraulic oil tank
 - (10) Hose : (3-3) → (4-4)
 - (11) Hose : (2-3) → (4-5)
 - (12) Hose : (2-4) → (4-3)
 - (13) Hose : (3-4) → (4-1)

The figures (such as 1-1 and 2-1) show each port and the arrow (←, →) symbols show the hose connection and the direction of the flow of the oil.



2025/06/10 14:19:55



C:\E:\HYDRALIC_~PA\015_A3.rvt DWF

2-2. Propulsion hydraulic piping (2) (rear)

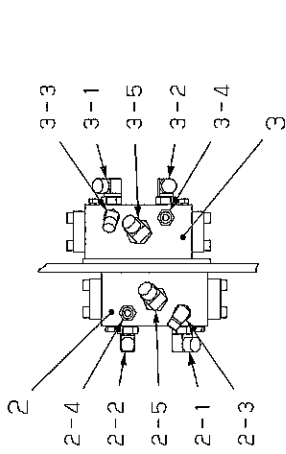
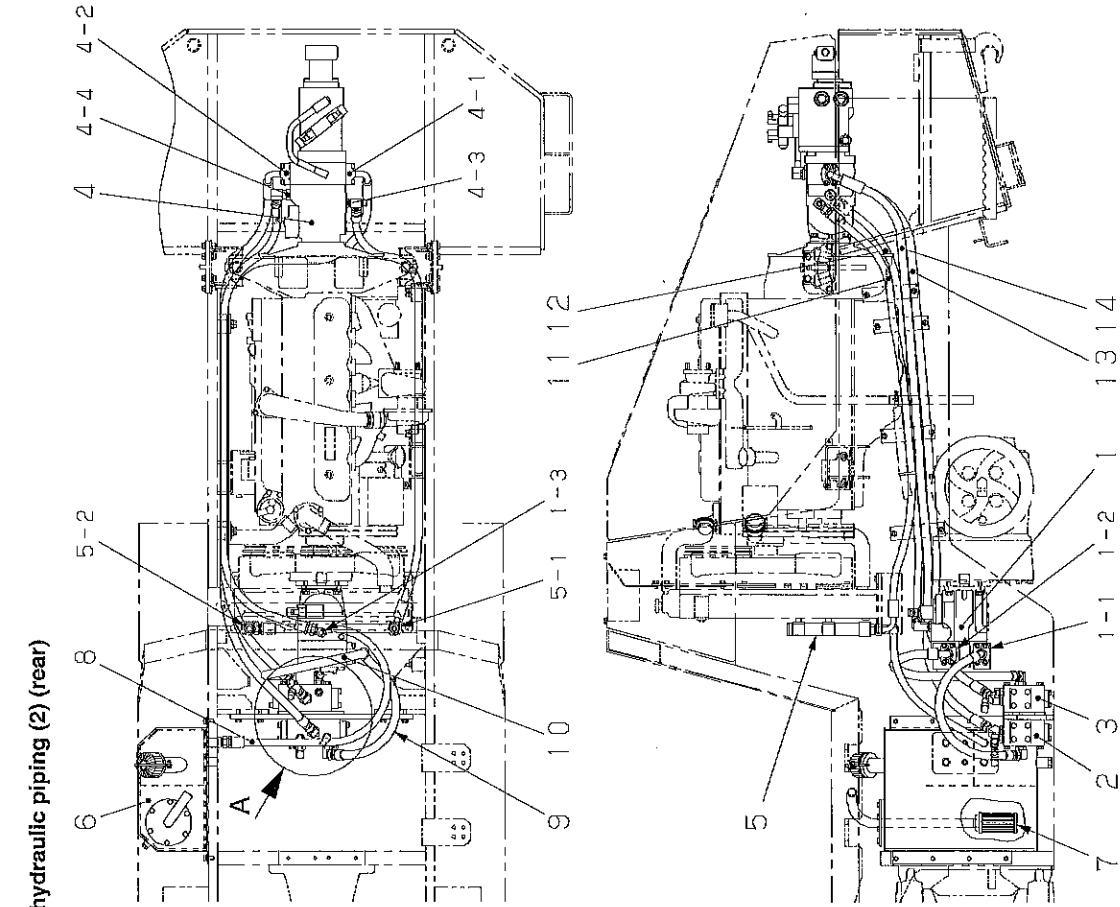

- Detail A
- (1) Propulsion motor (rear)
 - (1-1) Port A : SAE 1"
 - (1-2) Port B : SAE 1"
 - (1-3) Drain port : 1 1/16-12UN-2B
 - (2) Flow dividing valve (forward)
 - (2-1) Port A : G3/4"
 - (2-2) Port B : G3/4"
 - (2-3) Port VA : G1/2"
 - (2-4) Port VB : G1/2"
 - (2-5) Port P : G1"
 - (3) Flow dividing valve (reverse)
 - (3-1) Port A : G3/4"
 - (3-2) Port B : G3/4"
 - (3-3) Port VA : G1/2"
 - (3-4) Port VB : G1/2"
 - (3-5) Port P : G1"
 - (4) Propulsion pump
 - (4-1) Port A1 : SAE 1"
 - (4-2) Port B1 : SAE 1"
 - (4-3) Drain port : 1 1/16-12UN-2B
 - (4-4) Drain port : 1 1/16-12UN-2B
 - (5) Oil cooler
 - (5-1) IN : G1"
 - (5-2) OUT : G1"
 - (6) Hydraulic oil tank
 - (7) Suction filter
 - (8) Hose : (5-2) → Hydraulic oil tank
 - (9) Hose : (2-1) → (1-1)
 - (10) Hose : (3-1) → (1-2)
 - (11) Hose : (4-3) → (5-1)
 - (12) Hose : (1-3) → (4-4)
 - (13) Hose : (4-2) → (2-5)
 - (14) Hose : (4-1) → (3-5)

The figures (such as 1-1 and 2-1) show each port and the arrow (←, →) symbols show the hose connection and the direction of the flow of the oil.



2008/05/10 14:19:55



PACK_HYDRAULIC_P-4-006_A3.indd Sep 10 07



2-3. Hydraulic equipment specifications

2-3-1. Propulsion pump (propulsion, vibrator, steering/charge) (SV510D/TTF-II)

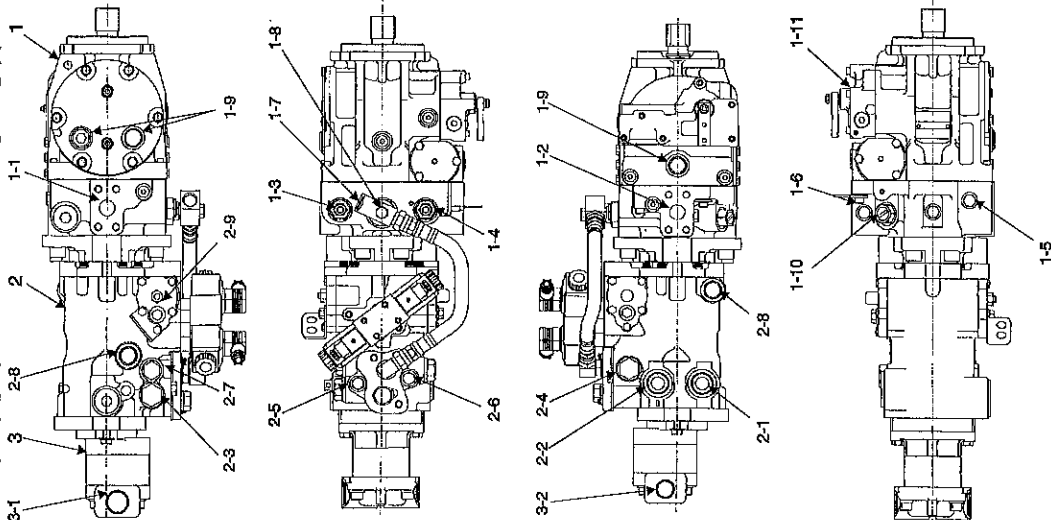

Model: PV07546-611

(1) Propulsion pump

- (1-1) Port A1 (reverse side) : SAE 1"
- (1-2) Port B1 (forward side) : SAE 1"
- (1-3) Multifunction valve (port A) : 9/16-18UN-2B
- (1-4) Multifunction valve (port B) : 9/16-18UN-2B
- (1-5) High-pressure gauge port (port A) : G1/2"
- (1-6) High-pressure gauge port (port B) : 9/16-18UNF-2B
- (1-7) Charge supply port : 1 1/16-12UN-2B
- (1-8) Charge pressure gauge port
- (1-9) Drain port
- (1-10) Charge relief valve
- (1-11) Servo valve (for forward-reverse)

Specifications

- Displacement : 75 cm³/rev (4.6 cu.in./rev)
- Pressure limit pressure setting : 41.8 MPa (6061 psi)
- Charge relief valve pressure setting : 1.89 MPa (274 psi)

(2) Vibrator pump

- (2-1) Port A2 (low-amplitude side) : 1 5/16-12UN-2B
- (2-2) Port B2 (high-amplitude side) : 1 5/16-12UN-2B
- (2-3) High-pressure relief valve (port A2 side)
- (2-4) High-pressure relief valve (port B2 side)
- (2-5) High-pressure gauge port (port A2 side)
- (2-6) High-pressure gauge port (port B2 side)
- (2-7) Charge relief valve
- (2-8) Drain port
- (2-9) Servo pressure gauge port
- (2-10) Amplitude solenoid valve

Specifications

- Displacement : 45.9 cm³/rev (2.8 cu.in./rev) (when low amplitude)
- : 35.0 cm³/rev (2.1 cu.in./rev) (when high amplitude)
- High-pressure relief pressure setting : 25.0 MPa (3625 psi)
- Charge relief valve pressure setting : 2.34 MPa (339 psi)

(3) Steering pump/charge pump

- (3-1) Suction port : G1"
- (3-2) Discharge port : G3/4"

Specifications

- Displacement : 24.9 cm³/rev (1.5 cu.in./rev)
- Propulsion pump assembly weight : 94.5 kg (208 lbs.)



2008/05/10 14:15:55



01#_HYDRAULIC_P4-008_A3.WPS 5662008



Model: PV07546-612

2-3-2. Propulsion pump (propulsion, vibrator, steering/charge) (SV510TB/TFB-II)

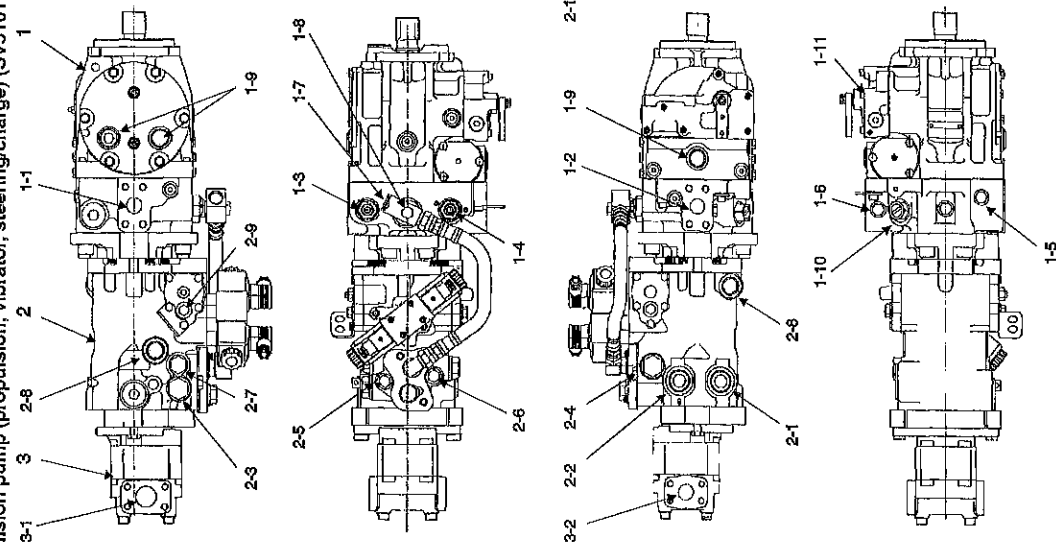

- (1) Propulsion pump
- (1-1) Port A1 (reverse side)
 - (1-2) Port B1 (forward side)
 - (1-3) Multifunction valve (port A)
 - (1-4) Multifunction valve (port B)
 - (1-5) High-pressure gauge port (port A)
 - (1-6) High-pressure gauge port (port B)
 - (1-7) Charge supply port
 - (1-8) Charge pressure gauge port
 - (1-9) Drain port
 - (1-10) Charge relief valve
 - (1-11) Servo valve (for forward-reverse)

- Specifications
- Displacement : 75 cm³/rev (4.6 cu.in./rev)
 - Pressure limit pressure setting : 41.8 MPa (6061 psi)
 - Charge relief valve pressure setting : 1.89 MPa (274 psi)

- (2) Vibrator pump
- (2-1) Port A2 (low-amplitude side)
 - (2-2) Port B2 (high-amplitude side)
 - (2-3) High-pressure relief valve (port A2 side)
 - (2-4) High-pressure relief valve (port B2 side)
 - (2-5) High-pressure gauge port (port A2 side)
 - (2-6) High-pressure gauge port (port B2 side)
 - (2-7) Charge relief valve
 - (2-8) Drain port
 - (2-9) Servo pressure gauge port
 - (2-10) Amplitude solenoid valve

- Specifications
- Displacement : 45.9 cm³/rev (2.8 cu.in./rev) (when low amplitude)
 - : 35.0 cm³/rev (2.1 cu.in./rev) (when high amplitude)
 - High-pressure relief pressure setting : 25.0 MPa (3625 psi)
 - Charge relief valve pressure setting : 2.34 MPa (339 psi)

- (3) Steering pump/charge pump
- (3-1) Suction port
 - (3-2) Discharge port
- Specifications
- Displacement : 32.5 cm³/rev (2.0 cu.in./rev)
 - Propulsion pump assembly weight : 94.5 kg (208 lbs.)

: SAE 1"

: SAE 1"

: 9/16-18UN-2B

: 9/16-18UN-2B

: G1/2"

: 9/16-18UN-2B

: 1 1/16-12UN-2B

: 75 cm³/rev (4.6 cu.in./rev)

: 41.8 MPa (6061 psi)

: 1.89 MPa (274 psi)

: 1 5/16-12UN-2B

: 1 5/16-12UN-2B

: 9/16-18UNF-2B

: 9/16-18UNF-2B

: 1 1/16-12UN-2B

: 9/16-18UNF-2B

: 45.9 cm³/rev (2.8 cu.in./rev) (when low amplitude)

: 35.0 cm³/rev (2.1 cu.in./rev) (when high amplitude)

: 25.0 MPa (3625 psi)

: 2.34 MPa (339 psi)

: G1"

: G3/4"

: 32.5 cm³/rev (2.0 cu.in./rev)

: 94.5 kg (208 lbs.)



2008/05/14 14:19:25



04es_PTP04A11K_~P4-004_03.mxd 8ea 009



2-3-3. Propulsion hydraulic motor (front)

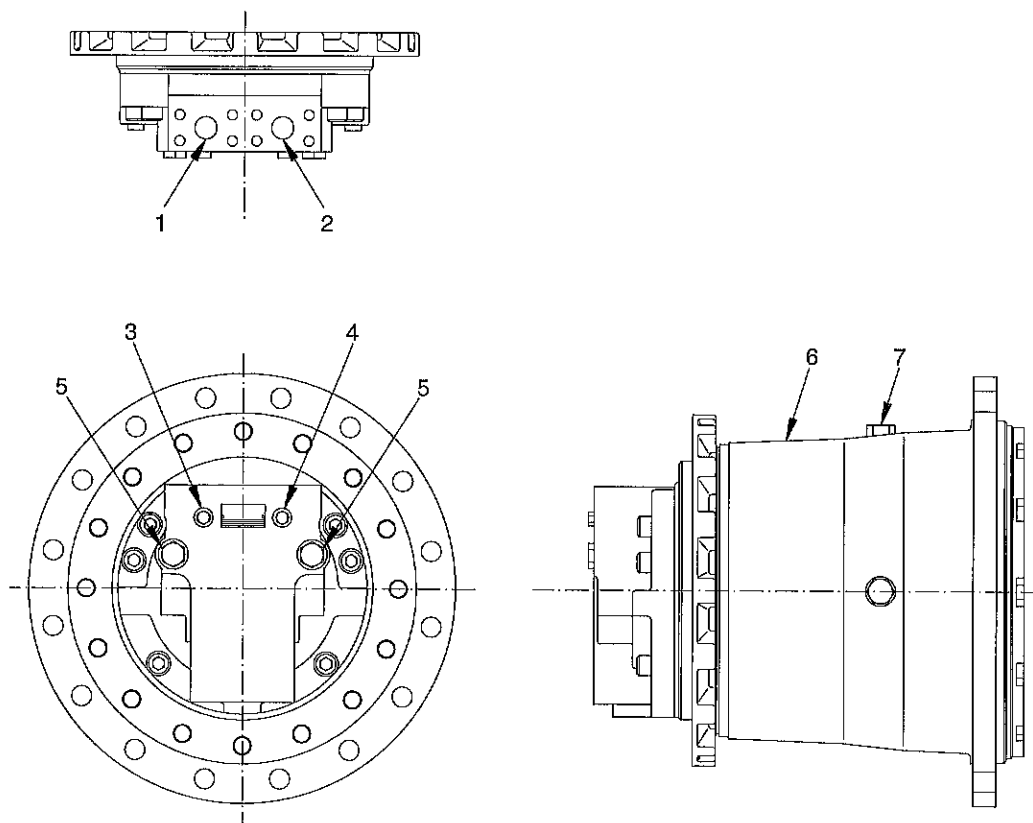

- (1) Port B (forward travel) : SAE 1"
- (2) Port A (reverse travel) : SAE 1"
- (3) High-pressure gauge port (port B side): 9/16-18UNF
- (4) High-pressure gauge port (port A side): 9/16-18UNF

- (5) Drain port : 7/8-14UNF
- (6) Reduction gear
- (7) Filler cap : 7/8-14UNF

Motor specifications

- Model : MF75AD-40EH
- Displacement : 75 cm³/rev (4.6 cu.in./rev)
- Maximum working pressure : 41.8 MPa (6061 psi)

Reduction gear specifications

- Reduction ratio : 1/39.884
- Propulsion hydraulic motor weight : 213 kg (470 lbs.)

2-3-4. Internal structure of propulsion hydraulic motor (front)

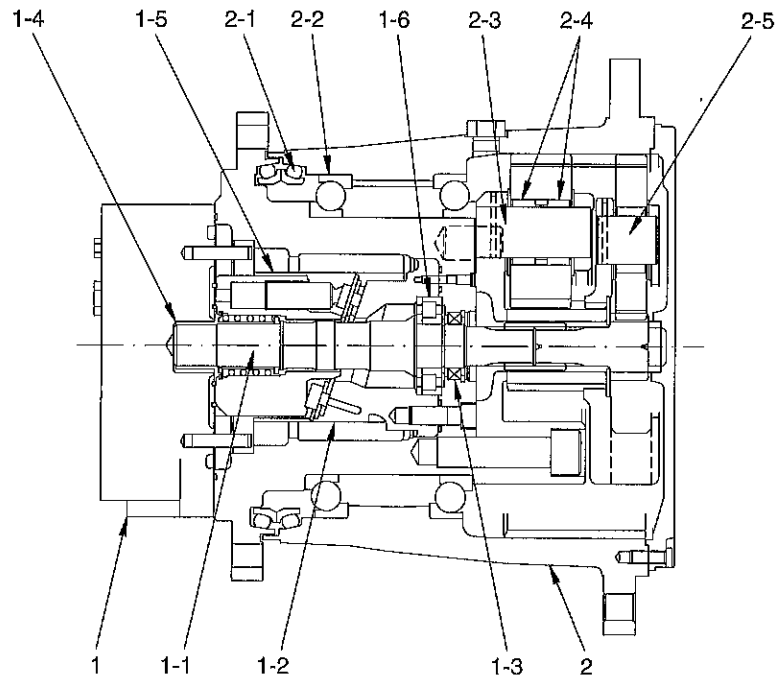

(1) Motor

- (1-1) Shaft
- (1-2) Swashplate assembly
- (1-3) Oil seal
- (1-4) Journal bearing
- (1-5) Cylinder block kit
- (1-6) Roller bearing

(2) Reduction gear

- (2-1) Floating seal kit
- (2-2) Angular bearing
- (2-3) Shaft A
- (2-4) Needle roller
- (2-5) Shaft B

2-3-5. Propulsion hydraulic motor (rear)

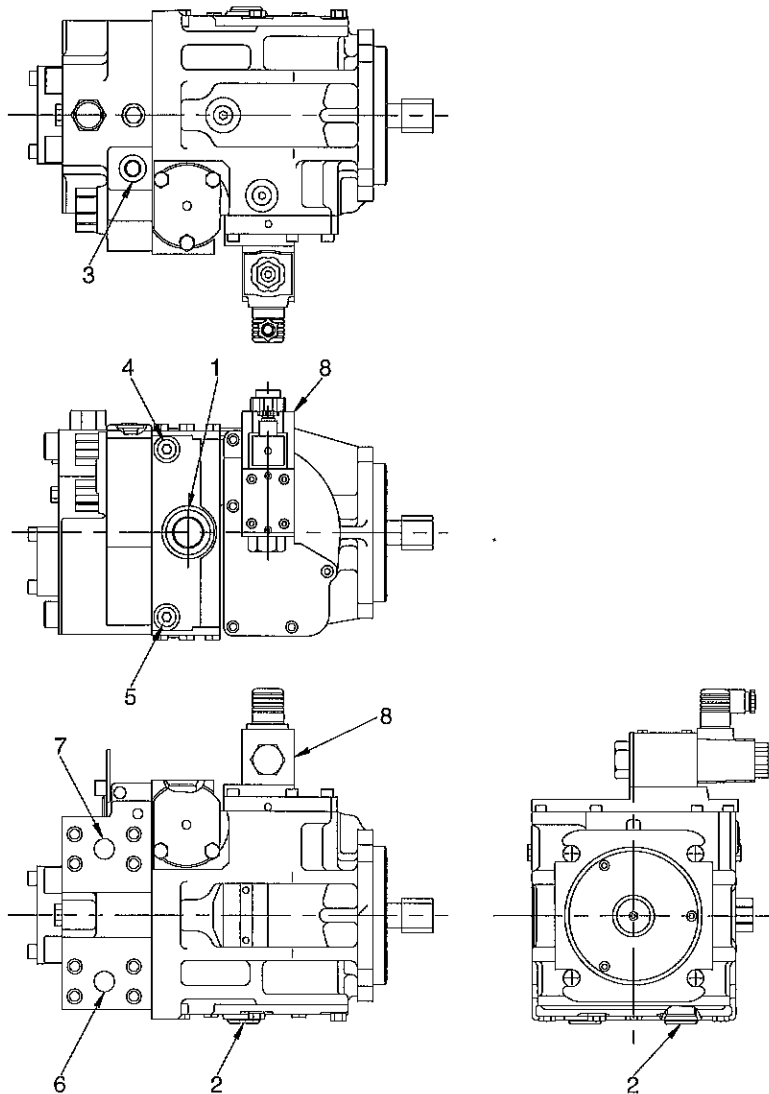

- | | |
|---------------------------------|---------------|
| (1) Drain port | : 1 1/16-12UN |
| (2) Drain port | : 1 1/16-12UN |
| (3) Pilot supply port | : 9/16-18UNF |
| (4) Servo pressure gauge port | : 9/16-18UNF |
| (5) Servo pressure gauge port | : 9/16-18UNF |
| (6) Port A (forward side) | : SAE 1" |
| (7) Port B (reverse side) | : SAE 1" |
| (8) Speed change solenoid valve | |

Specifications

- | | |
|------------------|---|
| • Model | : MV075-610 |
| • Displacement | |
| Maximum | : 75 cm ³ /rev (4.58 cu.in./rev) |
| Minimum | : 28 cm ³ /rev (1.71 cu.in./rev) |
| • Charge relief | |
| Pressure setting | : 2.67 MPa (387 psi) |
| • Weight | : 48 kg (106 lbs.) |

2-3-6. Differential lock valve

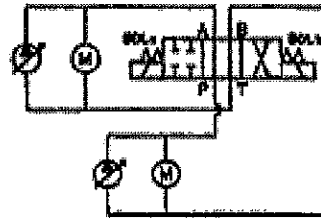
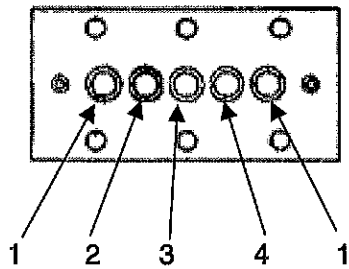
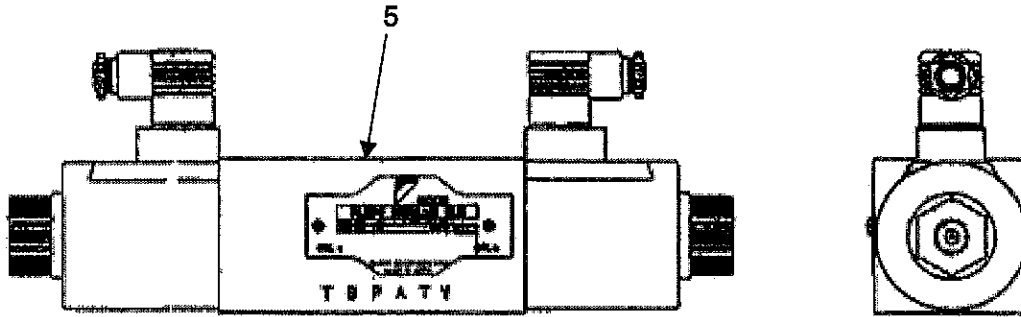

Hydraulic circuit diagram

- (1) Port T
- (2) Port B
- (3) Port P
- (4) Port A
- (5) Differential lock valve

Specifications

- Model : PFL-G-3-2HT-CP-20-C
- Maximum working pressure : 41.2 MPa (5974 psi)
- Maximum flow : 50 L/min (13.2 gal./min)
- Maximum switching speed : 120 times/minute (DC)
- Solenoid specifications : DC24V
- Weight : 7.5 kg (17 lbs.)

2-3-7. Manifold (for differential lock valve)

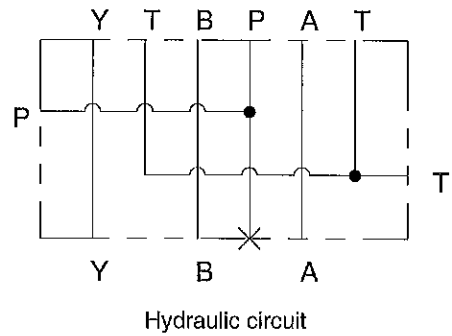
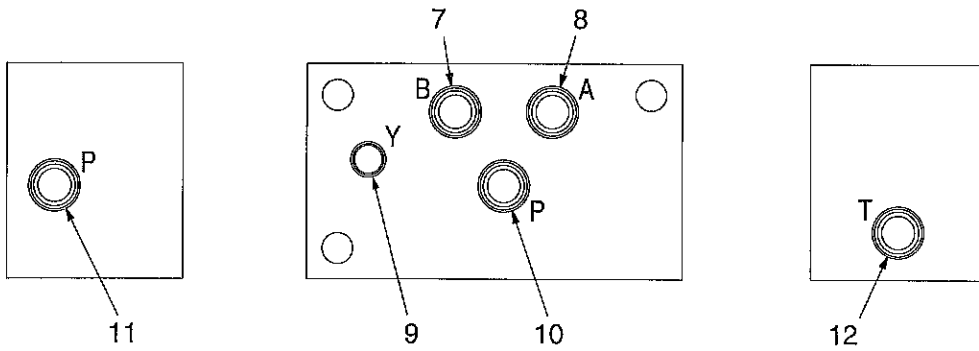
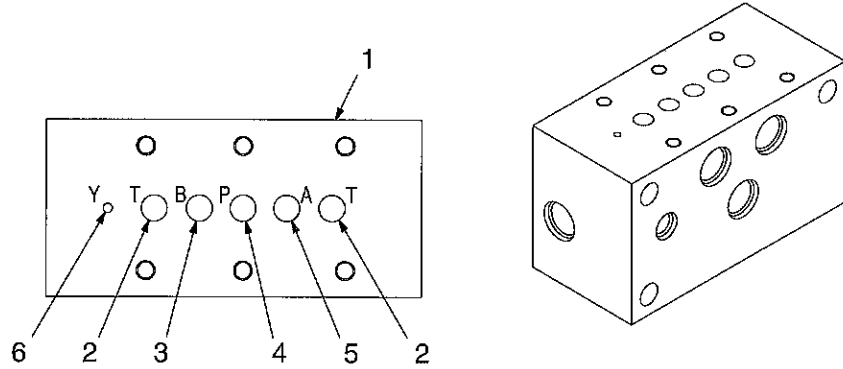

- | | | |
|--------------|-------------|---------|
| (1) Manifold | (7) Port B | : G1/2" |
| (2) Port T | (8) Port A | : G1/2" |
| (3) Port B | (9) Port Y | : G1/4" |
| (4) Port P | (10) Port P | : G1/2" |
| (5) Port A | (11) Port P | : G1/2" |
| (6) Port Y | (12) Port T | : G1/2" |

• Manifold weight: 8 kg (18 lbs.)

2-3-8. Flow dividing valve

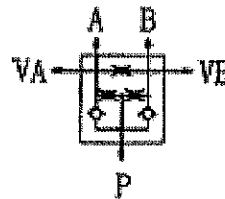
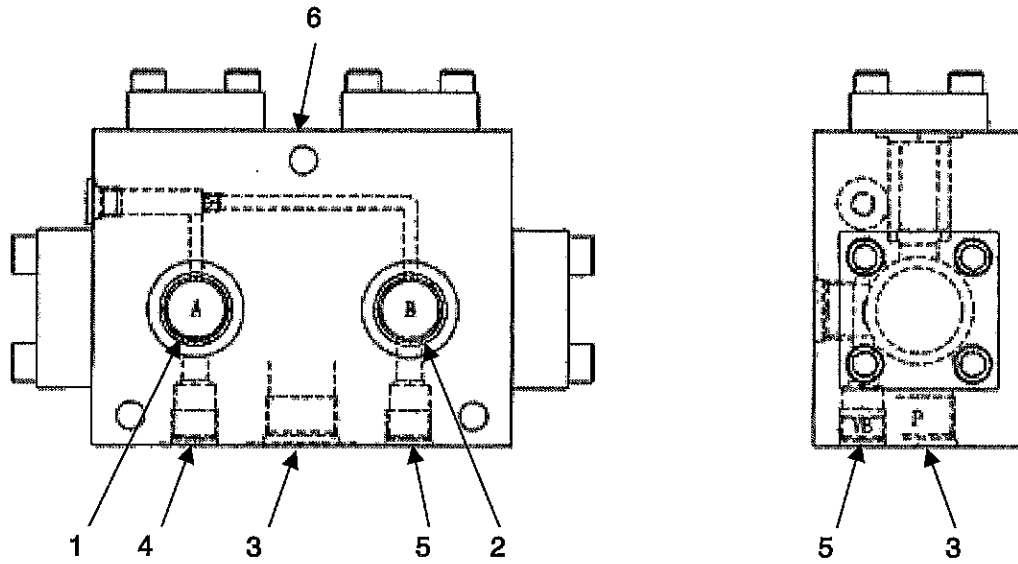

Hydraulic circuit

- (1) Port A : G3/4"
- (2) Port B : G3/4"
- (3) Port P : G1"
- (4) Port VA : G1/2"
- (5) Port VB : G1/2"
- (6) Flow dividing valve

Specifications

- Model : S-FDCT-08-150S
- Rated pressure : 41.5 MPa (6017.5 psi)
- Working flow : 0~180 L/min (0~47.6 gal./min)
- Control flow : 150 L/min (39.6 gal./min)
- Flow division ratio : A : B=1.65 : 1
- Weight : 22 kg (48.5 lbs.)

2-3-9. Internal structure of flow dividing valve

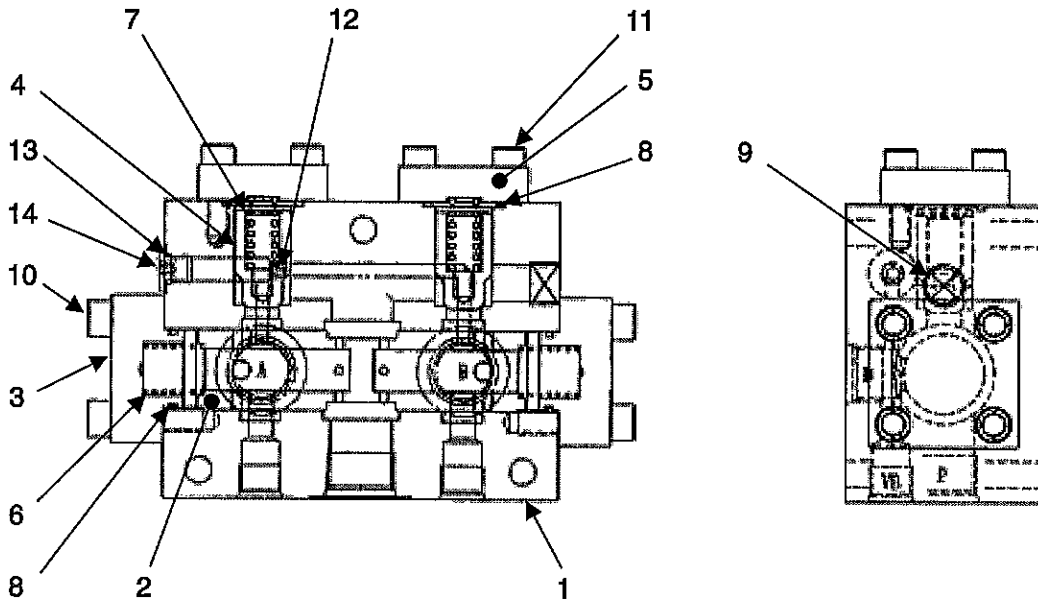

- | | | |
|-----------------|-------------------------------|------------|
| (1) Body | (8) O-ring | : 1BG 35 |
| (2) Spool | (9) Hexagon socket head plug | : PT1/2" |
| (3) Cover | (10) Hexagon socket head bolt | : M12 × 45 |
| (4) Check valve | (11) Hexagon socket head bolt | : M10 × 35 |
| (5) Check cover | (12) Damper | : φ1.2 |
| (6) Spring | (13) O-ring | : 1BP 11 |
| (7) Spring | (14) Plug | : G1/4" |

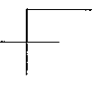
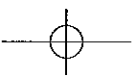
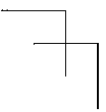
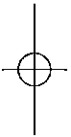
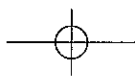
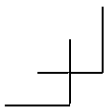

3. VIBRATOR HYDRAULIC SYSTEM

3-1. Vibrator hydraulic piping

- (1) Vibrator motor
 - (1-1) Port A
 - (1-2) Port B
 - (1-3) Drain port
- (2) Return filter
 - (2-1) O.U.T
 - (2-2) I.N
- (3) Propulsion pump
 - (3-1) Drain port
- (4) Vibrator pump
 - (4-1) Port B2
 - (4-2) Port A2
 - (4-3) Drain port
 - (4-4) Drain port
- (5) Hose
- (6) Hose
- (7) Hose
- (8) Hose
- (9) Hose
- (10) Hose

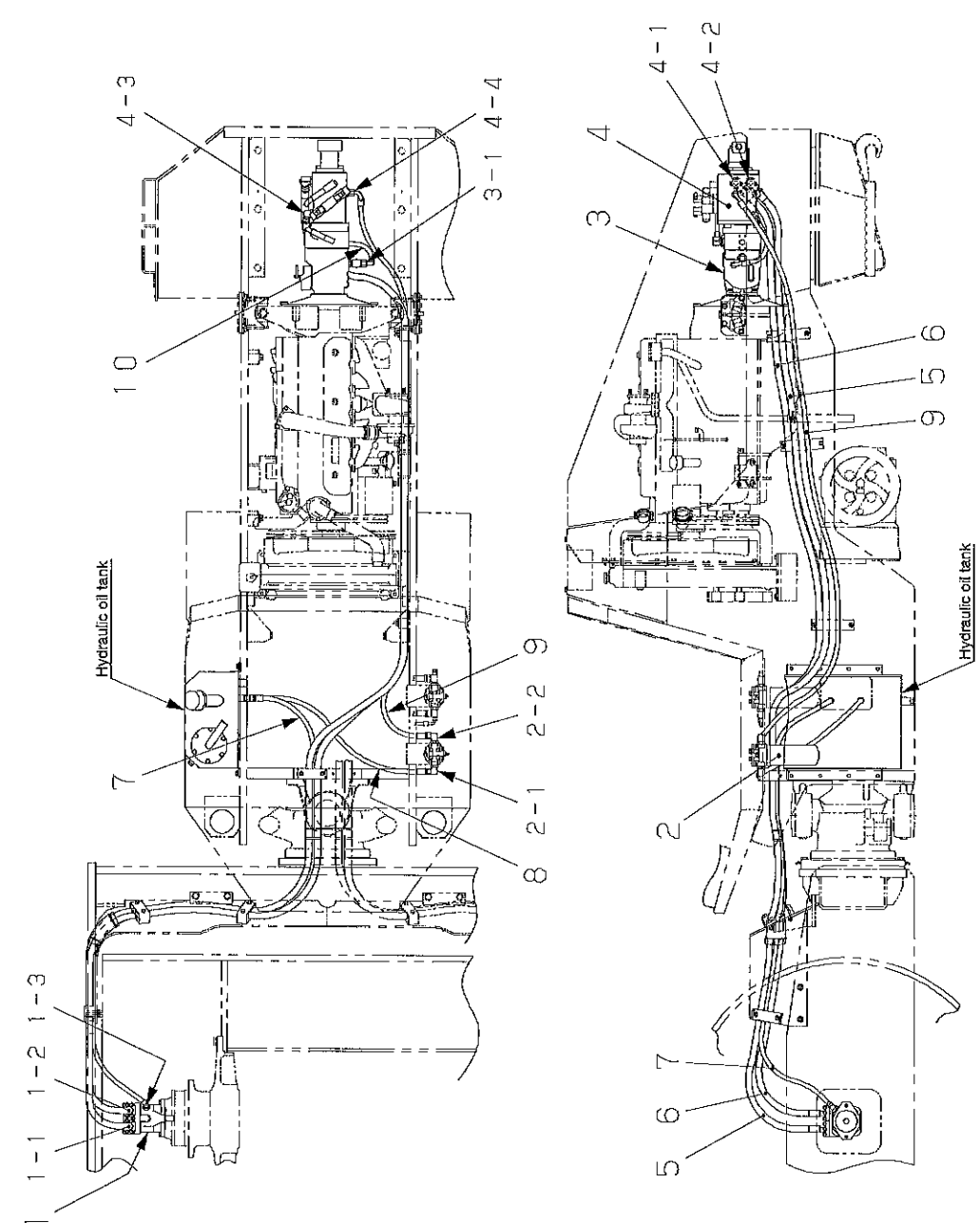

The figures (such as 1-1 and 2-1) show each port and the arrow (→) symbols show the hose connection and the direction of the flow of the oil.



Z00806510 142435



046_HYDRAULIC_~P4-016_A3.mpl 017



3-2. Hydraulic equipment specifications

3-2-1. Vibrator hydraulic motor

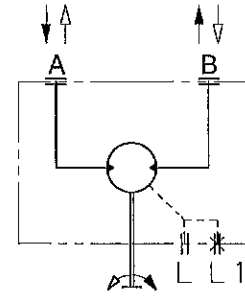
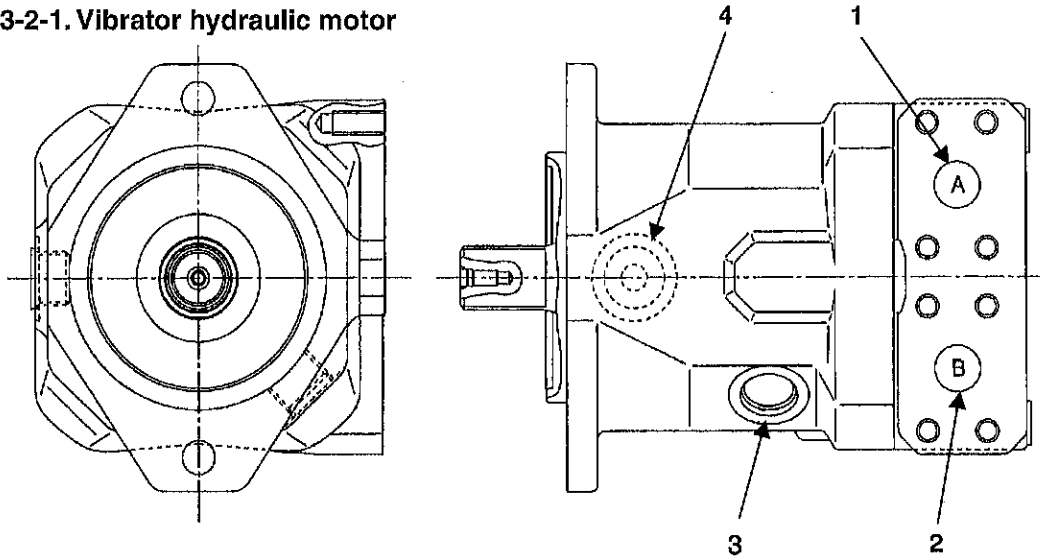

Hydraulic circuit diagram

Flow of oil

- A→B Clockwise rotation
- B→A Counterclockwise rotation

- | | |
|---------------------|---------------------------------|
| (1) Port A | : SAE 3/4" |
| (2) Port B | : SAE 3/4" |
| (3) Drain port (L) | : 7/8-14UNF-2B-15 |
| (4) Drain port (L1) | : 7/8-14UNF-2B-16 (Normal plug) |

Specifications

- | | |
|--------------------|--|
| · Model | : A10FM45/52W-VRC60N000 |
| · Displacement | : 44.5 cm ³ /rev (2.7 cu.in.) |
| · Working pressure | : 28.0 MPa (4060 psi) |
| · Weight | : 17 kg (37.5 lbs.) |

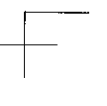
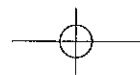
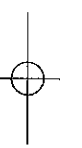
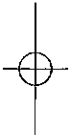
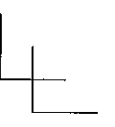
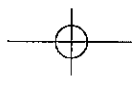

4. STEERING SYSTEM

4-1. Steering hydraulic piping (SV510D/TF-II)

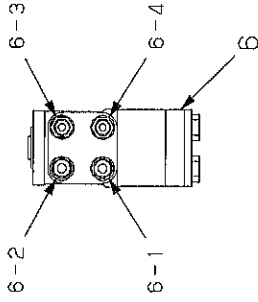
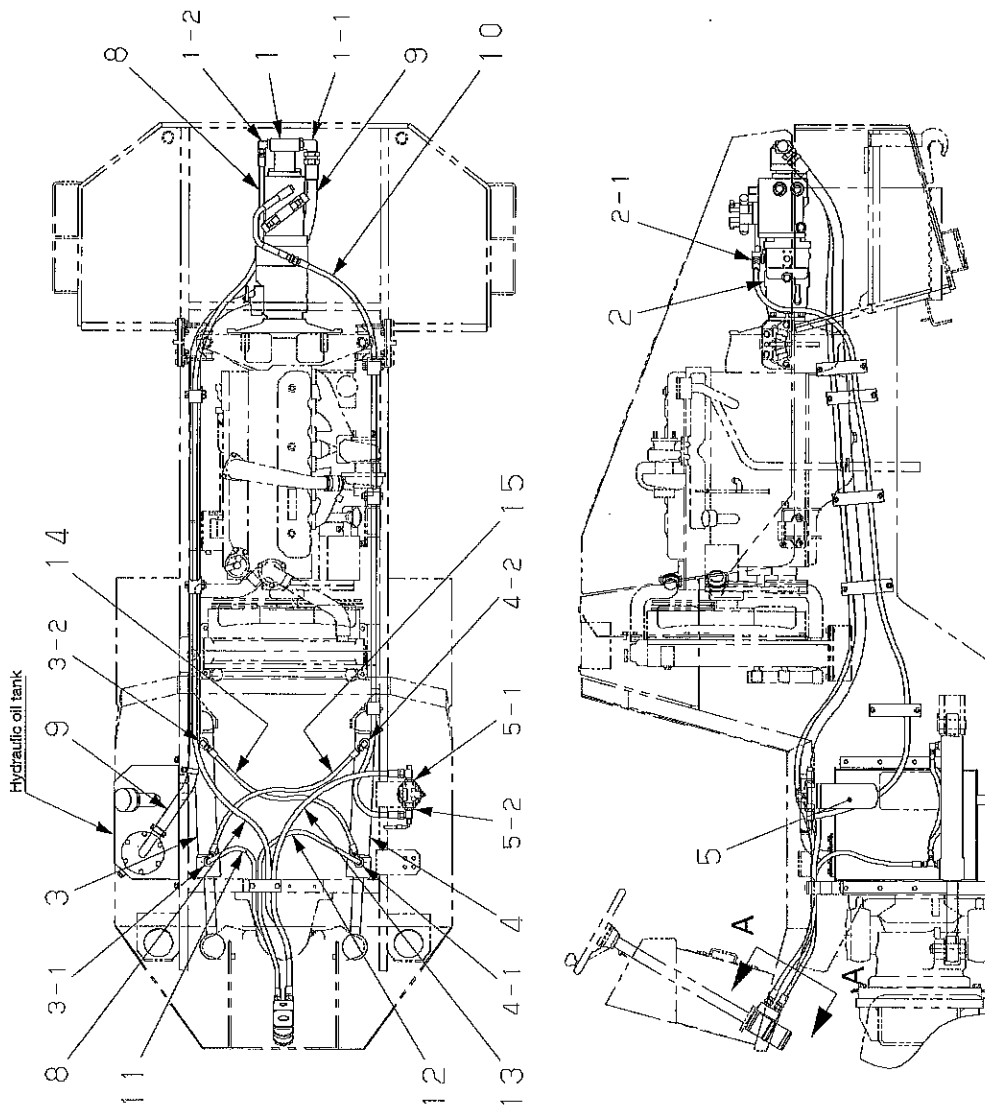

View A-A

- (1) Steering/charge pump
- (1-1) Suction port : G1"
- (1-2) Discharge port : G3/4"
- (2) Propulsion pump
- (2-1) Charge supply port : G1/2"
- (3) Power cylinder (R)
- (3-1) Port R1 : G3/8"
- (3-2) Port R2 : G3/8"
- (4) Power cylinder (L)
- (4-1) Port L1 : G3/8"
- (4-2) Port L2 : G3/8"
- (5) Line filler
- (5-1) IN : G3/4"
- (5-2) OUT : G3/4"
- (6) Orbital
- (6-1) Port P : 3/4-16UNF
- (6-2) Port T : 3/4-16UNF
- (6-3) Port L : 3/4-16UNF
- (6-4) Port R : 3/4-16UNF
- (8) Hose : (1-2)→(6-1)
- (9) Hose : Hydraulic oil tank→(1-1)
- (10) Hose : (5-2)→(2-1)
- (11) Hose : (6-4)→(3-1)
- (12) Hose : (6-3)→(4-1)
- (13) Hose : (6-2)→(5-1)
- (14) Hose : (4-1)→(3-2)
- (15) Hose : (3-1)→(4-2)

* The figures (such as 1-1 and 2-1) show each port and the arrow (→) symbols show the hose connection and the direction of the flow of the oil.



2008/06/10 14:25:13



045_HYDRAULIC_P401D_A.indd 019



4-2. Steering hydraulic piping (SV510TB/TFB-II)

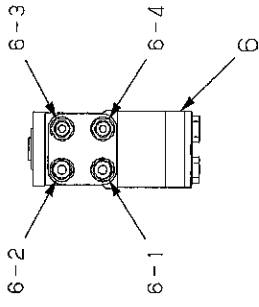
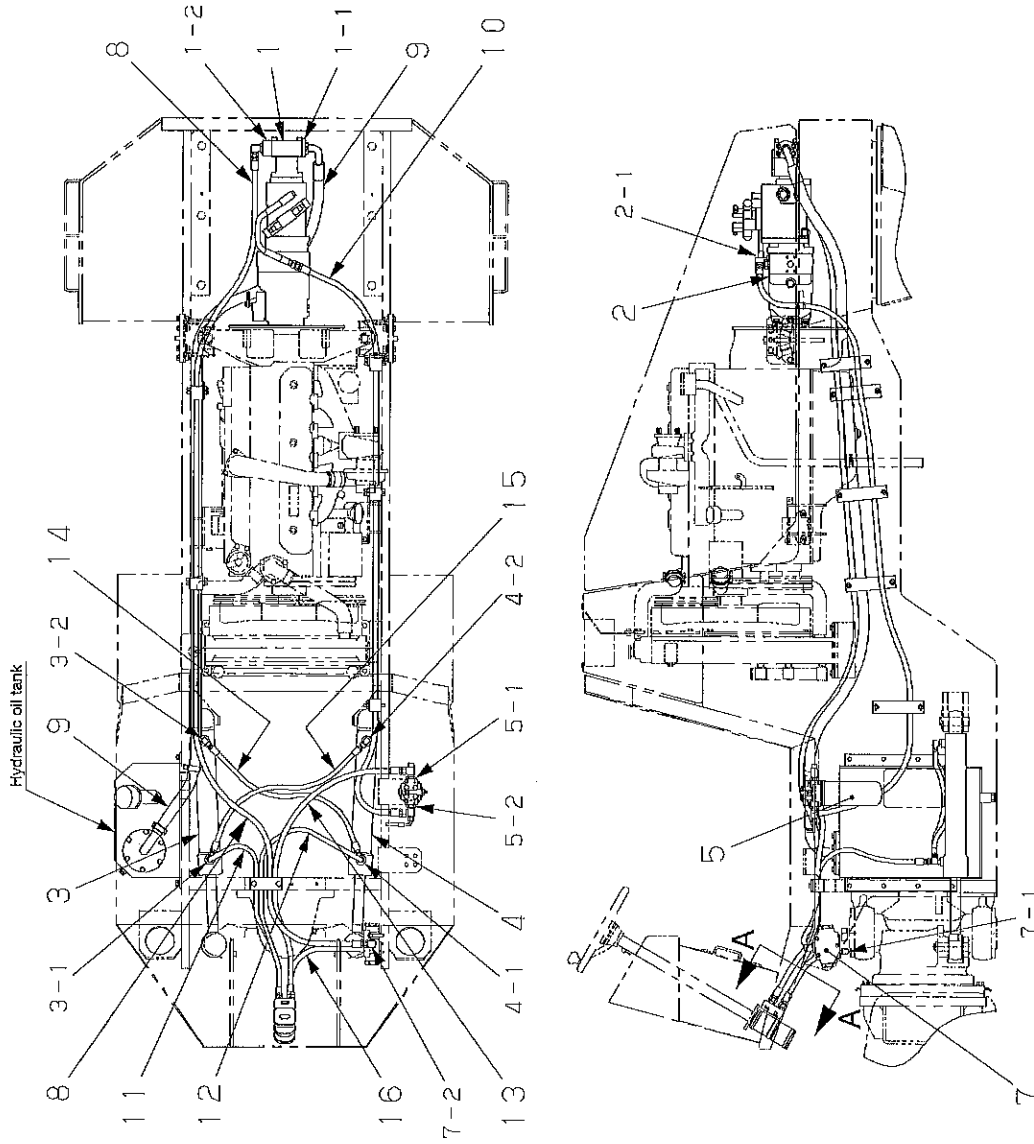

View A-A

- (1) Steering/charge pump
 - (1-1) Suction port : G1"
 - (1-2) Discharge port : G3/4"
- (2) Propulsion pump
 - (2-1) Charge supply port : G1/2"
- (3) Power cylinder (R)
 - (3-1) Port R1 : G3/8"
 - (3-2) Port R2 : G3/8"
- (4) Power cylinder (L)
 - (4-1) Port L1 : G3/8"
 - (4-2) Port L2 : G3/8"
- (5) Line filter
 - (5-1) IN : G3/4"
 - (5-2) OUT : G3/4"
- (6) Orbital
 - (6-1) Port P : 3/4-16UNF
 - (6-2) Port T : 3/4-16UNF
 - (6-3) Port L : 3/4-16UNF
 - (6-4) Port R : 3/4-16UNF
- (7) Flow dividing valve
 - (7-1) Port A : G1/2"
 - (7-2) Port P : G1/2"
- (8) Hose
 - (9) Hose : (1-2)→(7-2)
 - (10) Hose : (5-2)→(2-1)
 - (11) Hose : (6-4)→(3-1)
 - (12) Hose : (6-3)→(4-1)
 - (13) Hose : (6-2)→(5-1)
 - (14) Hose : (4-1)→(3-2)
 - (15) Hose : (3-1)→(4-2)
 - (16) Hose : (6-1)→(7-1)

• The figures (such as 1-1 and 2-1) show each port and the arrow (←→) symbols show the hose connection and the direction of the flow of the oil.



2008/06/10 14:28:11

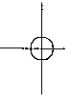
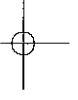

016_HYDRAULIC_P4-D10_A3.indd 56:020



4-3. Frame (center pin)

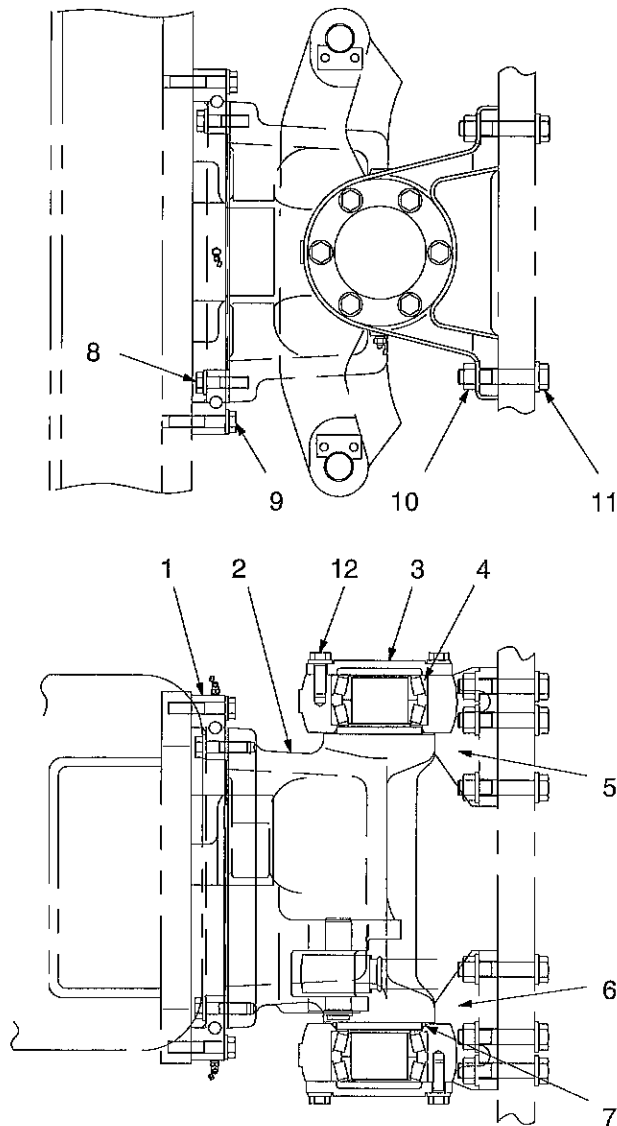

(1) Swing bearing

(2) Yoke

(3) Cover

(4) Roller bearing

(5) Bracket (top side)

(6) Bracket (bottom side)

(7) O-ring : P-112



(8) Bolt M16×60 : 265 N·m (195 lbf·ft)

(9) Bolt M16×80 : 265 N·m (195 lbf·ft)

(10) Nut M20 : 539 N·m (398 lbf·ft)

(11) Bolt M20×110

(12) Bolt M16×45 : 265 N·m (195 lbf·ft)

• Center pin assembly weight : 200 kg (441 lbs.)

STEERING SYSTEM

4-4. Steering wheel

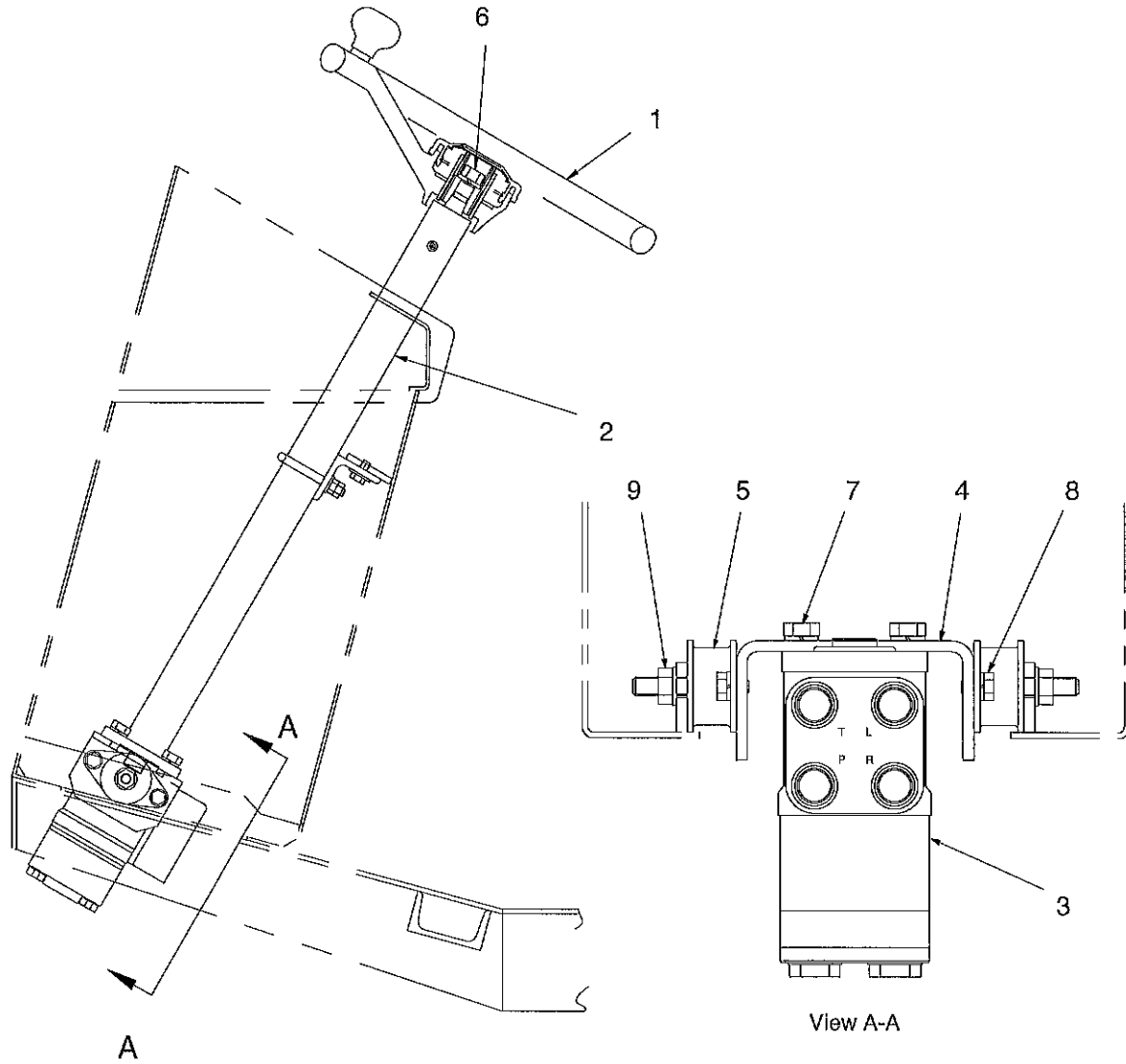

- (1) Steering wheel
- (2) Column shaft
- (3) Orbitrol
- (4) Bracket
- (5) Damper



- (6) Nut M14 P=1.5 : 137 N·m (101 lbf·ft)
- (7) Bolt M10×30 : 49 N·m (36 lbf·ft)
- (8) Bolt M 8×12 : 23 N·m (17 lbf·ft)
- (9) Nut M10 : 49 N·m (36 lbf·ft)

· Steering wheel assembly weight: 5 kg (11 lbs.)

4-4-1. Steering valve (Orbitrol)

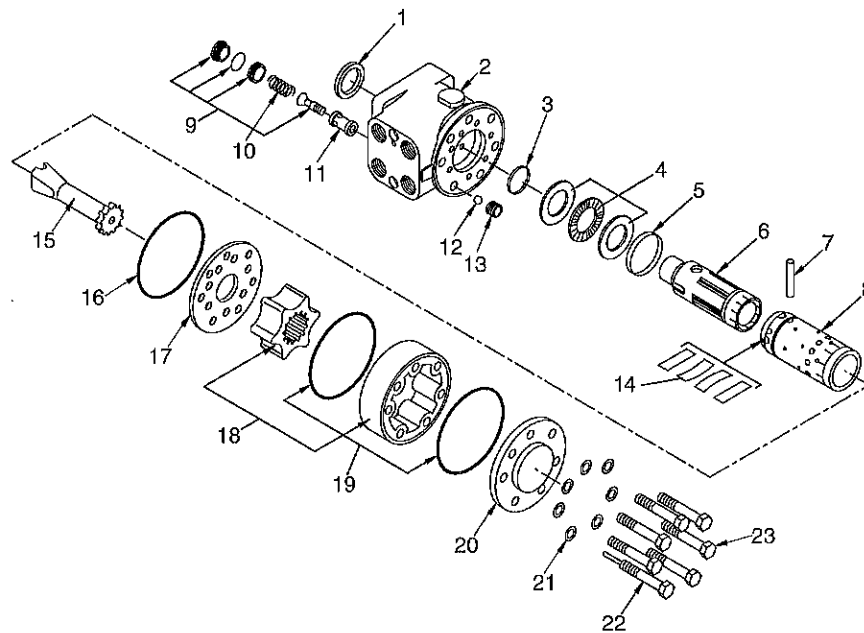
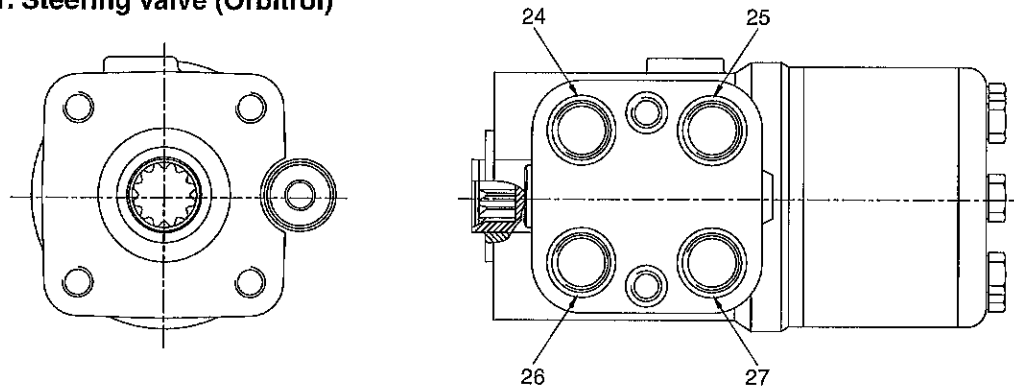

- | | | |
|----------------------|--------------|-------------------------|
| (1) Dust seal | (10) Spring | (19) O-ring |
| (2) Housing | (11) Seat | (20) Cover |
| (3) O-ring | (12) Ball | (21) Washer |
| (4) Bearing assembly | (13) Bushing | (22) Screw pin |
| (5) Ring | (14) Spring | (23) Screw |
| (6) Sleeve | (15) Shaft | (24) Port L : 3/4-16UNF |
| (7) Pin | (16) O-ring | (25) Port R : 3/4-16UNF |
| (8) Spool | (17) Plate | (26) Port T : 3/4-16UNF |
| (9) Relief valve | (18) G-rotor | (27) Port P : 3/4-16UNF |

Specifications

- Model : OSPC 400 ON
- Displacement : 400 cm³/rev (24.4 cu.in./rev)
- Relief valve pressure setting : 15.0 MPa (2175 psi)
- Weight : 8 kg (18 lbs.)

4-5. Steering cylinder

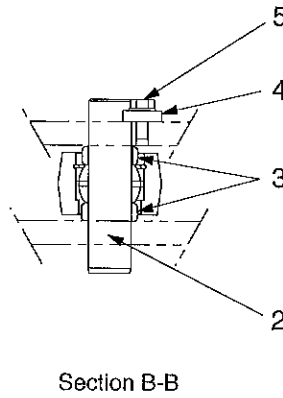
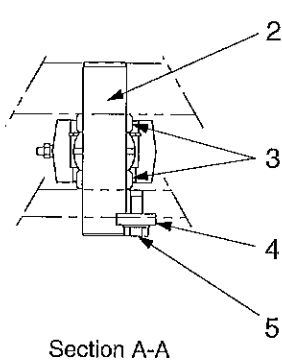
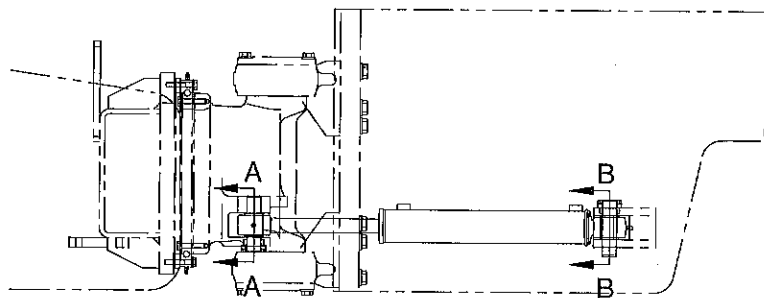
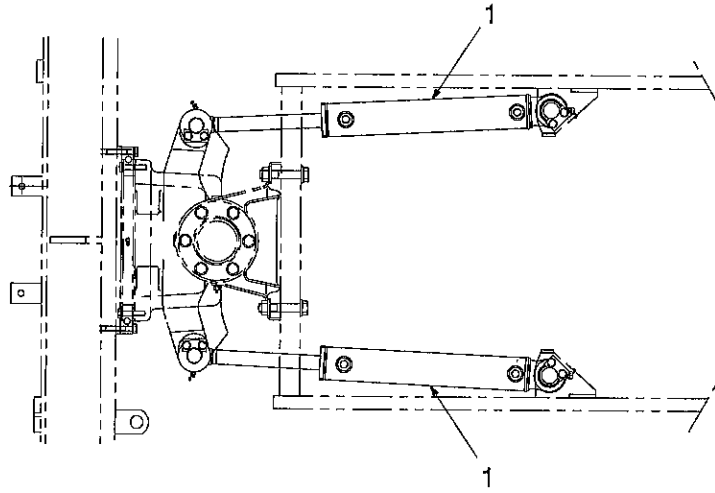

(1) Steering cylinder

(2) Pin

(3) Collar

(4) Plate

 N·m

(5) Bolt M10×25: 49 N·m (36 lbf·ft)

4-5-1. Internal structure of steering cylinder

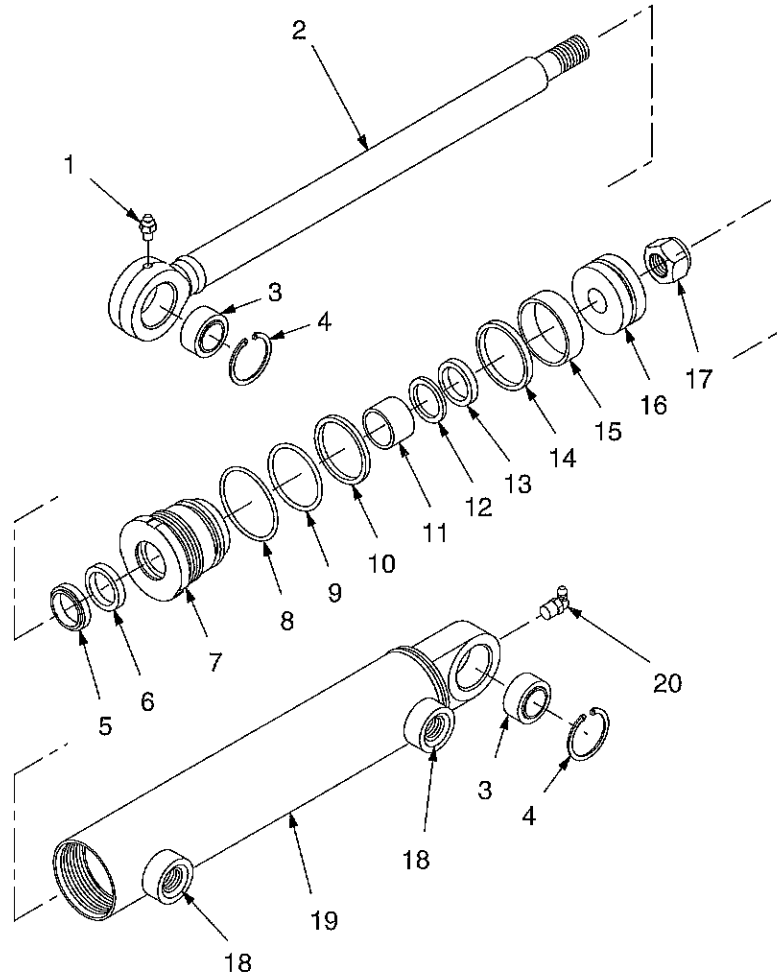

- (1) Grease nipple : R1/8
- (2) Rod
- (3) Spherical bearing
- (4) Snap ring
- (5) Dust seal
- (6) Stopper
- (7) Rod cap
- (8) O-ring : G-70
- (9) O-ring : G-65
- (10) Backup ring

- (11) Bush
- (12) Packing
- (13) Backup ring
- (14) Slip seal
- (15) Ring wear
- (16) Piston
- (17) Nylon nut : M24
- (18) O-ring port : G3/8
- (19) Tube
- (20) Grease nipple : R1/8

Specifications

- Maximum working pressure : 17.2 MPa (2488 psi)
- Stroke : 380 mm (15 in.)
- Weight : 21 kg (46 lbs.)

-  (17) Nylon nut : M24 382~559 N·m
(282~412 lbf·ft)

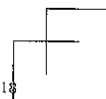
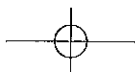
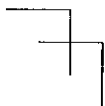
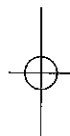
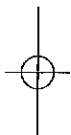
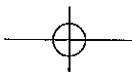
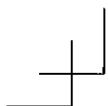

5. BLADE

5-1. Blade hydraulic piping (SV510TB/TFB-II)

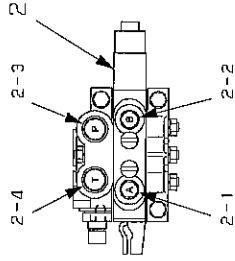
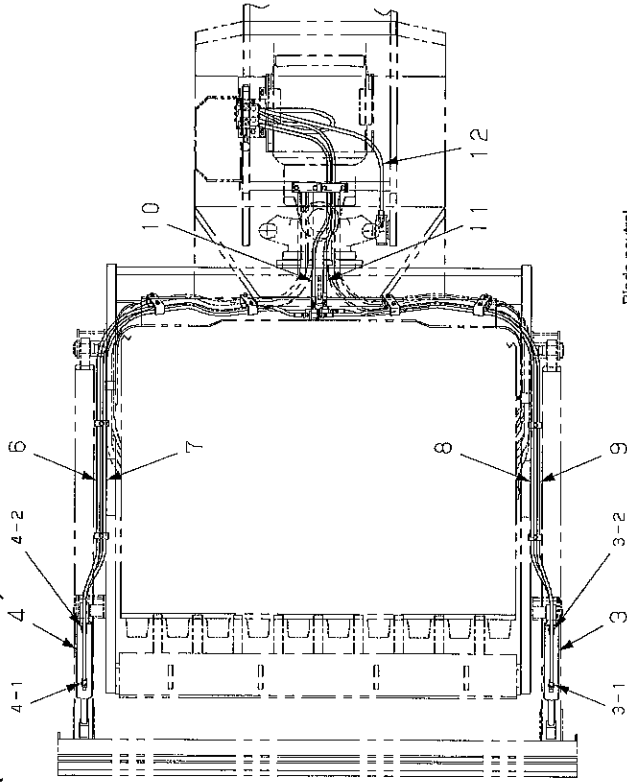

View A-A

- (1) Control lever : G1/2"
- (2) Control valve : G1/2"
- (2-1) Port A (up side) : G1/2"
- (2-2) Port B (down side) : G3/4"
- (2-3) Port P : G3/4"
- (2-4) Port T : G3/4"
- (3) Power cylinder (L) : G3/8"
- (3-1) Port L1 (up side) : G3/8"
- (3-2) Port L2 (down side) : G3/8"
- (4) Power cylinder (R) : G3/8"
- (4-1) Port R1 (up side) : G3/8"
- (4-2) Port R2 (down side) : G3/8"
- (5) Flow dividing valve : G1/2"
- (5-1) Port B : G1/2"
- (6) Hose : (4-1) → (10)
- (7) Hose : (4-2) → (11)
- (8) Hose : (3-2) → (11)
- (9) Hose : (3-1) → (10)
- (10) Hose : (3-1) (4-1) → (2-1)
- (11) Hose : (3-2) (4-2) → (2-2)
- (12) Hose : (2-3) → (5-1)
- (13) Hose : (2-4) → Hydraulic oil tank

• The figures (such as 1-1 and 2-1) show each port and the arrow (→) symbols show the hose connection and the direction of the flow of the oil.

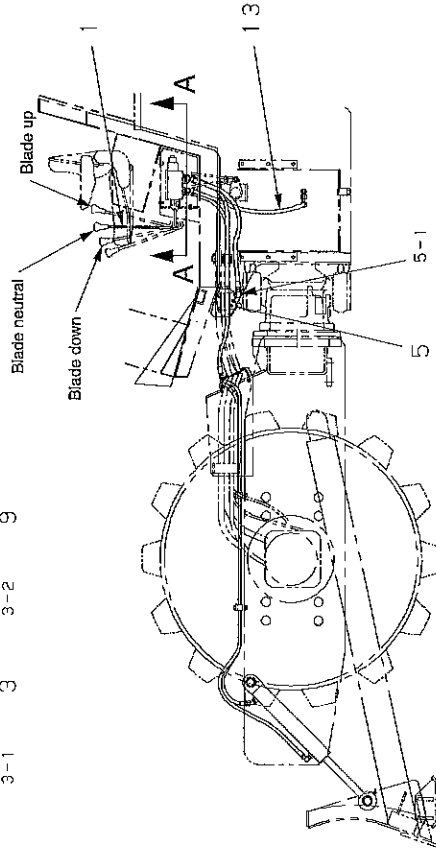



2008/06/10 14:32:28

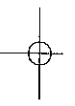

01E_11103A111C_14025_45.mh 028



5-2. Hydraulic equipment specifications

5-2-1. Control valve

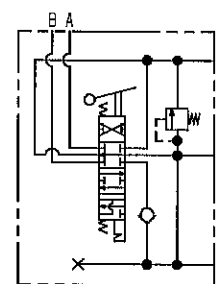
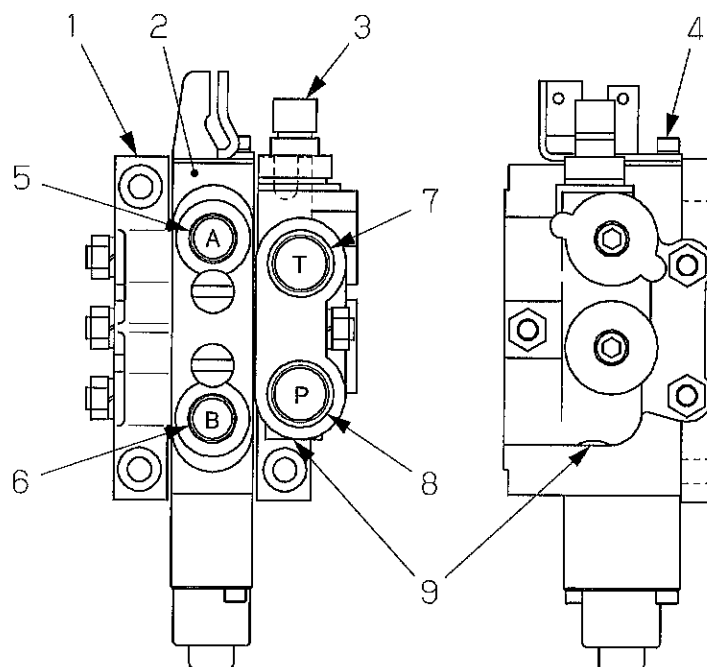

Hydraulic circuit diagram

| | | |
|--------------------------|---|---------|
| (1) End cover | (5) Port A (cylinder port) | : G1/2" |
| (2) F block assembly | (6) Port B (cylinder port) | : G1/2" |
| (3) Inlet cover assembly | (7) Port T (tank port) | : G3/4" |
| (4) L block assembly | (8) Port P (pump port) | : G3/4" |
| | (9) Port G (pressure gauge connection port) | : RC1/4 |

Specifications

| | |
|--------------------------------|---|
| · Model | : SV11-F-L-7 · F |
| · Maximum working pressure | : 20.6 MPa (2987 psi) |
| · Rated flow | : 70 L/min (18.5 gal./min) |
| · Main relief pressure setting | : 13.7 MPa (1987 psi) at 30 L/min (8 gal./min) |
| · Weight | : 6.6 kg (14.6 lbs.) |

5-2-2. Internal structure of cylinder

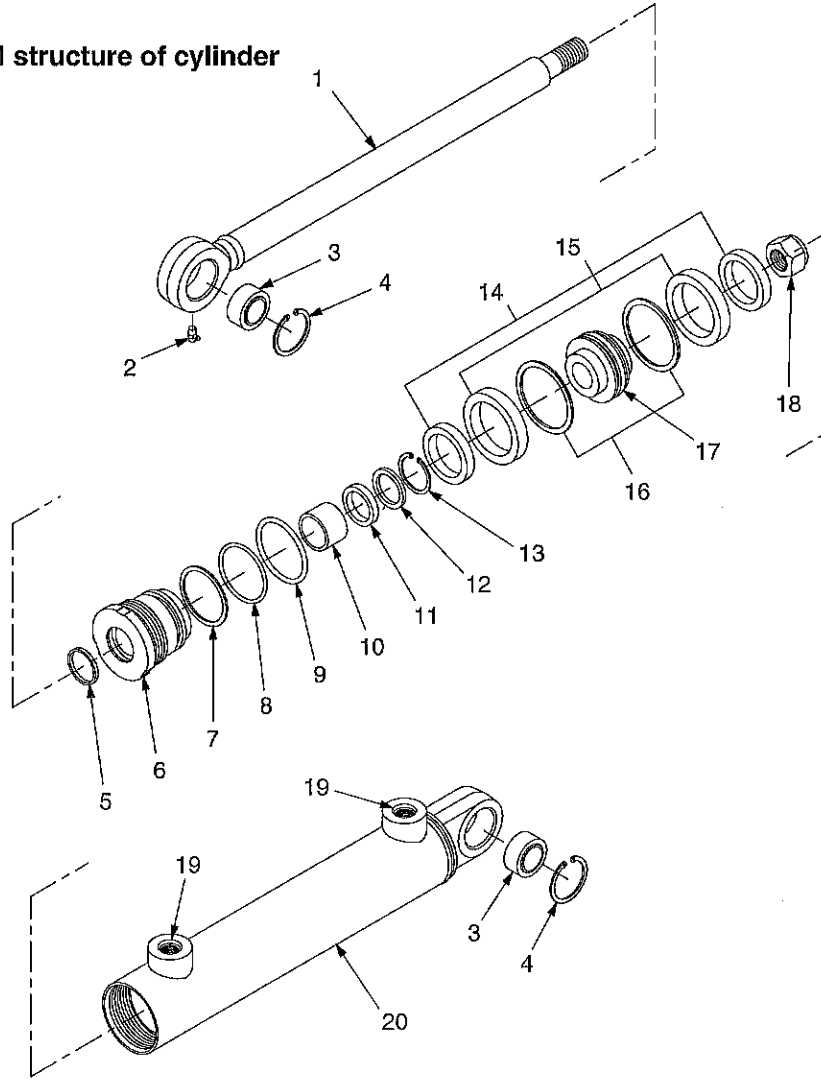

- | | | | |
|-----------------------|--------|----------------------|--------|
| (1) Rod | | (11) U-ring | |
| (2) Grease nipple | : R1/8 | (12) Packing | |
| (3) Spherical bearing | | (13) Snap ring | |
| (4) Snap ring | | (14) U-ring holder | |
| (5) Wiper ring | | (15) U-ring assembly | |
| (6) Cylinder head | | (16) Piston ring | |
| (7) Lock washer | | (17) Piston | |
| (8) O-ring | : G-75 | (18) U-nut | : M24 |
| (9) O-ring | : P-70 | (19) O-ring port | : G3/8 |
| (10) Bush | | (20) Tube | |

Specifications

- Relief valve pressure setting : 13.7 MPa (1991 psi)
- Stroke : 330 mm (13 in.)
- Weight : 17 kg (37.5 lbs.)



- | | | |
|------------|-------|------------------|
| (18) U-nut | : M24 | 382~559N·m |
| | | (282~412 lbf·ft) |

4-027

5-2-3. Flow dividing valve

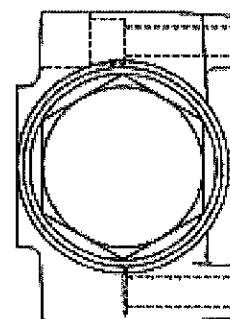
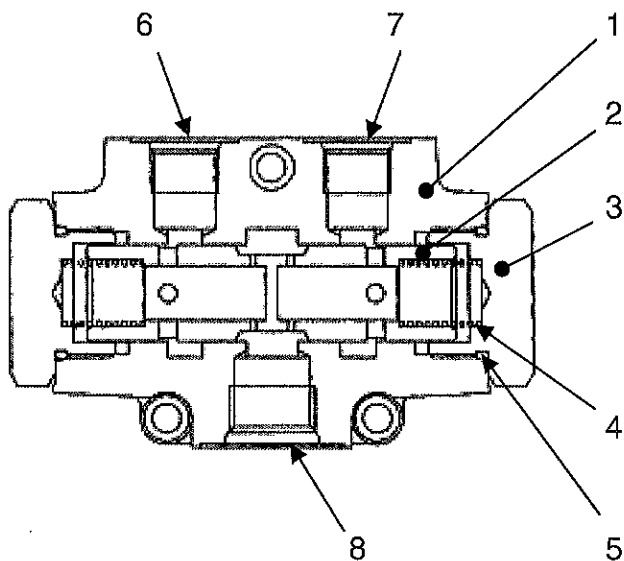

Hydraulic (oil) pressure symbol

| | |
|------------|----------|
| (1) Body | |
| (2) Spool | |
| (3) Cover | |
| (4) Spring | |
| (5) O-ring | : 1BP 36 |
| (6) Port A | : G1/2" |
| (7) Port B | : G1/2" |
| (8) Port P | : G3/4" |

Specifications

| | |
|-----------------------|--------------------------|
| • Model | : FDT-06-60S (2 : 1) |
| • Rated pressure | : 29.4 MPa (4263 psi) |
| • Standard flow | : 60 L/min (16 gal./min) |
| • Flow division ratio | : A : B = 2 : 1 |
| • Weight | : 5 kg (11 lbs.) |

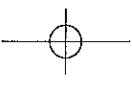
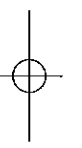
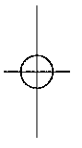
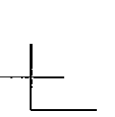
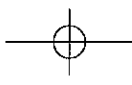
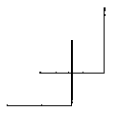



ELECTRICAL SYSTEM



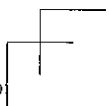
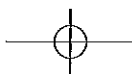
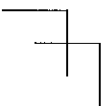
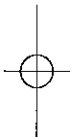
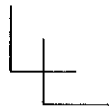
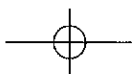

1. GENERAL SYSTEM CIRCUIT DIAGRAM

1-1. Electrical wiring diagram

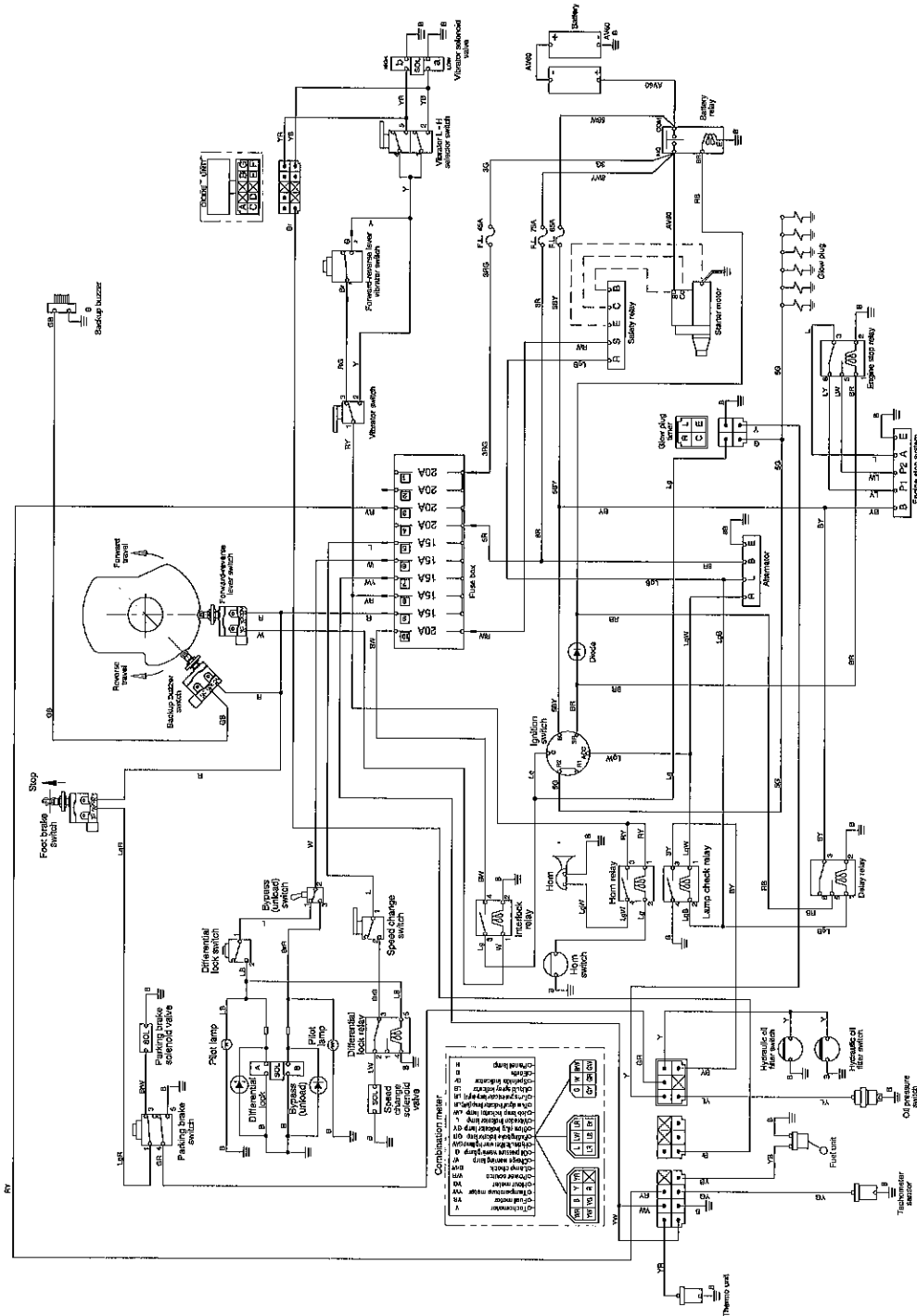



2009/09/11 10:45:04



05B_ELECTRICAL_PS-01_A3.indd 002



2. ELECTRICAL COMPONENTS

2-1. Electrical component layout (1)

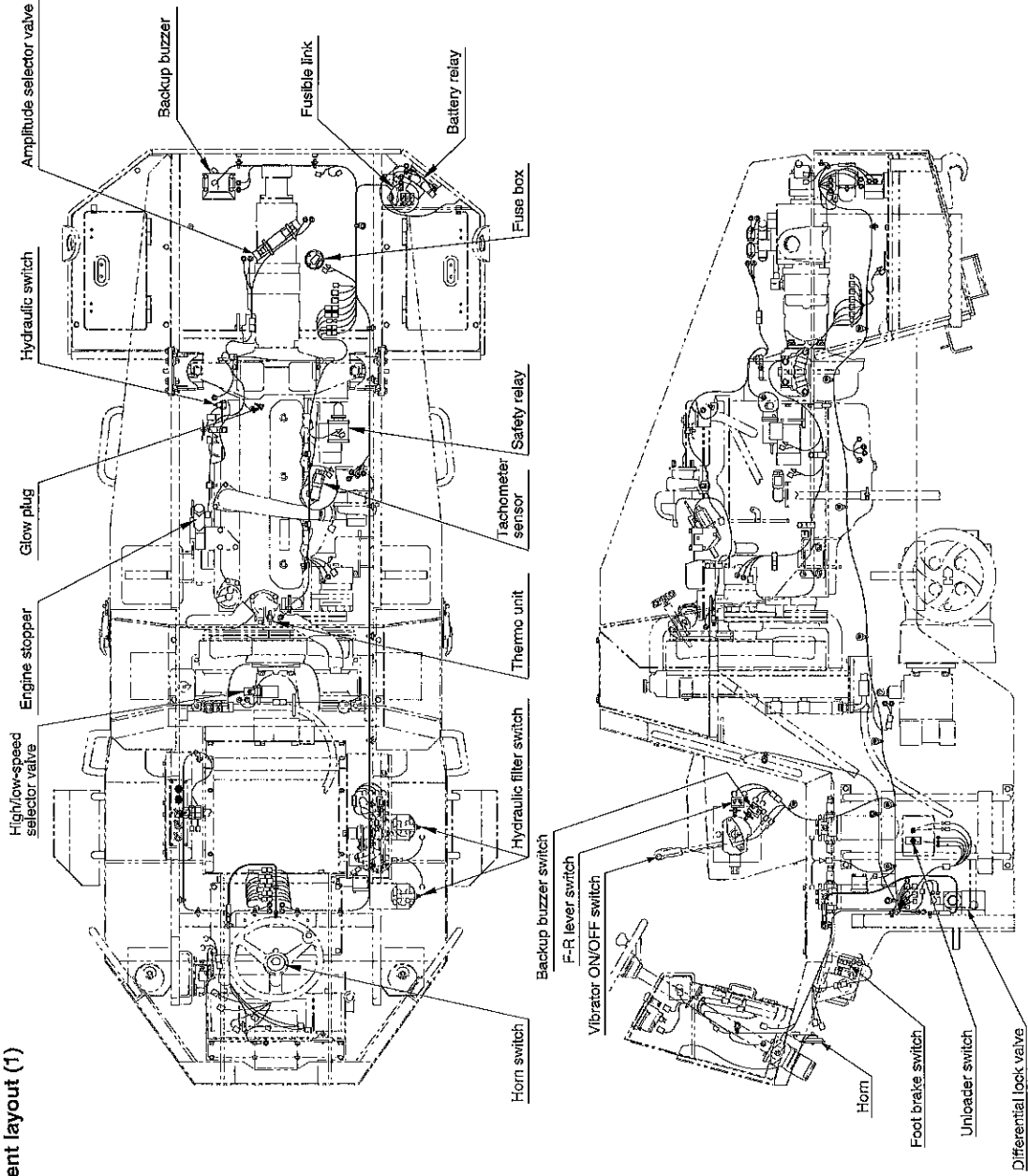



2008/05/10 14:43:25



D5A4_ELECTRICAL_PSE012_A3.indd 013



2-2. Electrical component layout (2)

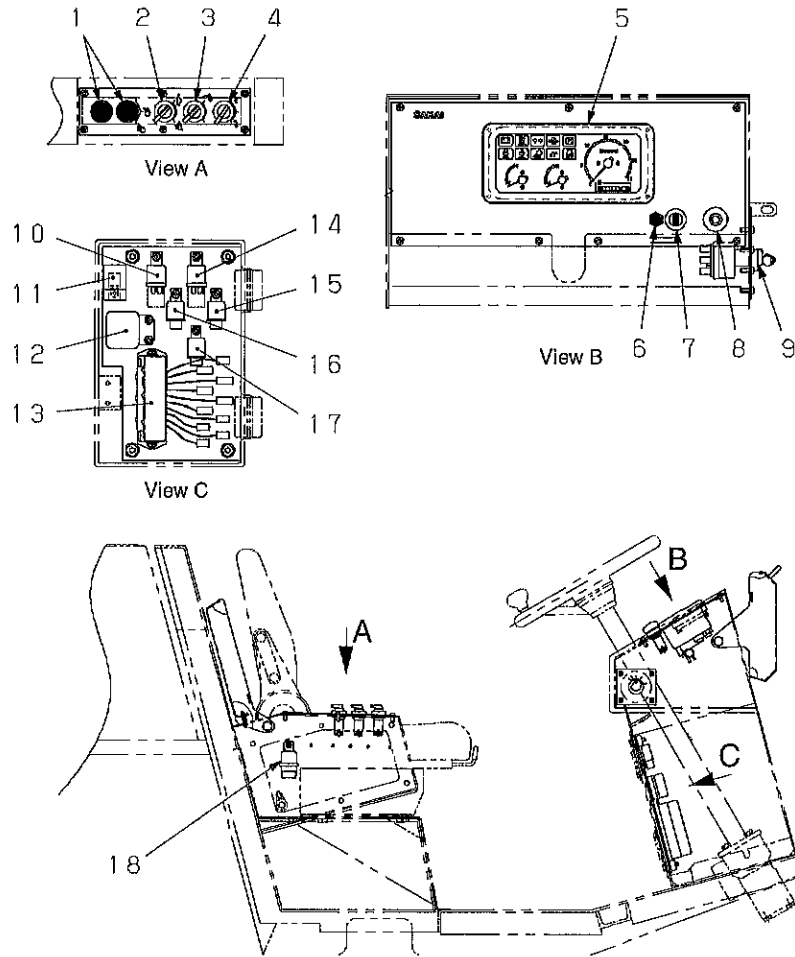

- | | |
|--------------------------------------|------------------------------|
| (1) Cover | (10) Engine stop relay |
| (2) Speed change switch | (11) Diode unit |
| (3) Vibrator switch | (12) Glow timer |
| (4) Vibrator L - H selector switch | (13) Fuse box |
| (5) Combination meter | (14) Delay relay |
| (6) Pilot lamp for differential lock | (15) Lamp check relay |
| (7) Differential lock switch | (16) Interlock relay |
| (8) Parking brake switch | (17) Horn relay |
| (9) Ignition switch | (18) Differential lock relay |

2-3. Battery layout

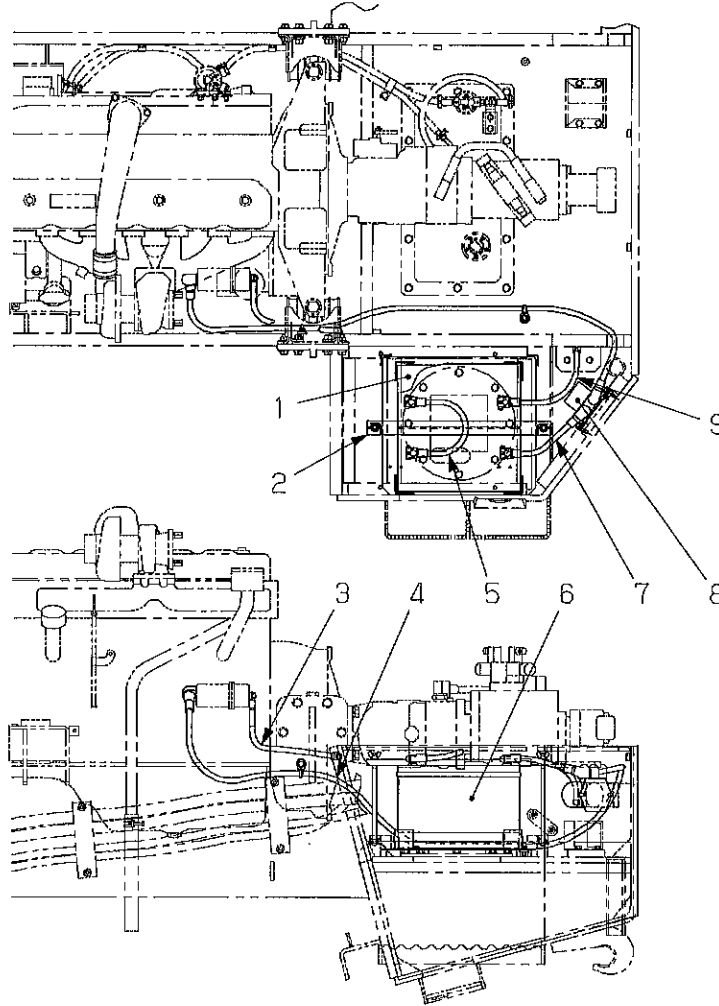

- | | |
|--|---|
| (1) Cushion | (6) Battery |
| (2) Plate (lauan) | (7) Battery cable : L=250 mm (9.8 in.) |
| (3) Battery cable (+) | (8) Battery relay |
| (4) Battery cable : L=1600 mm (63 in.) | (9) Battery cable : L=350 mm (13.8 in.) |
| (5) Battery cable : L= 350 mm (13.8 in.) | |

3. ELECTRICAL COMPONENT SPECIFICATIONS

3-1. Fuse box

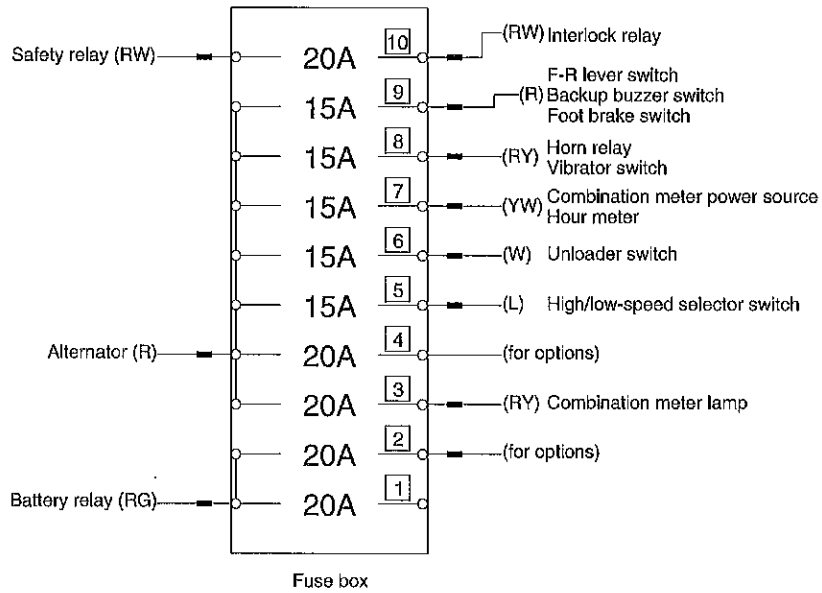
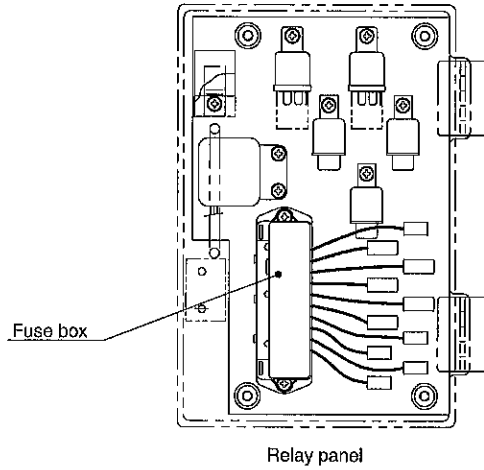

Harness colors and symbols

- | | |
|-------------------------|---------------------------|
| R : Red | W : White |
| RW : Red/white striped | L : Blue |
| RG : Red/green striped | YW : Yellow/white striped |
| RY : Red/yellow striped | |

ELECTRICAL COMPONENT SPECIFICATIONS

3-2. Engine stop system

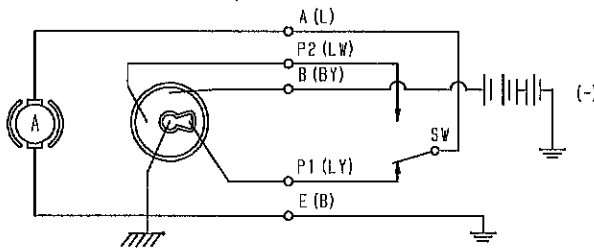
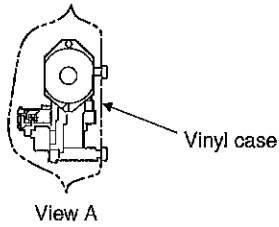
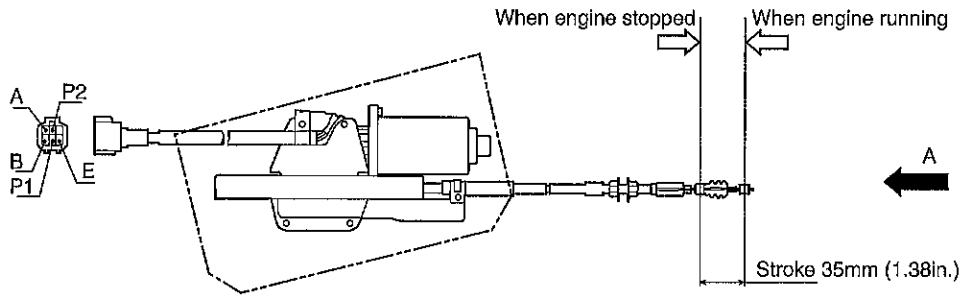

Internal circuits

Harness colors and symbols

- L : Blue
- LW : Blue/White striped
- BY : Black/Yellow striped
- LY : Blue/Yellow striped
- B : Black

Specifications

- Rated voltage : 24 V
- Spring pressure : When set 6 ± 2 kg (13.2 ± 4.4 lbs.)
: When stretched 5 mm (stretched 0.2 in.) 10 kg (22.0 lbs.)
- Current : 1.5 A or less when there is no load
: 11 A or less when locked
- Stroke : 35 mm (1.38 in.)
- Operating time : 1 second or less
- Weight : 1.2 kg (2.65 lbs.)

3-2-1. Engine stopper functions and operation

Functions

- Can start and stop the engine simply by operating the ignition switch.
- The equipment consists of the engine stopper and engine stop relay.

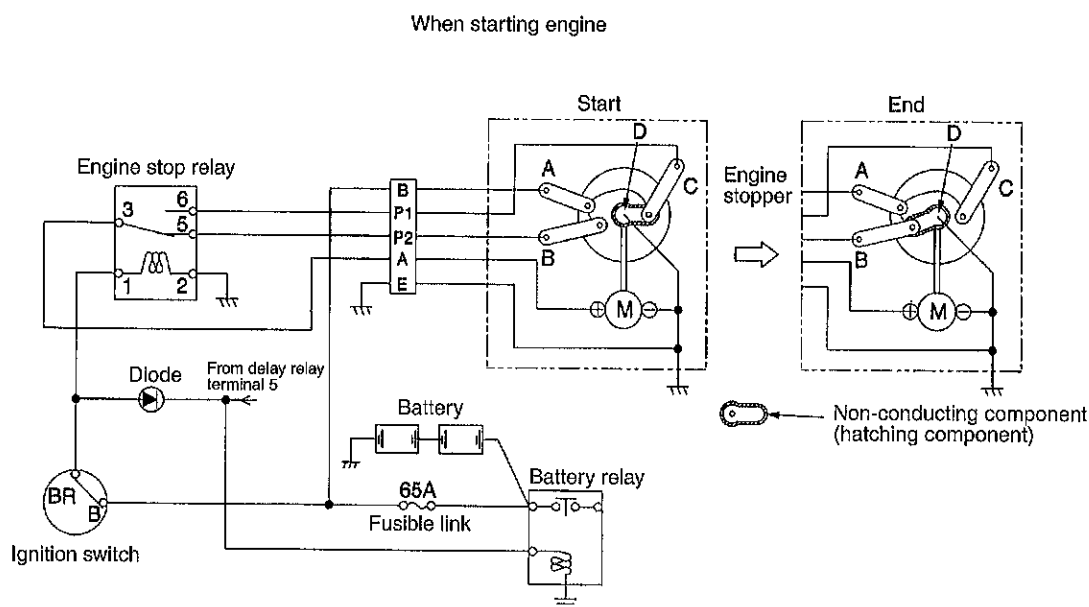

Operation

When starting

- Turn the ignition switch to ON.
- Ignition switch terminal B and terminal BR become electrically connected.
- Engine stop relay is actuated.
- Battery relay => engine stopper terminal A => terminal B => engine stop relay terminal 5 => terminal 3 => flows to engine stopper motor (+) terminal then rotates the motor (control cable extends)
- Motor rotation and terminal D rotation at same time.
- Non-conducting portion of terminal D reaches terminal B.
- Circuit between terminals A and B opens.
- Current from battery is cut off.
- Inertia causes the motor to continue to rotate.
- Conducting portion of the terminal makes contact with terminal B.
- Both electrodes of the motor connects with the ground, and the motor stops rotating.
- Control cable extends completely.
- Injection pump's stop lever is held in the operation position.
- Engine is in condition to operate.

ELECTRICAL COMPONENT SPECIFICATIONS

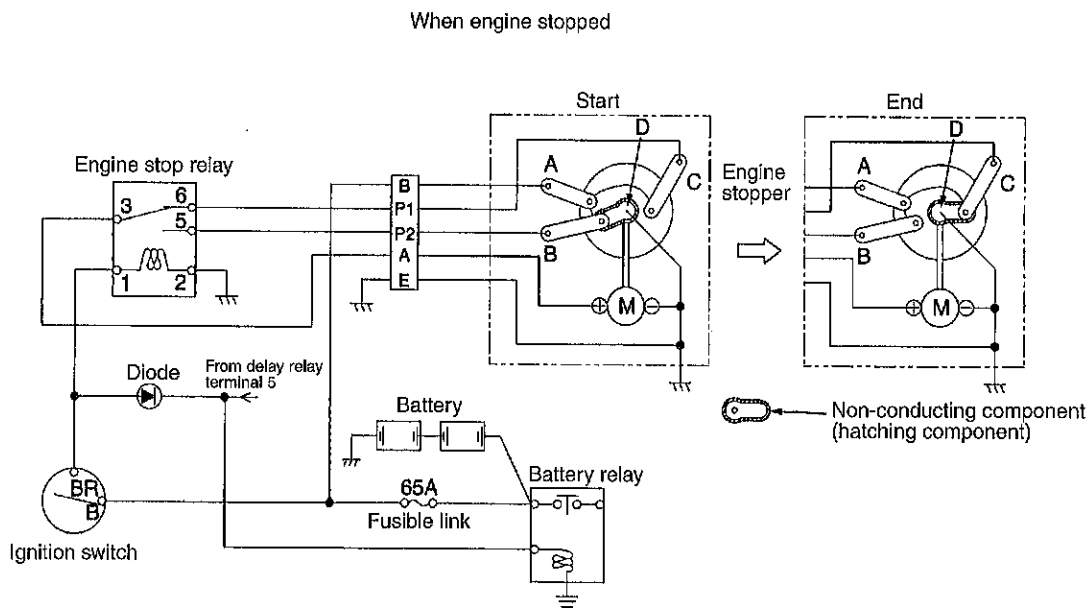

When stopping

- Turn the ignition switch to OFF.
- Electrical continuity between ignition switch terminal B and terminal BR is cut off.
- Excitation of the engine stop relay is cut off.
- Battery relay => engine stopper terminal A => terminal C => engine stop relay terminal 6 => terminal 3 => flows to engine stopper motor (+) terminal then rotates the motor (control cable withdraws)
- Motor rotation and terminal D rotation at same time.
- Non-conducting portion of terminal D reaches terminal C.
- Circuit between terminals A and C opens.
- Current from battery is cut off.
- Inertia causes the motor to continue to rotate.
- Conducting portion of the terminal makes contact with terminal C.
- Both electrodes of the motor connects with the ground, and the motor stops rotating.
- Control cable withdraws completely.
- Injection pump's stop lever is held in the stop position.
- Fuel is cut off, and the engine stops.

3-3. Diode unit

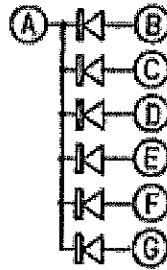
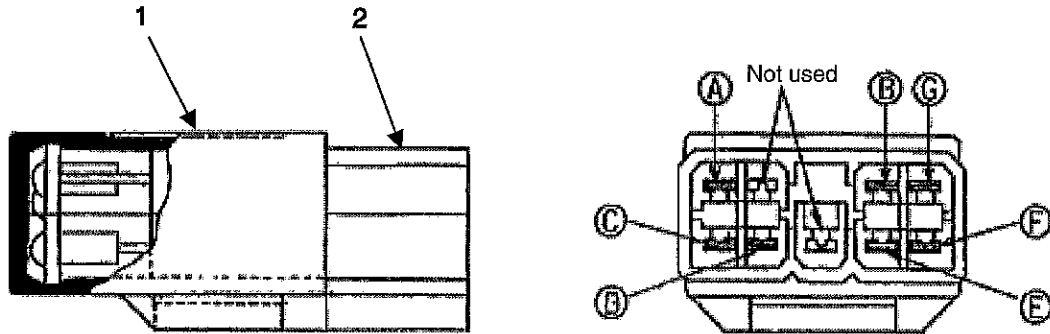

Schematic diagram

- (1) Cover : rubber (SC610-CP black)
 (2) Connector COMP : YAZAKI No.7118-3090-60

Specifications

- Maximum peak inverse withstand voltage : 100 V
- Maximum mean rectified current : 1 A
- Maximum surge current : 50 A
- Insulation resistance : At least 3 MΩ with a 500 VM insulation tester between each connector terminal and cover
- Storage/operating temperature : -30 °C ~ 75 °C (-22 °F ~ 167 °F)

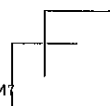
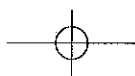
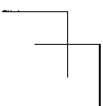
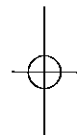
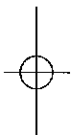
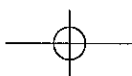
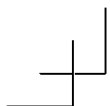

VIBRATORY DRUM · REAR AXLE

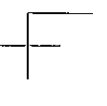
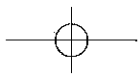
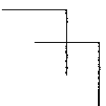
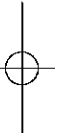
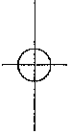
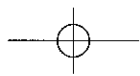
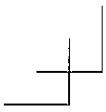

1. PRECAUTIONS FOR DISASSEMBLY AND REASSEMBLY

- When removing, installing, disassembling or reassembling the unit, observe the general precautions described below.

1) Precautions for removal work

- Coolant that contains antifreeze should be treated as a chemical, and must not be drained carelessly on the ground.
- To prevent dust from getting into disconnected hoses and tubes, cover them with a plug or similar means.
- When draining oil, use a receptacle with sufficient capacity to receive it.
- Before proceeding with the work, look for matchmarks that show the installation location. For reassembly, place matchmarks in the required locations to prevent errors. Then remove.
- When disconnecting wiring connectors, hold the connector components so that unreasonable force is not applied to the wires.
- Label wires and hoses to ensure correct installation location.
- Confirm the number and thickness of shims prior to storage.
- When lifting parts, use lifting equipment of sufficient capacity.
- When separating parts by using pull bolts, tighten the bolts alternately.
- Before removing a unit, clean its surrounding area. Then after removal, cover it to prevent dust and other substances from getting in.
- Before removing piping for hydraulic oil or coolant, or removing related parts, satisfactorily release internal pressure.

2) Precautions for installation work

- Tighten bolts and nuts (sleeve nuts) to the specified torque (screw tightening torque table).
- When installing hoses, do not twist them or allow them to interfere with other parts.
- Replace gaskets, O-rings, split cotter pins, and lock plates with new parts.
- Properly bend split cotter pins and lock plates.
- When applying an adhesive, first clean and remove oil/grease from the surfaces properly. Then apply two or three drops to the threaded areas.
- When applying a liquid gasket, first clean and remove oil/grease from the application surface properly, and confirm that the surface is free of dust and damage. Then apply the product evenly.
- Clean parts well. Repair scratches, dents, burrs, rust, etc.
- Apply gear oil to rotating and sliding components.
- Apply grease to the surfaces of press-fit parts.
- After installing snap rings, confirm that they are properly seated in the grooves.
- Connect wiring connectors securely after cleaning off adhering oil, dust and water.
- Use lifting bolts that are not fatigued or deformed. Screw them in fully.
- When tightening a split flange, tighten screws alternately to prevent uneven tightening.
- Before installing hydraulic parts, confirm that they are free of damage and dust, etc.



PRECAUTIONS FOR DISASSEMBLY AND REASSEMBLY

3) Precautions when work is completed

- If coolant has been drained, securely retighten the drain cock and fill with coolant (mixing in long-life coolant) to the specified level. Start the engine and allow the coolant to circulate through the piping. Then add coolant again to the specified level.
- If hydraulic equipment has been removed and reinstalled, fill with hydraulic oil to the specified level. Start the engine and allow the oil to circulate through the piping. Then add oil again to the specified level.

2. VIBRATORY DRUM

2-1. Removal and installation of vibratory drum

2-1-1. Removal of vibratory drum

- 1) Using the steering lock bar (1), connect the front and rear frames. Firmly secure it so that the front and rear frames do not move.

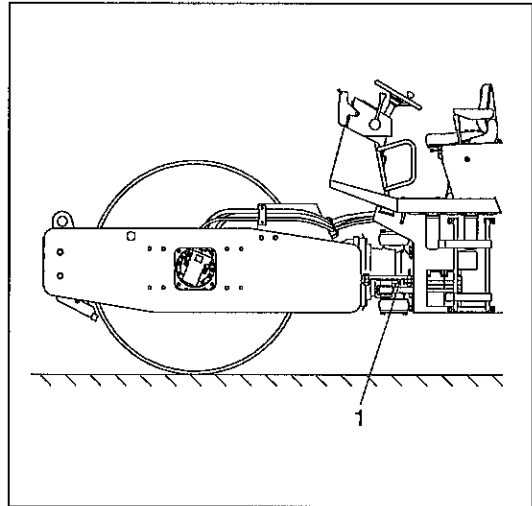

- 2) As shown in the figure on the right, lift the rear frame with a crane. Firmly secure the vehicle body by placing support stands and/or wooden blocks at the rear end of the rear frame.

★ **Do not allow the rear wheel tires to leave the ground. (The tires must support the vehicle's body weight, too.)**

 Rear axle weight: 5,150 kg (11,350 lbs.)

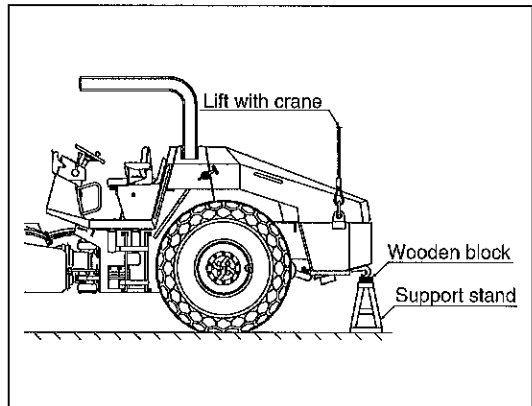

WARNING

When lifting the vehicle, use an appropriate hoist of sufficient strength. Confirm that the surrounding area is safe, and work in a natural, unstrained posture.

Also, to firmly secure the vehicle body, use a support stand of sufficient strength.

- 3) Lift the front frame with a crane. With the drum slightly above the ground surface, place support stands at the right and left sides of the front frame. Firmly secure the vehicle body.

 Front axle weight

| | |
|-------------|--------------------------|
| SV510D-II | : 5,820 kg (12,830 lbs.) |
| SV510T-II | : 6,180 kg (13,630 lbs.) |
| SV510TB-II | : 6,750 kg (14,880 lbs.) |
| SV510TF-II | : 8,440 kg (18,610 lbs.) |
| SV510TFB-II | : 9,020 kg (19,885 lbs.) |

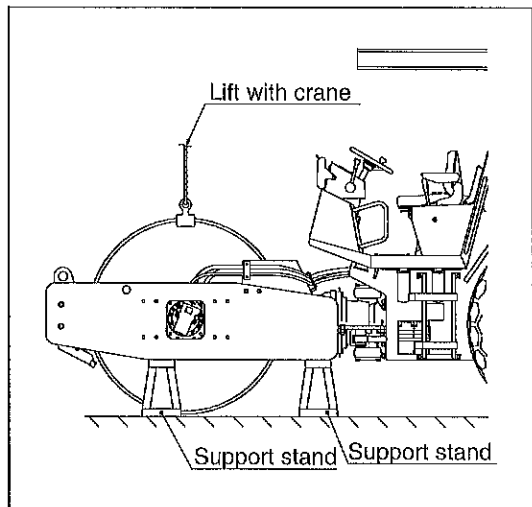

VIBRATORY DRUM

- 4) With the crossmember (3) lifted by the crane, loosen the two bolts (2) (both right and left). Then remove the cross member from the front frame.

| | | |
|---|----------------|-----------------------|
|  Crossmember | SV510D-II | : 500 kg (1,120 lbs.) |
| | SV510T/TB-II | : 580 kg (1,300 lbs.) |
| | SV510TF/TFB-II | : 650 kg (1,450 lbs.) |

• When installing

 (2) M20X110: 539 N·m (398 lbf·ft)

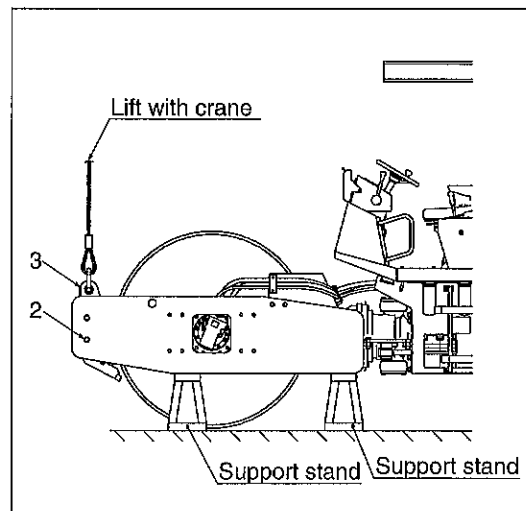

- 5) Disconnecting piping
- ① Propulsion motor piping
Disconnect the hydraulic hoses (4, 5 and 6) that are connected to the propulsion motor.

★ Either plug both sides of disconnected connections or take other steps to prevent dust from getting inside.

WARNING

Immediately after the vehicle has stopped, the hydraulic oil will be hot and under built-up pressure. If, under these conditions, you try to disconnect the piping, you may get burned. Therefore, wait until the oil has cooled before engaging in this task.

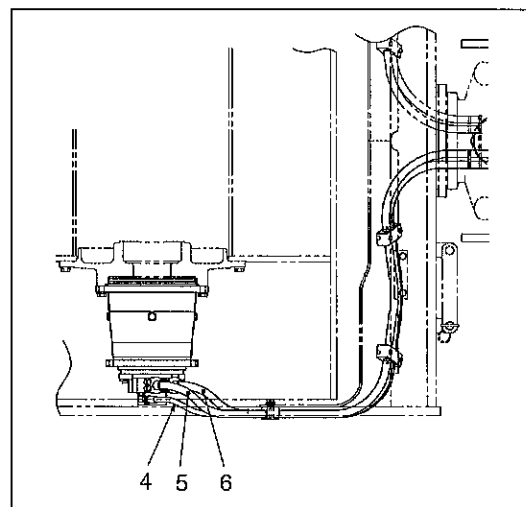

- ② Vibrator motor piping
Disconnect the hydraulic hoses (7, 8 and 9) that are connected to the vibrator motor.

★ Either plug both sides of disconnected connections or take other steps to prevent dust from getting inside.

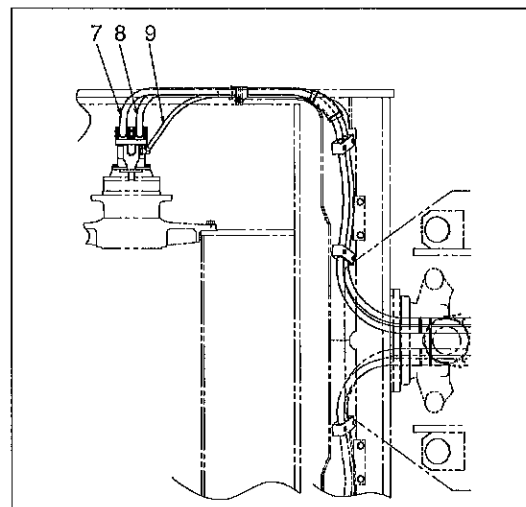

VIBRATORY DRUM

- 6) Loosen and remove the two bolts (11) (both right and left).
- Lift the drum (12) with a crane. Ensuring that no load is applied to the eight bolts (10), loosen and remove the bolts (10). (Similarly, remove the bolts from the opposite side, too.) Separate the drum assembly and front frame.



- When installing

- (10) M20X90: 539 N·m (398 lbf-ft)
(Vibrator motor side)
- (10) M20X80: 539 N·m (398 lbf-ft)
(Propulsion motor side)
- (11) M16X70: 265 N·m (195 lbf-ft)

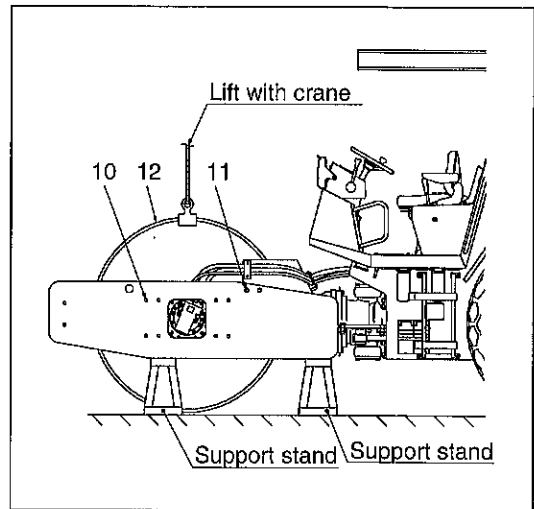

- 7) As shown in the figure on the right, use support stands or other means to firmly secure the side of the vehicle body on which the drum was removed. Ensure that the vehicle body does not move.

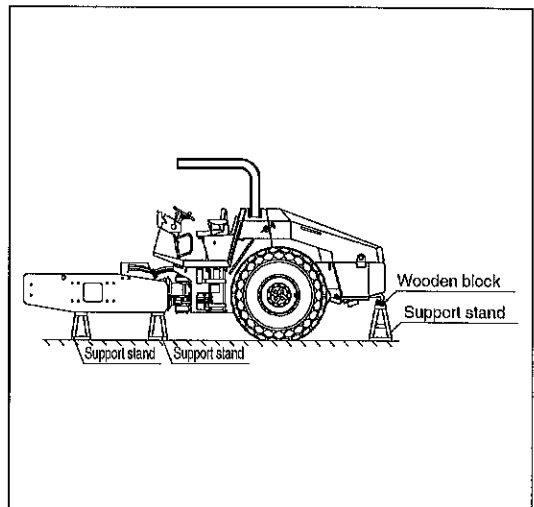

- 8) Place chock blocks at the front and rear of the removed drum assembly (12) to prevent the drum assembly from moving.

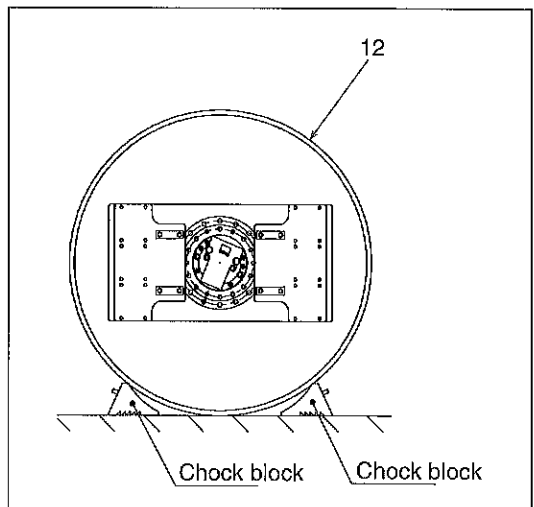

6-005

VIBRATORY DRUM

2-1-2. Installation of vibratory drum

- 1) Install the vibratory drum in the reverse order in which it was removed.
 - Tightening torque for bolts in locations requiring particular attention during reinstallation of the vibratory drum:



- (10) M20X90: 539 N·m (398 lbf·ft)
(Vibrator motor side)
- (10) M20X80: 539 N·m (398 lbf·ft)
(Propulsion motor side)
- (11) M16X70: 265 N·m (195 lbf·ft)
- (2) M20X110: 539 N·m (398 lbf·ft)

- 2) When installing the vibratory drum, pay particular attention to the items mentioned below.

CAUTION

If the engine is run at high speed or the cylinder is operated to full stroke when the engine is started for the first time after work is completed, the piston packing or other items may be damaged by air entering into the cylinder.

- ★ Fill the hydraulic oil tank to the specified level to make up for any oil leakage.
- ★ Start the engine and circulate the oil through the piping. Then check the oil level again, ensuring that the oil is at the specified level.

2-2. Vibratory drum assembly

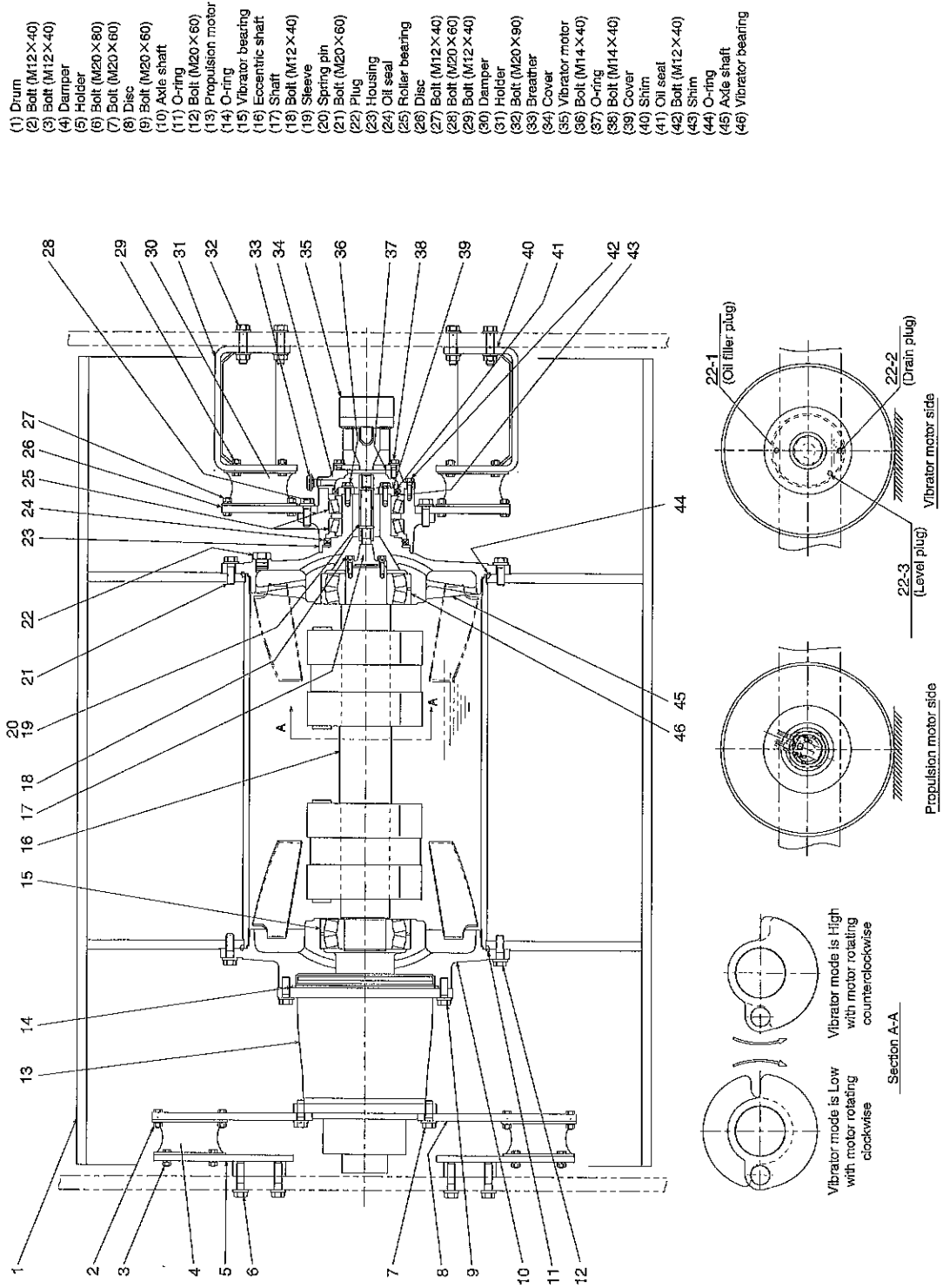



2008/08/10 16:12:43

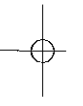
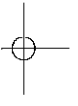

086_VIBRATION_C-F6-07_A3.indd 2

2-3. Disassembly and reassembly of vibratory drum

- Leader numbers appearing in the vibratory drum disassembly and reassembly procedure illustrations shown below correspond to the numbers indicating the parts of the vibratory drum assembly (page 6-007).

2-3-1. Disassembly of vibratory drum

- 1) Remove the plugs (22-1 and 22-2).
 - Drain the gear oil from the vibrator case.
 - Gear oil quantity: 34 L (9.0 gal.)

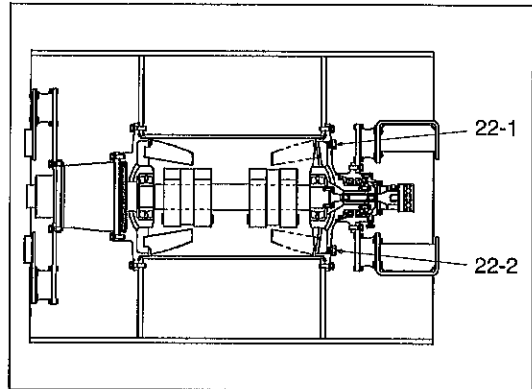

- 2) Lift the vibratory drum with a crane. As shown in the figure on the right, stand it up with the propulsion motor side facing downward.

WARNING

After standing up the drum, place wooden blocks that have sufficient strength underneath. Stabilize the drum so that it is not unsteady.

| | |
|---|--------------------------|
|  Vibratory drum assembly | |
| SV510D-II | : 4,050 kg (8,930 lbs.) |
| SV510T/D-II | : 4,350 kg (9,590 lbs.) |
| SV510TF/TFB-II | : 6,550 kg (14,440 lbs.) |

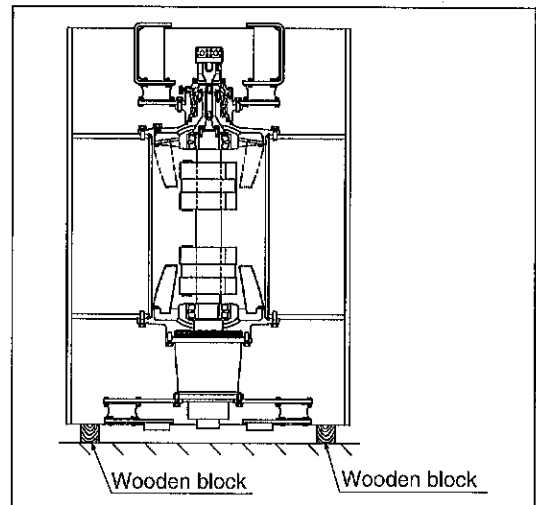

- 3) Remove the two bolts (38).
 - Remove the vibrator motor (35).
 - Remove the breather (33).

WARNING

Use aids such as work stepladders when working, and work with a natural, unstrained posture.

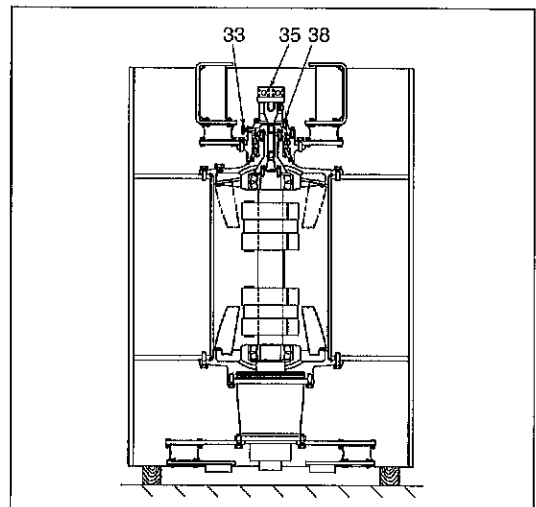

VIBRATORY DRUM

- 4) Remove the sixteen bolts (28).
- Attach the lifting bolts/nuts (M20 x 2.5) as shown in the figure on the right.
 - Using a crane, lift and remove the holder (31), damper (30) and disc (26) together.

 Total of lifted parts (31,30 and 26)
: 150 kg (330 lbs.)

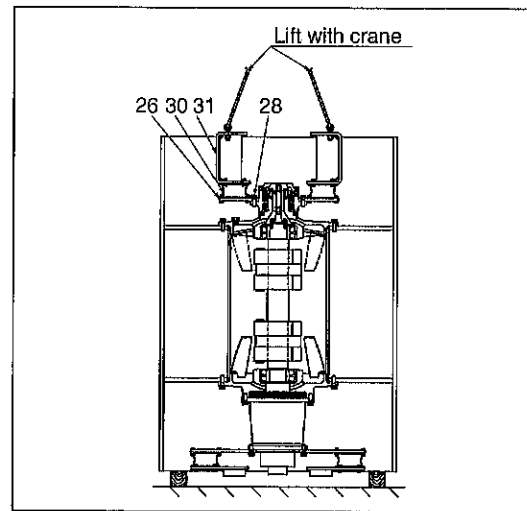

- 5) Remove the sixteen bolts (21).
- Remove the sleeve (19).

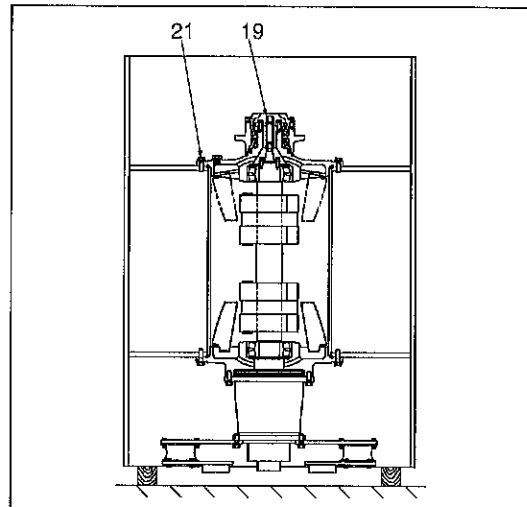

- 6) Attach the lifting bolts (M20 x 2.5) as shown in the figure on the right.
- Using a crane, slowly lift and remove the axle shaft (45).

★ At this time, to ensure that the vibrator shaft does not follow along with the axle shaft (45), lift the end of the vibrator shaft while lightly tapping with a wooden hammer through a wood block.

 Axle shaft: 220 kg (485 lbs.)

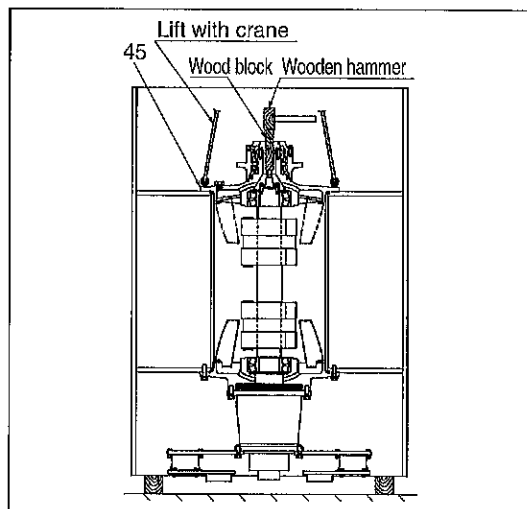

CAUTION

When attaching the lifting bolts, screw in the threads fully before using.

6-009

VIBRATORY DRUM

- 7) Attach a lifting bolt (M10 x 1.5) to the end of the vibrator shaft (16). Then lift with a crane and remove.

 Vibrator Shaft: 250 kg (550 lbs.)

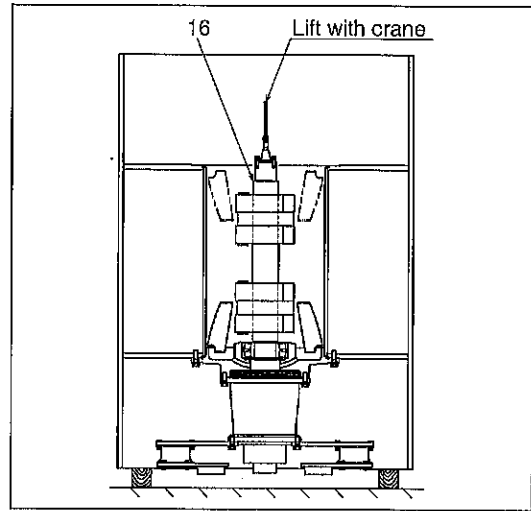

- 8) In the figure on the right, the vibrator motor side is up. From the top, the figure shows the condition with the part removed.

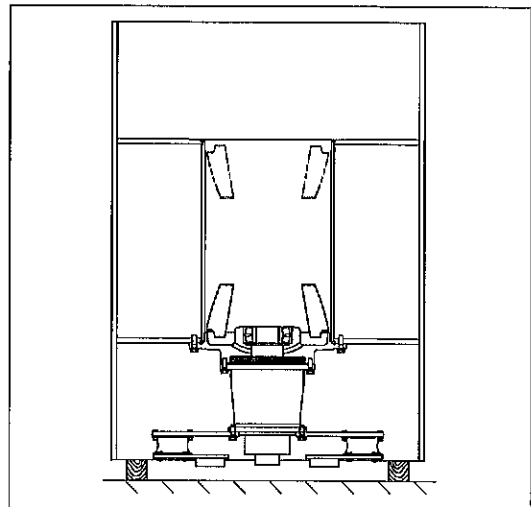

- 9) Lift and invert the drum with a crane. Stand it up with the propulsion motor side upward.

 Lifted weight in figure on the right

| | |
|----------------|--------------------------|
| SV510D-II | : 3,550 kg (7,830 lbs.) |
| SV510T/D-II | : 3,900 kg (8,600 lbs.) |
| SV510TF/TFB-II | : 6,100 kg (13,450 lbs.) |

⚠ WARNING

Inverting the drum can be dangerous work. Therefore, be very careful, confirm that the surrounding area is safe and work in a natural, unstrained posture.

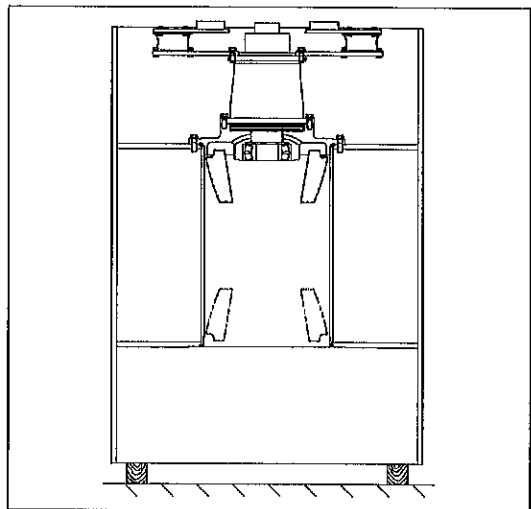

VIBRATORY DRUM

10) Remove the sixteen bolts (7).

- As shown in the figure on the right, attach the lifting bolt (M20 x 2.5) to the holder (5) and slowly lift. Remove together with the damper (4) and disc (8).

 Total of lifted parts (5,4 and 8)
: 150 kg (330 lbs.)

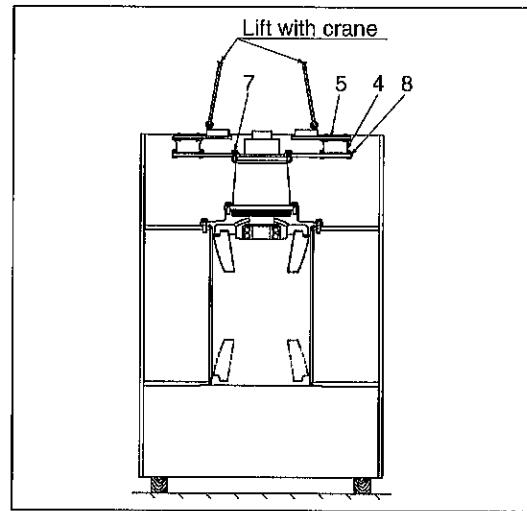

11) Remove the sixteen bolts (9).

- Remove the propulsion motor (13).

 Propulsion motor: 220 kg (485 lbs.)

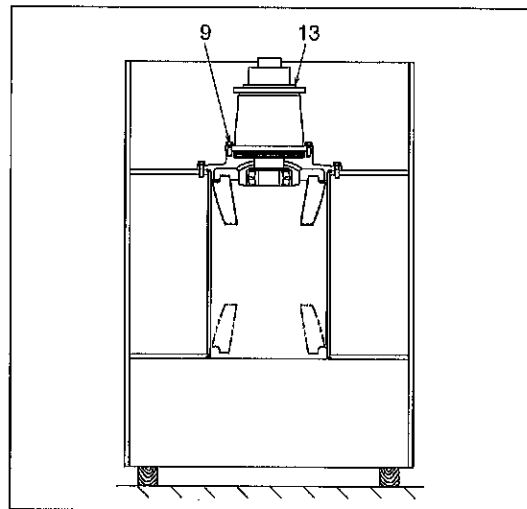

12) Remove the sixteen bolts (12).

- Remove the axle shaft (10).

 Axle shaft: 180 kg (395 lbs.)

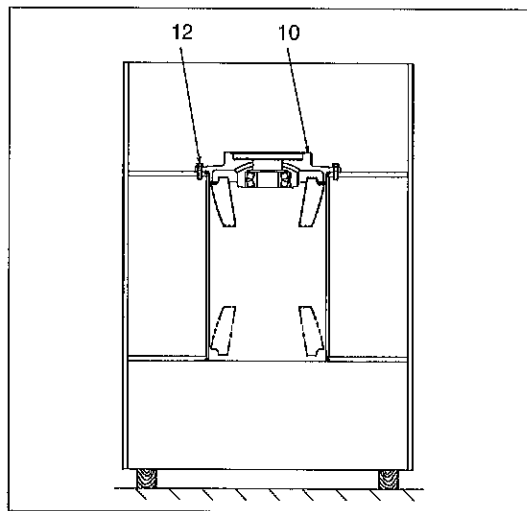

VIBRATORY DRUM

- 13) The figure on the right shows the condition in which all parts have been removed from the vibratory drum assembly.

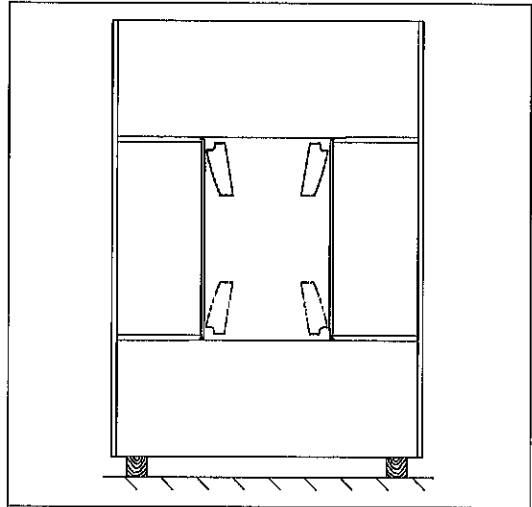

- 14) The figure on the right shows the axle shaft subassembly removed from the vibratory drum.
- Remove the six bolts (42).
 - Remove the cover (34).

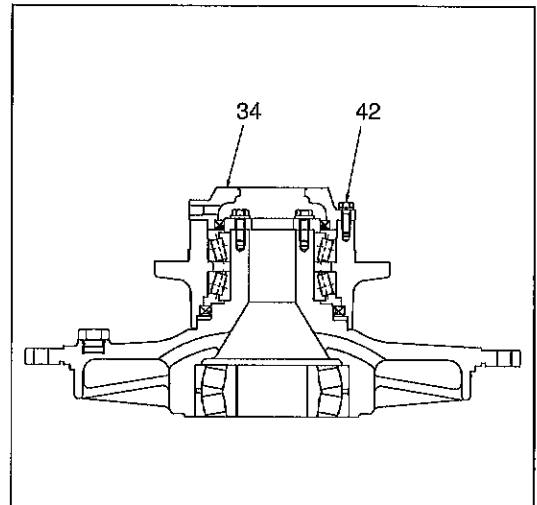

- 15) Remove the eight bolts (36).
- Remove the cover (39).

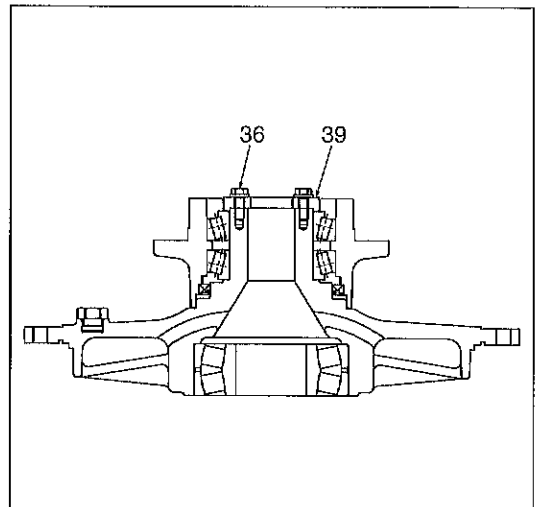

VIBRATORY DRUM

- 16) Place the plate at the end of the axle shaft. With the puller against the housing (23), separate the housing, including the roller bearing, from the axle shaft.

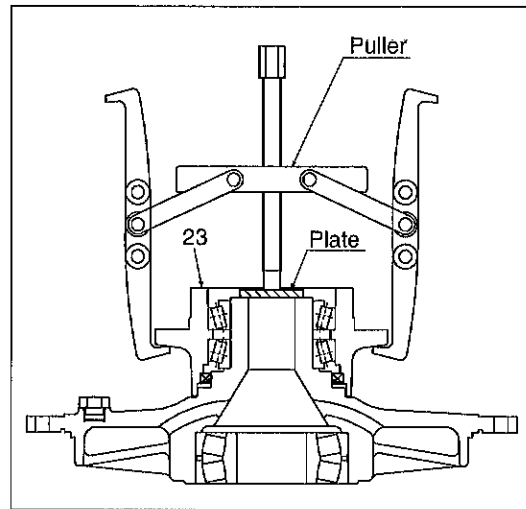

2-3-2. Reassembly of vibratory drum

★ Before reassembling, confirm that each part that was disassembled has been well cleaned and is free of any abnormality.

- 1) Lightly apply gear oil to the press-fitting surface of the drum bearing (25) outer race.
 - Drive the outer race of the drum bearing (25) into the housing (23).
 - Attach the oil seal (24).

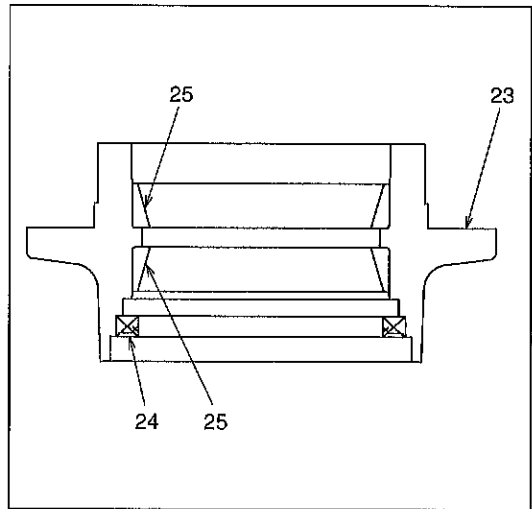

- 2) As shown in the figure on the right, firmly secure the axle shaft (45) with support stands and/or wooden blocks.
 - Lightly apply gear oil to the press-fitting surface of the vibrator bearing (46).
 - Drive in the vibrator bearing (46).

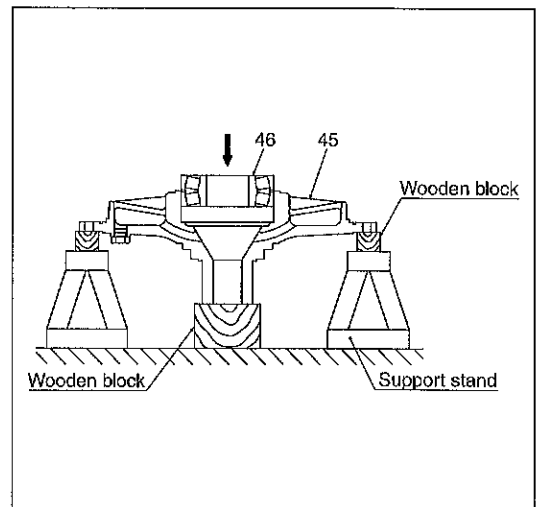

- 3) Using a crane, lift and invert the axle shaft (45) subassembly.
 - Lightly apply gear oil to the press-fitting surface of the drum bearing.
 - Attach the inner race of the drum bearing (25).

 Axle shaft subassembly: 165 kg (365 lbs.)

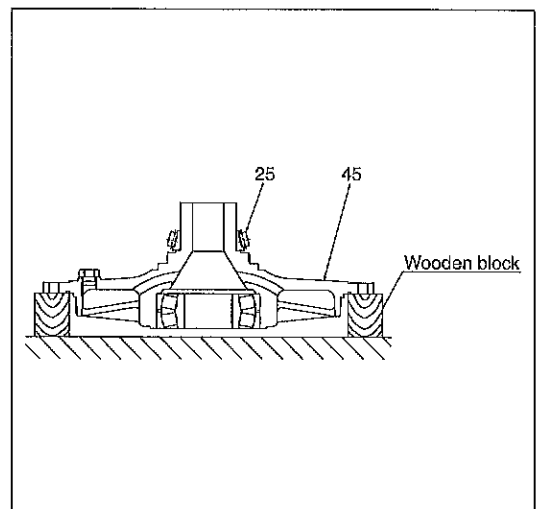

VIBRATORY DRUM

- 4) Apply an ample amount of lithium-based grease to the rolling surfaces of the roller bearing (25).
 - Lightly apply the same grease to the lip surfaces of the oil seal (24).
 - Join the axle shaft (45) subassembly and housing (23).

 Housing: 35 kg (77 lbs.)

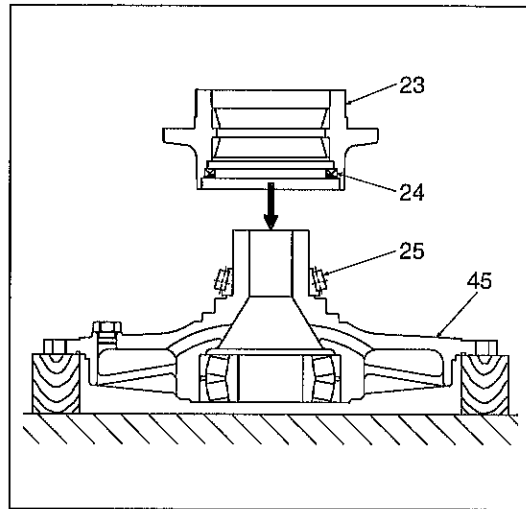

- 5) After applying an ample amount of lithium-based grease to the inner race of the roller bearing (25), drive it in until the inner race's rolling surface makes contact with the outer race.

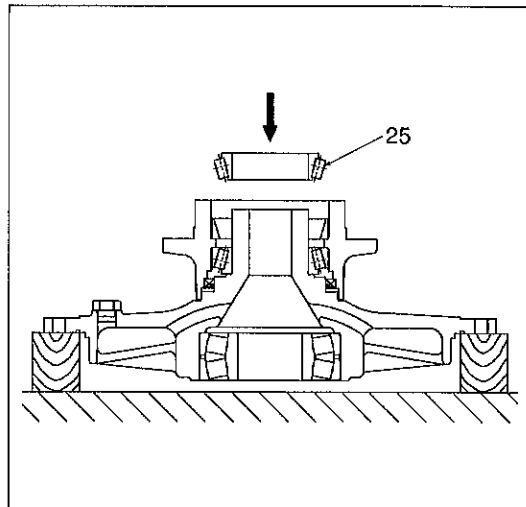

- 6) As shown in the figure on the right, insert shims (43) approximately 1 mm to create a gap between the axle shaft end face and cover (39) interior surface. Then install the cover (39).
 - Install washers to the four bolts (36), and tighten to a tightening torque of 108 N·m (80 lbf·ft).
 - Rotate the housing (23) two or three times. Then tighten the same bolts again to a tightening torque of 108 N·m (80 lbf·ft).
 - Repeat this procedure two or three times until the bolt tightening torque no longer varies.

★ When tightening the bolts (36), alternately tighten by using four of the eight bolts positioned diagonally from each other.

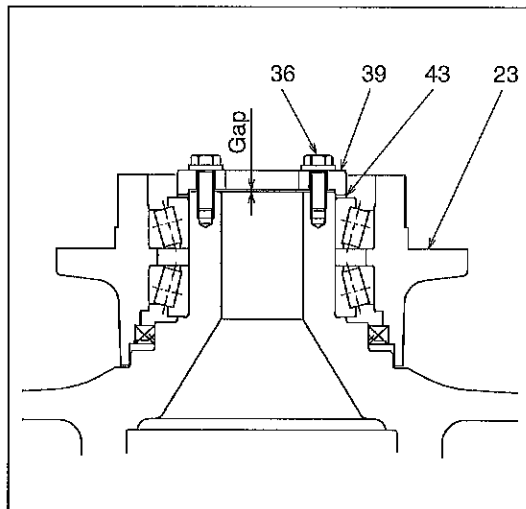

7) Roller bearing preload adjustment

- ① Remove the four bolts (36).
 - Remove the cover (39) and shim (43).

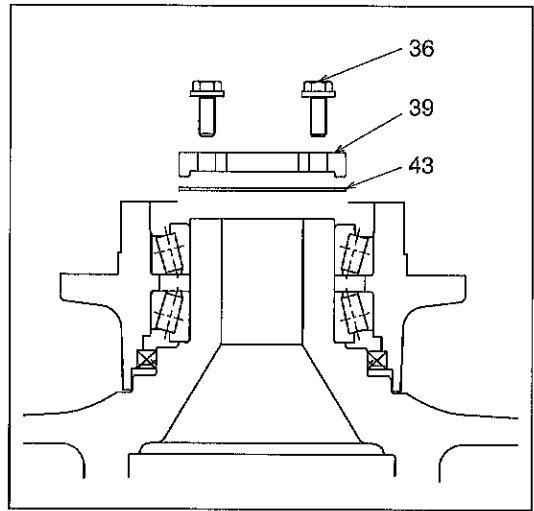

- ② Without inserting shims, install the cover (39). Then install washers to the four bolts (36) and tighten.
 - Using a thickness gauge, measure the gap at dimension A.

★ Preload adjustment shim thickness = $(A+0.1)$ mm

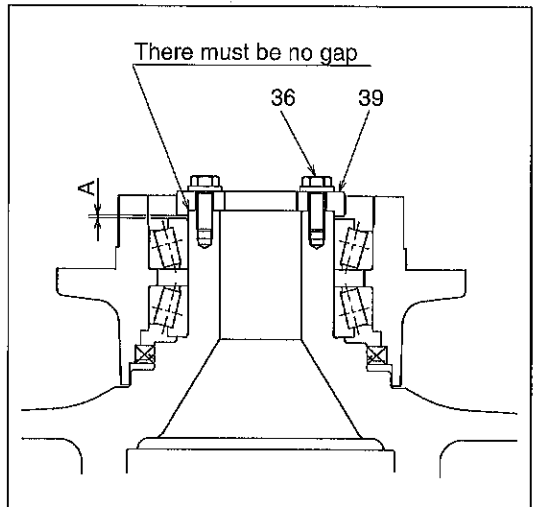

- ③ Remove the bolts (36).
 - Remove the cover (39).
 - Insert a preload adjustment shim thickness equal to $(A+0.1)$ mm. Then firmly secure the cover (39) again by installing washers to the eight bolts (36).

 (36) M14X40: 167 N·m (123 lbf·ft)

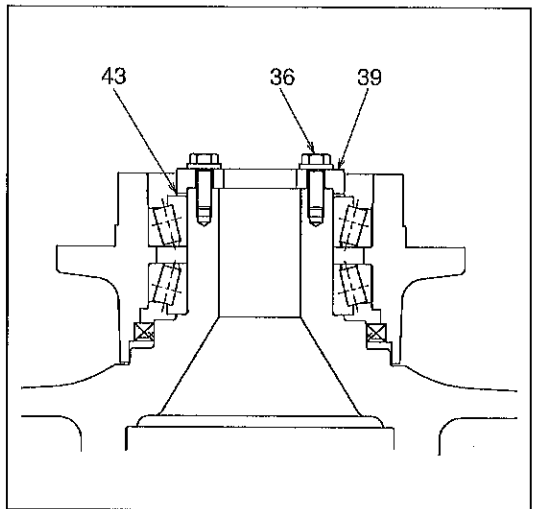



VIBRATORY DRUM

- 8) Install the oil seal (41) to the cover (34).
- Lightly apply grease to the lip surfaces of the oil seal (41).
 - Using the six bolts (42) and spring washers, firmly secure the cover (34) to the housing.

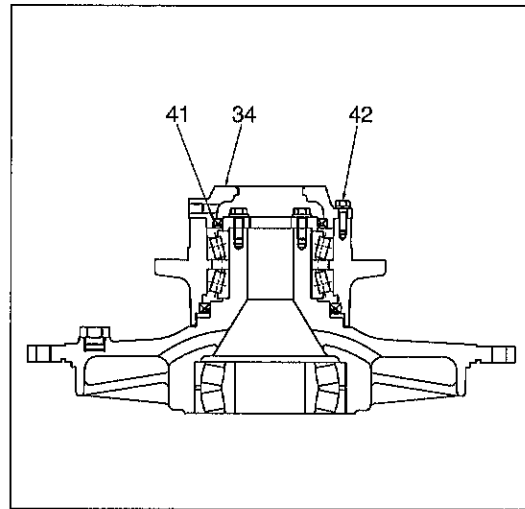
 N·m (42) M12X40: 108 N·m (80 lbf·ft)



- 9) Lightly apply gear oil to the press-fitting surface of the vibrator bearing (15).
- Drive the vibrator bearing (15) into the axle shaft (10).

 Axle shaft : 160 kg (352 lbs.)
 Vibrator bearing : 18 kg (40 lbs.)

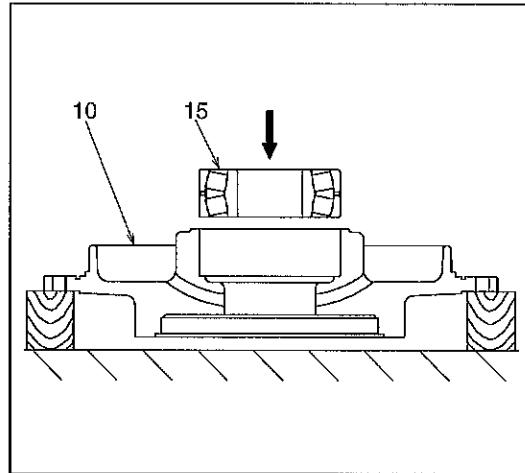

- 10) Install the O-ring (11) to the axle shaft (10).
- Lightly apply grease to the entire circumference of the O-ring (11).
 - Using the sixteen bolts (12) and washers, firmly secure the axle shaft (10) to the drum.

 N·m (12) M20X60: 539 N·m (398 lbf·ft)

(NOTE) : When installing, make sure that the O-ring does not protrude from the groove.

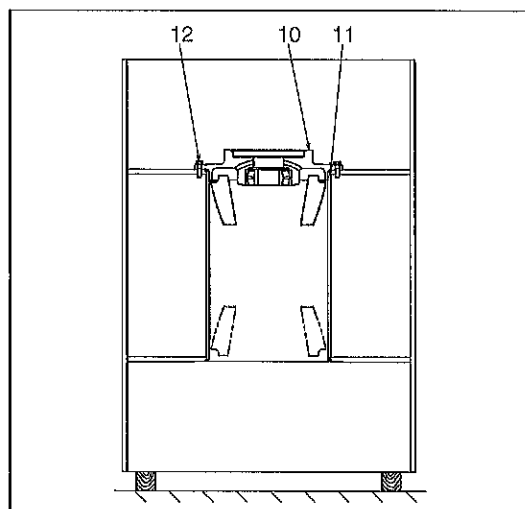

⚠ WARNING

Use aids such as work stepladders when working, and work with a natural, unstrained posture.

6-017

VIBRATORY DRUM

- 11) Attach the O-ring (14) to the propulsion motor (13).
 - Lightly apply grease to the entire circumference of the O-ring (14).
 - Using the sixteen bolts (9) and washers, firmly secure the propulsion motor (13) to the axle shaft.

NOTE: When attaching, make sure that the O-ring does not protrude from the groove.

 (9) M20X60: 539 N·m (398 lbf·ft)

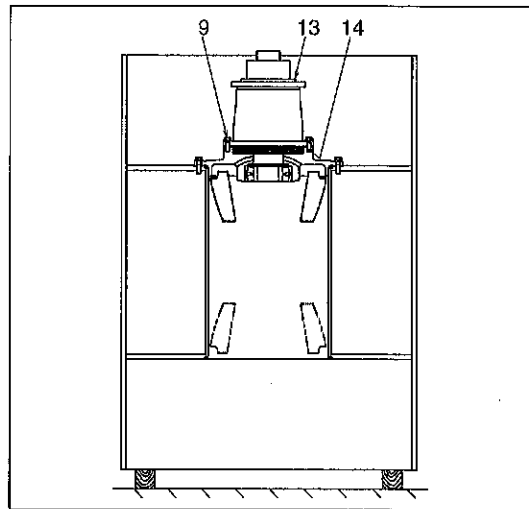

- 12) Using the sixteen bolts (7) and washers, firmly secure the subassembly of the holder (5), damper (4) and disc (8) to the propulsion motor.

 (7) M20X60: 539 N·m (398 lbf·ft)

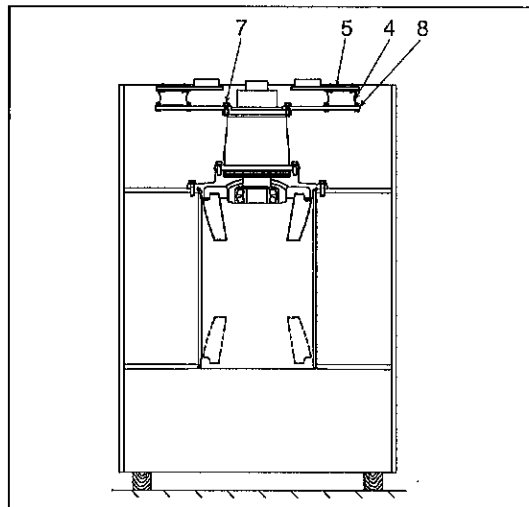

- 13) Lifting with a crane, invert the drum as shown in the figure on the right.

WARNING

Inverting the drum can be dangerous work. Therefore, be very careful, confirm that the surrounding area is safe and work in a natural, unstrained posture.

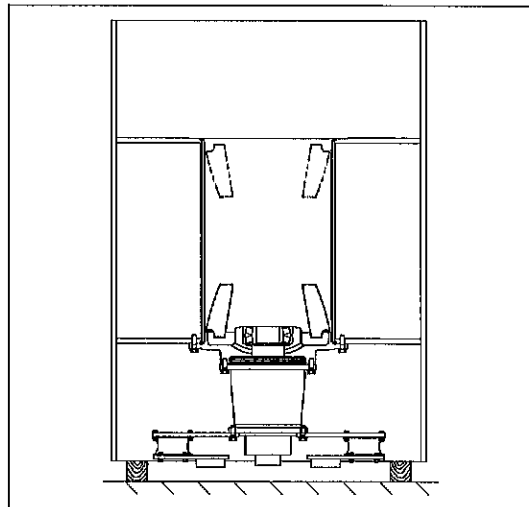

6-018

VIBRATORY DRUM

- 14) Attach a lifting bolt (M10 x 1.5) to the end of the vibrator shaft (16). Then lift with a crane, slowly lower and attach.

★ When inserting the vibrator shaft into the vibrator bearing for attachment, be careful not to allow the inner race of the vibrator bearing to lean.

 Vibrator Shaft: 250 kg (550 lbs.)

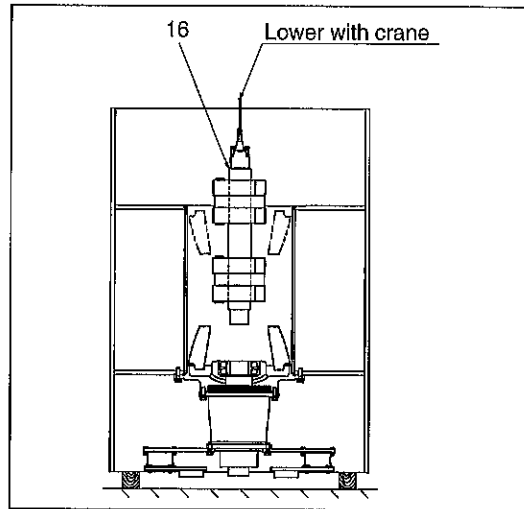

- 15) Attach the O-ring (44) to the axle shaft (45) subassembly.
- Lightly apply grease to the entire circumference of the O-ring (44).
 - Lift and slowly lower the axle shaft (45) subassembly with a crane.

★ When attaching the axle shaft, move the vibrator shaft until the center of the vibrator bearing inner race is aligned with the center of the shaft. Be careful not to allow the vibrator bearing to lean.

 Axle shaft (45) subassembly: 250 kg (550 lbs.)

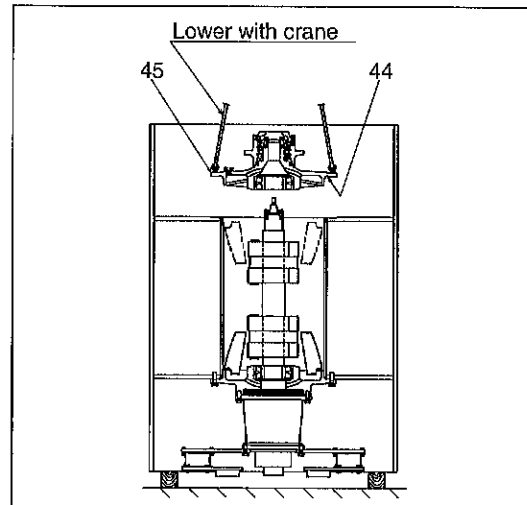

- 16) Using the sixteen bolts (21) and washers, firmly secure the axle shaft subassembly to the drum.

NOTE: When attaching, make sure that the O-ring does not protrude from the groove.

 (21) M20X60: 539 N·m (398 lbf·ft)

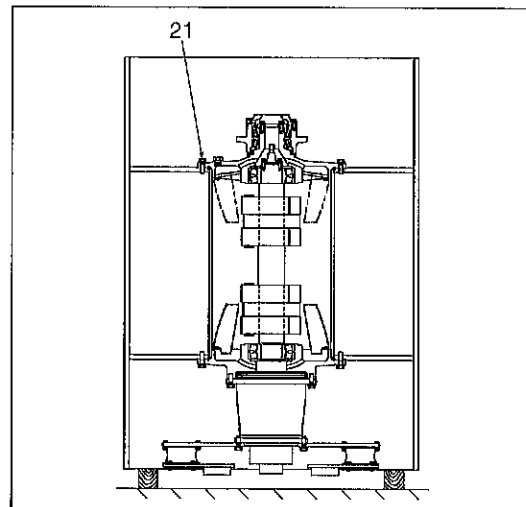

VIBRATORY DRUM

- 17) Attach a lifting bolt (M10 x 1.5) to the vibrator shaft end. Then slowly lift with a crane. Confirm that 1 ~ 3 mm (0.04 ~ 0.12 in.) of play exists in the axial direction.

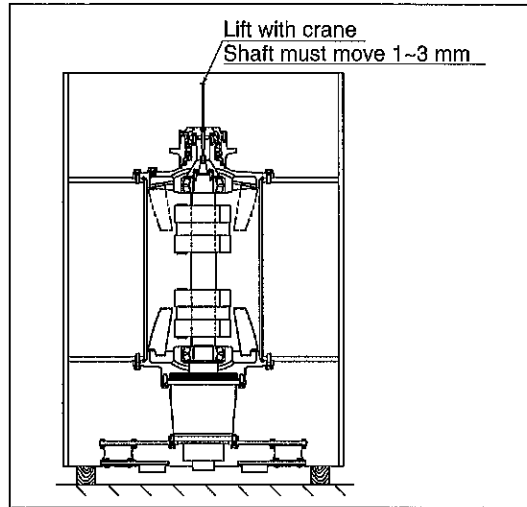

- 18) Using a crane, lift and slowly lower the subassembly of the holder (31), damper (30) and disc (26).

 Total of lifted parts (31, 30 and 26)
: 150 kg (330 lbs.)

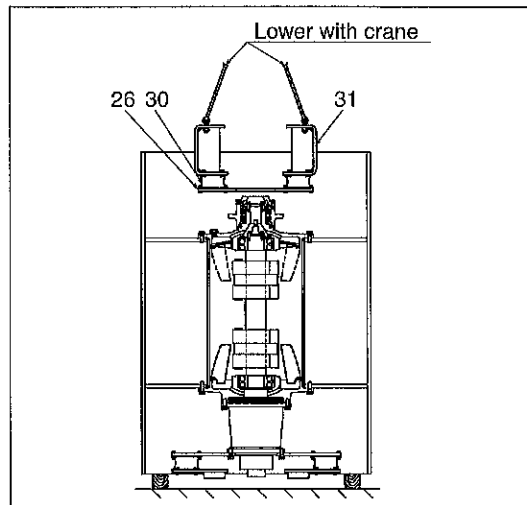

- 19) Using the sixteen bolts (28) and washers, firmly secure the holder subassembly to the housing.
 • Apply a molybdenum-based grease to the spline surface of the sleeve (19), and attach it to the spline shaft at the end of the vibrator shaft.

 (28) M20X60: 539 N·m (398 lbf·ft)

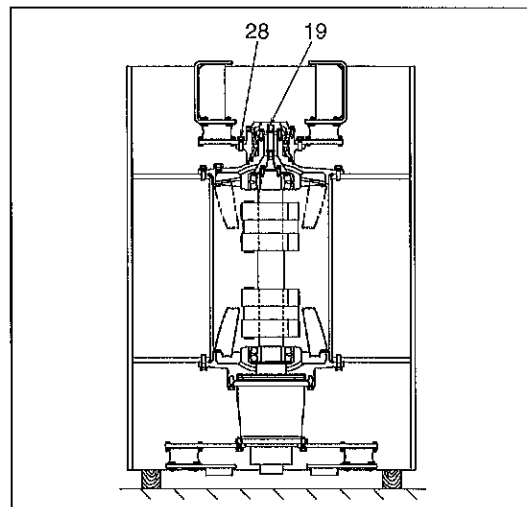

VIBRATORY DRUM

20) Attach the breather (33).

- Attach the O-ring (37) to the vibrator motor (35). Using the two bolts (38) and washers, firmly secure it to the cover.

★ Attach by aligning the top side of the vibrator motor (35) and breather (33) with the top side of the propulsion motor.

 (38) M14X40: 167 N·m (123 lbf·ft)

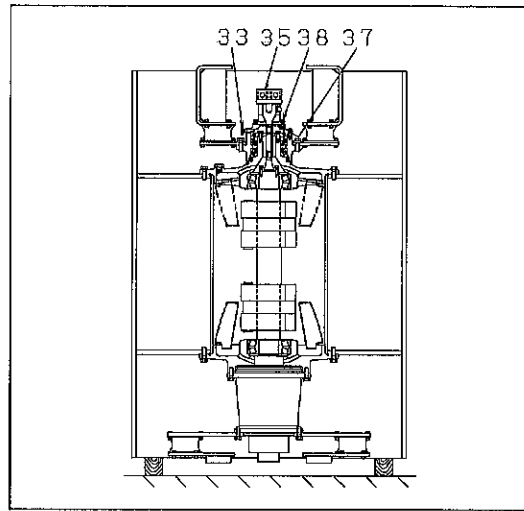

21) Lift the vibratory drum assembly with a crane, and set it sideways at the position of the plug shown in the figure on the right.

- Remove the oil filler plug and level plug.
- From the oil filler plug hole, add approximately 34 L (9.0 gal.) of gear oil until gear oil drips from the level plug hole.
- Attach the oil filler plug and level plug.

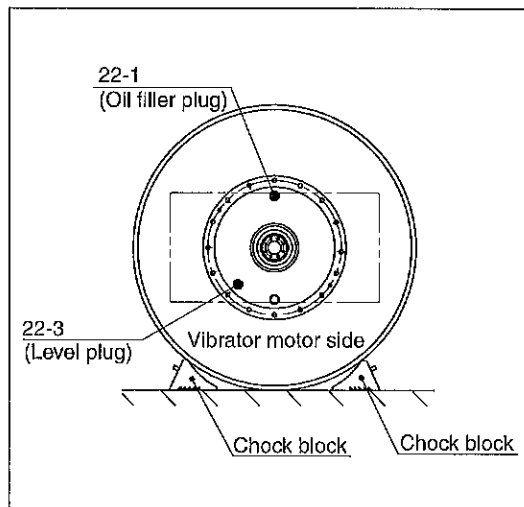

3. AXLE

3-1. Rear axle

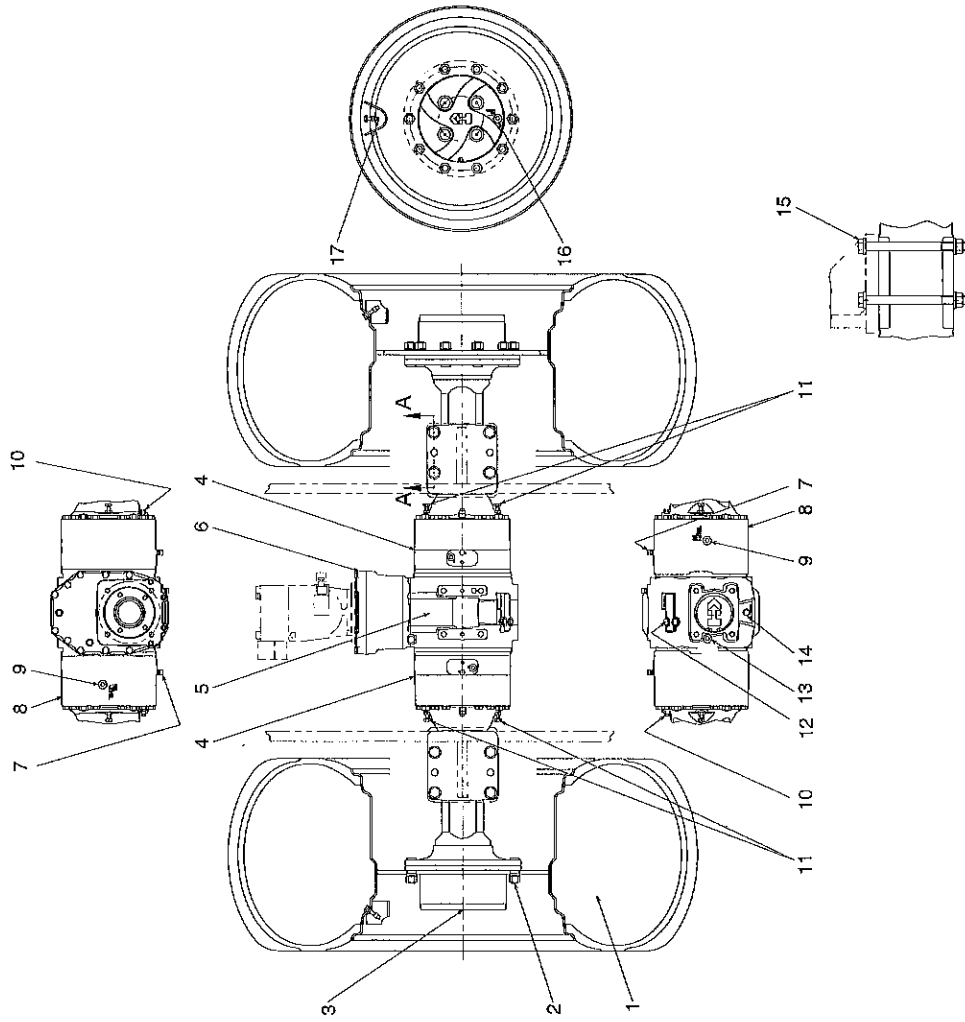

(1) Tire (Tire inflation pressure: 137.5 kPa (20 psi))
 (2) Nut (M22 p=1.5)

 785 N·m (579 lbf·ft)

- (3) Hub reduction gear
- (4) Brake
- (5) Differential
- (6) Gearbox
- (7) Plug (for brake component lubrication)
- (8) Plug (for brake component drain)
- (9) Plug (for brake component lubrication and level gauge)
- (10) Bolt (for brake adjustment)
- (11) Bolt (for brake release)
- (12) Plug (for differential component lubrication)
- (13) Plug (for differential component lubrication and level gauge)
- (14) Plug (for differential component drain)
- (15) Bolt (M120 x 250)

 539 N·m (398 lbf·ft)

- (16) Plug (for hub reduction gear component lubrication, level gauge and drain)
- (17) Valve

- Rear axle assembly weight: 1000 kg (2200 lbs.)
- Tire assembly weight: 210 kg (465 lbs.)

Section A-A



2009/06/10 15:59:19



USER_VIBRATION_~PS-02Z_A3.indd 2

3-2. Rear axle lubrication

- Lubricating oil : Gear oil API-GL4 grade SAE90 (See recommended lubrication.)
- Lubricating oil quantity

| | |
|------------------------------|-------------------------------|
| Gearbox component | : 2.0 L (0.53 gal.) |
| Center housing component | : 9.5 L (2.51 gai.) |
| Hub reduction gear component | : 1.75 L X 2 (0.46 gal. X 2) |

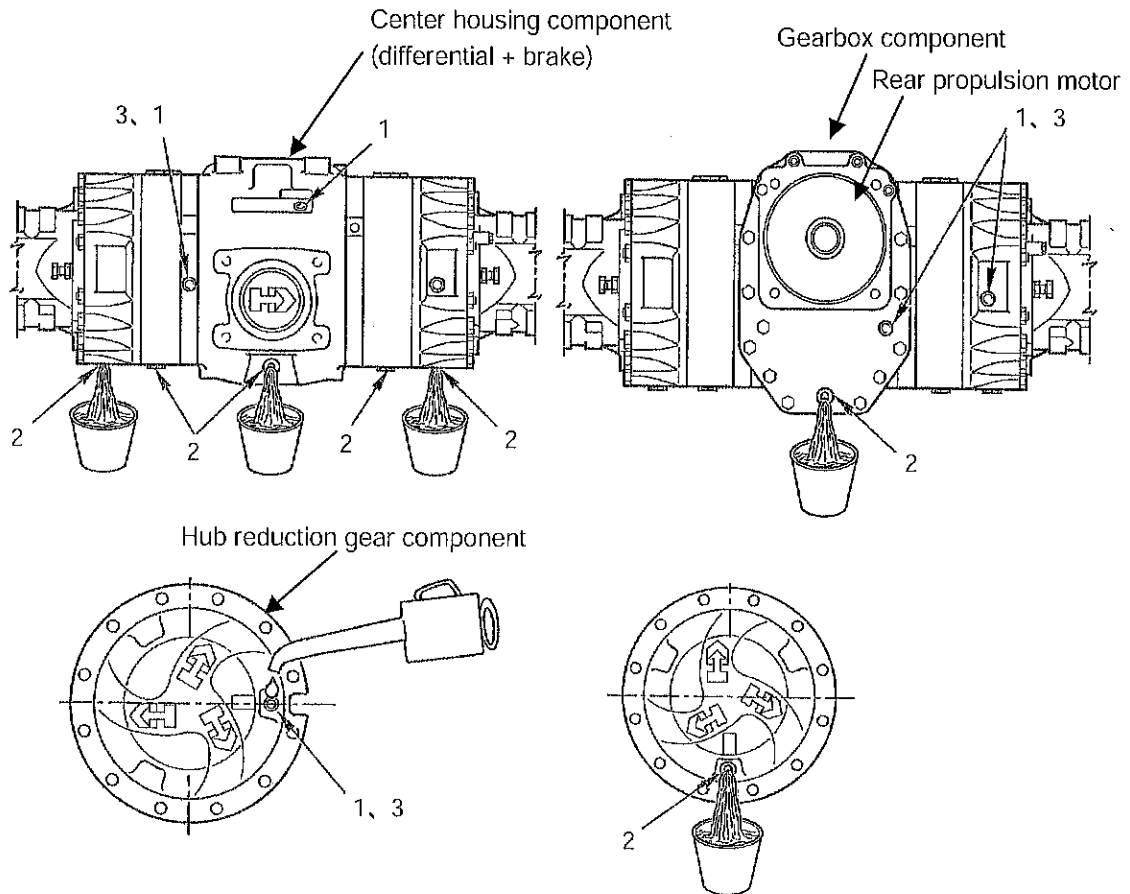

- (1) Filler port plug
- (2) Drain plug
- (3) Level gauge plug

3-3. Rear axle structure

3-3-1. Gearbox

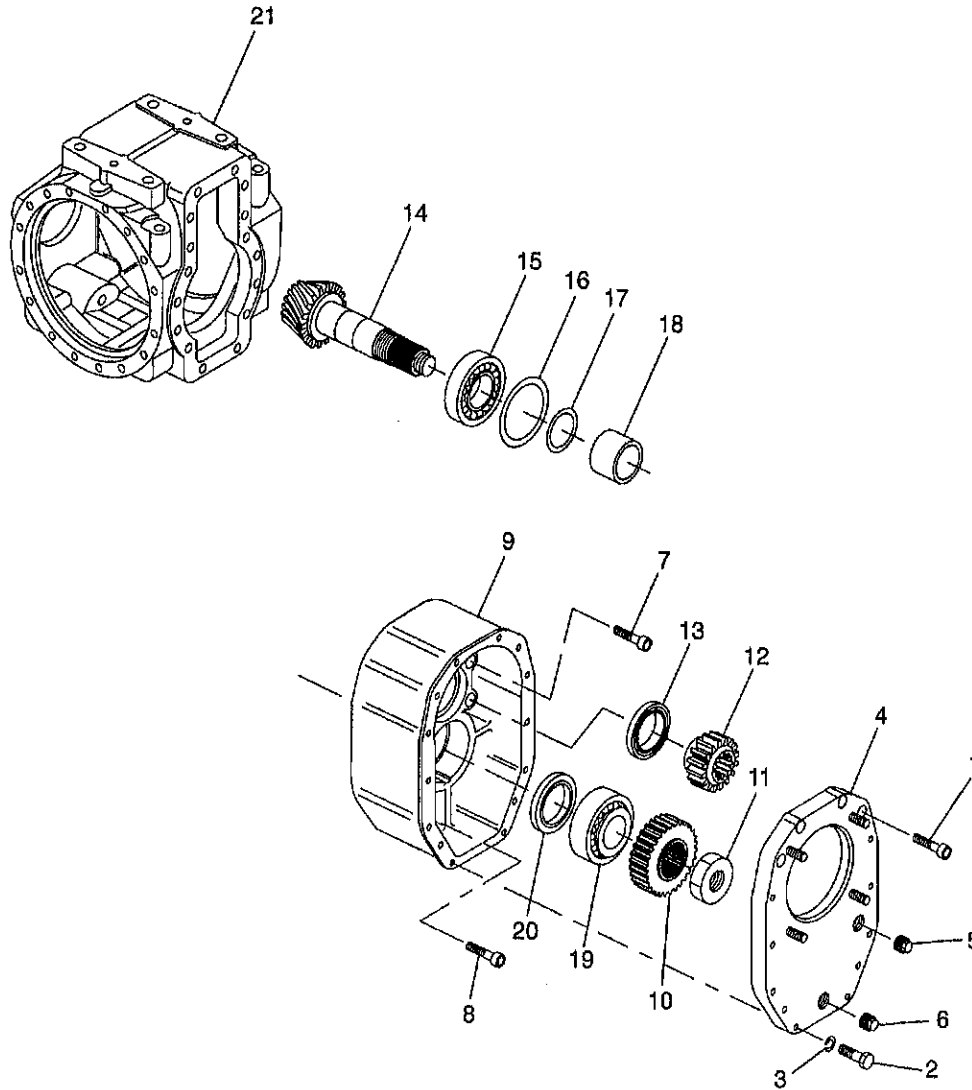

- | | | |
|------------|-------------------------|--------------|
| (1) Bolt | (8) Bolt | (15) Bearing |
| (2) Bolt | (9) Housing | (16) Shim |
| (3) Washer | (10) Gear | (17) Shim |
| (4) Cover | (11) Nut | (18) Spacer |
| (5) Plug | (12) Gear | (19) Bearing |
| (6) Plug | (13) Seal | (20) Seal |
| (7) Bolt | (14) Bevel pinion shaft | (21) Housing |

3-3-2. Center housing

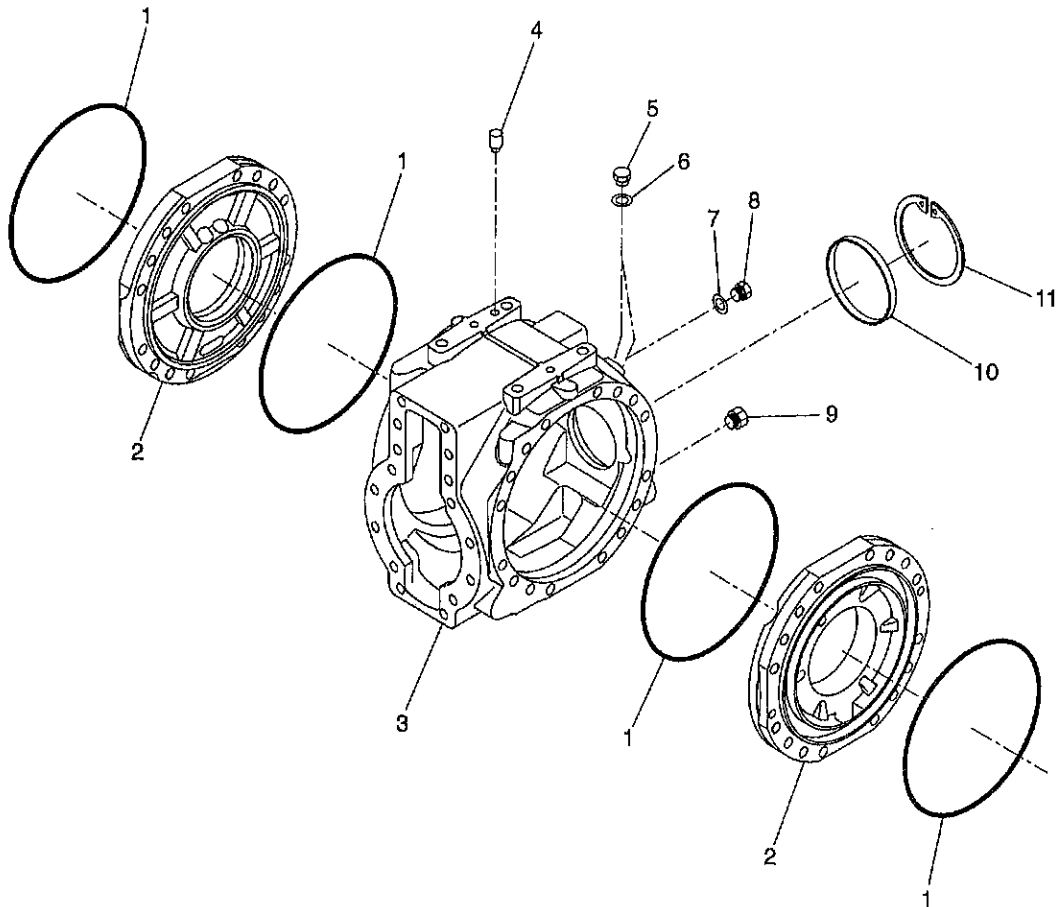

- (1) O-ring
- (2) Cover
- (3) Housing
- (4) Vent

- (5) Bolt
- (6) Seal washer
- (7) Seal washer
- (8) Plug

- (9) Magnet plug
- (10) Ring
- (11) Snap ring

3-3-3. Differential

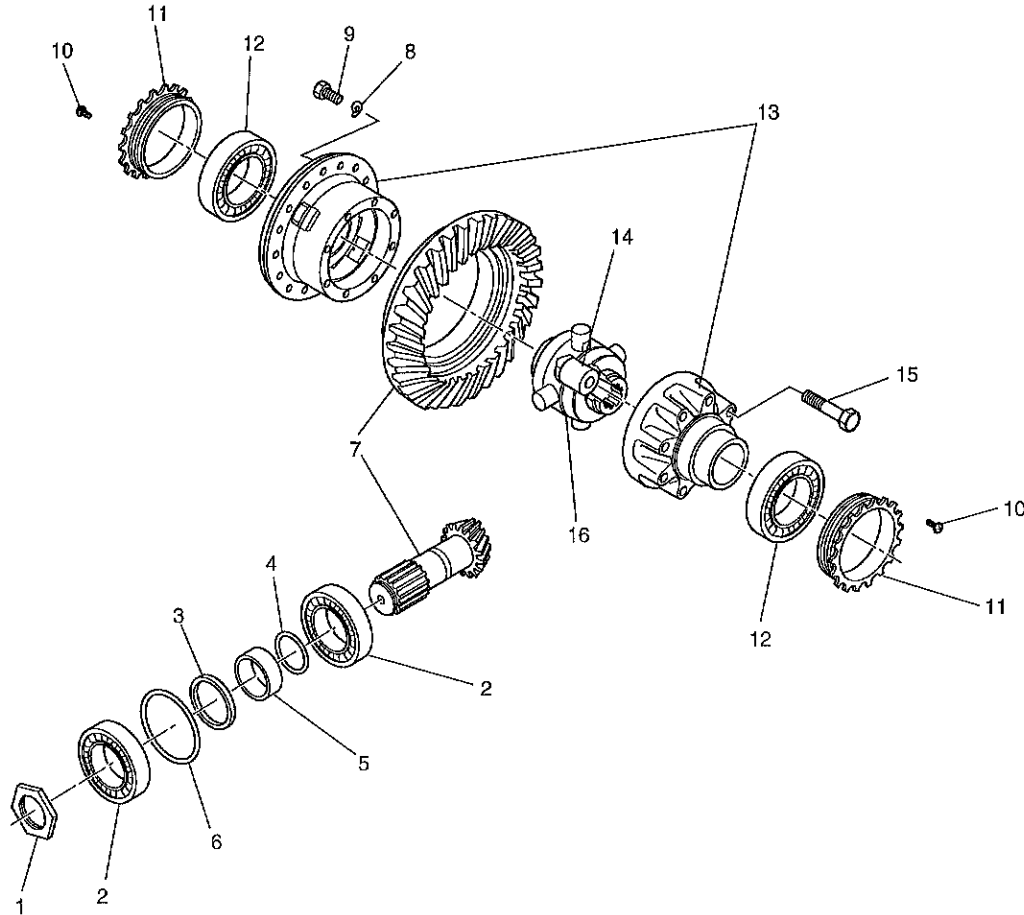

- | | | |
|----------------------------|-----------------------------|---------------------------|
| (1) Ring nut | (7) Bevel gear set | (13) Differential carrier |
| (2) Tapered roller bearing | (8) Spring washer | (14) Spacer |
| (3) Seal | (9) Bolt | (15) Bolt |
| (4) Shim | (10) Cylinder bolt | (16) No spin differential |
| (5) Spacer | (11) Ring nut | |
| (6) Shim | (12) Tapered roller bearing | |

3-3-4. Hub reduction gear

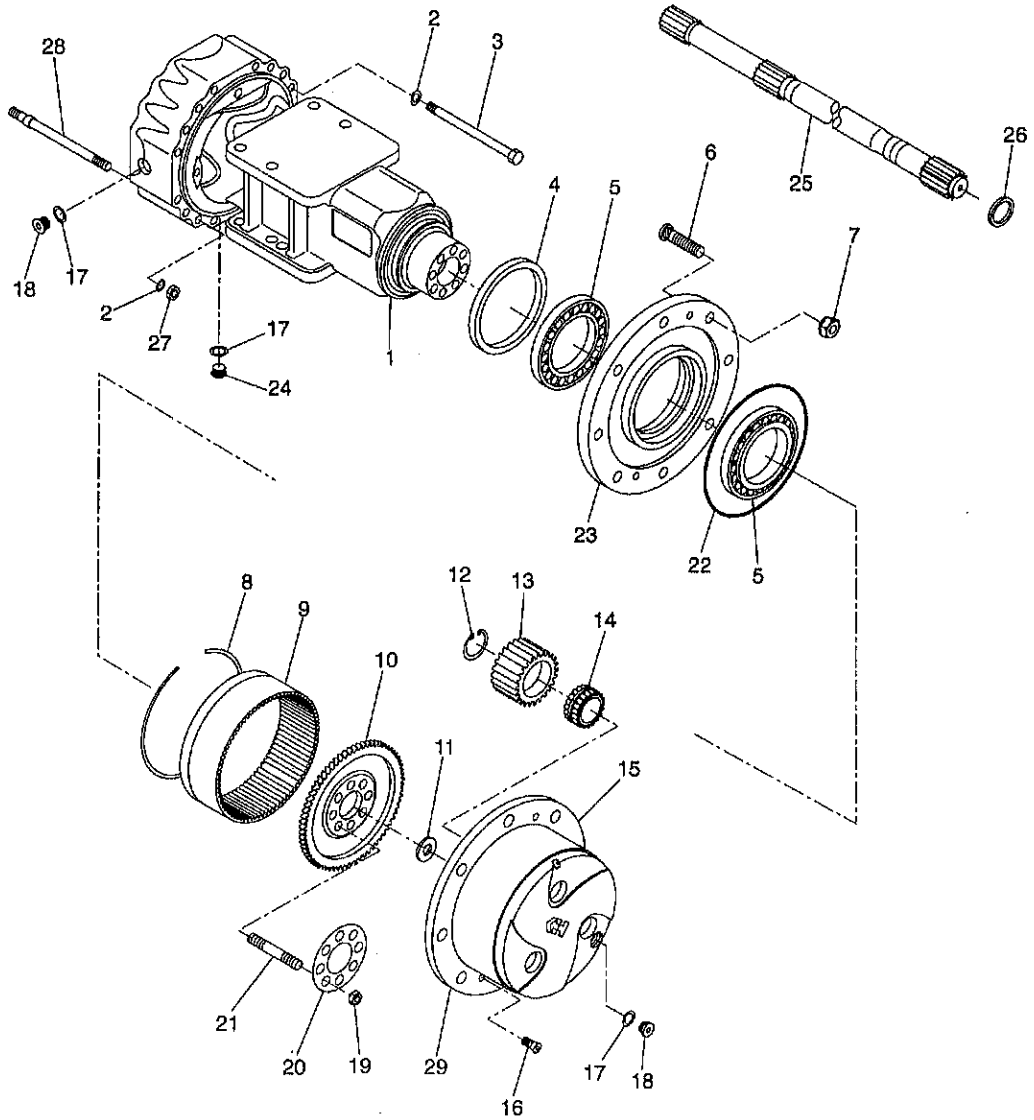

- | | | |
|------------------------|-----------------------------|-----------------------------|
| (1) Axle case | (11) Friction washer | (21) Stud bolt |
| (2) Spring washer | (12) Ring | (22) O-ring |
| (3) Bolt | (13) Planetary gear | (23) Wheel hub |
| (4) Seal | (14) Bearing | (24) Magnet plug |
| (5) Bearing | (15) Planetary gear carrier | (25) Axle shaft |
| (6) Hub bolt | (16) Counter | (26) Seal |
| (7) Hub nut | (17) Seal washer | (27) Nut |
| (8) C-clip | (18) Plug | (28) Stud bolt |
| (9) Ring gear | (19) Nut | (29) Planetary gear carrier |
| (10) Ring gear support | (20) Lock plate | |

3-3-5. Brake

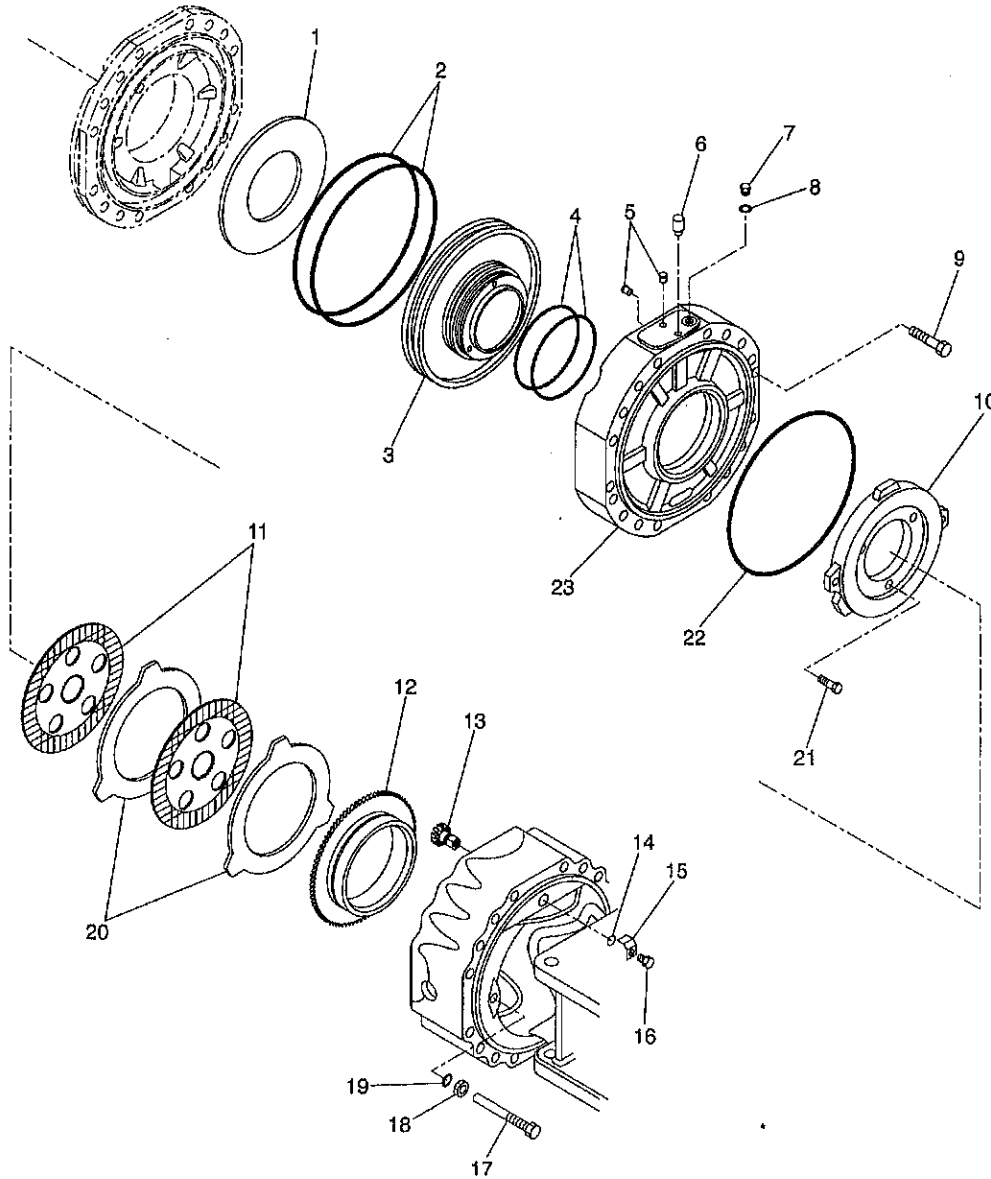

- (1) Spring
- (2) O-ring
- (3) Piston
- (4) O-ring
- (5) Bolt
- (6) Vent
- (7) Bolt
- (8) Seal washer

- (9) Bolt
- (10) Disc
- (11) Friction plate
- (12) Ring
- (13) Pinion
- (14) O-ring
- (15) Lock plate
- (16) Hexagon bolt

- (17) Bolt
- (18) Nut
- (19) Lock washer
- (20) Separating plate
- (21) Cylinder bolt
- (22) O-ring
- (23) Cover



BRAKES



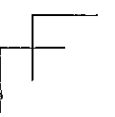
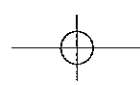
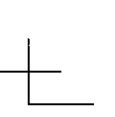
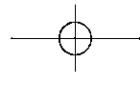
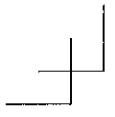

1. BRAKE SYSTEM

1-1. Brake pedal

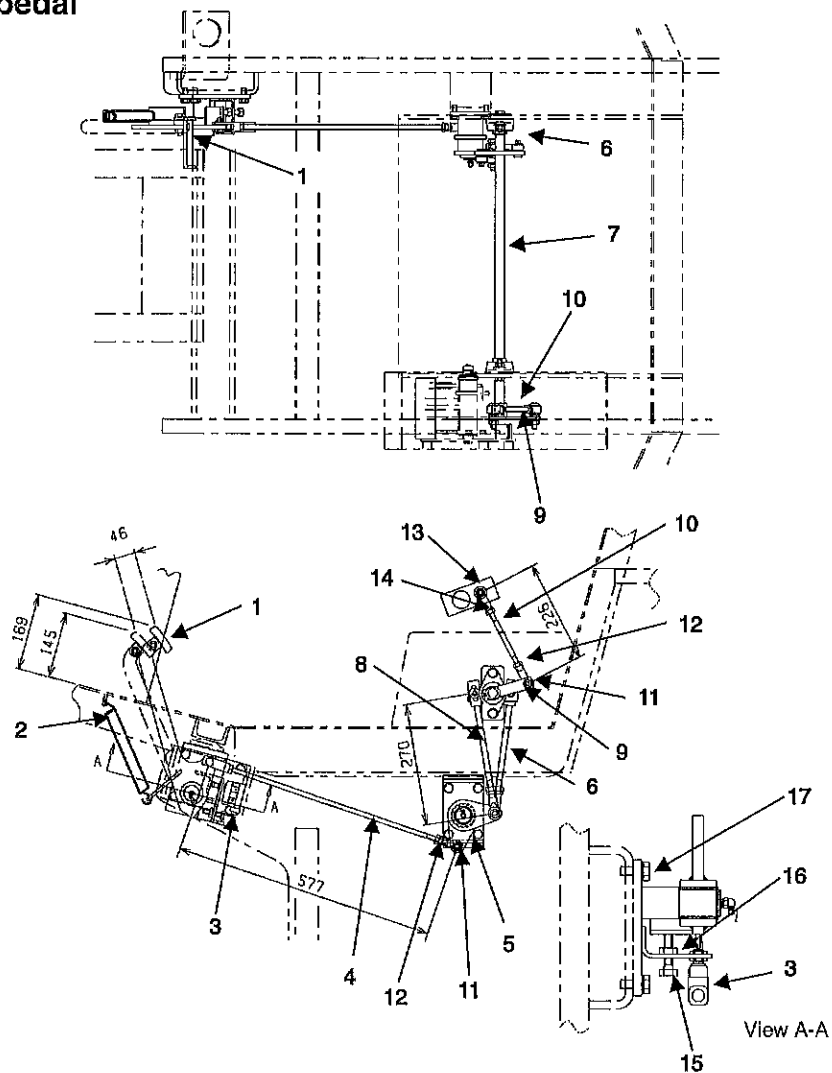

- | | | |
|-----------------------|-----------------------------------|------------------------------------|
| (1) Brake pedal | (7) Shaft | (13) Ball joint (right-hand screw) |
| (2) Return spring | (8) Rod | (14) Nut (right-hand screw) |
| (3) Foot brake switch | (10) Rod | (15) Bolt (M10×40) |
| (4) Rod | (11) Ball joint (left-hand screw) | (16) Nut (M10) |
| (5) Arm | (12) Nut (left-hand screw) | (17) Bolt (M10×25) |
| (6) Shaft | | |

 49 N·m (36 lbf·ft)

• Since No. 11 and 12 are left-hand screws, note the direction of installation for No. 4 and 10.

1-2. Brake circuit configuration

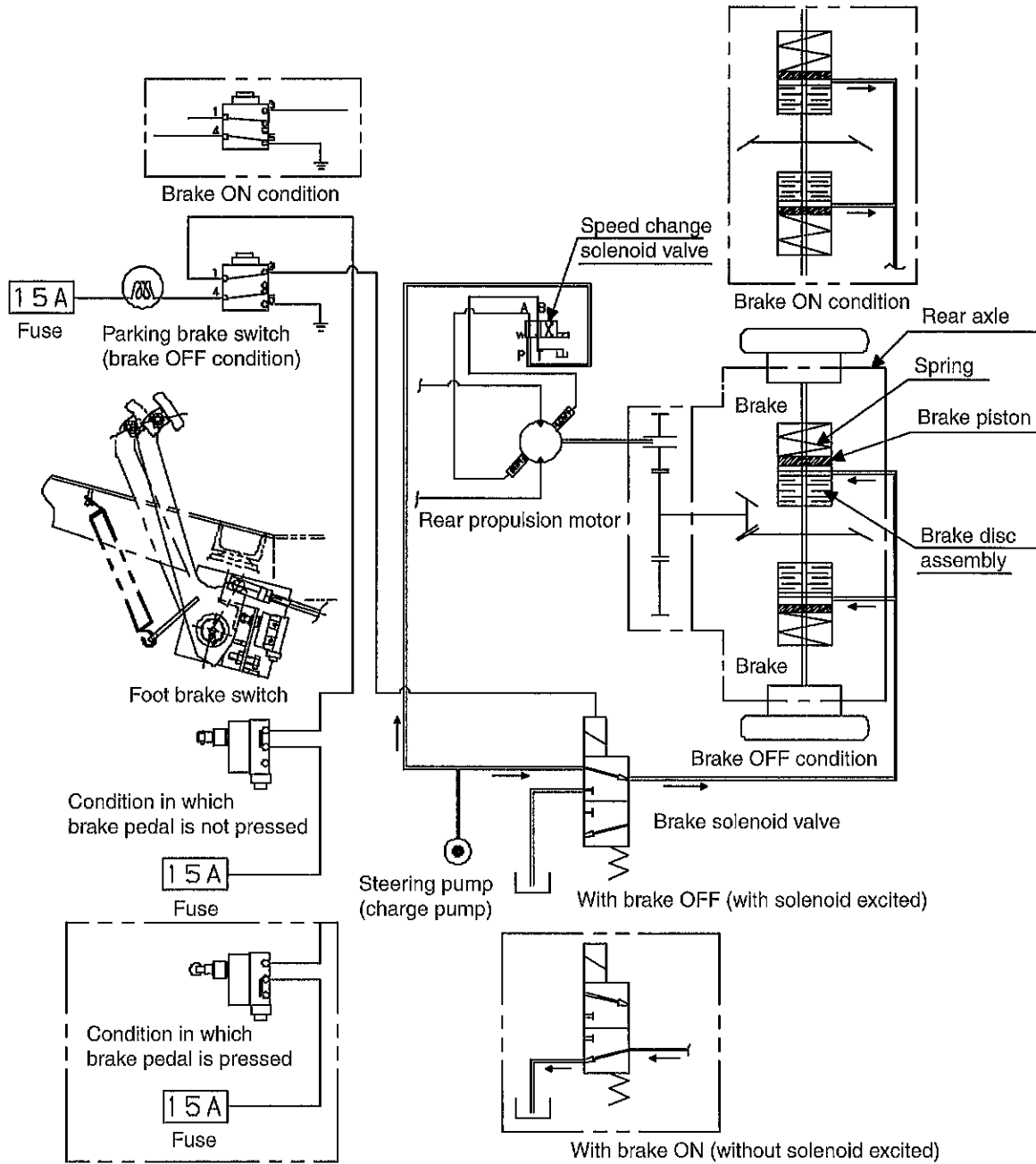

· The arrow (→) symbol shows the direction of flow of the hydraulic oil.

1-3. Brake piping

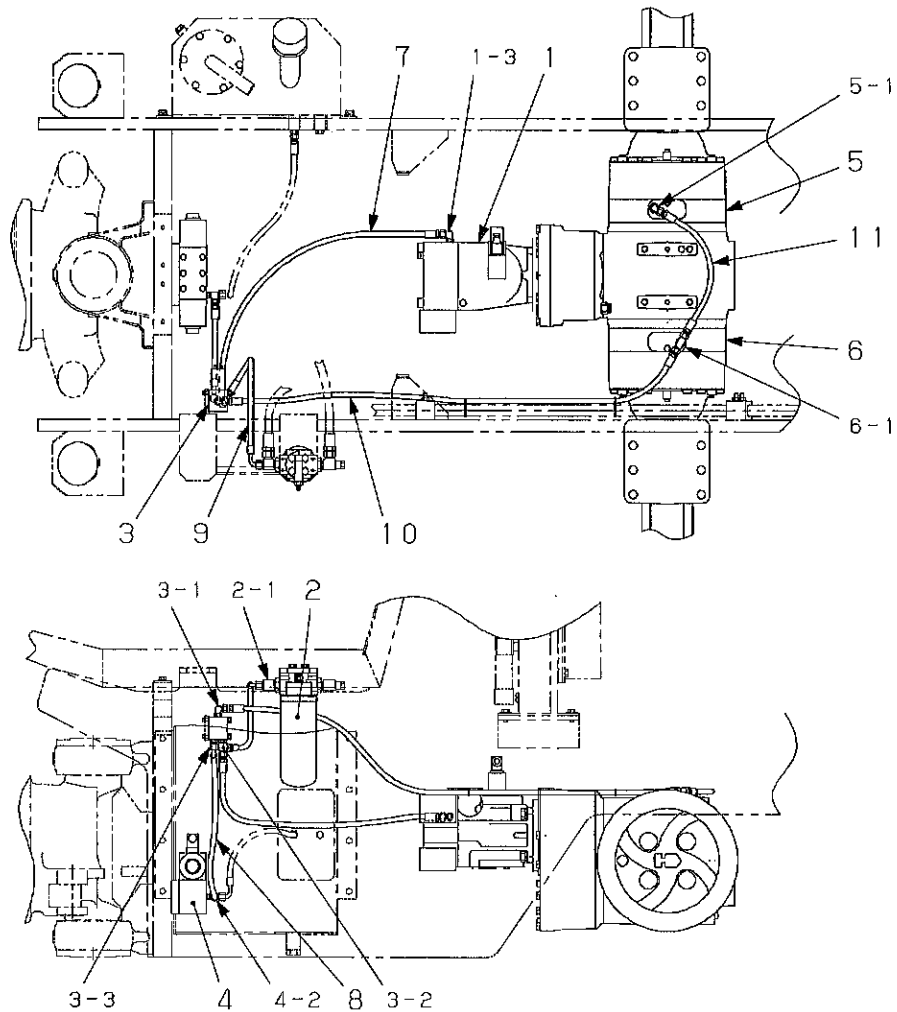

- (1) Propulsion motor (rear)
(1-3) Pilot supply port: 9/16-18UNF
- (2) Line filter
(2-1) OUT G3/4"
- (3) Brake solenoid valve
(3-1) Port A: G1/4"
(3-2) Port P: G1/4"
(3-3) Port T: G1/4"
- (4) Differential lock valve (manifold)
(4-2) Port Y: G1/4"

- (5) Brake (right)
(5-1) Port 1 : M14
- (6) Brake (left)
(6-1) Port P1 : M14
- (7) Hose : (1-3)→(3-2)
- (8) Hose : (3-3)→(4-2)
- (9) Hose : (2-1)→(3-2)
- (10) Hose : (3-1)↔(6-1)
- (11) Hose : (6-1)↔(5-1)

• The figures (such as 1-3 and 2-1) show each port and the arrow (↔; →) symbols show the hose connection and the direction of the flow of the oil.

1-4. Brake solenoid valve

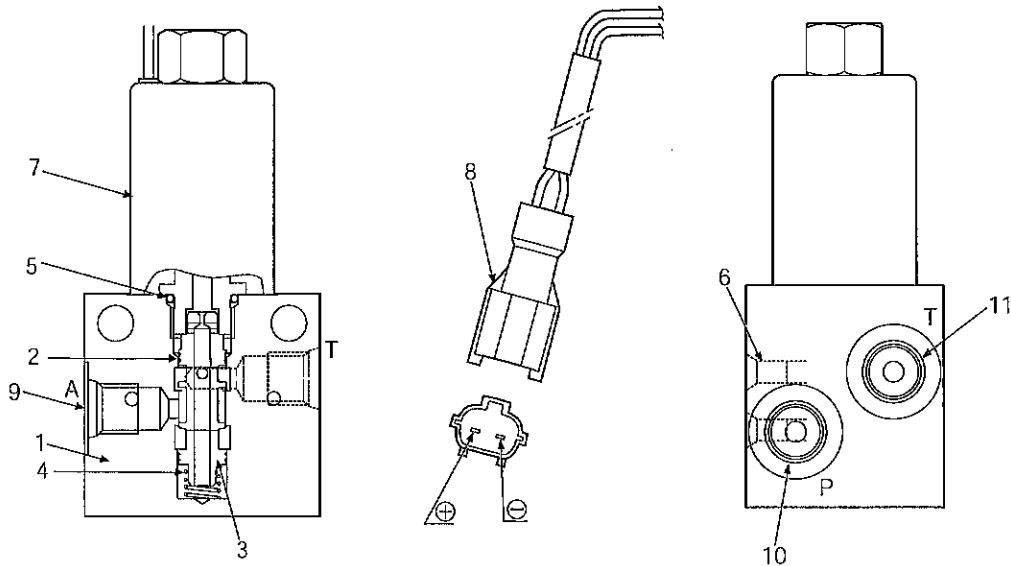

Electric circuit

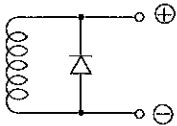

- | | | |
|---------------------|--------------------|--------------------|
| (1) Body | (6) Plug | (11) Port T (G1/4) |
| (2) Spool | (7) Solenoid | |
| (3) Spool | (8) Connector | |
| (4) Spring | (9) Port A (G1/4) | |
| (5) O-ring (1B P14) | (10) Port P (G1/4) | |

Specifications

- Rated pressure : 4.9 MPa (Ports A,P) (710 psi)
 : 0.5 MPa (Port T) (72 psi)
- Maximum flow : 75 L/min (20 gal. /min)
- Voltage : 12 V
- Power : 13 W

7-004

2. BRAKE STRUCTURE

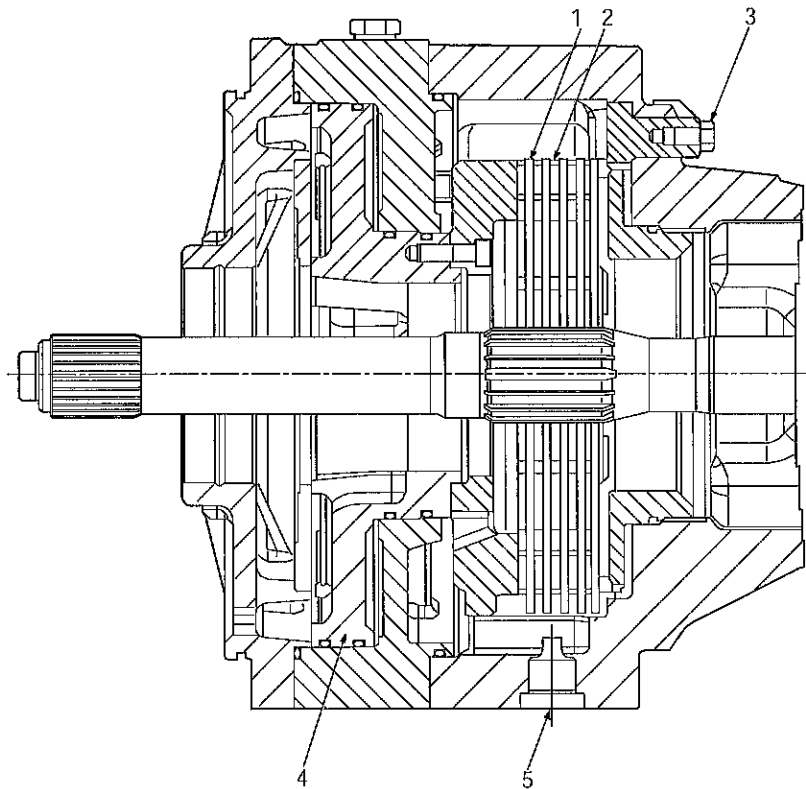

- (1) Friction plate
- (2) Separating plate
- (3) Bolt (for brake adjustment)
- (4) Piston
- (5) Drain plug

· Brake release pressure: 1.5~3.0 MPa (218~435 psi)

3. BRAKE ADJUSTMENT

3-1. Brake clearance adjustment

- 1) Turning the adjusting pinion (4) counterclockwise reduces the clearance between the brake discs.
 - Required rotational torque:
8~10 N·m (5.9~7.4 lbf·ft)

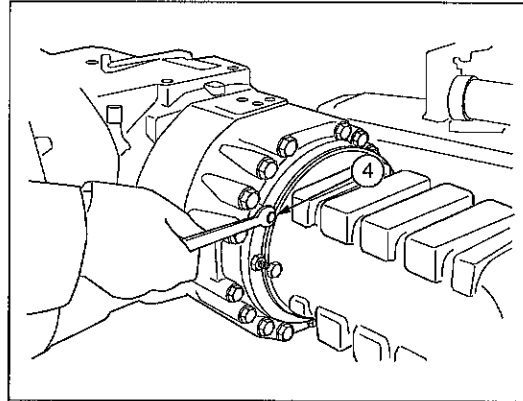

- 2) Initial adjustment after brake disc replacement
 - Rotate the adjusting pinion (4) clockwise, making the inside of the cover (6) and ring (5) adhere together.
 - To create an inside clearance of 1 mm (0.04 in.) between the cover (6) and ring (5), rotate the adjusting pinion (4) counterclockwise four complete turns.

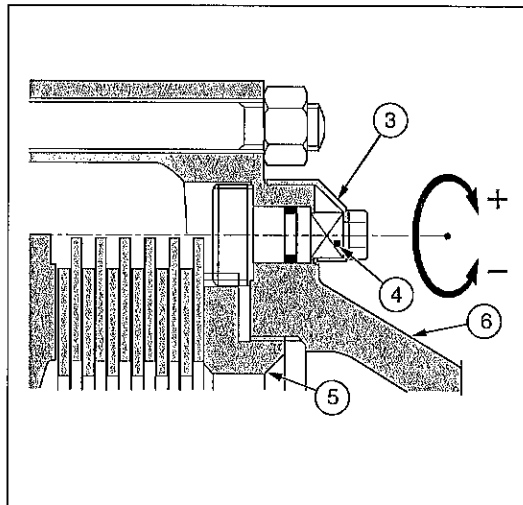

- ★ Pinion (4) adjustment quantity
: 0.25 mm/rotation
(0.01 in./rotation)
- ★ Brake disc assembly wear limit
: 2.4 mm (0.094 in.)

- 3) Attach the safety plate (3), and tighten the bolt (2).

 Bolt (2) : 11 N·m (8.1 lbf·ft)

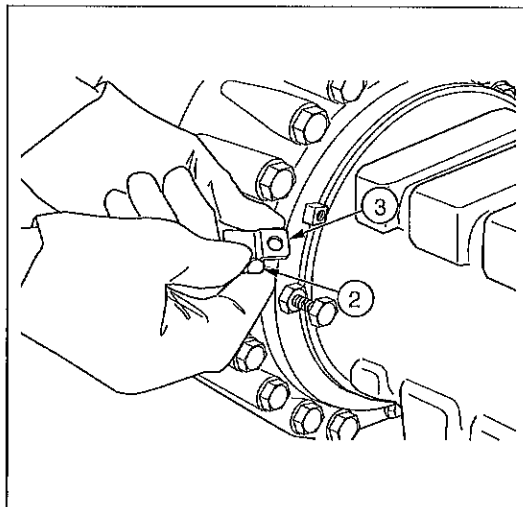

3-2. Manually releasing the brake

- 1) Loosen the nut (24).
 - Loosen the nut on the opposite side, too.
 - An applicable bolt (25) and nut (24) can be found on the opposite side, too.

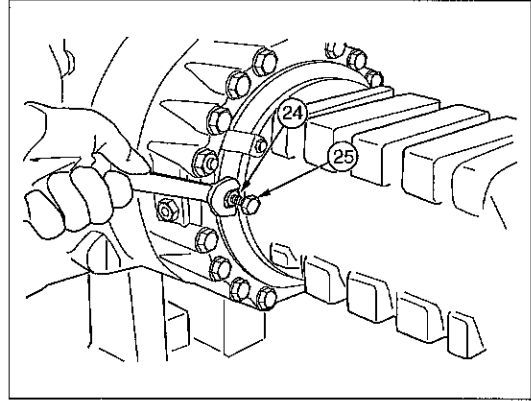

- 2) Tighten the bolt (25), and press it into the pressure plate (16).
 - Do the same with the bolt on the opposite side, too.

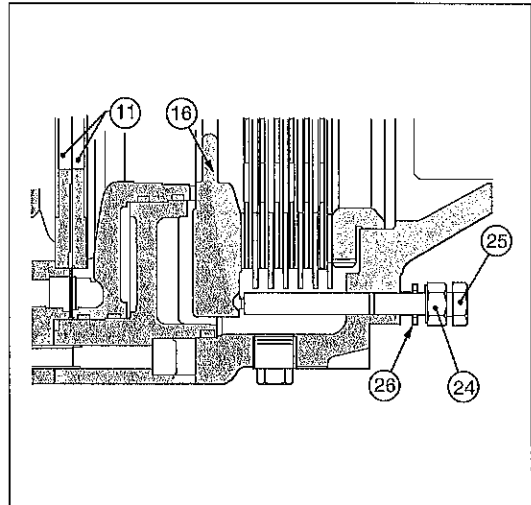

- 3) Alternately tighten the bolts (25) 1/4 turn each, and release the brake disc.

★ After the bolt end makes contact with the pressure plate (16), strictly observe not tightening the bolt (25) more than one complete turn.

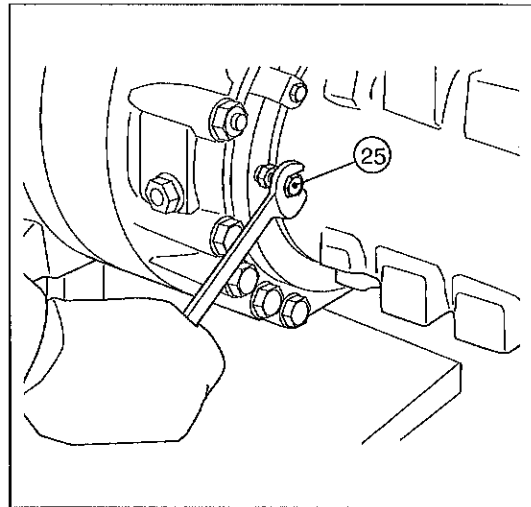

BRAKE ADJUSTMENT

4) Adjustment after manual release of brake

- ① Remove the bolt (25), nut (24), and seal washer (26).
- ② Replace the seal washer (26) with a new one.
- ③ Apply grease to the bolt (25) threads.
- ④ As shown in the figure on the right, install the bolt (25), nut (24), and seal washer (26).

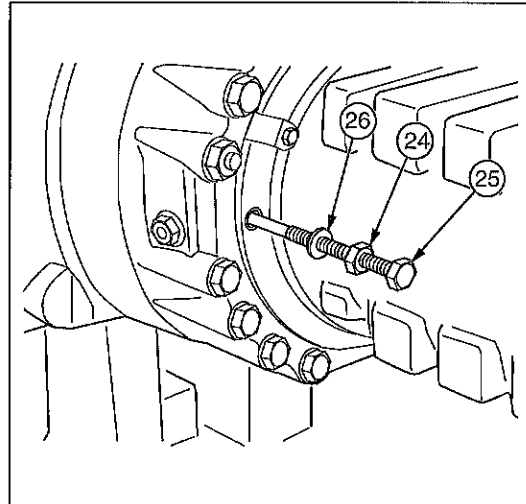

- ⑤ Adjust the bolt (25) to the dimensions shown in the figure on the right.
 - Similarly, adjust the bolt on the opposite side, too.

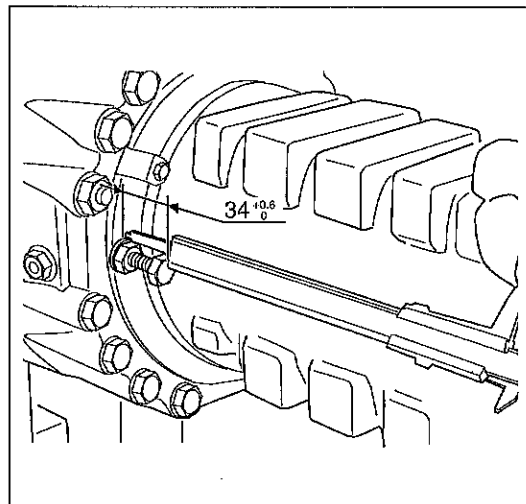

- ⑥ Tighten the nut (24), and firmly secure the bolt (25).

- ★ When tightening the nut (24), make sure that the bolt (25) does not move. After securing the bolt, check the dimensions of the bolt again.

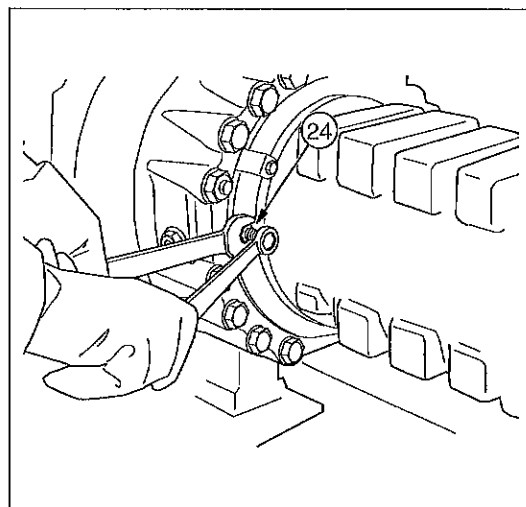

INSPECTION AND ADJUSTMENT

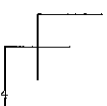
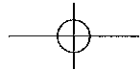
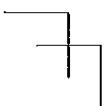
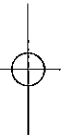
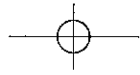
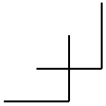

1. INSPECTION AND ADJUSTMENT

1-1. Inspection and Adjustment

1-1-1. Safety precautions for inspection and adjustment

⚠WARNING

Unexpected vehicle movement may cause a serious accident. When inspecting the machine while the engine is running, always follow the instructions below.

- Park the machine on level, flat ground.
- Apply the parking brake.
- Set a stopper in front and behind each drum or tire.
- Make sure that service personnel are given the appropriate information at the appropriate time.
- Make sure that no one can enter any hazardous area.

⚠CAUTION

Do not work on the hydraulic system while the engine is running and the system is hot and under pressure. Do not disconnect hydraulic hoses or fittings until the system has cooled and pressure has been properly relieved.

Before removing any plugs from the pressure measurement ports, always release any residual pressure from the piping and open the cap of the fluid tank to release and pressure.

⚠WARNING

Inadvertent starting the engine may cause a serious accident.

When inspecting the engine, make sure to exchange the appropriate cues and hand signal with the person at the operator station to avoid any accidents.

⚠CAUTION

Before inspecting inside of the engine compartment, always stop the engine.

Contact with the fan, V-belt or exhaust system parts while the engine is running may cause serious injury.



INSPECTION AND ADJUSTMENT

1-1-2. Preparation for inspection and adjustment

- Prepare the necessary measuring instruments. In addition, particularly when measuring pressure values, make sure to prepare the appropriate hoses, adapters and a plug removal tool for the pressure reading port.

- Make sure that the instruments to be used operate normally.

When handling the instruments, exercise sufficient caution not to drop or apply any impact to them. Doing so may adversely affect the calibration. Another important point is to inspect the instruments regularly. An instrument that does not start from the appropriate zero point may give an inaccurate reading.

1-1-3. Precautions for inspection and adjustment

- When performing inspections and adjustments, pay special attention to safety.
- For each inspection, always take three measurements for each measurement point. If the measurements significantly differ, the measurement method may be incorrect. In such a case, take measurements once again and calculate their average.

1-1-4. Warm-up

- Machinery will not exhibit their true performance under the cold condition. Before taking measurements, always warm up the engine and make sure that the fluid and engine coolant are warmed to their specified normal operating temperatures.

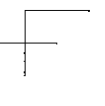
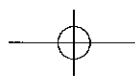
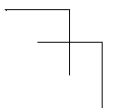
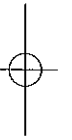
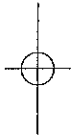
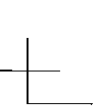
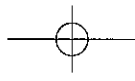

2. MEASUREMENT AND ADJUSTMENT OF PROPULSION CIRCUIT PRESSURE

2-1. Measurement

- Oil temperature during measurement:
 $50 \pm 5^{\circ}\text{C}$ ($122 \pm 41^{\circ}\text{F}$)

- ① Remove the plugs from the propulsion pump's gauge ports (1-5 and 1-6). Attach the pressure gauge through the adapter ②.
 - Gauge port: 9/16-18UNF
 - Forward-side gauge port: (1-6)
 - Reverse-side gauge port: (1-5)
 - Pressure gauge: 0 ~ 49 MPa (0 ~ 7105 psi)
- ② Press the parking brake switch, turn the parking brake "ON" and move the gear switch to the "first (gear)" position.
- ③ Start the engine. Then move the throttle lever to the high idling position.
- ④ Slowly operate the forward-reverse lever to the side to be measured, and measure the pressure.

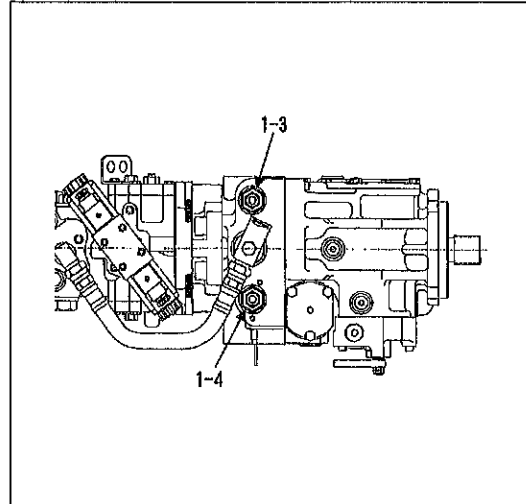

⚠ WARNING

Before performing the aforementioned operation, confirm that the parking brake operates properly.

- ⑤ After measuring, promptly return the forward-reverse lever to "neutral."

★ **Maximum circuit pressure: 41.8 ± 1.0 MPa
 (6061 ± 145) psi**

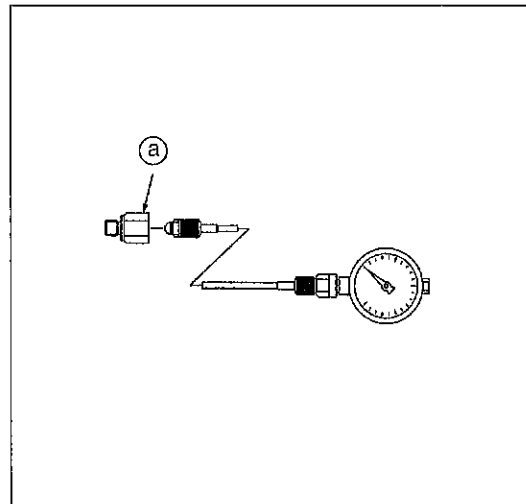

2-2. Adjustment

- If the measurement results indicate the pressure values deviating from the maximum circuit pressure, make an adjustment in accordance with the procedure described below.



- ① Check for evidence that the locknut (2) of the multifunction valve (1-3 or 1-4) was loose.
 - Multifunction valve (1-4): forward side
 - Multifunction valve (1-3): reverse side
- ② If evidence of looseness exists, watch the pressure gauge while setting the multifunction valve so that the maximum circuit pressure is achieved.
 - To adjust the pressure, loosen the locknut (2) and turn the adjustment screw (3).

Clockwise turning of adjustment screw:
Pressure rises.

Counterclockwise turning of adjustment screw:
Pressure drops.

Pressure change: 2.1 MPa/rotation
(305 psi/rotation)

- ③ If no evidence of looseness exists, remove the multifunction valve (1-3 or 1-4).
- ④ Check for dust lodged in the removed multifunction valve, and for damage to the seat surface.
- ⑤ If dust is present, disassemble and clean the multifunction valve.
- ⑥ If the seat surface is scratched or damaged, replace the multifunction valve.
- ⑦ After adjustment is completed, measure the pressure again. Confirm whether the pressure rises to the maximum circuit pressure range.

-  (1) Nut: 41 N·m (30 lbf·ft)
 (2) Nut: 9 N·m (6.6 lbf·ft)
 Multifunction valve (1-3 and 1-4):
 80 N·m (59 lbf·ft)

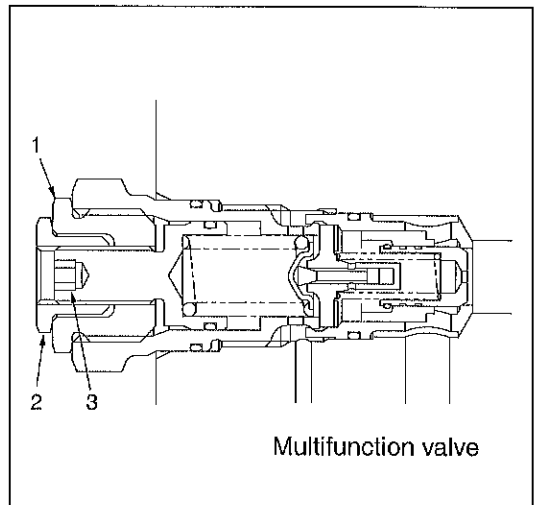
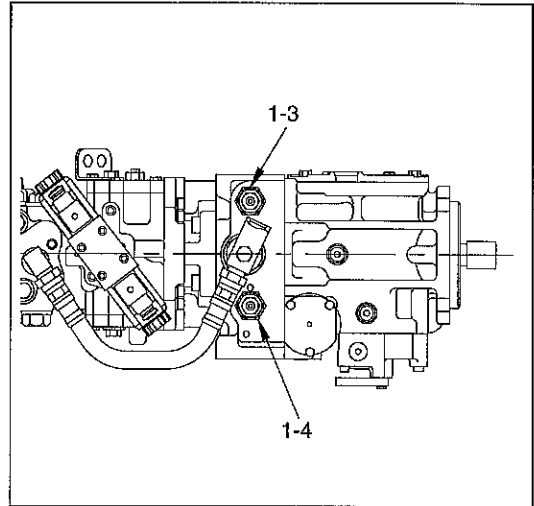

★ **Carefully disassemble and reassemble after taking steps to prevent foreign material from getting in.**

- Numbers such as 1-3 and 1-4 in the illustration correspond to the leader numbers in the propulsion pump drawing in section 2-3, "Hydraulic equipment specifications" (page 4-8).

3. MEASUREMENT AND ADJUSTMENT OF PROPULSION CHARGE CIRCUIT PRESSURE

Before measuring

- Since charge circuit oil is being supplied from the steering circuit, first confirm that the steering operation is normal.
- The propulsion charge circuits and vibration charge circuits consist of parallel circuits. Thus, in order to measure whether the propulsion charge circuit pressure is within the standard value, use the following operation to ensure that oil does not escape from the charge relief valve on the vibrator pump side.

- ① Remove the plug (1) from the charge relief valve (2-7) on the vibrator pump side.
- ② Insert a spacer ($\phi 12$ mm x t 10 mm) as shown in the figure on the right.
- ③ Attach the plug (1).

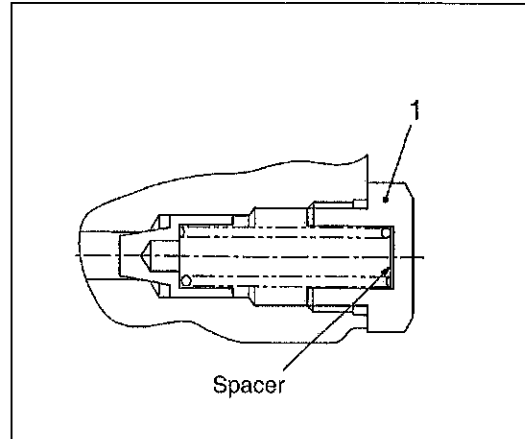

3-1. Measurement

- Oil temperature during measurement:
 $50 \pm 5^{\circ}\text{C}$ ($122 \pm 41^{\circ}\text{F}$)

- ① Remove the plug from the charge pressure gauge port (1-8). Attach the pressure gauge through the adapter (a).
 - Gauge port: 9/16-18UNF
 - Pressure gauge: 0 ~ 4.9 MPa (0 ~ 711 psi)
- ② Press the parking brake switch and turn the parking brake "ON".
- ③ Start the engine, move the throttle lever to the high idling position, and measure the pressure.

- ★ **Standard charge relief pressure setting:**
 1.9 ± 0.2 MPa (276 ± 29 psi)

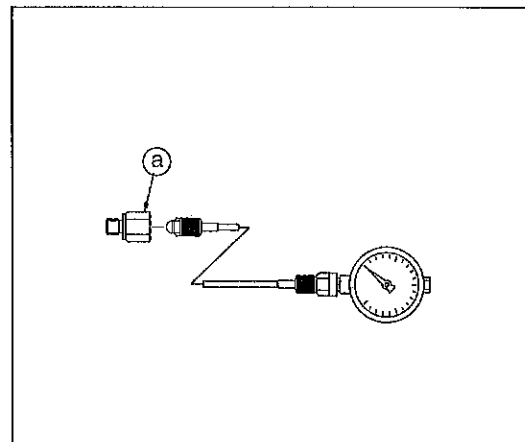
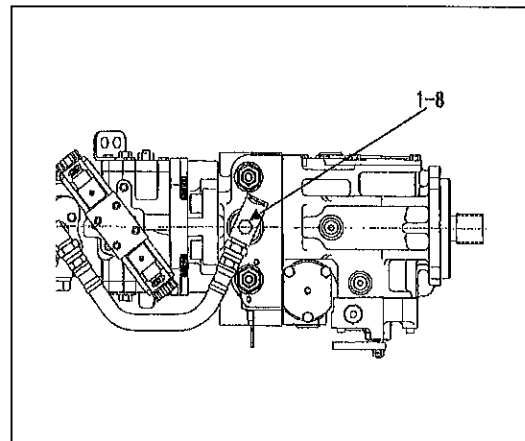

3-2. Adjustment

- If the measurement results indicate the pressure values deviating from the standard charge relief pressure setting, make an adjustment in accordance with the procedure described below.

- ① Check for evidence that the locknut (2) of the charge relief valve (1-10) was loose.
- ② If evidence of looseness exists, watch the pressure gauge while setting the charge relief valve so that the standard charge relief valve pressure setting is achieved.

- To adjust the pressure, loosen the locknut (2) and turn the adjustment screw (3).

Clockwise turning of adjustment screw:
Pressure rises.

Counterclockwise turning of adjustment screw:
Pressure drops.

Pressure change: 0.29 MPa/rotation
(42 psi/rotation)

- ③ If no evidence of looseness exists, remove the charge relief valve (1-10).
- ④ Check for dust lodged in the removed charge relief valve, and for damage to the seat surface.
- ⑤ If dust is present, disassemble and clean the charge relief valve.
- ⑥ If the seat surface is scratched or damaged, replace the charge relief valve.
- ⑦ After adjustment is completed, measure the pressure again. Confirm whether the pressure rises to the standard charge relief valve pressure setting range.

- ★ **Carefully disassemble and reassemble after taking steps to prevent foreign material from getting in.**

- Numbers such as 1-8 and 1-10 in the illustration correspond to the leader numbers in the propulsion pump drawing in section 2-3, "Hydraulic equipment specifications" (page 4-8).

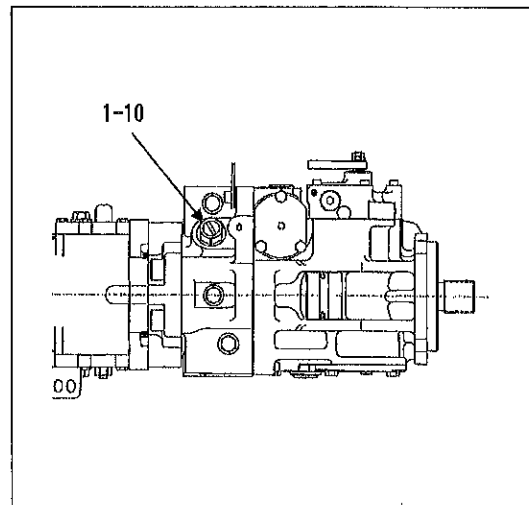
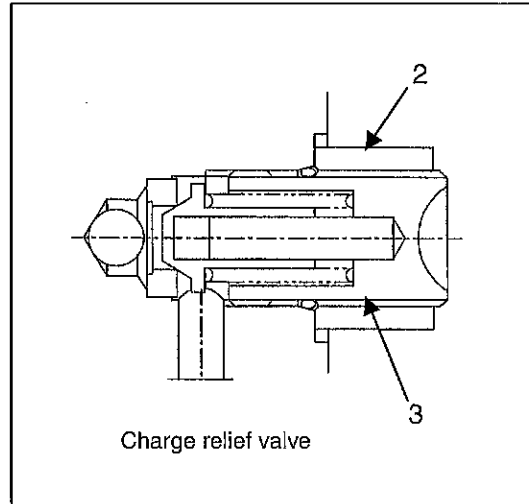

4. MEASUREMENT OF VEHICLE HIGH/LOW-SPEED CHANGE CIRCUIT PRESSURE

4-1. Measurement

- Oil temperature during measurement:
 $50 \pm 5^{\circ}\text{C}$ ($122 \pm 41^{\circ}\text{F}$)

① Remove the plugs from the rear propulsion motor's gauge ports (4 and 5). Attach the pressure gauge through the adapter (a).

- Gauge port: 9/16-18UNF
- Low-speed-side (first (gear)) gauge port: (4)
- High-speed-side (second (gear)) gauge port: (5)
- Pressure gauge: 0 ~ 4.9 MPa (0 ~ 711 psi)

② Press the parking brake switch, turn the parking brake "ON" and move the speed change switch to the "first (gear)" or "second (gear)" position.

③ Start the engine, move the throttle lever to the high idling position, and measure the pressure.

- ★ **Standard charge relief pressure setting:**
 $1.9 \pm 0.2 \text{ MPa}$ ($276 \pm 29 \text{ psi}$)

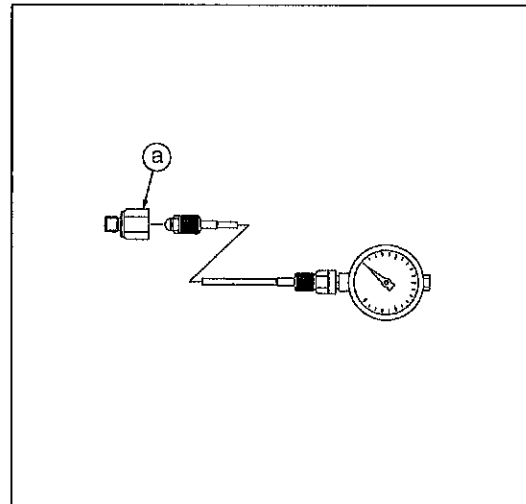
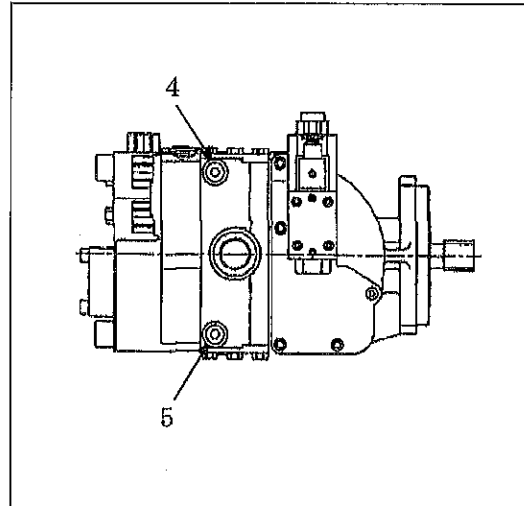

5. MEASUREMENT OF PARKING BRAKE RELEASE PRESSURE

5-1. Measurement

- Oil temperature during measurement:
 $50 \pm 5^\circ\text{C}$ ($122 \pm 41^\circ\text{F}$)

- ① Disconnect the hose (2) that is connected to the brake solenoid valve (1). Attach the pressure gauge through the adapter (b).
 - Gauge port: G1/4
 - Pressure gauge: 0 ~ 4.9 MPa (0 ~ 711 psi)
- ② Confirm that the forward-reverse lever is in the "neutral position".
- ③ Press the parking brake switch and turn the parking brake "ON".
- ④ Start the engine. Then move the throttle lever to the high idling position.
- ⑤ Turn the parking brake switch "OFF", and measure the brake release pressure.

- ★ **Standard charge relief pressure setting:**
 $1.9 \pm 0.2 \text{ MPa}$ ($276 \pm 29 \text{ psi}$)

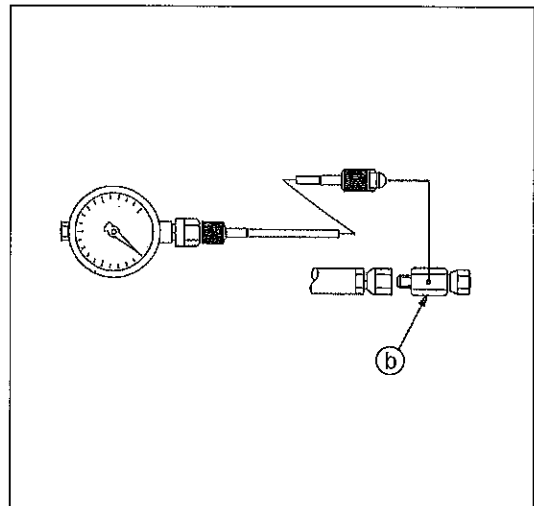
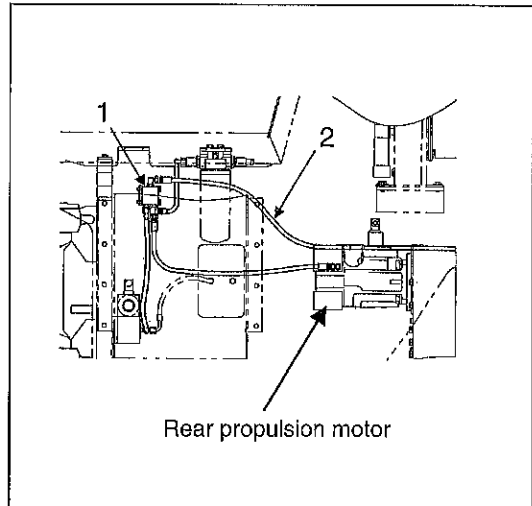

6. MEASUREMENT AND INSPECTION OF VIBRATOR CIRCUIT PRESSURE

6-1. Measurement

- Oil temperature during measurement:
 $50 \pm 5^{\circ}\text{C}$ ($122 \pm 41^{\circ}\text{F}$)

- ① Remove the plugs from the gauge ports (1 and 2) that are equipped with adapters attached to the vibrator pump. Attach the pressure gauge through the adapter ㉓.
 - Gauge port: 7/16-20UNF
 - High-amplitude-side gauge port: (1)
 - Low-amplitude-side gauge port: (2)
 - Pressure gauge: 0 ~ 34.3 MPa (0 ~ 4975 psi)
- ② Press the parking brake switch and turn the parking brake "ON".
- ③ Start the engine. Then move the throttle lever to the high idling position.
- ④ Press the vibrator switch and turn vibration "ON". Measure the maximum value of vibrator circuit pressure.

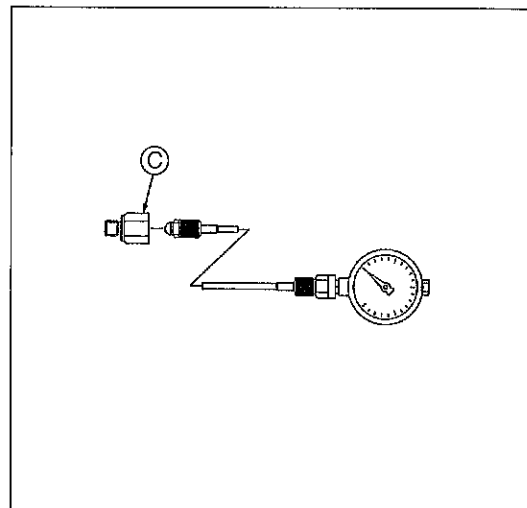
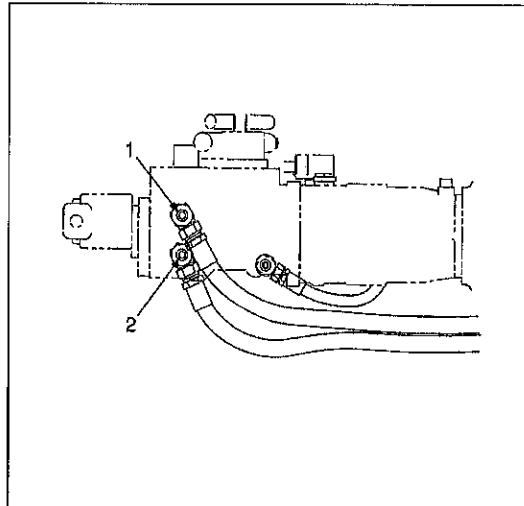

NOTE:

If the vehicle is subjected to vibration for a long period while in a stopped condition, the vibrator bearing can get burned. Therefore, use ample care.

- ⑤ After measuring, promptly turn the vibration "OFF".

★ **Maximum standard vibration pressure setting: 25.0 ± 1.0 MPa (3625 ± 145 psi)**

6-2. Inspection

- If the measurement results indicate the pressure values deviating from the maximum standard vibration pressure setting, conduct an inspection in accordance with the procedure described below.
- Since the high-pressure relief valve is a fixed type, the pressure setting cannot be adjusted.

- ① Remove the high-pressure relief valve (2-3 or 2-4).
 - High-pressure relief valve (2-3): low-amplitude side
 - High-pressure relief valve (2-4): high-amplitude side
- ② Check the removed high-pressure relief valve for dust and other abnormalities.
- ③ If dust is present, disassemble and clean the high-pressure relief valve.
- ④ If, after disassembly and cleaning, you remeasure the pressure and find that it deviates from the maximum standard vibration pressure setting, replace the high-pressure relief valve.
- ⑤ After the inspection is completed, measure the pressure again. Confirm whether the pressure rises to the maximum standard vibration pressure setting range.

 High-pressure relief valves (2-3 and 2-4):
 $176 \text{ N}\cdot\text{m}$ (130 lbf·ft)

- ★ **Carefully disassemble and reassemble after taking steps to prevent foreign matter from getting in.**

- Numbers such as 2-3 and 2-4 in the illustration correspond to the leader numbers in the propulsion pump drawing in section 2-3, "Hydraulic equipment specifications" (page 4-8.)

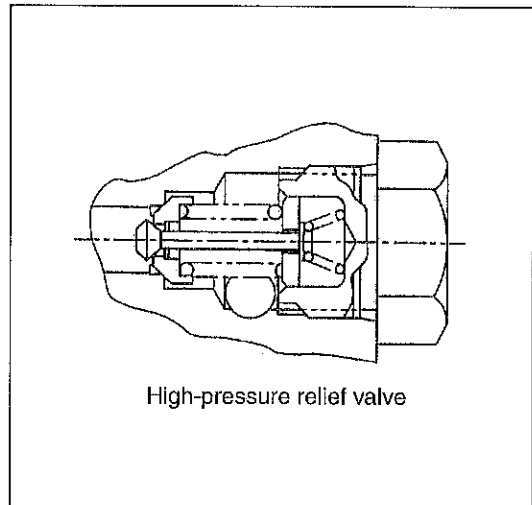
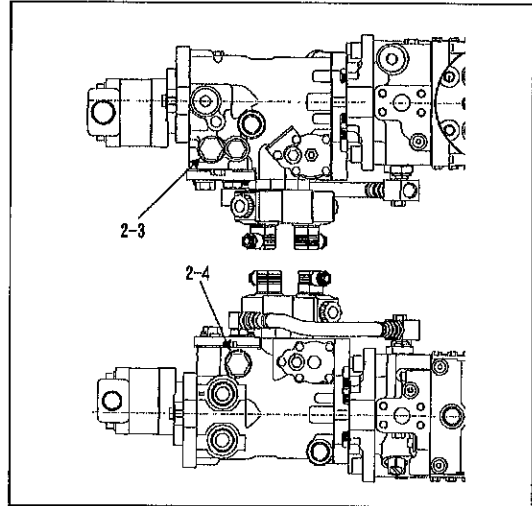

7. MEASUREMENT AND INSPECTION OF VIBRATION CHARGE CIRCUIT PRESSURE

CHARGE CIRCUIT PRESSURE

Before measuring

- Since charge circuit oil is being supplied from the steering circuit, first confirm that the steering operation is normal.
- The propulsion charge circuits and vibration charge circuits consist of parallel circuits. Thus, in order to measure whether the vibration charge circuit pressure is within the standard value, use the following operation to ensure that oil does not escape from the charge relief valve on the propulsion pump side.

- ① Loosen the locknut (2) from the charge relief valve (1-10) on the propulsion pump side.
- ② Tighten the adjustment screw (3) by one complete turn.

Pressure change: 0.29 MPa/rotation
(42 psi/rotation)

7-1. Measurement

- Oil temperature during measurement:
 $50 \pm 5^{\circ}\text{C}$ ($122 \pm 41^{\circ}\text{F}$)
- ① Remove the plug from the charge pressure gauge port (1-8). Attach the pressure gauge through the adapter (a).
 - Gauge port: 9/16-18UNF
 - Pressure gauge: 0 ~ 4.9 MPa (0 ~ 711 psi)
 - ② Press the parking brake switch and turn the parking brake "ON".
 - ③ Start the engine, move the throttle lever to the high idling position, and measure the pressure.

★ **Standard charge relief pressure setting:**
 $2.34 \pm 0.2 \text{ MPa}$ ($339 \pm 29 \text{ psi}$)

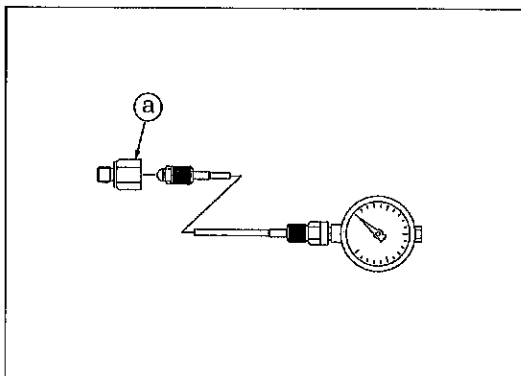
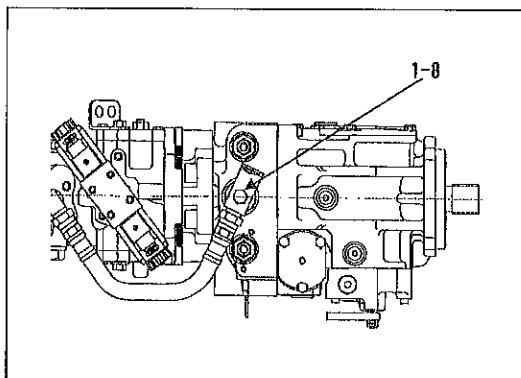
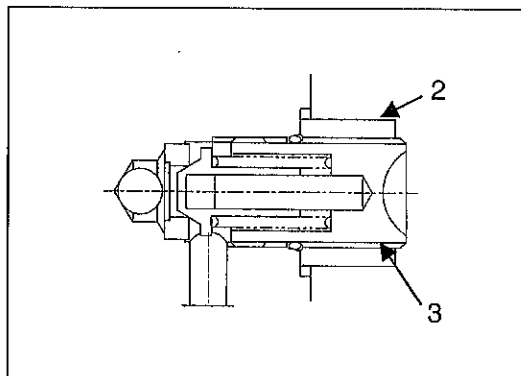
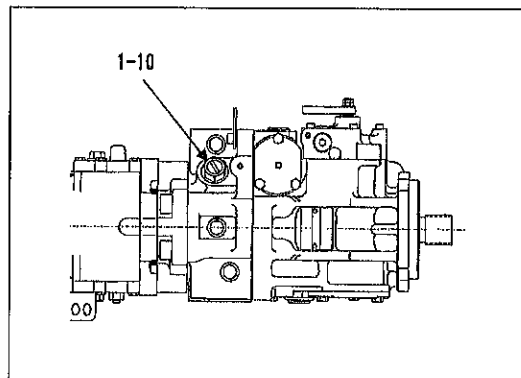

7-2. Inspection

- If the measurement results indicate the pressure values deviating from the standard charge relief pressure setting, conduct an inspection in accordance with the procedure described below.
- Since the vibration charge relief valve is a fixed type, the pressure setting cannot be adjusted.

- ① Remove the vibration charge relief valve (2-7).
- ② Check the removed vibration charge relief valve for dust and other abnormalities.
- ③ If dust is present, disassemble and clean the vibration charge relief valve.
- ④ If, after disassembly and cleaning, you remeasure the pressure and find that it deviates from the standard charge pressure setting, replace the vibration charge relief valve.
- ⑤ After the inspection is completed, measure the pressure again. Confirm whether the pressure rises to the standard charge relief pressure setting range.

 (2-7) Vibration charge relief valve:
74 N·m (55 lbf·ft)

★ **Carefully disassemble and reassemble after taking steps to prevent foreign material from getting in.**

- Numbers 1-8, 1-10, and 2-7 in the illustration correspond to the leader numbers in the propulsion pump drawing in section 2-3, "Hydraulic equipment specifications" (page 4-8).

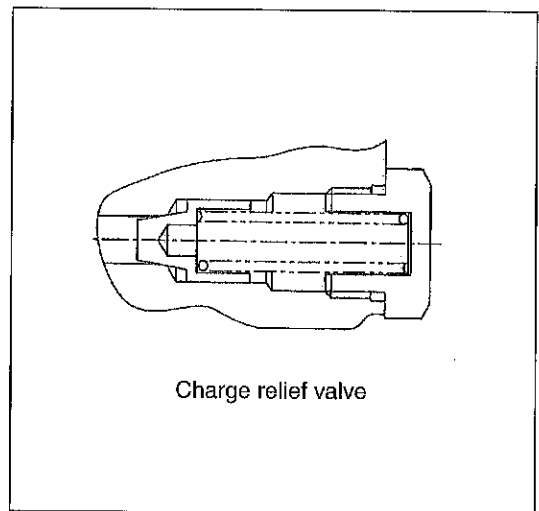
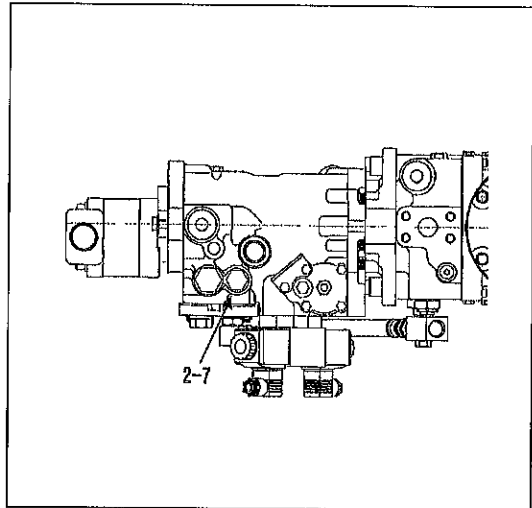

8. MEASUREMENT AND INSPECTION OF STEERING CIRCUIT PRESSURE

8-1. Measurement

- Oil temperature during measurement:
 $50 \pm 5^{\circ}\text{C}$ ($122 \pm 41^{\circ}\text{F}$)

- ① Remove the hose (1) from the steering pump's discharge side. Attach the pressure gauge through the adapter (d).
 - Adapter size: G3/4
 - Pressure gauge: 0 ~ 24.5 MPa (0 ~ 3553 psi)
- ② Confirm that the forward-reverse lever is properly in the neutral position.
- ③ Start the engine. Then move the throttle lever to the high idling position.
- ④ Turn the steering wheel and operate the relief valve. Measure the pressure.

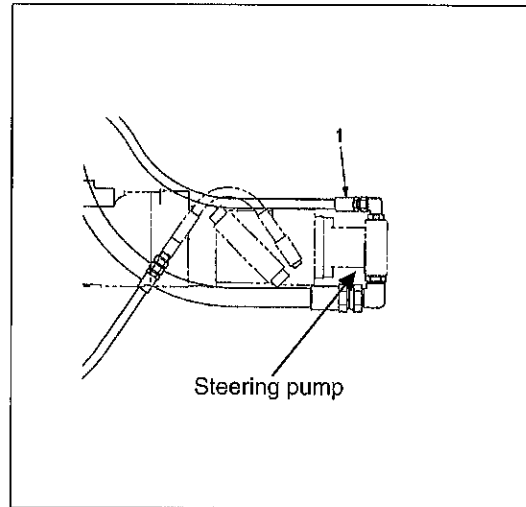

⚠ WARNING

Before turning the steering wheel, confirm that no one is near the vehicle's bends spots.

- ★ Maximum standard circuit pressure:
 16.89 ± 1.0 MPa (2449 ± 145 psi)

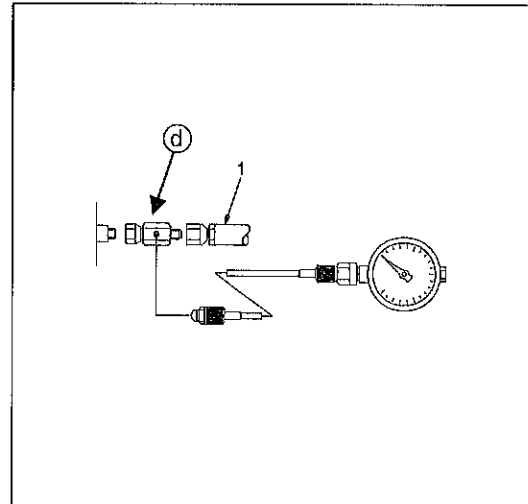

8-2. Inspection

- If the measurement results indicate the pressure values deviating from the maximum standard circuit pressure, make an adjustment in accordance with the procedure described below.
- Since the vibration charge relief valve is a fixed type, the pressure setting cannot be adjusted.

- ① Remove the relief valve (2) from the Orbitrol.
- ② Check the removed relief valve for dust, damage to the seat surface, and other abnormalities.
- ③ If dust is present, clean the relief valve. Then reattach it.
- ④ If there is damage to the seat surface or other abnormalities, replace the relief valve.
- ⑤ After the inspection is completed, measure the pressure again. Confirm whether the pressure rises to the maximum standard circuit pressure range.

- ★ **Carefully disassemble and reassemble after taking steps to prevent foreign material from getting in.**

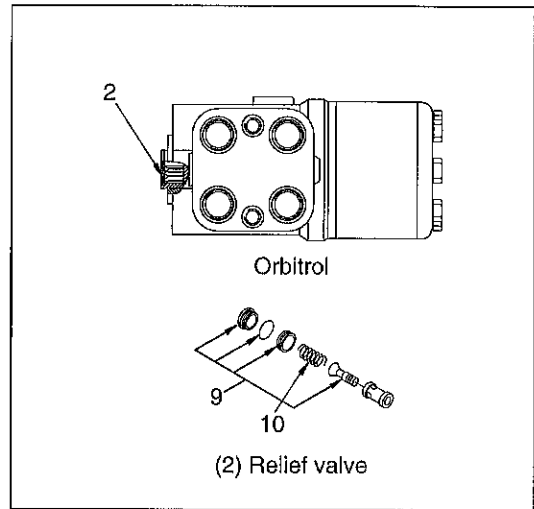

9. ADJUSTMENT OF THROTTLE LEVER LINKAGE

9-1. Adjustment

- If the throttle lever linkage was replaced or the maximum no-load rotational speed (minimum no-load rotational speed) deviates from the standard value, make an adjustment in accordance with the procedure described below.
- Make the adjustment after amply warming up the engine.
- Oil temperature during measurement:
 $50 \pm 5^{\circ}\text{C}$ ($122 \pm 41^{\circ}\text{F}$)

- ① Set the throttle lever (1) to the minimum no-load rotational speed position.
- ② Attach the throttle cable (2) to the fuel injection pump's control lever (3).
- ⑤ Start the engine.
- ⑥ Loosen the locknut (4).
- ⑦ Using the stop bolt (5), adjust so that the standard minimum no-load rotational speed is achieved.

★ **Standard minimum no-load rotational speed**
 : $900 \pm 25 \text{ min}^{-1}$

- ⑧ Set the throttle lever (1) in the maximum no-load rotational speed position.
- ⑨ Loosen the locknut (7).
- ⑩ Using the stop bolt (8), adjust so that the control lever (3) contacts the stopper (6).

★ **Standard maximum no-load rotational speed**
 : $2230_{-50}^0 \text{ min}^{-1}$

- ⑪ Using the locknuts (4 and 7), firmly secure the stop bolts (5 and 8).
- ⑫ Confirm that the engine speed is within the standard range.

★ **If the maximum no-load rotational speed is not in the standard range even when the control lever (3) is against the stopper (6), adjust the injection nozzle, or repair or replace the fuel injection pump.**

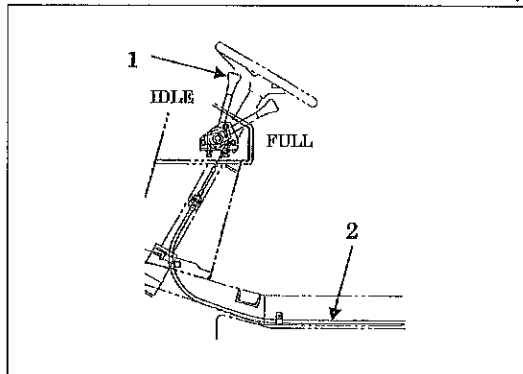
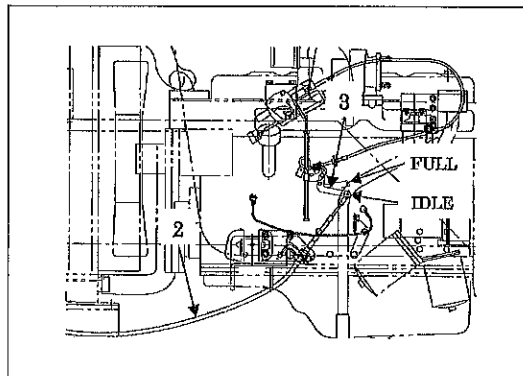
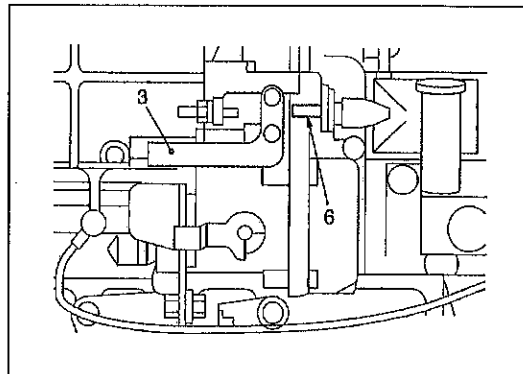
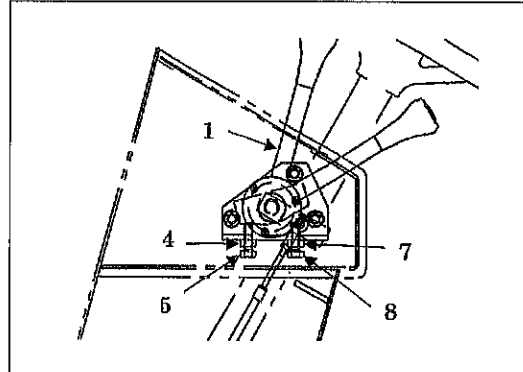

10. ADJUSTMENT OF FORWARD-REVERSE LEVER LINKAGE

10-1. Adjustment

- If the forward-reverse lever linkage was replaced, make an adjustment in accordance with the procedure described below.
- The neutral position of the forward-reverse lever (1) and the maximum stroke on the forward-reverse side are positioned by notches.

- ① Firmly secure the forward-reverse lever (1) in the neutral position.
- ② Confirm the stroke of the control lever (3) on the propulsion pump side.

★ **Specified dimension of control lever (3)**
c: 24~29 mm (0.94~1.14 in)

- ③ Firmly secure both ends of the control cable (2).

★ **Specified dimensions of control cable (2) ends**
a: 238 mm (9.37 in)
b: 210 mm (8.27 in)

- ④ After the work is completed, confirm the following items:
 - The forward-reverse lever operates smoothly.
 - The stroke of the control lever (3) on the propulsion pump side is the specified dimension.
 - The interlock switch (4) should not operate with the forward-reverse lever in the neutral range.
 - The backup buzzer switch (5) should operate when the forward-reverse lever is shifted into the reverse side.

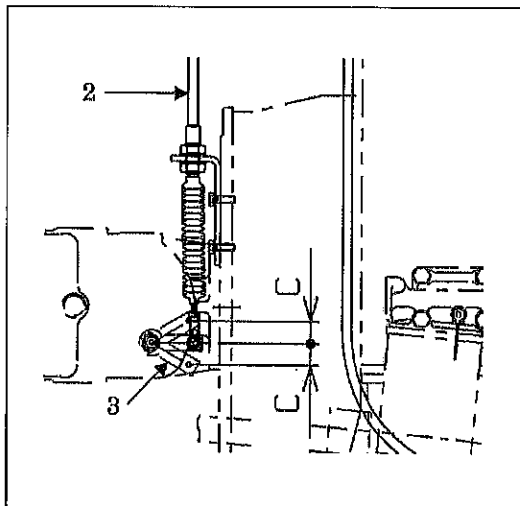

ADJUSTMENT OF FORWARD-REVERSE LEVER LINKAGE

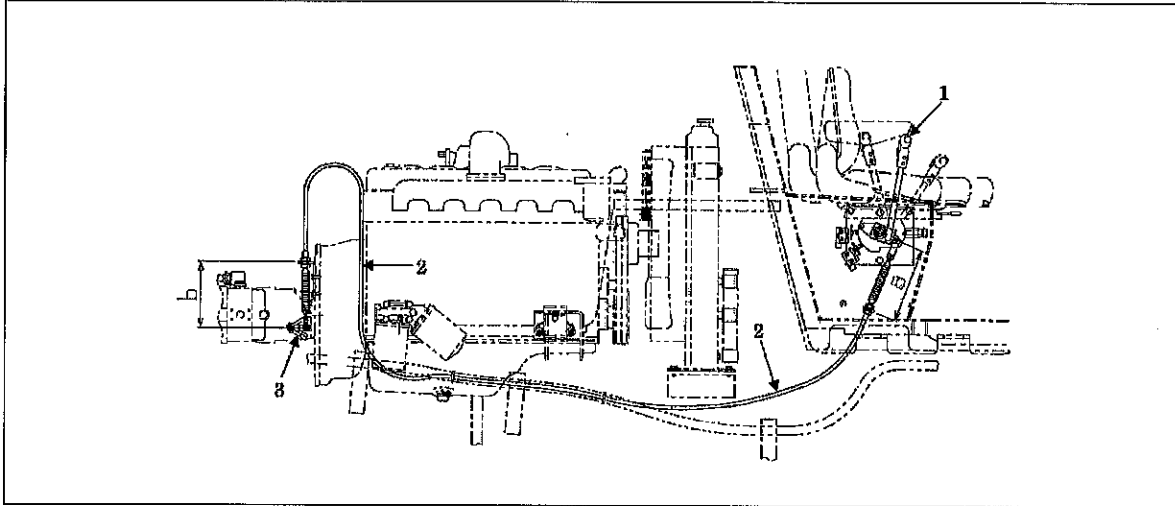

8-017

TROUBLESHOOTING

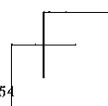
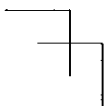
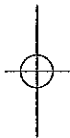
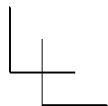
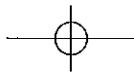
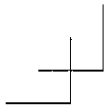

1. TROUBLESHOOTING

1-1. Safety precautions for troubleshooting

WARNING

Unexpected vehicle movement may cause a serious accident. When inspecting the machine while the engine is running, always follow the instructions below.

- Park the machine on level, flat ground.
- Apply the parking brake.
- Set a stopper in front and behind each drum or tire.
- Make sure that service personnel are given the appropriate information at the appropriate time.
- Make sure that no one can enter any hazardous area.

CAUTION

Do not work on the hydraulic system while the engine is running and the system is hot and under pressure. Do not disconnect hydraulic hoses or fittings until the system has cooled and pressure has been properly relieved.

Before removing any plugs from the pressure measurement ports, always release any residual pressure from the piping and open the cap of the fluid tank to release and pressure.

WARNING

Inadvertent starting the engine may cause a serious accident.

When inspecting the engine, make sure to exchange the appropriate cues and hand signal with the person at the operator station to avoid any accidents.

CAUTION

Before inspecting inside of the engine compartment, always stop the engine.

Contact with the fan, V-belt or exhaust system parts while the engine is running may cause serious injury.

1-2. Important information for troubleshooting

Before conducting troubleshooting, it is important to carefully read the operation manual and workshop manual and understand the electric circuits for each component as well as the structure and function of each system. Sufficient knowledge of the systems will enable you to identify a possible cause much faster.

A fault or problem may seem to be related to many different factors. To identify the true cause, some experience is needed.

To perform the appropriate troubleshooting, it is important to learn not only the normal operations of the systems but also the possible symptoms that may occur when an abnormal condition is present. This chapter explains the possible causes and remedies for likely incidents taken from past experience.

1-3. Before starting a troubleshooting session

The information in this section is provided to assist the troubleshooter in understanding the systems and quickly determine the causes when operating abnormalities occur.

The following steps are recommended:

1. If not familiar with the machine, study the Operator's Manual and this Shop Manual.
2. Check with the operator for full details of the trouble, ask questions.
3. Verify the trouble by warming up the machine and operating it. Check the problem yourself.
4. Identify the problem with either a mechanical, hydraulic or electrical system source.
5. Isolate the problem to a particular component or circuit.
6. Eliminate the simplest or easiest to check possibilities first to prevent unnecessary disassembly of components.
7. Following repair or replacement of any parts, perform operational tests to verify that the problem has been eliminated and the performance of all the systems is normal.

1-4. Wire color code

| | | | | | | | | | | | |
|-----|-------------------------|-----|-------------------------|-----|------------------------------|-----|-------------------------------|----|-------------------------|----|-------------------------|
| B | Black | BrY | Brown/ Yellow stripe | L | Blue | LgY | Light green/ Yellow stripe | W | White | YL | Yellow/ Blue stripe |
| BR | Black/ Red stripe | G | Green | LR | Blue/ Red stripe | R | Red | WB | White/ Black stripe | YR | Yellow/ Red stripe |
| BW | Black/ White stripe | GB | Green/ Black stripe | LW | Blue/ White stripe | RB | Red/ Black stripe | WL | White/ Blue stripe | YW | Yellow/ White stripe |
| BY | Black/ Yellow stripe | GL | Green/ Blue stripe | LY | Blue/ Yellow stripe | RG | Red/ Green stripe | WR | White/ Red stripe | Gy | Gray |
| Br | Brown | GR | Green/ Red stripe | Lg | Light green | RL | Red/ Blue stripe | WY | White/ Yellow stripe | O | Orange |
| BrB | Brown/ Black stripe | GW | Green/ White stripe | LgB | Light green/ Black stripe | RW | Red/ White stripe | Y | Yellow | Sb | Sky blue |
| BrR | Brown/ Red stripe | GY | Green/ Yellow stripe | LgR | Light green/ Red stripe | RY | Red/ Yellow stripe | YB | Yellow/ Black stripe | P | Pink |
| BrW | Brown/ White stripe | | | LgW | Light green/ White stripe | | | YG | Yellow/ Green stripe | | |

2. FAULT DIAGNOSIS OF ELECTRICAL SYSTEM

2-1. When performing electrical system fault diagnosis

⚠ WARNING

When a failure occurs due to a faulty contact or other such cause, use caution because the equipment can return to normal during an inspection and suddenly operate properly.

2-1-1. Precautions to take during electric circuit fault diagnosis

- When disconnecting or connecting a connector, be sure to turn the power supply OFF.
- Since connectors are not numbered, be sure to affix alignment marks so that you can restore them to their original condition.
- Before making a diagnosis, check related connectors for faulty connections.
(Check by disconnecting and reconnecting related connectors several times.)
- Before proceeding to the next step, be sure to return the disconnected connectors to their original condition.
- When diagnosing a circuit (measuring the voltage, resistance, continuity and current), move related wiring and connectors several times, and check whether the tester's numerical values change. (If values change, faulty contact in the circuit is possible.)

2-1-2. Inspection of electrical system

Operate the applicable switches and turn the relays ON and OFF. Ultimately, if the solenoid valve operates (makes a sound) and the pump runs, the electrical system is OK.

If there is a failure (fault), narrow the range of the inspection to the six broad steps described below.

1) Grounding inspection

- Check for disconnected or loose grounding. If rust is present (which can cause faulty contact), remove the rust.

2) Fuse inspection

2-1) Check for fuse disconnections and corrosion.

2-2) If fuse is burned out

Check whether a pump or valve (that is supposed to be protected by a burnt fuse) burned, and whether there is a burning odor.

If a pump or valve is not burned particularly, check the harness for signs of burning. If it is burned, replace it.

If a fuse is burnt and a relay along the pathway has failed, replace it. And if there is a timer, replace the timer, too. If a switch visually appears to be unsatisfactory (burned, melted, etc.) even though it operates, replace it.

- Simply replacing a fuse may not eliminate the true cause of a problem, and over current may flow again. Also, if over current secondarily causes an electrical path to fail (such as a wiring meltdown inside a solenoid valve), current will not flow. Thus, a fuse may not burn out, but it also will not operate. If you do not know the location of burning or of an odor, investigate as described follows

FAULT DIAGNOSIS OF ELECTRICAL SYSTEM

2-3) How to find cause of failure when fuse burnout is reproduced

- ① Turn the ignition switch OFF, and remove the connector from the load (valve, pump).
- ② Referring to the circuit diagram, remove electrical parts that are connected to the circuit, such as relays, timers and diodes.
- ③ Turn the ignition switch ON, and see whether the conditions can be reproduced.
- ④ If the conditions are reproduced, a part such as a relay may have caused a short between the previous harness and ground (vehicle body). (Replace the harness.) If the conditions are not reproduced, check for signs of burning (odor) on the removed electrical parts.
- ⑤ If there is no problem, turn the ignition switch OFF and reattach the parts.
- ⑥ Turn the ignition switch ON and try again.
- ⑦ If the conditions are reproduced with this action, the problem was caused by a short between the harness and ground (vehicle body) that followed the attached electrical part. (Replace the harness.)
- ⑧ If the conditions are not reproduced, turn the ignition switch OFF, and connect the loads (valve and pump) one at a time. Turn the ignition switch ON and try again to see whether the fuse burnout is reproduced.
- ⑨ If the fuse burnout is reproduced, whatever was added at that time (including a harness added electrically) will be the cause of the failure.

- Even if the fuse is not burnt and the valve or pump is not burned, the valve or pump may be damaged electrically and may not operate. There may simply be a disconnection in the interior or an abnormal heat-up.
- Even if the fuse is not burnt, abnormal heat-up (hot enough to cause burns if touched) may occur if a relay, timer, diode or other semiconductor fails.

3) Connector inspection

- Is a connector disconnected or loose?
- If faulty contact is suspected

Turn the ignition switch OFF. Then disconnect and check the connectors (including relay and switch sockets). If the terminal has no luster, faulty contact due to oxidation can be suspected. Therefore, polish the terminal by inserting and removing the connector (relay, switch) repeatedly at least five times. (Luster will return.)

4) Relay inspection (Check ON/OFF operation by sound.)

- Conduct without running the engine. (If you run the engine, you cannot hear the sound of operation.)

Sound heard : The relay and wiring on the relay coil side are normal.

No sound heard : Turn the ignition switch OFF temporarily, replace the relay, and inspect again.

Sound heard : A relay failure occurred.

Still no sound : Using a tester, check the harness.

Continuity : Turn the ignition switch OFF temporarily, disconnect the relay and check for continuity between the harness-side grounding terminal (color: black) and vehicle body ground. (If there is none, replace the harness.)

Voltage : With the relay disconnected, turn the ignition switch ON and turn the operating switch ON. 24V (or 12V) (between vehicle body ground) should not reach the relay coil input terminal. Confirm this.

Identify the location (section) to which 24V (or 12V) reaches. Then replace the harness or take other action.

FAULT DIAGNOSIS OF ELECTRICAL SYSTEM

- 5) Solenoid valve inspection (Check ON/OFF operation by sound.)
- Conduct without running the engine. (If you run the engine, you cannot hear the sound of operation.)
- Sound heard : The electrical system is normal.
- No sound heard : Check with a tester.
- Continuity : ① Turn the ignition switch OFF temporarily, disconnect the connector and check for continuity between the harness-side grounding terminal (color: black) and vehicle body ground. (If there is none, replace the harness.)
- ② Is the solenoid valve coil burnt?
(Turn the ignition switch OFF, disconnect the connector and check the resistance between the solenoid valve terminal.)
- Voltage : With the connector disconnected, turn the ignition switch ON and check whether 24V (or 12V) exists between the harness-side connector and vehicle body ground.
- If YES : Replace the valve.
- If NO : Investigate and identify the location (section) to which 24V (or 12V) reaches. Then replace the harness or take other action.
- 6) Harness check
- If an incomplete disconnection inside the harness is suspected, wiggle (move) the harness during the relay inspection and solenoid valve inspection to see whether the relay (valve) operates incorrectly.
 - Check for burned areas of the harness.
 - Turn the ignition switch OFF, disconnect the connector and check the continuity, referring to the circuit diagram and wiring coloring.

FAULT DIAGNOSIS OF ELECTRICAL SYSTEM

Fig. : 2-2

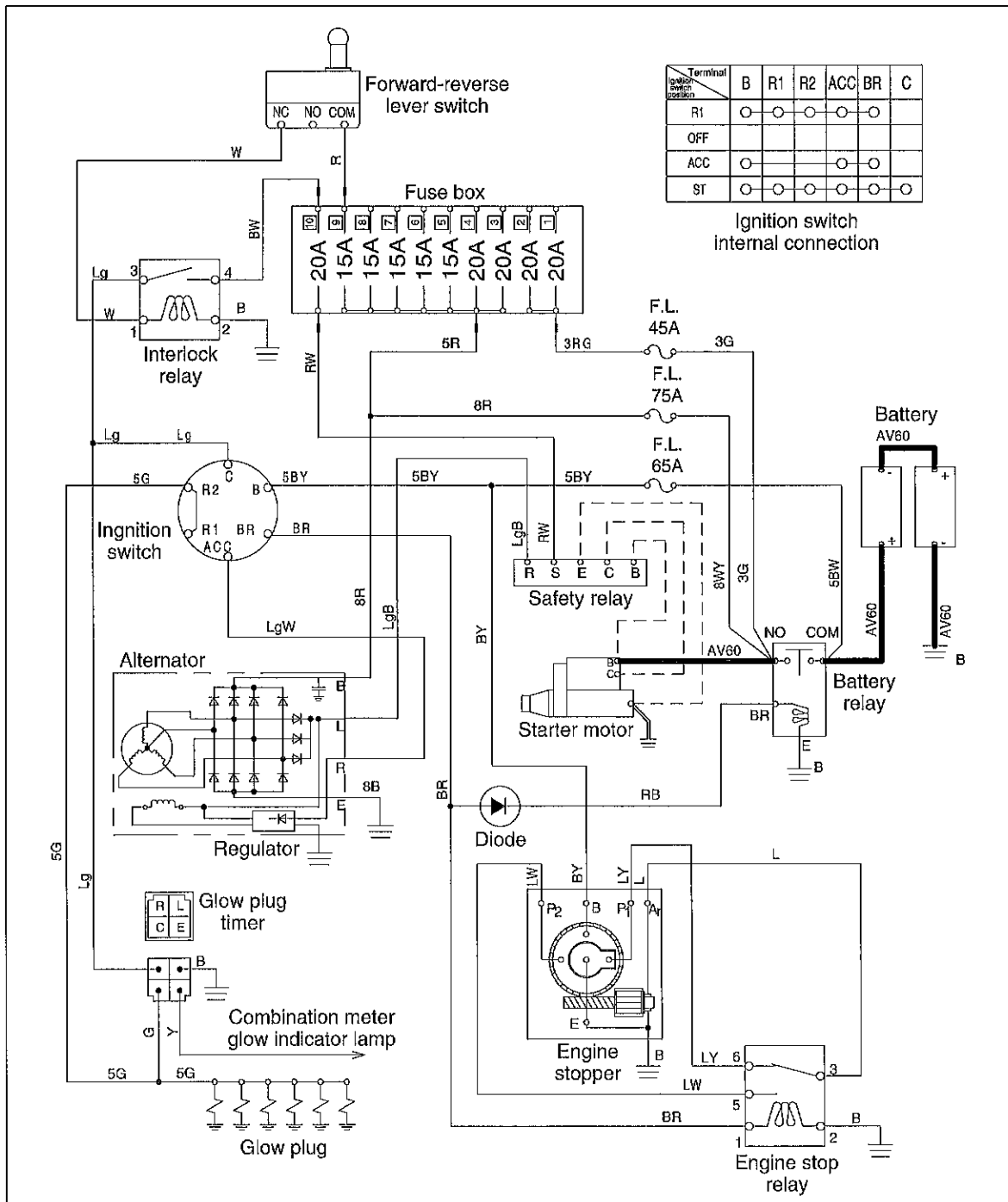

2-2. Engine

Check the following items before troubleshooting.

- Forward/reverse lever is in "neutral" position.
- No fuse blew.

2-2-1. Engine Will Not Start (Starter Motor Does Not Run)

Reference Fig. : 2-2

| Check point | Check/Cause | Action |
|--|---|---|
| 1. Battery Capacity | - Measure battery voltage or specific gravity. Standard voltage: 24V or more Standard specific gravity: 1.26V or more - If the measured value is below the standard one, the battery is weak. | Charge or replace the battery. |
| 2. Ignition Switch | - Check continuity between ○ and ○ according to ignition switch connection table. The switch is OK if there is continuity between the connections ○ - ○ of all switch positions. - If continuity is abnormal, the ignition switch is faulty. | Replace the ignition switch. |
| 3. Starter Motor | (1) When starting ignition switch, measure voltage between starter motor pin B and chassis ground. Standard voltage: 24V or more (2) When starting ignition switch, measure voltage between starter motor pin C and chassis ground. Standard voltage: 24V or more - If the starter motor does not run even though above items (1) and (2) are OK, the motor is faulty. | Replace the starter motor. |
| 4. Safety Relay | (1) When starting ignition switch, measure voltage between safety relay pin S and chassis ground. Standard voltage: 24V or more (2) When starting ignition switch, measure voltage between safety relay pin B and chassis ground. Standard voltage: 24V or more (3) When starting ignition switch, measure voltage between safety relay pin C and chassis ground. Standard voltage: 24V or more - If above item (1) and (2) are OK and item (3) is NG, the safety relay switch is faulty. | Replace the safety relay. |
| 5. Battery Relay | (1) When turning ignition switch OFF, measure voltage between battery relay primary terminal and chassis ground. Standard voltage: 24V or more (2) When turning ignition switch ON, measure voltage between battery relay RB wire terminal and chassis ground. Standard voltage: 24V or more - If above items (1) and (2) are OK and the battery relay switching click does not sound when the ignition switch is turned ON, the battery relay is faulty. | Replace the battery relay. |
| 6. Forward/Reverse Lever Switch (Neutral Start Switch) | - Check continuity between forward/reverse lever switch COM terminal and NC terminal with forward/reverse lever in neutral and with ignition switch OFF. - Continuity present indicates normal condition. If there is no continuity, the forward/reverse lever switch is faulty. | Replace the forward/reverse lever switch. |

FAULT DIAGNOSIS OF ELECTRICAL SYSTEM

Fig. : 2-2

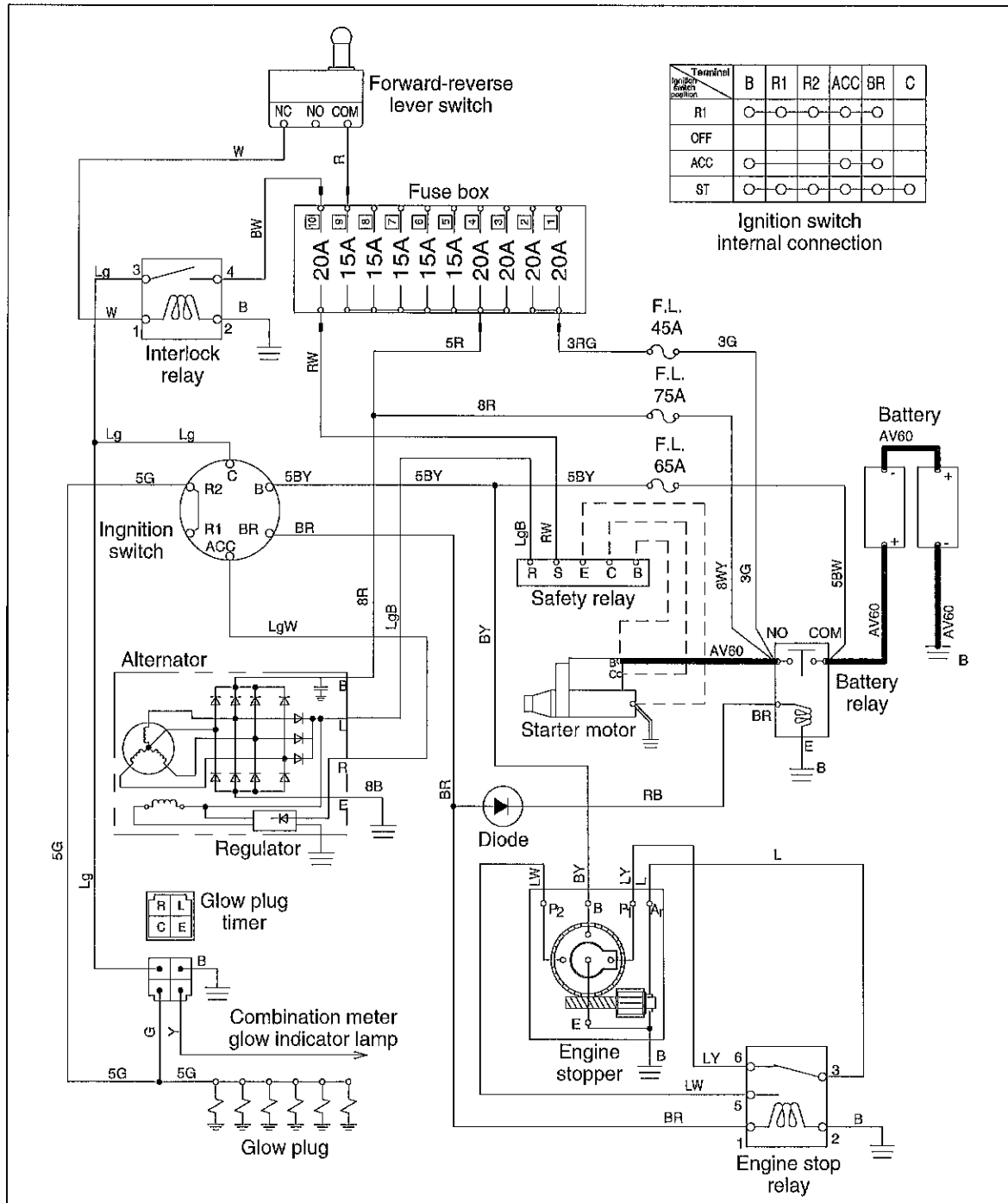

FAULT DIAGNOSIS OF ELECTRICAL SYSTEM

2-2-1. Engine Will Not Start (Starter Motor Does Not Run)

Reference Fig. : 2-2

| Check point | Check/Cause | Action |
|---|--|--------------------------------|
| 7. Interlock Relay | (1) Measure the voltage between the interlock relay pin 1 inlet W wire and chassis ground. Standard voltage: 24V or more (2) Measure the voltage between the interlock relay pin 3 inlet Lg wire and chassis ground. Standard voltage: 24V or more - If above items (1) and (2) are OK and electricity does not flow through interlock relay pin 4, the interlock relay is faulty. | Replace the interlock relay. |
| 8. Harness Connecting Between Terminals | - Check harness between terminals for continuity. - No continuity indicates that harness is open or poorly connected. | Repair or replace the harness. |

2-2-2. Engine Will Not Start (But Starter Motor Runs)

- Check that fuel is being supplied to the injection pump inlet.

Reference Fig. : 2-2

| Check point | Check/Cause | Action |
|---|---|--------------------------------|
| 1. Engine Stopper | (1) When turning ignition switch ON, measure voltage between engine stopper pin B and chassis ground. Standard voltage: 24V or more (2) When turning ignition switch ON, measure voltage between engine stopper pin P2 and chassis ground. It is normal that no electricity flows. - If above item (1) is OK and electricity is flowing in (2), then the engine stopper is faulty. | Replace the engine stopper. |
| 2. Engine Stop relay | (1) When turning ignition switch ON, measure voltage between engine stop relay pin 1 and chassis ground. Standard voltage: 24V or more (2) When turning ignition switch ON, measure voltage between engine stop relay pin 5 and chassis ground. Standard voltage: 24V or more - If above items (1) and (2) are OK and electricity does not flow through engine stopper relay pin 3, the engine stopper relay is faulty. | Replace the engine stop relay. |
| 3. Harness Connecting Between Terminals | - Check harness between terminals for continuity. - No continuity indicates that harness is open or poorly connected. | Repair or replace the harness. |

2-2-3. Engine Does Not Stop Running

Reference Fig. : 2-2

| Check point | Check/Cause | Action |
|-------------------|--|-----------------------------|
| 1. Engine Stopper | (1) When turning ignition switch OFF, measure voltage between engine stopper pin B and chassis ground. Standard voltage: 24V or more (2) When turning ignition switch OFF, measure voltage between engine stopper pin P2 and chassis ground. Standard voltage: 24V or more - If above item (1) is OK and item (2) is NG, the engine stopper is faulty. | Replace the engine stopper. |

FAULT DIAGNOSIS OF ELECTRICAL SYSTEM

Fig. : 2-2

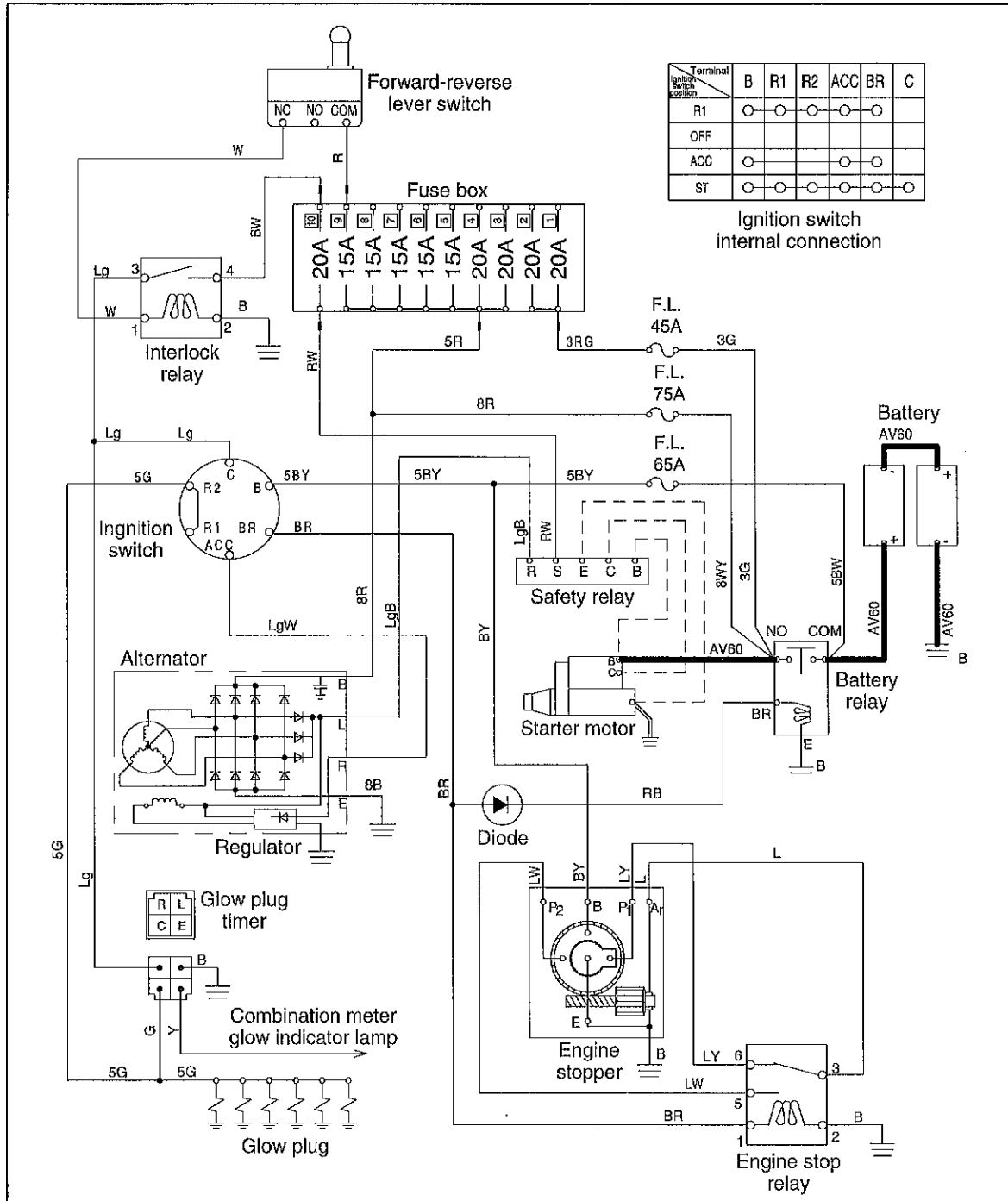

FAULT DIAGNOSIS OF ELECTRICAL SYSTEM

2-2-4. No Charging

Reference Fig. : 2-2

| Check point | Check/Cause | Action |
|---------------|--|--|
| 1. Alternator | <p>(1) When the ignition switch is ON, measure voltage between alternator pin B and chassis ground. Standard voltage: At least the intermediate engine speed, or 27V or more</p> <p>(2) When the ignition switch is ON, the measured voltage between alternator pin R and chassis ground must be 27V or higher.</p> <ul style="list-style-type: none"> - If above item (1) is NG, the alternator is faulty. - If above item (1) is OK and item (2) is NG, the regulator is faulty. - If battery is not charged even though above items (1) and (2) are OK, the battery is faulty. | <p>Replace the alternator.</p> <p>Replace the regulator.</p> <p>Replace the battery.</p> |

2-2-5. Glow Plug Is Not Heated (Engine Starting Performance Is Bad)

Reference Fig. : 2-2

| Check point | Check/Cause | Action |
|---|---|---------------------------------------|
| 1. Glow Plug | <ul style="list-style-type: none"> - When heating (preheating) ignition switch, measure voltage between glow plug inlet G wire and chassis ground. Standard voltage: 24V or more - If measurement is within the standard range, the glow plug is faulty. | <p>Replace the glow plug.</p> |
| 2. Glow Plug Timer | <p>(1) Set the ignition switch to HEART (preheat), then immediately turn it to ON and measure the voltage between the glow plug timer pin L and chassis ground at that time. Standard voltage: 24V or more</p> <p>(2) Set the ignition switch to HEAT (preheat), then immediately turn it to ON and measure the voltage between the glow plug timer pin R and chassis ground at that time. (The current flows for a fixed length of time.) Standard voltage: 24V or more</p> <ul style="list-style-type: none"> - If above item (1) is OK and item (2) is NG, the glow plug timer is faulty. | <p>Replace the glow plug timer.</p> |
| 3. Harness Connecting Between Terminals | <ul style="list-style-type: none"> - Check harness between terminals for continuity. - No continuity indicates that harness is open or poorly connected. | <p>Repair or replace the harness.</p> |

2-2-6. Starter Motor Runs Even Without Forward/Reverse Lever In Neutral

Reference Fig. : 2-2

| Check point | Check/Cause | Action |
|--|---|--|
| 1. Forward/Reverse Lever Switch (Neutral Start Switch) | <p>(1) When turning forward/reverse lever to forward with ignition switch OFF, check continuity between forward/reverse lever switch COM terminal and NC terminal.</p> <p>(2) When turning forward/reverse lever to reverse with ignition switch OFF, check continuity between forward/reverse lever switch COM terminal and NC terminal.</p> <ul style="list-style-type: none"> - No continuity indicates normal condition. If any continuity is present, the forward/reverse lever switch is faulty. | <p>Replace the forward/reverse lever switch.</p> |

Fig. : 2-3

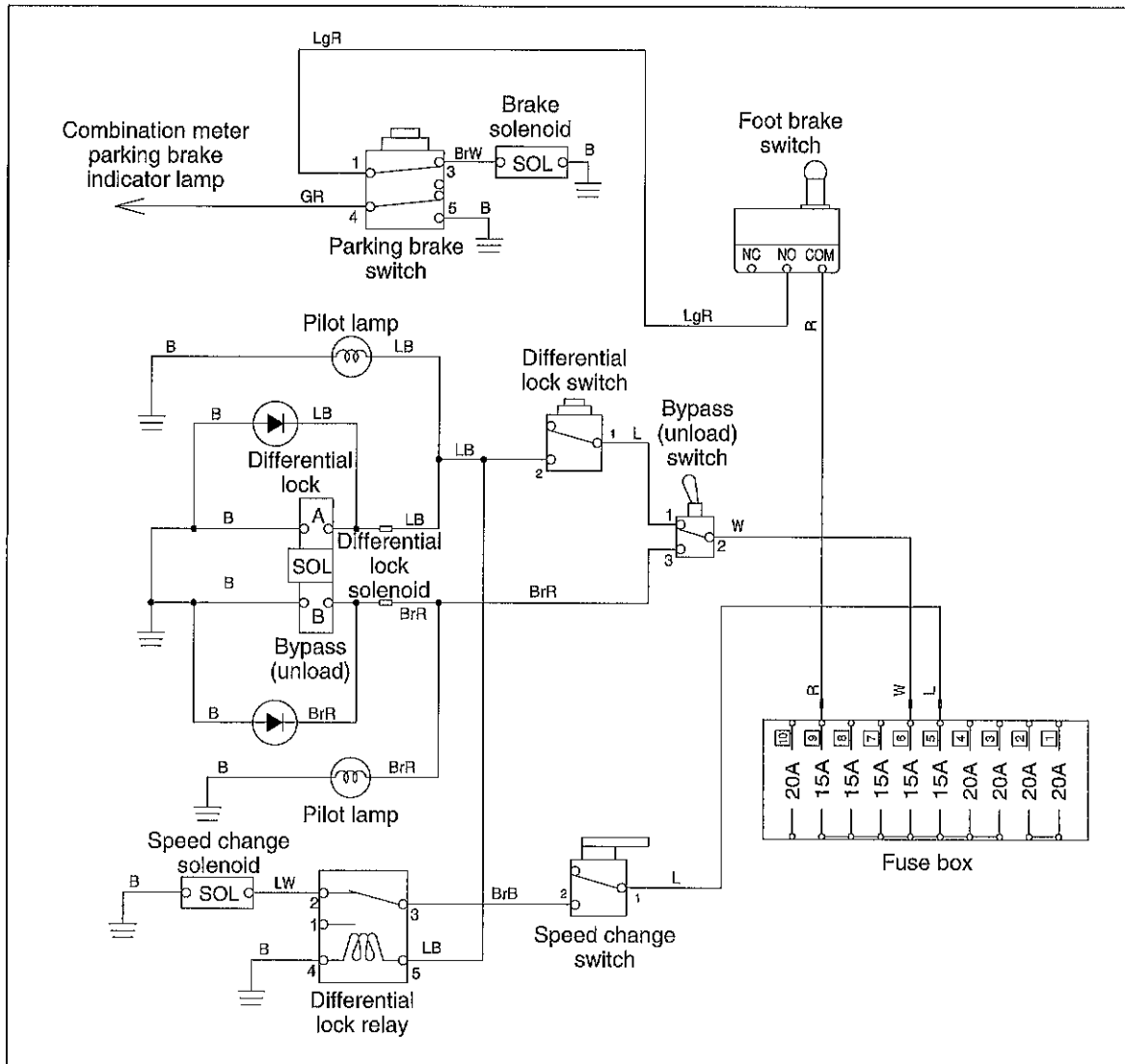

2-3. Propulsion

Check the following items before troubleshooting.

- No fuse blew.

2-3-1. Vehicle Moves Neither Forward Nor Backward

- Parking brake switch is turned OFF.
- Foot brake switch is turned OFF.

Reference Fig. : 2-3

| Check point | Check/Cause | Action |
|---------------------------|---|--------------------------------------|
| 1. Bypass (Unload) Switch | - Verify that the bypass (unload) switch is in the OFF position. - If the bypass (unload) switch is ON, the vehicle will not move. | Turn the bypass (unload) switch OFF. |

2-3-2. Differential Lock Does Not Function

Reference Fig. : 2-3

| Check point | Check/Cause | Action |
|---|---|---|
| 1. Differential Lock Solenoid | - Disconnect harness and measure resistance of coil. Standard resistance: 15 Ω - If the measured resistance is NG, the differential lock solenoid is faulty. | Replace the differential lock solenoid. |
| 2. Differential Lock Switch | (1) When the differential lock switch is ON, measure the voltage between differential lock switch pin 1 inlet L wire and chassis ground. Standard voltage: 24V or more (2) When turning ignition switch ON, measure voltage between parking brake switch pin 2 inlet L wire and chassis ground. Standard voltage: 24V or more - If above item (1) is OK and item (2) is NG, the differential lock switch is faulty. | Replace the differential lock switch. |
| 3. Harness Connecting Between Terminals | - Check harness between terminals for continuity. - No continuity indicates that harness is open or poorly connected. | Repair or replace the harness. |

2-3-3. Dragging Of The Roll Occurs During Driving When The Differential Is Locked

Reference Fig. : 2-3

| Check point | Check/Cause | Action |
|--------------------------|--|--|
| 1. Speed change Solenoid | - When the differential switch is ON, measure the voltage between speed change solenoid pin inlet LW wire and chassis ground. It is normal that no electricity flows. - If electricity is flowing, then the differential lock relay is faulty or else there is an open circuit at the differential lock relay pin 5 inlet harness LB wire. | Repair or replace the differential lock harness. |

Fig. : 2-3

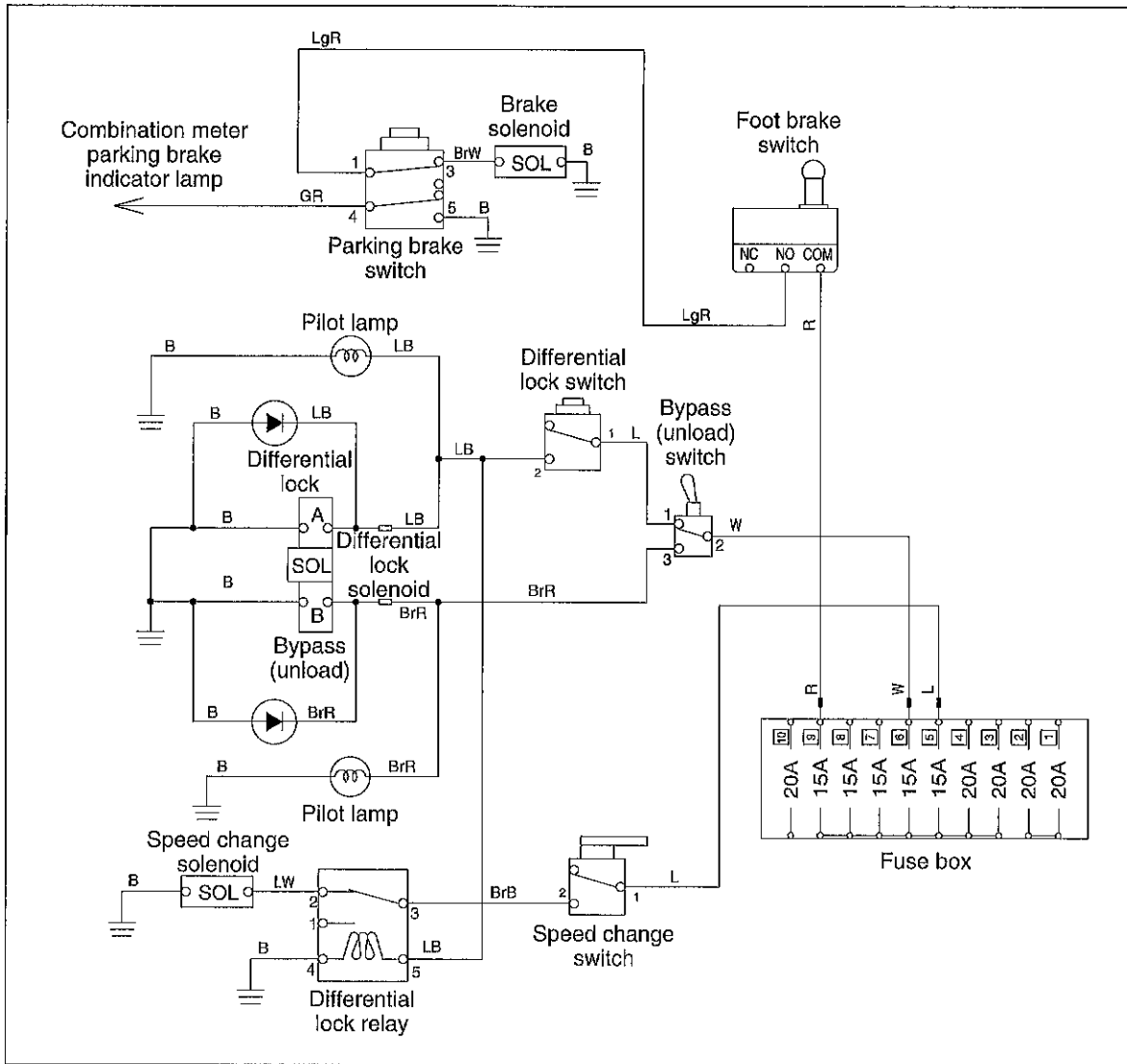

2-3-4. Vehicle Speed (Gear) Does Not Change

- Differential lock switch must be turned OFF.

Reference Fig. : 2-3

| Check point | Check/Cause | Action |
|---|---|--------------------------------------|
| 1. Speed change Solenoid | - Disconnect harness and measure resistance of coil. Standard resistance: 20 Ω - If the measured resistance is NG, the transmission solenoid is faulty. | Replace the transmission solenoid. |
| 2. Differential Lock Relay | (1) When the speed change switch is ON, measure the voltage between differential lock relay pin 3 inlet BrB wire and chassis ground. Standard voltage: 24V or more (2) When the speed change switch is ON, measure the voltage between differential lock relay pin 2 inlet LW wire and chassis ground. Standard voltage: 24V or more - If above item (1) is OK and item (2) is NG, the differential lock relay is faulty. | Replace the differential lock relay. |
| 3. Speed change Switch | (1) When the speed change switch is ON, measure the voltage between speed change switch pin 1 inlet L wire and chassis ground. Standard voltage: 24V or more (2) When the speed change switch is ON, measure the voltage between speed change switch pin 2 inlet BrB wire and chassis ground. Standard voltage: 24V or more - If above item (1) is OK and item (2) is NG, the speed change switch is faulty. | Replace the speed change switch. |
| 4. Harness Connecting Between Terminals | - Check harness between terminals for continuity. - No continuity indicates that harness is open or poorly connected. | Repair or replace the harness. |

Fig. : 2-3

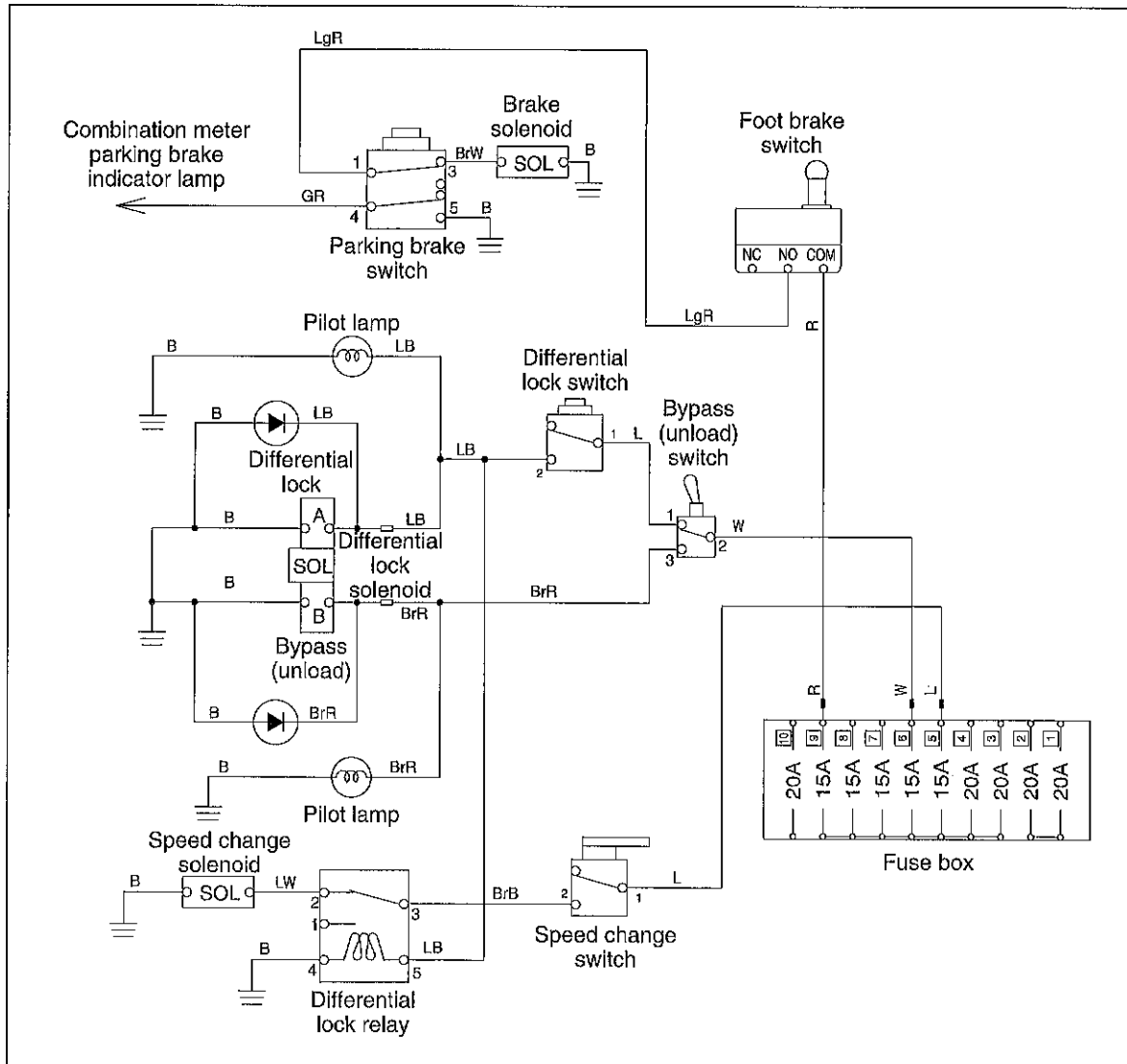

2-3-5. Brake Does Not Release

- The parking brake switch must be OFF.
- The foot brake switch must be ON (the brake pedal is not depressed).

Reference Fig. : 2-3

| Check point | Check/Cause | Action |
|---|---|-----------------------------------|
| 1. Brake Solenoid | - Disconnect harness and measure resistance of coil. Standard resistance: 44 Ω - If measured resistance is abnormal, the brake solenoid is faulty. | Replace the brake solenoid. |
| 2. Parking Brake Switch | (1) When the ignition switch is ON, measure voltage between parking brake switch pin 3 inlet BrW wire and chassis ground. Standard voltage: 24V or more (2) When the ignition switch is ON, measure voltage between parking brake switch pin 1 inlet LgR wire and chassis ground. Standard voltage: 24V or more - If above item (2) is OK and item (1) is NG, the parking brake switch is faulty. | Replace the parking brake switch. |
| 3. Foot Brake Switch | (1) When turning ignition switch ON, measure voltage between foot brake switch COM terminal inlet R wire and chassis ground. Standard voltage: 24V or more (2) When turning ignition switch ON, measure voltage between foot brake switch NO terminal inlet LgR wire and chassis ground. Standard voltage: 24V or more - If above item (1) is OK and item (2) is NG, the foot brake switch is faulty. | Replace the foot brake switch. |
| 4. Harness Connecting Between Terminals | - Check harness between terminals for continuity. - No continuity indicates that harness is open or poorly connected. | Repair or replace the harness. |

2-3-6. Brake Does Not Operate

- When the parking brake switch is ON or the foot brake switch is OFF (the brake pedal is depressed)

Reference Fig. : 2-3

| Check point | Check/Cause | Action |
|-------------------------|--|-----------------------------------|
| 1. Brake Solenoid | - Disconnect harness and measure resistance of coil. Standard resistance: 44 Ω - If measured resistance is abnormal, the brake solenoid is faulty. | Replace the brake solenoid. |
| 2. Parking Brake switch | -When turning parking brake switch ON with ignition switch ON, measure voltage between parking brake switch pin 3 inlet BrW wire and chassis ground. It is normal that no electricity flows. - If electricity flows, the parking brake switch is faulty. | Replace the parking brake switch. |
| 3. Foot Brake Switch | - When turning foot brake switch ON with ignition switch OFF, measure voltage between foot brake switch NO terminal inlet LgR wire and chassis ground. It is normal that no electricity flows. - If electricity flows, the foot brake switch is faulty. | Replace the foot brake switch. |

FAULT DIAGNOSIS OF ELECTRICAL SYSTEM

Fig. : 2-4

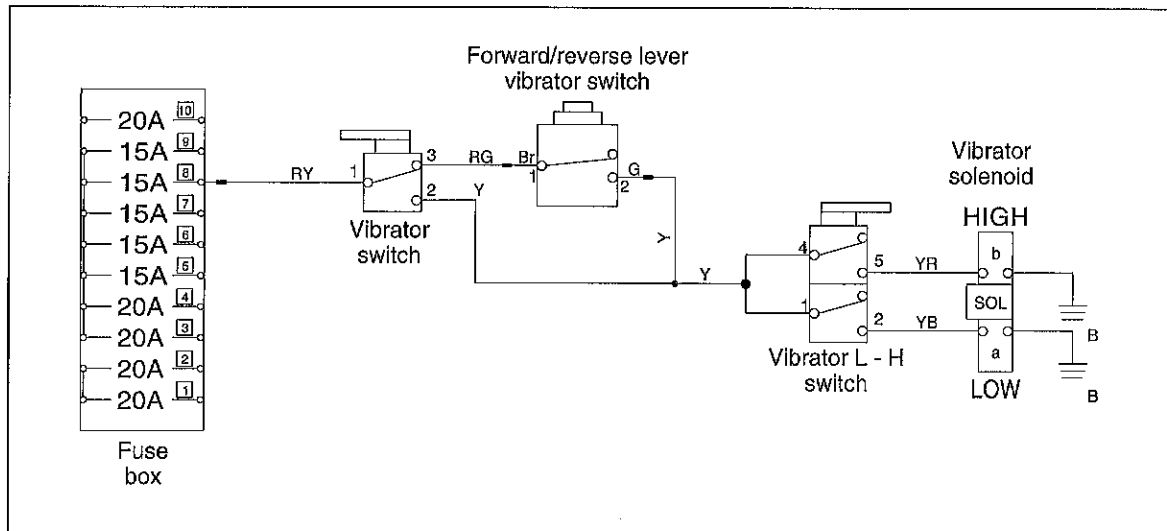

2-4. Vibrator

Check the following items before troubleshooting.

- No fuse blew.

2-4-1. No Vibration Occurs

- The vibrator L-H switch on the control panel must not be turned OFF.

Reference Fig. : 2-4

| Check point | Check/Cause | Action |
|---|---|----------------------------------|
| 1. Vibrator Solenoid | - Disconnect the harness of the a or b vibrator solenoid and measure the coil resistance. Standard resistance: XXX Ω - If measured resistance is abnormal, the vibrator solenoid is faulty. | Replace the vibrator solenoid. |
| 2. Vibrator L-H switch | (1) When the ignition switch is ON, measure the voltage between vibrator L-H switch pin 1 or pin 4 inlet Y wire and chassis ground. Standard voltage: 24V (2) When the ignition switch is ON, measure the voltage between vibrator L-H switch pin 2 inlet YB wire or pin 5 inlet YR wire and chassis ground. Standard voltage: 24V - If above item (1) is OK and item (2) is NG, the vibrator L-H switch is faulty. | Replace the vibrator L-H switch. |
| 3. Harness Connecting Between Terminals | - Check harness between terminals for continuity. - No continuity indicates that harness is open or poorly connected. | Repair or replace the harness. |

2-4-2. Amplitude Does Not Change (Remains Either Low or High)

- The vibrator L-H switch on the control panel must not be turned OFF.

Reference Fig. : 2-4

| Check point | Check/Cause | Action |
|---|--|----------------------------------|
| 1. Vibrator Solenoid | - Disconnect the harness of the a or b vibrator solenoid and measure the coil resistance. Standard resistance: XXX Ω - If measured resistance is abnormal, the vibrator solenoid is faulty. | Replace the vibrator solenoid. |
| 2. Vibrator L-H Switch | (1) When the ignition switch is ON, measure the voltage between vibrator L-H switch pin 1 or pin 4 inlet Y wire and chassis ground. Standard voltage: 24V (2) When the ignition switch is ON, measure the voltage between vibrator L-H switch pin 2 inlet YB wire or pin 5 inlet YR wire and chassis ground when the vibrator L-H switch is set to Low or High. Standard voltage: 24V - If above item (1) is OK and item (2) is NG, the vibrator L-H switch is faulty. | Replace the vibrator L-H switch. |
| 3. Harness Connecting Between Terminals | - Check harness between terminals for continuity. - No continuity indicates that harness is open or poorly connected. | Repair or replace the harness. |

FAULT DIAGNOSIS OF ELECTRICAL SYSTEM

Fig. : 2-4

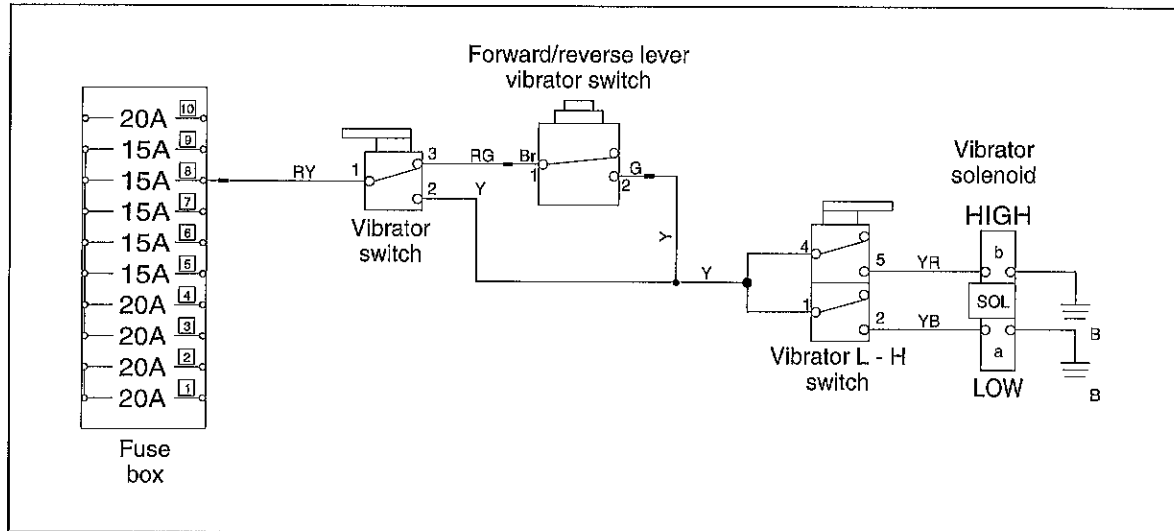

2-4-3. Vibrator Control Is Continuously Engaged Or Does Not Change When The Forward/Reverse Lever Is Operated

- The vibrator L-H switch on the control panel must not be turned OFF.

Reference Fig. : 2-4

| Check point | Check/Cause | Action |
|--|---|---|
| 1. Vibrator Switch | <ul style="list-style-type: none"> - When turning ignition switch ON, measure voltage between vibrator switch pins 1 inlet RY wire and chassis ground. Standard voltage: 24V - If the above is OK, and no electricity flows to the pin 2 inlet Y wire or pin 3 inlet RG wire when the vibrator switch position is changed, then the vibrator switch is faulty. | Replace the vibrator switch. |
| 2. Forward/Reverse Lever Switch (Neutral Start Switch) | <ul style="list-style-type: none"> - When the ignition switch is ON, measure the voltage between forward/reverse lever switch pin 1 inlet Br wire and chassis ground. Standard voltage: 24V - If the above is OK and no electricity flows to the forward/reverse lever switch pin 2 inlet G wire when the forward/reverse lever switch is ON, the forward/reverse lever switch is faulty. | Replace the forward/reverse lever switch. |

FAULT DIAGNOSIS OF ELECTRICAL SYSTEM

Fig. : 2-5

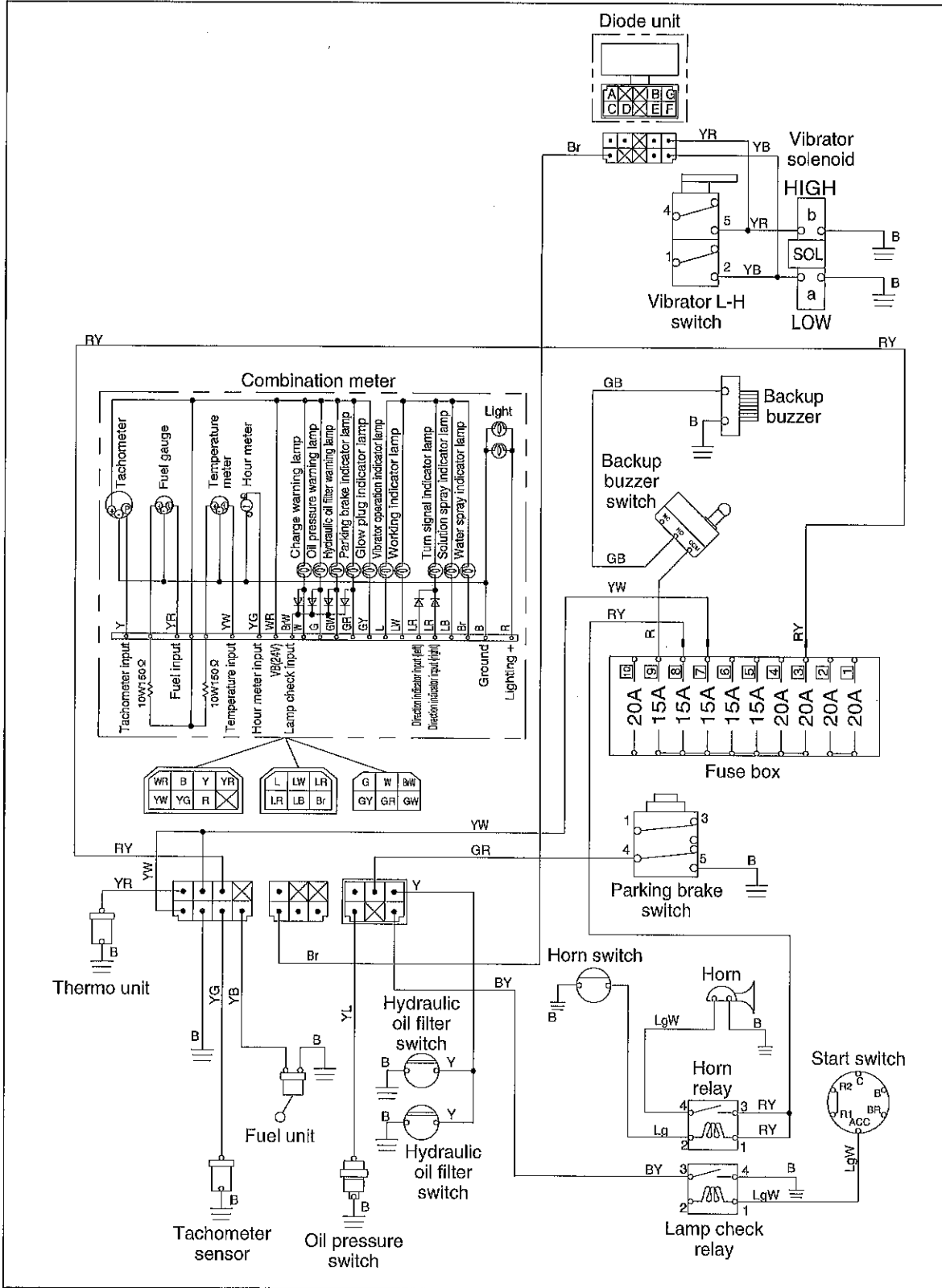

9-022

2-5. Lighting and accessories

Check the following items before troubleshooting.

- No fuse blew.

2-5-1. Combination Meter Monitor Lamps Do Not Light

Reference Fig. : 2-5

| Check point | Check/Cause | Action |
|---|--|--------------------------------|
| 1. Each Bulb | <ul style="list-style-type: none"> - Check that none of the combination meter bulbs is burned out or has a contact failure (oil pressure warning lamp, hydraulic oil filter warning lamp, glow plug indicator lamp, parking brake indicator lamp and vibrator operation indicator lamp). - Bulb is faulty or poorly connected. | Replace each bulb. |
| 2. Lamp Check Relay | <ul style="list-style-type: none"> (1) When turning ignition switch ON, measure voltage between lamp check relay pin 1 inlet LgW wire and chassis ground. Standard voltage: 24V or more (2) When turning ignition switch ON, measure voltage between lamp check relay pin 3 inlet BY wire and chassis ground. (3) When turning ignition switch ON, measure voltage between lamp check relay pin 4 and chassis ground. Standard voltage: 24V or more - If the warning lamp does not light when above items (1) and (2) are OK and item (3) is NG, the lamp check relay is faulty. | Replace the lamp check relay. |
| 3. Harness Connecting Between Terminals | <ul style="list-style-type: none"> - Check harness between terminals for continuity. - No continuity indicates that harness is open or poorly connected. | Repair or replace the harness. |

2-5-2. Tachometer Reading Is Abnormal

- The other lamps light correctly.

Reference Fig. : 2-5

| Check point | Check/Cause | Action |
|---|---|--------------------------------|
| 1. Tachometer Sensor | <ul style="list-style-type: none"> - Start the engine and fix the engine speed at 1000 rpm. Connect a digital multimeter between the tachometer sensor pin YG wire and ground wire and measure the pulse count for 1 minute. Standard pulse count: 2000 - If the standard pulse count is NG, the tachometer sensor is faulty. | Replace the tachometer sensor. |
| 2. Tachometer | <ul style="list-style-type: none"> - When turning ignition switch ON, measure voltage between tachometer plus (+) terminal WR wire and chassis ground. Standard voltage: 24V or more - If the above is OK, and there is no problem with the tachometer sensor, then the tachometer is faulty. | Replace the combination meter. |
| 3. Harness Connecting Between Terminals | <ul style="list-style-type: none"> - Check harness between terminals for continuity. - No continuity indicates that harness is open or poorly connected. | Repair or replace the harness. |

FAULT DIAGNOSIS OF ELECTRICAL SYSTEM

Fig. : 2-5

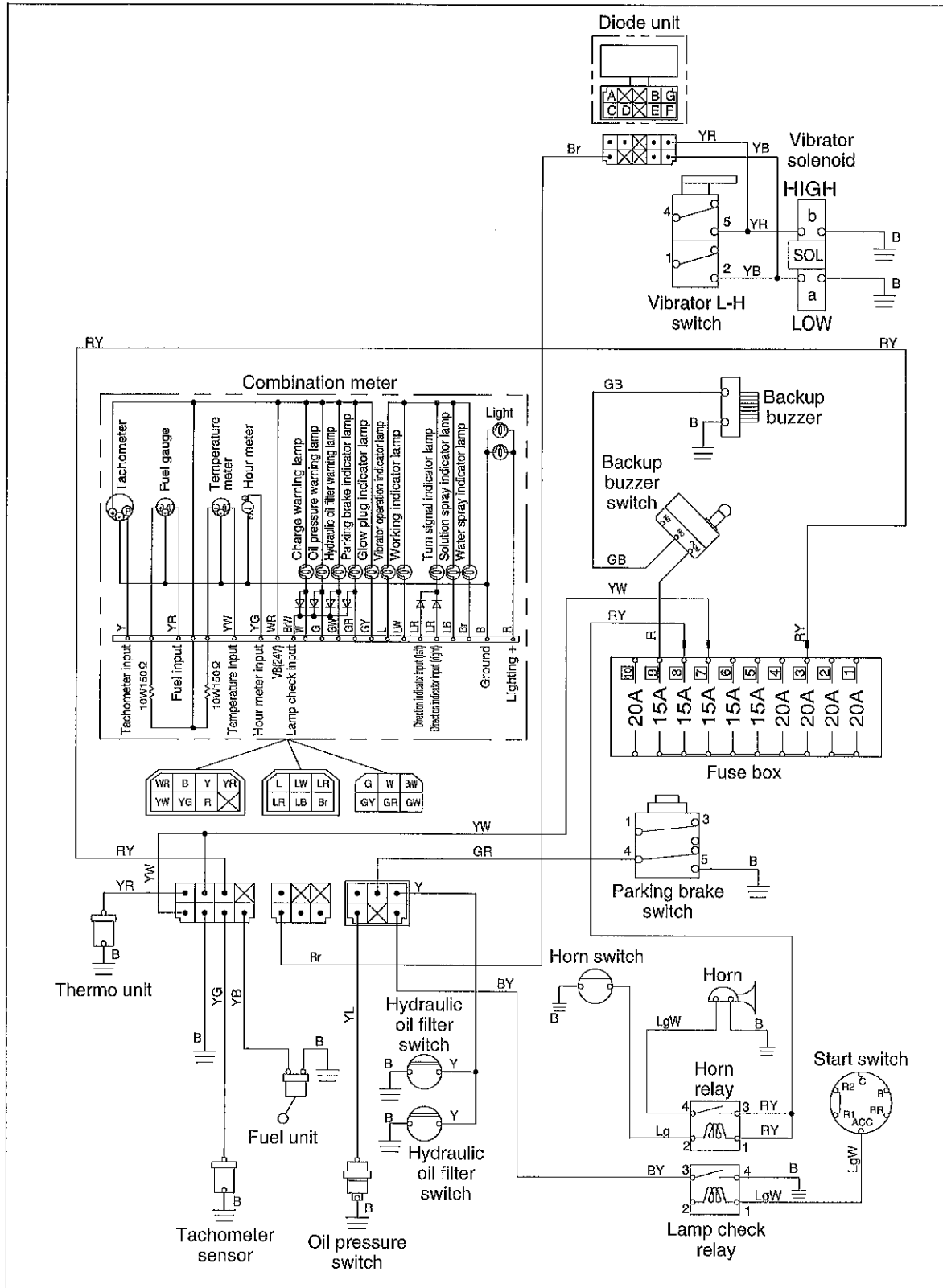

9-024

2-5-3. Hour Meter Is Abnormal

- The other lamps light correctly.

Reference Fig. : 2-5

| Check point | Check/Cause | Action |
|---|--|--------------------------------|
| 1. Hour Meter | - When turning ignition switch ON, measure voltage between hour meter plus (+) terminal YG wire and chassis ground. Standard voltage: 24V or more - If above measurement is normal, the hour meter is faulty.. | Replace the combination meter. |
| 2. Harness Connecting Between Terminals | - Check harness between terminals for continuity. - No continuity indicates that harness is open or poorly connected. | Repair or replace the harness. |

2-5-4. Temperature Gauge Is Abnormal

- The other lamps light correctly.

Reference Fig. : 2-5

| Check point | Check/Cause | Action |
|---|--|--------------------------------|
| 1. Thermo-unit | - Disconnect harness and measure resistance of thermo-unit. Standard resistance: 153.9 Ω (when unit temperature is 50°C, 122°F) 24.9 Ω (when unit temperature is 103°C, 217°F) - If measured resistance is abnormal, the thermo-unit is faulty. | Replace the thermo-unit. |
| 2. Temperature Gauge | - When turning ignition switch ON, measure voltage between temperature gauge plus (+) terminal WR wire and chassis ground. Standard voltage: 24V or more - If the above is OK, and there is no problem with the thermo unit, then the thermometer is faulty. | Replace the combination meter. |
| 3. Harness Connecting Between Terminals | - Check harness between terminals for continuity. - No continuity indicates that harness is open or poorly connected. | Repair or replace the harness. |

2-5-5. Fuel Gauge Is Abnormal

- The other lamps light correctly.

Reference Fig. : 2-5

| Check point | Check/Cause | Action |
|---|--|--------------------------------|
| 1. Fuel-unit | - Disconnect harness and measure resistance of fuel-unit. 10 Ω (when float is at FULL position) 90 Ω (when float is at EMPTY position) | Replace the fuel-unit |
| 2. Fuel Gauge | - If measured resistance is abnormal, the fuel-unit is faulty. - When turning ignition switch ON, measure voltage between fuel gauge plus (+) terminal WR wire and chassis ground. Standard voltage: 24V or more - If the above is OK, and there is no problem with the fuel unit, then the fuel gauge is faulty. | Replace the combination meter. |
| 3. Harness Connecting Between Terminals | - Check harness between terminals for continuity. - No continuity indicates that harness is open or poorly connected. | Repair or replace the harness. |

FAULT DIAGNOSIS OF ELECTRICAL SYSTEM

Fig. : 2-5

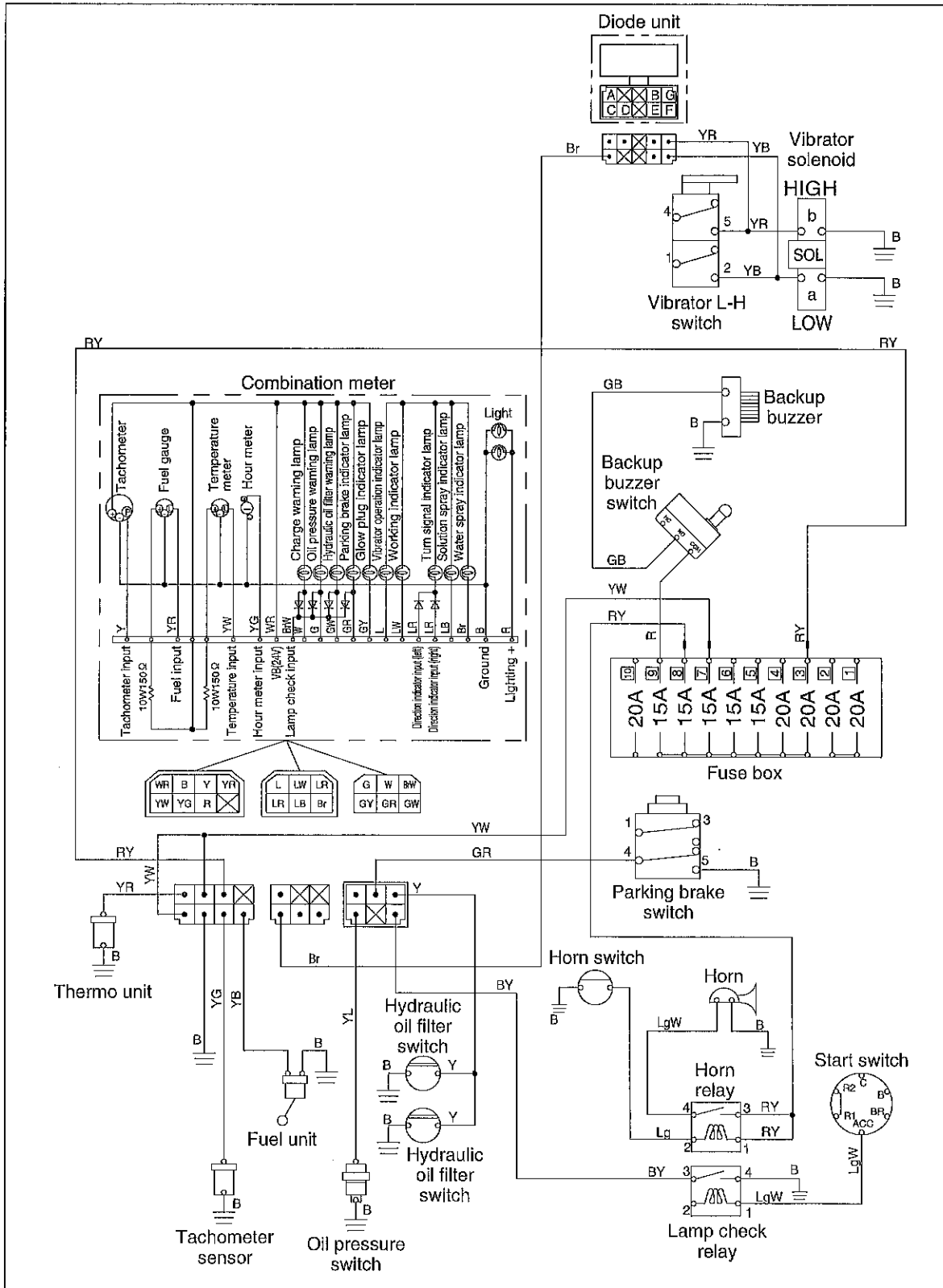

9-026

2-5-6. Hydraulic Oil Filter Warning Lamp Remains ON

- Check without starting the engine.

Reference Fig. : 2-5

| Check point | Check/Cause | Action |
|--------------------------------|---|--|
| 1. Hydraulic Oil Filter Switch | - Turn the ignition switch ON and check continuity between the hydraulic oil filter switch inlet terminal and chassis ground. - No continuity indicates normal condition. If any continuity is present, the hydraulic oil filter switch is faulty. | Replace the hydraulic oil filter switch. |

2-5-7. Oil Pressure Warning Lamp Remains ON

- Check without starting the engine.

Reference Fig. : 2-5

| Check point | Check/Cause | Action |
|------------------------|---|----------------------------------|
| 1. Oil Pressure Switch | - Turn the ignition switch ON and check continuity between the oil pressure switch inlet terminal and chassis ground. - No continuity indicates normal condition. If any continuity is present, the oil pressure switch is faulty. | Replace the oil pressure switch. |

2-5-8. Vibrator Operation Indicator Lamp Does Not Turn ON

Reference Fig. : 2-5

| Check point | Check/Cause | Action |
|---|--|--------------------------------|
| 1. Bulb | - Check if bulb has burnt out or is poorly connected. - Bulb is faulty or poorly connected. | Replace the bulb. |
| 2. Diode unit | (1) Measure the voltage between diode the unit pin F inlet YR wire or pin G inlet YB wire and chassis ground. Standard voltage: 24V or more (2) Measure the voltage between the diode unit pin A inlet Br wire and chassis ground. Standard voltage: 24V or more - If above item (1) is OK and item (2) is NG, the diode unit is faulty. | Replace the diode unit. |
| 3. Harness Connecting Between Terminals | - Check harness between terminals for continuity. - No continuity indicates that harness is open or poorly connected. | Repair or replace the harness. |

FAULT DIAGNOSIS OF ELECTRICAL SYSTEM

Fig. : 2-5

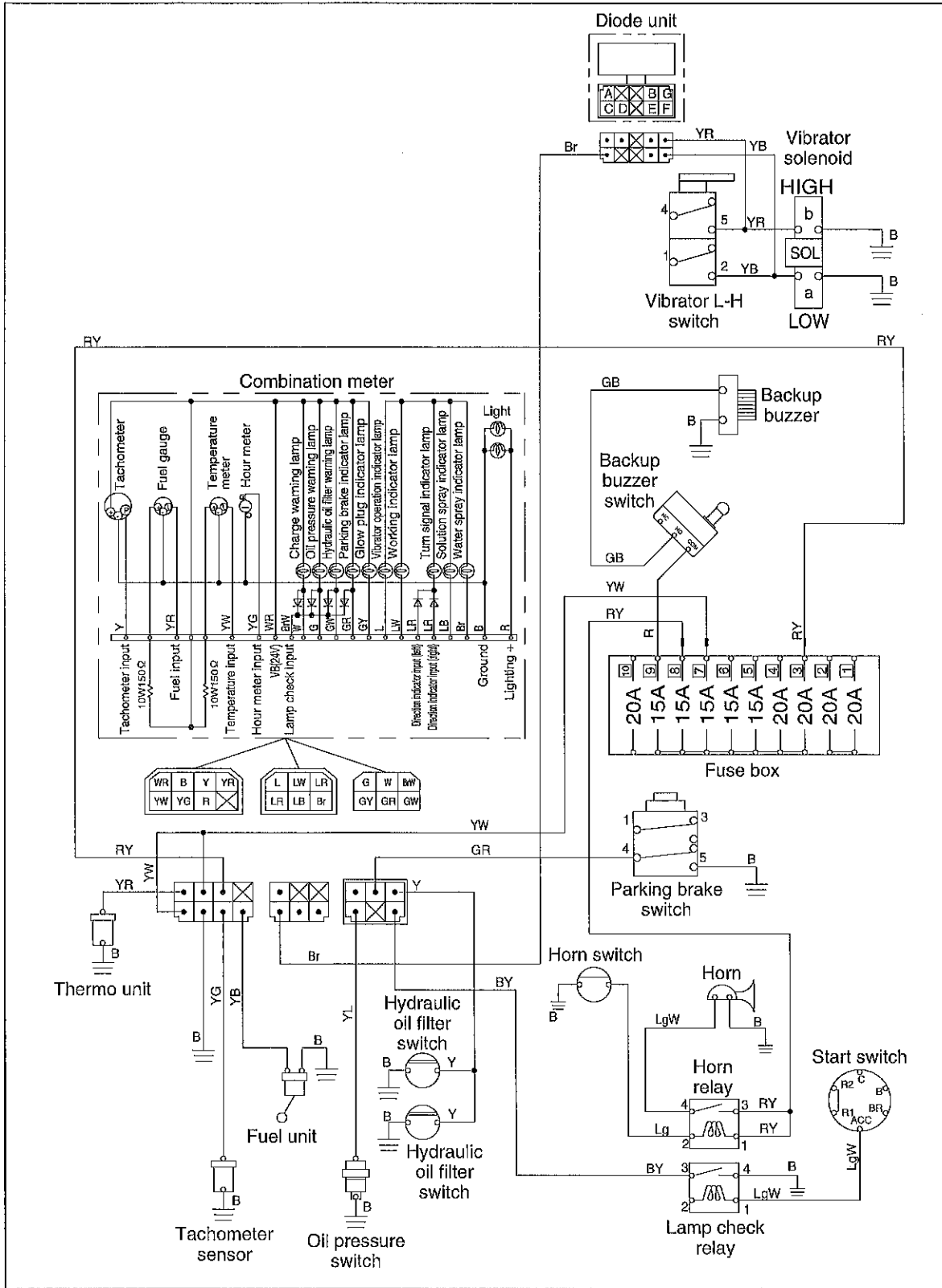

9-028

2-5-9. Parking Brake Indicator Lamp Does Not Light

Reference Fig. : 2-5

| Check point | Check/Cause | Action |
|---|--|-----------------------------------|
| 1. Bulb | - Check if bulb has burnt out or is poorly connected. - Bulb is faulty or poorly connected. | Replace the bulb. |
| 2. Parking Brake Switch | - When turning ignition switch ON, measure voltage between parking brake switch pin 4 inlet GR wire and chassis ground. Standard voltage: 24V or more - If the above item is OK and the parking brake lamp does not light even though the parking brake switch is turned ON/OFF, the parking brake switch is faulty. | Replace the parking brake switch. |
| 3. Harness Connecting Between Terminals | - Check harness between terminals for continuity. - No continuity indicates that harness is open or poorly connected. | Repair or replace the harness. |

2-5-10. Horn Does Not Sound

Reference Fig. : 2-5

| Check point | Check/Cause | Action |
|---|--|--------------------------------|
| 1. Horn | - Disconnect horn and connect the horn terminal to the battery directly. - If the horn does not sound, it is faulty. | Replace the horn. |
| 2. Horn Relay | (1) When pressing horn switch with ignition switch ON, measure voltage between horn relay pin 1 RY wire and chassis ground. Standard voltage: 24V or more (2) When pressing horn switch with ignition switch ON, measure voltage between horn relay pin 4 LgW wire and chassis ground. Standard voltage: 24V or more - If above item (1) is OK and item (2) is NG, the horn relay is faulty. | Replace the horn relay. |
| 3. Horn Switch (push button) | - When horn switch is pushed ON and OFF, check if continuity between switch terminals changes between presence and absence. - If continuity between switch terminals does not change between presence and absence, the horn switch is defective. | Replace the horn switch. |
| 4. Harness Connecting Between Terminals | - Check harness between terminals for continuity. - No continuity indicates that harness is open or poorly connected. | Repair or replace the harness. |

FAULT DIAGNOSIS OF ELECTRICAL SYSTEM

Fig. : 2-5

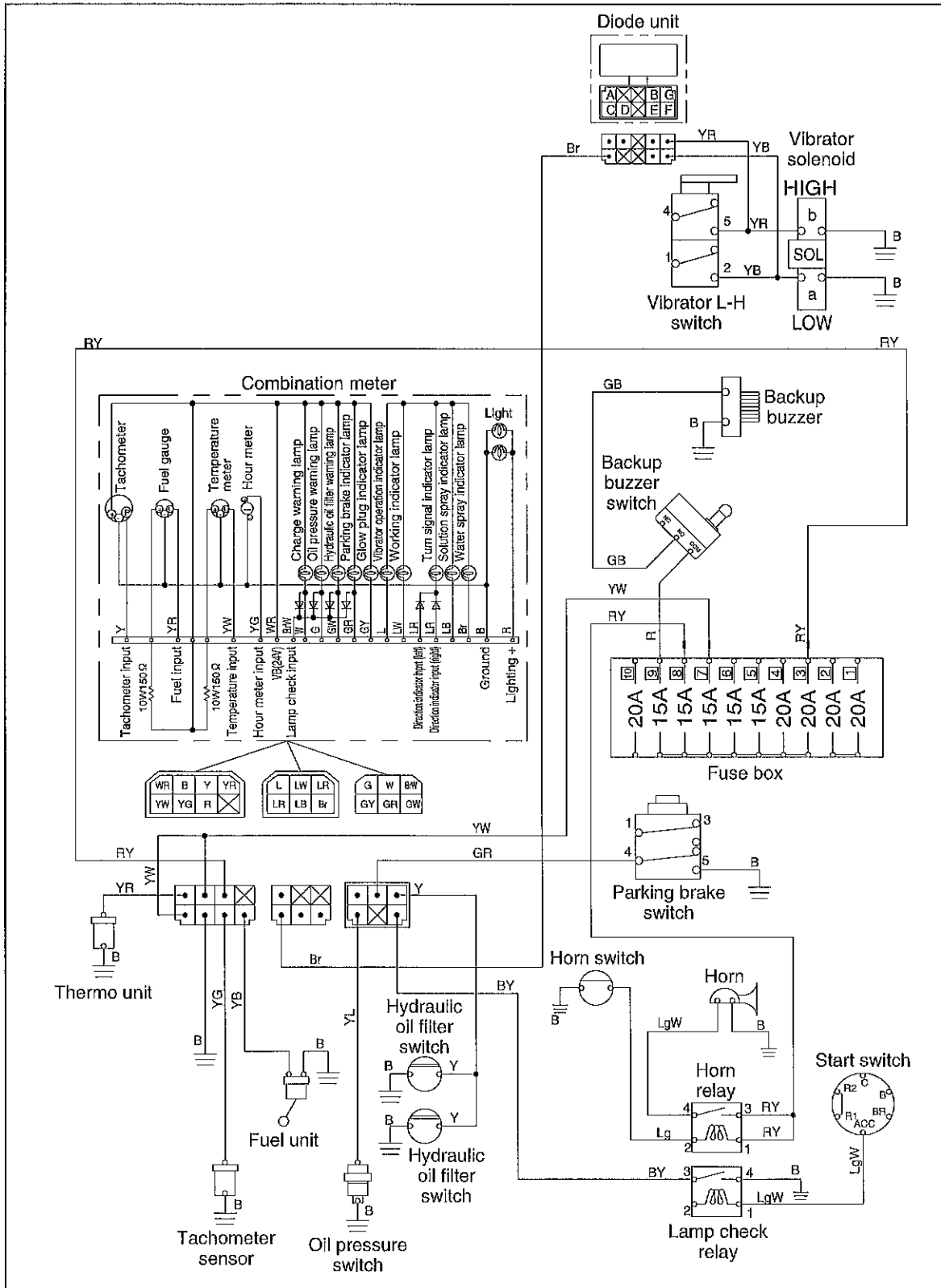

9-030

FAULT DIAGNOSIS OF ELECTRICAL SYSTEM

2-5-11. Backup Buzzer Does Not Beep

Reference Fig. : 2-5

| Check point | Check/Cause | Action |
|---|---|-----------------------------------|
| 1. Buzzer | - Disconnect buzzer and connect the buzzer terminal to the battery directly. - If the buzzer does not beep, it is faulty. | Replace the buzzer. |
| 2. Backup Buzzer Switch | (1) When the forward/reverse lever is in the reverse position, measure the voltage between the backup buzzer switch COM pin inlet G wire and chassis ground. Standard voltage: 24V or more (2) When the forward/reverse lever is in the reverse position, measure the voltage between the backup buzzer switch NO pin inlet GB wire and chassis ground. Standard voltage: 24V or more - If above item (1) is OK and item (2) is NG, the backup buzzer switch is faulty. | Replace the backup buzzer switch. |
| 3. Harness Connecting Between Terminals | - Check harness between terminals for continuity. - No continuity indicates that harness is open or poorly connected. | Repair or replace the harness. |

3. HYDRAULIC SYSTEM TROUBLESHOOTING

3-1. When performing hydraulic system troubleshooting

- The largest factor in the majority of failures of hydraulic devices operating under conditions of higher pressure and greater precision is the entry of dirt (foreign substances) into the hydraulic circuit. Particular caution is required when supplying hydraulic oil or when disassembling and assembling hydraulic devices.

1) Pay attention to the work environment.

As much as possible, avoid performing tasks such as supplying hydraulic oil, replacing filters and repair work on rainy days, when there is strong wind, or in locations where there is much dust.

2) Disassembly and maintenance work in the field

There is the danger of dust entry when disassembly and maintenance work for hydraulic devices is performed in the field. In addition, because performance verification after repairs are completed is difficult, replacement of the entire assembly is preferred. Perform disassembly and maintenance of hydraulic devices in a special room protected from dust, and use special testers to verify the performance.

3) Sealing of openings

Use caps, tape, plastic bags or other means to seal the openings of removed pipes and devices in order to prevent foreign substances from entering. Never leave the openings exposed or put a shop cloth into them. There is the danger of foreign substances entering or of leaking oil causing environmental contamination.

Do not dispose of waste oil on-site. Either deliver it to the customer and request disposal or take it back with you and dispose of it.

4) Prevent entry of foreign substances when supplying oil.

Take care that foreign substances do not enter when supplying hydraulic oil. Clean the oil supply port and the area around it, as well as the supply pump, oilcan and other items. A more reliable method is to use oil cleaning equipment, which can filter out the contamination that occurred during storage.

5) Change hydraulic oil while the temperature is still high.

All oils, including hydraulic oil, are softer and flow more readily when they are warm. Higher temperatures also make it easier to eject the sludge and other substances outside the circuit together with the oil. For these reasons, oil changes should be performed while the oil temperature is high. When changing the oil, it is necessary to drain out as much of the old hydraulic oil as possible. (In addition to the hydraulic oil tank, also drain the oil from the filter and circuit drain plugs.) If old hydraulic oil remains in the system, the contaminants and sludge in the old oil will mix with the new oil and shorten the hydraulic oil lifetime.

3-2. Propulsion

If a problem occurs in the propulsion system such as propulsion pump, propulsion motor or brake, determine the cause and carry out action as required, according to the following general troubleshooting items.

- When checking whether or not the pressure is correct, refer to the pressure standard value for each hydraulic circuit.

3-2-1. Vehicle Moves Neither Forward Nor Backward

| Check point | Cause | Check/Action |
|--|---|---|
| 1. Oil Level of Hydraulic Oil Tank | Oil level in hydraulic oil tank is low. | Fill the tank until the correct oil level is obtained. |
| 2. Forward/Reverse Lever Linkage | Forward/reverse lever linkage is faulty. | Check the forward/reverse lever linkage, and then adjust or replace as required. |
| 3. Charge Circuit Pressure | Propulsion pump does not discharge oil because charge pressure is low. | Measure the charge pressure. If low, check the propulsion or vibrator charge relief valve, and then adjust or replace the valve. |
| | Insufficient charge pump discharge. | Repair or replace charge pump. |
| | Charge pressure decreases due to internal leakage of solenoid valve connecting oil supply circuit with charge circuit. - Brake solenoid valve - Speed change solenoid valve | When the solenoid is not energized, check if oil flows in return circuit to tank. If oil flows, carry out the following actions. - Repair or replace the solenoid valve. - Repair or replace the solenoid valve. |
| 4. Suction Filter for Charge Pump | The charge pump flow is reduced due to clogged filter. | Clean or replace the suction filter. |
| 5. Pressure in Propulsion Circuit | The circuit does not obtain the required pressure because the setting pressure of relief valve is low. | Measure the propulsion circuit pressure. If low, check multifunction valve, and then adjust or replace as required. |
| 6. Propulsion Motor | Internal leakage of propulsion motor. | Measure the drain quantity from propulsion motor. If the drain quantity is larger than the standard value, repair or replace the motor. |
| 7. Brake Release Input Pressure | The brakes are not released because the brake release pressure is too low. | (1) Measure the brake release inlet pressure. (2) Measure the brake solenoid valve inlet pressure when the solenoid is not energized. - If above measurement (1) shows low pressure and (2) is OK, then repair or replace the brake cylinder. |
| 8. Brake Solenoid valve | Brake is still applied because the spool of the brake solenoid valve does not shift. | Repair or replace the brake solenoid valve. |
| 9. Rear axle (inside brake) | Sticking of the disc brakes causes the brakes to remain applied. | Replace the disc brake. |
| 10. Differential lock valve (for switching between differential, differential lock and bypass) | The differential lock valve spool is in the bypass (unload) state. | - If electricity is applied to the solenoid and the status is bypass (unload), interrupt the electricity supply. - If the spool is stuck and the state is bypass (unload), clean the spool or replace the differential lock valve. |

HYDRAULIC SYSTEM TROUBLESHOOTING

3-2-1. Vehicle Moves Neither Forward Nor Backward

| Check point | Cause | Check/Action |
|-------------------------|---|---|
| 11. Flow Dividing Valve | The oil flow is not divided because the spool is stuck on one side, interrupting the hydraulic circuit. | Clean the spool or replace the flow dividing valve. |
| 12. Coupling | Drive torque is not transmitted to pump due to faulty coupling. | Replace the coupling. |

3-2-2. Vehicle Moves In One Direction Only (Forward Or Backward)

| Check point | Cause | Check/Action |
|----------------------------------|--|---|
| 1. Forward/Reverse Lever Linkage | Forward/reverse lever linkage is faulty. | Check the forward/reverse lever linkage, and then adjust or replace as required. |
| 2. Multifunction Valve | Circuit pressure decreases due to high pressure relief setting failure or internal leakage of multifunction valve. | Swap the two multifunction valves, If the problem changes direction when multifunction valves are swapped, check the multifunction valve, then adjust or replace the defective valve. |

3-2-3. Slow Vehicle Speed Or Small Drive Force

| Check point | Cause | Check/Action |
|---|---|--|
| 1. Forward/Reverse Lever Linkage | Forward/reverse lever linkage is faulty. | Check the forward/reverse lever linkage, and then adjust or replace as required. |
| 2. Charge Pressure | Stroke of the propulsion pump swash plate is small because charge pressure is low, decreasing the discharge rate of propulsion pump. | Measure the charge pressure. If low, check the propulsion or vibrator charge relief valve, and then adjust the setting pressure or replace the valve. |
| | Insufficient charge pump discharge | Repair or replace charge pump. |
| | Charge pressure decreases due to internal leakage of solenoid valve connecting oil supply circuit with charge circuit. - Brake Solenoid Valve - Speed change solenoid valve | When the solenoid is not energized, check if oil flows in return circuit to tank. If oil flows, carry out the following actions. - Repair or replace the solenoid valve. - Repair or replace the solenoid valve. |
| 3. Suction Filter for Charge Pump | The flow rate of charge pump decreases as well as the charge pressure decreases due to clogged filter. | Clean or replace the suction filter. |
| 4. Propulsion Motor Input Pressure | Propulsion motor inlet pressure is low. | Measure the propulsion motor inlet pressure. If low, check the multifunction valve, then adjust or replace the valve. |
| 5. Internal Leakage of Propulsion Motor | The output of propulsion motor decreases and the number of revolutions decreases due to internal leakage of propulsion motor. | Measure the drain quantity from propulsion motor. If the drain quantity is larger than the standard value, repair or replace the motor. |
| 6. Propulsion Pump | Discharge flow rate is insufficient due to efficiency degradation of propulsion pump. | Measure the discharge flow rate of propulsion pump with flow meter. If the discharge flow rate is not within the specified range, repair or replace the propulsion pump. |

HYDRAULIC SYSTEM TROUBLESHOOTING

3-2-4. Vehicle Speed Does Not Change

| Check point | Cause | Check/Action |
|--|--|---|
| 1. Charge Pressure | The propulsion motor swash plate does not move because the charge pressure is low. | Measure the charge pressure. If low, check the propulsion or vibrator charge relief valve, and then adjust or replace the valve. |
| | Insufficient charge pump discharge | Repair or replace charge pump. |
| | Charge pressure decreases due to internal leakage of solenoid valve connecting oil supply circuit with charge circuit. - Brake Solenoid Valve | When the solenoid is not energized, check if oil flows in return circuit to tank. If oil flows, carry out the following actions. - Repair or replace the solenoid valve. |
| 2. Speed Change Solenoid Valve | The vehicle speed does not change because the spool of the speed change solenoid valve does not change. | Repair or replace the speed change solenoid valve. |
| 3. Rear Propulsion Motor Swash-Plate Stroke Cylinder | The rear propulsion motor swash-plate stroke cylinder is faulty. | Replace the rear propulsion motor. |

3-2-5. Vehicle Does Not Stop Completely With Forward/Reverse Lever In Neutral Position

| Check point | Cause | Check/Action |
|-----------------------------------|--|--|
| 1. Forward/Reverse Lever Linkage | Forward/reverse lever linkage is faulty. | Check the forward/reverse lever linkage, and then adjust or replace as required. |
| 2. Servo Control Valve | Servo control valve neutral position adjustment failure. | Check the servo control valve, and then adjust or replace as required. |
| 3. Propulsion Pump Servo Cylinder | Faulty propulsion pump servo cylinder or pump swash plate setting failure. | Replace the propulsion pump. |

3-2-6. Driving Not Possible With Differential Locked

| Check point | Cause | Check/Action |
|----------------------------|--|--|
| 1. Differential Lock Valve | The differential lock valve spool does not move. | Repair or replace the differential lock valve. |

HYDRAULIC SYSTEM TROUBLESHOOTING

3-2-7. Propulsion System Is Overheating

| Check point | Cause | Check/Action |
|---|---|--|
| 1. Oil Level of Hydraulic Oil Tank | Oil level in hydraulic oil tank is low. | Fill the tank until the correct oil level is obtained. |
| 2. Oil Cooler | Cooling efficiency is reduced due to clogged oil cooler fins. | Clean the oil cooler fin. |
| 3. Flushing Valve | Hydraulic oil in propulsion closed circuit is insufficiently cooled due to flushing valve shuttle spool sticking. | Repair or replace the flushing valve. |
| | Hydraulic oil in the propulsion closed circuit is insufficiently cooled because flushing valve relief setting pressure is excessively high. | Adjust the flushing valve relief setting pressure or replace the flushing valve. |
| | Hydraulic oil in the propulsion closed circuit is insufficiently cooled due to sticking of the relief valve poppet on the flushing valve. | Clean or replace the relief valve. |
| 4. Setting Pressure in Propulsion Circuit | If the circuit pressure setting is excessively low, the relief valve is open, causing the temperature of hydraulic oil in circuit to rise. | Measure the propulsion circuit pressure. If low, increase the relief setting pressure. |
| | If the load is excessively heavy, the relief valve is open, causing the temperature of hydraulic oil in circuit to rise. | Measure the propulsion circuit pressure. If high, decrease the propulsion load. |
| 5. Suction Filter for Charge Pump | The load of charge pump increases due to clogged filter, causing the temperature of hydraulic oil in circuit to rise. | Clean or replace the suction filter. |
| 6. Charge Line Filter | Charge circuit pressure increases due to clogged filter. | Clean or replace the line filter. |

3-2-8. Abnormal Noise From Propulsion System

| Check point | Cause | Check/Action |
|-----------------------------------|---|---|
| 1. Front Axle Bearings | Axle bearing supporting front wheels is damaged. | Replace the axle bearing. |
| 2. Rear Axle | Rear axle bearing is damaged. | Replace the rear axle bearing. |
| | Rear axle bearing is damaged. | Rear axle gear is damaged. |
| 3. Hydraulic Hose Clamp | Vibrator sound of hydraulic hose is generated because the clamp securing the hydraulic hose is loose. | Tighten bolts of the loose hydraulic hose clamp to the specified torque. |
| 4. Suction Filter for Charge Pump | Cavitation is occurring in charge pump due to clogged filter. | Clean or replace the suction filter. |
| 5. Charge Circuit Pressure | If charge circuit pressure is low, the brake cannot be released completely, causing brake drag. | Measure the charge pressure. If low, check the charge relief valve, and then adjust or replace the valve. |
| 6. Propulsion Motor | Internal bearing of propulsion motor is damaged. | Repair or replace the propulsion motor. |

3-3. Vibrator

If a problem occurs in the vibrator system such as vibrator pump, vibrator motor, or vibrator solenoid valve, determine the cause and carry out action as required, according to the following general troubleshooting items.

- When checking whether or not the pressure is correct, refer to the pressure standard value for each hydraulic circuit.

3-3-1. No Vibration

| Check point | Cause | Check/Action |
|------------------------------------|---|--|
| 1. Oil Level of Hydraulic Oil Tank | Oil level in hydraulic oil tank is low. | Fill the tank until the correct oil level is obtained. |
| 2. Pressure in Vibrator Circuit | The circuit does not obtain the required pressure because the pressure setting of relief valve is low. | Measure the vibrator circuit pressure. If low, check the relief valve, and then adjust or replace as required. |
| 3. Charge Circuit Pressure | Vibrator pump does not discharge oil because charge pressure is low. | Measure the charge pressure. If low, check the propulsion or vibrator charge relief valve, and then adjust or replace the valve. |
| | Insufficient charge pump discharge. | Repair or replace charge pump. |
| | Charge pressure decreases due to internal leakage of solenoid valve connecting oil supply circuit with charge circuit. - Brake Solenoid valve - Speed change solenoid valve | When the solenoid is not energized, check if oil flows in return circuit to tank. If oil flows, carry out the following actions. - Repair or replace the solenoid valve. - Repair or replace the solenoid valve. |
| 4. Vibrator Solenoid valve | Vibrator pump does not discharge oil because the spool of the vibrator solenoid valve does not shift. | Repair or replace the vibrator solenoid valve. |
| 5. Vibrator Pump | The pump discharge rate is insufficient due to efficiency degradation of vibrator pump. | Measure the discharge flow rate of vibrator pump with flow meter. If the discharge flow rate is not within the specified range, repair or replace the vibrator pump. |
| | The pump is not discharging oil due to wear of the vibrator pump drive shaft spline. | Replace the vibrator pump. |
| 6. Vibrator Motor | Internal leakage of vibrator motor. | Measure the drain quantity from vibrator motor. If the drain quantity is larger than the standard value, repair or replace the motor. |
| | Output torque is not transmitted due to worn spline of vibrator motor output shaft. | Replace the vibrator motor. |

HYDRAULIC SYSTEM TROUBLESHOOTING

3-3-2. Vibrator Frequency Is Too Low

| Check point | Cause | Check/Action |
|--|---|--|
| 1. Oil Level of Hydraulic Oil Tank | Oil level in hydraulic oil tank is low. | Fill the tank until the correct oil level is obtained. |
| 2. Charge Pressure | The stroke of the vibrator pump swash plate is small because the charge pressure is low, decreasing the discharge rate of the vibrator pump. | Measure the charge pressure. If low, check the propulsion or vibrator charge relief valve, and then adjust or replace the valve. |
| | Insufficient charge pump discharge | Repair or replace charge pump. |
| | Charge pressure decreases due to internal leakage of solenoid valve connecting oil supply circuit with charge circuit. - Brake solenoid valve - Speed change solenoid valve | When the solenoid is not energized, check if oil flows in return circuit to tank. If oil flows, carry out the following actions. - Repair or replace the solenoid valve. - Repair or replace the solenoid valve. |
| 3. Vibrator Motor Inlet Pressure | Vibrator motor inlet pressure is low. | Measure the vibrator motor inlet pressure. If low, check the relief valve, and then adjust or replace the valve. |
| 4. Internal Leakage of Vibrator Motor | Vibrator motor revolutions decrease due to internal leakage of the vibrator motor. | Measure the drain quantity from vibrator motor. If the drain quantity is larger than the standard value, repair or replace the motor. |
| 5. Pressure Setting in Vibrator Circuit Relief valve | Low circuit pressure due to incorrect relief setting. | If the reverse phenomenon occurs when the relief valves in the high/low vibrator circuits are exchanged with each other, check the relief valves, then adjust or replace the valves. |
| 6. Vibrator Pump | The pump discharge rate decreases due to efficiency degradation of vibrator pump. | Use a flow meter to measure the amount of vibrator pump discharge. If it is lower than the standard flow amount, repair or replace the vibrator pump. |

3-3-3. Vibrator L-H Does Not Switch

| Check point | Cause | Check/Action |
|----------------------------|---|--|
| 1. Vibrator Solenoid Valve | The vibrator solenoid valve spool changes only to one side. | Repair or replace the vibrator solenoid valve. |

3-3-4. Vibrator Does Not Stop

| Check point | Cause | Check/Action |
|----------------------------|--|--|
| 1. Vibrator Solenoid Valve | Spool of vibrator solenoid valve does not return to neutral position. | Repair or replace the vibrator solenoid valve if the spool of the valve does not return to neutral position. |
| 2. Vibrator Pump | The vibrator pump swash plate does not return to the neutral position. | Repair or replace the vibrator pump. |

HYDRAULIC SYSTEM TROUBLESHOOTING

3-3-5. Vibrator System Is Overheating

| Check point | Cause | Check/Action |
|---|--|--|
| 1. Oil Level of Hydraulic Oil Tank | Oil level in hydraulic oil tank is low. | Fill the tank until the correct oil level is obtained. |
| 2. Oil Cooler | Cooling efficiency is reduced due to clogged oil cooler fins. | Clean the oil cooler fin. |
| 3. Pressure Setting in Vibrator Circuit | If the circuit pressure setting is excessively low, the relief valve is open, causing the temperature of hydraulic oil in circuit to rise. | Measure the vibrator circuit pressure. If low, increase the relief pressure setting. |
| | If the load is excessively heavy, the relief valve is open, causing the temperature of hydraulic oil in circuit to rise. | Measure the vibrator circuit pressure. If high, decrease the vibrator load. |

3-3-6. Abnormal Noise From Vibrator System

| Check point | Cause | Check/Action |
|--------------------------------------|---|--|
| 1. Oil Level of Hydraulic Oil Tank | Pump suction pressure is high because oil level of hydraulic oil tank is low, causing cavitation in vibrator circuit. | Fill the tank until the correct oil level is obtained. |
| 2. Air in Vibrator Hydraulic Circuit | Cavitation is caused by air in the circuit. | Check pump inlet hose connection and hydraulic tank connection |
| 3. Vibrator Bearing | Vibrator bearing supporting the eccentric shaft is damaged. | Replace the vibrator bearing. |
| 4. Hydraulic Hose Clamp | Vibrator sound of hydraulic hose is generated because the clamp securing the hydraulic hose is loose. | Tighten bolts of the loose hydraulic hose clamp to the specified torque. |
| 5. Power Transmission Coupling | Noise is generated from power transmission shaft because coupling backlash is large. | If coupling wear is large, replace the coupling. |

HYDRAULIC SYSTEM TROUBLESHOOTING

3-4. Steering

If a problem occurs in steering system such as steering pump or orbit roll, determine the cause and carry out action as required, according to the following general troubleshooting items.

- When checking whether or not the pressure is correct, refer to the pressure standard value for each hydraulic circuit.

3-4-1. Steering Wheel Is Hard To Turn

| Check point | Cause | Check/Action |
|-------------------------------------|---|---|
| 1. Oil Level of Hydraulic Oil Tank | Oil level in hydraulic oil tank is low. | Fill the tank until the correct oil level is obtained. |
| 2. Orbitrol | Relief valve is open or setting pressure is low. | Measure the steering circuit pressure. If low, check relief valve, and then clean the valve or increase the setting pressure. |
| | Flow to the steering cylinder circuit is insufficient due to leakage from the check valve. | Check the check valve, and then clean or replace as required. |
| | Spool and sleeve of the orbitrol are contaminated or clearance is incorrect. | Check the orbitrol, and then clean or replace as required. |
| 3. Steering Circuit Pressure | Pressure in the return circuit from orbitrol increases due to clogged charging line filter. | Clean or replace the line filter. |
| 4. Steering Cylinder | Cylinder thrust decreases due to internal leakage of steering cylinder. | Repair or replace the steering cylinder. |
| 5. Suction Filter for Steering Pump | Steering pump discharge rate decreases due to clogged filter. | Clean or replace the suction filter. |
| 6. Steering Pump | Discharging pressure is insufficient due to efficiency degradation of steering pump. | Measure the steering circuit pressure. If low, replace the steering pump. |
| 7. Steering column | Column shaft and orbitrol shaft center are misaligned. | Align the column shaft with orbit roll shaft center or replace column shaft. |
| | Column shaft bearing is worn or damaged. | Repair or replace the column shaft. |

3-4-2. Steering Response Is Slow

| Check point | Cause | Check/Action |
|-------------------------------------|--|--|
| 1. Oil Level of Hydraulic Oil Tank | Oil level in hydraulic oil tank is low. | Fill the tank until the correct oil level is obtained. |
| 2. Orbitrol | Oil bypasses the passage from relief valve because the relief valve is open. | Measure the steering circuit pressure. If low, check the relief valve, and then adjust or replace as required. |
| 3. Steering Cylinder | Internal leakage of steering cylinder | Repair or replace the steering cylinder. |
| 4. Suction Filter for Steering Pump | Steering pump discharge rate decreases due to clogged filter. | Clean or replace the suction filter. |
| 5. Steering Pump | Discharge rate is insufficient due to efficiency degradation of steering pump. | Measure the steering circuit pressure. If low, replace the steering pump. |

HYDRAULIC SYSTEM TROUBLESHOOTING

3-4-3. Steering Wheel Backlash Or Play Is Large

| Check point | Cause | Check/Action |
|--------------------|--|---------------------------------------|
| 1. Steering Column | Spline of column shaft or orbitrol is worn. | Replace the column shaft or orbitrol. |
| | Column shaft bearing is worn. | Replace the column shaft bearings. |
| 2. Steering Wheel | Serration (spline) of wheel or column shaft is worn. | Replace the wheel or column shaft. |

3-4-4. Steering System Is Overheating

| Check point | Cause | Check/Action |
|--------------------------------------|--|--|
| 1. Oil Level of Hydraulic Oil Tank | Oil level in hydraulic oil tank is low. | Fill the tank until the correct oil level is obtained. |
| 2. Oil Cooler | Cooling efficiency is reduced due to clogged oil cooler fins. | Clean the oil cooler fin. |
| 3. Steering Circuit Setting Pressure | If the circuit pressure setting is excessively low, the relief valve is open, causing the temperature of hydraulic oil in circuit to rise. | Measure the steering circuit pressure. If low, increase the relief setting pressure. |
| | If the load is excessively heavy, the relief valve is open, causing the temperature of hydraulic oil in circuit to rise. | Measure the steering circuit pressure. If high, decrease the steering load. |
| 4. Suction Filter for Steering Pump | The load of steering pump increases due to clogged filter, causing the temperature of hydraulic oil in circuit to rise. | Clean or replace the suction filter. |

3-4-5. Abnormal Noise From Steering System

| Check point | Cause | Check/Action |
|--|--|--|
| 1. Oil Level of Hydraulic Oil Tank | Pump suction pressure is high because oil level of hydraulic oil tank is low, causing cavitation in the steering system circuit. | Fill the tank until the correct oil level is obtained. |
| 2. Air in the Steering Hydraulic Circuit | Cavitation is caused by air in the circuit. | Check pump inlet hose connection and hydraulic tank connection |
| 3. Hydraulic Hose Clamp | Vibrator sound of hydraulic hose is generated because the clamp securing the hydraulic hose is loose. | Tighten bolts of the loose hydraulic hose clamp to the specified torque. |
| 4. Suction Filter for Steering Pump | Cavitation results at the steering pump due to clogged filter. | Clean or replace the suction filter. |

HYDRAULIC SYSTEM TROUBLESHOOTING

3-5. Blade (SV510TB/TFB-II)

If a problem occurs in the blade control system, determine the cause and carry out action as required, according to the following general troubleshooting items.

- When checking whether or not the pressure is correct, refer to the pressure standard value for each hydraulic circuit.

3-5-1. Blade Up/Down Operation Not Possible

| Check point | Cause | Check/Action |
|---|--|---|
| 1. Oil Level of Hydraulic Oil Tank | Oil level in hydraulic oil tank is low | Fill the tank until the correct oil level is obtained. |
| 2. Flow Dividing Valve (Steering Blade) for Separation | The oil flow is not divided because the spool is stuck on one side, interrupting the hydraulic circuit. | Clean the spool or replace the flow dividing valve. |
| 3. Blade Circuit Pressure | The circuit does not obtain the required pressure because the setting pressure of the control valve relief valve is low. | Measure the blade circuit pressure. If low, check the relief valve, and then adjust or replace the valve. |
| 4. Control Valve | The blade cylinder does not operate because the control valve spool does not change. | If the control valve lever does not move, check and clean the spool, or replace the control valve. |
| 5. Blade Cylinder | Cylinder thrust decreases due to internal leakage of the blade cylinder. | Repair or replace the blade cylinder. |
| 6. Steering Pump Suction Filter (also used for blade circuit) | Steering pump discharge rate decreases due to clogged filter. | Clean or replace the suction filter. |
| 7. Steering Pump (also used for blade circuit) | Discharging pressure is insufficient due to efficiency degradation of steering pump. | Measure the steering circuit pressure. If low, replace the steering pump. |
| 8. Steering Column | Column shaft and orbitrol shaft center are misaligned. | Align the column shaft with orbit roll shaft center or replace column shaft. |
| | Column shaft bearing is worn or damaged. | Repair or replace the column shaft. |

3-5-2. Blade Movement Is Slow Or Force Is Small

| Check point | Cause | Check/Action |
|---|--|---|
| 1. Oil Level of Hydraulic Oil Tank | Oil level in hydraulic oil tank is low. | Fill the tank until the correct oil level is obtained. |
| 2. Control Valve | Oil bypasses the passage from the relief valve because the control valve relief valve is open. | Measure the blade circuit pressure. If low, check the relief valve, and then adjust or replace the valve. |
| 3. Blade Cylinder | Internal leakage of blade cylinder | Repair or replace the blade cylinder. |
| 4. Steering Pump Suction Filter (also used for blade circuit) | Steering pump discharge rate decreases due to clogged filter. | Clean or replace the suction filter. |
| 5. Steering Pump (also used for blade circuit) | Discharge rate is insufficient due to efficiency degradation of steering pump. | Measure the steering circuit pressure. If low, replace the steering pump. |

HYDRAULIC SYSTEM TROUBLESHOOTING

3-5-3. Blade Floating Operation Not Possible

| Check point | Cause | Check/Action |
|------------------|---|--|
| 1. Control Valve | Blade floating operation is not possible because the control valve spool does not change. | If the control valve lever does not move, check and clean the spool, or replace the control valve. |

3-5-4. Blade Hydraulic System Is Overheating

| Check point | Cause | Check/Action |
|---|--|---|
| 1. Oil Level of Hydraulic Oil Tank | Oil level in hydraulic oil tank is low. | Fill the tank until the correct oil level is obtained. |
| 2. Oil Cooler | Cooling efficiency is reduced due to clogged oil cooler fins. | Clean the oil cooler fin. |
| 3. Blade Circuit Setting Pressure | If the circuit pressure setting is excessively low, the relief valve is open, causing the temperature of hydraulic oil in circuit to rise. | Measure the blade circuit pressure. If low, increase the relief setting pressure. |
| | If the load is excessively heavy, the relief valve is open, causing the temperature of hydraulic oil in circuit to rise. | Measure the blade circuit pressure. If high, decrease the steering load. |
| 4. Steering Pump Suction Filter (also used for blade circuit) | The load of steering pump increases due to clogged filter, causing the temperature of hydraulic oil in circuit to rise. | Clean or replace the suction filter. |

3-5-5. Abnormal Noise From Blade Hydraulic System

| Check point | Cause | Check/Action |
|---|--|--|
| 1. Oil Level of Hydraulic Oil Tank | Pump suction pressure is high because oil level of hydraulic oil tank is low, causing cavitation in the steering system circuit. | Fill the tank until the correct oil level is obtained. |
| 2. Air in the Blade Hydraulic Circuit | Cavitation is caused by air in the circuit. | Check pump inlet hose connection and hydraulic tank connection |
| 3. Hydraulic Hose Clamp | Vibrator sound of hydraulic hose is generated because the clamp securing the hydraulic hose is loose. | Tighten bolts of the loose hydraulic hose clamp to the specified torque. |
| 4. Steering Pump Suction Filter (also used for blade circuit) | Cavitation results at the steering pump due to clogged filter. | Clean or replace the suction filter. |

SAKAI HEAVY INDUSTRIES, LTD.

Head office: 1-4-8, Shiba-Daimon, Minato-ku
Tokyo, Japan

Telephone: Tokyo(03) 3431-9971

Facsimile: (03) 3431-6212

Printed in Japan 2008.3.100 © C.D