

SW770/770HF/770ND TENTATIVE SHOP MANUAL

This manual is a preliminary version.

Please replace with the officially published version once it is available.

SAKAI®

3498-64315-0

SAFETY

1. GENERAL SAFETY

1-1. Understanding the Safety Symbols and Words

The words DANGER, WARNING, and CAUTION are used with the safety-alert symbol. DANGER identifies the most serious hazard. When the symbols DANGER, WARNING and CAUTION are displayed, become alert. Your safety or those around you may be involved. NOTICE is used to provide important information that is not hazard related.

 **DANGER:** Indicates an imminently hazardous situation or condition which if not avoided can result in serious personal injury or death.

 **WARNING:** Indicates a potentially hazardous situation or condition which if not avoided can result in serious personal injury or death.

 **CAUTION:** Indicates a potentially hazardous situation or condition which if not avoided may result in moderate personal injury or damage to the machine or personal property.

(NOTICE): Indicates important information about operation or maintenance of the machine that may cause damage, breakdown, or shortened service life of the machine if you fail to observe or important point to maintain of quality in maintenance works.

★: Indicates standard value to judge whether measured value is good or not.



Items that indicate the weight of a part or equipment and require attention in wire selection and operating posture for slinging operation.



In the assembly operation, tightening torque in locations that require particular attention.

1-2. General

- Operators and maintenance personnel must be alert to recognize and avoid potential hazards. They should also have comprehensive training, the required skills and necessary tools to perform the job safely.
- The machine was built in accordance to the latest safety standards and recognized safety rules. Nevertheless, misuse of the machine may result in risk to life and limb of the user or nearby personnel and may cause damage to the machine or other property.
- The machine must only be used for its intended purpose as described in the Operator's Manual. It must be operated by safety-conscious persons who are fully aware of the risks involved when operating the machine. Any malfunctions especially those affecting the safety of the machine must be corrected immediately.

- The machine is designed specifically for the compaction of asphalt or soil road construction materials. Use of the machine for other purposes such as towing other equipment is considered contrary to the designated use. The manufacturer cannot be responsible or held liable for any damage resulting from such use. The risk for such use lies entirely with the user.
- Operating the machine within the limits of its designated use also involves compliance with the inspection and maintenance requirements contained in the Operation and Maintenance Manual.

1-3. Qualifications of Operators and Maintenance Personnel

- Work on the machine must be performed by qualified personnel only. Individual responsibilities of personnel regarding operation, maintenance, repair of the machine must be clearly stated.
- Define the operator's responsibilities; the operator should have authority to refuse instructions that are contrary to safety.
- Do not allow persons being trained to operate or perform maintenance on the machine without constant supervision by an experienced person.
- Work on the electrical system of the machine must be done only by an experienced person or under the guidance of a skilled electrician and according to electrical engineering rules and regulations.
- Work on the frame, brakes, hydraulic and steering systems must be performed by skilled personnel with special knowledge and training for such work.

1-4. Safety Practices and Policies

- Keep the manuals in the container provided on the machine. Manuals must always be available at the site where the machine is being used.
- The operator or user of the machine must be aware of all applicable or legal and mandatory regulations relevant to accident prevention and environmental protection. These regulations may also deal with handling of hazardous substances, the required proper personal safety and protective equipment and traffic or jobsite regulations.
- Machine operating instructions should also be supplemented with detailed instructions pertaining to the specific jobsite or work location.
- Always be sure the persons working on the machine have read the operating instructions and all safety precautions before beginning work. Reading safety instructions after work has already begun is too late.
- Wear close fitting garments and always tie back and secure long hair, also avoid wearing jewelry such as rings. Injury can result from loose clothing, hair or jewelry being caught up in the machinery or rotating parts.
- Use protective equipment as required by the circumstances or by law.

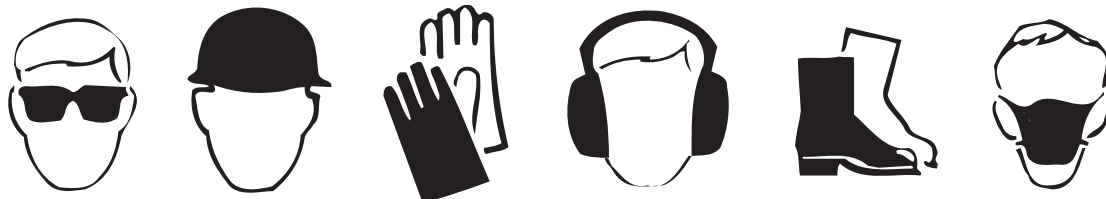

- Observe all safety instructions and warnings attached to the machine.
- Make sure all safety instructions and warnings on the machine are complete and perfectly legible.
- Stop the machine immediately in the event of any malfunction. Report any malfunction immediately to the supervisor or other person of authority.
- Never perform service or maintenance on the machine unless the drums or tires are adequately blocked, articulation lock bar and pin is in the locked position and the parking brake is applied.
- Never make any modifications to the machine which might affect safety without the manufacturer's approval.
- Always perform the recommended routine inspections and adjustments according to the prescribed intervals.

1-5. Pre Start Inspection

- Inspect your machine daily. Ensure that the routine maintenance and lubrication are properly performed. Repair or replace any malfunctioning, broken or missing parts before using the machine. Refer to the maintenance schedule in the Operator's Manual.
- Check that all instructions and safety stickers are in place and readable.
- Never fill the fuel tank with the engine running or while near an open flame or while smoking.
- Always clean up any spilled fuel.
- Check for any warning tags placed on the machine, do not operate the machine until all repairs have been made and warning tags have been removed by authorized personnel.
- Check the seat belt for wear or damage; inspect the belt hardware and fabric. Replace if hardware is damaged or the belt is frayed or nicked or stitching is loose. Check that mounting hardware is tight.
- Clean the steps and operating platform of dirt and foreign matter to reduce danger of slipping.
- Know how to shut-down or stop the machine immediately in case of emergency.
- Know the capabilities and limitations of the machine such as speed, gradeability, steering and braking.
- Be aware of the dimensions of the machine such as height, weight especially for transporting.

1-6. Safety Instructions

- Take all necessary precautions to ensure that the machine is used only when in a safe and reliable condition.
- Avoid any operational mode that might compromise safety.
- Operate the machine only if all protective and safety devices are in place and fully functional.
- Always use the hand rails and steps to get on and off your machine maintaining 3-point contact (using both hands).

1-7. Starting

- Start the machine only from the driver's seat and always wear the seat belt.
- Watch that the warning lights and indicators during start-up and shutdown are working in accordance with operating instructions.
- Watch that no one is in danger before starting and when moving the machine.
- Check that braking, steering, signals and lights are fully functional before starting work or traveling with the machine.

1-8. Operating

- Always make sure that there are no obstructions or persons in your line of travel before starting the compactor in motion.
- Never climb on and off the machine while it is in motion.
- Always remain seated with the seat belt fastened when traveling, compacting or loading or unloading the machine.
- Use caution and be very observant when operating in close quarters and congested areas.
- Obey all traffic regulations when working on public roads and make sure machine is compatible with these regulations.
- Never carry passengers.
- Know and use the hand signals for particular jobs and who has the responsibility for signaling.
- Do not work close to edges or in the vicinity of overhanging banks or on grades that could cause the compactor to slide or roll over. Avoid any areas that may be a risk to machine stability.
- Avoid side hill travel. Always operate up and down the slope. Always keep the propulsion (travel control) lever in low speed range when climbing or descending hills or steep grades.
- Make sure there is sufficient clearance when crossing underpasses, bridges and tunnels or when passing under overhead power lines.
- Never allow anyone to stand in the articulation area of the machine when the engine is running.
- Always look in all directions before reversing the direction of travel.
- Always switch on the lighting system (if equipped) during poor visibility conditions and after dark.
- Do not attempt to control the compactor travel speed with the throttle control. Maintain engine speed at the full operating RPM.
- Do not run the engine in a closed building for an extended period of time. Exhaust fumes can kill.

1-9. Stopping

- Always park the machine in a safe area on solid and level ground. If this is not possible, always park at a right angle to the slope and block the drums or tires.
- Do not leave the operator's platform with the engine running. Always move the travel lever to neutral position and apply the parking brake then turn the starter switch to OFF.
- Lock all lockable compartments.

- Park behind a safe barrier, use proper flags, and warning devices, especially when parking in areas of heavy traffic.

1-10. Maintenance

- In any performing any work concerning the operation, adjustment or modification of the machine or it's safety devices or any work related to maintenance, inspection or repair, always follow the start-up and shut-down procedures in the Operator's Manual and the Maintenance Manual.
- Ensure that the maintenance area is safe and secure.
- If the machine is shut down for maintenance or repair work it must be secured against inadvertent starting by removing the starter key and attaching a warning sign to the starter switch.
- The machine must be parked on stable and level ground with the drums or tires blocked to prevent inadvertent movement.
- Immediately after the engine has stopped, the exhaust system, engine, radiator coolant, engine oil, hydraulic fluid and other lubricants and components will be very hot. Fluids can be under pressure, removing the radiator cap or draining oil or changing filters can cause serious burns. Wait until the machine has cooled down.
- Use care when attaching and securing lifting tackle to individual parts and large assemblies being removed or repositioned for repair purposes to avoid the risk of accident. Use lifting devices that are in perfect condition and of sufficient lifting capacity. Never stand under suspended loads.
- Always use the proper tools and workshop equipment in good condition when performing maintenance or repairs on the machine.
- Always use specially designed safety ladders and working platforms when working above floor level. Never use machine parts as a climbing aid.
- Keep all steps, handles, handrails, platforms and ladders free from mud, dirt, grease, ice or snow.
- Clean the machine, especially threaded connections of any traces of oil or fuel before carrying out any maintenance or repairs. Never use aggressive detergents. Use lint free cleaning rags.
- Examine all fuel, lubricant and hydraulic fluid lines and connectors for leaks, loose connections chafe marks or damage after cleaning.
- Repair or replace defective parts immediately.
- Whenever possible, avoid servicing or maintenance when the engine is running unless the drums or tires are adequately blocked, the articulation lock bar is in the locked position and the parking brake is applied.

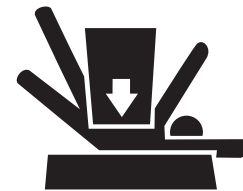

SAFETY

- Never fill the fuel tank with the engine running, while near an open flame or while smoking. Always clean up any spilled fuel.
- Ensure safe operation, optimum performance of the machine and its warranty by using only genuine SAKAI replacement parts.
- Use only the specified fluids and lubricants. Substitute only products known to be equivalent from reputable manufacturers.
- Disconnect the battery cables when working on the electrical system or when welding on the compactor.
- Be sure the battery area is well ventilated (clear of fumes) should it be necessary to connect a jumper cable or battery charger. Fumes can ignite from a spark and may explode.
- Be sure battery charger is OFF when making connections if charging is required.
- Use only original fuses with the specified rating. Switch off the machine immediately if trouble occurs in the electrical system.
- Work on the electrical system may only be carried out by a qualified electrician or by a specially trained person according to electrical engineering principles.
- Inspect the electrical equipment of the machine at regular intervals. Defects such as loose connections or burnt or scorched wires must be repaired or replaced immediately.
- Do not weld, flame cut or perform grinding on the machine unless expressly authorized, as there may be a risk of fire or explosion. Disconnect the battery when welding on the machine.
- Clean the machine and its surrounding from dust or other flammable substances and make sure the area is adequately ventilated before beginning welding, flame cutting or grinding operations.
- Inspect hydraulic hoses at regular intervals and immediately replace if they show signs of chafing, cracking, brittleness, deformation, blistering, fitting separation, leakage, corrosion or other damage which may affect their function or strength.
- Do not work on hydraulic system while the engine is running and the system is under pressure. The hydraulic system remains pressurized even after the engine has stopped.
- Do not disconnect hydraulic hoses or fittings until the pressure has been properly relieved.
- Wait until the systems and fluid have cooled down before disconnecting.
- Never use your hands to check for leaks when inspecting a hydraulic system. Use a piece of cardboard and always wear gloves and safety glasses.



- Get immediate medical attention if fluid has been injected under your skin. Fluid penetration from a pin hole leak can cause severe injury or death.
- Ensure that hydraulic lines and hoses are routed and fitted properly. Ensure that no connections are interchanged. All fittings, lengths and specifications of hoses must comply with the technical requirements.

- Observe all product safety regulations when handling fuel, oils, grease, engine coolant and other chemical substances. Be careful especially when these items are hot as there is a risk of burning or scalding.
- Operate internal combustion engines and fuel operated heating systems only in adequately ventilated premises. Before starting the engine in an enclosed area, make sure there is sufficient ventilation.



1-11. Transporting the Machine

- Use only suitable and approved trailers and haul vehicles and lifting equipment of sufficient capacity.
- Entrust to experienced personnel the fastening and lifting of loads and instructing of crane operators.
- Only experienced persons familiar with the operation of the machine may load and unload the machine.
- Use ramps or a loading dock when loading or unloading the machine. Ramps must be the proper strength, low angle and the proper height and width.
- Block the drums or tires (front and rear) of the hauling vehicle when loading and unloading the compactor. Ensure that the haul vehicle is on level ground and approach the loading ramps squarely to make sure that the compactor does not slide off the edge of the ramp.
- Keep the deck clear of mud, oil, ice or snow or other materials that can make the deck slippery.
- Position the compactor on the trailer or transport vehicle centered from side to side, and apply the brake. Shut off the engine and lock all lockable compartments.
- Block the drums or tires and lock the articulation lock bar. Chain the machine down properly using the appropriate tackle.
- Know the overall height of the compactor and hauling vehicle. Observe height and weight regulations and be sure you can pass safely at overhead obstructions.
- Obey all traffic regulations and be sure that the proper clearance flags, lights and warning signs including "Slow Moving Vehicle" emblem are displayed when traveling on public roads.
- Know the approximate stopping distance at any given speed.
- Drive Safely. Never turn corners at excessive speeds.

SPECIFICATIONS

1. SPECIFICATION DATA

1-1. SW770

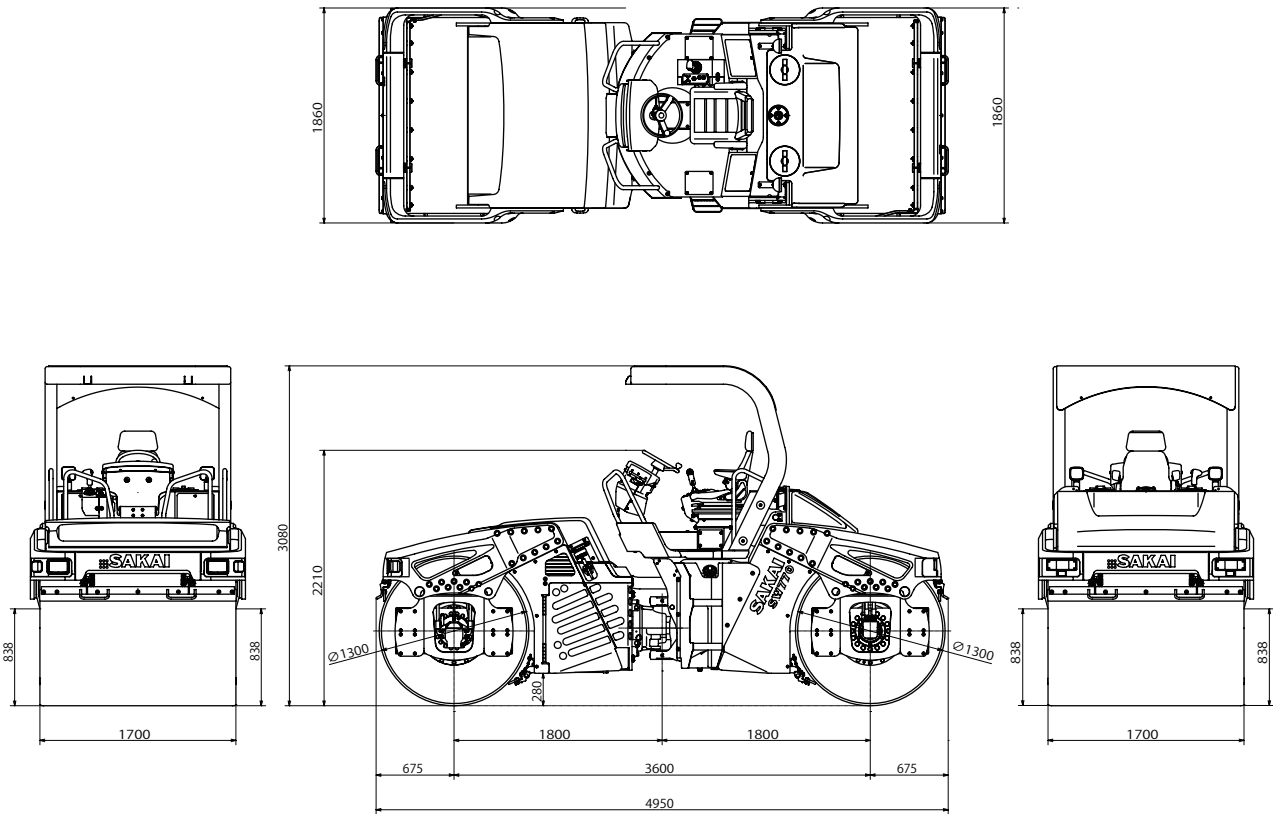

0431-99007-0-10253-A

Model		SW770	
Weight	Operating weight		10,800 kg (23,810 lbs.)
	Front axle		5,200 kg (11,465 lbs.)
	Rear axle		5,600 kg (12,345 lbs.)
Dimensions	Overall length	Frame	4,950 mm (195 in.)
	Overall width	Frame	1,860 mm (73 in.)
	Overall height	Steering wheel	2,210 mm (87 in.)
		ROPS	3,080 mm (121 in.)
	Wheelbase		3,600 mm (142 in.)
	Compaction width		1,700 mm (67 in.)
	Minimum height above ground		280 mm (11 in.)
	Curb clearance		838 mm (32.5 in.)
Speed	Forward/reverse		0 to 12 km/h (0 to 7.5 mph)
Vibration performance	Frequency	Low amplitude	50 Hz
		High amplitude	50 Hz
	Centrifugal force	Low amplitude	68 kN (15,285 lbs.)
		High amplitude	132 kN (29,675 lbs.)
	Amplitude	Low amplitude	0.33 mm (0.013 in.)
High amplitude		0.65 mm (0.026 in.)	
Minimum turning radius		6.3 m (249 in.)	
Gradability *1		28 % (16 °)	

*1: The gradability is the calculated value. It may vary based on the ground surface conditions.

Engine	Name		ISUZU 4JJ1XDIA diesel engine (EPA Tier 3) with turbocharger	
	Model		Water-cooled, 4-cycle, 4-cylinder in-line, overhead camshaft, direct-injection type, with turbocharger	
	Number of cylinders - Bore × Stroke		4-95.4 mm × 104.9 mm (4-3.756 in. × 4.130 in.)	
	Displacement		2.999L (183 cu.in)	
	Performance	Rated speed		2,200 min ⁻¹ (2,200 rpm)
		Rated output		92 kW (123 HP)
		Max. torque		420 N·m (310 lbf·ft) ----- at 1,800 min ⁻¹
		Fuel consumption		206 g/kW·h (0.339 lb/HP·h) ----- at rated speed with silencer and air cleaner, without cooling fan
	Fuel injection system		Full electronic control	
	Fuel injection pump		Common rail HP3 TYPE	
	Lubrication system		Full forced pressure feed type	
	Oil filter		Full flow paper element	
	Oil cooler		Pressurized water forced circulation type	
	Air cleaner		Dry type	
	Cooling system		Centrifugal pump forced feeding system (pressure type)	
	Cooling fan		Inhaling type	
Electrical system	Alternator		24 V 50 A	
	Starter		24 V 4.0 kW	
	Battery		12 V 80 Ah × 2 pcs. (24 V)	
Power line	Transmission	Type	Hydrostatic transmission	
		Speeds	2 speed shifts	
	Reverser	Switching the direction of flow delivered from the variable pump		
Final drive		Planetary gear		
Vibrating system	Transmission		Hydrostatic transmission	
	Vibrator		Eccentric shaft type	
Braking device	Service brake		Hydrostatic and mechanical, multi-wet disc type	
	Parking brake		Mechanical, multi-wet disc type	
Steering system		Hydraulic type (Articulated type)		
Drums	Use	Front drum	Vibration and driving × 1	
		Rear drum	Vibration and driving × 1	
	Dimension (width × dia.)	Front drum	1,700 mm × 1,300 mm (67 in. × 51 in.)	
		Rear drum	1,700 mm × 1,300 mm (67 in. × 51 in.)	
Suspension system	Front drum	Rubber damper type		
	Rear drum	Rubber damper type		
Water spray system		Pressurized type		
Fluid capacity	Cooling water		15L (4.0 gal.)	
	Fuel tank		193L (51 gal.)	
	Engine oil pan		14L (3.7 gal.)	
	Vibrator case		20L × 2 (5.3 gal. × 2)	
	Wheel motor gear case		2.0L × 2 (0.5 gal. × 2)	
	Hydraulic oil tank		50.3L (13 gal.)	
Sprinkler tank		1,000L (264 gal.)		
Others	Instruments and lights		1 set	

SPECIFICATIONS

1-2. SW770HF

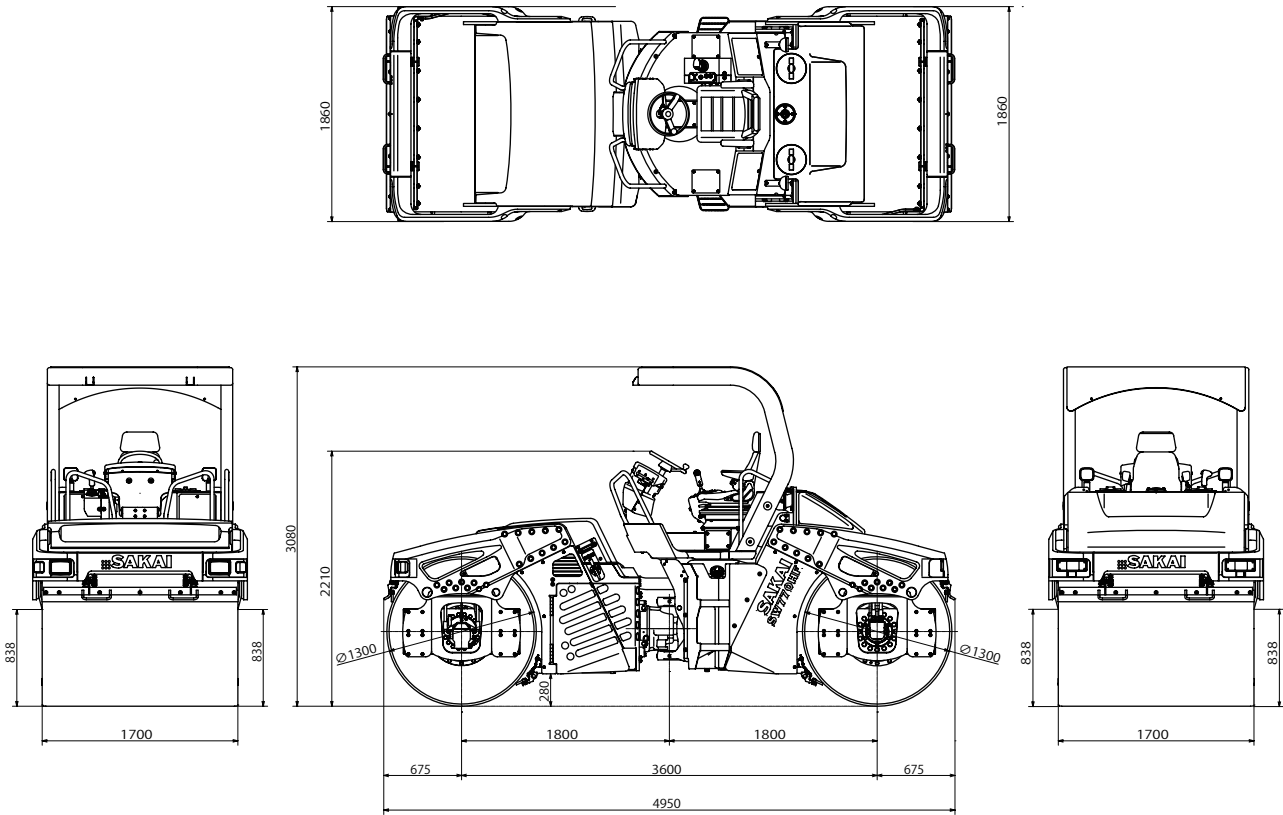

0431-99004-0-10230-A

Model		SW770HF		
Weight	Operating weight		10,800 kg (23,810 lbs.)	
	Front axle		5,200 kg (11,465 lbs.)	
	Rear axle		5,600 kg (12,345 lbs.)	
Dimensions	Overall length	Frame	4,950 mm (195 in.)	
	Overall width	Frame	1,860 mm (73 in.)	
	Overall height	Steering wheel	2,210 mm (87 in.)	
		ROPS	3,080 mm (121 in.)	
	Wheelbase		3,600 mm (142 in.)	
	Compaction width		1,700 mm (67 in.)	
	Minimum height above ground		280 mm (11 in.)	
	Curb clearance		838 mm (32.5 in.)	
Speed	Forward/reverse		0 to 14 km/h (0 to 8.7 mph)	
Vibration performance	Frequency	Low amplitude	1	42 Hz
			2	50 Hz
			3	67 Hz
		High amplitude	1	42 Hz
			2	50 Hz
			3	67 Hz
	Centrifugal force	Low amplitude	1	47 kN (10,565 lbs.)
			2	68 kN (15,285 lbs.)
		High amplitude	1	120 kN (26,975 lbs.)
			2	92 kN (20,680 lbs.)
Amplitude	Low amplitude	1	132 kN (29,675 lbs.)	
	High amplitude	1	0.33 mm (0.013 in.)	
		2	0.65 mm (0.026 in.)	
Minimum turning radius			6.3 m (249 in.)	
Gradability *1			38 % (21 °)	

*1: The gradability is the calculated value. It may vary based on the ground surface conditions.

Engine	Name		ISUZU 4JJ1XDIA diesel engine (EPA Tier 3) with turbocharger	
	Model		Water-cooled, 4-cycle, 4-cylinder in-line, overhead camshaft, direct-injection type, with turbocharger	
	Number of cylinders - Bore × Stroke		4-95.4 mm × 104.9 mm (4-3.756 in. × 4.130 in.)	
	Displacement		2.999L (183 cu.in)	
	Performance	Rated speed		2,200 min ⁻¹ (2,200 rpm)
		Rated output		92 kW (123 HP)
		Max. torque		420 N·m (310 lbf·ft) ----- at 1,800 min ⁻¹
		Fuel consumption		206 g/kW·h (0.339 lb/HP·h) ----- at rated speed with silencer and air cleaner, without cooling fan
	Fuel injection system		Full electronic control	
	Fuel injection pump		Common rail HP3 TYPE	
	Lubrication system		Full forced pressure feed type	
	Oil filter		Full flow paper element	
	Oil cooler		Pressurized water forced circulation type	
	Air cleaner		Dry type	
	Cooling system		Centrifugal pump forced feeding system (pressure type)	
Cooling fan		Inhaling type		
Electrical system	Alternator		24 V 50 A	
	Starter		24 V 4.0 kW	
	Battery		12 V 80 Ah × 2 pcs. (24 V)	
Power line	Transmission	Type	Hydrostatic transmission	
		Speeds	2 speed shifts	
	Reverser		Switching the direction of flow delivered from the variable pump	
Final drive		Planetary gear		
Vibrating system	Transmission		Hydrostatic transmission	
	Vibrator		Eccentric shaft type	
Braking device	Service brake		Hydrostatic and mechanical, multi-wet disc type	
	Parking brake		Mechanical, multi-wet disc type	
Steering system			Hydraulic type (Articulated type)	
Drums	Use	Front drum	Vibration and driving × 1	
		Rear drum	Vibration and driving × 1	
	Dimension (width × dia.)	Front drum	1,700 mm × 1,300 mm (67 in. × 51 in.)	
		Rear drum	1,700 mm × 1,300 mm (67 in. × 51 in.)	
	Suspension system	Front drum	Rubber damper type	
		Rear drum	Rubber damper type	
Water spray system			Pressurized type	
Fluid capacity	Cooling water		15L (4.0 gal.)	
	Fuel tank		193L (51 gal.)	
	Engine oil pan		14L (3.7 gal.)	
	Vibrator case		20L × 2 (5.3 gal. × 2)	
	Wheel motor gear case		2.0L × 2 (0.5 gal. × 2)	
	Hydraulic oil tank		50.3L (13 gal.)	
	Sprinkler tank		1,000L (264 gal.)	
Others	Instruments and lights		1 set	

SPECIFICATIONS

1-3. SW770ND

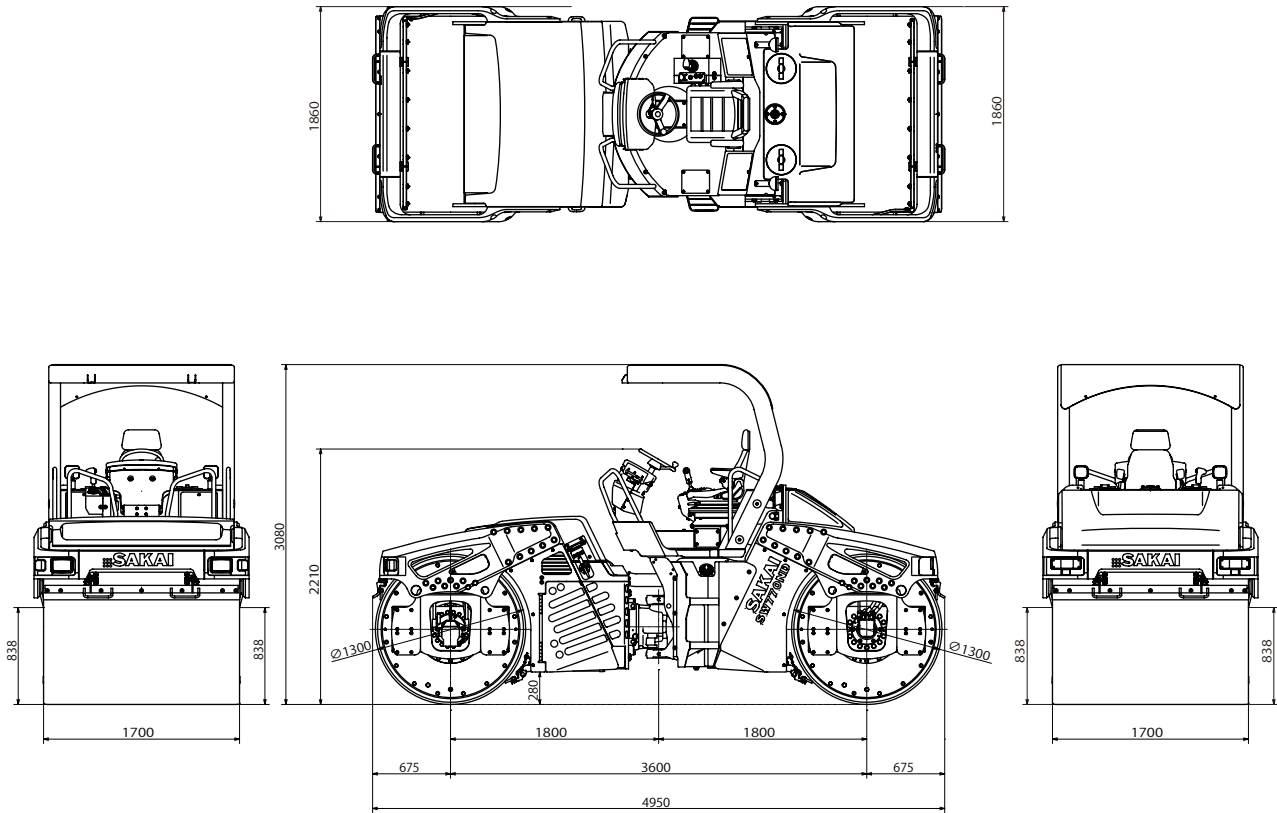

0431-99015-0-10579-A

Model		SW770ND	
Weight	Operating weight		11,320 kg (24,955 lbs.)
	Front axle		5,460 kg (12,035 lbs.)
	Rear axle		5,860 kg (12,920 lbs.)
Dimensions	Overall length	Frame	4,950 mm (195 in.)
	Overall width	Frame	1,860 mm (73 in.)
	Overall height	Steering wheel	2,210 mm (87 in.)
		ROPS	3,080 mm (121 in.)
	Wheelbase		3,600 mm (142 in.)
	Compaction width		1,700 mm (67 in.)
	Minimum height above ground		280 mm (11 in.)
	Curb clearance		838 mm (32.5 in.)
Speed	Forward/reverse		0 to 12 km/h (0 to 7.5 mph)
Vibration performance	Frequency	Vibration	50 Hz
		Oscillation	50 Hz
	Centrifugal force	Vibration	155 kN (34,845 lbs.)
		Oscillation	162 kN (36,420 lbs.)
	Amplitude	Vibration	0.65 mm (0.026 in.)
		Oscillation	0.70 mm (0.028 in.)
Minimum turning radius		6.3 m (249 in.)	
Gradability *1		26 % (15 °)	

*1: The gradability is the calculated value. It may vary based on the ground surface conditions.

Engine	Name		ISUZU 4JJ1XDIA diesel engine (EPA Tier 3) with turbocharger
	Model		Water-cooled, 4-cycle, 4-cylinder in-line, overhead camshaft, direct-injection type, with turbocharger
	Number of cylinders - Bore × Stroke		4-95.4 mm × 104.9 mm (4-3.756 in. × 4.130 in.)
	Displacement		2.999L (183 cu.in)
	Performance	Rated speed	2,200 min ⁻¹ (2,200 rpm)
		Rated output	92 kW (123 HP)
		Max. torque	420 N·m (310 lbf·ft) ----- at 1,800 min ⁻¹
		Fuel consumption	206 g/kW·h (0.339 lb/HP·h) ----- at rated speed with silencer and air cleaner, without cooling fan
	Fuel injection system		Full electronic control
	Fuel injection pump		Common rail HP3 TYPE
	Lubrication system		Full forced pressure feed type
	Oil filter		Full flow paper element
	Oil cooler		Pressurized water forced circulation type
	Air cleaner		Dry type
	Cooling system		Centrifugal pump forced feeding system (pressure type)
	Cooling fan		Inhaling type
Electrical system	Alternator	24 V 50 A	
	Starter	24 V 4.0 kW	
	Battery	12 V 80 Ah × 2 pcs. (24 V)	
Power line	Transmission	Type	Hydrostatic transmission
		Speeds	2 speed shifts
	Reverser	Switching the direction of flow delivered from the variable pump	
Final drive		Planetary gear	
Vibrating system	Transmission		Hydrostatic transmission
	Vibrator		Twin eccentric shaft type
Braking device	Service brake		Hydrostatic and mechanical, multi-wet disc type
	Parking brake		Mechanical, multi-wet disc type
Steering system			Hydraulic type (Articulated type)
Drums	Use	Front drum	Vibration and driving × 1
		Rear drum	Vibration and driving × 1
	Dimension (width × dia.)	Front drum	1,700 mm × 1,300 mm (67 in. × 51 in.)
		Rear drum	1,700 mm × 1,300 mm (67 in. × 51 in.)
	Suspension system	Front drum	Rubber damper type
		Rear drum	Rubber damper type
Water spray system			Pressurized type
Fluid capacity	Cooling water		15L (4.0 gal.)
	Fuel tank		193L (51 gal.)
	Engine oil pan		14L (3.7 gal.)
	Vibrator case		45L × 2 (12 gal. × 2)
	Wheel motor gear case		2.0L × 2 (0.5 gal. × 2)
	Hydraulic oil tank		50.3L (13 gal.)
	Sprinkler tank		1,000L (264 gal.)
Others	Instruments and lights		1 set

2. TIGHTENING TORQUE CHART

N·m	(lbf·ft)
-----	----------

	Nominal Dia.	Pitch	Strength Classification							
			6.8		8.8		10.9		12.9	
Metric coarse screw	5	0.8	4.9	(3.6)	5.9	(4.4)	7.8	(5.8)	7.8	(5.8)
	6	1.0	7.8	(5.8)	9.8	(7.2)	13	(9.6)	13	(9.6)
	8	1.25	17	(13)	23	(17)	31	(23)	31	(23)
	10	1.5	39	(29)	49	(36)	59	(44)	59	(44)
	12	1.75	69	(51)	78	(58)	108	(80)	108	(80)
	14	2.0	98	(72)	127	(94)	167	(123)	167	(123)
	16	2.0	157	(116)	196	(145)	265	(195)	265	(195)
	18	2.5	196	(145)	245	(181)	343	(253)	343	(253)
	20	2.5	294	(217)	392	(289)	539	(398)	539	(398)
	22	2.5	441	(325)	539	(398)	686	(506)	686	(506)
	24	3.0	539	(398)	637	(470)	883	(651)	883	(651)
	27	3.0	785	(579)	981	(724)	1324	(977)	1324	(977)
30	3.5	1079	(796)	1324	(977)	1765	(1302)	1765	(1302)	
Metric fine screw	10	1.25	39	(29)	49	(36)	69	(51)	69	(51)
	12	1.25	69	(51)	88	(65)	118	(87)	118	(87)
	14	1.5	108	(80)	137	(101)	186	(137)	186	(137)
	16	1.5	167	(123)	206	(152)	284	(209)	284	(209)
	18	1.5	245	(181)	294	(217)	392	(289)	392	(289)
	20	1.5	343	(253)	441	(325)	588	(434)	588	(434)
	22	1.5	490	(361)	588	(434)	785	(579)	785	(579)
	24	2.0	588	(434)	735	(542)	981	(724)	981	(724)
	27	2.0	834	(615)	1030	(760)	1422	(1049)	1422	(1049)
	30	2.0	1177	(868)	1422	(1049)	1961	(1446)	1961	(1446)

ENGINE REMOVAL AND INSTALLATION

1. PRECAUTIONS FOR REMOVAL AND INSTALLATION

- When removing or installing the engine, observe the general precautions described below.
- 1) Precautions for removal work
 - Coolant that contains antifreeze should be treated as a chemical, and must not be drained carelessly on the ground.
 - To prevent dust from getting into disconnected hoses and tubes, cover them with a plug or similar means.
 - When draining oil, use a receptacle with sufficient capacity to receive it.
 - Before proceeding with the work, look for matchmarks that show the installation location. For reassembly, place matchmarks in the required locations to prevent errors. Then remove.
 - When disconnecting wiring connectors, hold the connector components so that unreasonable force is not applied to the wires.
 - Label wires and hoses to ensure correct installation location.
 - Confirm the number and thickness of shims prior to storage.
 - When lifting parts, use lifting equipment of sufficient capacity.
 - When separating parts by using pull bolts, tighten the bolts alternately.
 - Before removing a unit, clean its surrounding area. Then after removal, cover it to prevent dust and other substances from getting in.
 - Before removing piping for hydraulic oil or coolant, or removing related parts, satisfactorily release internal pressure.
 - 2) Precautions for installation work
 - Tighten bolts and nuts (sleeve nuts) to the specified torque (screw tightening torque table).
 - When installing hoses, do not twist them or allow them to interfere with other parts.
 - Replace gaskets, O-rings, split cotter pins, and lock plates with new parts.
 - Properly bend split cotter pins and lock plates.
 - When applying an adhesive, first clean and remove oil/grease from the surfaces properly. Then apply two or three drops to the threaded areas.
 - When applying a liquid gasket, first clean and remove oil/grease from the application surface properly, and confirm that the surface is free of dust and damage. Then apply the product evenly.
 - Clean parts well. Repair scratches, dents, burrs, rust, etc.
 - Apply gear oil to rotating and sliding components.
 - Apply grease to the surfaces of press-fit parts.
 - After installing snap rings, confirm that they are properly seated in the grooves.
 - Connect wiring connectors securely after cleaning off adhering oil, dust and water.
 - Use lifting bolts that are not fatigued or deformed. Screw them in fully.
 - When tightening a split flange, tighten screws alternately to prevent uneven tightening.
 - Before installing hydraulic parts, confirm that they are free of damage and dust, etc.
 - 3) Precautions when work is completed
 - If coolant has been drained, securely retighten the drain cock and fill with coolant (mixing in long-life coolant) to the specified level. Start the engine and allow the coolant to circulate through the piping. Then add coolant again to the specified level.
 - If hydraulic equipment has been removed and reinstalled, fill with hydraulic oil to the specified level. Start the engine and allow the oil to circulate through the piping. Then add oil again to the specified level.

2. ENGINE REMOVAL

Time of procedures:

- To remove engine takes about 3.5 hour × 2 people
- To install the engine takes about 6 hours × 2 people

Tools and equipment you need:

- Box (10 mm, 12 mm, 13 mm, 17 mm, 19 mm, 24 mm)
- Ratchet – big and small
- Nippers
- Screw Driver – “Phillips” big and small, “flat” big
- 10mm Box driver
- Spanner (10 mm, 13 mm, 14 mm, 17 mm, 19 mm – 2 units, 36 mm, 41 mm)
- Wrench (22-24, 17-19) mm
- Handle bar
- Pail can – Tank for hydraulic oil
- Wire
- Jack
- Cap for hydraulic hose (41, 3/4* 36, 1/2* 27)

2-1. Left and Right Side Cover Removal

- Uninstall left and right side cover.
(7 bolts, 17 box); 2 people



- Uninstall 2 small and 1 big cover under radiator. (17 box)

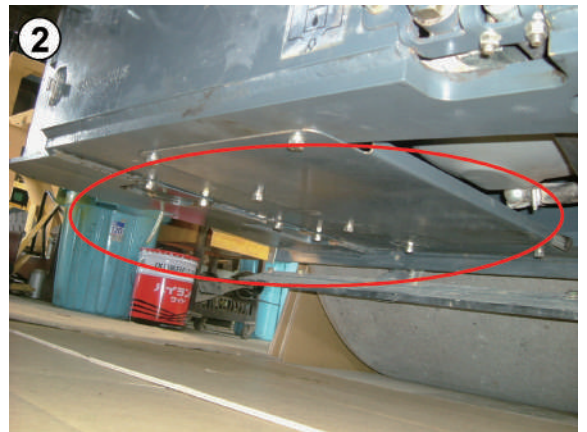

- Uninstall left cover. (17 box)



- Remove engine coolant. Open up valve.
(Capacity 12 L. Proportion 50:50)

Right open



2-2. Radiator Removal (Step 1)

- Remove coolant tank with hose.



Remove cleaner hose. (10 box)



- Uninstall hoses connected to radiator except oil hose.
Intake hose 10 box + screw driver
Coolant hose 10 box + screw driver

CAC hose



2-2. Radiator Removal (Step 2)

Uninstall CAC hose.



Uninstall hose connected to upper part of radiator.



Oil cooler hose uninstall. (36 spanner)



Install the cap.



2-2. Radiator Removal (Step 3)

(NOTICE)

- Oil cooler hose is connected with oil tank. Please use vacuum effect or put cap for oil hose to avoid oil leakage from the hose.

2100-12020-1, 4 bolts

2100-12020-1, 4 bolts



- Remove plate. 5 bolts. (17 box)



Move radiator to make a space to remove oil cooling hose. 36 spanner.



Put a cap to protect hose and radiator oil input and remove the radiator. (2 people)



2-3. Fan and Air Cleaner Removal

Unscrew 4 bolts. (12 mm box)



Correct position of fan.



Priority – order of fan elements

Remove clamp of air cleaner.
(17 mm spanner)

Unscrew hose clamp. (13 mm box)

Use "flat" screw driver.

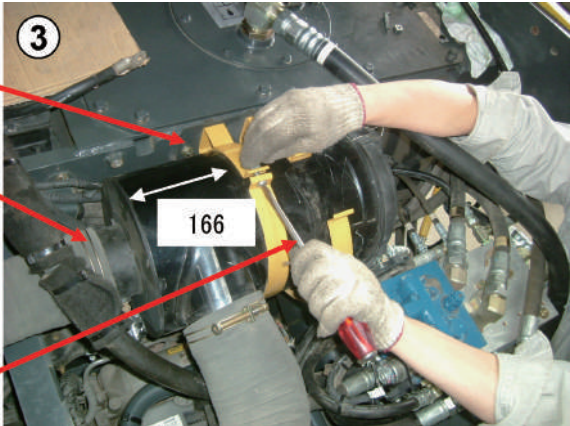

Keep this configuration of hose and air cleaner.



2-4. Battery Relay; Bracket Removal

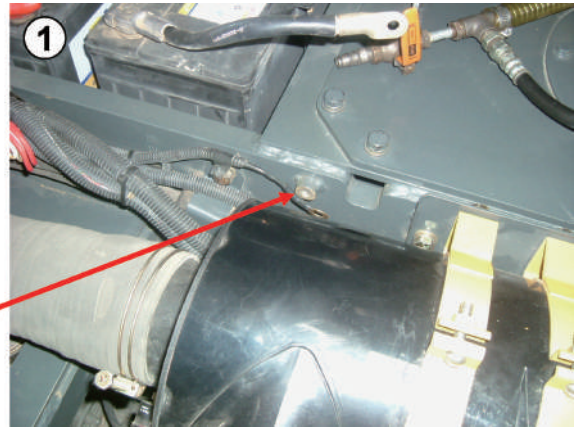

Unscrew 2 earth cables. (13 box)



Unscrew battery cable "positive".
(14 spanner)



Remove battery relay with bracket.
(17 box)



Put electric wires in a safe position.
Prepare isolation.

2-5. Engine Hoses Removal

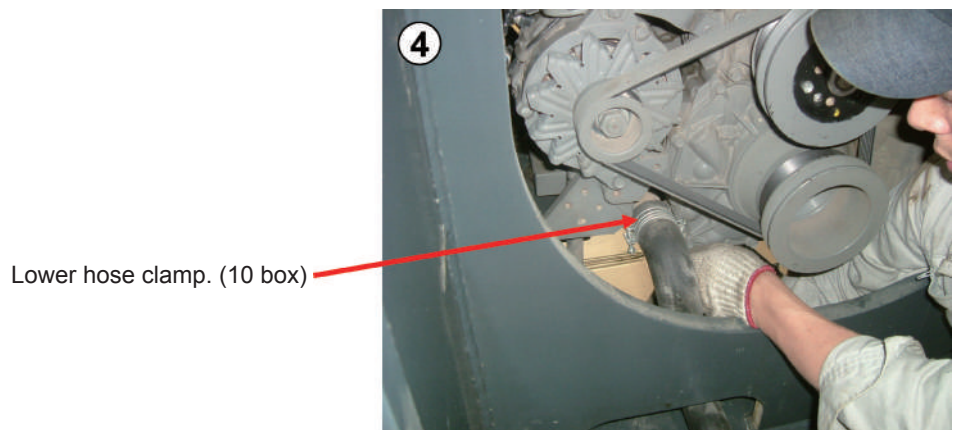
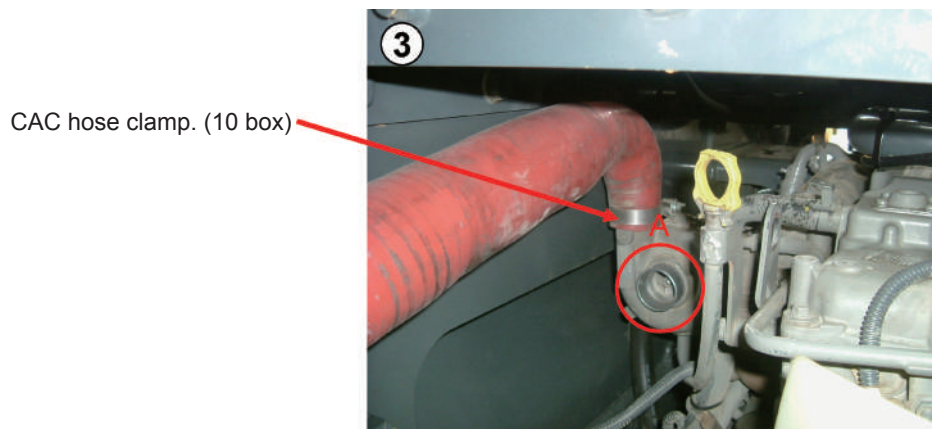
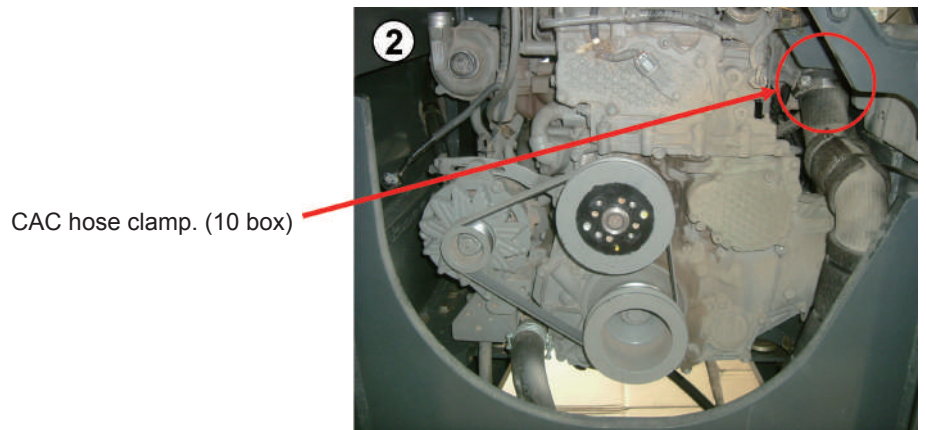
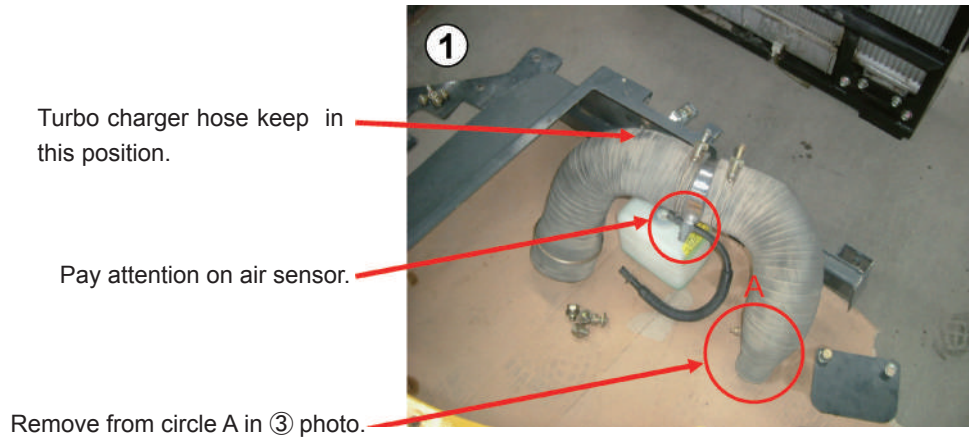

2-6. Support Frame Removal

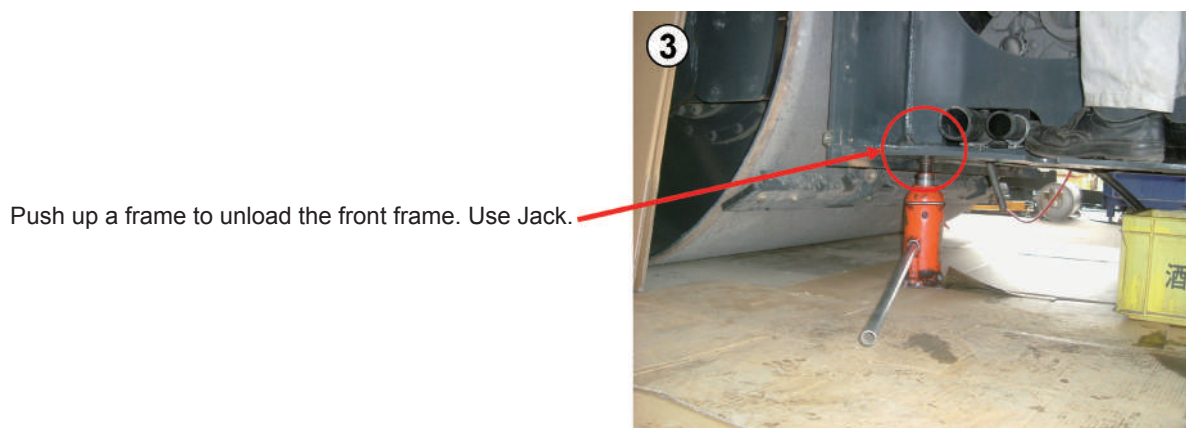
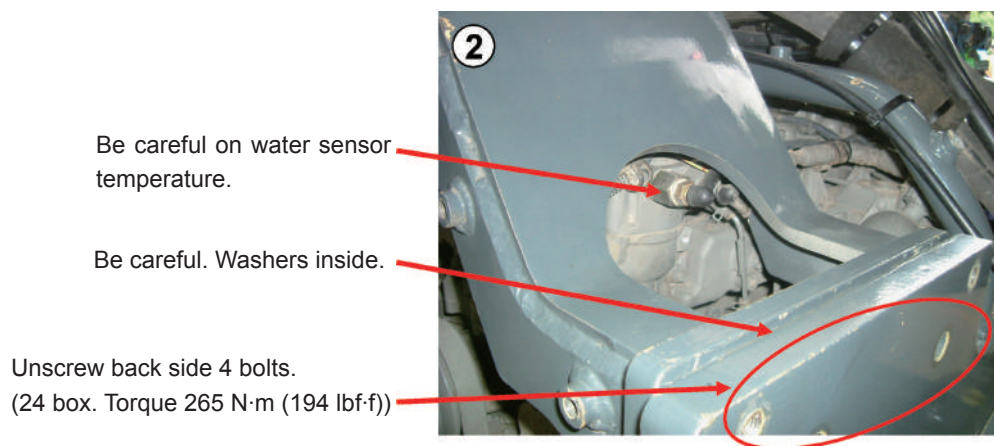
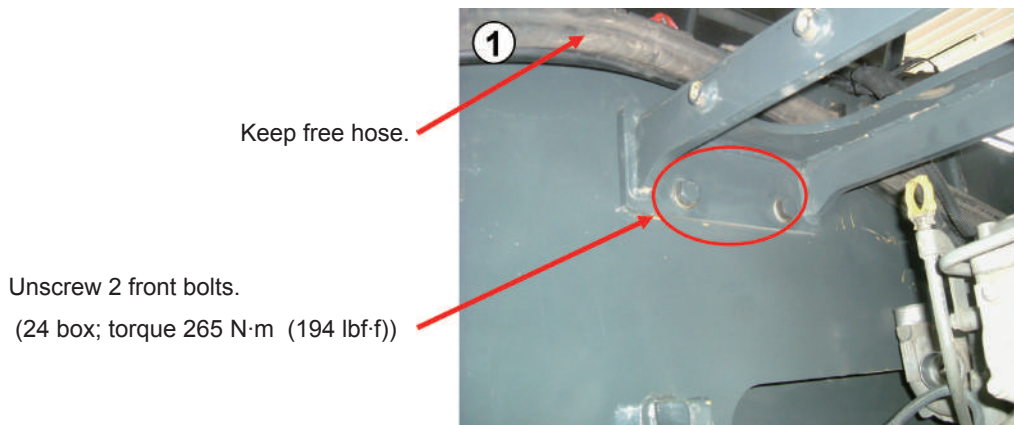

- Lift up a little bit upper frame and take out bolts and remove the frame.



2-7. Hydraulic Hose Removal

Disconnect vibration pressure oil hose and put cap.
(36 Spanner)

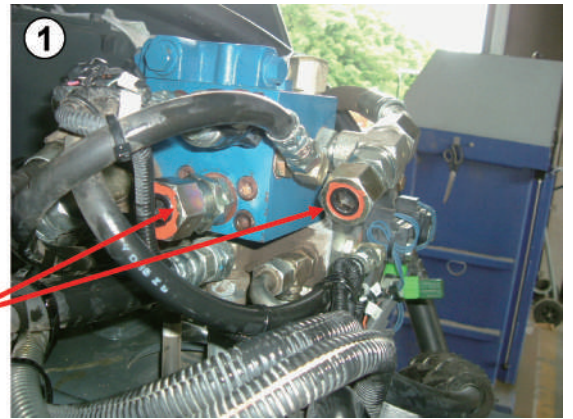

Remove 2 clamp hose brackets.

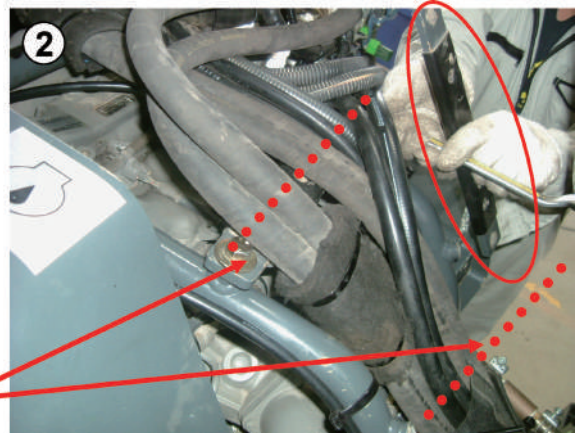

Remove pipe frame above the engine.
4 bolts. (19 box)

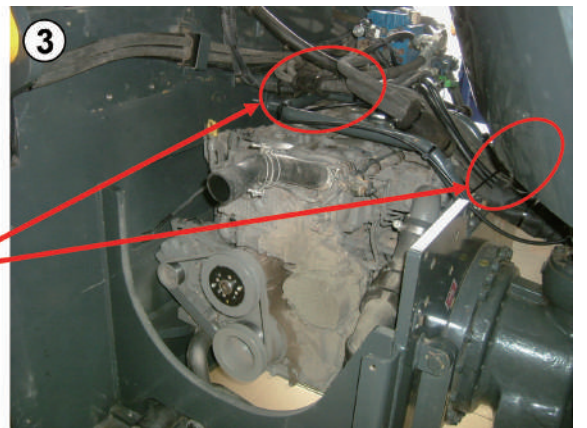

Need two people for this operation.

Lift up hydr. and elect. hoses and remove carefully
pipe frame from below.



2-8. Exhaust System Removal

Unscrew 4 bolts. (17 box)

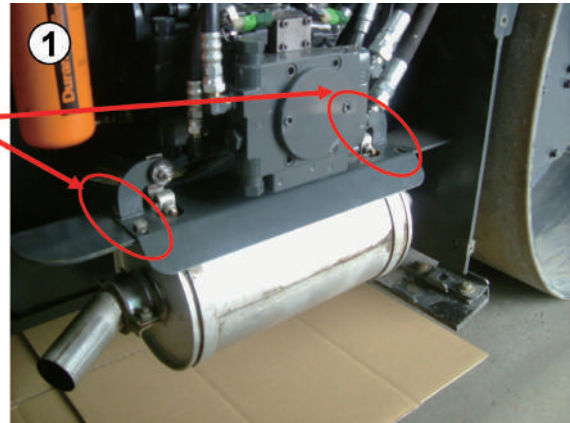

Make loose of the clamp and remove exhaust pipe.

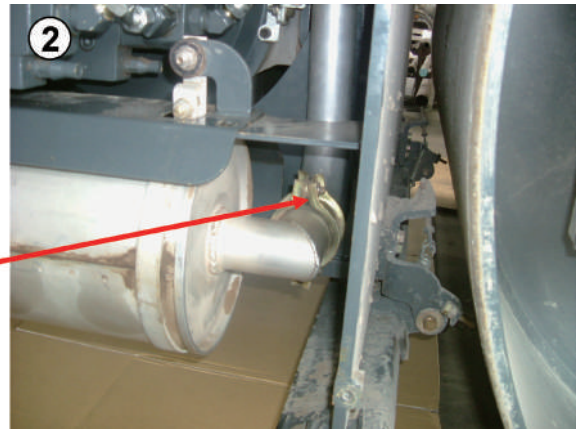

Remove clamp. (17 box and wrench)

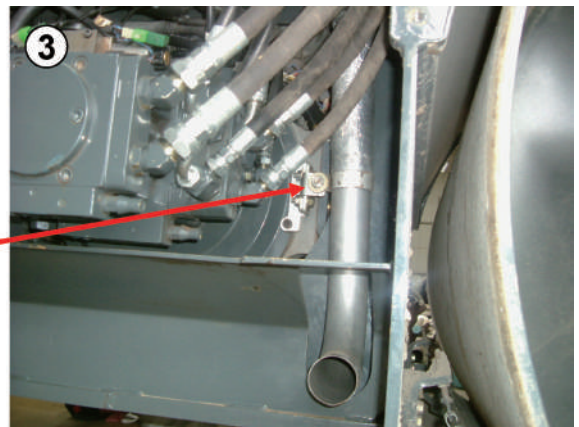

Unscrew 3 nuts of exhaust pipe and rotate the pipe remove it from the machine.



2-9. Main Hydraulic Pump Removal

Remove carefully cables.
(10 box, spanner, 19 spanner × 2).

Unscrew and push aside
electric harness.

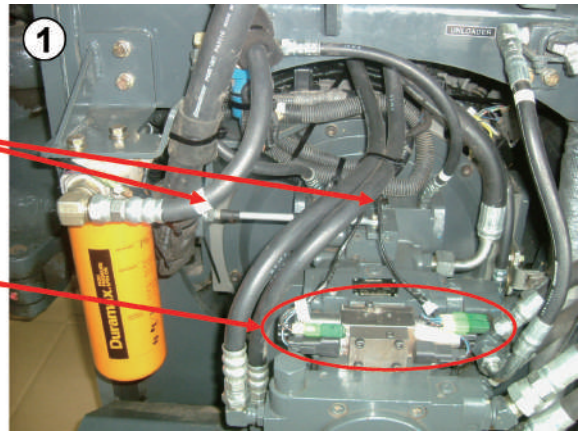

- Unscrew main hydr. pump. (use 24 – 22 wrench. 24 box and handle bar)

Do it with two people.

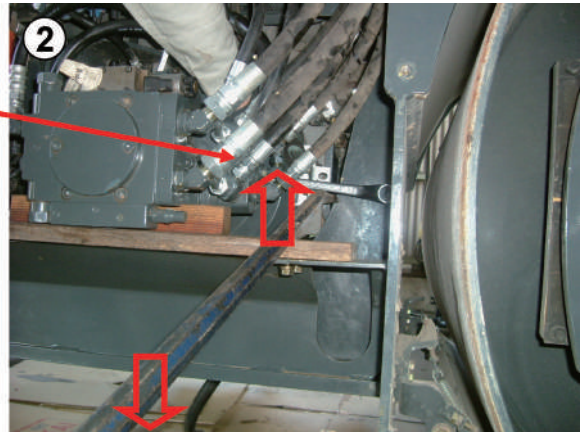

Fix pump and hoses by ropes.

Use wood block and put under
the pump as a base.

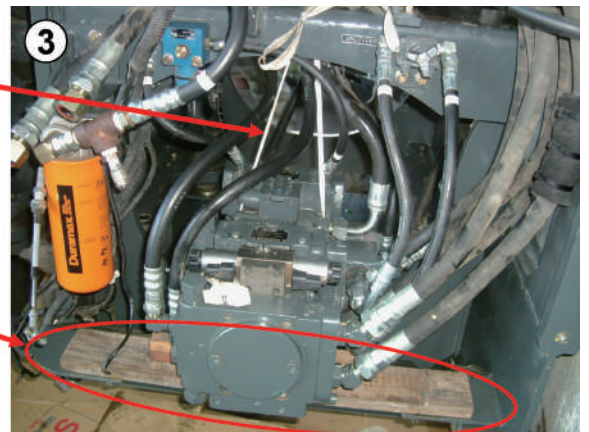

Remove cable bracket from the engine.



2-10. Bolts and Hoses Removal

(NOTICE)

- Remove below bolts and hoses before removing engine.

Engine oil drain hose. (U bolt. 13 box)



Pay attention on hose.

Unscrew hose clamp. (13 box, 3 clamps.)

Engine earth cables. (19 box)

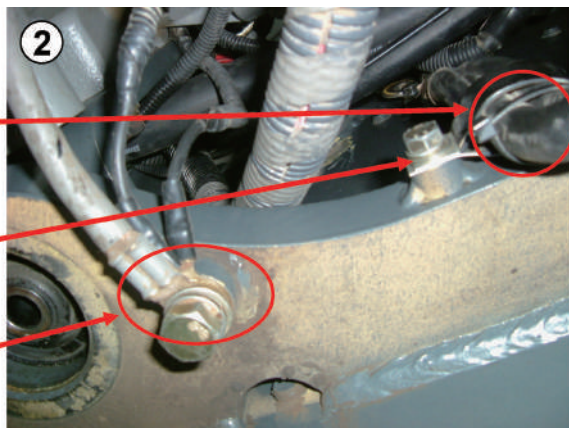

Starter cable. (13 spanner)

2 bolts are on the other side.

Engines 4 bolts.
(24 box. Torque 265 N·m (194 lbf·f))

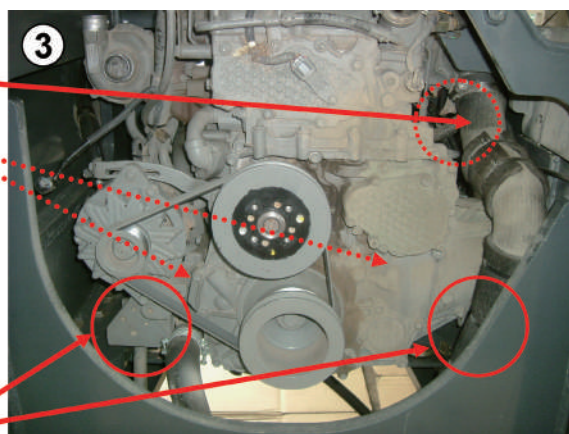

2-11. Hoses Removal

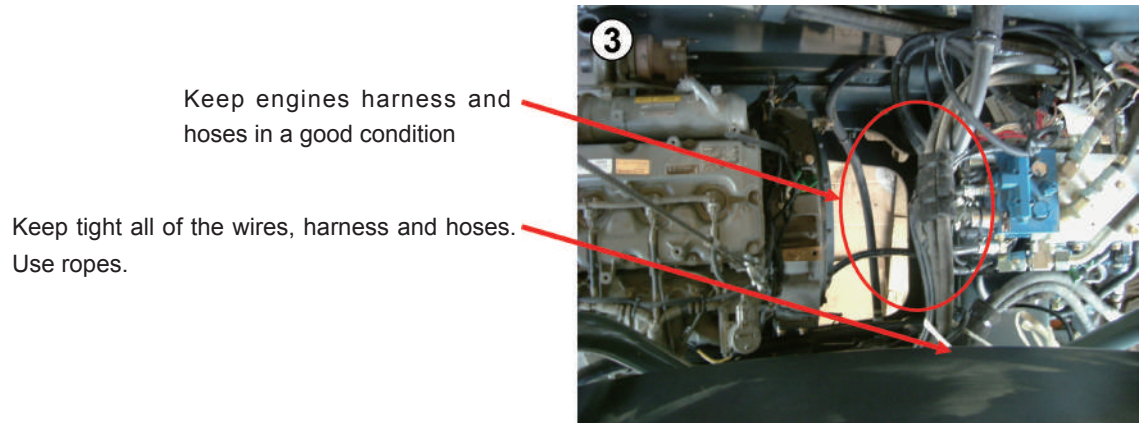
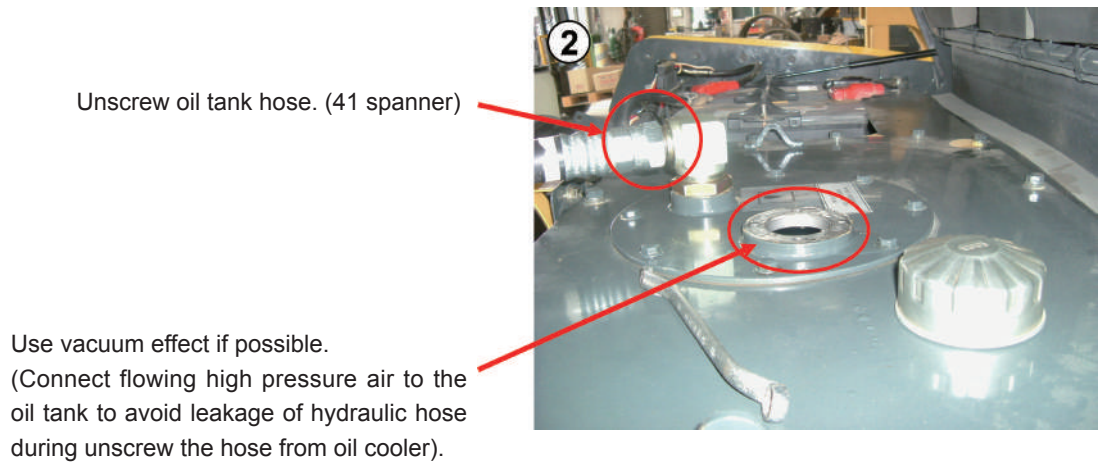
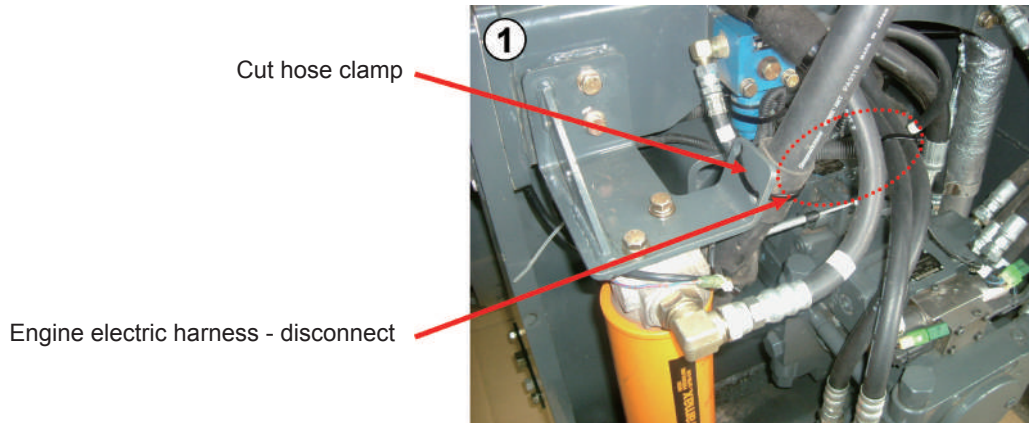

2-12. Engine Removal (Step 1)

Use crane. Fix 2 ropes in special lifting points.
Hydraulic Pump must be separate.



- Pay attention during lifting up the engine.

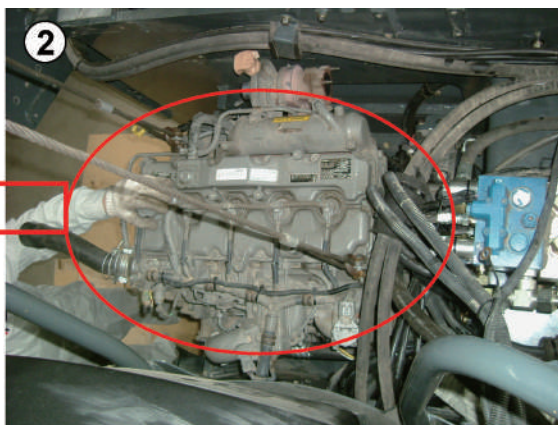

Pay attention on all cables, harness and hoses.



After you will lift up the engine, please remove
steering hydraulic hoses.

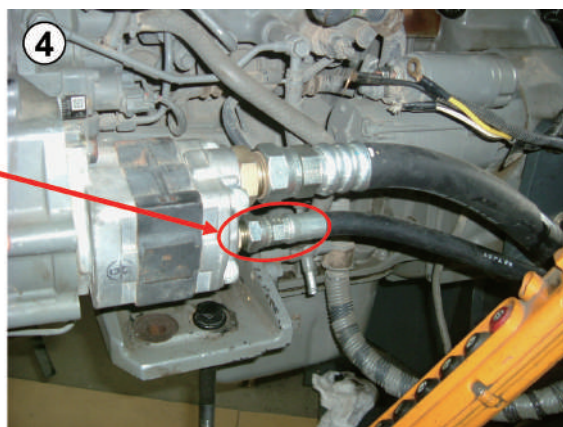

2-12. Engine Removal (Step 2)

Be careful to not hit engine to front bracket frame.

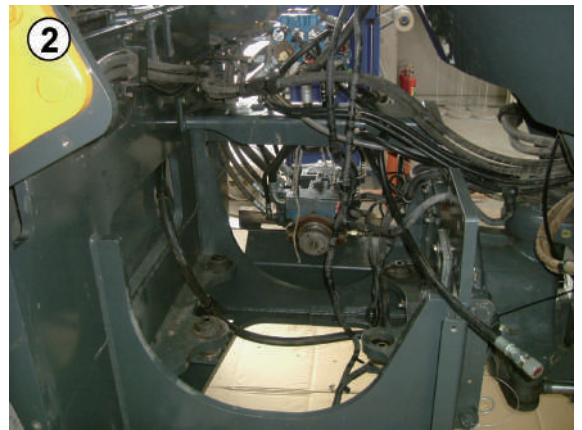

- Keep fuel hose clean. Protect against dust.
- Keep clean other hoses.
- Protect engine intake system.



3. ENGINE INSTALLATION

Installation process of the engine is exactly opposite order of removing process.

SYSTEM CIRCUIT DIAGRAMS

1. HYDRAULIC CIRCUIT DIAGRAMS

1-1. SW770, 770ND

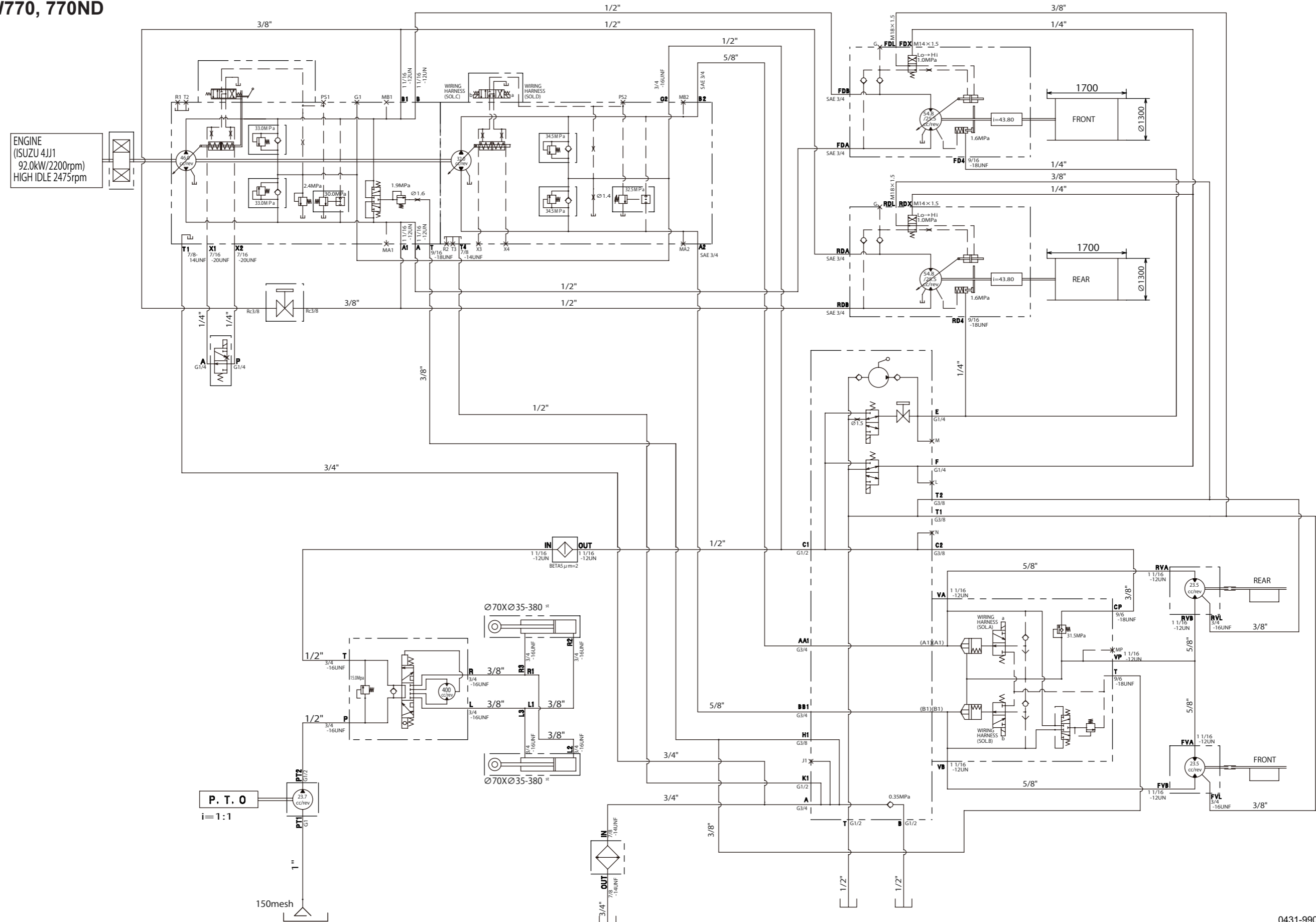

2. ELECTRICAL CIRCUIT DIAGRAMS

1-1. SW770, 770ND

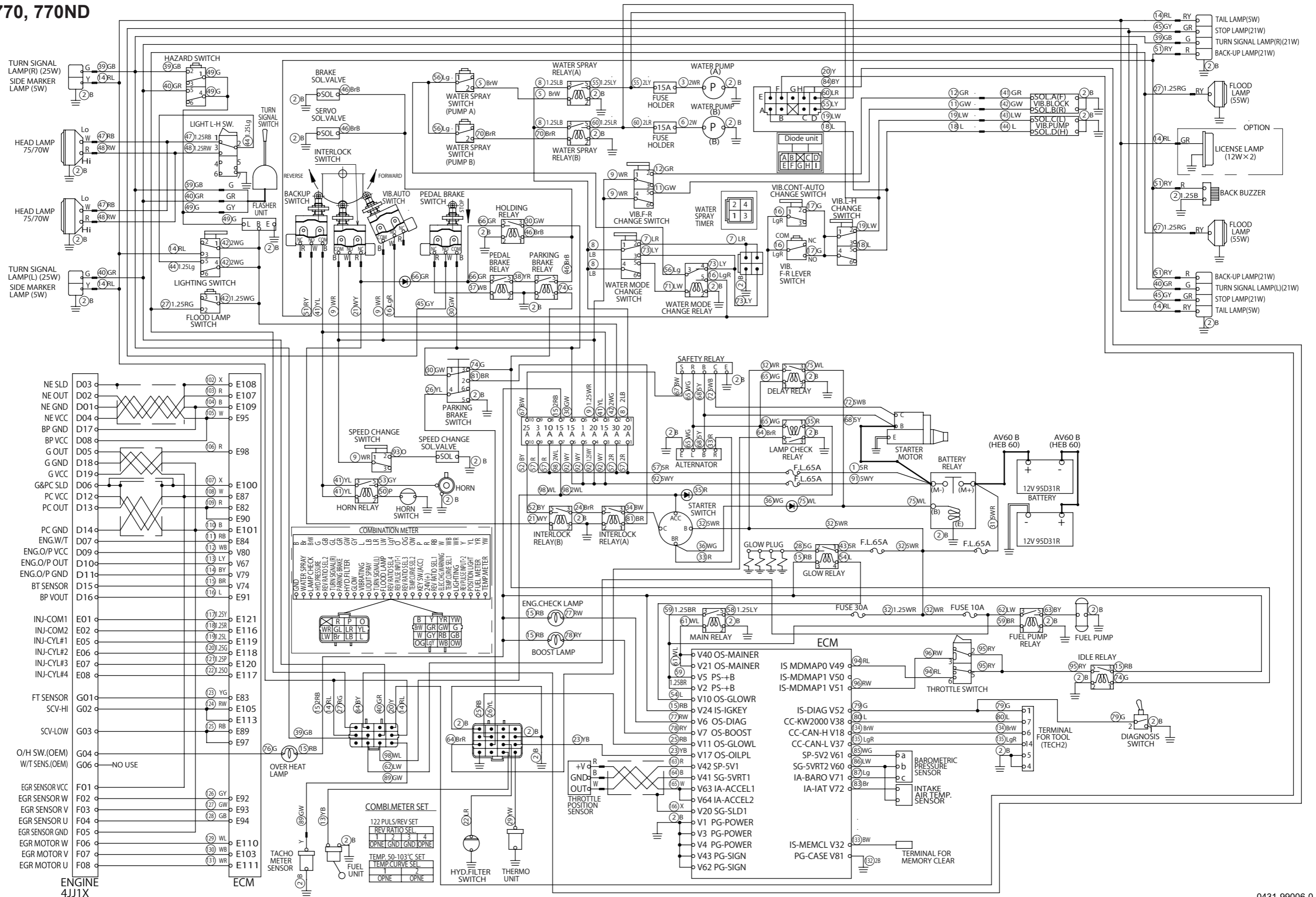

HYDRAULIC PUMP AND MOTORS LOCATION

1. LOCATION (1/5)

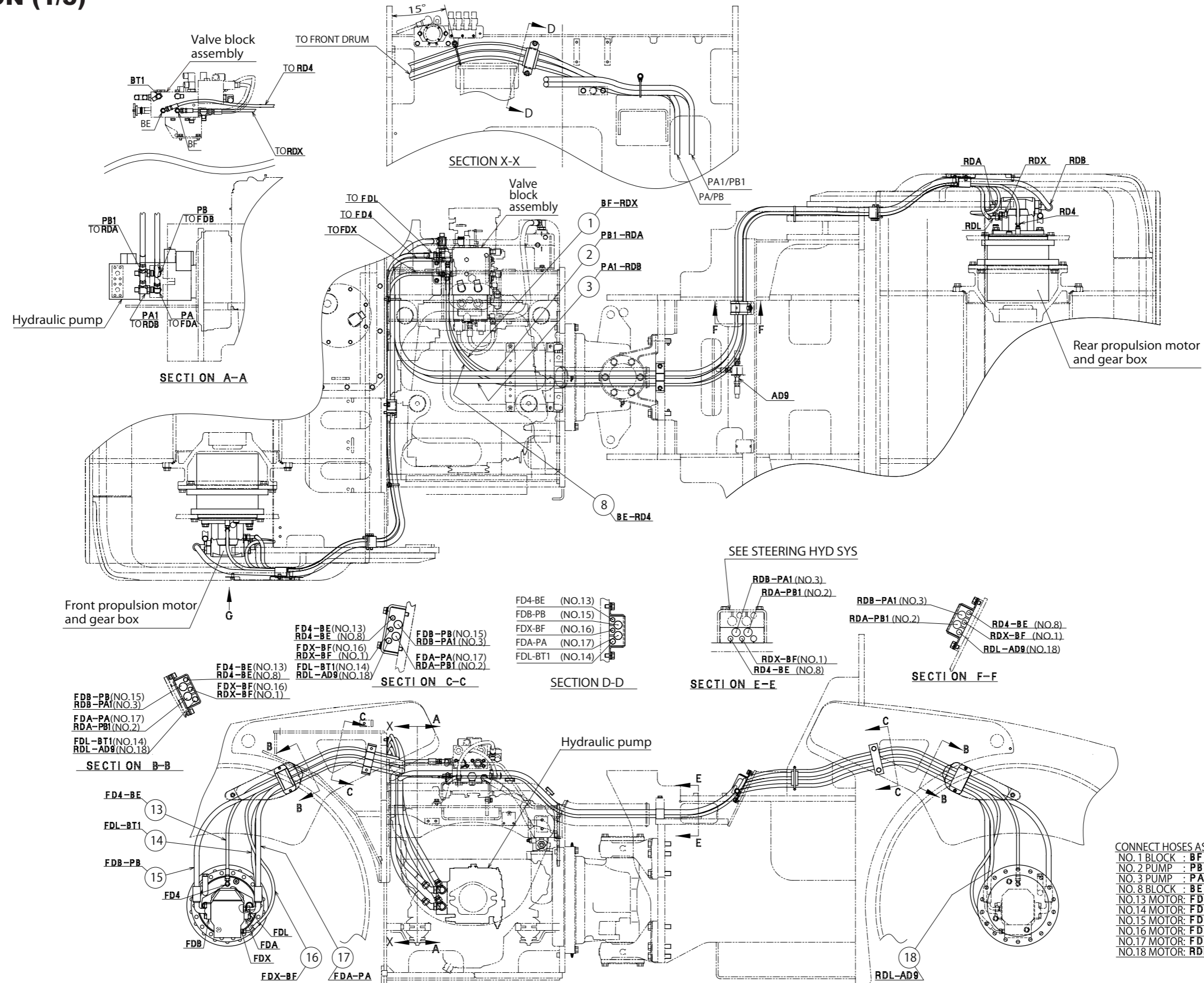

2. LOCATION (2/5)

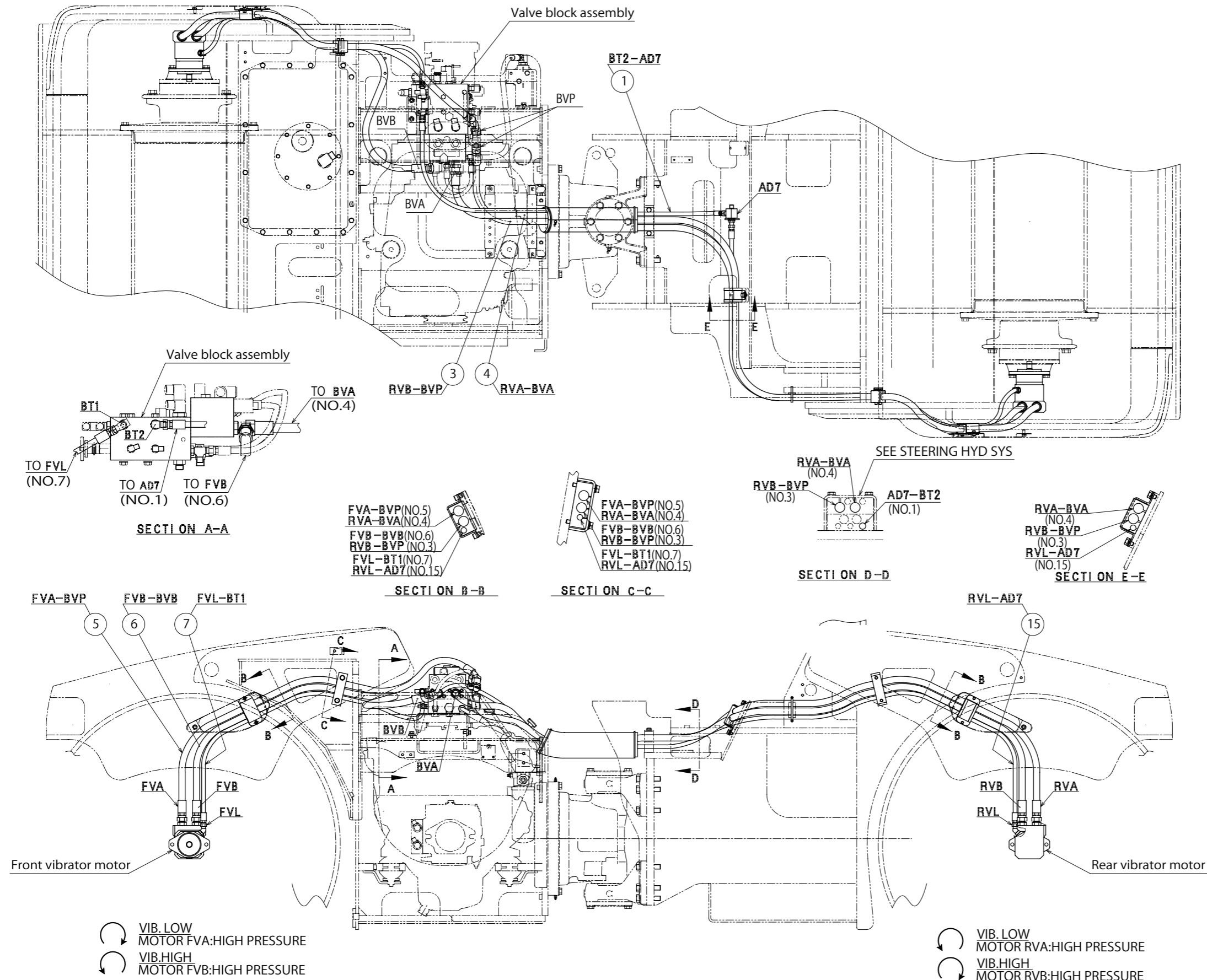

3. LOCATION (3/5)

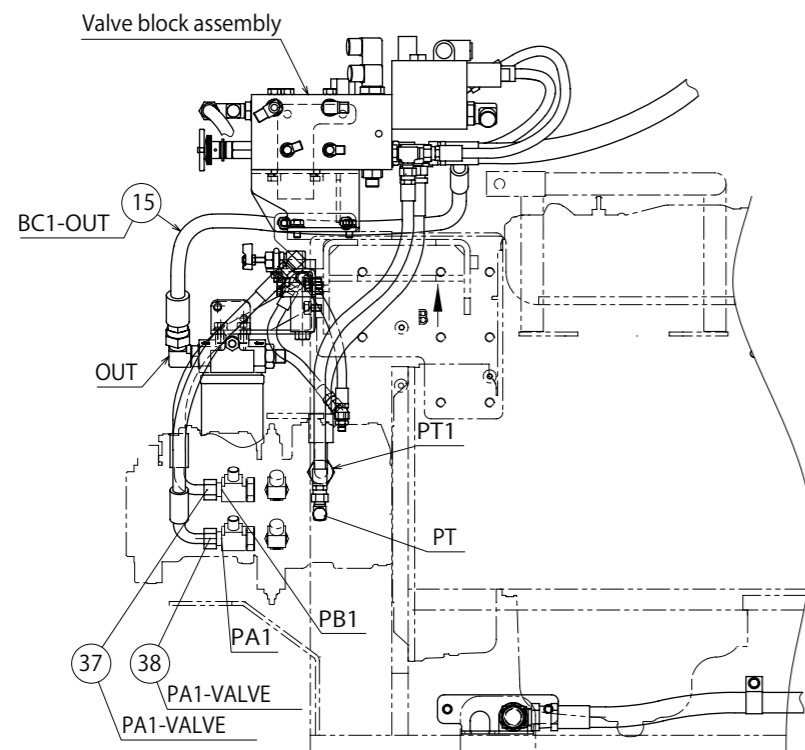
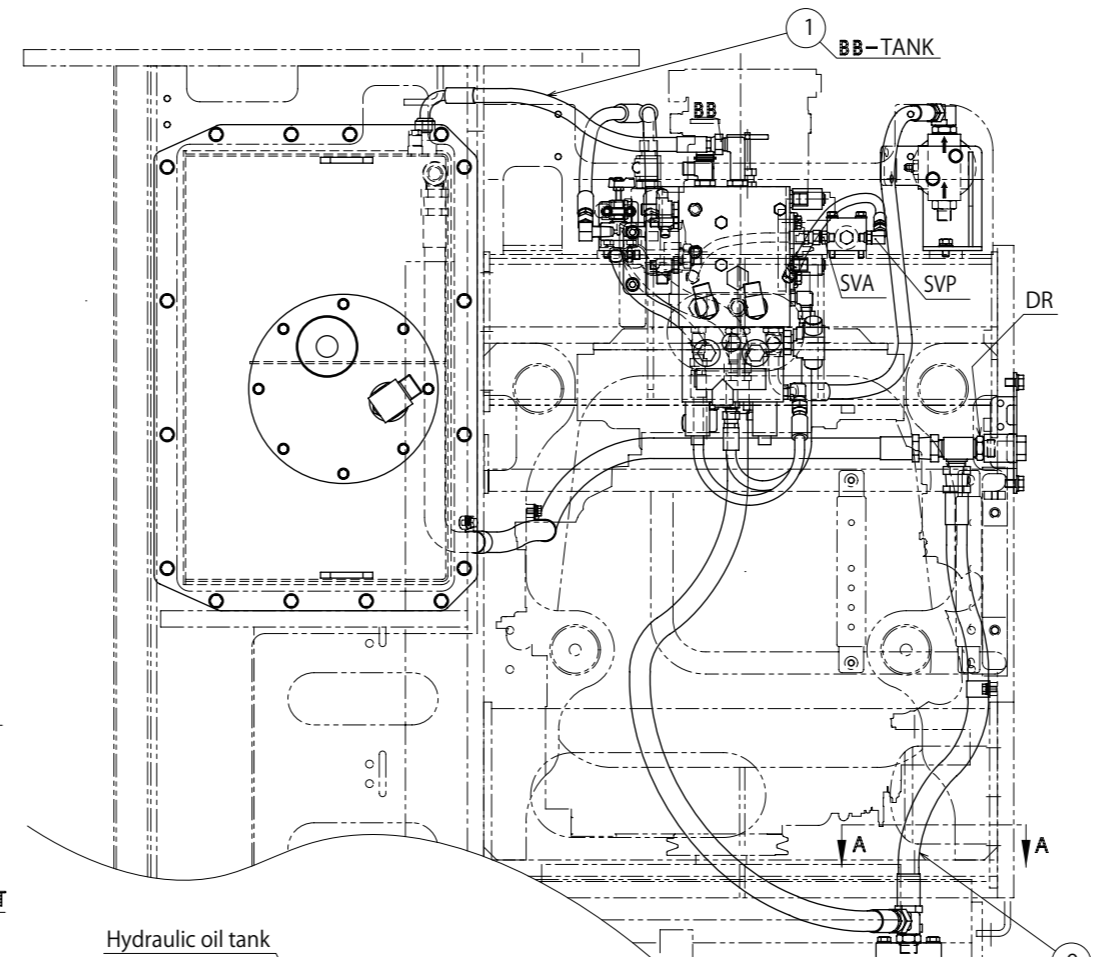
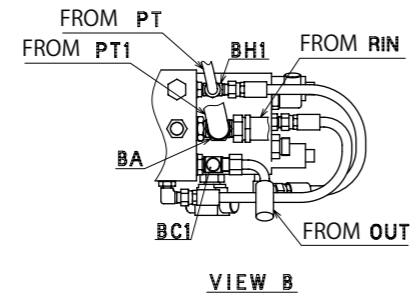
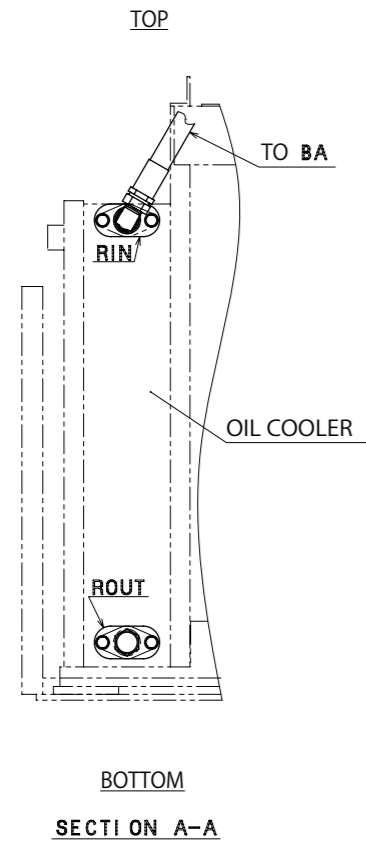

CONNECT HOSES AS FOLLOWS.

NO.1 BLOCK	: BB	⇔	TANK
NO.9 OIL COOLER	: ROUT	⇔	BRACKET : DR
NO.14 OIL COOLER	: RIN	⇔	BLOCK : BA
NO.15 BLOCK	: BC1	⇔	FILTER : OUT
NO.16 BYPASS VALVE	: SVP	⇔	PUMP : PX2
NO.17 BYPASS VALVE	: SVA	⇔	PUMP : PX1
NO.20 OIL COOLER	: ROUT	⇔	TANK
NO.37 PUMP	: PB1	⇔	UNLOADER VALVE
NO.38 PUMP	: PA1	⇔	UNLOADER VALVE
NO.39 BLOCK	: BA	⇔	PUMP : PT1
NO.40 BLOCK	: BH1	⇔	PUMP : PT

4. LOCATION (4/5)

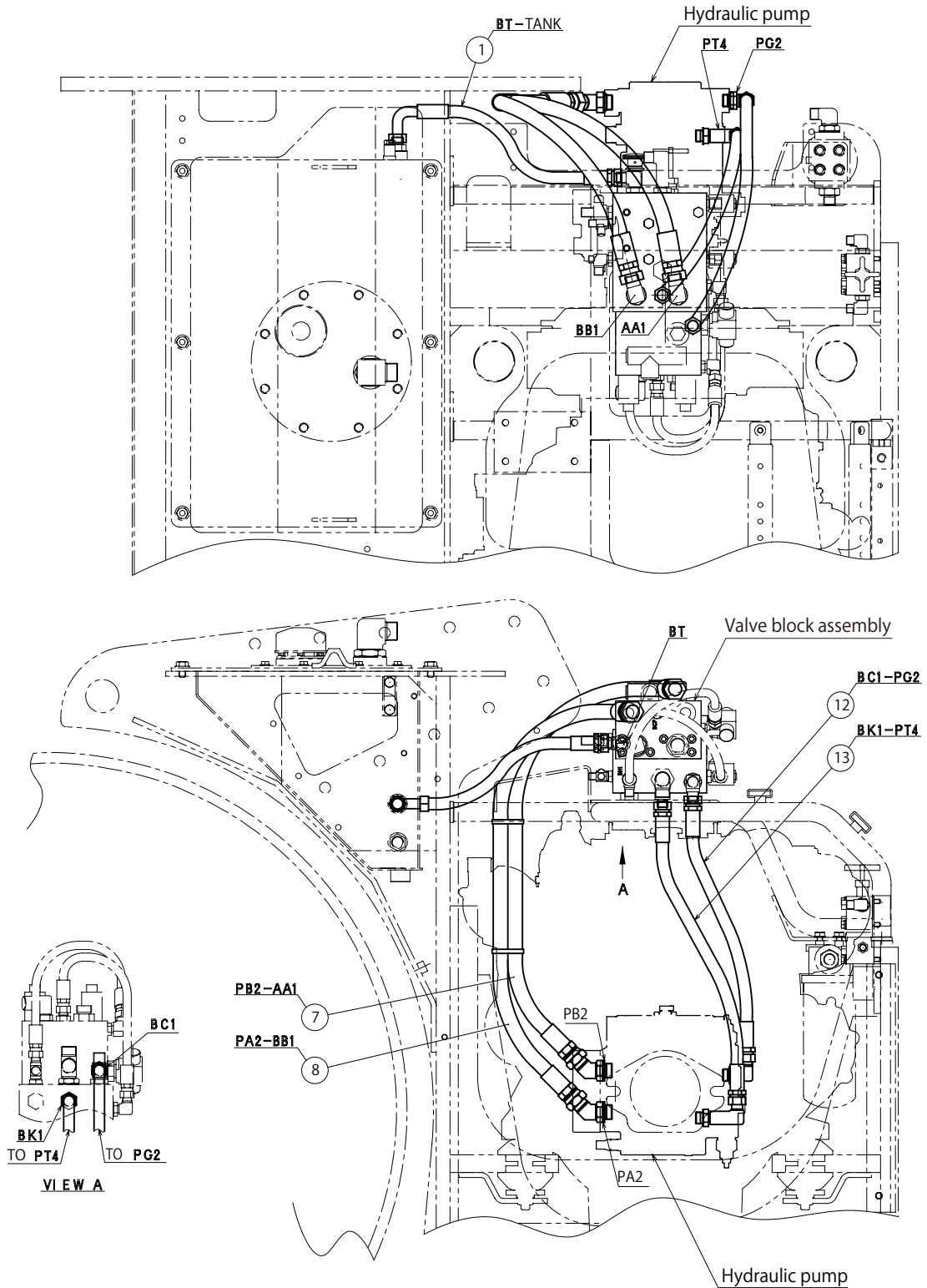

CONNECT HOSES AS FOLLOWS.

NO. 1 BLOCK	: BT	⇔	TANK
NO. 7 BLOCK	: AA1	⇔	PUMP : PB2
NO. 8 BLOCK	: BB1	⇔	PUMP : PA2
NO. 12 BLOCK	: BC1	⇔	PUMP : PG2
NO. 13 BLOCK	: BK1	⇔	PUMP : PT4

5. LOCATION (5/5)

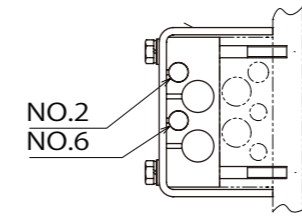
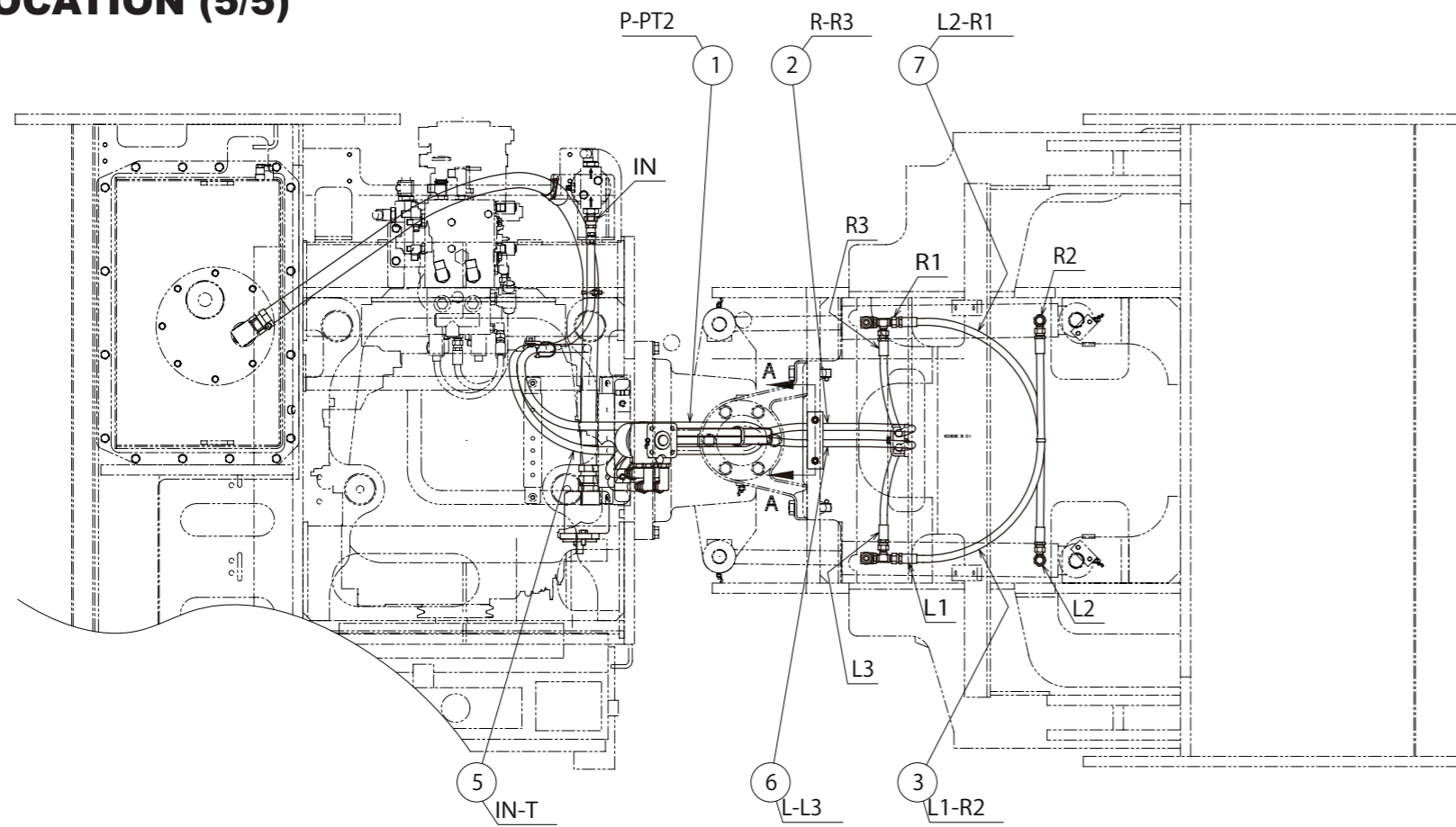

SECTION A-A

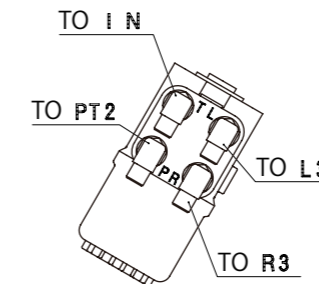
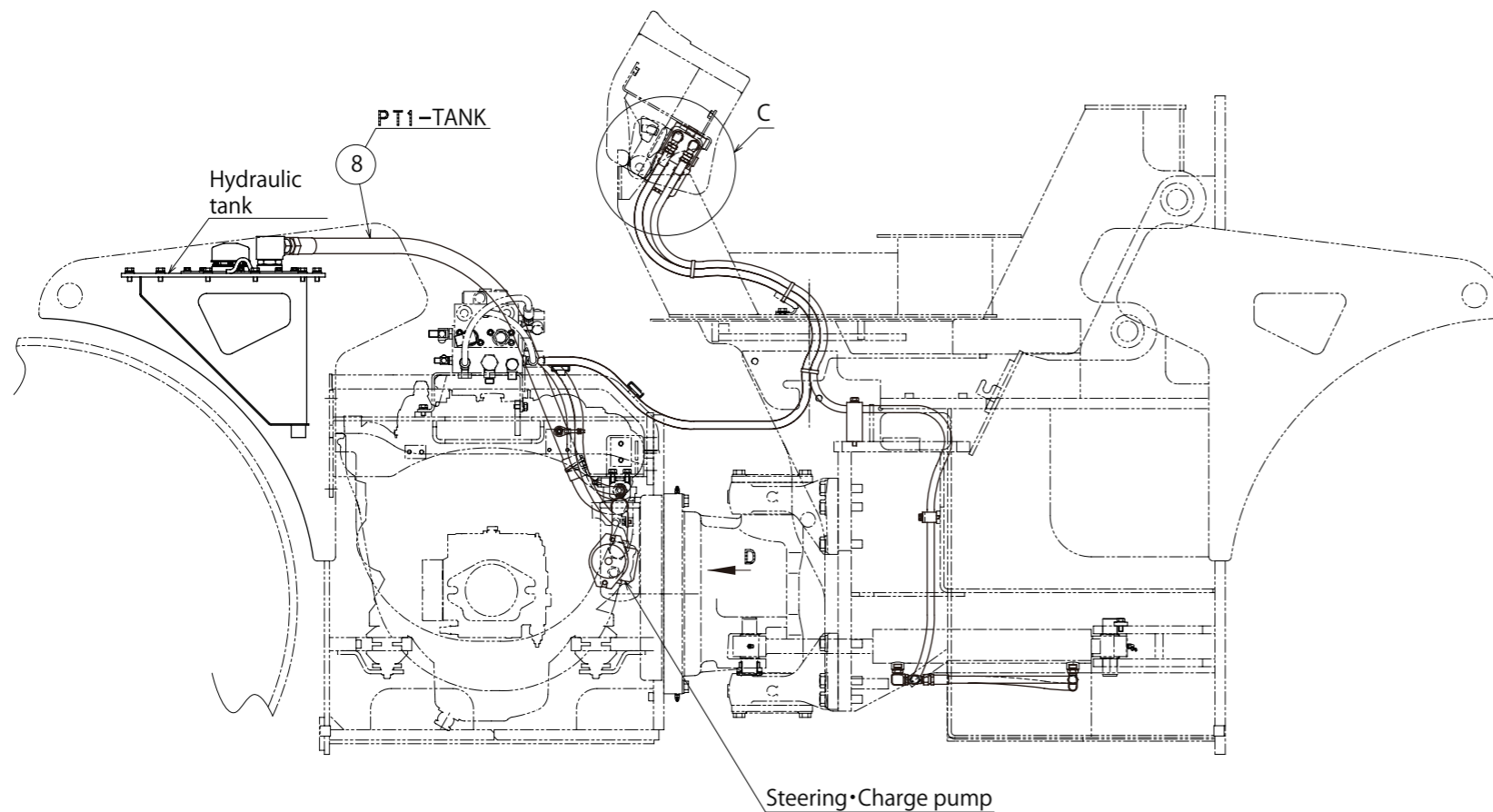

DETAIL L C

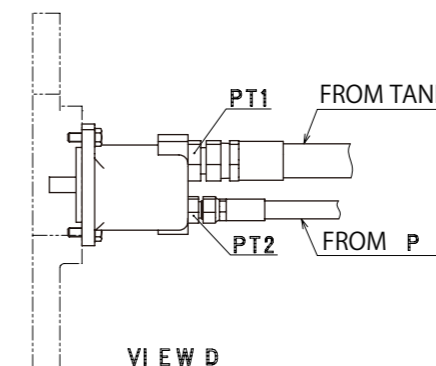

VIEW D

CONNECT HOSES AS FOLLOWS.

NO. 1 ORBITROL : P	⇔ PUMP	: PT2
NO. 2 ORBITROL : R	⇔ CYLINDER	: R3
NO. 3 CYLINDER : R2	⇔ CYLINDER	: L1
NO. 5 FILTER : IN	⇔ ORBITROL	: T
NO. 6 ORBITROL : L	⇔ CYLINDER	: L3
NO. 7 CYLINDER : L2	⇔ CYLINDER	: R1
NO. 8 PUMP : PT1	⇔ TANK	