

## PREFACE

This operator's manual serves as a guide for the use of your SAKAI SW880-1, SW990-1 Vibrating Roller for those who are new to the machine, and also for the people who have experience in using the machine and want to refresh their knowledge for the machine.

Read this manual thoroughly and try to fully understand the information before operating your machine. Keep this handbook at hand whenever you do your work.

When an instruction manual is lost or is damaged and is not legible, replace it immediately.

The main subjects of this manual are:

(1) Basic precautions for safety, (2) Operation, (3) Daily maintenance and (4) Specifications.

For operation and maintenance of the engine, refer to the Engine Instruction Manual furnished separately. Descriptions in this manual can differ from the machine instructions of your machine due to the results of the investigation and improvement in its design. If you have any inquiry regarding your Machine or this manual, contact our distributors.

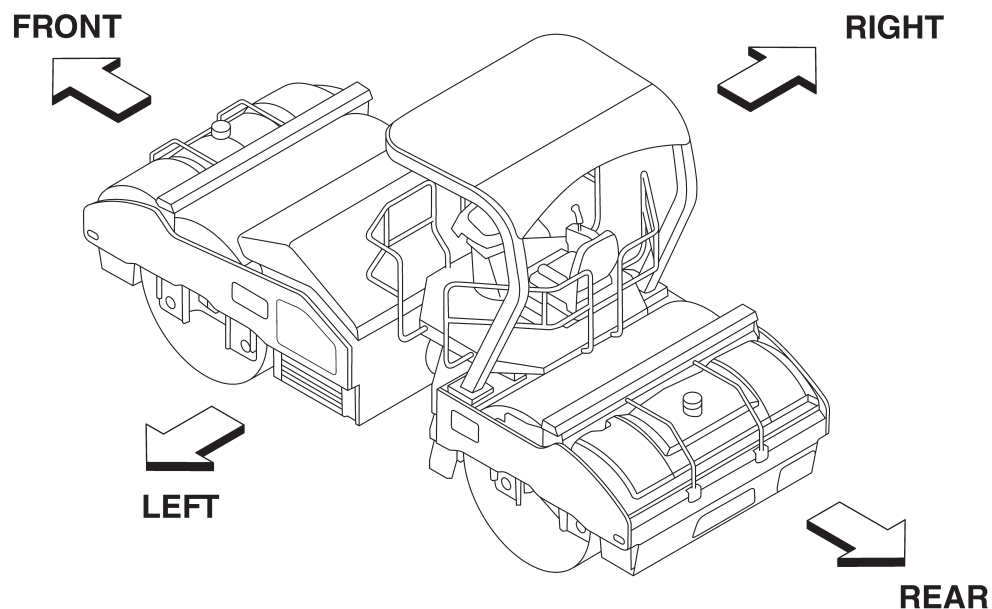

SW880-1, SW990-1

**CONTENTS**

## PREFACE

MACHINE AND ENGINE IDENTIFICATION NUMBERS ..... 1

SAFETY NOTICES ..... 2

**1 BASIC PRECAUTIONS FOR SAFETY ..... 4**

1.1 General Precautions..... 4

1.2 Preparation for Safe Operation ..... 8

1.3 Before Starting the Engine ..... 9

1.4 After Starting the Engine ..... 10

1.5 During Operation ..... 11

1.6 Loading and Unloading ..... 14

1.7 Transportation ..... 14

1.8 Handling the Battery..... 15

1.9 Towing..... 16

1.10 Before Servicing ..... 17

1.11 During Servicing ..... 19

1.12 Safety Decals ..... 22

**2 OPERATION..... 24**

2.1 Instruments and Controls ..... 24

2.1.1 Operator's station ..... 24

2.1.2 Gauges, indicator lamps and warning lamps..... 25

2.1.3 Switches ..... 29

2.1.4 Operating levers / pedals..... 37

2.1.5 Fuse box and Line fuse ..... 39

2.2 Handling and Adjustments ..... 39

2.2.1 Seat adjustment..... 39

2.2.2 Scraper adjustment and replacement..... 40

2.2.3 Disengaging the brake when towing..... 41

2.2.4 Steering wheel position adjustment ..... 42

2.2.5 Operator's platform position adjustment ..... 43

2.2.6 Step for maintenance of engine room ..... 43

2.2.7 Engine diagnoses ..... 44

2.3 Operation..... 45

2.3.1 Before-starting inspection ..... 45

2.3.2 Starting the engine..... 46

2.3.3 After starting the engine..... 47

2.3.4 Traveling ..... 48

2.3.5 Stopping and parking..... 51

2.3.6 AUTO SPEED..... 52

2.3.6.1 Setting..... 52

2.3.6.2 Canceling AUTO SPEED ..... 53

2.3.7 Stopping the engine..... 54

2.3.8 Check after stopping the engine ..... 54

2.4 Vibratory Operation ..... 55

2.5 Water Spray System ..... 57

2.6	EXACT COMPACT Operation (Impact Space Indicator & Speed Mater).....	60
2.6.1	Function .....	60
2.6.2	Operating instruction.....	60
2.6.3	Operation .....	62
2.7	Machine Controller Diagnoses .....	62
2.8	Precautions for Work.....	64
2.8.1	Compaction operation.....	64
2.8.2	When going downhill.....	64
2.8.3	On a slope .....	64
2.9	Applicable Jobs .....	64
2.10	After Operation .....	65
2.11	Loading and Unloading .....	66
2.11.1	Use of a trailer equipped with a winch .....	66
2.11.2	Self-propelling.....	67
2.12	After Loading the Machine .....	67
2.13	Transportation .....	68
2.14	Operation in Cold Weather.....	68
2.14.1	Fuel oil and grease .....	68
2.14.2	Coolant .....	68
2.14.3	Battery .....	70
2.15	When the Cold Season is Over .....	71
2.16	For a Long Storage Period .....	71
2.17	During the Storage Period.....	71
2.18	When the Battery has Discharged.....	72
2.18.1	Connection and disconnection of booster cables .....	72
3	PERIODIC MAINTENANCE .....	74
3.1	Precautions .....	74
3.1.1	Lifting the machine on a hoist.....	76
3.2	Walk-around Checking.....	77
3.3	Periodic Maintenance Points.....	78
3.4	Maintenance Procedure .....	80
(1)	Every 10 service hours or daily .....	80
(2)	Every 50 service hours .....	82
(3)	Every 250 service hours .....	83
(4)	Every 500 service hours .....	85
(5)	Every 1000 service hours .....	87
(6)	As needed .....	93
3.5	Consumable Parts.....	96
3.6	Fluid and Lubricant Capacities .....	98
3.7	Electric Wiring Diagram.....	100
3.8	Fuse Box and Line Fuse .....	102
3.9	Battery .....	102
4	SPECIFICATIONS.....	103

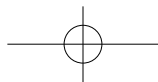
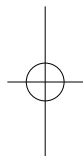
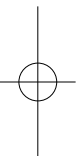
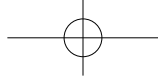

## MACHINE AND ENGINE IDENTIFICATION NUMBERS

When ordering parts or making inquiries about your machine, the following information is requested.

### (1) Machine model

Indicated on the dashboard in the operator's station.

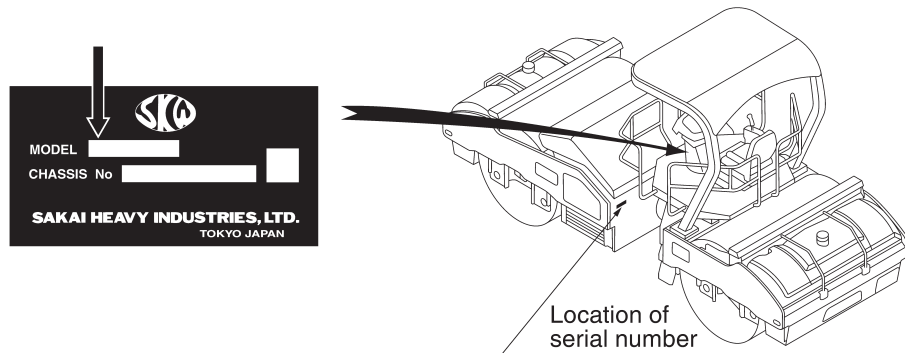

### (2) Machine serial number

SW880-1 → 4SW65 – ○○○○○○  
SW990-1 → 4SW67 – ○○○○○○

### (3) Engine serial number

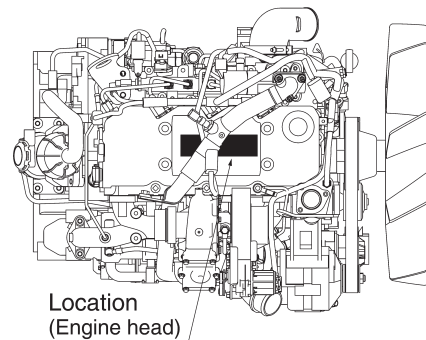







## **SAFETY NOTICES**

For the safe use of your machine, correct handling and periodic maintenance are of utmost importance. Thoroughly read the safety precautions described in this manual. Do not attempt to operate and maintain your machine until you gain a full understanding of these safety statements.

This manual covers the proper and safe method of driving and handling of this machine for its intended use. When this machine is used a manner, other than that covered in this manual, you must assume responsibility for your own personal safety.

In this manual and on the machine, you will find safety notices. Each safety notice starts with a signal word as shown below:

- |  |  |
|--|--|
|  <b>DANGER</b>    | <b>Denotes that there is an extreme hazard. If you fail to take proper precautions, it is highly likely that you could be killed or seriously injured. (The color of the symbol  is red)</b> |
|  <b>WARNING</b> | <b>Denotes that there is a hazard. If you fail to take proper precautions, you could be killed or seriously injured. (Symbol  is orange)</b>  |
|  <b>CAUTION</b> | <b>Calls attention to safety practices. If you fail to take proper precautions, you could be injured or cause damage to the machine. (Symbol  is yellow)</b>                                |

It is almost impossible for the safety notices in this manual and on the machine to cover all the potential dangers. Keep alert to possible dangers not mentioned in this manual and on the decals.

 **WARNING**

**Do not operate your machine before you read its operator's manual thoroughly.**

**Incorrect operation can kill or cause injury.**

**It is your responsibility to operate the machine safely.**

☆ Making alterations to the machine.

Please do not make alterations to the machine without permission for safety reasons.

We shall not be held responsible for injuries, death or breakdowns caused by alterations.

☆ Basic precautions for safe operation of your machine are discussed beginning on page 4.

☆ To operate and work with your machine, you must be qualified.

## 1. BASIC PRECAUTIONS FOR SAFETY

### 1 BASIC PRECAUTIONS FOR SAFETY

#### 1.1 General Precautions

##### ■ **Ensure proper management of health**

- People under the influence of alcohol, drugs, lack of sleep or health problems must avoid driving or repairing the machine at all times, as it may lead to serious accidents.

##### ■ **Turn off cell phones**

- Turn off cell phones while driving or repairing the machine. Never drive while talking on a cell phone, as it may lead to serious accidents.

##### ■ **Read the operator's manual thoroughly**

- Understand the functions of the controls and gauges. Familiarize yourself with their location and how to operate them. Understand the meaning of all the symbols.



##### ■ **When an instruction manual is lost or is damaged and is not legible, replace it immediately**

##### ■ **Understand the intended use of the roller**

- This roller is developed and manufactured mainly for rolling compactions of road constructions and repairing. Working with vibrations under excessive rolling compactions or using for crushing operations may cause damages to this machine. Do not use for any other purposes than rolling compactions in civil engineering works.

##### ■ **Obey the worksite rules**

- Follow noise standards and worksite rules such as matters forbidden or to be attended to, and working procedures.



▲ **WARNING:** Negligence of these instructions can lead to accidents.

## 1. BASIC PRECAUTIONS FOR SAFETY

### ■ **Wear protective clothing appropriate to work**

- Wear clothing, safety shoes and hard hat to suit your work.
- Do not wear clothing and accessories that tend to get caught in the controls or protruded portions of the machine. Do not wear oily clothing.
- Depending on the type of job, wear gloves, earplugs safety goggles or a mask.



### ■ **Know the work area in advance**

- Know the terrain, geology and conditions of the road surface at the worksite. Start working after securing safety such as stationing a guardsman or putting up barriers where there is a risk of falling of the machine or collapse of shoulder.

### ■ **The operator must make prior checks when moving the machine to a hazardous area under unusual conditions**

### ■ **Provide against an accident**

- Decide in advance the means of communication in an emergency. Know the location and use of a fire extinguisher and first-aid kit.

### ■ **Realize the capability of the machine**

- Thoroughly understand the performance of your machine and correctly operate the machine to meet the requirements of the job site. Operating the machine beyond its capabilities may lead to an accident. Use your machine within its capability.

### ■ **The machines not equipped with ROPS must not be operated on the slope or unsafe ground**

### ■ **The machines not equipped with CABIN must not be operated in the bad weather or a harmful contaminated zone**

**⚠ WARNING: Negligence of these instructions can lead to accidents.**

## **1. BASIC PRECAUTIONS FOR SAFETY**

### **■ Do not use a machine which has not been serviced correctly at regular intervals**

- Before working, perform necessary inspections. Start operation only after making certain the machine is in good operating condition. If found to be abnormal, report to the responsible person and have the fault corrected. Operate the machine after making sure that it is safe to operate.

### **■ Do not allow anyone to enter the work area except for authorized personnel**

- Always conduct the work paying attention to the workers around the machine.



### **■ Beware when operating moving parts**

- When operating moving parts such as covers, be sure to understand the way they move and take care not to get the hands and feet caught

### **■ Operator must sit in the seat when operating the machine**

### **■ Be careful of hot parts**

- After your machine has operated for some time, the coolant, engine oil and hydraulic fluid will become hot and the pressure will build up. If, in this state, you try to remove the filler caps, drain the oil or replace the filters, you can get burned. Perform this work in accordance with the correct procedures with the machine cooled down.
- To remove the radiator cap, slowly loosen the cap to relieve the pressure with the engine stopped and the coolant cooled down. (For the radiator cap with a lever, lift the lever to release the trapped pressure)
- When removing the filler cap on the hydraulic tank, release the trapped pressure by turning it out slowly to prevent the oil from gushing out.
- Do not touch the muffler while the engine is running or immediately after it has been shut down. You can get burned.
- While the engine is running or immediately after it has been stopped, do not touch the engine, muffler, exhaust pipes, oil hydraulic pumps, oil hydraulic motors, lights, etc., as they will be hot.
- Resin and metallic parts may become hot under direct sunlight on a hot day. Direct contact with such parts may cause burns, so be sure to wear clothing and protective equipment appropriate for the job.



**⚠ WARNING:** Negligence of these instructions can lead to accidents.

## 1. BASIC PRECAUTIONS FOR SAFETY

### ■ Be careful with fire

- The fuel, oil, and anti-freeze will catch fire if open flames or ignition sources are used close to them. Particularly, the fuel is highly flammable.



- Do not smoke or use a match or cigarette lighter close to inflammables. (combustibles)
- When refueling, stop the engine and do not smoke.
- The filler caps of the fuel and oil tanks must be kept tight.



### ■ Ensuring safety in a fire

- Machine fires may cause serious injuries or death, so stop the engine by turning the starter switch to the “OFF” position, then move away from the machine as quickly as possible.

### ■ While the engine is running or immediately after it has been turned off, do not touch the muffler, exhaust pipe or DPF

- While the engine is running or immediately after it has been turned off, do not touch the muffler, exhaust pipe or DPF, as they will be hot.

### ■ Mount on or dismount from your machine after it has come to a complete stop

- For getting on and off, face the machine and use the handrail and step.
- Watch your step when getting on or off the machine.
- Do not jump on or off a machine, particularly when it is moving.

### ■ Be careful not to fall

- Falling off the machine may cause serious injuries or death, so do not place your feet anywhere other than on the steps, and in the driver's seat.

### ■ Do not lock out yourself when leaving the machines

- Always bring the key with you by pulling it out from the starting switch when leaving the machine.

**⚠ WARNING: Negligence of these instructions can lead to accidents.**

## **1. BASIC PRECAUTIONS FOR SAFETY**

### **■ To handle the hydraulic fluid**

- Wear safety goggles to protect your eyes from contact with hydraulic fluid. It can irritate your eyes.  
If the fluid contacts your eyes, flush with clean water for 15 minutes and get medical aid.
- The fluid can also irritate your skin. When handling it, wear rubber gloves to avoid contact with it. In case of skin contact, wash with soap and water.
- Be careful not to swallow the fluid. It can cause diarrhea and emesis.  
If swallowed, do not try to vomit. Get medical help immediately.



### **■ Do not use worn tires (tire installed)**

- Tires may be damaged when they are scratched on curb stones, when the machine runs over irregular surfaces of roads or projections on roads, and when the machine is operated suddenly.
- Continued use of damaged tires will cause them to blow out. Replace them with new ones.

## **1.2 Preparation for Safe Operation**

### **■ Clean the step, operator's station and floor board and brake pedal**

- Do not place parts, tools or unnecessary articles on the step, operator's station and floor board.
- Keep the step, floor board, brake pedal, controls and handholds free from muds, oil, ice or water, as they can cause slippage. Repair them if found to be damaged. Tighten loose bolts.
- Keep your boot soles free of oil or muds. They can slip, leading to an accident.

### **■ Inspect your machine before operation**

- Check your machine for damage such as cracks and deformation. If found to be abnormal, operate the machine after taking a proper measure to secure safety.
- Check the level of fluids. (fuel, engine oil, coolant, anti-freeze and hydraulic oil) Add as necessary.
- Check the area where the machine has parked for signs of leakage of oil, fuel and water. If any leakage is noticeable, determine the cause and make corrections immediately.

**▲ WARNING:** Negligence of these instructions can lead to accidents.

## 1. BASIC PRECAUTIONS FOR SAFETY

### ■ Watch your distance

- When traveling on a road, bear in mind the stopping distance. Avoid excessive speed, and abrupt starting and stopping, and moving in a zigzag direction.

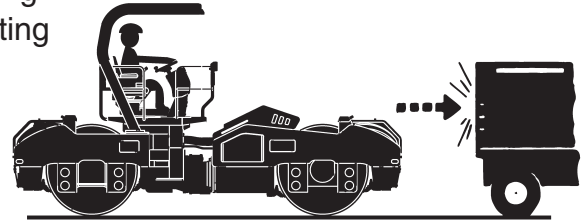

### ■ Understand ROPS functions (with ROPS)

- Ensure that there is no loose bolt, crack nor rust on the bodies and the attaching portions of ROPS.
- Tighten bolts with the specified torques after ROPS are removed.  
Tightening torque : **883 N · m**
- Do not weld nor drill holes to the ROPS parts without the permissions from SAKAI, because it may decrease strengths of the ROPS.

## 1.3 Before Starting the Engine

### ■ It is confirmed that hood and door is closed

- Please confirm hood and door has put it away in the confirmation before it gets on.

### ■ Adjust the operator's seat to your most effective operating position

- Sit on the operator's seat. Adjust the seat so that your back will make contact with the seat back when the brake pedal is pressed down to the full extent. Check to be sure that the brake pedal can be fully pressed down without difficulty when you twist your body for reverse run.
- Adjust the seat to allow proper operation of the steering wheel, levers, switches, etc.

### ■ Secure good visibility (with CABIN)

- Keep the windowpanel clean.
- Lock the windows and doors no matter whether they are open or closed.
- Do not leave the doors half-closed.

### ■ Secure forward and backward visibilities

- Adjust the rear view mirrors and under mirrors for good visibility. If dirty, clean them. If damaged, replace.

 **WARNING:** Negligence of these instructions can lead to accidents.

## 1. BASIC PRECAUTIONS FOR SAFETY

### ■ Check that the horn, lamps and gauges work correctly

### ■ Before starting, make certain that each lever is in the neutral position and the parking brake is applied

### ■ When starting, sound the horn

- Before starting the engine. Make sure there is no one in the immediate vicinity and there are no obstructions around the machine.



### ■ Sit in the driver's seat and turn on the engine

- Do not start the engine anywhere other than from the driver's seat as there is the danger of operational mistakes.

### ■ Pay attention to ventilation

- Exhaust fumes are dangerous if breathed in. When starting the engine in an enclosed area, provide good ventilation with windows and doors opened.



### ■ Do not stand close to the exhaust gas pipe opening

- The exhaust gas from the engine is dangerous.
- Exhaust fumes are harmful if breathed in.

## 1.4 After Starting the Engine

### ■ Secure safety around the machine

- Ensure that the area around the machine is clear of personnel and obstructions. Moreover, honk the horn, indicate your intention to move, and wait a while before moving off.



**▲ WARNING:** Negligence of these instructions can lead to accidents.

## 1. BASIC PRECAUTIONS FOR SAFETY

### ■ Warm up the engine

- Do not put your machine into motion immediately after the engine has started, let it idle for several minutes until it is at operating temperature.
- Check the area where the machine has parked for signs of leakage or oil, fuel and water. If any leakage is noticeable, determine the cause and make corrections immediately.

### ■ Have a trial run

- Make a test run in a safe place to check that there are no abnormal signs. If found to be abnormal, correct the fault before traveling again.
- Listen for unusual sounds, and check for abnormal temperature rise. If abnormal, park the machine in a safe place and find the source of trouble before operating.

## 1.5 During Operation

### ■ Strictly observe the traffic regulations

- Follow all the traffic regulations when driving on a public road.

### ■ Sit in the driver's seat before starting operation

- Sit in the driver's seat before starting operation. Be sure to wear the seat belt when provided.

### ■ Seat belt (with seat belt)

- Be sure to wear the seat belt during operation.

### ■ No other person but the operator

- This machine is a one-man roller. Do not allow anyone to get on. Only the operator is allowed on this machine while it is running or in operation. Radios are not permitted.

### ■ Sit in the driver's seat before starting operation

- Be sure to wear the seat belt when provided.

### ■ Before mounting, be sure areas around the machine are safe

- Before getting on the machine, make certain that there are no obstacles around the machine and no workers under it. If some workers are present or close to the machine, tell them that the machine is about to move, warning them to stay away from it.

**⚠ WARNING: Negligence of these instructions can lead to accidents.**

## **1. BASIC PRECAUTIONS FOR SAFETY**

### **■ Do not try to get on or off a moving machine**

- Get on or off the machine after making sure it has come to a complete stop and the parking brake is applied.

### **■ Do not let anyone enter the work area**

- There is the danger of being run over causing serious injuries or death.
- If the driver does not have a clear field of vision, assign a conductor to help.

### **■ To go uphill or downhill, run at a low speed. Do not attempt to shift speeds while traveling on a slope**

- Shifting speeds on a slope can cause unexpected running down the slope.
- Going down hill at speeds other than low range can cause the machine to run down violently.

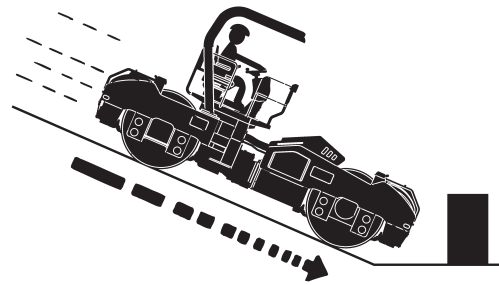

### **■ Refrain from inattentive driving**

- Inattentive driving or driving relying on guess work can cause an accident. Use extreme care for workers present in the path of the roller or around it. In case of danger, stop and sound the horn, and proceed when the area is clear of personnel or obstructions.

### **■ When changing the direction of travel, secure the safety on the path in the travel direction**

### **■ Keep everyone away from the pinch points**

- When making turns, do not allow anyone to come close to the pinch point.





▲ **WARNING:** Negligence of these instructions can lead to accidents.

## 1. BASIC PRECAUTIONS FOR SAFETY

### ■ **At night, carefully drive the machine**

- Nighttime driving tends to frustrate the sense of distance. Carefully drive the machine at a speed suited to illumination. Keep the headlamps and flood lamps lighted. If necessary, provide extra lighting in the work area.

### ■ **Avoid long hours of continual operation**

- Avoid long hours of continual operation as it may lead to loss of health.

### ■ **Repair as soon as possible if found to be defective**

- If the machine is found to be faulty, stop the machine and repair it. Do not operate the machine until the problem is corrected. When any warning lamp indicates faulty operation, inspect the machine after moving it to the nearest safe location.

### ■ **Do not operate the machine except from the operator's seat. Do not drive in a standing posture**

- Do not throw your legs out or lean forward. Be sure to sit in the proper position while driving the machine.

### ■ **While making turns, do not run at a high speed and do not turn the steering wheel abruptly and sharply. High speed turns, especially on soft or uneven ground, could result in a rollover**

### ■ **For the traveling on structures such as a bridge, make certain that they can support your machine. Before traveling on the structure, you must know the load capacity of the structure and the load weight of the machine you are operating to insure safe travel across the structure**

### ■ **Do not make turns on a slope and do not travel across sidehill. If necessary to do so, go down straight along the slope to the flat ground, move sideways and go up straight to the destination**

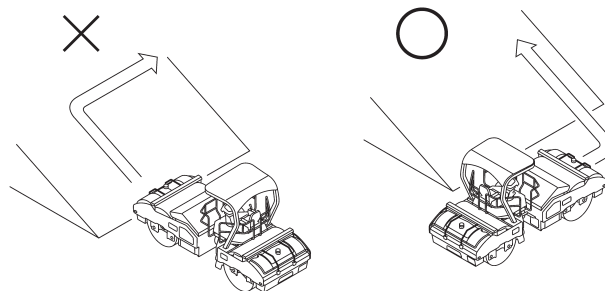

**⚠ WARNING: Negligence of these instructions can lead to accidents.**

## 1. BASIC PRECAUTIONS FOR SAFETY

### ■ On a step slope, run the machine at low speed

### ■ When parking

- Select level and hard ground. If necessary to park on a slope, block the front of the drums and tire on the downside of the slope.
- When required to park on a public road, provide necessary markings such as flags, barriers and illumination. However, be sure they do not obstruct traffic.
- Stop the engine when getting off the machine. Remove the key from the starter switch, and make sure it is stored appropriately.
- Be sure not to get your hands caught in the blocks when handling them.

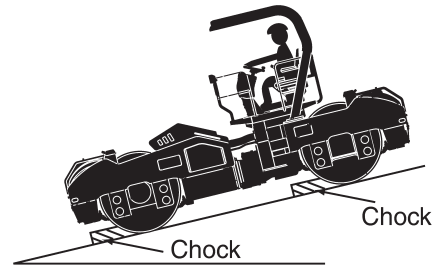

## 1.6 Loading and Unloading

- Loading and unloading can accompany any danger. Use extreme care.
- Select level and hard ground leaving a sufficient distance from the shoulder of a road or bank.
- Use sturdy ramps with proper width, length and thickness which allow safe loading and unloading. If they deflect considerably under load, apply wooden blocks to reinforce the ramps.
- To prevent your machine from crosswise slippage, keep the ramps free from oil, mud, debris, etc. The drum must also be free from extraneous matter that can cause slippage.
- Do not steer your machine on the ramps. If the machine is facing in the wrong direction, go back off the ramp the ramps, correct the direction and try again.
- Do not use kinked, twisted or damaged wire ropes for crane or winch operation. Use ones with ample strength.
- When loading is complete, fix the machine with wooden blocks placed under the drums and chains fastened to the machine.

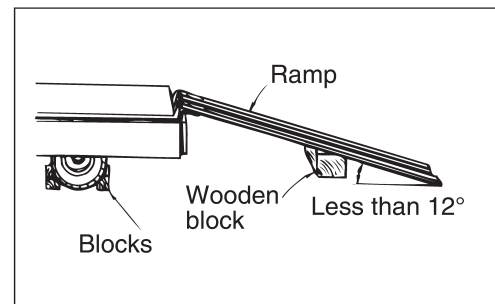

## 1.7 Transportation

- Follow required regulations.
- Select a transporting route according to the overall width, overall height and gross weight of the trailer with the roller loaded.
- Know the maximum height clearance of the machine loaded on the transport trailer before hauling under bridges and other structures.

**⚠ WARNING: Negligence of these instructions can lead to accidents.**

## 1. BASIC PRECAUTIONS FOR SAFETY

### 1.8 Handling the Battery

#### ■ When handling the battery

- Battery electrolyte contains sulphuric acid. It will destroy clothing and skin. If it touches your clothing or skin, flush with large quantities of water.
- In case of eye contact, flush with clean water and get medical help.
- If swallowed, drink large amount of water, milk, beaten egg or vegetable oil, and get medical help.
- Wear safety goggles when handling the battery. Wear safety goggles, full face shield, rubber gloves and rubber apron when adding fluids to the battery.
- Keep cigarettes and flames away, and avoid recharging the battery in poorly ventilated places when there is a danger of generating sparks.



#### ⚠ WARNING

**Battery posts, terminals, and related accessories contain lead and lead compounds, chemicals known to the State of California to cause cancer and reproductive harm. Wash hand after handling.**

- Inspect or handle the battery with the engine stopped and the starter switch in the "O" position.
- Keep metallic items such as tools away from the battery terminals.
- Tangled terminals may generate sparks due to improper connections, resulting in the danger of explosions. Make sure terminals are connected firmly.
- The battery is for starting the engine and operating electrical equipment on the machine. Do not use it for any other purpose.
- Do not charge battery when the top surfaces of the liquids are at the LOWER level (the minimum liquid level) or below. Not only the internal parts of the battery are degraded and the battery lifetime are shortened but also it can cause explosions if you continue on using the battery when the top surfaces of the liquids are at the LOWER level or below. Immediately supply water until the water level is between the UPPER and LOWER levels.

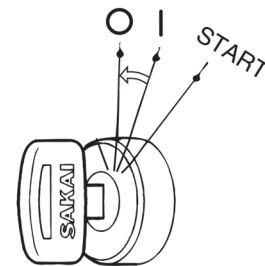

⚠ **WARNING:** Negligence of these instructions can lead to accidents.

## 1. BASIC PRECAUTIONS FOR SAFETY

### ■ Jump-starting the engine

- Wear safety goggles when jump-starting the machine.
- When starting from another machine, do not allow the two machines to make contact with each other.
- When connecting the battery cables, start with the positive terminal. For disconnection, start with the negative one.
- Do not allow a tool to bridge between the positive terminal and machine body. This can generate dangerous sparks.
- Do not connect the booster cable to wrong the terminal. Never connect the positive terminal to the negative terminal or the body of the machine.
- Final connection to the engine block of the disabled machine can cause sparks. The connecting point should be as far as possible from the battery.

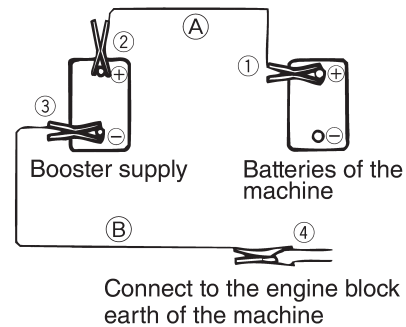
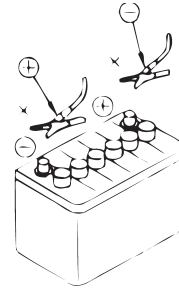

## 1.9 Towing

- Towing should only be carried out in emergencies and over short distances. A trailer should be used for long distance transport.
- The machine should not be operated while being towed.
- Follow the instructions in this manual to enable towing.
- Do not tow if the braking system has broken down, as it is dangerous.
- To tow the machine, use cables with ample strength.
- Do not perform towing on a slope.
- Be sure to attach a wire rope firmly to the towing hook.
- Do not use twisted, kinked or damaged cables when towing.
- Do not step over the wire rope.
- Keep everyone away from the space between the machine and the towing machine when connecting the two.
- Align the connection points of the disabled machine and the towing machine in a straight line when connecting the machines.

**⚠ WARNING: Negligence of these instructions can lead to accidents.**

## 1. BASIC PRECAUTIONS FOR SAFETY

### 1.10 Before Servicing

#### ■ Attach warning tags when servicing the machine

- Serious accidents can occur if the machine is unexpectedly started or controls carelessly touched by an unauthorized person.
- Attach a warning tag at a clearly visible location in the operator's station and insure the key has been removed from the starter switch.



#### ■ Setting the blocks

- Set blocks in front of and behind the roller drum (wheels) to prevent the machine from moving before beginning inspections or maintenance work.

#### ■ Use proper tools

- It is very dangerous to use damaged or deteriorated tools or to use tools for purposes other than intended. Use correct tools for their intended use only.



#### ■ Change safety-related parts at regular intervals

- Change any seatbelt found to be abnormal even if it is within its recommended service interval.
- Change any ROPS found to be abnormal even if it is within its recommended service interval.
- Replace fuel hose, high pressure hydraulic hoses and liquid hoses regularly to prevent fire. Replace high pressure hoses of the power steering system every two years.
  - ☆ Change these parts at regular intervals even if found to be normal. They will deteriorate as time goes on.
  - ☆ Change any hose found to be abnormal even if it is within its recommended service interval.

**⚠ WARNING: Negligence of these instructions can lead to accidents.**

## 1. BASIC PRECAUTIONS FOR SAFETY

### ■ Inspect or service your machine with the engine stopped

- If required to keep the engine running in such a case as radiator interior cleaning, perform the work with two persons. One of them should sit on the operator's seat getting ready for shutting down the engine. He must take care not to touch any of controls carelessly. Maintenance personnel must exercise extreme caution not to make contact with moving parts.

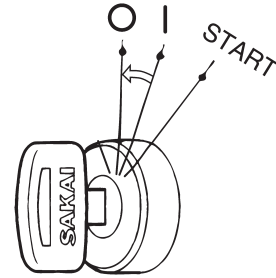

### ■ Supplying fuel, oils and grease

- Do not cover the filler port when refueling. Feeding fuel in an airtight tank might damage the fuel tank.
- Spilled fuel or oil will be slippery. Wipe up immediately. Keep the filler caps tight. Do not use fuel for flushing oil. Handle fuel and oil in a well ventilated area.

### ■ Check the coolant level in the radiator

- To check the coolant level, stop the engine and allow the engine and radiator to cool down before removing the radiator cap. Remove the cap by covering it with a rag before removing to prevent any fluid that could spray under pressure from causing a burn.

### ■ Illumination

- For inspecting the level of the fuel, oil, coolant and battery electrolyte, use explosion-proof illuminations. Failure to use this type of illumination can result in an explosion.



### ■ Make sure the gas dampers are properly maintained

- Before inspecting the engine room, make sure the gas dampers holding up the hood are firmly engaged. Furthermore, in machines with stays to prevent the hood from closing, make sure they are firmly in place.

**▲ WARNING:** Negligence of these instructions can lead to accidents.

## 1. BASIC PRECAUTIONS FOR SAFETY

### 1.11 During Servicing

#### ■ Keep unauthorized persons away

- During service, do not allow persons not concerned to enter the work area, particularly when grinding or welding operation is performed or heavy hammers are being used.



#### ■ Assume an appropriate posture while working

- An unnatural posture during maintenance work may cause injuries. Assume a posture that is appropriate for the work being carried out.

#### ■ Keep your machine clean

- Spilled oil, grease or scattered debris are dangerous. Always keep your machine clean. Moisture that penetrates into the electrical system can cause malfunctions. Do not use water to clean sensors, connectors and the operator's station.

#### ■ Take care not to get caught or crushed

- Be sure to fix the hood and other covers after opening them to prevent closing and avoid getting caught in them.
- If there is a need to crawl under the machine after it has been lifted, be sure to support it from underneath with a solid prop or block.

#### ■ When repairing the electrical system

- Read the warnings in this manual regarding the handling of batteries, and make sure to have a thorough understanding in order to handle them appropriately and safely.
- When repairing the electrical system or welding, disconnect the negative cable from the battery to shut off the electricity. Carrying out work while the cables are connected to the negative terminal may cause electrocution or explosions.



#### ■ Carefully handle high pressure hoses

- Do not try to bend or hit hoses against a hard object. Do not use hoses or pipes that are bent or damaged. They will burst.
- Replace damaged fuel hose, hydraulic hoses and liquid hoses. An oil, hydraulic and liquid fluid spill can cause a fire.

## 1. BASIC PRECAUTIONS FOR SAFETY

### ■ Be careful of high pressure hydraulic fluid

- Bear in mind that the working equipment hydraulic systems are under internal pressure. Do not perform adding, draining, inspection or servicing of the hydraulic systems until the internal pressure has been relieved. Hydraulic fluid leaking through a fine hole at high pressure can penetrate your skin and eyes. Inspect leakage by holding a hard board close to suspected leaks and wearing goggles. If affected by high pressure oil, get medical help immediately.



### ■ Be careful of hot parts

- After the machine has been operated for some time, the coolant, engine oil and hydraulic fluid will become hot.
- Removing the radiator cap or draining the coolant or oil can burn you. Perform this work in accordance with correct procedures after the systems have cooled down.



### ■ Use care when inspecting or servicing fan or belts in motion

- Do not wear clothing and accessories that tend to get caught in moving parts.
- Do not let your body or tools make contact with the fan blades or belts. They can be cut seriously.



### ■ Used oil disposal

- Do not throw used oil into a drain or waterway. Drain the oil from the machine into a proper container. Do not drain directly on the ground.
- Obey all local, state and federal environment regulations for the proper disposal of oil, fuel, coolant, battery electrolyte or any other fluids.

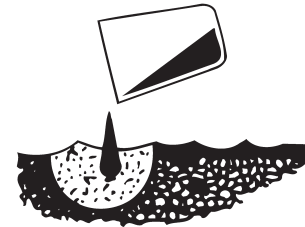



**⚠ WARNING: Negligence of these instructions can lead to accidents.**

## **1. BASIC PRECAUTIONS FOR SAFETY**

### **■ Take care in handling the gas damper**

- Never dismantle it.
- Do not throw it into a fire.
- Do not damage the rod.
- Do not bend the tube or rod, or use it as a handle.
- When disposing of it, be sure to fix the gas damper, and drill a hole around 2 to 3 mm in diameter, about 20 to 30 mm from the edge on the tube bracket side. Dispose of it after releasing the gas pressure. When doing this, be sure to wear protective goggles because of the danger of oil inside or swarfs getting sprayed everywhere by the compressed gas inside.

### **■ Exercise extreme care when replacing and repairing tires (Tire installed)**

- Disassembly, repair and reassembly of tires require special facility and knowledge. Have them repaired at work shop specialized in handling tires.
- An improperly fitted tire can separate from the rim when inflating.
- When dismounting a tire, chock other tires for safety.
- When welding job is carried out near the tires, use extreme care, as this can cause an explosion of the tires.

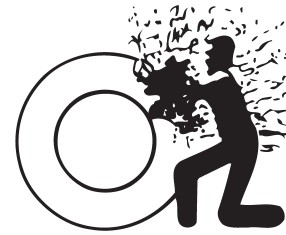



**⚠ WARNING: Negligence of these instructions can lead to accidents.**

**1. BASIC PRECAUTIONS FOR SAFETY**



**1.12 Safety Decals**

Keep all decals clean. If lost, replace with new one. There are decals other than those shown below: Treat them in the same manner as the one shown here.



① 3998-16696-0

<b>⚠ DANGER</b>	
	<ul style="list-style-type: none"> <li>Do not approach, or allow objects to touch the rotating parts.</li> <li>Body parts which make contact with rotating mechanism will be severed.</li> </ul>
	<ul style="list-style-type: none"> <li>Do not open the radiator cap and the auxiliary tank cap when fluid is hot.</li> <li>Radiator fluid is flammable. Avoid exposure to flame when the cap has been removed.</li> </ul>
	<ul style="list-style-type: none"> <li>Avoid contact with machine parts in the vicinity of the engine while engine is running and after it has been stopped. Contact with hot part will cause burns.</li> </ul>

⑦ 3998-16646-1

	
---	---

⑧ 3998-16652-0

		<b>⚠ WARNING</b>
<ul style="list-style-type: none"> <li>Avoid inhalation of exhaust gas.</li> <li>Avoid contact with exhaust pipe while engine is running and after it has been stopped. Contact with hot exhaust pipe will cause burns.</li> </ul>		

⑫ 1568-19011-1

<b>⚠ WARNING</b>	
<p>1. This vehicle may malfunction from a strong electromagnetic wave in its neighboring environment. Control is maintained using electronics. Do not use this vehicle in an environment that may expose it to a strong electromagnetic wave. Do not use a device with a strong electromagnetic wave on or near this vehicle.</p> <p>2. Electronics on this vehicle emit a minor electromagnetic wave. Do not operate this vehicle if you wear a pacemaker. Long term operation may cause damage to your health from the electromagnetic wave.</p>	

② 3998-16505-0

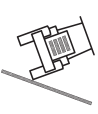
<b>⚠ DANGER</b>	
	<p><b>Roll Over Prevention</b></p> <ul style="list-style-type: none"> <li>Do not work in the vicinity of overhanging banks, or on grades steep enough to cause the machine to slide or roll over.</li> <li>Reduce speed prior to making turns.</li> <li>Pay particular attention when operating on uneven surfaces, as the machine may become unstable.</li> </ul>



⑨ 3998-16504-0

<b>⚠ WARNING</b>	
<p>1. When Handling the Machine:</p> <ul style="list-style-type: none"> <li>Operate only while seated.</li> <li>Use the handrails and steps when boarding and getting off.</li> <li>Never carry passengers.</li> <li>Never attempt to board or get off the machine while it is moving.</li> </ul> <p>2. Preparation for Safe Operation</p> <ul style="list-style-type: none"> <li>Clean the steps, operator's station and floorboards.</li> <li>Obey the worksite rules.</li> <li>Sakai accepts no responsibility for any injury or damage to the machine caused by unapproved modification.</li> <li>Do not use a machine which needs repair or maintenance.</li> <li>Sound the horn immediately prior to starting the engine to warn people in the vicinity.</li> </ul> <p>3. Starting the Engine</p> <ul style="list-style-type: none"> <li>Check that all operating levers are in the neutral position.</li> <li>Idle the engine for about 5 minutes to warm it up prior to commencing work.</li> </ul> <p>4. Parking Precautions</p> <ul style="list-style-type: none"> <li>When parking the machine, park it on level ground, set the parking switch and set the roller chocks.</li> <li>Allow the engine to cool off by running it for about 5 minutes before stopping.</li> <li>When getting off the machine, remove the key from the ignition switch.</li> </ul>	

⑬ 3998-16489-0

<p><b>CALIFORNIA</b> Proposition 65 Warning</p> <p>Diesel engine and some of its constituents are known to the State of California to cause cancer, birth defects, and other reproductive harm.</p>	
---	--

③ 3998-16501-0

<b>⚠ DANGER</b>	
 	
<p><b>Be Careful with Fire</b></p> <ul style="list-style-type: none"> <li>When refueling, stop the engine and do not smoke.</li> <li>The filter cap of the fuel tank must be kept tight.</li> </ul>	

⑭ 3998-16510-0

<b>⚠ CAUTION</b>	
<p>Refill the specified quantity of oil in the vibrator case when changing oil.</p>	

④ 3998-16559-0

<b>DANGER EXPLOSIVE GASES</b>	
Cigarettes, flames or sparks could cause battery to explode. Always shield eyes and face from battery. Do not charge or use booster cables or adjust post connections without proper instruction and training.	
<b>KEEP VENT CAPS TIGHT AND LEVEL</b>	
<b>POISON CAUSES SEVERE BURNS</b>	
Contains sulfuric acid. Avoid contact with skin, eyes or clothing. In event of accident, flush with water and call a physician immediately.	
<b>KEEP OUT OF REACH OF CHILDREN</b>	

⑮ 3998-16507-1

<b>⚠ CAUTION</b>	
<p>Lubricate all grease fittings daily prior to commencing work.</p>	

⑤ 3998-19678-0

(2 locations)



⑥ 3998-06139-0



⑩ 3998-16499-0

<b>⚠ WARNING</b>		
		
<ul style="list-style-type: none"> <li>Do not open the hood with the engine running.</li> <li>Contact with hot parts will cause burns.</li> <li>Contact with rotating parts will cause severe injury.</li> </ul>		

⑯ 2998-96001-1

<b>⚠ CAUTION</b>	
<b>USE SPECIFIED FUEL ONLY</b>	
<ul style="list-style-type: none"> <li>Use of other than the specified fuel may result in damage to the engine.</li> <li>Please refer to the manual for details.</li> </ul>	

⑰ 3998-16680-0

<b>⚠ CAUTION</b>	
	<p>Reference service manual for special fill procedure. Failure to follow this procedure can result in severe engine damage.</p>

⑪ 3998-16547-0 (4 locations)

	<b>⚠ WARNING</b>
<ul style="list-style-type: none"> <li>Take care to avoid pinching of hands or fingers when closing this cover.</li> </ul>	

⑱ 1568-19037-0

<b>⚠ CAUTION</b>	
<p>The engine should not be started while the WAIT TO START LAMP is lit.</p>	

**⚠ WARNING: Negligence of these instructions can lead to accidents.**

**1. BASIC PRECAUTIONS FOR SAFETY**

SW880-1, SW990-1

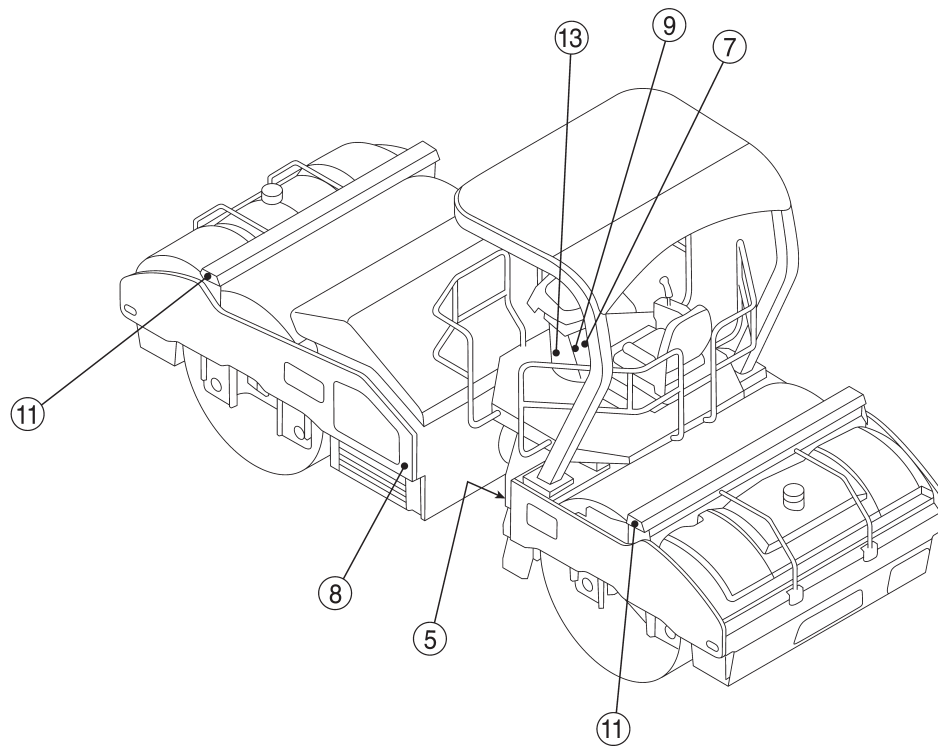
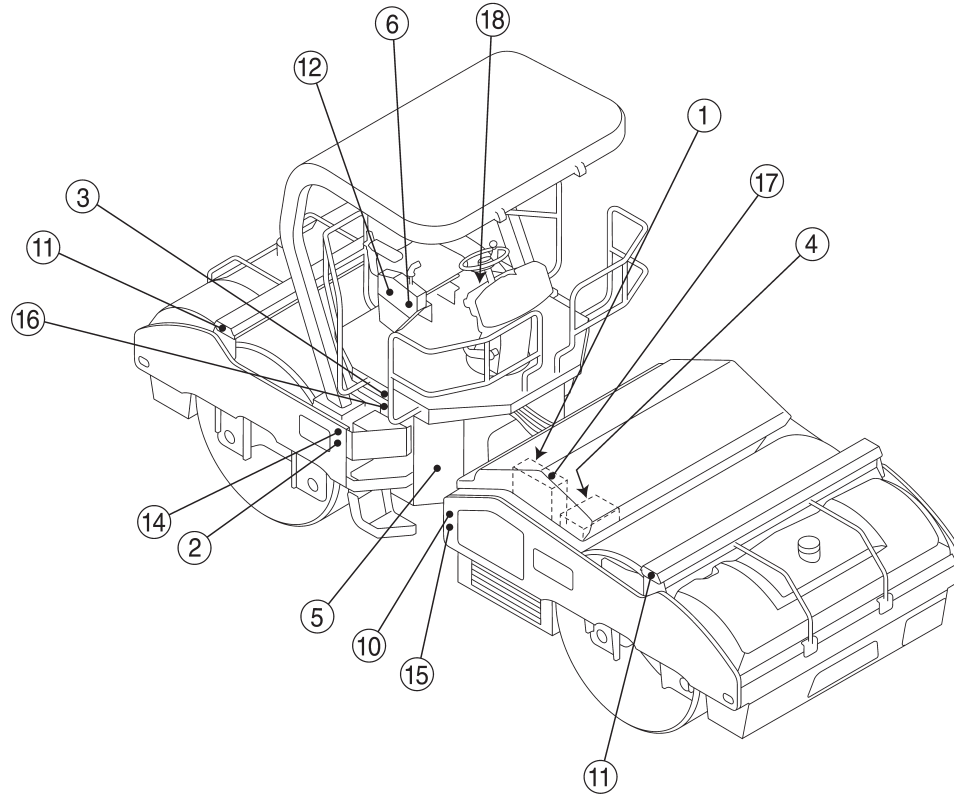

## 2. OPERATION

### 2 OPERATION

#### 2.1 Instruments and Controls

##### 2.1.1 Operator's station

**NOTE:**

\*marked switches are responded only when the F-N-R lever is in the neutral position.

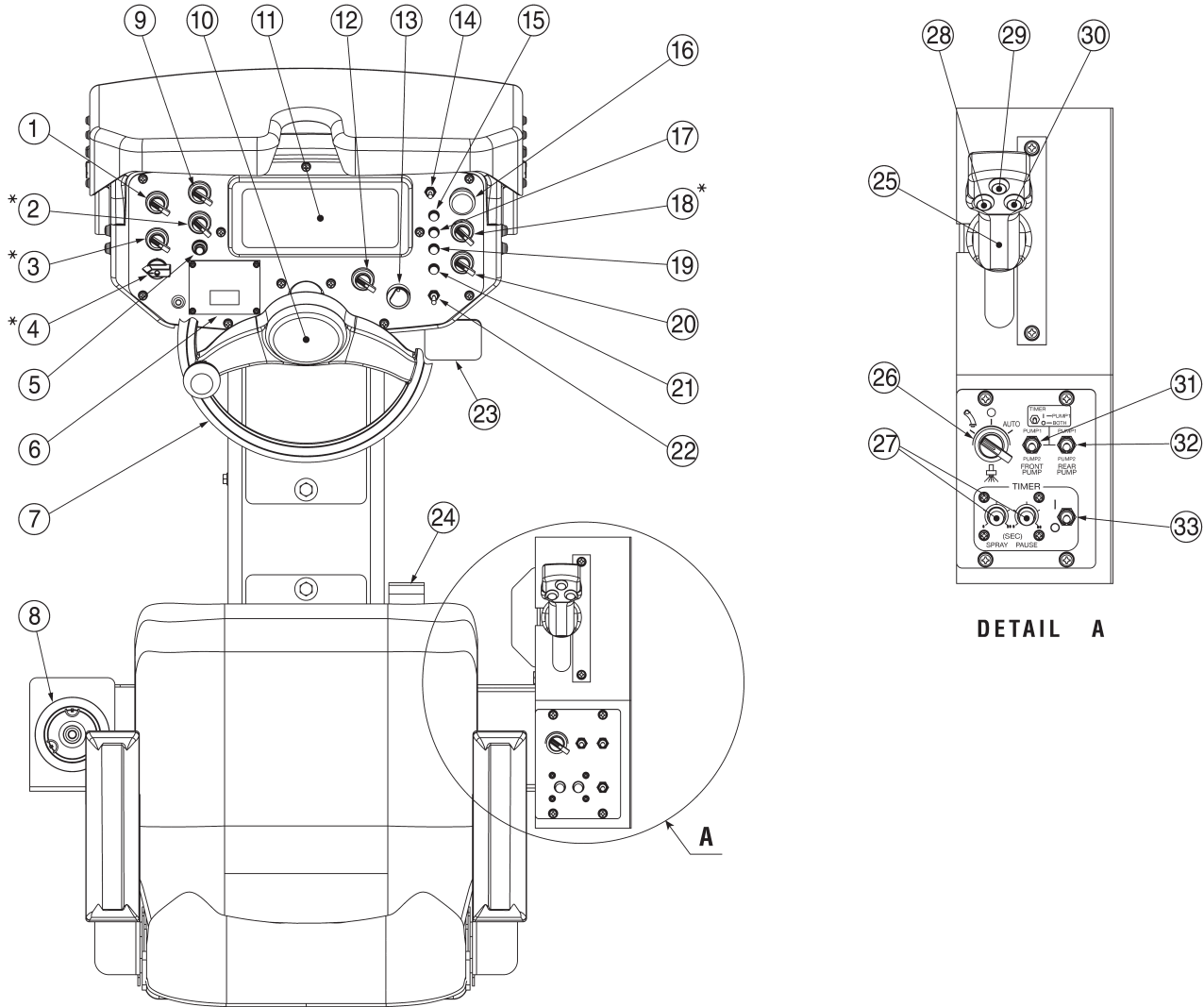

- |  |   |
|--|---|
| ① Vibration drum selector switch                             | ①⑦ Warning lamp   |
| ② Vibration amplitude selector switch                        | ①⑧ Propel speed selector switch                           |
| ③ Vibration frequency selector switch                        | ①⑨ Wait to start lamp                                     |
| ④ IPF selector switch  | ②⑦ Engine speed selector switch                           |
| ⑤ Auto speed lamp  | ②⑧ EGT. Warning lamp                                      |
| ⑥ Exact compact meter  | ②⑨ Engine diagnostic switch                               |
| ⑦ Steering wheel   | ②⑩ Brake pedal  |
| ⑧ Drink holder   | ②⑪ Swivel release pedal                                   |
| ⑨ Vibration mode selector switch<br>(Manual or Auto control) | ②⑫ Forward-Neutral-Reverse lever (F-N-R lever)            |
| ⑩ Horn switch button   | ②⑬ Spray mode selector switch<br>(Manual or Auto control) |
| ⑪ Combination meter  | ②⑭ Spray timer dial                                       |
| ⑫ Lamp switch  | ②⑮ Vibration switch                                       |
| ⑬ Starter Switch   | ②⑯ Auto speed set switch                                  |
| ⑭ Emergency propel switch                                    | ②⑰ Spray switch   |
| ⑮ Engine stop lamp   | ②⑱ Front spray pump selector switch                       |
| ⑯ Parking brake switch                                       | ②⑲ Rear spray pump selector switch                        |
|  | ②⑳ Spray timer switch                                     |

### 2.1.2 Gauges, indicator lamps and warning lamps

For safe execution of your job, fully understand the role and function of the systems involved.

#### Combination meter

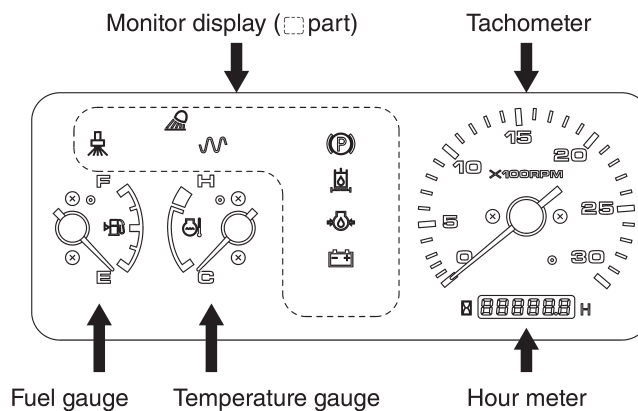

#### Tachometer / Hour meter

Indicates the engine RPM. The hour meter shows total operating hours. The service interval recommendation in this manual should be based upon the hour meter readings.

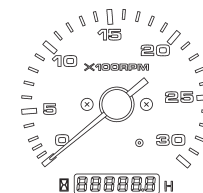

Tachometer / Hour meter

#### Temperature gauge

Indicates the coolant temperature. Zone close to symbol H indicates overheating. In case of overheating, run the engine at idling for about ten minutes before shutting it down. Then determine the cause.

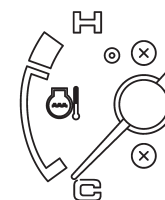

Temperature gauge

#### Fuel gauge

Indicates the fuel level in the tank.

E: The tank is empty.

F: The tank is full.

Replenish fuel appropriately before the fuel runs down.



Fuel gauge





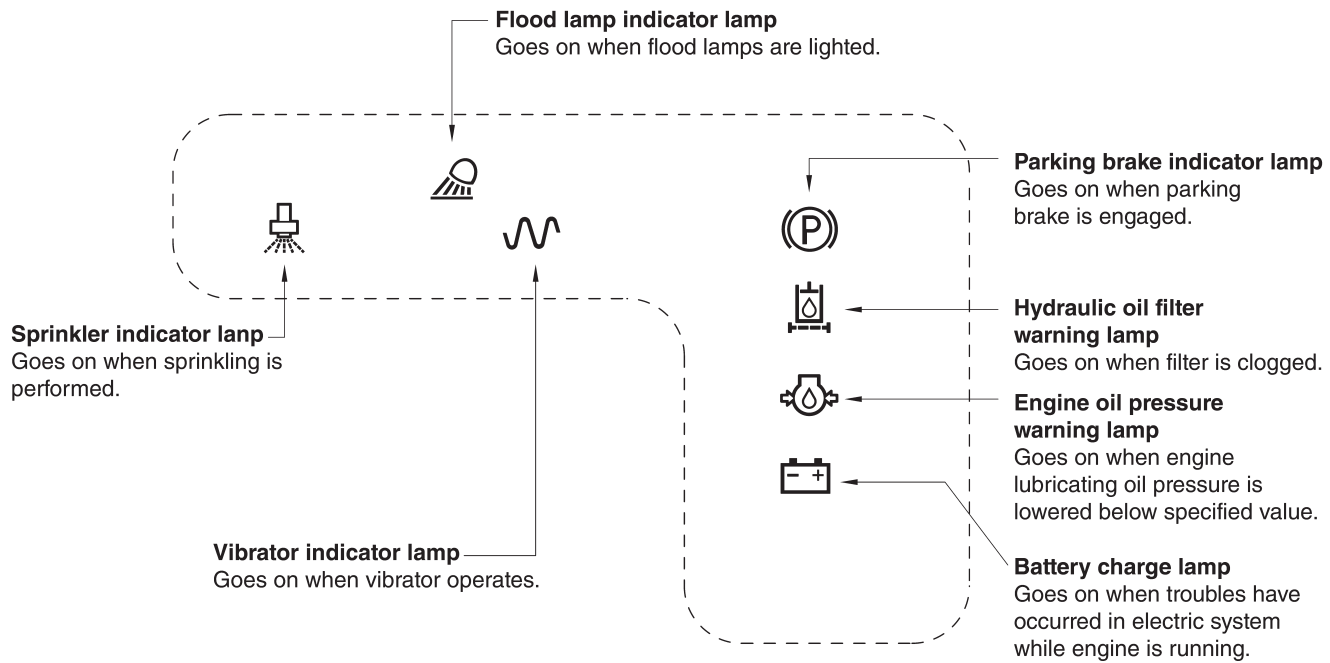

#### ⚠ CAUTION

Be sure to use fuel recommended by SAKAI. (refer to page 98)

## 2. OPERATION

### Monitor display



- ★ Indicator lamps [    ]  
Light up when corresponding systems have been operated.
- ★ Parking brake indicator lamp [  ]  
It will flash once when the starter switch is turned to the "ON" position.  
After that it will remain on while the parking brake is engaged, and turn off when it is released.
- ★ Hydraulic oil filter warning lamp [  ]  
It will flash once when the starter switch is turned to the "ON" position.  
After that it will turn on when the hydraulic oil filter becomes clogged. Stop the machine and carry out an inspection.
- ★ Engine oil pressure warning lamp [  ]  
It will flash once when the starter switch is turned to the "ON" position.  
It will turn on while the engine is running if the engine oil pressure drops below the specified value. Stop the machine and carry out an inspection.
- ★ Battery charge lamp [  ]  
It will turn on when the starter switch is turned to the "ON" position, and turn off when the engine starts running.  
It will turn on while the engine is running when a problem arises with the electric system. Stop the machine and carry out an inspection.

**IMPORTANT**

- **Hydraulic oil filter warning lamp**  
Go on when the engine rpm is increased before the engine has been warmed up enough. Keep the engine idling until the lamp goes off, before starting your work. In that case, warm up the engine sufficiently, and operate the machine after the warning light has gone out. When the warning light will not go out, the filter may be clogging up. Check the filter.
- **Checking for warning lamp and parking brake indicator lamp**  
They should turn on light when the starter switch in ON position. If not, there is some trouble.  
Check and repair the combination meter or wirings harness.
- **The window of the combination meter**  
The window of the combination meter may become invisible because of aged deterioration caused by fine sand or dust or ultraviolet. When any flaw or mist is found on the window, contact our branch offices or designated factory.

**Engine check lamp**

When the start switch is set to the "I" position, self-diagnosis of the engine will start. When the result is normal. Three lamps will go out. If the lamp remains lit or it lights during operation, it means there is any trouble with the engine. Stop the machine to check the engine.

**★ ENGINE STOP, EGT. WARNING**

When the engine stop lamp or exhaust gas temperature warning lamp lights, it means a serious abnormality occurs with the engine. Stop the machine and the engine, and receive proper checking / maintenance or repairing.

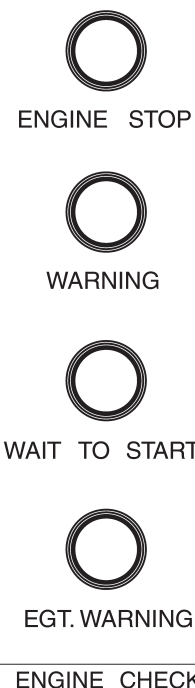
**★ WARNING**

When the warning lamp lights, water may be accumulated in the fuel pre-filter. Drain the fuel pre-filter. (See page 82)  
If the lamp lights just because the water is accumulated in the fuel pre-filter, it will go out after draining.  
If the lamp does not go out, the engine may be abnormal. Receive proper checking / maintenance or repairing before a serious failure occurs.

## 2. OPERATION

### ★ WAIT TO START

When the wait to start lamp is lit, it means self-diagnosis of the engine, and the engine should not be started.

Must wait to start the engine. The most common reason for this is to wait for the intake air heaters to complete a pre-heat cycle during cold ambient conditions.

### IMPORTANT

**For the details of the engine check lamp, see the instruction manual of the engine.**

### Auto Speed lamp

**Steady light** : Goes on when the “ AUTO SPEED ” is selected by pressing the “ AUTO SPEED ” button.

**Slow flicker** : Goes on when the “ AUTO SPEED ” is cancelled by pressing the “ AUTO SPEED ” button.

**Fast flicker** : Goes on when the either of “ IPF ” “ Propel speed ” “ Vibration frequency ” “ Vibration amplitude ” “ Engine speed ” position is changed while in the “ AUTO SPEED ” mode.



AUTO SPEED

### Exact compact meter

Impact frequency lamp  
The lamp flashes depending on the rolling speed and IPF setting.

Rolling speed  
or  
Error codes  
or  
Temperature Display

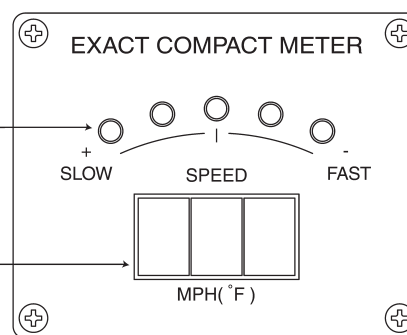



### 2.1.3 Switches

#### Starter switch

Starts and stops the engine.

"O" position : The key can be removed in this position.  
All the electric systems are switched off.  
To shut down the engine, move the key to this position.

"I" position : The charging circuit and lamp circuit are charged with electricity. Leave the key in this position after the engine has started.

START position: The engine is cranked and gets started.  
The moment the engine has started, release the key. It will automatically return to the "I" position.

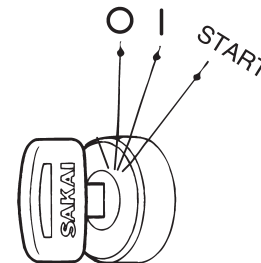

#### ⚠ CAUTION

**Set the forward-reverse (F-N-R) lever in the neutral position and press down the parking brake switch before starting the engine. Unless these conditions are met, the engine will not start.**

#### Lamp switch

- position : All lamps are switched off.
- ☞ position : Illuminates the dash panel and front lamps go on.
- ☞☞ position : All lamps are switched on.

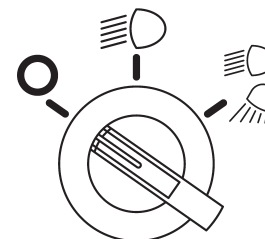

#### Engine speed selector switch

Selects engine speed.

IDLE position : Warm up the engine

MID position : Propel the machine (travel mode without vibration)

FULL position : Propel the machine with vibration

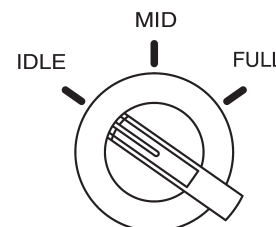

## 2. OPERATION

### Parking brake switch

If switch (P) is pressed down, the parking brake will be applied with the indicator lamp (P) on the monitor display lighted up.

When pressed again, the brake is released and the indicator lamp goes off.

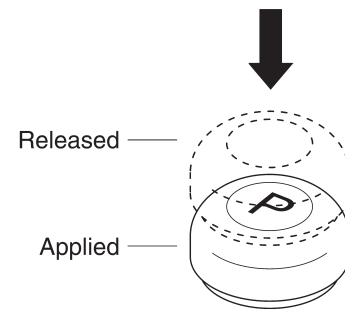

### ⚠ WARNING

- To disengage the brake, be sure to press the button again instead of pulling it.
- When dismounting from the machine, press the button to apply the brake without fail.

### ⚠ CAUTION

Never pull the switch up.

### IMPORTANT

In an emergency, depress the brake pedal.

### Horn switch button

Pressing the button at the center of the steering wheel makes the horn sound.

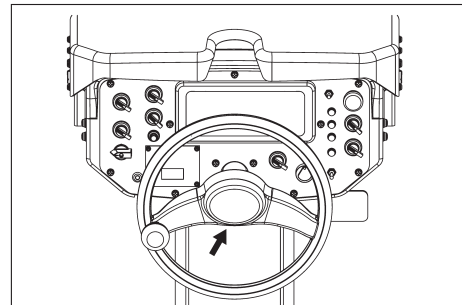

## Propel speed selector switch

Select mode according to propel condition.



position : Work condition

- The Auto speed function can be controlled with this mode. (See page 52)
- Maximum speed is regulated by each vibration frequency.

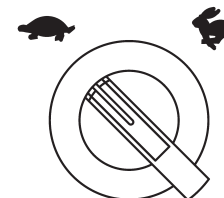

Frequency (vpm)	Propel speed mile / h (km / h)
2500	0 – 2.8 (0 – 4.5)
3000	0 – 3.4 (0 – 5.5)
4000	0 – 4.5 (0 – 7.2)



position : Traveling 0 – 6.8 mile / h (0 – 11 km / h)



**IMPORTANT**

**Be sure to shift gears while the machine is stopped. Cannot shift gears during operation.**

- NOTE:**
- Machine speed can be operated under at FULL position of Engine speed selector switch.  
Maximum speed is reference value.
  - Selection is applied only when the F-N-R lever is in the neutral position.

## 2. OPERATION

### Vibration mode selector switch

- "  " position : Vibration can be controlled by the vibration switch on the F-N-R lever
- "  " position : Vibration is shut off
- AUTO position: Vibration automatically engages when the F-N-R lever is moved into the forward or reverse

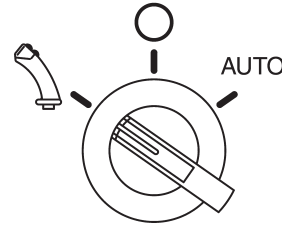



**NOTE:** For vibratory compaction, the “ Engine Speed ” selection switch must be in the FULL position.

The vibrator indicator lamp stays lit at all times when the machine is running in vibratory mode.

### IMPORTANT



- **Do not operate the vibrator on a hard area such as cement concrete pavement surface or the ground covered by thick steel sheets.**
- **Turn the vibrator off when the machine is at rest.**
- **Shut off the vibrator immediately if the machine gets stuck in the mud during vibratory operation.**

### Vibration drum selector switch

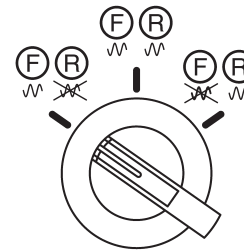
- "  " position : Only the front drum will vibrate
- "  " position : Both drums will vibrate
- "  " position : Only the rear drum will vibrate



### Vibration amplitude selector switch

- "  " position : Low amplitude vibration
- "  " position : High amplitude vibration

**NOTE:** Selection is applied only when the F-N-R lever is in the neutral position.

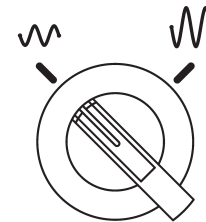

## 2. OPERATION

### Vibration frequency selector switch

- 2500 position : Vibration can be set at 2500 vpm in the low or high amplitude position.
- 3000 position : Vibration can be set at 3000 vpm in the low or high amplitude position.
- 4000 position : Vibration can be set at 4000 vpm in the low amplitude position only.  
Vibration will automatically be limited to 3000 vpm when high amplitude is selected, regardless of the frequency selection. This machine can not operate at 4000 vpm in high amplitude.

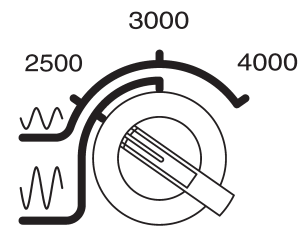

**NOTE:** Selection is applied only when the F-N-R lever is in the neutral position.

### Vibration switch

The vibration switch is integrated on the F-N-R lever. The green button toggles vibration “ on ” and “ off ”. When the green button is depressed the first time, vibration will turn on. When the green button is depressed a second time, vibration will shut off. The button must be depressed and held for one second in order to engage. It works only when “  ” is selected on the “ Vibration mode ” selector switch.

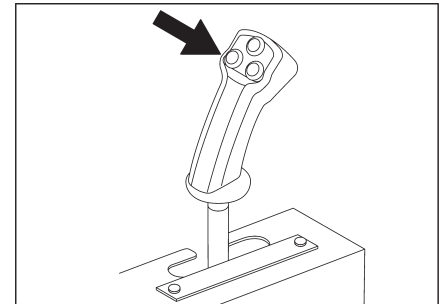

**NOTE:** For vibratory compaction, the “ Engine Speed ” selection switch must be in the FULL position.

The vibrator indicator lamp stays lit at all times when the machine is running in vibratory mode.

## 2. OPERATION

### IPF selector switch

The Number of Impacts Per Foot (IPF) can be selected for when using the “ EXACT COMPACT METER ”.

See 2.6 Exact Compact Operation Page 60

IPF number can be set at 10, 11, 12, 13, 14, 15.

**NOTE:** Selection is applied only when the F-N-R lever is in the neutral position.

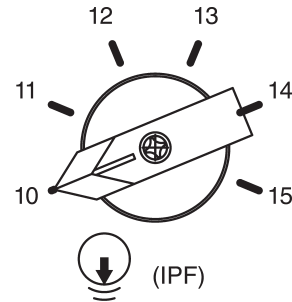

### Spray mode selector switch / Spray switch / Spray timer switch / Spray timer dial

#### Spray mode selector switch

"  " position : Spray system can be controlled by the blue button switch on the F-N-R lever.

"  " position : Spray system is shut off.

AUTO position: Spray system is actuated when the F-N-R lever is in the forward or reverse position and deactivated when the F-N-R lever is moved to the Neutral position.

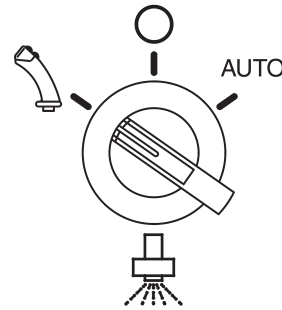

#### Spray switch

The spray sprinkler switch is integrated on the F-N-R lever. The blue button toggles the spray system on and off. Spray pumps will turn on when the blue button is depressed once and then turn off when the blue button is depressed a second time. Be sure to hold the button for at least one full second in order for it to engage.

It works only when the “ Spray mode selector switch ” is set in the “  ” position.

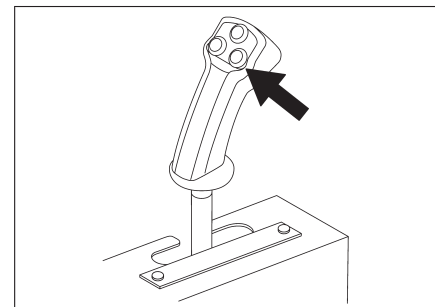

#### Spray timer switch

"  " position : Spray timer is activated

"  " position : Spray timer is shut off

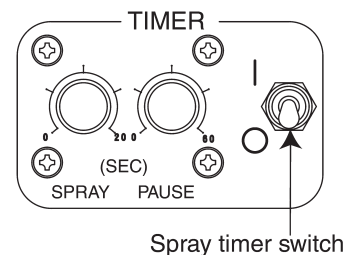

## 2. OPERATION

### Spray timer SPRAY dial

Spray time can be set from 0 – 20 seconds by turning this dial.

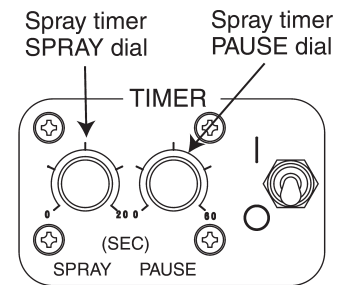

### Spray timer PAUSE dial

Sprinkling pause interval can be set from 0 – 60 seconds by turning this dial.

**NOTE:** The spray indicator lamp stays illuminated whenever water is spraying. In timer mode, the lamp will turn on (indicating spray) and off (indicating pause).

### Front spray pump selector switch

### Rear spray pump selector switch

There is a total of four spray bars on the SW Series rollers. Two spray bars on the front drum and two spray bars on the rear drum. Each spray bar has one water pump dedicated to it, for a total of four water pumps, one for each spray bar. When pump 1 is selected for either the front or rear drum, one spray bar is operational. When pump 2 is selected for either the front or rear drum, the second spray bar is operational. When “Both” is selected for either the front or rear drum, both spray bars operate, providing double the volume of water going to wet the drum. In most cases, only pump 1 or pump 2 is selected.

In a few situations, where a heavy application of water is required on the drum, such as in very windy and/or dry desert conditions, both pumps are used simultaneously.

When only one pump is required, it is recommended to alternate pumps so that they both wear evenly. Alternating pump use also helps to keep them in better operating condition by running water through them to keep the inside of the pump wet. For example, on a multi-day project, it is recommended to use pump 1 on the first day, pump 2 on the second day, and alternate each day.

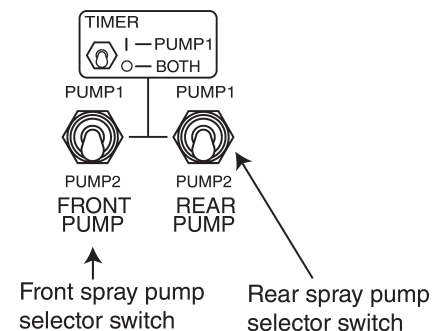

PUMP1 position : Actuate pump 1

Center position : Pump 1 when select intermittent spray

Pump 1 and pump 2 when deselect intermittent spray

PUMP2 position : Actuate pump 2

## 2. OPERATION

### Engine diagnostic switch

Engine troubleshooting can be conducted using the trouble code selector switch.

During normal operation, do not operate switches.

Set switch as shown in " O " position during the normal operation.

See 2.2.7 Engine diagnoses page 44 for detail.

" | " position : Engine diagnostic is activated

" O " position : Engine diagnostic is shut off



### IMPORTANT

**When operating the trouble code selector switch, see the engine manual.**

### Emergency propel switch

Propel the machine with this switch if the machine can't be propelled with F-N-R lever.

Sometimes called a "limp home" switch, this function will only work after MANUALLY plugging in the appropriate wire harness connection.

See 2.3.4 Traveling page 50 for the detailed procedure on how to plug in the wire harness.



### AUTO SPEED set switch

The AUTO SPEED set switch is the top button on the F-N-R lever.

The speed that the roller is traveling at when the button is depressed will be recorded into memory. The Button must be depressed and held for at least one second.

When auto speed is set, the machine will run at the preset speed when the F-N-R lever is moved to the full forward or full reverse position.

The auto speed memory is cancelled when the button is pushed a second time and held for one second or longer.

See 2.3.6 AUTO SPEED page 52 for full operational instructions.

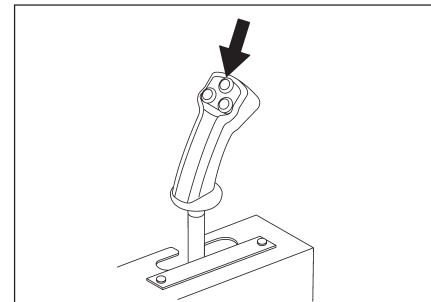



### 2.1.4 Operating levers / pedals

Forward-Neutral-Reverses lever (F-N-R lever) with AUTO SPEED / Vibration / Spray switch

Moving the F-N-R lever forward or backward makes the machine travel forward or backward respectively. The neutral position brings the machine to a stop. The machine speed increases or decreases in proportion to the lever displacement. AUTO SPEED / Vibration / Spray switches are integrated on this lever.

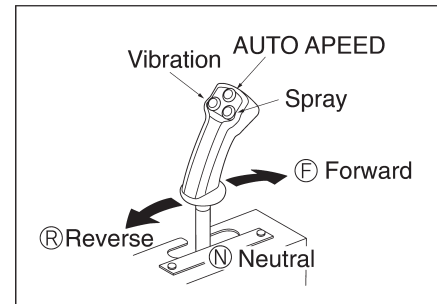

#### IMPORTANT

**In an emergency, depress the brake pedal.**

#### Brake pedal

In an emergency, press the brake pedal to the full extent, then the machine will stop suddenly together with its engine.

**NOTE:** The F-N-R lever must be in the neutral position to release the brake for the travel again.

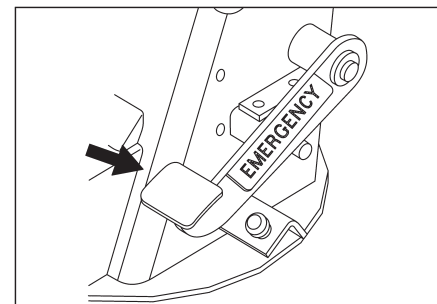

#### IMPORTANT

**Do not use the brake pedal for normal machine operation. Use only in an emergency. Use the F-N-R lever to stop the machine under normal operating conditions. Continuous use of the emergency brake pedal will damage the brake.**

## 2. OPERATION

### Unloader valve

The unloader valve disengages the drive, similar to a clutch. Use this valve for towing the machine when the engine is disabled or when trouble has developed in the hydraulic drive.

#### For towing

Turn the lock knob counter – clockwise, then turn the hand knob counter – clockwise fully. It is now in the UNLOAD position.

#### For normal traveling

Make sure the lock knob is turned counter - clockwise fully, then turn the hand knob clockwise fully, than turn the lock knob clockwise to lock the handle. It is now in the ONLOAD position.

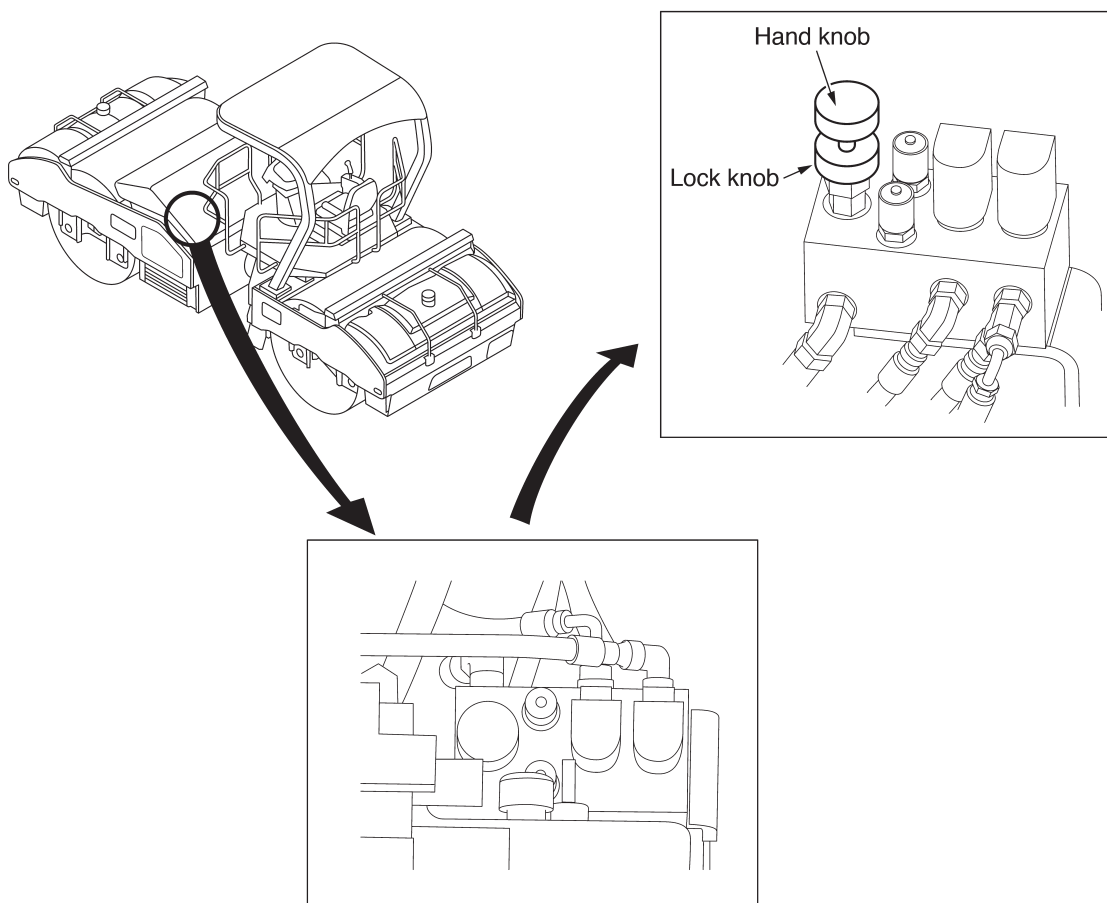

### **⚠ WARNING**

- On a slope, chock the wheels and use extreme care when using the unloader valve and towing the machine.
- Be sure to apply the parking brake when operating the unloader valve.
- Unloading the unloader valve will disengage the engine, so never get in front of or behind the machine.

**NOTE:** For normal travel, be sure that the unloader valve is in the ONLOAD position.

### 2.1.5 Fuse box and Line fuse

#### **⚠ WARNING**

**When changing a fuse, cut the power supply by turning the starter switch to the "○" position.**

Fuses protect electrical components and wiring from burning. Change any fuse which has become powder-coated due to deterioration or which has play between it and fuse holder. To replace fuses, take off the cover. Be sure to use fuses of correct capacity.

Using improperly rated fuses may result in poor machine performance, damage to the electrical system, or safety problems, such as an electrical fire.

See page 102 for location.

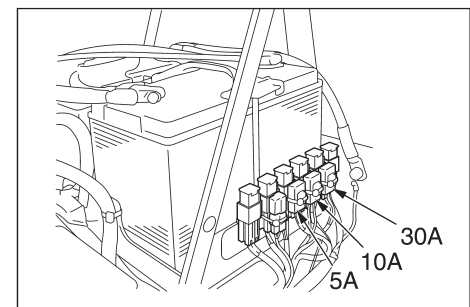
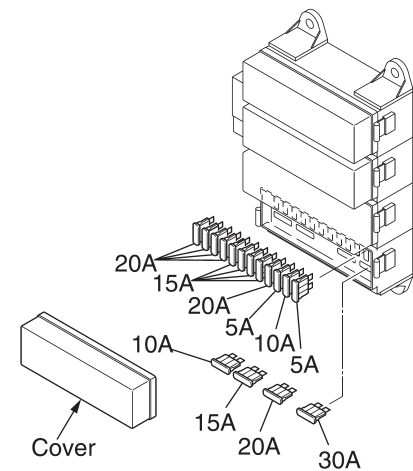

## 2.2 Handling and Adjustments

### 2.2.1 Seat adjustment

Adjust the seat for your best operating position. Move the lever as shown by arrow. With the lever held in that position, slide the seat forward or backward as desired. When properly adjusted, release the lever.

Adjust your seat position to suit you as follows:

- 1) Pull the lever ① and adjust seat position longitudinally.
- 2) Turn the backrest adjust pull the lever ② for optimum angle.
- 3) Move the suspension lever ③ to select suitable suspension for your body weight.

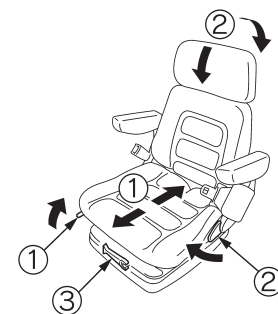

## 2. OPERATION

### ⚠ WARNING

- The seat shall be adjusted before starting any works or when the driver is switched over the other person while the machine is completely stopped.
- Do not adjust the seat while the machine is in motion.
- Some unexpected troubles may be accidentally caused if moving the machine without completely fixing the seat such as while sliding the seat. Before moving the machine, make certain that the seat is completely fixed after making proper adjustments.
- Do not pinch your fingers, hands or legs while adjusting the seat.
- Adjust seat only when one person rides on the machine.
- Adjust seat only when the machine stays on the flat ground.
- Adjust the seat so that your back is in close contact with the back of the seat while seated and when stepping on the brake pedal down to the floor. Adjust the seat so as to be able to certainly step on the brake pedal when twisting your body around to look back in order to move the machine backwards.

### IMPORTANT

Be sure to wear the seatbelt during operation.

## 2.2.2 Scraper adjustment and replacement

### Scraper

Adjusting the gap between scraper blade (a) and drum.

- 1) Loosen lock nuts (b) at 2 locations and nuts (c) at 7 locations.
- 2) Adjust scraper blade (a) to eliminate the clearance between scraper blade (a) and drum.
- 3) Tighten nuts (c).
- 4) Make fine adjustment of the gap between scraper blade (a) and drum by set bolt (d).
- 5) Tighten lock nuts (b).

### Replacing the scraper blade

- 1) Remove bolts and nuts (c) at 7 locations.
- 2) Replace scraper blade (a) with new one.
- 3) Reinstall and tighten the bolts and nuts (c).

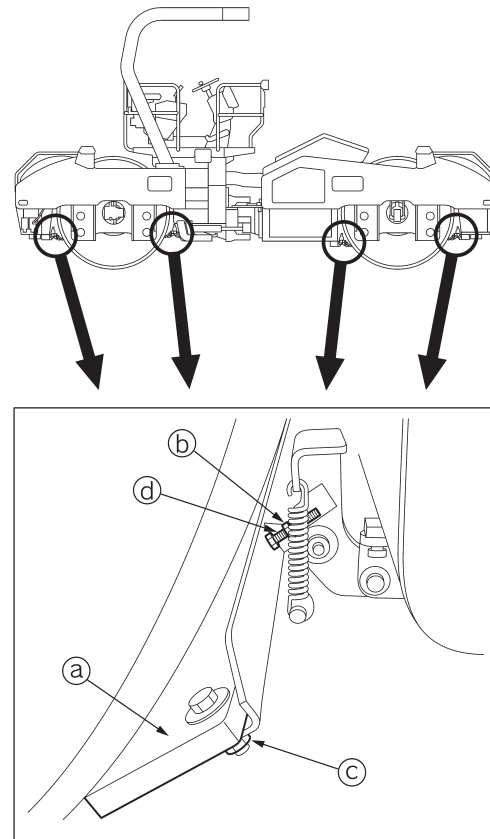

## 2.2.3 Disengaging the brake when towing

**⚠ WARNING**

**On a slope, chock the drums and prepare for towing before disengaging the brake.**

For towing the machine when the engine is disabled or when trouble has developed in the hydraulic propulsion system, disengage the brake as instructed below:

Use the same procedure for both front and rear drums.

- 1) Remove the brake-disengaging bolts and washers (two each) from the machine frame.

Brake-disengaging bolts and washers (red)

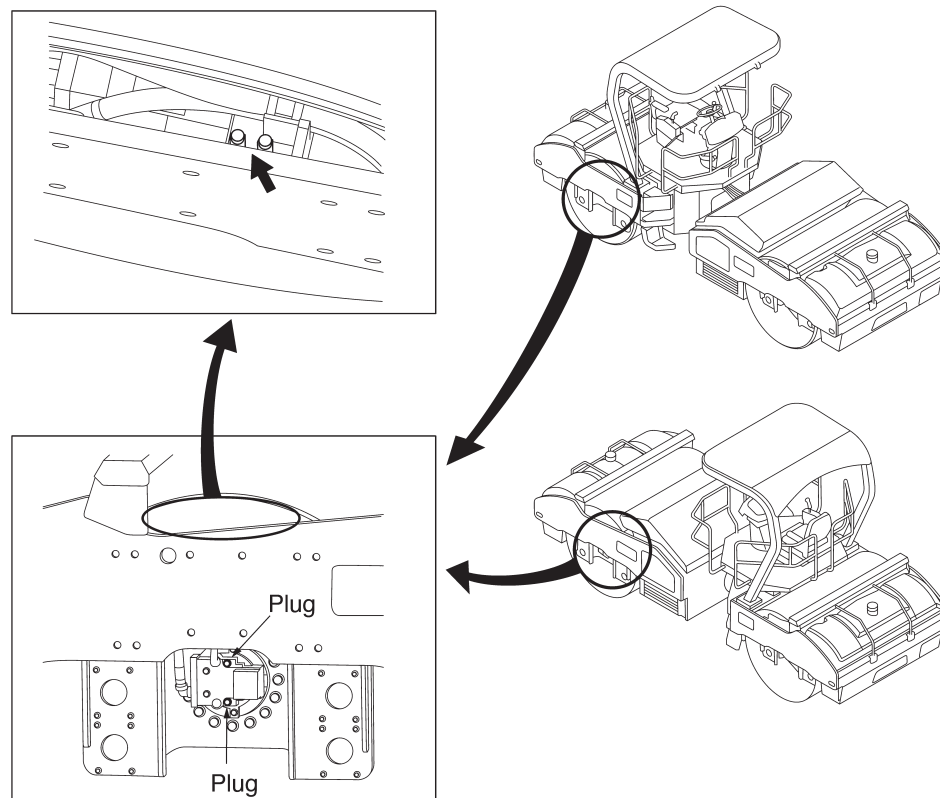
**⚠ WARNING**

- Do not try to release the brake immediately after a hot engine has been stopped. Let the oil cool down.
- For the brake disengagement, wear hard hat and safety goggles and protector glove.



## 2. OPERATION

2) Remove the plugs (2 locations) from the motor.

**NOTE:** Conduct the work rapidly, as the oil will gush out when the plugs are taken off.

3) Screw in the removed bolts with the washers into the plug holes. Screwing in them until they become a little tight will disengage the brake.

**NOTE:** Wash clean the brake release bolts and blank plugs before fitting to the motors.

4) After towing, replace the bolt and washer to original position and tighten the plug securely to the motor.

### 2.2.4 Steering wheel position adjustment

- 1) Pull the lever **(a)** upward. Doing so disengages the lock off the wheel.
- 2) Position the wheel for your operating comfort.
- 3) Lower the lever **(a)** to lock the wheel in place.

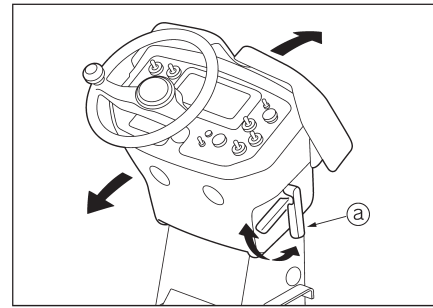

## 2. OPERATION

### 2.2.5 Operator's platform position adjustment

Operator's platform rotates by 60 and 90 degrees, clockwise or counterclock – wise.

Set it at the desired angle to allow you to easily see the drum edge during work.

- 1) While depressing the swivel pedal (b), rotate the operator's platform by pushing or pulling with your other foot.
- 2) As soon as it starts rotating, release the swivel pedal (b) and continue to push the operator's platform at 60 degrees, it will automatically lock into position.
- 3) Continuing the same action while depressing the swivel lever (b) will allow the operator's platform to lock automatically at 90 degrees.

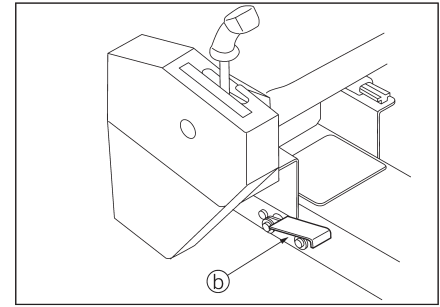

#### **⚠ WARNING**

**Make sure the operator's platform is completely locked in place before continuing to operate the machine. If the operator's platform is not locked in place, it could unexpectedly rotate during operation and cause the operator to lose control of the machine and result in an accident with the potential for injury or death.**

#### **⚠ CAUTION**

**Sit down on the seat during this operation for your safety.**

### 2.2.6 Step for maintenance of engine room

#### **⚠ WARNING**

**Withstand load 130kg (286lbs).**

#### **⚠ CAUTION**

**Keep closed to the step when during the operation.**

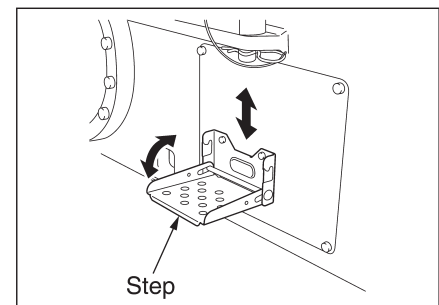

## 2. OPERATION

### 2.2.7 Engine diagnoses

Engine troubleshooting can be conducted using the trouble code selector switch.

During normal operation, do not operate switches.

Set switch as shown in "○" position during the normal operation.

" | " position : Engine diagnostic is activated

" ○ " position : Engine diagnostic is shut off

Engine diagnostic

- 1) Turn the starter key to the "○" position to stop the engine.
- 2) Set Engine diagnostic switch as shown in " | " position.
- 3) Turn the starter switch to the " | " position to on the monitor display.



ENGINE STOP



WARNING



WAIT TO START



EGT. WARNING

ENGINE CHECK

- No fault codes recorded  
Light up the engine stop lamp and warning lamp.
- Fault codes recorded  
Light up at shining moment the Engine stop lamp and warning lamp. Then flash the Engine stop lamp or warning lamp.

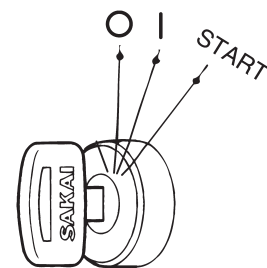

### IMPORTANT

- When operating the trouble code selector switch, see the engine manual.
- When the engine malfunctions or fails, contact your SAKAI Dealer immediately for appropriate inspection, maintenance, or repair.



## 2.3 Operation

### ⚠ WARNING

- This machine is a one-man roller.
- Operate the machine from the operator's seat.
- Be sure to wear the seatbelt during operation.

### 2.3.1 Before-starting inspection

- 1) Check that the steering lock bar is in the carrying position.

### ⚠ WARNING

Make sure that the steering lock bar is connected in the carrying position before putting the machine in motion. Steering is impossible if the bar is in the steering lock position.

The bar is located at the right of the center of the machine.

To unlock the bar

- ① Remove the spring pin.
- ② Pull out the lock pin.
- ③ Set the bar in the carrying position.
- ④ Retain the lock bar in the locked position by inserting the lock pin into the lock holes.
- ⑤ Secure the lock pin with the spring pin.

- 2) Check that the F-N-R lever is in the neutral position (N).

- 3) Confirm that the parking brake is engaged.

**NOTE:** When the F-N-R lever is not in the neutral (middle) position, or the parking brake has been released, the interlocking system goes into operation and the engine will not turn on. Be sure to confirm that the F-N-R lever is in the neutral (middle) position, and that the parking brake is engaged before starting the engine.

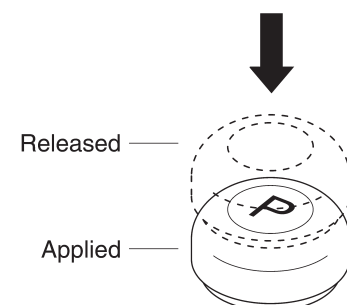
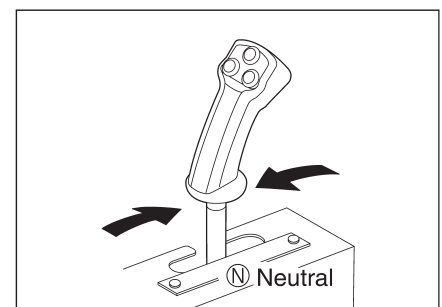
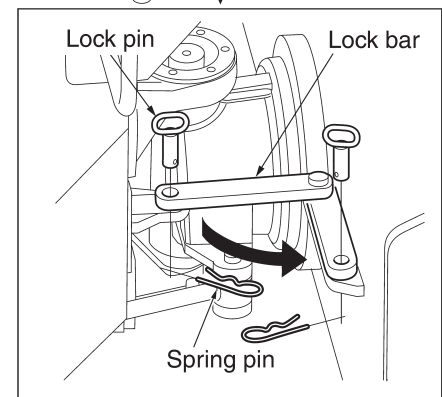
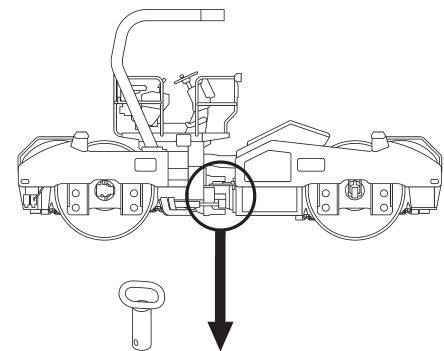

## 2. OPERATION

### 2.3.2 Starting the engine

#### **⚠ WARNING**

- Check that there are no people or obstacles around the machine and beep the horn before starting the engine.
- Set the Forward-Neutral-Reverse (F-N-R) lever in the neutral position and press down the parking brake switch before starting the engine.  
Unless these conditions are met, the engine will not start.

1) Select IDLE position of Engine speed selector switch.

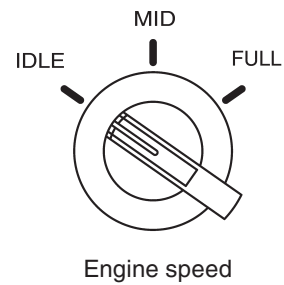

2) Turn the starter switch to the " I " position and check that the warning lamps and parking brake indicator lamp on the monitor display are on.

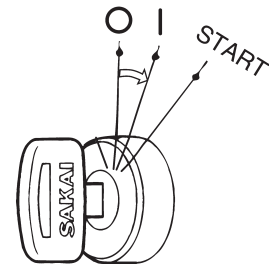
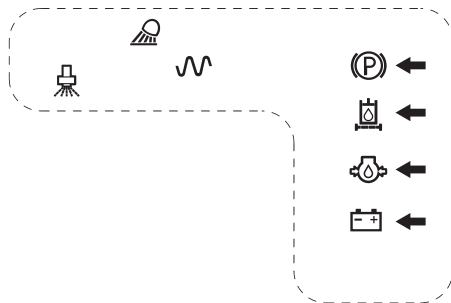

3) Start the engine after the engine check lamp lights up and goes out.



- 4) Turning the key to the START position makes the engine start. Release the key the moment the engine has started. The key will automatically return to " I " position.

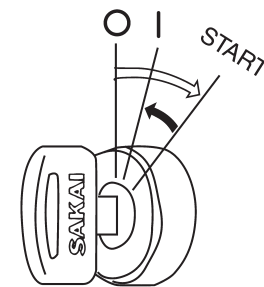

**⚠ CAUTION**

- Do not allow the starter key to stay in the START position for more than 15 seconds.
- When the engine fails to start, or you want to restart the engine immediately after turning it off, wait around 30 seconds before restarting it.
- If the engine does not start, allow an interval before trying again.
- Check that the warning lamps on the monitor display go off immediately after the engine is started. If any of these warning lamps stay on while the engine is running, shut down the machine, determine the cause and rectify the fault.

**2.3.3 After starting the engine**

Try not to move the machine immediately after starting but practice the following:

**IMPORTANT**

**Avoid increasing the engine speed abruptly before warming-up run is completed.**

- 1) Run the engine at idling for about 5 minutes to warm it up. Warming-up run allows the lubricating oil to reach the vital parts of the engine and hydraulic system, gradually warm the engine, engine oil and hydraulic oil to prepare the machine for driving.
- 2) After the warm-up operation, check that:
  - Temperature gauge .....Pointer falls near the center zone
  - Fuel gauge .....Pointer falls between the E and F marks
  - Charge lamp .....Has gone off
  - Engine oil pressure warning lamp .....Has gone off
  - Engine check lamp .....Has gone off
- 3) Check for the color of exhaust gas, listen for unusual sounds and vibration. If abnormal, determine the cause and correct the problem.

**⚠ WARNING**

**Stay in the driver seat during operation.**

## 2. OPERATION

### 2.3.4 Traveling

#### ⚠ CAUTION

While travelling, do not turn the starter switch "○".

#### ⚠ WARNING

- When starting, operate the horn after securing the safety around the machine.
- Be sure to wear the seatbelt during operation.

1) Select mode according to propel condition.

 position : Work condition

- The AUTO SPEED function can be controlled with this mode. (See page 52)
- Maximum speed is regulated by each vibration frequency.

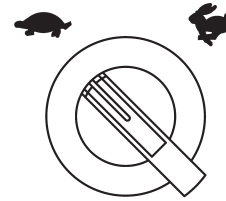

Frequency (vpm)	Propel speed mile / h (km / h)
2500	0 – 2.8 (0 – 4.5)
3000	0 – 3.4 (0 – 5.5)
4000	0 – 4.5 (0 – 7.2)

At FULL position of Engine speed selector switch.

 position : Traveling condition 0 – 6.8 mile / h. (0 – 11 km / h)

**NOTE:** Selection is applied only when the F-N-R lever is in the neutral position.

#### IMPORTANT

Be sure to shift gears while the machine is stopped. Can not shift gear during running.

#### ⚠ WARNING

On a steep slope, run the machine at low speed.

2) Select MID or FULL position of Engine speed selector switch.

**NOTE:** Machine speed can be operated under at FULL position of Engine speed selector switch. Maximum speed is reference value.

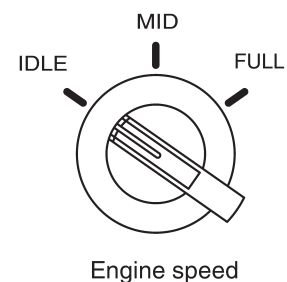

## 2. OPERATION

- 3) Press down the parking brake switch button to release the brake. Check that indicator lamp (P) on the monitor display goes off.

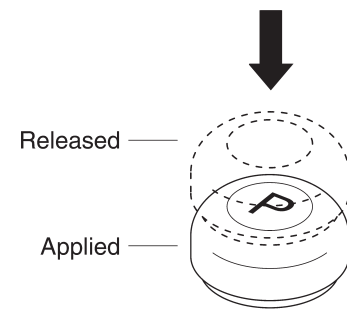

- 4) Move the F-N-R lever in the direction to travel, and the machine will begin traveling.

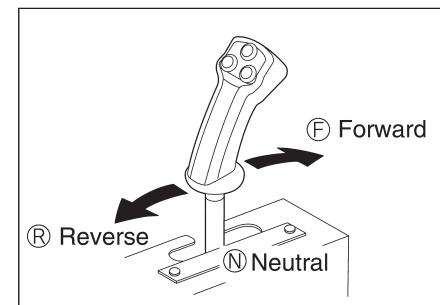

**NOTE:** The travel speed can be controlled by the engine speed select switch and F-N-R lever.

**⚠ CAUTION**  
Avoid abrupt operation of the F-N-R lever.

- ⚠ WARNING**
- Pay extreme attention to the area behind the machine when backing, since the space just behind it tends to be a blind spot.
  - Pay careful attention to your surroundings and maintain control of the machine when changing switch positions. Whenever possible, stop the machine to change switch settings before continuing operation.

## 2. OPERATION

### Emergency traveling

If the machine doesn't move when you operate the forward and reverse control lever while the engine is running, there maybe a problem with the control system.

In this case, you may bypass the controller to temporarily drive the machine by following the procedure below.

- 1) Push on the parking brake. Shut off the engine and make sure the emergency propel switch is in the neutral position.

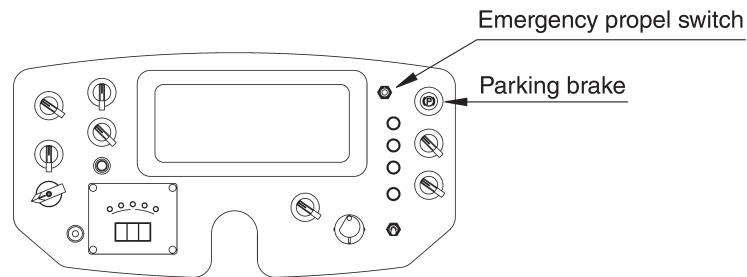

- 2) Identify the connectors " PRO " & " EME " between the valve blocks on the left side of the machine.

- 3) Remove the plugs from connector " PRO " then exchange connectors " PRO " and " EME ".

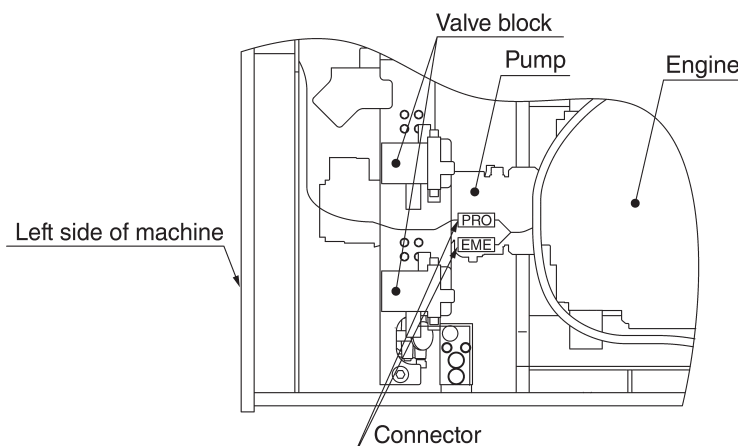

- 4) Make sure the connectors are properly connected, close the hood but do not start the engine until you have checked the surrounding area for obstacles. Also make sure that the emergency switch and traveling direction of the machine are the same. Now it will be safe to move the machine to a safe area.

If the machine will not move at this point there are other problems. You will have to tow the machine to safe area.

When you exchange connectors again, follow the procedure below.

- Push on the parking brake.
- Shut off the engine.
- Be sure the F-N-R lever is in neutral.
- Contact your servicing dealer.

**IMPORTANT**

Contact your Sakai Dealer to service the machine, after the machine is transported to a safe place.

## 2.3.5 Stopping and parking

**⚠ WARNING**

- Avoid abrupt braking. Try to leave enough time for braking.
- Avoid parking on a grade.
- If necessary to park on a grade, block the drums to prevent unexpected moving down the grade.

- 1) Bring the F-N-R lever to the neutral position (N), and the machine will come to a halt.

**⚠ CAUTION**

The normal operation can be performed by using the F-N-R lever, but step on the brake pedal in case of emergencies.

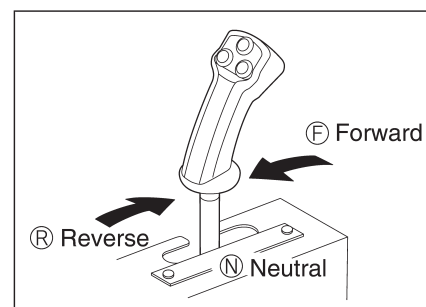
**IMPORTANT**

After depressing the brake pedal, return the F-N-R lever to the neutral position, otherwise the machine will not start.

- 2) Press the parking switch button securely, and check that indicator lamp (P) illuminates.

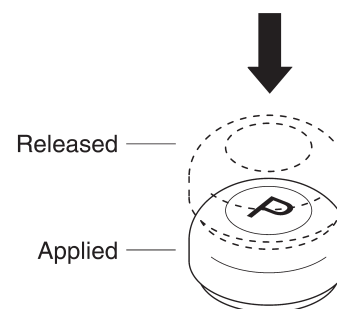

## 2. OPERATION

### 2.3.6 AUTO SPEED

#### 2.3.6.1 Setting

The machine propel speed can be memorized by the machine controller and the speed is controlled automatically. It will help to easily control your speed to a preset value when a certain speed is required on the work site.

**NOTE:** The AUTO SPEED function only operates when the Engine Speed selection switch is set to FULL and the Propel speed selection is in the “” position.

**NOTE:** The minimum allowable AUTO SPEED setting is 1.5 miles per hour.

- 1) With the machine in moving at the desired AUTO SPEED setting, press the TOP button on the F-N-R lever and hold for at least one second to set the AUTO SPEED equal to the current machine speed.

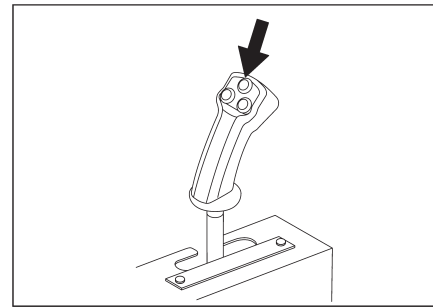

- 2) Check the AUTO SPEED lamp  
If the AUTO SPEED is successfully set up in Step 1, the AUTO SPEED lamp will remain lit. If the lamp is not illuminated, repeat Step 1.



AUTO SPEED

- 3) After setting the AUTO SPEED in Step 1, move the F-N-R lever to the neutral position (N).  
The AUTO SPEED feature is now set so that the machine will travel at the preset speed when the F-N-R lever is in the full forward or full reverse position.

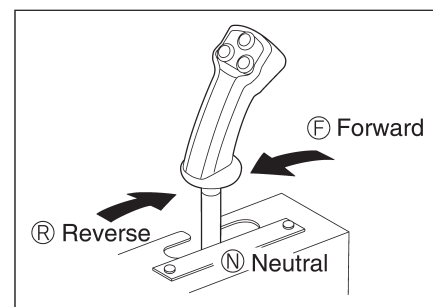

#### CAUTION

**Do not change the IPF / Vibration Frequency / Vibration Amplitude / Propel Speed / Engine Speed switch setting after setting the AUTO SPEED without first canceling the AUTO SPEED. Doing this will cause the AUTO SPEED lamp flicker until the IPF / Vibration Frequency / Vibration Amplitude / Propel Speed / Engine Speed switch is set back to the position it was in when AUTO SPEED was set.**



### 2.3.6.2 Canceling AUTO SPEED

- 1) Press and hold the Top button on the F-N-R lever for at least one second when the AUTO SPEED lamp is lighted on.
- 2) Check the AUTO SPEED lamp.  
It is ready to cancel the AUTO SPEED, the lamp will flicker. If the lamp is not flickering, press the Top button again and hold for at least one second.
- 3) Move back the F-N-R lever to neutral position (N).  
AUTO SPEED is cancelled after the machine stops.
- 4) Check the AUTO SPEED lamp.  
When the AUTO SPEED is cancelled completely, the lamp goes off.

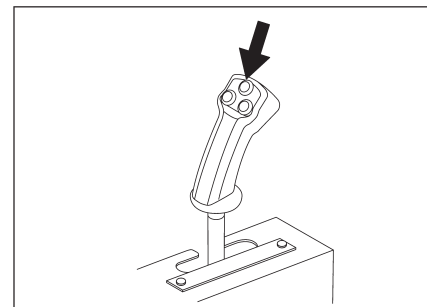

AUTO SPEED

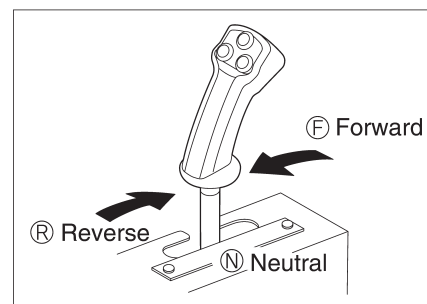

#### **⚠ CAUTION**

**Move the F-N-R lever slowly at first after the AUTO SPEED feature has been canceled because the machine response will be faster now.**

## 2. OPERATION

### 2.3.7 Stopping the engine

- 1) Set the engine speed select switch at the IDLE position, wait for about 5 minutes with the engine idling to gradually cool the engine.

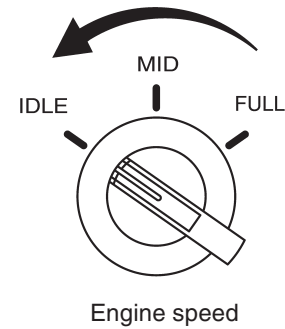

#### IMPORTANT

- Do not bring a hot engine to a sudden stop except for an emergency. This will shorten the life of its component parts.
- Do not allow an overheated engine to come to a sudden stop, but run it at middle idling speed for gradual cooling down.

- 2) Turn the starter key to the "O" position to stop the engine.

#### CAUTION

Do not turn the starter switch "O" while the machine is in motion.

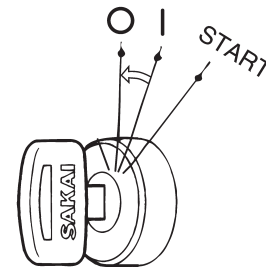

- 3) Remove the ignition key.

#### WARNING

- When dismounting from the machine, apply the brake by pressing the parking switch button. If necessary to park on a grade, block the wheels to prevent unexpected moving down the grade.
- Never fail to remove the starter key.

### 2.3.8 Check after stopping the engine

- 1) Perform the walk-around checks for oil and water leakage, abnormal signs around the drums.
- 2) Fill the fuel tank.
- 3) Remove waste paper if any from the engine compartment, as this will pose a possible fire hazard.
- 4) Scrape mud or other materials from and around the drums
- 5) When transporting the machines, please ensure safety by strictly complying with the applicable laws and regulations.

## 2.4 Vibratory Operation

- 1) Select FULL position of Engine speed selector switch.  
Appropriate vibration force is engaged when the Engine Speed selector is in the FULL position.

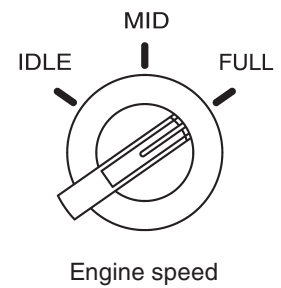

- 2) Select  or AUTO position of Vibration mode selector switch.

 position : Vibration can be controlled by the vibration switch on the F-N-R lever

AUTO position : Vibration is automatically engaged when the F-N-R lever is moved into the forward or reverse positions

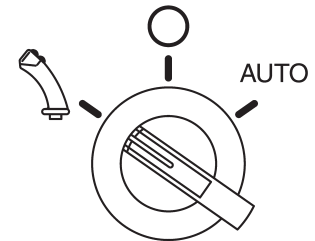

- 3) Select Vibration drum of Vibration drum selector switch.

 position : Only the front drum will vibrate

 position : Both drums will vibrate

 position : Only the rear drum will vibrate

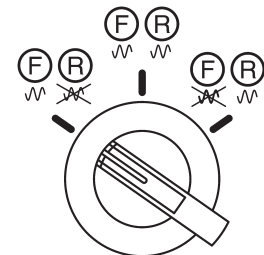

- 4) Select Vibration amplitude

 position : Low amplitude vibration

 position : High amplitude vibration

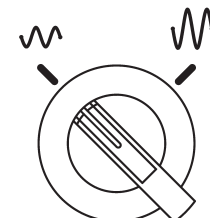

**NOTE:** Selection is applied only when the F-N-R lever is in the neutral position.

## 2. OPERATION

### 5) Select Vibration frequency.

2500 position : Vibration can be generated at 2500 vpm at low or high amplitude.

3000 position : Vibration can be generated at 3000 vpm at low or high amplitude.

4000 position : Vibration can be generated at 4000 vpm only in the low amplitude setting.

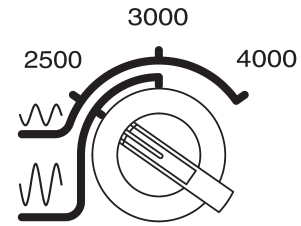

- NOTE:**
- If 4000vpm is selected and the machine is set on the high amplitude, it will default to operating in high amplitude at a frequency of 3000 vpm.
  - Selection is applied only when the F-N-R lever is in the neutral position.

### 6) Select Impacts per Foot using the IPF selector switch.

Number of Impacts Per Foot is selected as an input value for the “ EXACT COMPACT METER ”.

See 2.6 Exact Compact Operation page 52

IPF number can be selected from 10, 11, 12, 13, 14, 15

The green lights on the EXACT COMPACT METER will light up when the machine speed matches the desired IPF number.

See 2.6 EXACT COMPACT Operation page 60 for more details.

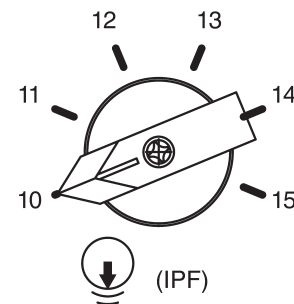

- NOTE:** Selection is applied only when the F-N-R lever is in the neutral position.

### 7) To generate vibration.

When the AUTO mode is enabled as described in Step 2 above, placing the F-N-R lever in the Forward or Reverse positions will cause the vibration to engage automatically when the machine starts in motion.

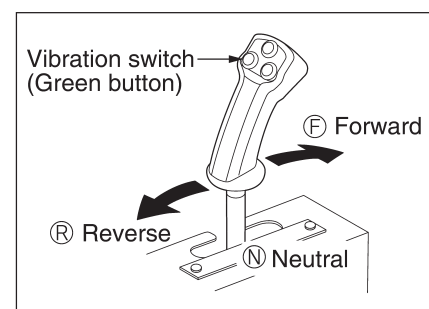

- NOTE:** Vibration can not be controlled by the vibration switch on the F-N-R lever in Auto speed mode.

When  position is selected in Step 2, press and hold the vibration switch (green button) for at least one second to start vibration. The vibration indicator lamp on the F-N-R lever will illuminate.

To shut off vibration, press and hold the vibration switch (green button) on the F-N-R lever for at least one second. The vibration indicator lamp will shut off when no vibration is occurring.

**⚠ CAUTION**

- Keep the vibrator shut off when the machine is not rolling.
- Stop vibration if the machine has encountered a running difficulty, for example, when it gets stuck in the mud.

**⚠ WARNING**

Pay careful attention to your surroundings and maintain control of the machine when changing switch positions. Whenever possible, stop the machine to change switch settings before continuing operation.

## 2.5 Water Spray System

- 1) Before turning the spray system on, check level in the water tank with the sight gauge. Add water as necessary.

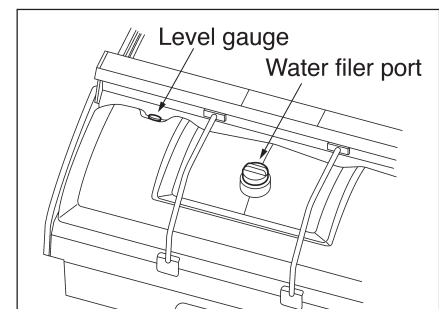

**IMPORTANT**

Use clean water wherever practicable.

- 2) Select  or AUTO position of Spray mode selector switch.

 position : Spray system can be controlled by the blue button switch on the F-N-R lever

 position : Spray system is shut off

AUTO position : Spray system is actuated when the F-N-R lever is in the forward or reverse position and deactivated when the F-N-R lever is moved to the Neutral position

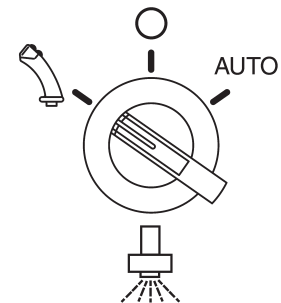

- 3) Select water pumps for front and rear drums.

Two each of same water pumps are installed to front drum and rear drum spray system. There are three positions at each switch.

PUMP1 position : Actuate pump 1

Center position : Pump 1 when select intermittent spray (see 4)

Pump 1 and Pump 2 when deselect intermittent spray (see 4)

PUMP2 position : Actuate pump 2

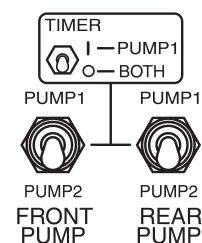

## 2. OPERATION

4) Select I position of timer switch for intermittent spray.

" I " position : Spray timer is activated

" O " position : Spray timer is shut off

5) Adjust spray time and pause time.

Spray time is adjustable between 0 – 20 seconds using the SPRAY Dial and pause time is adjustable between 0 – 60 seconds with PAUSE Dial as desired.

Adjust according to the job site conditions.

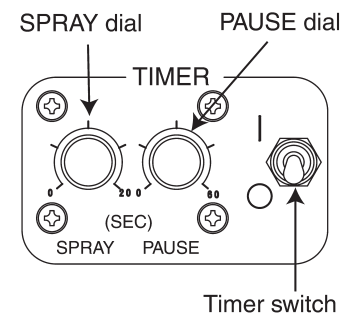

6) To start spraying.

When AUTO position is selected, placing the F-N-R lever in the Forward or Reverse position causes travel and sprinkling to start simultaneously.

**NOTE:** The water can not be controlled by the spray switch.

When  position is selected, press the spray switch (blue button) and hold for at least one second and the system will start spraying. The spray lamp will illuminate.

Pressing and holding the spray switch (blue button) for at least one second while the system is spraying will cause the sprinkling to stop.

The spray indicator lamp will turn off.

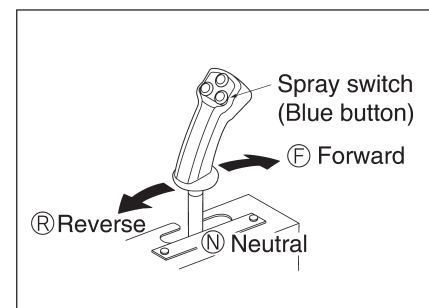

### IMPORTANT

**When starting asphalt compaction, place the spray switch in the  position and moisten the drum surface completely before selecting TIMER spray. For resuming work after a short break, follow the same procedure.**

### ⚠ WARNING

**Pay careful attention to your surroundings and maintain control of the machine when changing switch positions. Whenever possible, stop the machine to change switch settings before continuing operation.**

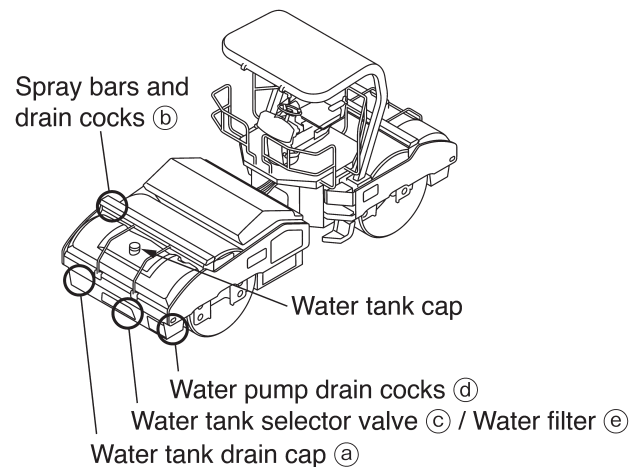
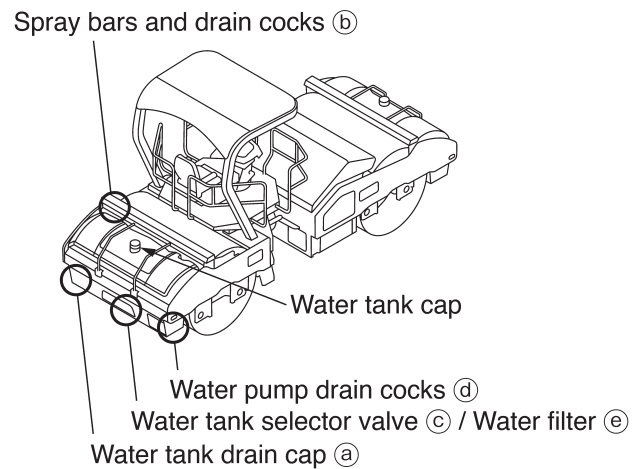
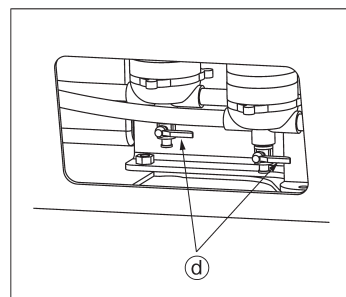
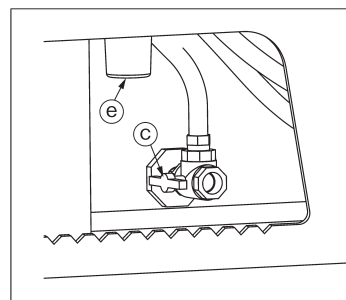
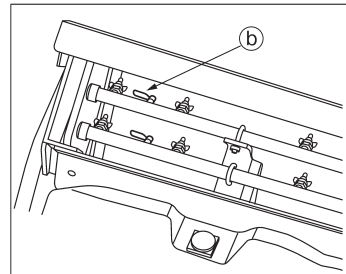
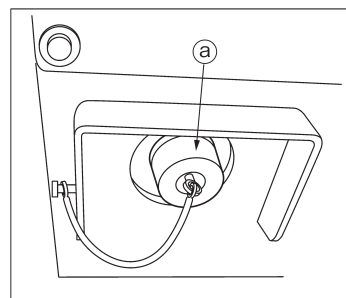

### To drain water

- 1) Take off the caps of water tanks.
- 2) Take off the drain caps (a) of water tanks and drain water from the tanks completely.
- 3) Open drain cocks (b) of spray bars at front and rear, to drain water completely.
- 4) Turn the lever of water tank selector valve (c) clockwise, open the drain cocks (d) of water pumps.  
Take off the bowl (e) from water filters then throw away water in the bowl then put the bowl back on the water filters.
- 5) Run the water pumps approximately 30 seconds with the drain cocks open.
- 6) Make sure water is completely drained from all hoses, water pumps and spray nozzles.

### ⚠ CAUTION

- To avoid freezing, fully drain the water tank, pipes and filters in cold weather.
- Pay attention to the water level because turning the pump with an empty water tank will damage the pumps.

## 2. OPERATION

### 2.6 EXACT COMPACT Operation (Impact Space Indicator & Speed Meter)

#### 2.6.1 Function

- 1) Indicates if the roller is achieving the desired number of impacts per foot based on the inputs of rolling speed and the operating frequency of the roller. The information is visually displayed by yellow, green, and red LED lights.
- 2) Indicates the rolling speed.
- 3) Indicates the error codes of the machine controller.
- 4) Indicates the rolling surface temperature. (OPTION)

#### 2.6.2 Operating instruction

##### IPF selector switch

The desired number of Impacts Per Foot can be selected as an input for the EXACT COMPACT METER.

IPF number can be selected from 10, 11, 12, 13, 14, 15.

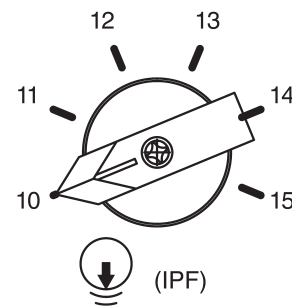

**NOTE:** Selection is applied only when the F-N-R lever is in the neutral position.

##### Display

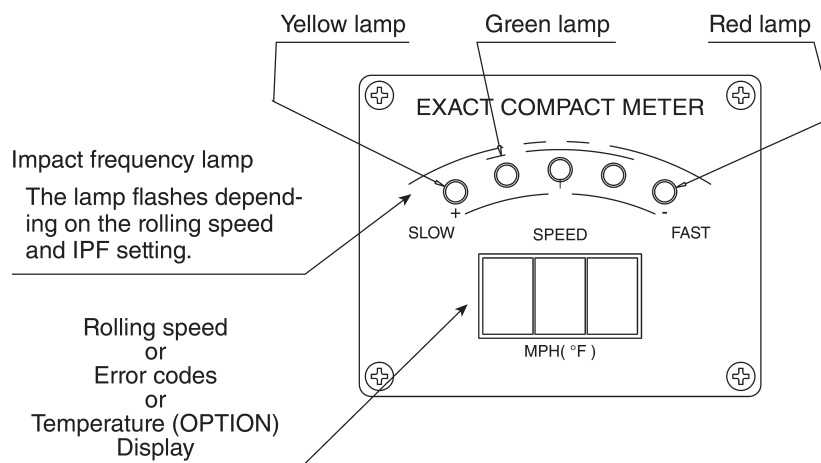



## 1) Impact frequency lamp

The position where the impact frequency lamp flashes, indicates whether actual impact frequency is greater or fewer than the preset IPF.

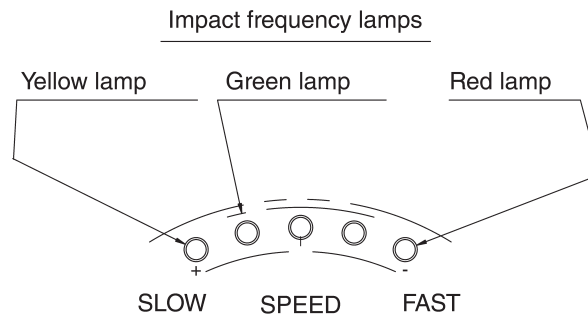

- Yellow light :  $+3 < \text{Difference comparing to IPF numbers}$   
 Left green light :  $+1 < \text{Difference comparing to IPF numbers} \leq +3$   
 Center green light :  $-1 \leq \text{Difference comparing to IPF numbers} \leq +1$   
 Right green light :  $-3 \leq \text{Difference comparing to IPF numbers} < -1$   
 Red light :  $\text{Difference comparing to IPF numbers} < -3$

## 2) Rolling speed / Error codes / Temperature display

When the ignition key is turned to the ON position, PON shows up for approximate 2 seconds.

After that, the rolling speed is displayed. If there is an error in the system, the error code is displayed.

Temperature is displayed when the Temperature / Machines speed selector switch is selected to F position. ( **NOTE:** Temperature display function is OPTIONAL)

## 2. OPERATION

### 2.6.3 Operation

- 1) When the ignition is turned to the “ ON ” position, the rolling speed display shows [0.0] after approximate 2 seconds. If the display shows any other message, there may be problems.  
See page 63 for detail.
- 2) Select the desired frequency from 2500vpm, 3000vpm, or 4000vpm by means of Vibration frequency selector switch.
- 3) Select the desired impacts per foot from 10, 11, 12, 13, 14, 15 IPF by means of the IPF selector switch.
- 4) When the machine travels with vibration on, the illuminated color of the impact frequency lamp moves in accordance with the rolling speed and the impacts per foot selection.
- 5) In order to execute compaction work at the desired vibration frequency and IPF setting, the work should be performed at the rolling speed where the center green light stays illuminated.
- 6) Using the AUTO SPEED function (See page 52) will assist compaction work.  
Following table shows reference with Frequency / I.P.F./ Propel speed.

Frequency (vpm)	I.P.F. (MPH)					
	10	11	12	13	14	15
2500	2.8	2.6	2.4	2.2	2.0	1.9
3000	3.4	3.1	2.8	2.6	2.4	2.3
4000	4.5	4.1	3.8	3.5	3.2	3.0

**NOTE:** Increase the rolling speed when Yellow light is illuminated.  
Reduce the rolling speed when the Red light is illuminated.

#### **⚠ CAUTION**

- When using the Exact Compact meter in vibratory mode, be sure to run the engine at FULL engine speed.
- If the engine is not running at the FULL speed position, the Exact Compact meter may display inaccurate results.

### 2.7 Machine Controller Diagnoses

If error code like as “ E XX ” is displayed on the EXACT COMPACT METER, some kind of error has been detected.

#### **⚠ CAUTION**

**When an error is detected, the engine may stop to urgently stop the machine.**

## 2. OPERATION

Error code	Function / Component	Error	Engine stop
E01	Potential meter	Output voltage to machine controller is grounded	Yes
E02	Potential meter	Output voltage to machine controller is power supply voltage	Yes
E03	Forward switch / F-N-R lever	Short circuit to machine controller	Yes
E04	Forward switch / F-N-R lever	Broken wire	Yes
E05	Reverse switch / F-N-R lever	Short circuit to machine controller	Yes
E06	Reverse switch / F-N-R lever	Broken wire	Yes
E11	Speed sensor	Broken wire	Yes(*)
E15(Lo)	Rolling surface temperature sensor (OPT)	Broken wire or low temperature	No
E21	Vibration selector switch	Broken wire / Short circuit to machine controller	No
E22	IPF selector switch	Broken wire / Short circuit to machine controller	No
E31	Current control / Propel pump solenoid for forward	Current outside the nominal range	Yes
E32	Current control / Propel pump solenoid for reverse	Current outside the nominal range	Yes
E33	Current control / Vibration pump solenoid for left	Current outside the nominal range	No
E34	Current control / Vibration pump solenoid for right	Current outside the nominal range	No
E41	CAN BUS / ECU	Signal defect to machine controller	Yes(*)
E42	Traveling controller	Signal defect to machine controller	Yes
E43	Exact meter	Signal defect to exact meter	Yes
E44	Working controller	Signal defect to machine controller	Yes
E45	Working controller	Parameter error	Yes
E61,E65	Potential meter	Potential error at the Neutral position	Yes
E62,E66	Potential meter	Potential error at the Forward or Reverse position	Yes
E63,E67	Potential meter	Potential error at the motionless F-N-R lever	Yes
E64,E68	Potential meter	Potential error at the motion F-N-R lever	Yes

### IMPORTANT

**When the machine controller malfunctions or fails, contact your SAKAI Dealer immediately for appropriate inspection, maintenance, or repair.**

**NOTE:** Refer to “Emergency traveling” on page 50 when it is necessary to move the machine urgently.

\* Only AUTO SPEED mode, see 2. 3. 6 AUTO SPEED.

## 2. OPERATION

### 2.8 Precautions for Work

#### 2.8.1 Compaction operation

##### ■ Do not operate the vibrator on a hard surface

- Do not work the vibrator on a hard surface such as concrete pavement, as this can cause the machine to jump and give abnormal shock load. Damage to shock isolators will result.

##### ■ Change the direction of travel gently

- When changing the direction of travel during asphalt mix compaction, slowly shift the F-N-R lever.

##### ■ Drive at a speed appropriate for the road surface conditions

- Drive slowly on uneven surfaces.

#### 2.8.2 When going downhill

##### ■ Use the F-N-R lever

- Run slowly going downhill. Do not use excessive speed. Avoid changing speed if possible when going downhill. Start slowly and end slowly on steep downgrades.

##### ■ Use the engine brake

- Go downhill by applying the engine brake along with the F-N-R lever operation.

#### 2.8.3 On a slope

##### ■ Working on a sidehill

- Work in an uphill / downhill direction, and avoid working on sidehill with the machine inclining sideways.

### 2.9 Applicable Jobs

The machines do a variety of jobs as listed below:

#### Work

- Asphalt road paving
- Dust removal treatment for road
- Road improvement
- Embankment construction
- Dam construction
- Construction of forestry and farm roads
- Foundation building
- Construction of sidewalk, shoulder and gutter foundation

**Material to be compacted**

- Asphalt pavement
- Crusher run
- Cement concrete
- Sands
- Soils
- Slag
- Soft rock
- Roller compacted concrete

**Layers to be compacted**

- Surface course, Binder course
- Base course
- Subgrade
- Embankment
- Shoulder
- Sidewalk

**2.10 After Operation**

Check for the coolant temperature, engine oil pressure and fuel level.

Follow the procedures below to prevent the machine from falling into an unworkable condition the following morning caused by muds and other extraneous matter on the drum, or frozen drums:

- 1) Remove soil and water from the machine. Muds can get into the seals together with water drops on the hydraulic cylinder piston rod. Damaged seals will result.
- 2) Park the machine on a hard and dry surface. If such a place is not available, cover the ground with hard plates.
- 3) Low temperature will cause a significant reduction of battery efficiency. Cover batteries or take them off the machine and store in a warm place for the following day's operation. There is a danger of battery fluid leaking when removing the battery from the machine, so take care not to tilt the battery when doing so.
- 4) To prevent freezing, drain water from the spray system. (See water spray system on page 59)

**IMPORTANT**

**Insufficient draining of water can cause damage to the machine.**

## 2. OPERATION

### 2.11 Loading and Unloading

#### ⚠ WARNING

- Use sturdy ramps with proper width, length and thickness which allow safe loading and unloading.
- If the ramps deflect considerably under load, apply wooden blocks to reinforce them.
- Loading should be conducted on a level and hard ground. Leave a sufficient distance between the machine and the shoulder.
- To prevent slippage on the ramps, keep the drums free from mud, oils, etc. The ramps must also be free of grease, oil and ice.
- Do not steer the machine on the ramps. If the machine is facing in the wrong direction, allow it to dismount from the ramps and correct the direction.

For loading and unloading, use ramps or a proper loading stand.

#### 2.11.1 Use of a trailer equipped with a winch

#### ⚠ WARNING

Placing the unloader valve in UNLOAD position disrupts the power for traction. Do not enter the areas ahead of and behind the machine. It is very dangerous.

- 1) Engage the trailer brake and chock its wheels. Fix the ramps so that the machine and trailer are completely aligned.
  - ☆ The angle between the ramps and ground must be less than 12 degrees.
  - ☆ Leave a proper space between the ramps according to the width of the roller drum.
- 2) Decide the correct direction of run and make the machine run forward to the ramps.
- 3) Draw the wire rope from the trailer winch and put its hook on the hooking point ① or ② (One each on right and left) of the roller.
- 4) Place the unloader valve located at the engine room to the UNLOAD position. (See “Unloader valve” on page 38)

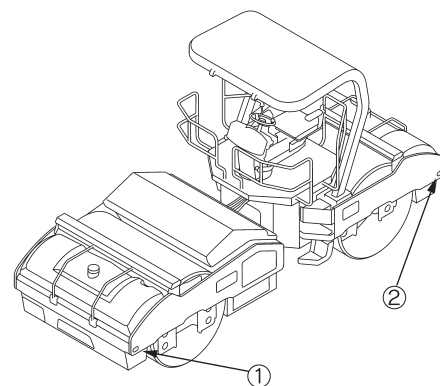
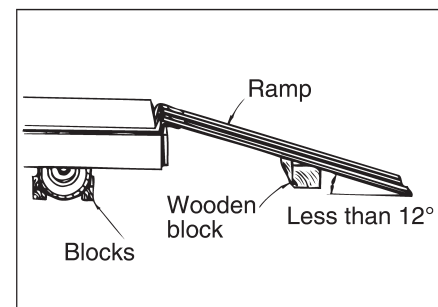

- 5) With the engine running at idle, perform loading by means of the trailer winch.
- 6) When the loading is completed, set the unloader valve back in the ONLOAD position.
- 7) Locate the machine correctly on the trailer.

### 2.11.2 Self-propelling

- 1) Engage the trailer brake and chock its wheels. Fix the ramps so that the machine and trailer are completely aligned.

☆ The angle between the ramps and ground must be less than 12 degrees.

☆ Leave a proper space between the ramps according to the width of the roller drum.

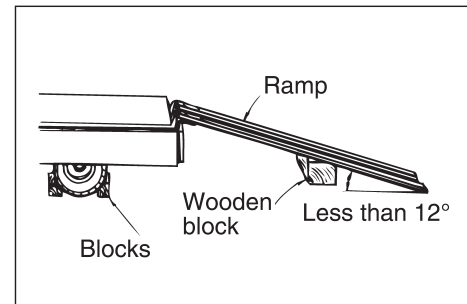

- 2) Decide the correct direction of run and conduct loading or unloading at low speed.

For loading, run forward at low speed.

For unloading, run backward at low speed.

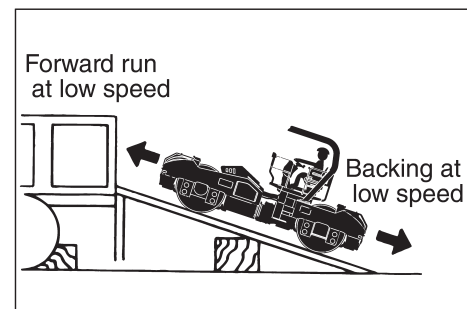

- 3) Locate the machine correctly on the trailer.

### 2.12 After Loading the Machine

When the machine has been located properly on the trailer, tie it down as follows:

- 1) Press the parking switch button to apply the parking brake. Place wooden blocks under the drums to prevent movement.
- 2) Fix the machine with ropes tied at the front and rear towing hook holes. Particularly, pay attention to sidewise skidding.

## 2. OPERATION

### 2.13 Transportation

#### **⚠ WARNING**

**To decide the transporting route, check the width of the road, height and weight (including the roller) of the trailer. Obey relevant regulations.**

For transportation, obey traffic regulations.

### 2.14 Operation in Cold Weather

In cold weather, take the following measures to prevent troubles such as starting difficulty and coolant freeze-up.

#### 2.14.1 Fuel oil and grease

Use fuel and oil with low viscosity. See “ Rating ” on page 98 and 99.

#### 2.14.2 Coolant

#### **⚠ WARNING**

**Do not bring an open flame to the antifreeze or do not smoke when handling it. It is inflammable.**

#### **⚠ CAUTION**

**Use ethylene glycol-base antifreeze.**

For the cooling water, mix the antifreeze in water.  
Use softened water as the water to be mixed.  
Please refer to the following table for the mixing ratio.

Ambient temperature	Always
Amount of anti-freeze	10.5L (2.8gal)
Amount of water	10.5L (2.8gal)
Ratio	50%

Our machines are filled with a long-life coolant.  
The life of the antifreeze is for two years.  
Use non-amine type long-life coolant when changing coolant.



**⚠ CAUTION**

**Failure to follow this procedure can result in severe engine damage.**

**Fill :** 1) Fill coolant at 3 gallons per minute (12 liters per minute) until coolant reaches the bottom of the fill neck. Wait for 1 minute, then top up coolant to the bottom of the fill neck if needed.

2) Start engine and run at “mid” speed for 1 minute or until engine warning lamp comes on.

3) Turn off engine and top up coolant to bottom of fill neck if needed.

4) Replace coolant cap.

**⚠ WARNING**

- Do not remove the radiator cap while the coolant is hot.
- Hot water may be spouted out that can cause scald. Relieve pressure by slowly turning the cap after the water temperature is dropped, then remove the cap.



## 2. OPERATION

### 2.14.3 Battery

#### **⚠ WARNING**

- The battery contains diluted sulfuric acid, which will dissolve clothes and skin. Should you get battery fluid on your clothes or skin, wash it off immediately with copious quantities of clean water.
- If you get it in your eyes, rinse them straight away with clean water and immediately seek the help of a doctor.
- If you accidentally ingest it, drink copious quantities of water and immediately seek the help of a doctor.
- Always wear safety glasses when handling the battery.
- The battery generates hydrogen gas, so there is a danger of explosions. Avoid recharging the battery, keep cigarettes and flames away, etc., in poorly ventilated places when there is a danger of generating sparks.
- The inspection and handling of batteries should be carried out with the engine turned off and the starter switch in the "OFF" position.
- Be careful not to accidentally connect the two battery terminals with tools or other metallic objects.
- Tangled terminals may generate sparks due to improper connections, resulting in the danger of explosions. Make sure terminals are connected firmly.
- The battery is for starting the engine and operating electrical equipment on the machine. Do not use it for any other purpose.

When the temperature decreases, the battery capacity will lower, possibly freezing the electrolyte.

The battery should be maintained in a good state at all times, with care taken to keep it warm in preparation for use the next morning.

#### **⚠ CAUTION**

**The power-supply voltage of this machine is 12V.**

At low temperature, batteries are less efficient. The level of charge is lowered and batteries will tend to freeze. Maintain batteries fully charged wherever practicable, and give attention to heat insulation at night for the next day's operation.

For the level of charge, check the specific gravity of electrolyte and use the following table of conversion.

Temperature Level of charge (%)	20°C (68°F)	0°C (32°F)	-10°C (14°F)	-20°C (-4°F)
100		1.29	1.30	1.31
90	1.26	1.27	1.28	1.29
80	1.24	1.25	1.26	1.27
75	1.23	1.24	1.25	1.26

### 2.15 When the Cold Season is Over

When winter is over and the warm season has come, proceed as follows:

- 1) Change oil and fuel with those for use in warm season referring to “Rating” on page 98.
- 2) If AF-PT antifreeze is in use, drain the coolant completely, wash clean inside the cooling system, and then fill with clean water. (city water)

### 2.16 For a Long Storage Period

For leaving the machine unused for longer than one month, proceed as follows:

- 1) Store the machine in a closed area after cleaning.
- 2) Conduct oiling, greasing and changing of oil.
- 3) Grease lubricate the exposed portion of hydraulic cylinder piston rods.
- 4) Cover the battery after disconnecting the negative cable or take off the battery from the machine and store in a safe place.
- 5) If the temperature is expected to go down below 0°C, add antifreeze to the coolant.
- 6) Completely drain the spray system.
- 7) Place the F-N-R lever in the neutral position (N), and apply the parking brake.
- 8) Chock the machine.
- 9) Remove the starter switch key.

### 2.17 During the Storage Period

**⚠ WARNING**

**If necessary to operate the machine for anti - corrosive purpose in closed area, ensure good ventilation keeping windows and doors open to prevent gas poisoning.**

- During storage, operate the machine at least once a month to prevent the oil films on the lubricated parts from deteriorating and to charge the batteries.
- Disengage the brake at least once a month to prevent the brake lining from sticking to the brake drum, and travel the machine forward and backward. Then, engage brake again.

## 2. OPERATION

### 2.18 When the Battery has Discharged

#### ⚠ WARNING

- To check and handle the batteries, keep the engine stopped with the starter switch in the "O" position.
- The batteries give off explosive gases. Do not smoke close to the batteries. Keep flames and sparks away from the batteries.
- The electrolyte is very corrosive and will harm your clothing or skin. If the electrolyte has come into contact with your clothing or skin, flush with sufficient amount of water. In case the electrolyte has gotten into your eyes, flush with water and get medical help.
- To disconnect the battery cables, start with the negative terminal (earth). When connecting, start with the positive terminal. Do not allow a metallic item to bridge between the positive terminal and machine body. This can generate sparks, causing an explosion.
- Loose battery terminals can cause sparks. An explosion will result. When connecting the terminals, make certain that they are tight.

Disconnect with negative cable first

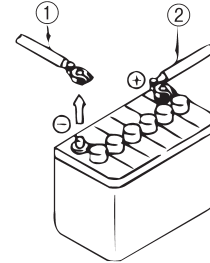

Connect with positive cable first

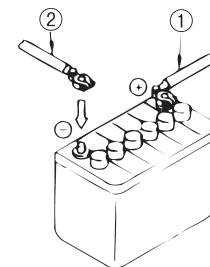

#### ⚠ CAUTION

The power-supply voltage of this machine is 12V.

#### 2.18.1 Connection and disconnection of booster cables

When jump-starting the engine, connect the booster cables as follows:

##### ■ Connection of booster cables

- 1) Connect one end of the positive booster cable (A) to the positive  $\oplus$  terminal of the dead battery on the machine.
- 2) Connect the other end of the positive booster cable to the positive  $\oplus$  terminal of the live power supply.
- 3) Connect the negative booster cable (B) to the negative  $\ominus$  terminal of the live power supply.
- 4) Connect the other end of the negative booster cable to a good earth ground on the engine block of the machine.

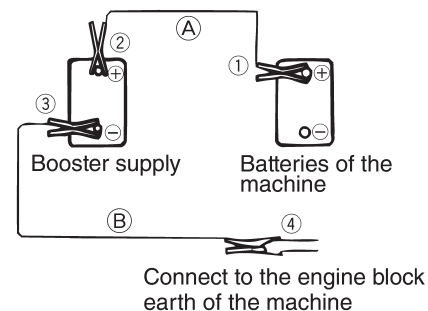

Connect to the engine block earth of the machine

■ **Disconnection of booster cables**

- 1) Disconnect the negative booster cable (B) from the engine block earth.
- 2) Disconnect the negative booster cable (B) from the booster supply.
- 3) Disconnect the positive booster cable (A) from the booster supply.
- 4) Disconnect the positive booster cable (A) from the machine.

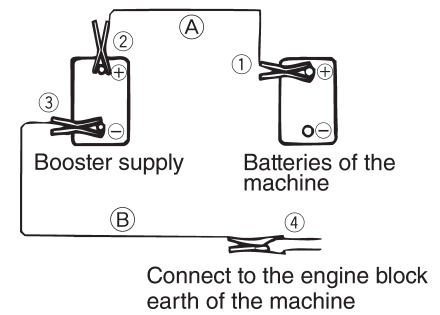

⚠ **WARNING**

- Do not allow the positive ⊕ terminal to make contact with the negative ⊖ terminal when connecting the booster cables.
- Wear safety goggles when jump-starting the engine.
- Do not allow the machine to make careless contact with the booster supply.
- Do not make wrong connections. Connect the negative ⊖ cable to the engine block earth far away from the battery, as sparks may occur when connecting.

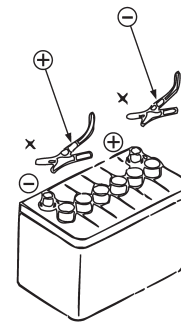

⚠ **CAUTION**

- Use booster cables and end clips of proper size suited to the battery capacity.
- Use the batteries of the equal capacity for the machine and booster supply.
- Check booster cables and end clips for signs of damage and corrosion.
- Connect the clips positively.

### 3. PERIODIC MAINTENANCE

## 3 PERIODIC MAINTENANCE

### 3.1 Precautions

Whether or not the inspection service and lubrication are performed at the correct regular intervals exerts significant influence on the occurrence of problems and service life of the machine. In this manual, typical intervals for inspection and service are given. However, flexibility should be exercised as to interval or type of services to enable your machine to always operate in the best condition.

#### IMPORTANT

- **After maintenance and inspection, record the result of inspection. Remember that replacement of filters and elements, replenishment and change of oil and grease, and cleaning of the radiator fins is important.**
- **The disposal of waste oil and coolant, and used filters, elements, etc., should be handled by specialized disposal companies.**

#### General precautions

- 1) Always use Sakai genuine parts for replacement.
- 2) Use lubricants recommended by Sakai. Avoid mixing different brand lubricants.
- 3) For hydraulic oil replenishment, changing, level checking, filter cleaning or replacement, oiling and greasing, use extreme care to prevent dust from entering.
- 4) For checking oil level or changing oil, park the machine on a level and hard surface.
- 5) Change oil while its temperature remains high after operation.
- 6) For a long-term storage, fill the fuel tank, lubricate necessary points and run the machine for more than 20 minutes once a month.
- 7) In freezing weather, add antifreeze to the coolant according to the ambient temperature.
- 8) For the hydraulic pump and motor, have them serviced at authorized service shops.
- 9) Turn the starter switch OFF when performing services such as repairing broken wires, short circuits and tightening loose terminals.

#### Periodic replacement of essential maintenance parts

In order secure safety for work and travel, conduct inspection and services.

Further, for enhanced safety, following parts and components should be replaced periodically. These parts are prone to material deterioration due to aging or physical change due to friction, while it is difficult to determine their useful limit by regular inspection, which makes it necessary to replace with new ones after certain period of service to maintain their perfect function.

If any abnormality is detected such as crack, deformation or oil leakage, go ahead and replace them even if it is within scheduled replacement time.

### 3. PERIODIC MAINTENANCE

System or Mechanism	Part name	Periodical replacement maintenance part	Replacement period	Remarks
1 Brake system	Master cylinder	Seals (rubber parts)	2 years	
	Wheel cylinder	Seals (rubber parts)	2 years	
	Brake piping parts	Brake hose	2 years	
		Air hose	2 years	
Operating parts	Cable	4 years		
2 Steering system	Orbitrol	Seals (rubber parts)	2 years	
	Hydraulic piping parts	Hydraulic hose	2 years	
	Steering cylinder	Seals (rubber parts)	2 years	
	Hydraulic pump	Seals (rubber parts)	4 years	
3 Power transmission system (inclusive of axle)	Axle	Seals (rubber parts)	4 years	
	Travel pump	Seals (rubber parts)	4 years	
	Travel motor	Seals (rubber parts)	4 years	
	Hydraulic piping parts	Hydraulic hose	4 years	
	Isolation rubber	Isolation rubber itself	4 years	
4 Fuel system	Piping parts	Fuel hose	2 years	
5 Engine related	Engine mounting parts	Isolation rubber	4 years	
	Seals (rubber parts)	Packing and others	4 years	
	Drive parts	V-belt	2 years	or 500 hours
	Piping parts	Engine drain hose	4 years	
6 Cooling system	Piping parts	Radiator hose	2 years	
		Radiator drain hose	4 years	
7 Control related parts	Cable	Cable	4 years	
8 Intake system	Piping parts	Intake hose	2 years	
		CAC hose	2 years	
9 Hydraulic system	Hydraulic piping parts	Hydraulic hose	4 years	

#### **⚠ CAUTION**

- **With a new machine, change the engine oil and change the engine oil filter element after 50 hours of operation for the first time only. (Refer to page 83)**
- **When trouble occurs in the location indicated by the indicator lamp on the dashboard display, sensor will work and corresponding lamp comes on. If this occurs, conduct necessary service regardless of the periodical service interval recommendation.**
  - 1) **The hydraulic filter (line filter) warning lamp ⇨ Replace elements**
- **Check the electric wiring at a regular interval not exceeding one month, when there is abnormality, replace it.**

**If there are some trouble on the electric wiring, replace them with new one.**

  - 1) **Damage to the wire harness and loose clamps**
  - 2) **Loose sockets**
  - 3) **Function of electrical systems**
- **For the parts other than listed above, if there are some trouble on the parts at periodical inspection or daily check, replace them as soon as possible.**

### 3. PERIODIC MAINTENANCE

#### 3.1.1 Lifting the machine on a hoist

##### **⚠ WARNING**

- Get qualified personnel to lift and lower the machine on a hoist.
- Use sturdy wire ropes.
- Lock articulation by means of lock bar located at the center of machine.

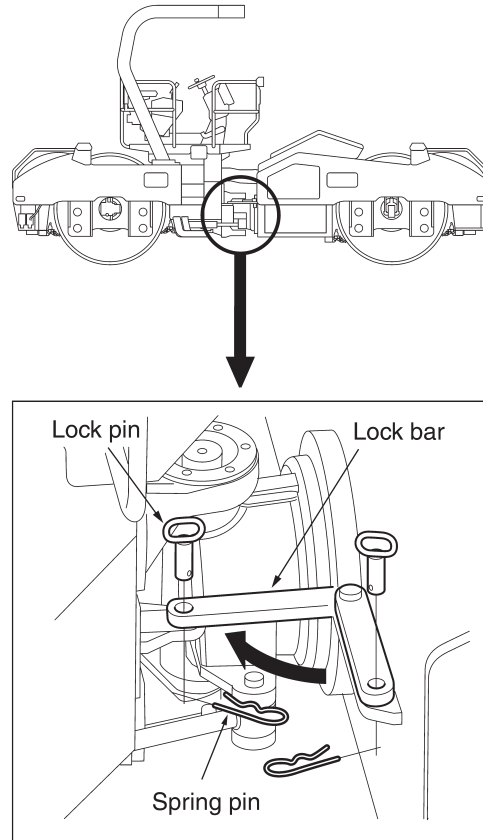

##### **⚠ CAUTION**

**Remove ROPS before starting lifting work.**

- 1) Put wire ropes securely on the hook and lifting points as shown.

**NOTE:** Use appropriate wire rope size.

- 2) If wire ropes make contact with other parts of the machine, put pieces of cloth or wooden blocks at the contact points. Carefully perform lifting.
- 3) When lifting, keep the machine properly balanced.

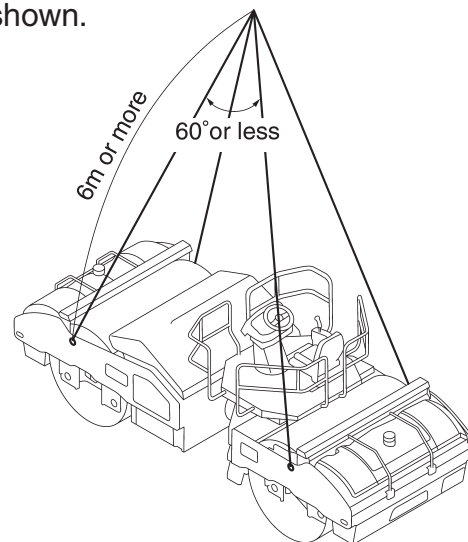

##### **⚠ WARNING**

**Make sure wire ropes are not damaged.**



### 3.2 Walk-around Checking

For efficient operation, daily, before-operation checking is very important. Before starting, perform walk-around checking for loose bolts, nuts and signs of leakage in addition to items as shown below:

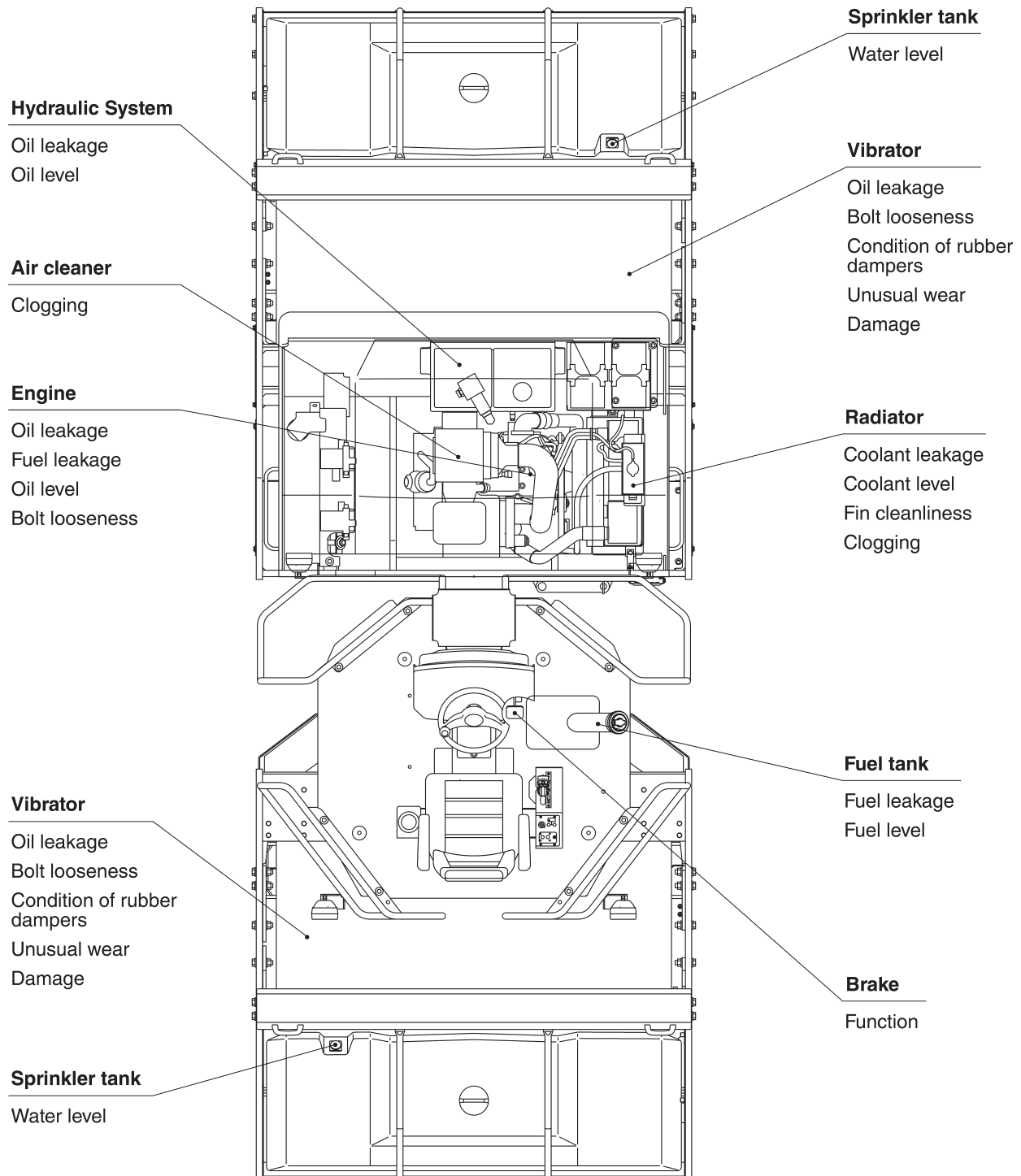

3. PERIODIC MAINTENANCE

3.3 Periodic Maintenance Points

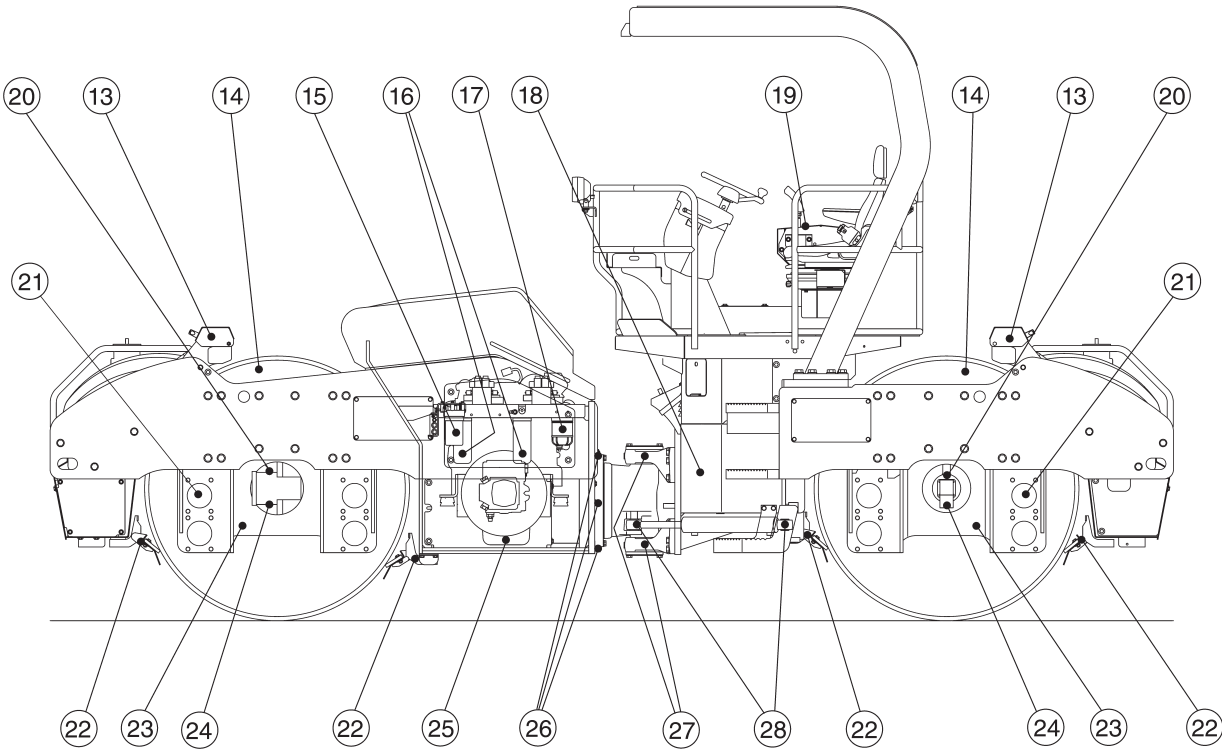
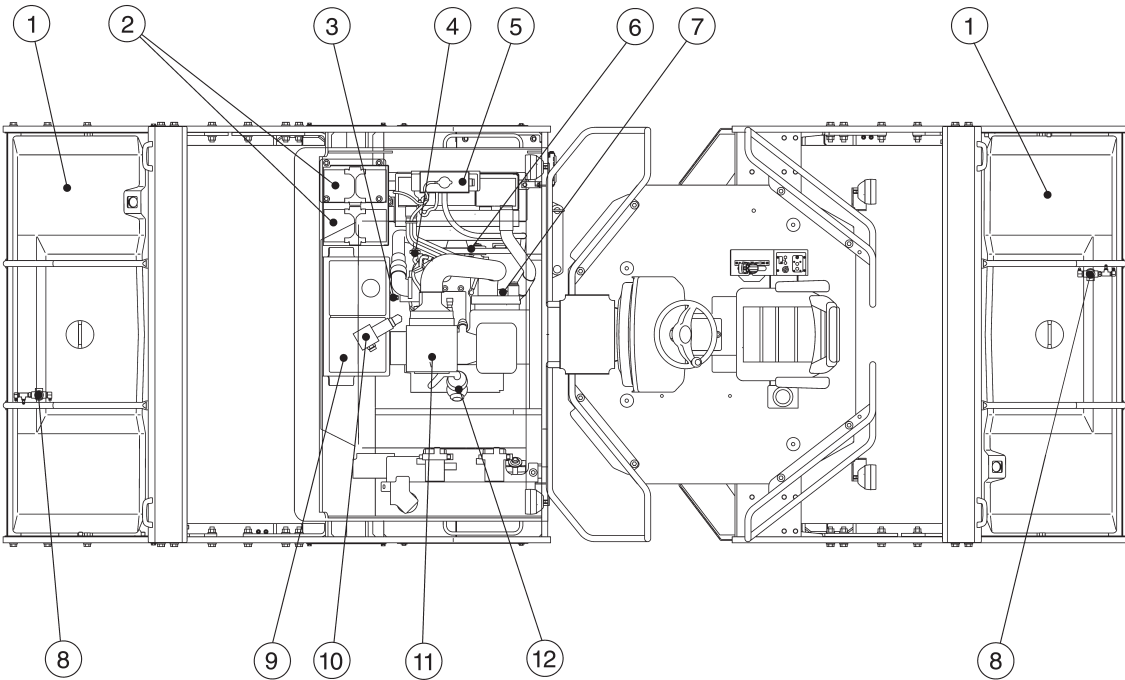

### 3. PERIODIC MAINTENANCE

Interval	No	Item	Service	Lubricant	Q'fy
Every 10 service hours or daily	④	Engine oil level gauge	Check oil level	Engine oil	1
	⑤	Auxiliary tank	Check coolant level	Coolant	1
	⑥	Fan belt	Check tension and unusual wear		1
	⑪	Air cleaner	Check indicator		1
	⑰	Fuel pre-filter	Check drain water and dirt		1
Every 50 service hours	②	Batteries	Check looseness of terminal and appearance	Battery fluid	2
	③	Hydraulic oil level gauge	Check oil level	Hydraulic oil	1
	⑧	Sprinkler filter	Clean filter element		2
Every 250 service hours	⑦	Engine oil filter	Change filter element		1
	⑬	Sprinkler pipe	Clean inside pipe		4
	⑭	Vibrator	Check oil level	Gear oil	2
	⑳	Rubber dampers	Check for cracks		24
	㉕	Engine oil pan	Change engine oil	Engine oil	1
Every 500 service hours	⑮	Fuel filter	Change filter element		1
	⑯	Hydraulic oil line filter	Change filter element		2
	⑰	Fuel pre-filter	Change filter element		1
	⑲	Control links	Check looseness and adjust		-
	㉖	Tilt pin bearing	Grease 4 fittings	Grease	4
	㉗	Center pin bearing	Grease 2 fittings	Grease	2
	㉘	Cylinder head and anchor pins	Grease 4 fittings	Grease	4
Every 1000 service hours	⑨	Hydraulic oil tank	Change hydraulic oil	Hydraulic oil	1
	⑩	Hydraulic oil suction filter	Clean filter element		1
	㉑	Gear case (Wheel motor)	Change gear oil	Gear oil	2
	㉒	Vibrator	Change gear oil	Gear oil	2
	㉔	Brake	Check brake disk thickness		-
As needed	①	Water tank	Clean inside tank		2
	⑪	Air cleaner	Change element		1
	⑫	Breather	Clean filter element		1
	⑱	Fuel tank	Drain water and dirt		1
	㉚	Scrapers	Adjust and clean		4

#### IMPORTANT

- Ensure that the 10 hour maintenance is carried out and that there are no loose bolts, nuts or oil leaks before starting.
- No.4, 19 : Carry out servicing when the monitor lamp lights up, besides following the instructions shown above.

### 3. PERIODIC MAINTENANCE

#### 3.4 Maintenance Procedure

➔ For servicing the engine, see the separate engine manual.

##### (1) Every 10 service hours or daily

###### ④ Engine oil level gauge

➔ See the separate engine manual.

Check the amount of engine oil after the engine is completely stopped. Pull out the oil level gauge and wipe off oils by waste clothes. Re-insert the oil level gauge into the full length of the oil dip pipe and pull it out. Check that the oil level is between “MAX” and “MIN”. In case of shortage, feed oils through the engine oil fill port.

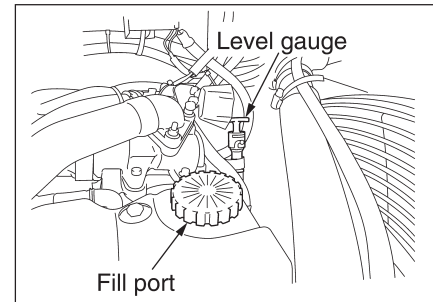

**NOTE:** When checking the amount of oils after running the engine, please check at least 15 minutes after the engine is stopped. If the machine is inclined, please move it to the flat ground before start checking it.

###### ⚠ WARNING

It may cause scald immediately after that the engine is stopped because the temperature of the parts and the oils may be raised. Please start checking it by waiting until the temperature is dropped.

###### ⑤ Auxiliary tank

Check to see coolant level in the sight glass, if coolant can not be seen, replenish with the tank cap removed. Use soft water only.

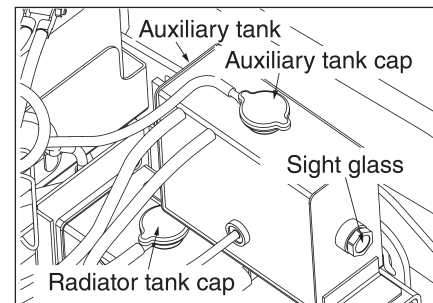

###### ⚠ CAUTION

Failure to follow this procedure can result in sever engine damage.

- Fill :
- 1) Fill coolant at 3 gallons per minute (12 liters per minute) until coolant reaches the bottom of the fill neck. Wait for 1 minute, then top up coolant to the bottom of the fill neck if needed.
  - 2) Start engine and run at “mid” speed for 1 minute or until engine warning lamp comes on.
  - 3) Turn off engine and top up coolant to bottom of fill neck if needed.
  - 4) Replace coolant cap.

### 3. PERIODIC MAINTENANCE

#### **⚠ WARNING**

- Do not remove the radiator cap while the coolant is hot.
- Hot water may be spouted out that can cause scald.  
Relieve pressure by slowly turning the cap after the water temperature is dropped, then remove the cap.



**NOTE:** Replace long-life coolant every two years. Replace the other types every year.

#### **⑥ Fan belt**

Check the fan belt for wear and damage. Replace as necessary.

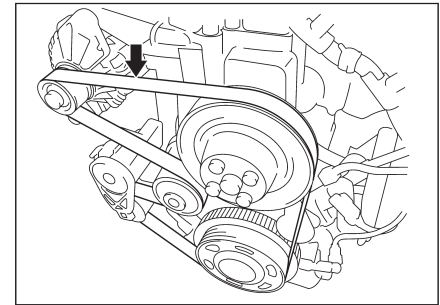

#### **IMPORTANT**

Please see the separate engine manual for engine for more details on fan belts.

#### **⚠ WARNING**

Make certain that the engine is completely stopped to avoid any risks when checking looseness, tensions and damages for the fan belts.  
Also make certain that the key is removed from the key cylinder.

#### **⑪ Air Cleaner**

When the red float of the dust indicator reaches the service level (a mark on the indicator), clean the element (See page 94).

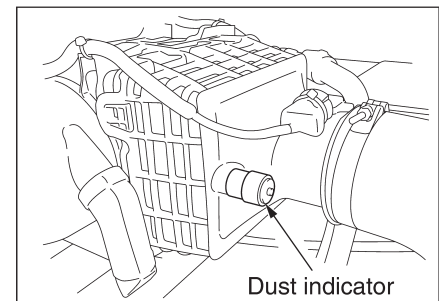

### 3. PERIODIC MAINTENANCE

#### ⑰ Fuel pre-filter

Please check if it is filled with water at the lower part of the filter. If it is filled with water, remove the plug at the bottom to drain water.

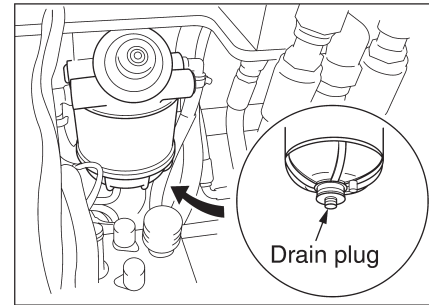

#### (2) Every 50 service hours

#### ② Batteries

- 1) When the terminal is loose, tighten it up and thinly apply vaseline or grease for rust prevention.
- 2) Check that there is no abnormality on the surface.
- 3) Be sure to tighten the battery holder if it is loose.

#### ⚠ CAUTION

The power-supply voltage of this machine is 12V.

#### ③ Hydraulic oil level gauge

Check the oil level with the sight glass on the side of tank. The level is proper if it is between H and L marks. Of necessary, add the hydraulic oil from the fill port.

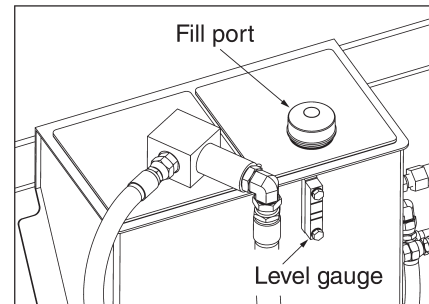

#### ⚠ WARNING

Be sure to use hydraulic oil recommended by SAKAI.

#### ⑧ Sprinkler filter

Take off the filter bowl by turning counter-clockwise as viewed from the bottom. Clean the element.

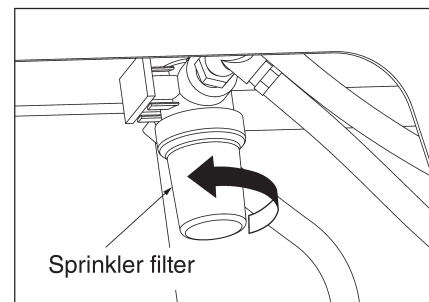

### 3. PERIODIC MAINTENANCE

#### (3) Every 250 service hours

⑦ Engine oil filter

②⑤ Engine oil pan

➔ See the separate engine manual.

- 1) Remove the cover. Loosen the drain bolt that remove the drain unit.
- 2) After completion of operation and while the oil is warm, drain the oil with the drain plug removed.

#### ⚠ WARNING

When draining a hot oil, use care not to get burned.

- 3) Put the shield tape on it, refit the drain plug and fill the crankcase with the engine oil from the fill port.
- 4) Change the engine oil filter element.

**NOTE:** For a new machine, change oil at 50 operating hours for the initial time only.

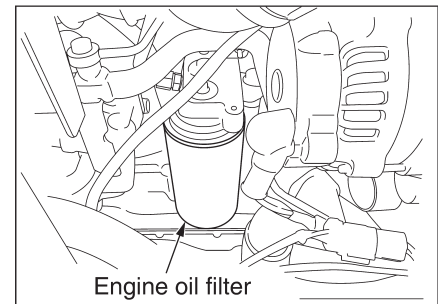
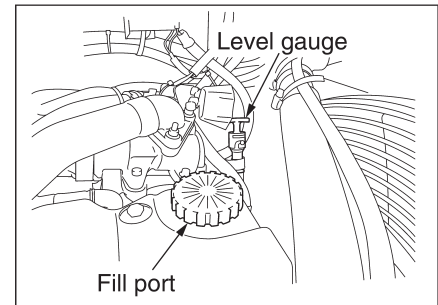
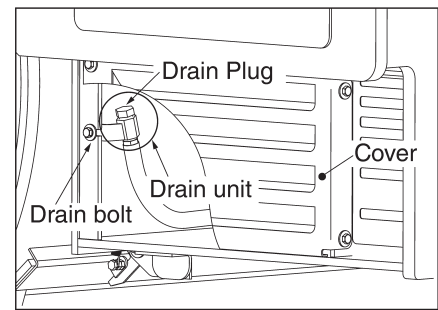

⑬ Sprinkler pipe

- 1) Spray pipe  
Remove the cap from both ends of each spray pipe.  
Operate the spray pump to wash out dust from inside the pipe.
- 2) Nozzle
  - Remove the nozzles from the spray pipe and separate the filter from each nozzle.
  - Clean the filters. Use a needle or the like to clean nozzle hole. Refit the filters to the nozzles.
  - Fit the nozzles to the pipes so that the water is sprayed in the form of a hand fan in parallel with the pipe.

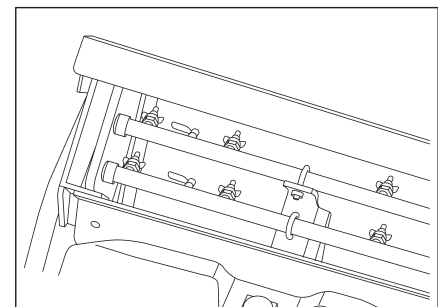

### 3. PERIODIC MAINTENANCE

#### ⑭ **Vibrator**

Check for the oil level and leakage.

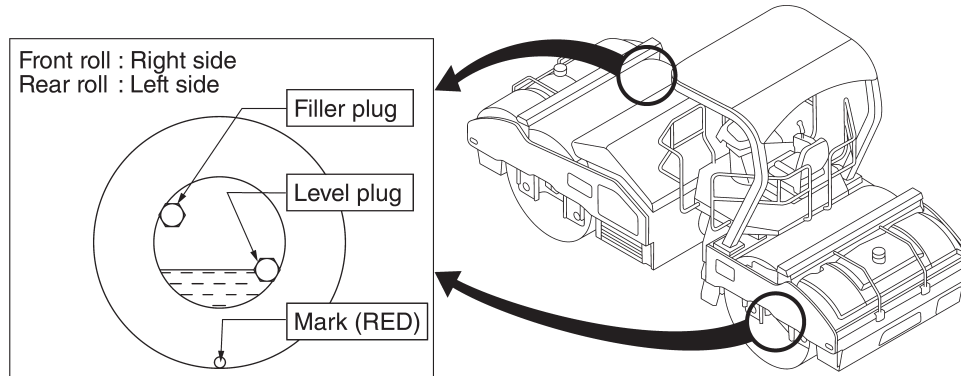

#### ⑰ **Rubber dampers**

Check the rubber blocks for cracks, and their mounting bolts for looseness.

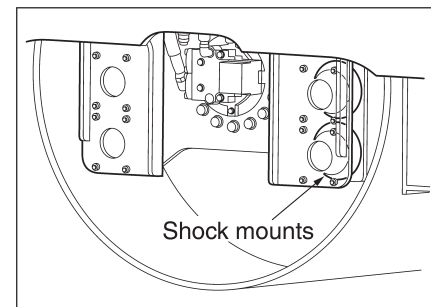



### 3. PERIODIC MAINTENANCE

#### (4) Every 500 hours

⑮ **Fuel filter**

⑰ **Fuel prefilter**

➔ See the separate engine manual.

Change the fuel filter element and the fuel pre-filter element.

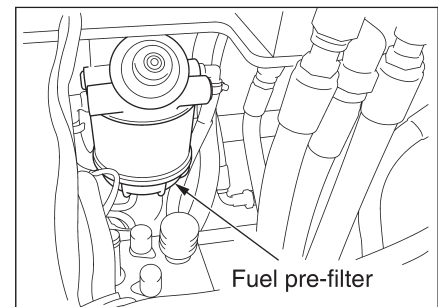
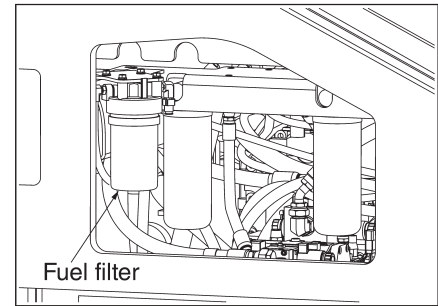

⑯ **Hydraulic oil line filter**

Change the line filter elements (2 pieces).

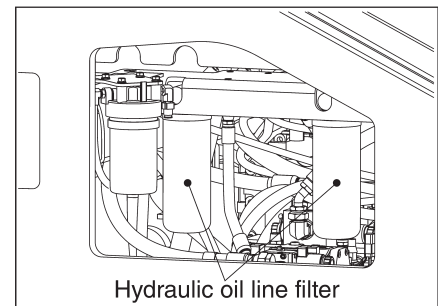

⑲ **Control links**

Remove the cover.

Check the bolts and nuts for looseness.

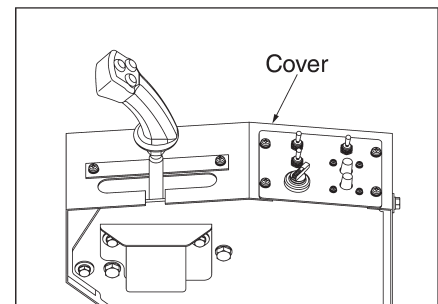

### 3. PERIODIC MAINTENANCE

#### ②6 Tilt pin bearing

#### ②7 Center pin bearing

Apply grease at 6 locations.

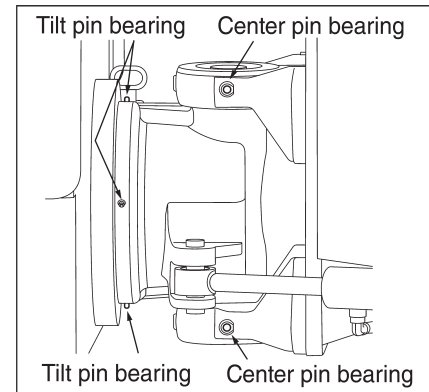

#### ②8 Cylinder head and anchor pins

Apply grease at 4 locations.

The steering cylinder is provided on both sides of the machine.

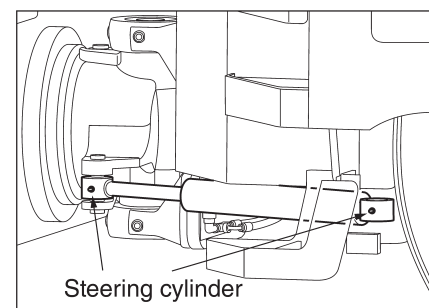

### 3. PERIODIC MAINTENANCE

#### (5) Every 1,000 service hours

##### ⑨ Hydraulic oil tank

- 1) Remove the drain plug, and drain oil while it is warm.
- 2) Clean inside of the tank, and fill fresh oil to the specified level.
- 3) Start and run the engine at idling for 2 to 5 minutes. When the hydraulic oil has become free from air bubbles, stop the engine and recheck the oil level.

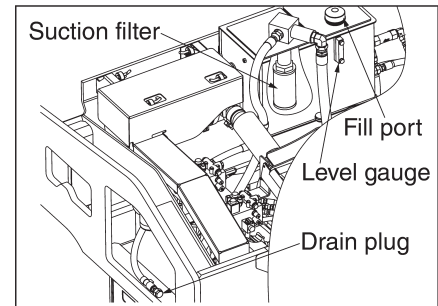

#### **⚠ WARNING**

**When draining a hot oil, use care not to get burned.**

##### ⑩ Hydraulic oil suction filter

Take off the hydraulic tank cover. Take out and clean the strainer, change the strainer if necessary.

##### ⑳ Gear case (Wheel motor)

- 1) Position it so that drain plug comes to the bottom.
- 2) While oil is warm, drain it with drain plug and level plug removed.
- 3) Rotate the roll so that drain port comes to top (or side) and level plug to side (or top). Feed oil until it overflows from the level port.
- 4) Replace the drain plug and level plug to original positions.

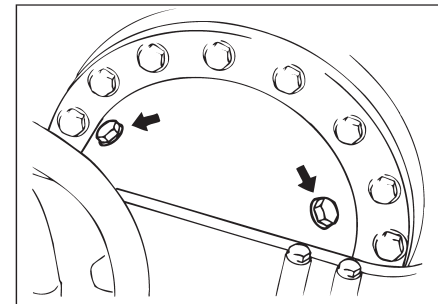

#### **⚠ WARNING**

**When draining a hot oil, use care not to get burned.**

### 3. PERIODIC MAINTENANCE

#### 23 Vibrator

- 1) Rotate the drum till the level plug comes to bottom.
- 2) Remove the fill oil plug and level plug.
- 3) Drain oil from vibrator.
- 4) Rotate the roll until the mark on its inside comes to the bottom.
- 5) Feed oil at filler port until oil flows out of level gauge hole.
- 6) Reinstall the level gauge plug as well as filler oil plug after cleaning them.

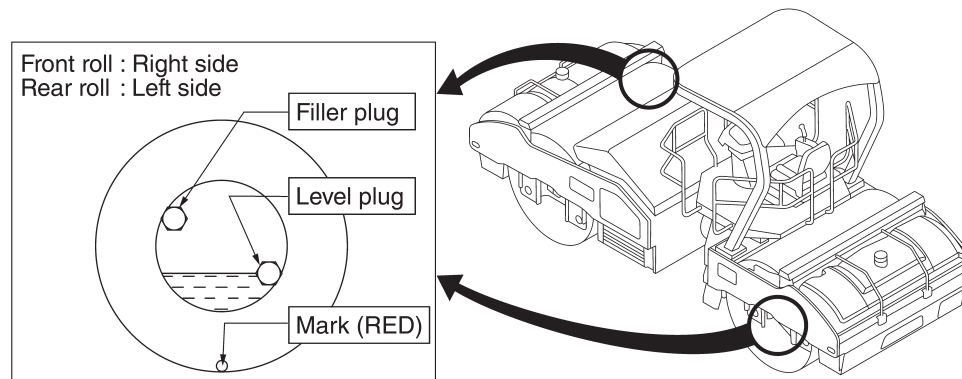

#### **⚠ WARNING**

When draining a hot oil, use care not to get burned.

#### **⚠ CAUTION**

The oil capacity of the vibrator is 22 liters. Do not fill more than 22 liters.

### 3. PERIODIC MAINTENANCE

#### 24 Brake

- Loosen hex socket bolts (6 bolts) which have been fixing end cap.  
Loosen them uniformly because the brake spring tends to push up the end cap.

Bold size	M16 x 50L
Hex socket head across flats	14

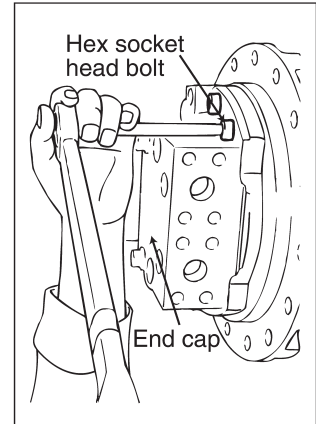

#### ⚠ CAUTION

Mating surfaces of end cap, valve plate and cylinder block having been lapped, care should be taken not to damage them.

- Remove following parts which will be exposed after removing the end cap.

Item	Quantity
Valve plate	1
Brake spring	8
Pin	2
O-Ring (large)	1
O-Ring (Small)	1

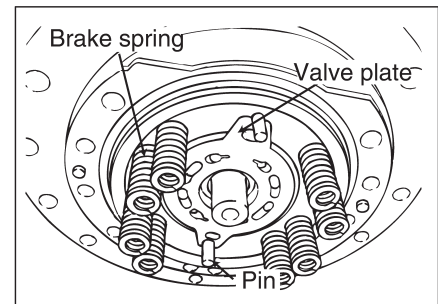

It is recommended that O-Rings are replaced with new ones.

- Blowing compressed air of 2 – 3 kgf / cm<sup>2</sup> into hole shown in sketch, brake piston will come up. (Have the opposite side hole plugged.)  
Or, with M10 x 25 – 30L bolt turned into tapped hole at 2 locations of brake piston, lift it alternately using a wrench or the like as fulcrum point.

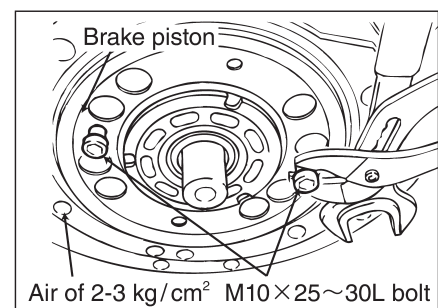
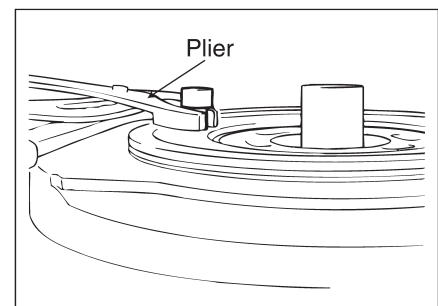

### 3. PERIODIC MAINTENANCE

- 4) Take out separate and friction plates. Using a wire with its end bent, will allow you to take them out more easily.

Item	Quantity
Separate sheet	4
Friction plate	3

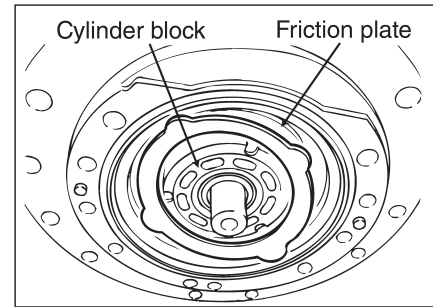

#### ⚠ CAUTION

**Do not pull out the cylinder block. Pulling it out at this stage makes it impossible to reassemble.**

- 5) Install separate plate and friction plate alternately. Be careful to install them in the correct quantity and order.

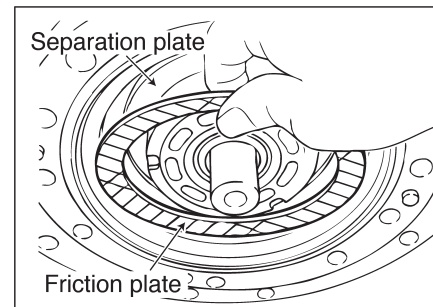
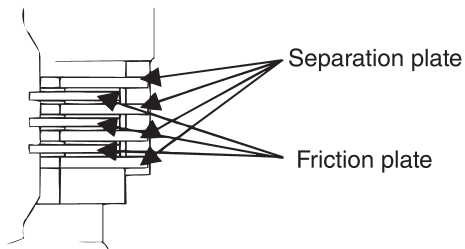

- 6) Remove brake releasing port plug (19 across flats) from end cap. Sub-assemble, with M10 bolt, the brake spring, valve plate and pin so that they are held between the end cap and brake piston (provisional assembling).

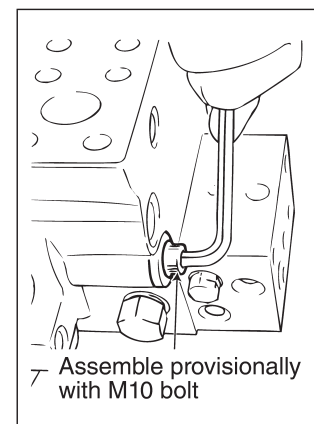
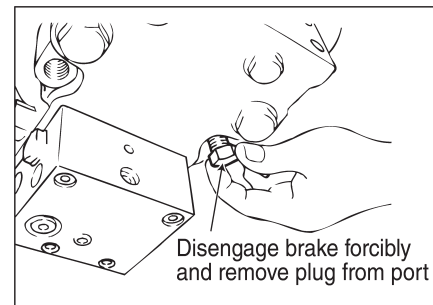
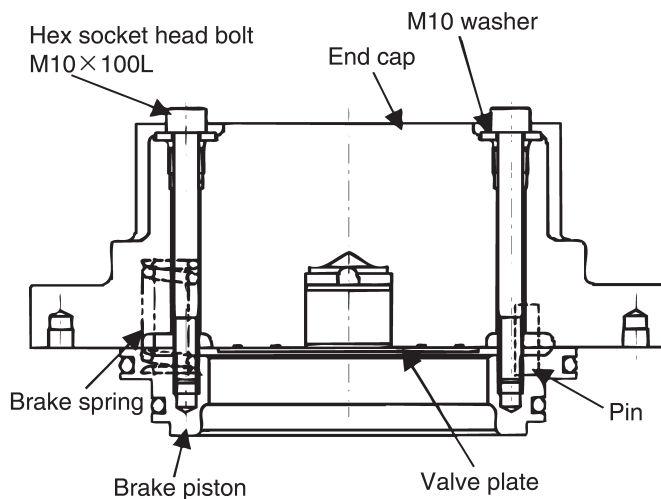

### 3. PERIODIC MAINTENANCE

7) Tighten this sub-assembled end cap to the housing with hex socket head bolt.

**⚠ CAUTION**

**Install as straightly as possible so that the shaft end does not damage journal bearing which has been press-fit to end cap.**

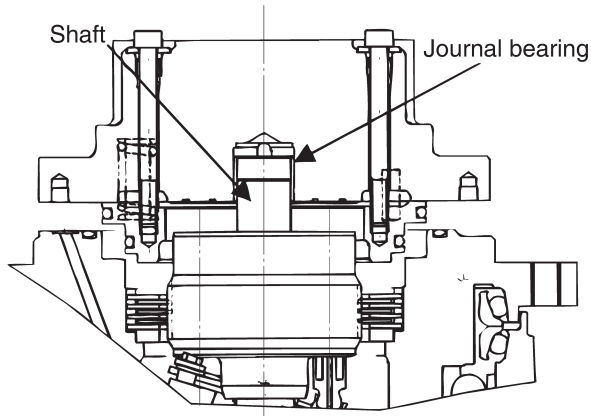

Remove M10 bolt for provisional assembly and install formal plug

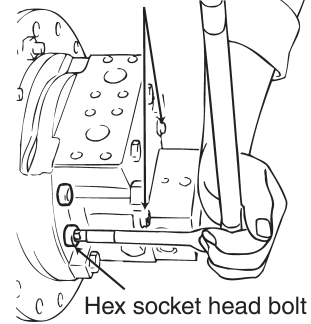

< Tightening torque for the hex socket head bolt >

Bolt size	M16 x 50L
Tightening torque	340-425 ft lb

< Tightening torque for the hex socket head bolt >

Plug size	9 / 16 – 18 UNF
Tightening torque	40 – 70 ft lb

### 3. PERIODIC MAINTENANCE

#### List of replacement parts

It is recommendable that, in addition to friction and separate plates, relevant O-Ring are replaced with new ones as well.

No.	Item	Quantity	Drawing # (DAIKIN Dwg.# (Standard JIS Nominal)
			BMV75, BM75
7	O-Ring	4 (2)	KP1B010A / 1BP10A
29	Separate plate	4	1731874
30	Friction plate	3	SP1051
33	O-Ring	1	KG1B185 / 1BG185
34	O-Ring	1	SP1092 / WG45
37	O-Ring	1	KG1B160 / 1BG160

**NOTE:** Quantity for No.7 O-ring: 4 for BMV75 and 2 for BM75.

For BMV series, as the seal for the second speed selection passage, 2 more are in use than for BM series.

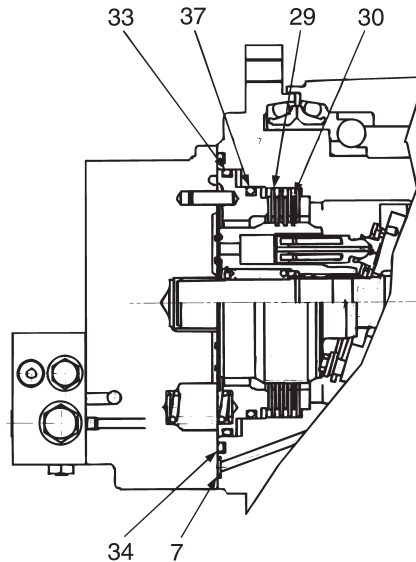

If it falls in any of the following cases, without waiting for 1,000 operating hours, replace the friction and separate plates altogether.

- 1) When the braking force becomes weaker than driving force of hydraulic motor. (Despite that the brake is being actuated, hydraulic motor rotates when HST drive is engaged)  
Checking procedure: While depressing the parking brake switch, open the throttle fully and engage the reversible travel lever. If traveling starts, replace the plates.
- 2) When total thickness of friction and separate plate falls short of the value in the chart below.



### 3. PERIODIC MAINTENANCE

Standard dimensions		
Separate plate	4 plates:	2.3 (per plate)
Friction plate	3 plates:	3.3 (per plate)
Total thickness		19.1
Standard total thickness for replacement		
		18.5

Thickness of separate and friction plates for SW880-1 and SW990-1 are the same.

→ Checking procedure: Disassemble and measure the plate thickness in every 500 hours of operation in accordance with the instruction given earlier.

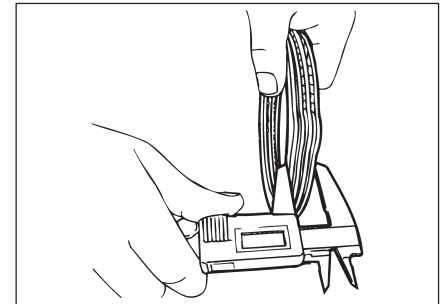

#### (6) As needed

##### ① Water tank

- 1) With the drain cap removed, remove the water and sediment from the bottom of the tank.
- 2) If sedimentation is substantial, remove the drain plug and clean the interior of the tank.
- 3) When the necessary work is complete, refit the drain cap and filler cap.

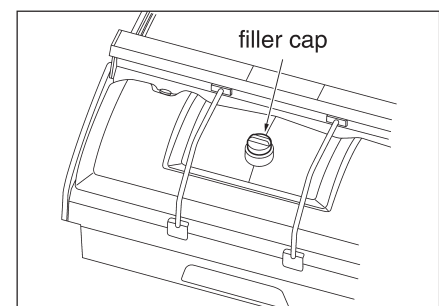
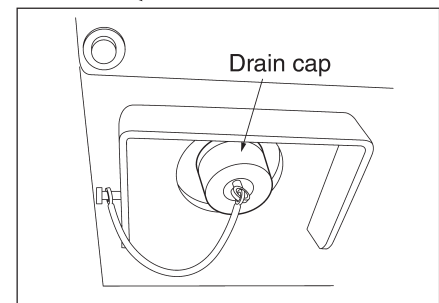
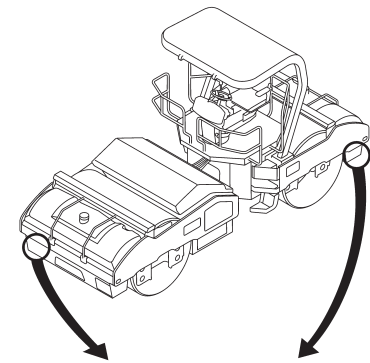

### 3. PERIODIC MAINTENANCE

#### 11 Air cleaner

When the red float of the dust indicator reaches the service level (a mark on the indicator), change the element as described below.

- 1) Release the service door clips to remove the primary element from the main filter housing.
- 2) Primary element:  
Grasp the handle in the center of the element and pull the filter element outward.  
Clean the inside of the housing with a damp rag to remove all loose dirt and dust.

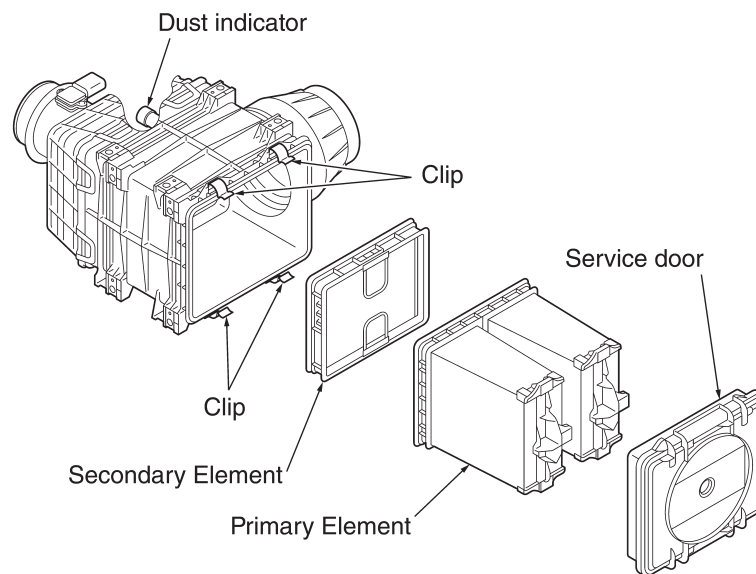

#### 3) Secondary Element

##### ⚠ CAUTION

- Take caution when removing the secondary element. Any loose debris can fall into the air intake plumbing leading directly to the engine. Clean the area around the secondary filter element and replace the secondary promptly to avoid engine contamination ingestion.
- Do not attempt to clean the filter element. Cleaning filter elements by impact or compressed air voids the warranty and can degrade or damage the filter media leading to malfunction.

**NOTE:** The secondary element should be changed every third time that the primary element is changed. If the primary element has been breached then an inspection of the secondary filter must be performed and changed if necessary.  
The secondary element is removed by pulling on the plastic ring tabs on the inside face of the filter element.

### 3. PERIODIC MAINTENANCE

#### **⚠ WARNING**

- **Stop the engine before inspection, cleaning, or maintenance, otherwise dust will enter the engine, causing the breakdown of the engine.**
- **Wear protective goggles, a dust respirator, and other protective gear before cleaning the air cleaner and outer element in order to prevent dust from entering your eyes or nose.**
- **Be sure to use our genuine element.**

4) Attach the element and service door it with a clips.

#### **⑫ Breather**

➔ **See the separate engine manual.**

Provide inspection and cleaning of the breather hoses and breather elements.

When you find any damage, make sure to replace it.

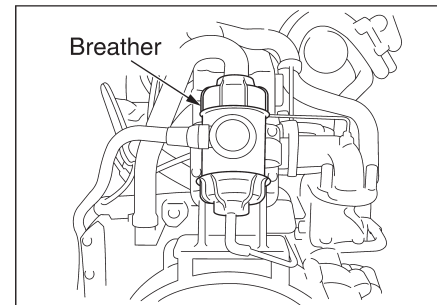

#### **⑱ Fuel tank**

- 1) With the drain plug removed, remove the water and sediment from the bottom of the tank.
- 2) If sedimentation is substantial, remove the drain plug and clean the interior of the tank.
- 3) When the necessary work and refueling are complete, tighten the filler cap positively.

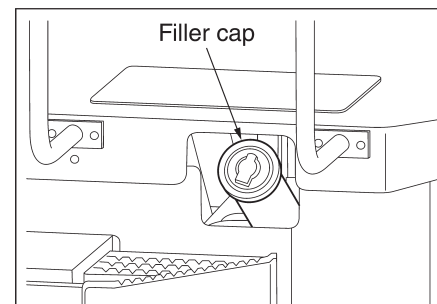
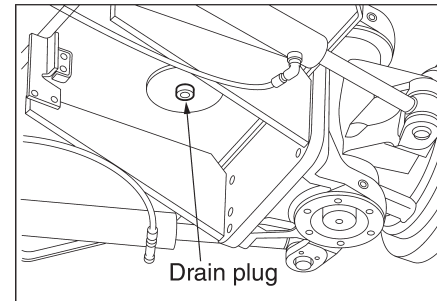

### 3. PERIODIC MAINTENANCE

#### ② Scrapers

When the blade is worn, adjust the scraper properly.

See page 40 for adjustment. If the clearance is beyond the adjustable range, change the blade.

#### **⚠ WARNING**

**Be careful not to pinch your fingers between the drum and blade.**

### 3.5 Consumable Parts

Replace consumable parts such as filter elements and air cleaner elements during periodical maintenance or before reaching the wear limit. Proper replacement of consumable parts will improve the overall life of the machine, resulting in cost-effective operations.

Use genuine SAKAI parts as replacement parts.

The part numbers are subject to change due to the improvements to the parts.

When ordering parts, make sure to obtain the latest part numbers by checking with our distributorship or one of our certified service shops of the version, model name and model number of the machine in use.

Consumable Part	Part No.	Interval		Remark
		Annual replacement (year)	Replacement per operation (hours)	
Engine oil filter element	4032-39002-0	0.25	250	
Fuel filter element	4033-26003-0	0.5	500	
Fuel pre-filter element	4423-42001-0	0.5	500	
Hydraulic oil line filter element	4211-41001-0		500	2 pieces
Hydraulic oil suction filter element	4208-36000-0		1000	
Air cleaner primary element	4423-35001-0		As needed	
Air cleaner secondary element	4423-35002-0		As needed	They should be replaced with new ones once in every three times of primary elements placement

**3. PERIODIC MAINTENANCE**

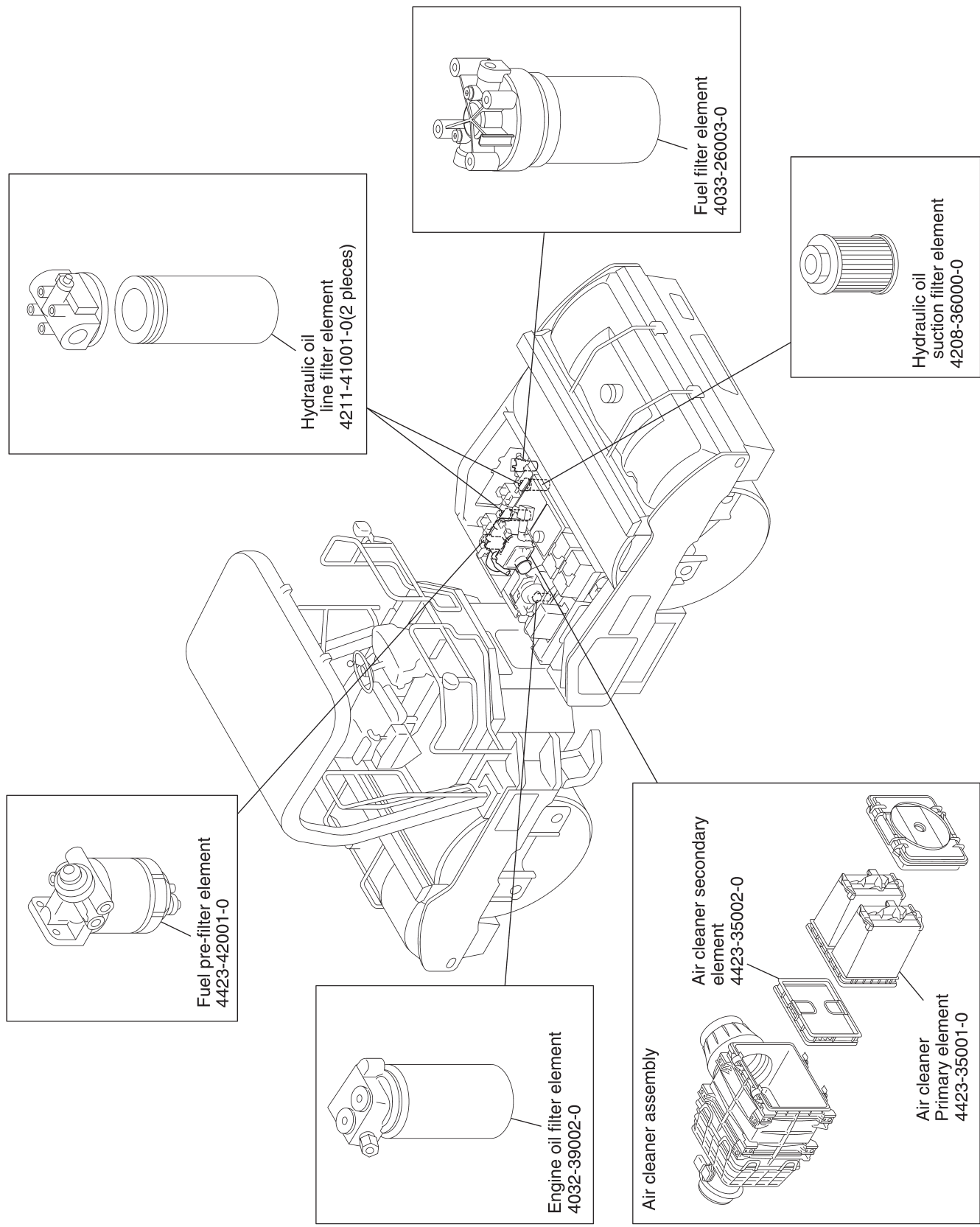

### 3. PERIODIC MAINTENANCE

## 3.6 Fluid and Lubricant Capacities

### (1) General rules

- 1) Never feed water or lubricant with the strainer removed.
- 2) Use recommended lubricant and hydraulic fluid.
- 3) Do not use lubricants and hydraulic fluid of different brands.
- 4) When replacing oil, drain it completely and clean the container with flushing oil before filling new oil.
- 5) When fueling SAKAI machines, be sure to use the fuel that we specify or recommend.  
Nonconformance resulting from use of fuel and lube oil other than those specified or recommended by our company is not covered by our warranty and repair service.

### (2) Capacity

Compartment	Type of fluid	Capacity in liters (gal.)
Fuel tank	Diesel oil	292 (77.1)
Engine oil pan	Engine oil	12 (3.2)
Radiator	Coolant	21 (5.5)
Hydraulic oil tank	Hydraulic oil	61 (16.1)
Gear case (Wheel moter)	Gear oil	3.6 (0.95) x 2
Vibrator	Gear oil	22 (5.8) x 2
Water tank	Water	600 (159) x 2

### (3) Rating

Lubricant	Service classification	Ambient temp. and applicable viscosity rating			Applicable standards
		-15 – 30°C (5 – 86°F) Cold	0 – 40°C (32 – 104°F) Moderate	15 – 55°C (59 – 131°F) Tropical	
Engine oil	API grade CJ-4	SAE 15W-40	SAE 15W-40	SAE 15W-40	MIL-L-2104B
Gear oil	API grade GL5	SAE 80W-90	SAE 90	SAE 140	MIL-L-2105
Hydraulic oil	Anti wear	ISO-VG32 over VI 140	ISO-VG46 over VI 140	ISO-VG68 over VI 110	ISO-3448
Grease	Lithium type extreme pressure				NLGI-2
Fuel	Diesel oil				ASTM D975-2D

### 3. PERIODIC MAINTENANCE

#### (4) Recommended lubricants

Lubricant Oil company	Engine oil API – CJ4	Gear oil API GL 5	Hydraulic oil ISO-VG 46	Grease (NLGI – 2)
CHEVRON	DELO 400 LE	RPM Universal Gear Lubricants	Rando HDZ 46	Martifak EP 2
BP	—	BP Energear HYPO-U	Bartran HV 46	BP Energrease LS – EP 2
CASTROL	Tection Extra	EXP Gear OILS	Castrol Hyspin AWH 46	Castrol Spheerol ELP 2
EXXON MOBIL	Mobil Delvac 1 ESP	Mobilube HD	Mobil DTE 10 Excel 46	Mobilux EP 2
SHELL	Shell Rimula R4 L	Shell Spirax S2 A90	Shell Tellus S2V 46	Shell Alvania Greases EP2

#### **⚠ CAUTION**

- **Fill the fluid reservoirs with the filters installed.**
- **Use recommended fuels and lubricants only.**
- **Use the hydraulic oils which specifications are as clean as ISO4406 18 / 13 or above.**

# 3.7 Electric Wiring Diagram

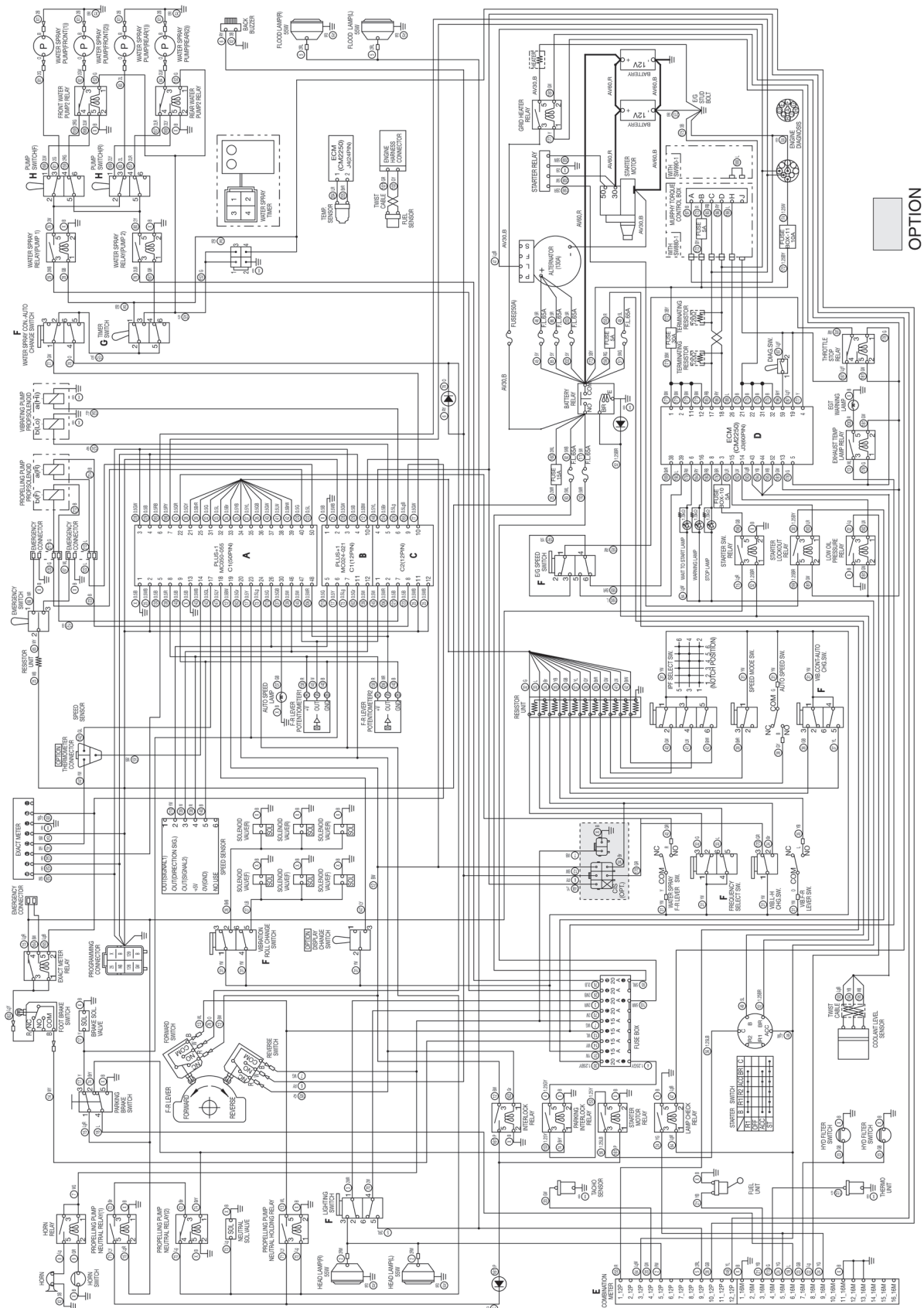

OPTION



**CAUTION: Size of wires not indicated by letters are AVS 0.85.**

**Color of wire**

B	Black	BrR	Brown/ Red stripe	GR	Green/ Red stripe	LR	Blue/ Red stripe	P	Pink	RW	Red/ White stripe	WR	White/ Red stripe	YR	Yellow/ Red stripe	LB	Blue/ Black stripe
BR	Black/ Red stripe	BrW	Brown/ White stripe	GW	Green/ White stripe	LW	Blue/ White stripe	R	Red	FY	Red/ Yellow stripe	Y	Yellow/ White stripe	YW	Yellow/ White stripe	WG	White/ Green stripe
BW	Black/ White stripe	G	Green	GY	Green/ Yellow stripe	LY	Blue/ Yellow stripe	RB	Red/ Black stripe	W	White	YB	Yellow/ Black stripe	BrY	Brown/ Yellow stripe		
BY	Black/ Yellow stripe	GB	Green/ Black stripe	Gr	Gray	Lg	Light green	RG	Red/ Green stripe	WB	White/ Black stripe	YG	Yellow/ Green stripe	Sb	Blue		
Br	Brown	GL	Green/ Blue stripe	L	Blue	O	Orange	RL	Red/ Blue stripe	WL	White/ Blue stripe	YL	Yellow/ Blue stripe	BG	Black/ Green stripe		

**DETAIL A**

PLUS+1 MC060-065  
C1 (50PIN)

1	GND (-)
2	(+) POWAR
3	CAN0+
4	CAN0-
5	AIN / CAN0 SHIELD
6	CAN1+
7	CAN1-
8	3.3 / 5VDC SENSOR (+)
9	SENSOR GND (-)
10	1.66VDC SENSOR (+)
11	CAN2+
12	CAN2-
13	AIN / CAN1 SHIELD
14	AIN / CAN2 SHIELD
15	DIN / AIN
16	DIN / AIN
17	DIN / AIN
18	DIN / AIN
19	DIN / AIN
20	DIN / AIN
21	DIN / AIN
22	DIN / AIN
23	DIN / AIN
24	DIN / AIN
25	DIN / AIN

**DETAIL B**

PLUS+1 MC024-021  
C1 (12PIN)

1	GND (-)
2	(+) POWAR
3	CAN+
4	CAN-
5	AIN / CAN SHIELD
6	DIN
7	DIN
8	5VDC SENSOR (+)
9	SENSOR GND (-)
10	DIN / AIN / FREQIN
11	DIN / AIN / FREQIN
12	DIN / AIN / FREQIN

**DETAIL C**

PLUS+1 MC024-021  
C2 (12PIN)

1	DIN / AIN / FREQIN
2	DIN / AIN / FREQIN
3	PWMOUT / DOUT / PVG POWER 1
4	PWMOUT / DOUT / PVG POWER 2
5	PWMOUT / DOUT / PVGOUT 1
6	PWMOUT / DOUT / PVGOUT 1
7	PWMOUT / DOUT / PVGOUT 1
8	PWMOUT / DOUT / PVGOUT 2
9	PWMOUT / DOUT / PVGOUT 2
10	PWMOUT / DOUT / PVGOUT 2
11	(+) POWAR
12	(+) POWAR

**DETAIL D**

ECM (CM2250)  
J3(60PIN)

1	(+) BATTERY
2	(+) BATTERY
3	KEY SWITCH
4	INTAKE AIR HEATER +
5	DUAL OUTPUT B
6	WAIT TO START LAMP
8	STOP LAMP
11	(+) BATTERY
12	(+) BATTERY
13	OUTPUT RETURN 1 (-) FOR OIL PRESS.
14	DUAL OUTPUT A (+) FOR OIL PRESS.
15	STARTER LOCKOUT
16	WARNING LAMP
17	J1939 CAN (+)
18	J1939 CAN (-)
19	SWITCH RETURN
21	BATTERY (-)
22	BATTERY (-)
26	OEM SWITCH
28	CRUISE CONTROL RESUME / INCREMENT SW
29	CRUISE CONTROL SET / DECREMENT SW
31	BATTERY (-)
33	TACHOMETER
32	BATTERY (-)
38	ISC2 SW (MID)
39	ISC1 SW (FULL)
43	OEM SENSOR (SIGNAL RETURN)
44	COOLANT LEVEL (SIGNAL)
52	SENSOR SUPPLY (POWER)
59	DIAGNOSTIC SWITCH

**DETAIL E**

COMBINATION METER SWP-12M

1	12V (+)	R
2	24V (+)	R
3	KEY SW. (ACC)	P
4	REV PULSE INPUT *1	O
5	LIGHTING	WR
6	TURN SIGNAL (R)	GL
7	TURN SIGNAL (L)	LR
8	POSITION LIGHT	YL
9	FLOOD LAMP	LW
10	WATER SPRAY	Br
11	LIQUIT SPRAY	LB
12	VIBRATING	L

REV RATIO SEL.  
127 PULSE / REV SET (NO.7)  
TEMP CURVE SEL.  
TEMP. 50-103°C SET (NO.0)

COMBINATION METER SWP-12M

1	GND	B
2	REV PULSE INPUT *2	Y
3	FUEL METER	YR
4	TEMP. METER	YW
5	LAMP CHECK	BrW
6	PARKING BRAKE	GR
7	HYD. FILTER	GW
8	OIL. PRESSURE	G
9	ELEC. CHG. WARNING	W
10	GLOW	GY
11	REV RATIO SEL.1	GND
12	REV RATIO SEL.2	GND
13	REV RATIO SEL.3	GND
14	REV RATIO SEL.4	OPEN
15	TEMP. CURVE SEL.1	OPEN
16	TEMP. CURVE SEL.2	OPEN

**3. PERIODIC MAINTENANCE**

### 3. PERIODIC MAINTENANCE

## 3.8 Fuse Box and Line Fuse

### Fuse Box

The fuse box houses five 20A-, four 15A-, one 10A- and two 5A- fuses lined up with spares fitted for 30A-, 20A-, 15A- and 10A- fuses. Only SW880-1 have one 5A- fuse to out of fuse box houses. See page 39.

### Line Fuse

The line fuse holders 30A-, 10A-, 5A- fuse are located on the side of the battery. See page 39.

#### **CAUTION**

**Use fuses of correct capacity.**

**NOTE:** When a fuse is burned, determine the cause before replacing.

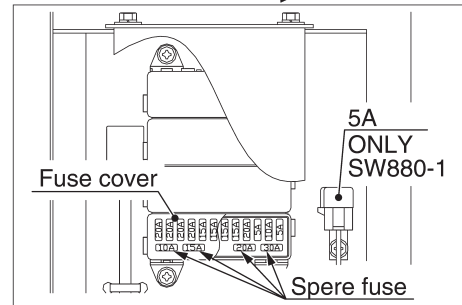
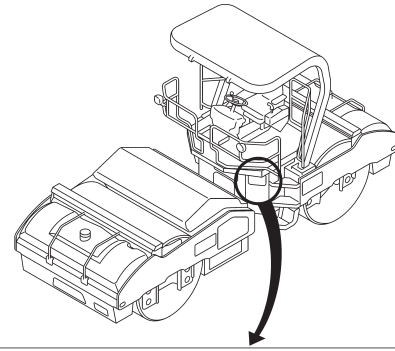

## 3.9 Battery

- 1) Leaving the battery unused for long without attention or using its power excessively at a time can cause damage to the plates, leading to a shortened life.
- 2) For long-term storage, charge it fully, store in a cool and dry place, and check the level of charge at least once a month.
- 3) Maintain the level of charge above 75%.
- 4) In cold weather, it is desirable to start the engine with the battery charged 100%. Do not try to start the engine with less than 75%.

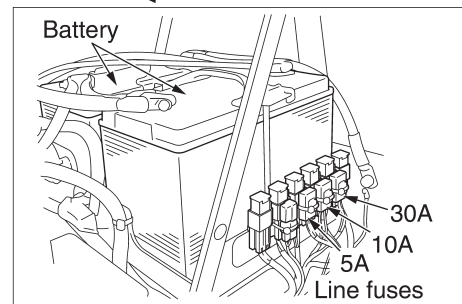
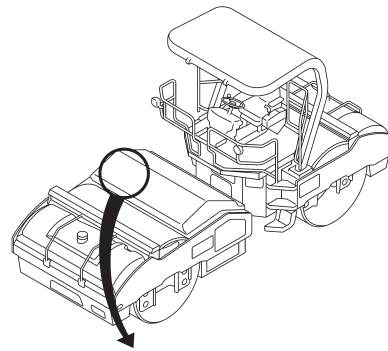

### 3. PERIODIC MAINTENANCE

#### **⚠ WARNING**

- The battery contains diluted sulfuric acid, which will dissolve clothes and skin. Should you get battery fluid on your clothes or skin, wash it off immediately with copious quantities of clean water.
- If you get it in your eyes, rinse them straight away with clean water and immediately seek the help of a doctor.
- If you accidentally ingest it, drink copious quantities of water and immediately seek the help of a doctor.
- Always wear safety glasses when handling the battery.
- The battery generates hydrogen gas, so there is a danger of explosions. Avoid recharging the battery, keep cigarettes and flames away, etc., in poorly ventilated places when there is a danger of generating sparks.
- The inspection and handling of batteries should be carried out with the engine turned off and the starter switch in the "OFF" position.
- Be careful not to accidentally connect the two battery terminals with tools or other metallic objects.
- Tangled terminals may generate sparks due to improper connections, resulting in the danger of explosions. Make sure terminals are connected firmly.
- The battery is for starting the engine and operating electrical equipment on the machine. Do not use it for any other purpose.

#### **⚠ CAUTION**

The power-supply voltage of this machine is 12V.

## 4. SPECIFICATIONS

### 4 SPECIFICATIONS

#### (1) SW880-1

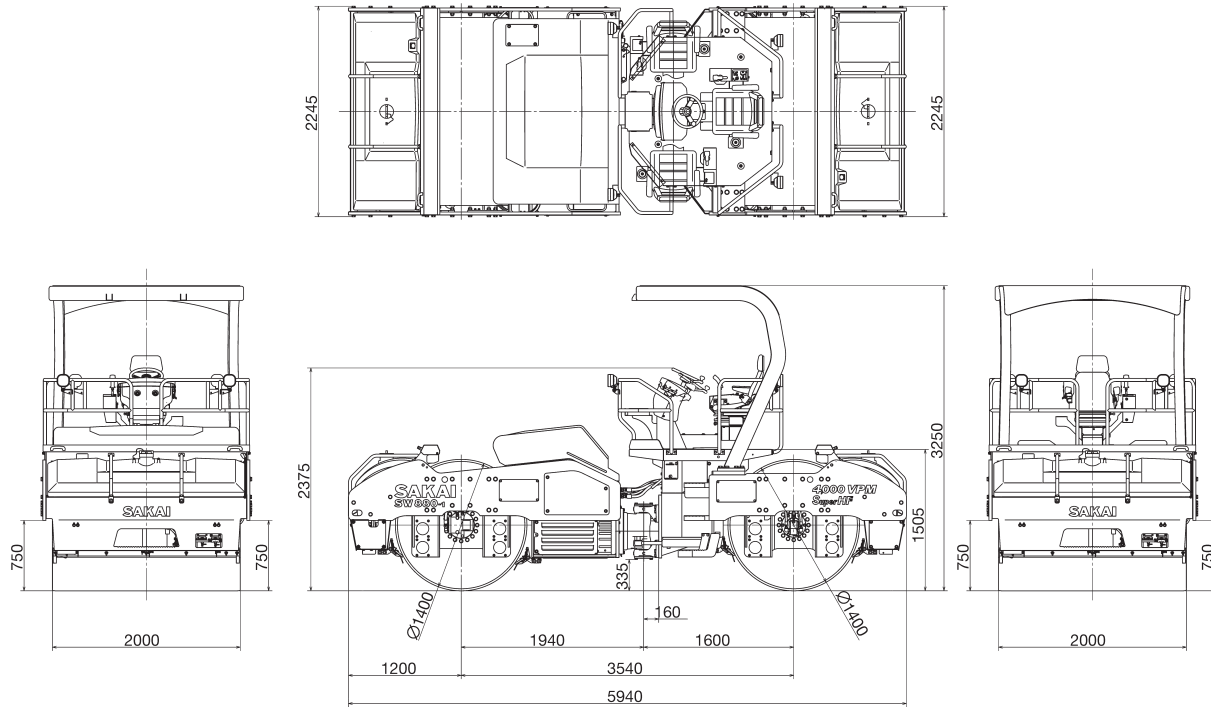

<b>Model</b>	<b>SW880-1</b>		
<b>Operating Weight</b>			
Operating weight	12,870 kg (28,375 lbs)		
On front axle	6,340 kg (13,975 lbs)		
On rear axle	6,530 kg (14,395 lbs)		
<b>Dimension</b>			
Overall length	5,940 mm (234")		
Overall width	2,245 mm ( 88")		
Overall height	3,250 mm (128")		
Wheelbase	3,540 mm (139")		
Wheel			
Front	Roll (dia. x width) 1,400 x 2,000 mm (55" x 79")		
Rear	Roll (dia. x width) 1,400 x 2,000 mm (55" x 79")		
<b>Performance</b>			
Travel speed	1st 2500 vpm 0 – 4.5 km/h (0 – 2.8 mile/h) 3000 vpm 0 – 5.5 km/h (0 – 3.4 mile/h) 4000 vpm 0 – 7.2 km/h (0 – 4.5 mile/h) 2nd 0 – 11 km/h (0 – 6.8 mile/h)		
<b>Vibrating power</b>			
Gradability	29 % (16°)		
Rolling width	2,000 mm (79")		
Minimum turning radius	6.4 m (252")		
<b>Vibrating power</b>			
Low amplitude			
Frequency	66.7 Hz {4,000 vpm}	50.0 Hz {3,000 vpm}	41.7 Hz {2,500 vpm}
Centrifugal force	160 kN (35,970 lbs)	90 kN (20,230 lbs)	63 kN (14,160 lbs)
High amplitude			
Frequency	50.0 Hz {3,000 vpm}	41.7 Hz {2,500 vpm}	
Centrifugal force	177 kN (39,790 lbs)	123 kN (27,650 lbs)	
<b>Engine</b>			
Model	CUMMINS "QSB4.5" Diesel Engine with turbo charger		
Total displacement	4.457 liters (272 cu.in)		
Rated output	107.6 kW {144 HP} / 2,500 min <sup>-1</sup> {rpm}		
Max. torque	624 N·m / 1,500 min <sup>-1</sup> {rpm}		
<b>Tank capacity</b>			
Fuel tank	292 liters (77.1 gal)		
Hydraulic tank	61 liters (16.1 gal)		
Sprinkler tank	600 liters (159 gal) x 2		

**NOTE:** 1) Gradability is the calculated value. It may vary with ground surface conditions.

2) According to European Standards (EN500-1, ISO 6165, etc.), the mass are defined as follows.

Operating mass : Fuel=50%, Water=50%, Operator=75kg.

## 4. SPECIFICATIONS

### (2) SW990-1

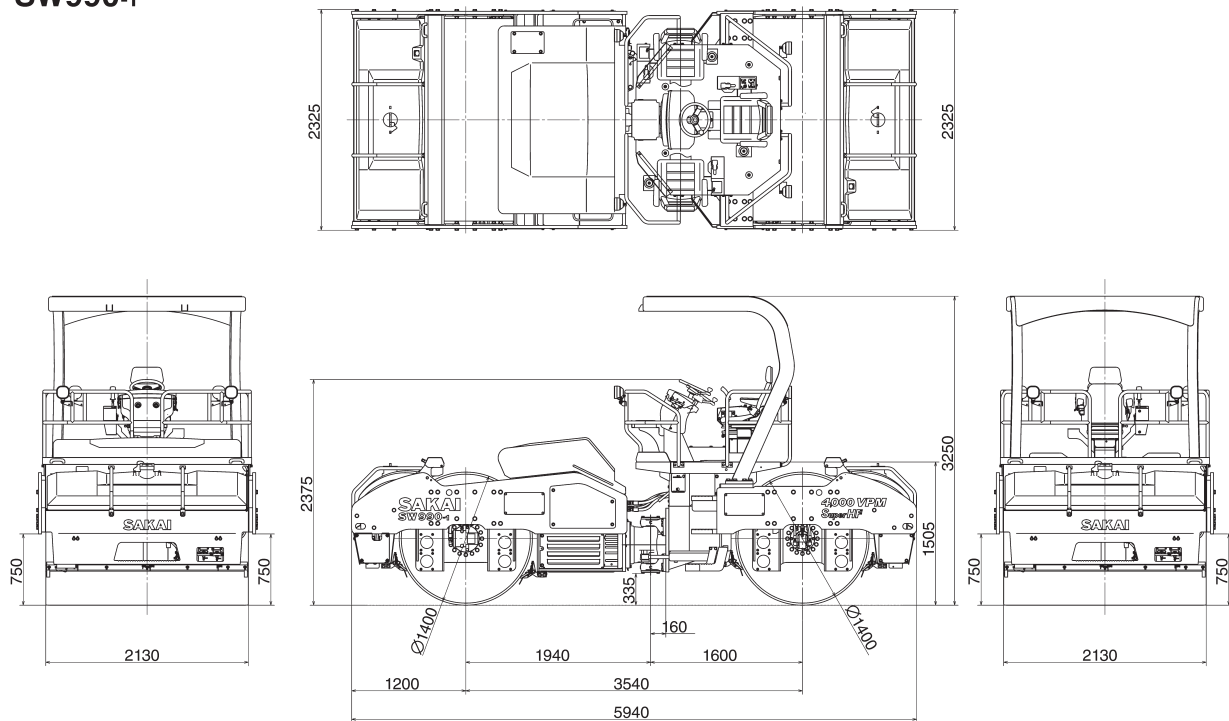

Model	SW990-1		
<b>Operating Weight</b>			
Operating weight	13,250 kg (29,210 lbs)		
On front axle	6,520 kg (14,375 lbs)		
On rear axle	6,730 kg (14,835 lbs)		
<b>Dimension</b>			
Overall length	5,940 mm (234")		
Overall width	2,325 mm ( 92")		
Overall height	3,250 mm (128")		
Wheelbase	3,540 mm (139")		
Wheel			
Front	Roll (dia. x width) 1,400 x 2,130 mm (55" x 84")		
Rear	Roll (dia. x width) 1,400 x 2,130 mm (55" x 84")		
<b>Performance</b>			
Travel speed	1st 2500 vpm 0 – 4.5 km/h (0 – 2.8 mile/h) 3000 vpm 0 – 5.5 km/h (0 – 3.4 mile/h) 4000 vpm 0 – 7.2 km/h (0 – 4.5 mile/h) 2nd 0 – 11 km/h (0 – 6.8 mile/h)		
<b>Vibrating power</b>			
Gradability	28 % (15°)		
Rolling width	2,130 mm (84")		
Minimum turning radius	6.5 m (256")		
<b>Vibrating power</b>			
Low amplitude			
Frequency	66.7 Hz {4,000 vpm}	50.0 Hz {3,000 vpm}	41.7 Hz {2,500 vpm}
Centrifugal force	173 kN (38,890 lbs)	98 kN (22,030 lbs)	68 kN (15,285 lbs)
High amplitude			
Frequency	50.0 Hz {3,000 vpm}	41.7 Hz {2,500 vpm}	
Centrifugal force	185 kN (41,590 lbs)	128 kN (28,775 lbs)	
<b>Engine</b>			
Model	CUMMINS "QSB4.5" Diesel Engine with turbo charger		
Total displacement	4.457 liters (272 cu.in)		
Rated output	122 kW {164 HP} / 2,500 min <sup>-1</sup> {rpm}		
Max. torque	632 N·m / 1,500 min <sup>-1</sup> {rpm}		
<b>Tank capacity</b>			
Fuel tank	292 liters (77.1 gal)		
Hydraulic tank	61 liters (16.1 gal)		
Sprinkler tank	600 liters (159 gal ) x 2		

**NOTE:** 1) Gradability is the calculated value. It may vary with ground surface conditions.

2) According to European Standards (EN500-1, ISO 6165, etc.), the mass are defined as follows.

Operating mass : Fuel=50%, Water=50%, Operator=75kg.

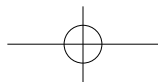
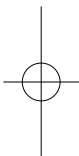
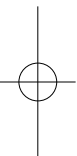
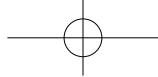

**SAKAI HEAVY INDUSTRIES, LTD.**

Head Office: 1-4-8, Shiba Daimon, Minato-ku,  
Tokyo, Japan

Telephone: 81-3-3431-9971

Facsimile: 81-3-3436-6212

Printed in Japan 2015 02. dataonly ①©