

SW880/990

SHOP MANUAL

SAKAI®

3498-65684-0

Introduction

This manual provides important information to familiarize you with safe operating and maintenance procedures for your SAKAI roller. Even though you may be familiar with similar equipment you must read and understand this manual before operating or servicing this unit.

Safety is everyone's business and it is one of your primary concerns. Knowing the guidelines presented in this manual will help provide for your safety, for the safety of those around you and for the proper operation and maintenance of the machine. Improper operation is dangerous and can result in injury or death.

Sakai Heavy Industries cannot foresee all possible circumstances or varying conditions to which the operator, serviceman or machine may be exposed to that might lead to a potential hazard. Therefore, the warnings and cautions listed in this manual and those placed on the machine are not intended to be all inclusive and liability for personal injury or damage to equipment or property cannot be assumed.

CONTENTS

1. SAFETY

1. GENERAL SAFETY	1-001
1-1. Understanding the Safety Symbols and Words	1-001
1-2. General	1-001
1-3. Qualifications of Operators and Maintenance Personnel	1-002
1-4. Safety Practices and Policies	1-002
1-5. Pre Start Inspection	1-003
1-6. Safety Instructions	1-003
1-7. Starting	1-004
1-8. Operating	1-004
1-9. Stopping	1-004
1-10. Maintenance	1-005
1-11. Transporting the Machine	1-007

2. SPECIFICATIONS

1. SPECIFICATION DATA	2-001
1-1. SW880	2-001
1-2. SW990	2-003
2. TABLE OF STANDARD VALUES	2-005
2-1. Engine	2-005
2-2. Drive	2-005
2-3. Hydraulic System	2-006
2-4. Steering	2-006
2-5. Brakes	2-007
2-6. Water System	2-007
2-7. Oil and Grease Capacity	2-007
3. FUEL AND LUBRICANTS SPECIFICATION	2-008
3-1. Rating	2-008
3-2. Recommended Lubricants	2-008
4. TIGHTENING TORQUE CHART	2-009

3. ENGINE AND CONTROLS

1. ENGINE	3-001
1-1. Engine Mount	3-001
1-1-1. Engine mount (SW880)	3-001
1-1-2. Engine mount (SW990)	3-002

1-2. Engine Exterior	3-003
1-2-1. Engine exterior (SW880)	3-003
1-2-2. Engine exterior (SW990)	3-004
1-3. Fuel System	3-005
1-4. Cooling System	3-006
2. CONTROL SYSTEM	3-007
2-1. Forward-reverse Control	3-007
2-2. Adjustment of Forward-reverse Lever Potentiometer	3-008
2-2-1. Adjustment	3-008
3. PUMP MOUNT	3-009
3-1. Pump Mount	3-009
3-2. Installation of Pump	3-010

4. HYDRAULIC SYSTEMS

1. SYSTEM CIRCUIT DIAGRAM	4-001
1-1. Graphic Symbols for Hydraulic Circuits	4-001
1-2. Hydraulic Circuit Diagram	4-003
2. PROPULSION HYDRAULIC SYSTEM	4-004
2-1. Propulsion Hydraulic Piping (1)	4-004
2-2. Propulsion Hydraulic Piping (2)	4-005
2-3. Hydraulic Component Specifications	4-006
2-3-1. Hydraulic pump assembly (propulsion + vibrator)	4-006
2-3-2. Internal structure of hydraulic pump (propulsion pump)	4-008
2-3-3. Internal structure of hydraulic pump (vibrator pump)	4-012
2-3-4. Propulsion hydraulic motor (front)	4-016
2-3-5. Internal structure of propulsion hydraulic motor (front)	4-017
2-3-6. Propulsion hydraulic motor (rear)	4-018
2-3-7. Internal structure of propulsion hydraulic motor (rear)	4-019
2-3-8. Valve block	4-020
3. VIBRATOR HYDRAULIC SYSTEM	4-021
3-1. Vibrator Hydraulic Piping (1)	4-021
3-2. Vibrator Hydraulic Piping (2)	4-022
3-3. Hydraulic Component Specifications	4-023
3-3-1. Vibrator hydraulic motor	4-023
3-3-2. Internal structure of vibrator motor	4-024
3-3-3. Valve block	4-025
4. STEERING SYSTEM	4-027
4-1. Steering Hydraulic Piping	4-027
4-1-1. Steering pump	4-028

4-1-2. Internal structure of steering pump	4-029
4-2. Steering Wheel	4-030
4-2-1. Steering valve (orbitrol)	4-031
4-3. Steering Cylinder	4-032
4-3-1. Internal structure of steering cylinder	4-033
4-4. Frame (Center Pin)	4-034

5. ELECTRICAL SYSTEM

1. GENERAL SYSTEM CIRCUIT DIAGRAM	5-001
1-1. Electrical Wiring Diagram	5-001
1-1-1. Engine-related electrical wiring diagram	5-002
1-1-2. Vehicle-related electrical wiring diagram (vehicle control unit)	5-003
1-1-3. Vehicle-related electrical wiring diagram	5-004
2. ELECTRICAL COMPONENTS	5-005
2-1. Electrical Component Layout (1)	5-005
2-2. Electrical Component Layout (2)	5-006
2-3. Battery Layout	5-008
3. ELECTRICAL COMPONENT SPECIFICATIONS	5-009
3-1. Fuse Box	5-009
3-2. Vehicle Control (V/C)	5-010
3-3. Control Box (EMR 3)	5-011
3-4. Resistor	5-012
3-5. Combination Meter	5-013
3-6. Exact Meter	5-014
3-7. Potentiometer	5-015
3-8. Lever Switch	5-016

6. VIBRATORY DRUM

1. PRECAUTIONS FOR DISASSEMBLY AND REASSEMBLY	6-001
2. VIBRATORY DRUM	6-003
2-1. Removal and Installation of Vibratory Drum	6-003
2-1-1. Removal of vibratory drum	6-003
2-1-2. Installation of vibratory drum	6-009
2-2. Vibratory Drum Assembly	6-010
2-2-1. Vibratory drum assembly	6-010
2-2-2. Vibratory drum exploded diagram	6-011
2-3. Disassembly and Reassembly of Vibratory Drum	6-012
2-3-1. Disassembly of vibratory drum	6-012
2-3-2. Reassembly of vibratory drum	6-026

7. BRAKES

1. BRAKE SYSTEM	7-001
1-1. Brake Pedal	7-001
1-2. Brake Circuit Configuration	7-002

8. OPERATOR STATION

1. FLOORBOARD	8-001
1-1. Operator Station	8-001
1-2. Structure of Operator Station	8-002
1-3. Adjustment of Swivel Lock Release Pedal	8-003

9. WATER SPRAY SYSTEM

1. WATER SPRAY SYSTEM	9-001
1-1. Water Spray System	9-001
1-2. Water Spray Pump	9-002

10. INSPECTION AND ADJUSTMENT

1. INSPECTION AND ADJUSTMENT	10-001
1-1. Inspection and Adjustment	10-001
1-1-1. Safety precautions for inspection and adjustment	10-001
1-1-2. Preparation for inspection and adjustment	10-002
1-1-3. Precautions for inspection and adjustment	10-002
1-1-4. Warm-up	10-002
2. MEASUREMENT AND ADJUSTMENT OF PROPULSION CIRCUIT PRESSURE	10-003
2-1. Measurement	10-003
2-2. Adjustment	10-004
2-2-1. If the pressures on both the forward and reverse sides deviate from the maximum circuit pressure range by the same value	10-004
2-2-2. If the pressure on either the forward or reverse side deviates from the maximum circuit pressure range	10-005
3. MEASUREMENT AND ADJUSTMENT OF PROPULSION CHARGE CIRCUIT PRESSURE	10-006
3-1. Measurement	10-006
3-2. Adjustment	10-007
4. MEASUREMENT OF PROPULSION SERVO CIRCUIT PRESSURE	10-008
4-1. Measurement	10-008
5. MEASUREMENT OF PARKING BRAKE RELEASE PRESSURE	10-009
5-1. Measurement	10-009

6. MEASUREMENT AND INSPECTION OF VIBRATOR CIRCUIT PRESSURE	10-010
6-1. Measurement	10-010
6-2. Inspection	10-011
6-2-1. Inspection of the high-pressure relief valves installed in the vibrator pump	10-011
6-2-2. Inspection of the high-pressure relief valves (port relief valves) installed in the valve blocks in the vibrator circuit	10-012
7. MEASUREMENT AND INSPECTION OF VIBRATION CHARGE CIRCUIT PRESSURE	10-013
7-1. Measurement	10-013
7-2. Inspection	10-014
8. MEASUREMENT AND INSPECTION OF STEERING CIRCUIT PRESSURE	10-015
8-1. Measurement	10-015
8-2. Inspection	10-016

11. TROUBLESHOOTING

1. TROUBLESHOOTING	11-001
1-1. Safety Precautions for Troubleshooting	11-001
1-2. Important Information for Troubleshooting	11-002
1-3. Before Starting	11-002
1-4. Wire Color Code and Number	11-002
2. ELECTRICAL SYSTEM TROUBLESHOOTING	11-003
2-1. When Performing Electrical System Fault Diagnosis	11-003
2-1-1. Safety rules and precautions to take during electric circuit fault diagnosis	11-003
2-1-2. Inspection procedures using a tester	11-004
2-1-3. Inspection of electrical system	11-008
2-2. Blink Codes	11-010
2-2-1. Description of blink codes	11-010
2-2-2. Blink code list	11-011
2-3. Error Codes	11-015
2-3-1. Description of error codes	11-015
2-3-2. Error code list	11-015
2-4. Engine	11-017
2-4-1. Engine will not start (1/8)	11-017
2-4-1. Engine will not start (2/8)	11-019
2-4-1. Engine will not start (3/8)	11-021
2-4-1. Engine will not start (4/8)	11-023
2-4-1. Engine will not start (5/8)	11-025

2-4-1. Engine will not start (6/8)	11-027
2-4-1. Engine will not start (7/8)	11-029
2-4-1. Engine will not start (8/8)	11-031
2-4-2. Insufficient output of engine or engine malfunction (1/2)	11-033
2-4-2. Insufficient output of engine or engine malfunction (2/2)	11-035
2-4-3. No charging	11-037
2-4-4. Engine speed cannot be switched	11-039
2-4-5. Glow plug is not heated (Engine starting performance is bad)	11-041
2-4-6. Engine check lamp does not illuminate	11-043
2-4-7. CAN communication is abnormal	11-045
2-5. Propulsion	11-047
2-5-1. Vehicle moves neither forward nor backward (1/5)	11-047
2-5-1. Vehicle moves neither forward nor backward (2/5)	11-049
2-5-1. Vehicle moves neither forward nor backward (3/5)	11-051
2-5-1. Vehicle moves neither forward nor backward (4/5)	11-053
2-5-1. Vehicle moves neither forward nor backward (5/5)	11-055
2-5-2. Vehicle moves neither forward nor backward only in automatic speed mode	11-057
2-5-3. Vehicle speed cannot be changed	11-059
2-5-4. Automatic speed function does not work (1/7)	11-061
2-5-4. Automatic speed function does not work (2/7)	11-063
2-5-4. Automatic speed function does not work (3/7)	11-065
2-5-4. Automatic speed function does not work (4/7)	11-067
2-5-4. Automatic speed function does not work (5/7)	11-069
2-5-4. Automatic speed function does not work (6/7)	11-071
2-5-4. Automatic speed function does not work (7/7)	11-073
2-5-5. Brake cannot be released	11-075
2-5-6. Brake does not operate	11-077
2-5-7. Emergency exit propulsion cannot be performed	11-079
2-6. Vibration	11-081
2-6-1. No vibration occurs (1/2)	11-081
2-6-1. No vibration occurs (2/2)	11-083
2-6-2. Vibration frequency cannot be switched (1/2)	11-085
2-6-2. Vibration frequency cannot be switched (2/2)	11-087
2-6-3. High/low-vibration cannot be switched	11-089
2-6-4. Continuous/automatic-vibration mode cannot be switched	11-091
2-6-5. Front and rear vibratory drums cannot perform one-drum vibration	11-093
2-7. Exact Meter	11-095
2-7-1. Exact meter indicator lamp does not illuminate (during driving) (1/2)	11-095

2-7-1. Exact meter indicator lamp does not illuminate (during driving) (2/2).....	11-097
2-7-2. No vehicle speed indication on the display.....	11-099
2-8. Water Spray.....	11-101
2-8-1. Continuous water spray cannot be performed (1/4).....	11-101
2-8-1. Continuous water spray cannot be performed (2/4).....	11-103
2-8-1. Continuous water spray cannot be performed (3/4).....	11-105
2-8-1. Continuous water spray cannot be performed (4/4).....	11-107
2-8-2. Continuous water spray works, but intermittent water spray cannot be performed.....	11-109
2-8-3. Continuous water spray works, but automatic water spray cannot be performed.....	11-111
2-9. Lighting.....	11-113
2-9-1. Headlamps and working lamps do not light.....	11-113
2-9-2. Illumination of combination meter does not turn on.....	11-115
2-9-3. Combination meter warning lamp or indicator lamp is abnormal.....	11-115
2-9-4. Tachometer reading is abnormal (1/2).....	11-117
2-9-4. Tachometer reading is abnormal (2/2).....	11-119
2-9-5. Hour meter is abnormal.....	11-119
2-9-6. Temperature gauge is abnormal.....	11-121
2-9-7. Fuel gauge is abnormal.....	11-123
2-9-8. Hydraulic oil filter warning lamp remains ON.....	11-123
2-9-9. Oil pressure warning lamp remains ON.....	11-125
2-9-10. Charge warning lamp remains ON.....	11-127
2-9-11. Vibration indicator lamp does not light.....	11-127
2-9-12. Water spray indicator lamp does not light.....	11-129
2-9-13. Working lamp indicator lamp does not light.....	11-131
2-9-14. Parking brake indicator lamp does not light.....	11-131
2-9-15. Horn does not sound.....	11-133
2-9-16. Back buzzer does not sound.....	11-133
3. HYDRAULIC SYSTEM TROUBLESHOOTING.....	11-134
3-1. When Performing Hydraulic System Troubleshooting.....	11-134
3-2. Propulsion.....	11-135
3-2-1. Vehicle moves neither forward nor backward (1/2).....	11-135
3-2-1. Vehicle moves neither forward nor backward (2/2).....	11-136
3-2-2. Vehicle moves in one direction only (forward or backward).....	11-136
3-2-3. Slow vehicle speed or small drive force.....	11-136
3-2-4. Vehicle does not stop completely with forward/reverse lever in neutral position.....	11-137
3-2-5. Propulsion system is overheating.....	11-137

3-2-6. Abnormal noise from propulsion system	11-137
3-3. Vibrator System	11-138
3-3-1. No vibration	11-138
3-3-2. Only front or rear vibratory drum can vibrate (two-drum vibration cannot be performed)	11-139
3-3-3. Vibrator frequency is too low	11-139
3-3-4. Amplitude cannot be switched between high and low	11-139
3-3-5. Vibrator does not stop	11-140
3-3-6. Vibrator system is overheating	11-140
3-3-7. Abnormal noise from vibrator system	11-140
3-4. Steering	11-141
3-4-1. Steering wheel is hard to turn	11-141
3-4-2. Steering response is slow	11-141
3-4-3. Steering wheel backlash or play is large	11-142
3-4-4. Steering system is overheating	11-142
3-4-5. Abnormal noise from steering system	11-142

SAFETY

1. GENERAL SAFETY

1-1. Understanding the Safety Symbols and Words

The words DANGER, WARNING, and CAUTION are used with the safety-alert symbol. DANGER identifies the most serious hazard. When the symbols DANGER, WARNING and CAUTION are displayed, become alert. Your safety or those around you may be involved. NOTICE is used to provide important information that is not hazard related.

 **DANGER:** Indicates an imminently hazardous situation or condition which if not avoided can result in serious personal injury or death.

 **WARNING:** Indicates a potentially hazardous situation or condition which if not avoided can result in serious personal injury or death.

 **CAUTION:** Indicates a potentially hazardous situation or condition which if not avoided may result in moderate personal injury or damage to the machine or personal property.

(NOTICE): Indicates important information about operation or maintenance of the machine that may cause damage, breakdown, or shortened service life of the machine if you fail to observe or important point to maintain of quality in maintenance works.

★: Indicates standard value to judge whether measured value is good or not.



Items that indicate the weight of a part or equipment and require attention in wire selection and operating posture for slinging operation.



In the assembly operation, tightening torque in locations that require particular attention.

1-2. General

- Operators and maintenance personnel must be alert to recognize and avoid potential hazards. They should also have comprehensive training, the required skills and necessary tools to perform the job safely.
- The machine was built in accordance to the latest safety standards and recognized safety rules. Nevertheless, misuse of the machine may result in risk to life and limb of the user or nearby personnel and may cause damage to the machine or other property.
- The machine must only be used for its intended purpose as described in the Operator's Manual. It must be operated by safety-conscious persons who are fully aware of the risks involved when operating the machine. Any malfunctions especially those affecting the safety of the machine must be corrected immediately.

- The machine is designed specifically for the compaction of asphalt or soil road construction materials. Use of the machine for other purposes such as towing other equipment is considered contrary to the designated use. The manufacturer cannot be responsible or held liable for any damage resulting from such use. The risk for such use lies entirely with the user.
- Operating the machine within the limits of its designated use also involves compliance with the inspection and maintenance requirements contained in the Operation and Maintenance Manual.

1-3. Qualifications of Operators and Maintenance Personnel

- Work on the machine must be performed by qualified personnel only. Individual responsibilities of personnel regarding operation, maintenance, repair of the machine must be clearly stated.
- Define the operator's responsibilities; the operator should have authority to refuse instructions that are contrary to safety.
- Do not allow persons being trained to operate or perform maintenance on the machine without constant supervision by an experienced person.
- Work on the electrical system of the machine must be done only by an experienced person or under the guidance of a skilled electrician and according to electrical engineering rules and regulations.
- Work on the frame, brakes, hydraulic and steering systems must be performed by skilled personnel with special knowledge and training for such work.

1-4. Safety Practices and Policies

- Keep the manuals in the container provided on the machine. Manuals must always be available at the site where the machine is being used.
- The operator or user of the machine must be aware of all applicable or legal and mandatory regulations relevant to accident prevention and environmental protection. These regulations may also deal with handling of hazardous substances, the required proper personal safety and protective equipment and traffic or jobsite regulations.
- Machine operating instructions should also be supplemented with detailed instructions pertaining to the specific jobsite or work location.
- Always be sure the persons working on the machine have read the operating instructions and all safety precautions before beginning work. Reading safety instructions after work has already begun is too late.
- Wear close fitting garments and always tie back and secure long hair, also avoid wearing jewelry such as rings. Injury can result from loose clothing, hair or jewelry being caught up in the machinery or rotating parts.
- Use protective equipment as required by the circumstances or by law.

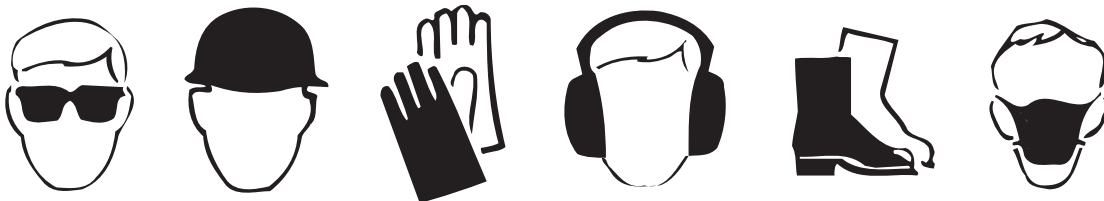

- Observe all safety instructions and warnings attached to the machine.
- Make sure all safety instructions and warnings on the machine are complete and perfectly legible.
- Stop the machine immediately in the event of any malfunction. Report any malfunction immediately to the supervisor or other person of authority.
- Never perform service or maintenance on the machine unless the drums are adequately blocked, articulation lock bar and pin is in the locked position and the parking brake is applied.
- Never make any modifications to the machine which might affect safety without the manufacturer's approval.
- Always perform the recommended routine inspections and adjustments according to the prescribed intervals.

1-5. Pre Start Inspection

- Inspect your machine daily. Ensure that the routine maintenance and lubrication are properly performed. Repair or replace any malfunctioning, broken or missing parts before using the machine. Refer to the maintenance schedule in the Operator's Manual.
- Check that all instructions and safety stickers are in place and readable.
- Never fill the fuel tank with the engine running or while near an open flame or while smoking.
- Always clean up any spilled fuel.
- Check for any warning tags placed on the machine, do not operate the machine until all repairs have been made and warning tags have been removed by authorized personnel.
- Check the seat belt for wear or damage; inspect the belt hardware and fabric. Replace if hardware is damaged or the belt is frayed or nicked or stitching is loose. Check that mounting hardware is tight.
- Clean the steps and operating platform of dirt and foreign matter to reduce danger of slipping.
- Know how to shut-down or stop the machine immediately in case of emergency.
- Know the capabilities and limitations of the machine such as speed, gradeability, steering and braking.
- Be aware of the dimensions of the machine such as height, weight especially for transporting.

1-6. Safety Instructions

- Take all necessary precautions to ensure that the machine is used only when in a safe and reliable condition.
- Avoid any operational mode that might compromise safety.
- Operate the machine only if all protective and safety devices are in place and fully functional.
- Always use the hand rails and steps to get on and off your machine maintaining 3-point contact (using both hands).

1-7. Starting

- Start the machine only from the driver's seat and always wear the seat belt.
- Watch that the warning lights and indicators during start-up and shutdown are working in accordance with operating instructions.
- Watch that no one is in danger before starting and when moving the machine.
- Check that braking, steering, signals and lights are fully functional before starting work or traveling with the machine.

1-8. Operating

- Always make sure that there are no obstructions or persons in your line of travel before starting the compactor in motion.
- Never climb on and off the machine while it is in motion.
- Always remain seated with the seat belt fastened when traveling, compacting or loading or unloading the machine.
- Use caution and be very observant when operating in close quarters and congested areas.
- Obey all traffic regulations when working on public roads and make sure machine is compatible with these regulations.
- Never carry passengers.
- Know and use the hand signals for particular jobs and who has the responsibility for signaling.
- Do not work close to edges or in the vicinity of overhanging banks or on grades that could cause the compactor to slide or roll over. Avoid any areas that may be a risk to machine stability.
- Avoid side hill travel. Always operate up and down the slope. Always keep the propulsion (travel control) lever in low speed range when climbing or descending hills or steep grades.
- Make sure there is sufficient clearance when crossing underpasses, bridges and tunnels or when passing under overhead power lines.
- Never allow anyone to stand in the articulation area of the machine when the engine is running.
- Always look in all directions before reversing the direction of travel.
- Always switch on the lighting system (if equipped) during poor visibility conditions and after dark.
- Do not attempt to control the compactor travel speed with the throttle control. Maintain engine speed at the full operating RPM.
- Do not run the engine in a closed building for an extended period of time. Exhaust fumes can kill.

1-9. Stopping

- Always park the machine in a safe area on solid and level ground. If this is not possible, always park at a right angle to the slope and block the drums.
- Do not leave the operator's platform with the engine running. Always move the travel lever to neutral position and apply the parking brake then turn the starter switch to OFF.
- Lock all lockable compartments.

- Park behind a safe barrier, use proper flags, and warning devices, especially when parking in areas of heavy traffic.

1-10. Maintenance

- In any performing any work concerning the operation, adjustment or modification of the machine or it's safety devices or any work related to maintenance, inspection or repair, always follow the start-up and shut-down procedures in the Operator's Manual and the Maintenance Manual.
- Ensure that the maintenance area is safe and secure.
- If the machine is shut down for maintenance or repair work it must be secured against inadvertent starting by removing the starter key and attaching a warning sign to the starter switch.
- The machine must be parked on stable and level ground with the drums blocked to prevent inadvertent movement.
- Immediately after the engine has stopped, the exhaust system, engine, radiator coolant, engine oil, hydraulic fluid and other lubricants and components will be very hot. Fluids can be under pressure, removing the radiator cap or draining oil or changing filters can cause serious burns. Wait until the machine has cooled down.
- Use care when attaching and securing lifting tackle to individual parts and large assemblies being removed or repositioned for repair purposes to avoid the risk of accident. Use lifting devices that are in perfect condition and of sufficient lifting capacity. Never stand under suspended loads.
- Always use the proper tools and workshop equipment in good condition when performing maintenance or repairs on the machine.
- Always use specially designed safety ladders and working platforms when working above floor level. Never use machine parts as a climbing aid.
- Keep all steps, handles, handrails, platforms and ladders free from mud, dirt, grease, ice or snow.
- Clean the machine, especially threaded connections of any traces of oil or fuel before carrying out any maintenance or repairs. Never use aggressive detergents. Use lint free cleaning rags.
- Examine all fuel, lubricant and hydraulic fluid lines and connectors for leaks, loose connections chafe marks or damage after cleaning.
- Repair or replace defective parts immediately.
- Whenever possible, avoid servicing or maintenance when the engine is running unless the drums are adequately blocked, the articulation lock bar is in the locked position and the parking brake is applied.



SAFETY

- Never fill the fuel tank with the engine running, while near an open flame or while smoking. Always clean up any spilled fuel.
- Ensure safe operation, optimum performance of the machine and its warranty by using only genuine SAKAI replacement parts.
- Use only the specified fluids and lubricants. Substitute only products known to be equivalent from reputable manufacturers.
- Disconnect the battery cables when working on the electrical system or when welding on the compactor.
- Be sure the battery area is well ventilated (clear of fumes) should it be necessary to connect a jumper cable or battery charger. Fumes can ignite from a spark and may explode.
- Be sure battery charger is OFF when making connections if charging is required.
- Use only original fuses with the specified rating. Switch off the machine immediately if trouble occurs in the electrical system.
- Work on the electrical system may only be carried out by a qualified electrician or by a specially trained person according to electrical engineering principles.
- Inspect the electrical equipment of the machine at regular intervals. Defects such as loose connections or burnt or scorched wires must be repaired or replaced immediately.
- Do not weld, flame cut or perform grinding on the machine unless expressly authorized, as there may be a risk of fire or explosion. Disconnect the battery when welding on the machine.
- Clean the machine and its surrounding from dust or other flammable substances and make sure the area is adequately ventilated before beginning welding, flame cutting or grinding operations.
- Inspect hydraulic hoses at regular intervals and immediately replace if they show signs of chafing, cracking, brittleness, deformation, blistering, fitting separation, leakage, corrosion or other damage which may affect their function or strength.
- Do not work on hydraulic system while the engine is running and the system is under pressure. The hydraulic system remains pressurized even after the engine has stopped.
- Do not disconnect hydraulic hoses or fittings until the pressure has been properly relieved.
- Wait until the systems and fluid have cooled down before disconnecting.
- Never use your hands to check for leaks when inspecting a hydraulic system. Use a piece of cardboard and always wear gloves and safety glasses.



- Get immediate medical attention if fluid has been injected under your skin. Fluid penetration from a pin hole leak can cause severe injury or death.
- Ensure that hydraulic lines and hoses are routed and fitted properly. Ensure that no connections are interchanged. All fittings, lengths and specifications of hoses must comply with the technical requirements.

- Observe all product safety regulations when handling fuel, oils, grease, engine coolant and other chemical substances. Be careful especially when these items are hot as there is a risk of burning or scalding.
- Operate internal combustion engines and fuel operated heating systems only in adequately ventilated premises. Before starting the engine in an enclosed area, make sure there is sufficient ventilation.



1-11. Transporting the Machine

- Use only suitable and approved trailers and haul vehicles and lifting equipment of sufficient capacity.
- Entrust to experienced personnel the fastening and lifting of loads and instructing of crane operators.
- Only experienced persons familiar with the operation of the machine may load and unload the machine.
- Use ramps or a loading dock when loading or unloading the machine. Ramps must be the proper strength, low angle and the proper height and width.
- Block the drums (front and rear) of the hauling vehicle when loading and unloading the compactor. Ensure that the haul vehicle is on level ground and approach the loading ramps squarely to make sure that the compactor does not slide off the edge of the ramp.
- Keep the deck clear of mud, oil, ice or snow or other materials that can make the deck slippery.
- Position the compactor on the trailer or transport vehicle centered from side to side, and apply the brake. Shut off the engine and lock all lockable compartments.
- Block the drums and lock the articulation lock bar. Chain the machine down properly using the appropriate tackle.
- Know the overall height of the compactor and hauling vehicle. Observe height and weight regulations and be sure you can pass safely at overhead obstructions.
- Obey all traffic regulations and be sure that the proper clearance flags, lights and warning signs including "Slow Moving Vehicle" emblem are displayed when traveling on public roads.
- Know the approximate stopping distance at any given speed.
- Drive Safely. Never turn corners at excessive speeds.

SPECIFICATIONS

1. SPECIFICATION DATA

1-1. SW880

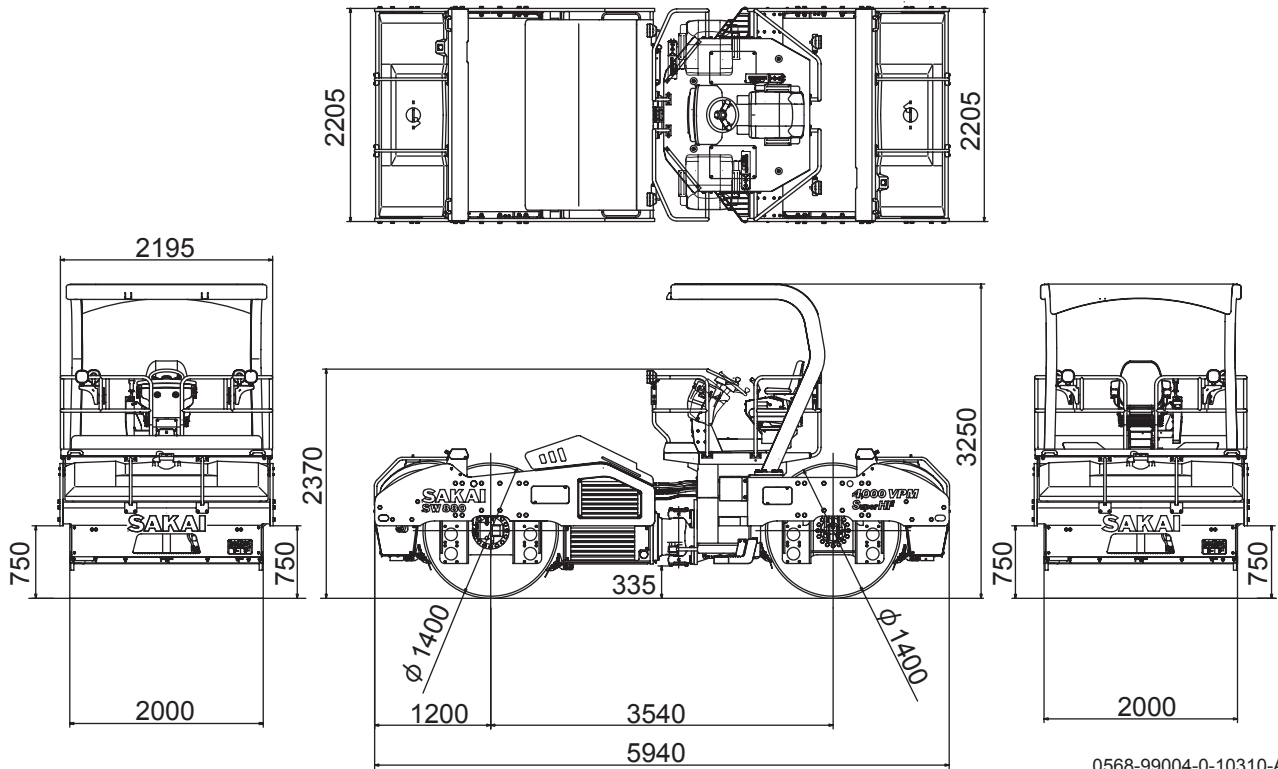

0568-99004-0-10310-A

Model		SW880	
Weight	Operating weight		13,410 kg (29,560 lbs.)
	Front axle		6,610 kg (14,570 lbs.)
	Rear axle		6,800 kg (14,990 lbs.)
Dimensions	Overall length		5,940 mm (234 in.)
	Overall width		2,205 mm (87 in.)
	Overall height		3,250 mm (128 in.)
	Wheelbase		3,540 mm (139 in.)
	Compaction width		2,000 mm (79 in.)
	Minimum height above ground		335 mm (13 in.)
	Curb clearance		750 mm (29.5 in.)
Drive speed	Forward/reverse		0 - 11 km/h (0 - 6.8 mph)
Vibration performance	Vibration frequency	Low amplitude	1 67 Hz (4,000 vpm)
			2 50 Hz (3,000 vpm)
			3 42 Hz (2,500 vpm)
		High amplitude	1 50 Hz (3,000 vpm)
			2 42 Hz (2,500 vpm)
			3 42 Hz (2,500 vpm)
	Centrifugal force	Low amplitude	1 160 kN (35,970 lbf.)
			2 90 kN (20,235 lbf.)
		High amplitude	1 177 kN (39,790 lbf.)
			2 123 kN (27,650 lbf.)
Amplitude	Low amplitude	0.33 mm (0.013 in.)	
	High amplitude	0.64 mm (0.025 in.)	
Minimum turning radius			6.4 m (252 in.)
Gradability*1			29 % (16.5°)

Engine	Name		DEUTZ TCD2012L04 2V diesel engine	
	Model		Water-cooled, 4-cycle, in-line, direct-injection, with turbocharger	
	Number of cylinders - Bore × Stroke		4-101 mm × 126 mm (4-3.976 in. × 4.961 in.)	
	Displacement		4,038 liters (246 cu.in.)	
	Performance	Rated rotating speed		2,400 min ⁻¹ (2,400 rpm)
		Rated output		98 kW (131 HP)
		Maximum torque		495 N·m (365 lbf·ft) at 1,600 min ⁻¹
		Fuel consumption rate		236 g/kW·h
	Fuel system	Fuel		Diesel oil
		Speed governor		Electronic all-speed type
	Lubrication system	Lubrication method		Forced circulation
		Filtration method		Full-flow
	Air cleaner		Dry type	
	Cooling system	Cooling fan		Exhaling type
		Radiator		Pressure type
	Charging generator		14 V	95 A
Starting motor		12 V	3.0 kW	
Battery		12 V	CCA 1000 × 1 unit (12 V)	
Power line	Propulsion pump control		Switching the direction of flow delivered from the variable pump	
	Final drive		Planetary gear	
Vibrating system	Type		Hydrostatic	
	Vibrator	Vibrating method	Eccentric shaft/variable type (two-stage variable type by forward and reverse rotation of eccentric shaft)	
	Installation location		Inside of front and rear drums	
Braking device	Service brake		Hydrostatic and mechanical type	
	Parking brake		Mechanical type	
Steering system	Steering control type		Articulated fully hydraulic type	
	Steering control angle		±36.7°	
	Oscillation angle		±6.5°	
Drums	Front drum (diameter × width) (vibration and driving)		1,400 mm × 2,000 mm (55 in. × 79 in.)	
	Rear drum (diameter × width) (vibration and driving)		1,400 mm × 2,000 mm (55 in. × 79 in.)	
Other	Ropes		Iron	
	Electrical components and instruments		1 set	

*1: The gradability is the calculated value. It may vary based on the ground surface conditions.

SPECIFICATIONS

1-2. SW990

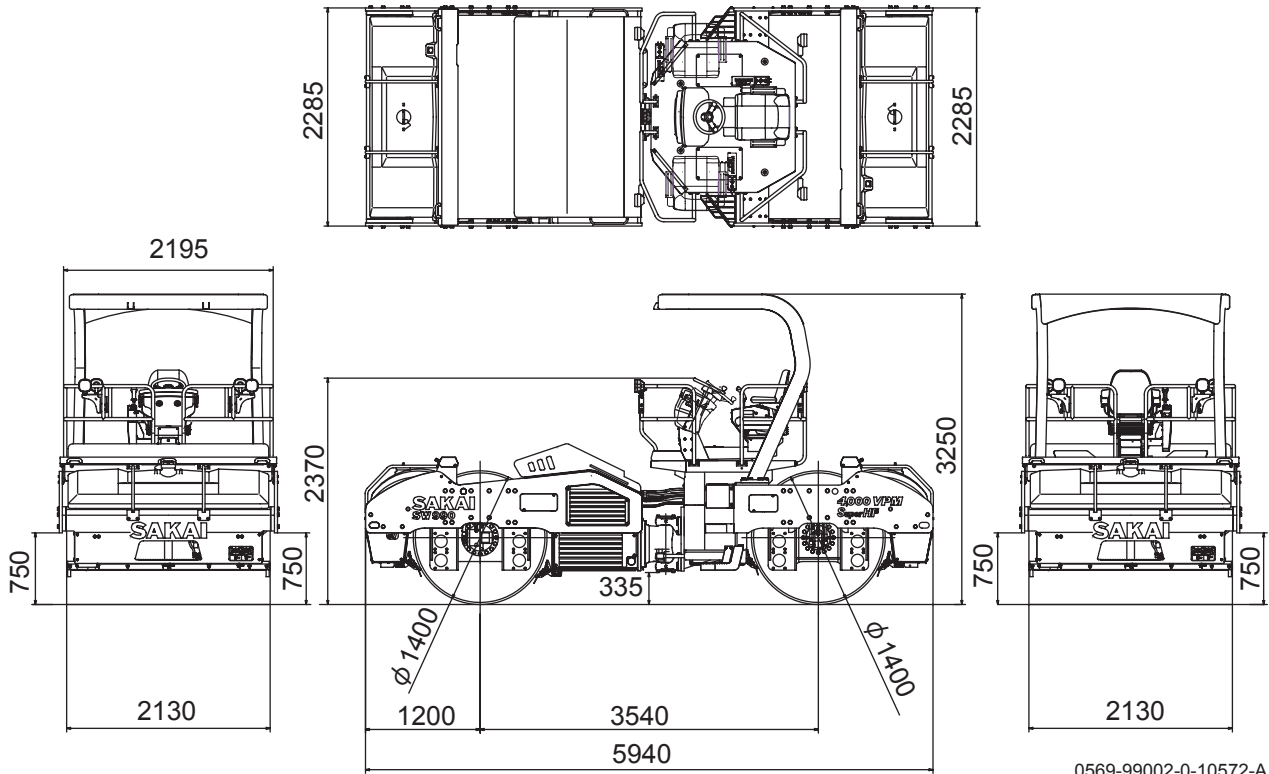

0569-99002-0-10572-A

Model		SW990	
Weight	Operating weight		13,970 kg (30,800 lbs.)
	Front axle		6,910 kg (15,235 lbs.)
	Rear axle		7,060 kg (15,565 lbs.)
Dimensions	Overall length		5,940 mm (234 in.)
	Overall width		2,285 mm (90 in.)
	Overall height		3,250 mm (128 in.)
	Wheelbase		3,540 mm (139 in.)
	Compaction width		2,130 mm (84 in.)
	Minimum height above ground		335 mm (13 in.)
	Curb clearance		750 mm (29.5 in.)
Drive speed	Forward/reverse		0 - 11 km/h (0 - 6.8 mph)
Vibration performance	Vibration frequency	Low amplitude	1 67 Hz (4,000 vpm)
			2 50 Hz (3,000 vpm)
			3 42 Hz (2,500 vpm)
		High amplitude	1 50 Hz (3,000 vpm)
			2 42 Hz (2,500 vpm)
			3 42 Hz (2,500 vpm)
	Centrifugal force	Low amplitude	1 173 kN (38,890 lbf.)
			2 98 kN (22,030 lbf.)
		High amplitude	1 185 kN (41,590 lbf.)
2 128 kN (28,775 lbf.)			
Amplitude	Low amplitude	0.33 mm (0.013 in.)	
	High amplitude	0.65 mm (0.026 in.)	
Minimum turning radius			6.5 m (256 in.)
Gradability*1			28 % (15.5°)

Engine	Name		DEUTZ TCD2012L06 2V diesel engine	
	Model		Water-cooled, 4-cycle, in-line, direct-injection, with turbocharger	
	Number of cylinders - Bore × Stroke		6-101 mm × 126 mm (6-3.976 in. × 4.961 in.)	
	Displacement		6,067 liters (370 cu.in.)	
	Performance	Rated rotating speed		2,400 min ⁻¹ (2,400 rpm)
		Rated output		124 kW (166 HP)
		Maximum torque		680 N·m (502 lbf·ft) at 1,600 min ⁻¹
		Fuel consumption rate		253 g/kW·h
	Fuel system	Fuel		Diesel oil
		Speed governor		Electronic all-speed type
	Lubrication system	Lubrication method		Forced circulation
		Filtration method		Full-flow
	Air cleaner		Dry type	
	Cooling system	Cooling fan		Exhaling type
		Radiator		Pressure type
Charging generator		14 V	95 A	
Starting motor		12 V	3.0 kW	
Battery		12 V	CCA 1000 × 1 unit (12 V)	
Power line	Propulsion pump control		Switching the direction of flow delivered from the variable pump	
	Final drive		Planetary gear	
Vibrating system	Type		Hydrostatic	
	Vibrator	Vibrating method	Eccentric shaft/variable type (two-stage variable type by forward and reverse rotation of eccentric shaft)	
	Installation location		Inside of front and rear drums	
Braking device	Service brake		Hydrostatic and mechanical type	
	Parking brake		Mechanical type	
Steering system	Steering control type		Articulated fully hydraulic type	
	Steering control angle		±36.7°	
	Oscillation angle		±6.5°	
Drums	Front drum (diameter × width) (vibration and driving)		1,400 mm × 2,130 mm (55 in. × 84 in.)	
	Rear drum (diameter × width) (vibration and driving)		1,400 mm × 2,130 mm (55 in. × 84 in.)	
Other	Ropes		Iron	
	Electrical components and instruments		1 set	

*1: The gradability is the calculated value. It may vary based on the ground surface conditions.

2. TABLE OF STANDARD VALUES

2-1. Engine

Classification	Item	Standard value		Remarks
		SW880	SW990	
Engine	Engine model	DEUTZ TCD2012L04 2V	DEUTZ TCD2012L06 2V	
	Rated output	98/2,400 kW/rpm (131/2,400 HP/rpm)	124/2,400 kW/rpm (166/2,400 HP/rpm)	No fan net
	Max. rpm under no load	2,520 ⁰ ₋₅₀ rpm		
	Min. rpm under no load	950 ± 25 rpm		
	Cylinder head tightening torque	30 N·m (22 lbf·ft)		
	Intake manifold tightening torque	25 N·m (18 lbf·ft)		
	Exhaust manifold tightening torque	30 N·m (22 lbf·ft)		
	Valve clearance (intake)	75°		Measure with special tool
	Valve clearance (exhaust)	120°		Measure with special tool
	Compression pressure	3 – 3.8 MPa (435 psi)		
	Injection pressure	16 MPa (2,625 psi)		
	Fuel consumption rate	236 g/kW·h (0.382 lb/HP·h)	253 g/kW·h (0.381 lb/HP·h)	When engine is at rated output
	Engine dry mass	391 kg (862 lbs.)	509 kg (1,122 lbs.)	

2-2. Drive

Classification	Item		Standard value	Remarks
Drive	Travel speed	Forward	0 – 11 km/h (0 – 6.8 mph)	
		Reverse	0 – 11 km/h (0 – 6.8 mph)	
	Operate speed		0 – 4.5 km/h (0 – 2.8 mph)	Vibration Frequency: 2,500 vpm
			0 – 5.5 km/h (0 – 3.4 mph)	Vibration Frequency: 3,000 vpm
			0 – 7.2 km/h (0 – 4.5 mph)	Vibration Frequency: 4,000 vpm

2-3. Hydraulic System

Classification	Item	Standard value	Remarks	
Hydraulic system	Propulsion circuit	Relief valve pressure setting	40.2 ± 1.0 MPa (5,829 ± 145 psi)	Differential pressure
		Pressure override valve pressure setting	37.3 ± 1.0 MPa (5,409 ± 145 psi)	Differential pressure
		Charge relief pressure setting	2.5 ± 0.2 MPa (362 ± 29 psi)	
		Propulsion motor drainage (front drum)	Less than 10 L/min (Less than 2.6 gal./min)	Allowable maximum value (at maximum rotation)
		Propulsion motor drainage (rear drum)	Less than 10 L/min (Less than 2.6 gal./min)	Allowable maximum value (at maximum rotation)
		Front motor brake release pressure	1.5 – 3.9 MPa (218 – 566 psi)	
		Rear motor brake release pressure	1.5 – 3.9 MPa (218 – 566 psi)	
	Vibration circuit	Relief valve pressure setting	31.5 ± 1.0 MPa (4,568 ± 145 psi)	Differential pressure
		Charge relief pressure setting	2.5 ± 0.2 (362 ± 29 psi)	
		Port relief valve pressure setting	34.0 ± 1.0 MPa (4,930 ± 145 psi)	
		Vibrator motor drainage	Less than 6.4 L/min (Less than 1.7 gal./min)	Allowable maximum value (at maximum rotation)
		Steering circuit (Orbitrol relief pressure setting + charge relief pressure setting)	17.5 ± 1.0 MPa (2,451 ± 145 psi)	

2-4. Steering

Classification	Item	Standard value	Remarks
Steering	Play in steering wheel	5 – 10 mm (0.2 – 0.4 in.)	Steering wheel circumference
		Less than 0.5 mm (less than 0.02 in.)	Steering column shaft direction

SPECIFICATIONS

2-5. Brakes

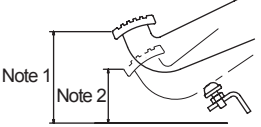
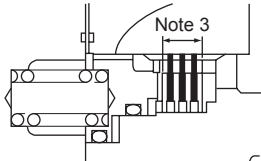
Classification	Item	Standard value	Remarks
Brake	Clearance between pedal brake and floorboard (when released)	137 mm (5.4 in.) Note 1: See dimensions.	 SW880-02001
	Clearance between pedal brake and floorboard (when pressed down)	82 mm (3.2 in.) Note 2: See dimensions.	
	Disc assembly (7 discs) dimension (wear limit) for brake replacement	18.5 mm (0.73 in.) Note 3: See dimensions. Standard dimension: 19.1 mm (0.75 in.)	 SW880-02002

2-6. Water System

Classification	Item	Standard value	Remarks
Water system	Water spray pump discharge pressure (front drum) [with discharge rate at 4.5 L/min (1.2 gal./min)]	0.17 ± 0.1 MPa (24.7 ± 14.5 psi)	
	Water spray pump discharge pressure (rear drum) [with discharge rate at 4.5 L/min (1.2 gal./min)]	0.17 ± 0.1 MPa (24.7 ± 14.5 psi)	

2-7. Oil and Grease Capacity

Classification	Item	Standard value		Remarks
		SW880	SW990	
Oil/grease capacity	Engine oil	11 L (2.9 gal.)	15.5 L (4.1 gal.)	
	Coolant	17 L (4.5 gal.)	19 L (5.0 gal.)	
	Wheel motor reduction gear case gear oil (front)	3.9 L (1.0 gal.)		
	Wheel motor reduction gear case gear oil (rear)	3.9 L (1.0 gal.)		
	Vibrator case gear oil (front/rear)	22 L × 2 (5.8 gal. × 2)		
	Hydraulic fluid tank oil	55 L (15 gal.)		
	Fuel tank	315 L (83 gal.)		
	Sprinkler tank	600 L × 2 (159 gal. × 2)		

3. FUEL AND LUBRICANTS SPECIFICATION

3-1. Rating

Lubricant	Service classification	Ambient temp. and applicable viscosity rating			Applicable Standards
		-15 – 30°C (5 – 86°F) Cold	0 – 40°C (32 – 104°F) Moderate	15 – 55°C (59 – 131°F) Tropical	
Engine oil	API grade CH-4	SAE 10W-30	SAE 30	SAE 40	MIL-L-2104D
Gear oil	API grade GL4	SAE 80W-90	SAE 90	SAE 140	MIL-L-2105
Hydraulic oil	Wear resistant	ISO-VG32 over VI 140	ISO-VG46 over VI 140	ISO-VG68 over VI 110	ISO-3448
Grease	Lithium type extreme pressure				NLGI-2
Fuel	Diesel oil				ASTM D975-2D

3-2. Recommended Lubricants

Lubricant Oil company	Engine oil API CH-4	Gear oil API GL-4	Hydraulic oil VG 46	Grease (NLGI-II)
CALTEX	DELO 400 oil	Universal Thuban 90	Rando Oil HD 46	Martifack EP 2
BP	BP Vanellus MG	BP Gear Oil EP 90	BP Energol HLP 46	BP Energrease LP-EP 2
ESSO	Esso Lube XD-3 extra	Esso Gear Oil GP 90	Nuto H 46	Beacon EP 2
MOBIL	Mobil Delvac 1330 super	Mobil Pegasus Gear oil 90	Nuto Oil 25	Beacon EP 25
SHELL	Shell Rotella T	Shell Spirax 90 EP	Shell Tellus Oil 46	Shell Alvania EP Grease 2
CASTROL	Castrol Elexion	Castrol Hypoy 90	Hyspin AWS 46	Spherrol ELP 2

4. TIGHTENING TORQUE CHART

N·m	(lbf·ft)
-----	----------

	Nominal Dia.	Pitch	Strength Classification							
			6.8		8.8		10.9		12.9	
Metric coarse screw	5	0.8	4.9	(3.6)	5.9	(4.4)	7.8	(5.8)	7.8	(5.8)
	6	1.0	7.8	(5.8)	9.8	(7.2)	13	(9.6)	13	(9.6)
	8	1.25	17	(13)	23	(17)	31	(23)	31	(23)
	10	1.5	39	(29)	49	(36)	59	(44)	59	(44)
	12	1.75	69	(51)	78	(58)	108	(80)	108	(80)
	14	2.0	98	(72)	127	(94)	167	(123)	167	(123)
	16	2.0	157	(116)	196	(145)	265	(195)	265	(195)
	18	2.5	196	(145)	245	(181)	343	(253)	343	(253)
	20	2.5	294	(217)	392	(289)	539	(398)	539	(398)
	22	2.5	441	(325)	539	(398)	686	(506)	686	(506)
	24	3.0	539	(398)	637	(470)	883	(651)	883	(651)
	27	3.0	785	(579)	981	(724)	1324	(977)	1324	(977)
	30	3.5	1079	(796)	1324	(977)	1765	(1302)	1765	(1302)
Metric fine screw	10	1.25	39	(29)	49	(36)	69	(51)	69	(51)
	12	1.25	69	(51)	88	(65)	118	(87)	118	(87)
	14	1.5	108	(80)	137	(101)	186	(137)	186	(137)
	16	1.5	167	(123)	206	(152)	284	(209)	284	(209)
	18	1.5	245	(181)	294	(217)	392	(289)	392	(289)
	20	1.5	343	(253)	441	(325)	588	(434)	588	(434)
	22	1.5	490	(361)	588	(434)	785	(579)	785	(579)
	24	2.0	588	(434)	735	(542)	981	(724)	981	(724)
	27	2.0	834	(615)	1030	(760)	1422	(1049)	1422	(1049)
	30	2.0	1177	(868)	1422	(1049)	1961	(1446)	1961	(1446)

ENGINE AND CONTROLS

1. ENGINE

1-1. Engine Mount

1-1-1. Engine mount (SW880)

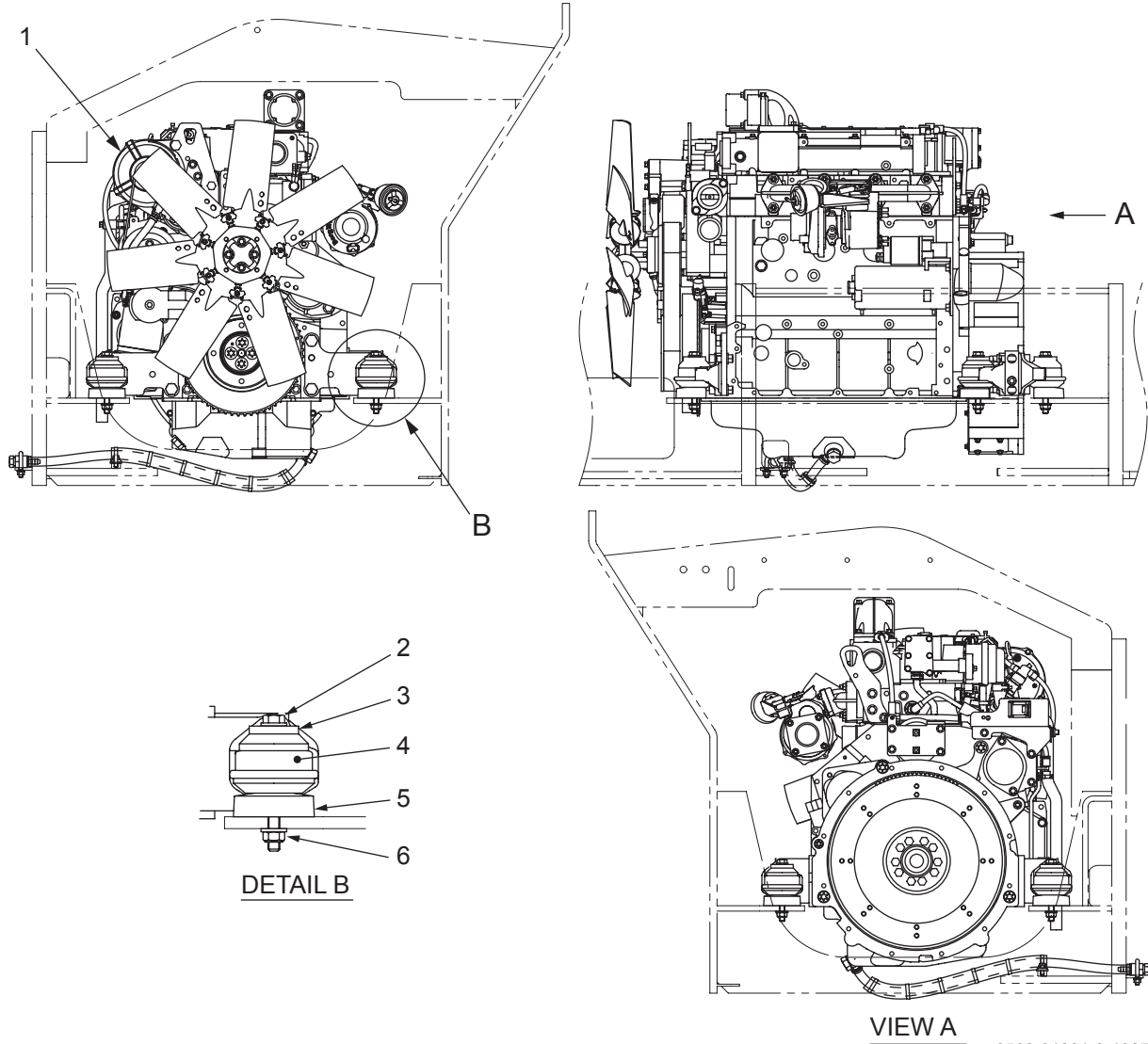

0568-01801-0-10073-B

- (1) Engine
- (2) Nut (M12)
- (3) Washer
- (4) Damper
- (5) Base



- (6) Bolt M12×130 : 108 N·m (80 lbf-ft)

- Engine dry weight: 391 kg (862 lbs.)
- Engine oil capacity: 11 L (2.9 gal.)

1-1-2. Engine mount (SW990)

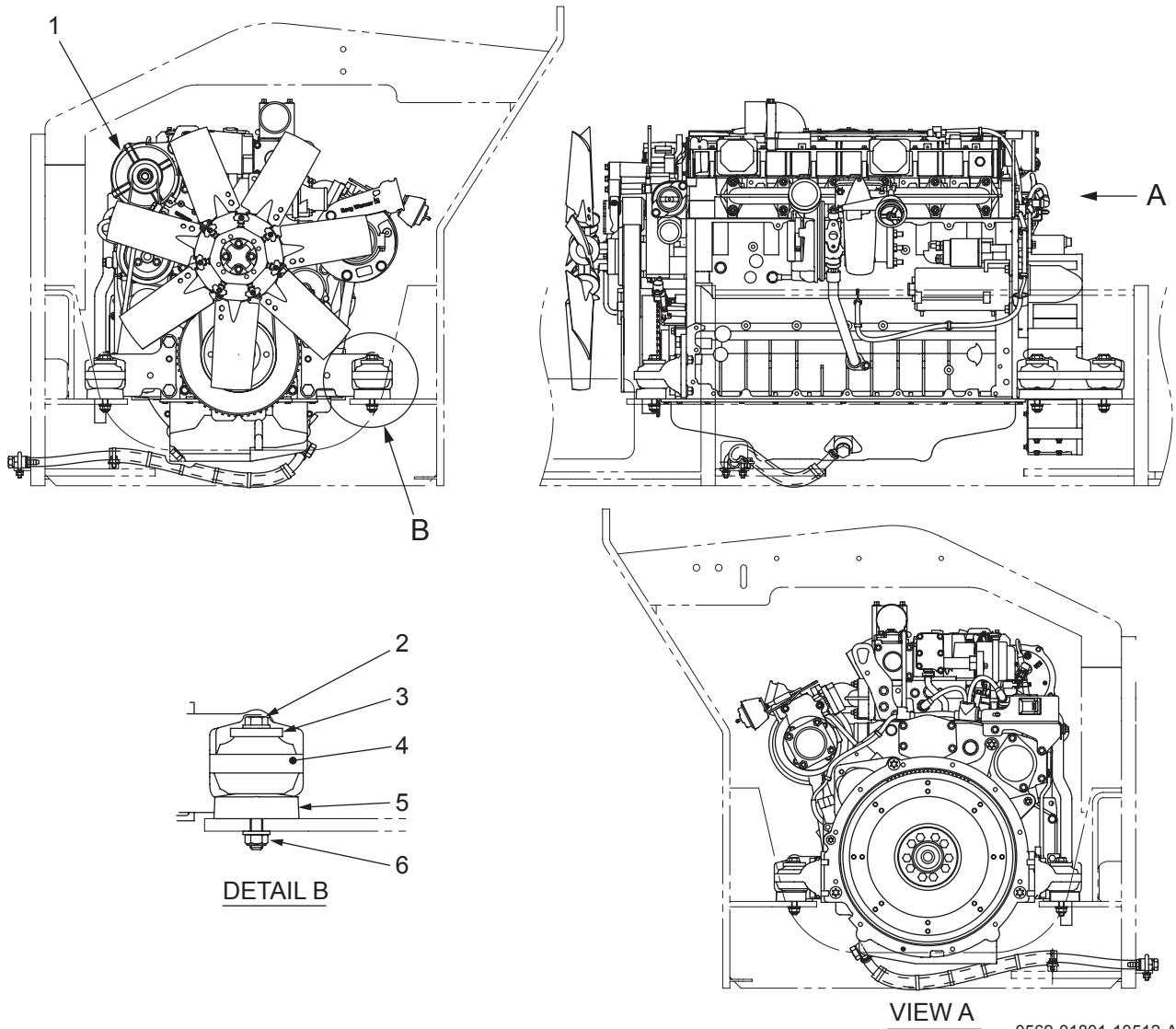

0569-01801-10512-A

- (1) Engine
- (2) Nut (M12)
- (3) Washer
- (4) Damper
- (5) Base



- (6) Bolt M12×130 : 108 N·m (80 lbf·ft)

- Engine dry weight: 509 kg (1,122 lbs.)
- Engine oil capacity: 15.5 L (4.1 gal.)

1-2. Engine Exterior

1-2-1. Engine exterior (SW880)

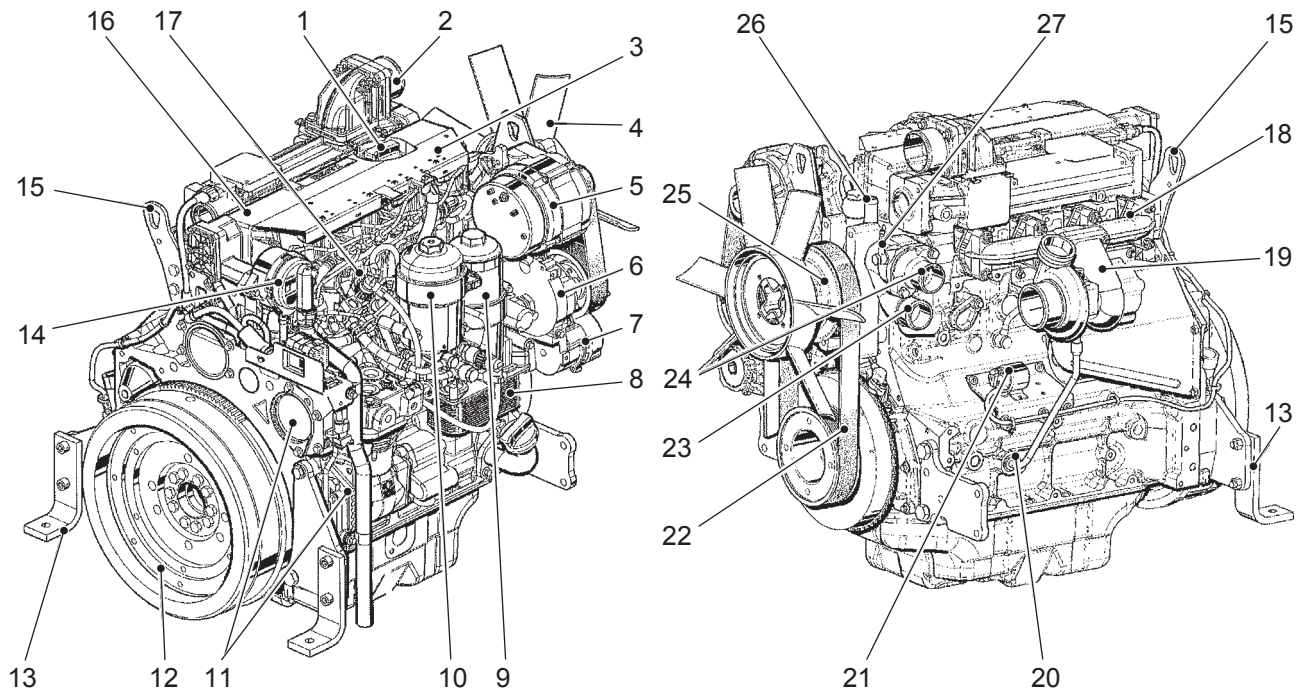

SW880-03001

* The actual equipment may differ from that shown above.

- | | |
|---|--|
| (1) Lubricating of filling | (14) Crankcase ventilation valve |
| (2) Combustion air inlet | (15) Transport device |
| (3) Cover for cable harness mount | (16) Cylinder head cover |
| (4) Fan | (17) Control block FCU (Fuel Control Unit) |
| (5) Generator | (18) Exhaust manifold line |
| (6) Coolant pump | (19) Turbocharger |
| (7) Tension pulley | (20) Lubricating oil return line from exhaust turbocharger |
| (8) Lube oil cooler | (21) Relay (starter) |
| (9) Lubricating oil filter | (22) V-rib belt |
| (10) Fuel filter | (23) Coolant inlet |
| (11) Hydraulic pump or compressor mounting (optional) | (24) Coolant outlet |
| (12) Flywheel | (25) Fan mounting |
| (13) Transport bracket (only for transport) | (26) Compensation line connection to tank |
| | (27) Ventilation line connection |

1-2-2. Engine exterior (SW990)

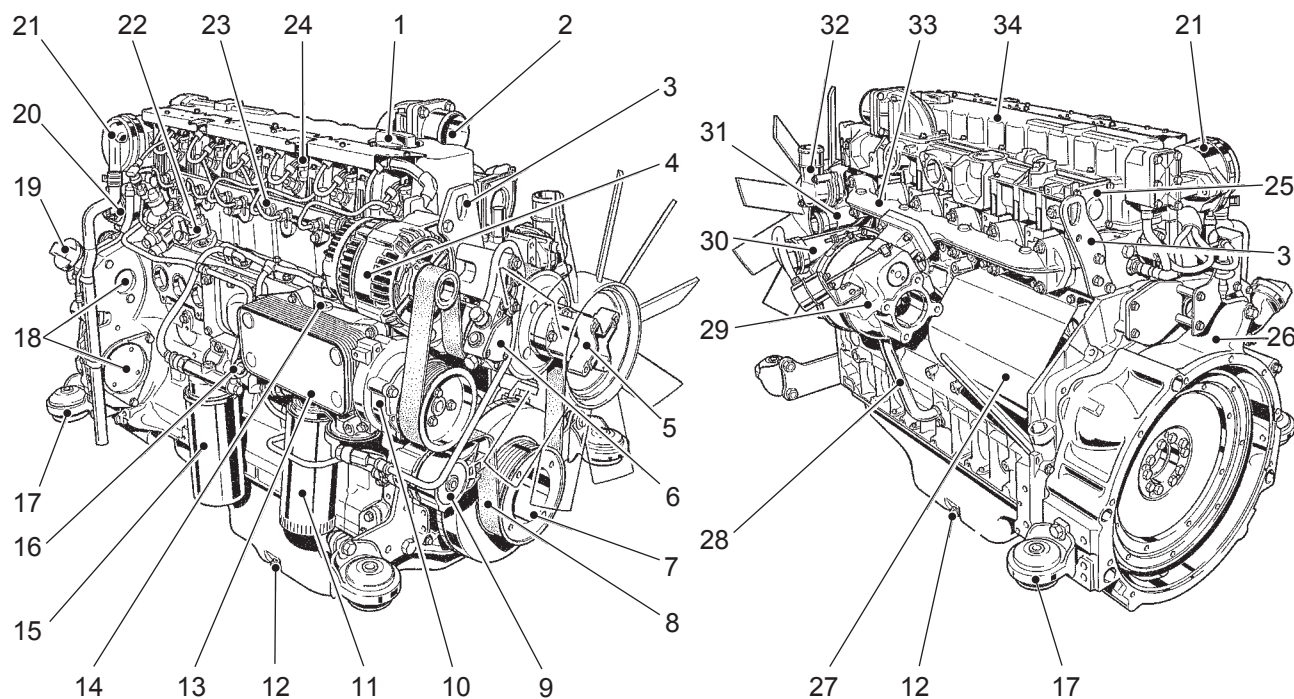

SW990-03001

* The actual equipment may differ from that shown above.

- | | |
|---|--|
| (1) Lubricating oil filling | (18) Hydraulic pump or air compressor mounting (optional) |
| (2) Combustion air inlet | (19) Lubricating oil filling (optional) |
| (3) Transport device | (20) Central plug (for engine control) |
| (4) Generator | (21) Crankcase ventilation valve |
| (5) Fan hub | (22) High-pressure pump |
| (6) Fuel supply pump | (23) Rail |
| (7) Belt pulley with torsional vibration damper on crankshaft | (24) Injector |
| (8) V-rib belt | (25) Charge air line |
| (9) Tension pulley | (26) Gear connection (SAE housing) |
| (10) Coolant pump | (27) Starter cover |
| (11) Lube oil replacement filter | (28) Lubricating oil return line from exhaust turbocharger |
| (12) Lubricating oil drain plug | (29) Turbocharger |
| (13) Lube oil cooler | (30) Charge air connection to charge air cooler |
| (14) Cab heating supply flow line | (31) Coolant inlet |
| (15) Exchangeable fuel filter | (32) Coolant outlet |
| (16) Lubricating oil dipstick | (33) Exhaust manifold line |
| (17) Engine mounting | (34) Cylinder head cover |

1-3. Fuel System

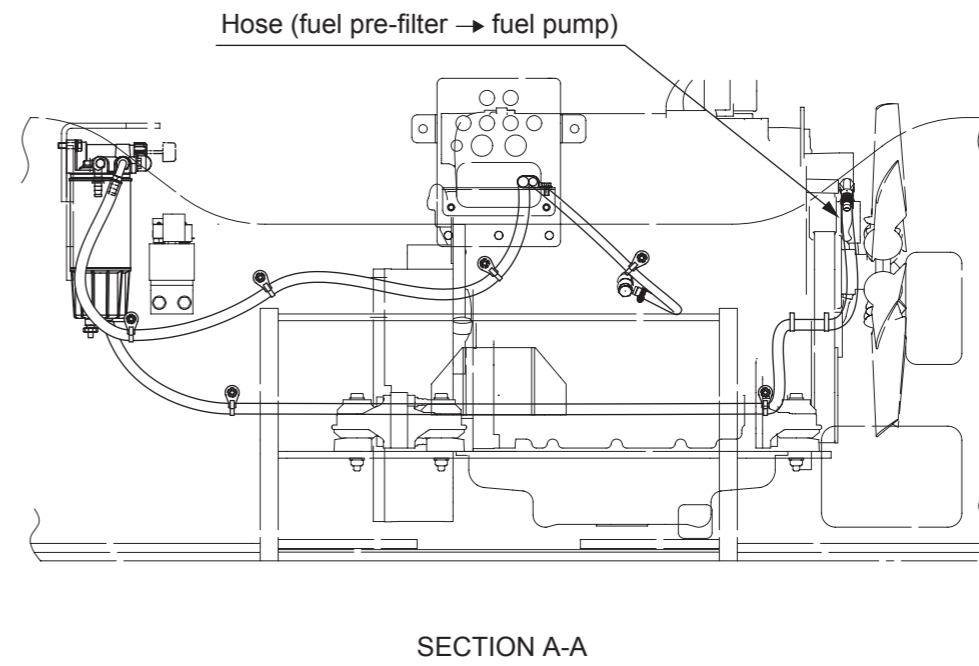
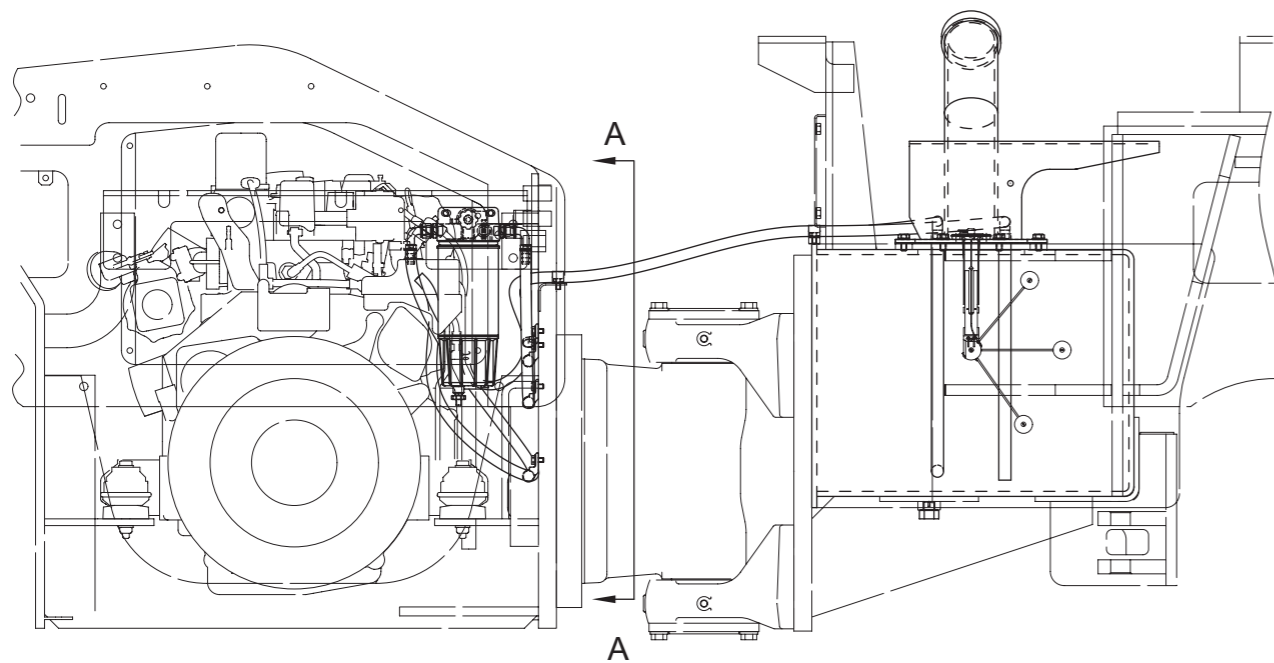
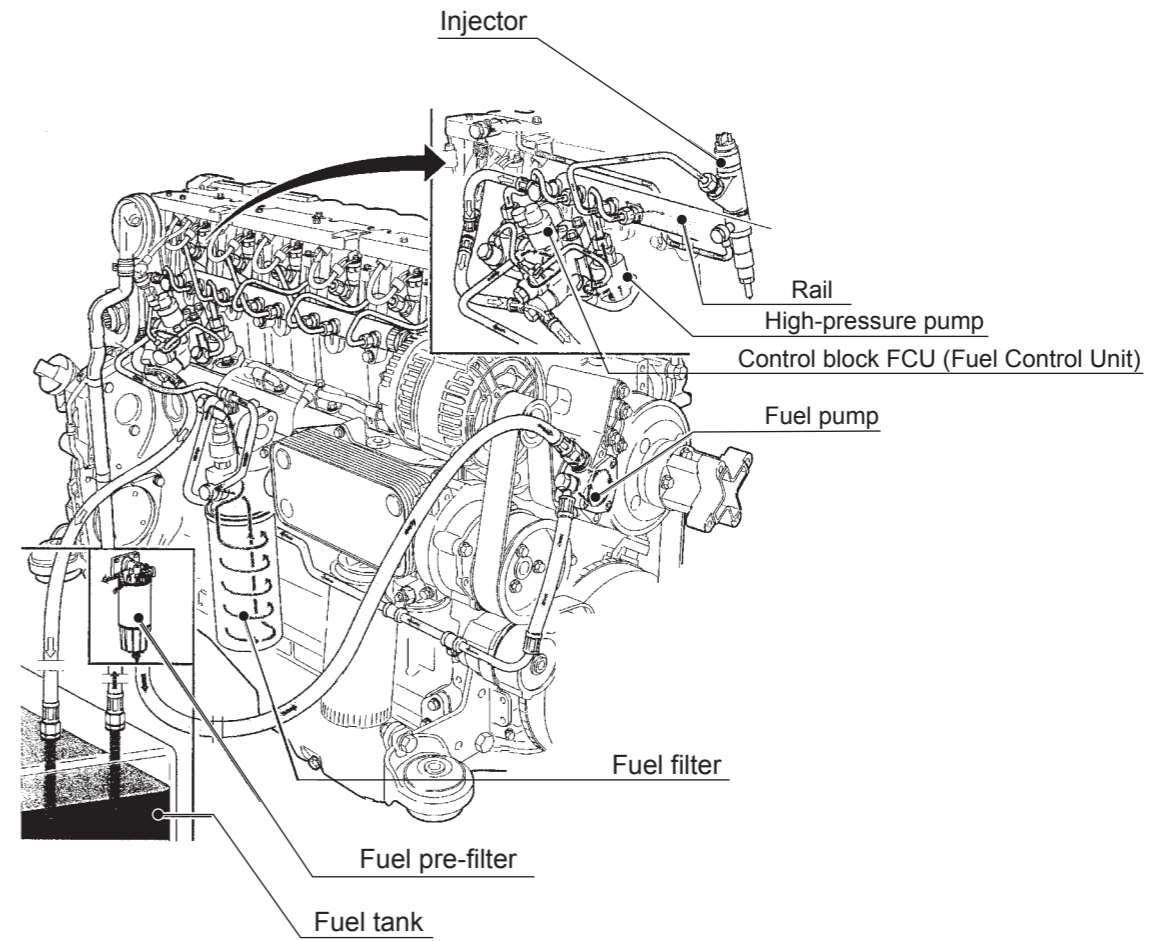
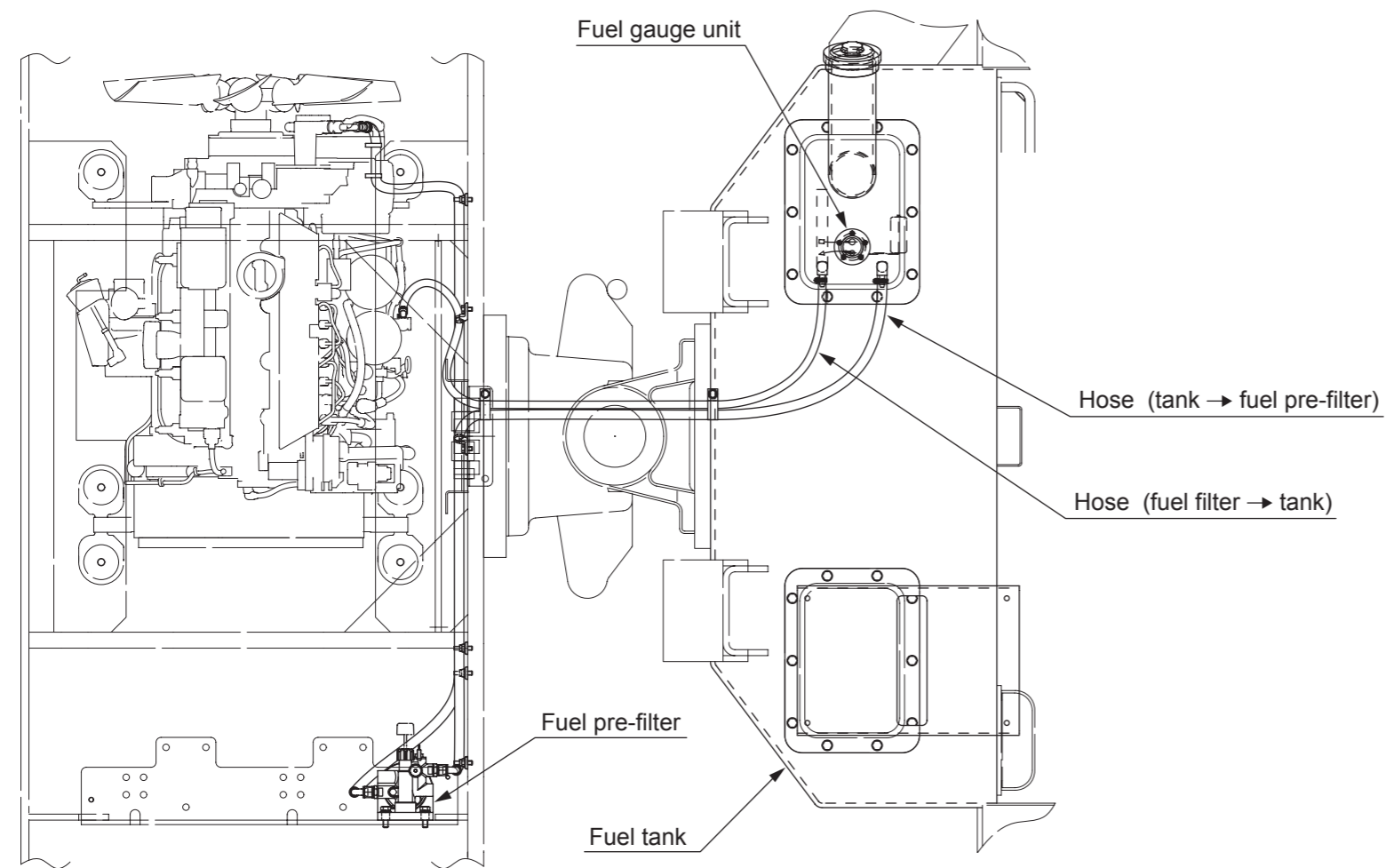

1-4. Cooling System

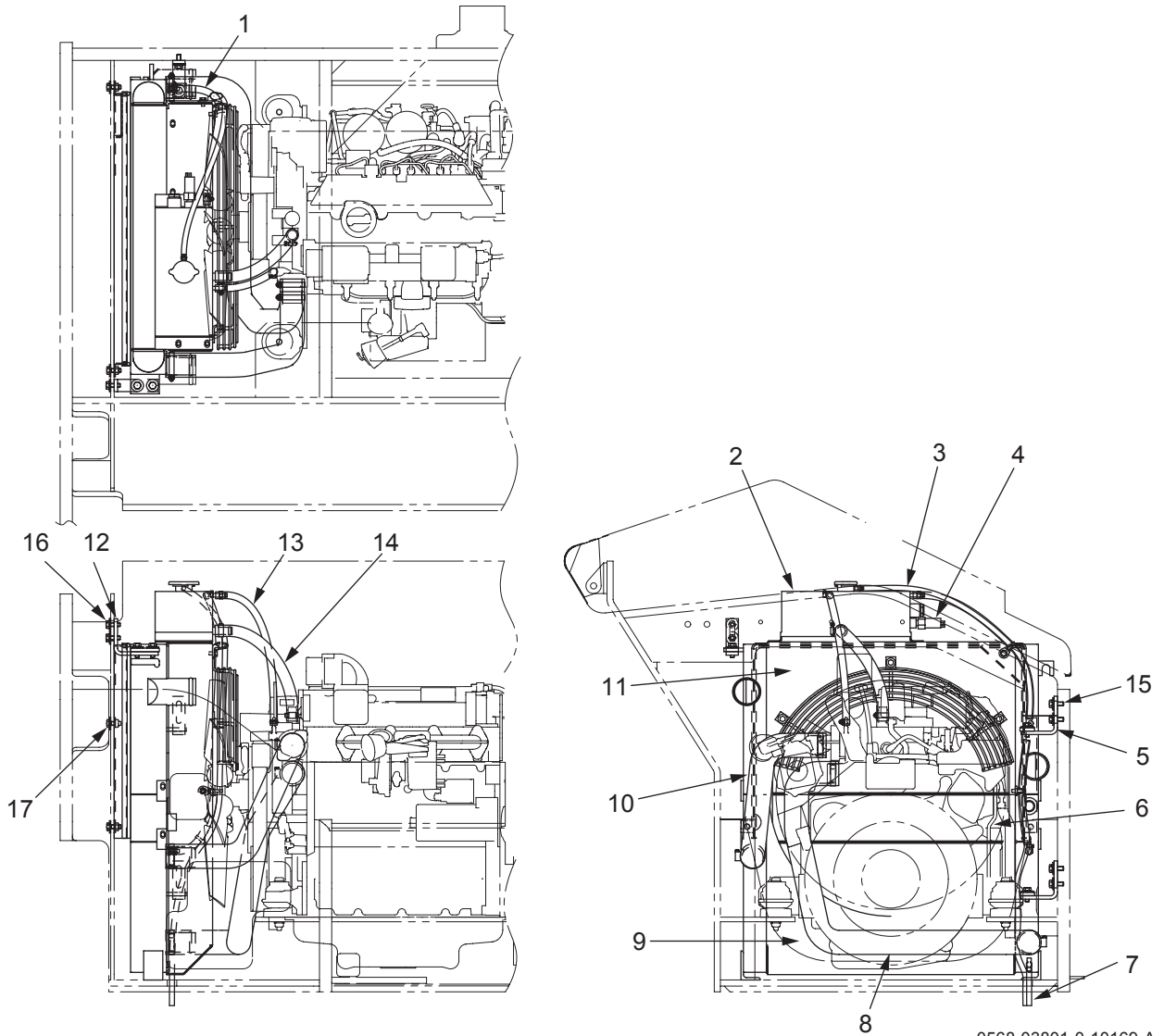

0568-03801-0-10169-A

- (1) Breather hose (radiator)
- (2) Surge tank
- (3) Hose (for overflow)
- (4) Coolant temperature sensor
- (5) Bracket
- (6) Oil cooler
- (7) Drain
- (8) Hose (radiator → engine)
- (9) Radiator
- (10) Hose (engine → radiator)

- (11) Charge air cooler
- (12) Bracket
- (13) Breather hose (engine)
- (14) Surge hose



- (15) Bolt M10×30 : 49 N·m (36 lbf·ft)
- (16) Bolt M10×30 : 49 N·m (36 lbf·ft)
- (17) Bolt M10×30 : 49 N·m (36 lbf·ft)

2. CONTROL SYSTEM

2-1. Forward-reverse Control

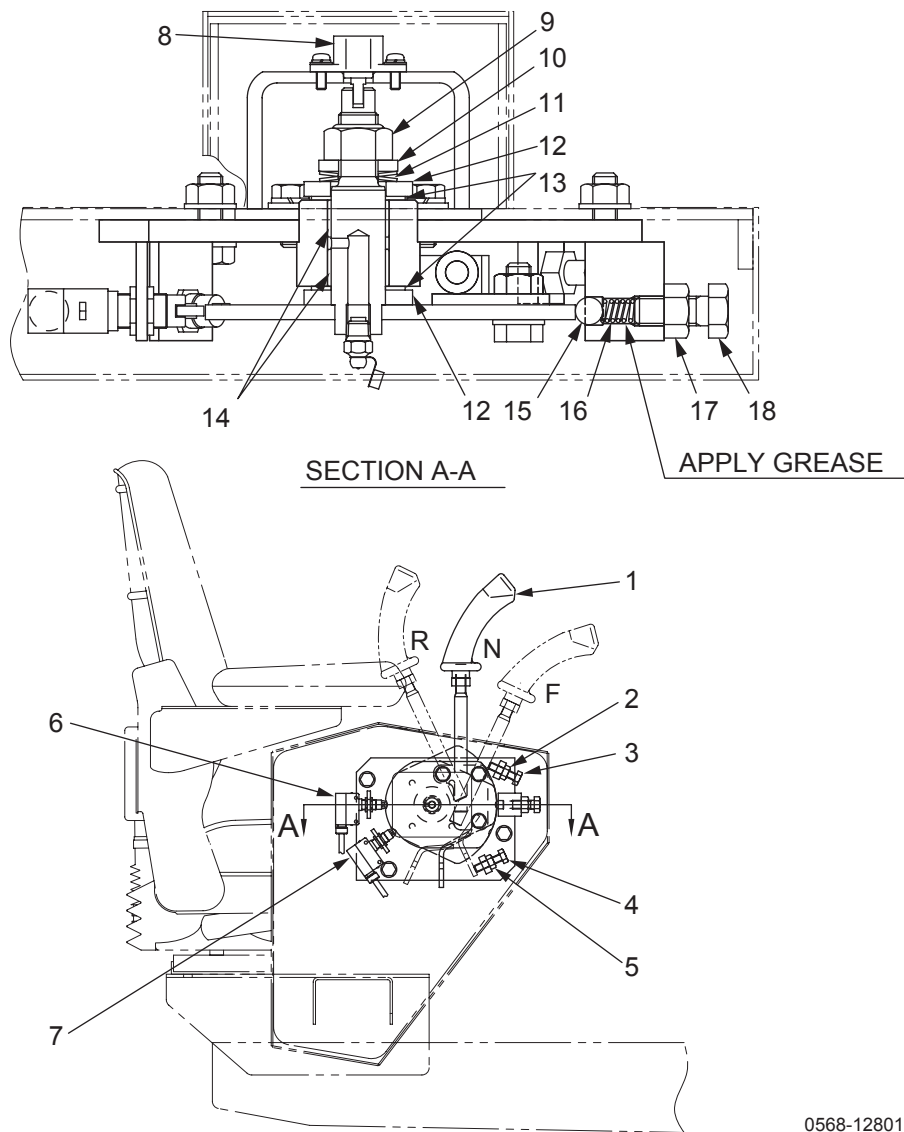

- | | |
|----------------------------------|---------------------|
| (1) Forward-reverse lever | (10) Washer |
| (2) Locknut | (11) Disc spring |
| (3) Stopper bolt (forward) | (12) Washer |
| (4) Stopper bolt (reverse) | (13) Oilless washer |
| (5) Locknut | (14) Bushing |
| (6) Forward-reverse lever switch | (15) Steel ball |
| (7) Backup buzzer switch | (16) Spring |
| (8) Potentiometer | (17) Locknut |
| (9) U-nut | (18) Bolt |

0568-12801-0-20066-B

2-2. Adjustment of Forward-reverse Lever Potentiometer

2-2-1. Adjustment

- When replacing the forward-reverse lever potentiometer, make an adjustment in accordance with the procedure described below.
- ① Adjust the neutral notch with the bolt (18) so that the neutral position of the forward-reverse lever (1) will always be the same. Then, tighten the nut (9) to stabilize the movement of the forward-reverse lever. [Adjust the lever operating force at the middle of the grip to 40 ± 10 N (9.0 ± 2.2 lbf)].
 - ② Apply grease to the shaft of the potentiometer.
 - ③ Insert the potentiometer into the slit of the forward-reverse lever shaft with its rotational shaft positioned in the middle ($\pm 60^\circ$) of the movable range ($120^\circ \pm 5^\circ$). Then, fix the potentiometer.
 - ④ Install the forward-reverse lever switch (6) in the position where it is turned on when the forward-reverse lever is moved forward or backward by $2.5^\circ \pm 0.5^\circ$.
 - ⑤ Install the back buzzer switch (7) in the position where it is turned on when the forward-reverse lever is moved backward by $3^{+1.0}_0$.
 - ⑥ Adjust the forward-reverse lever with the stopper bolts (3) and (4) so that its maximum tilt angles in the forward and reverse directions are $25^{+2.0}_0$.

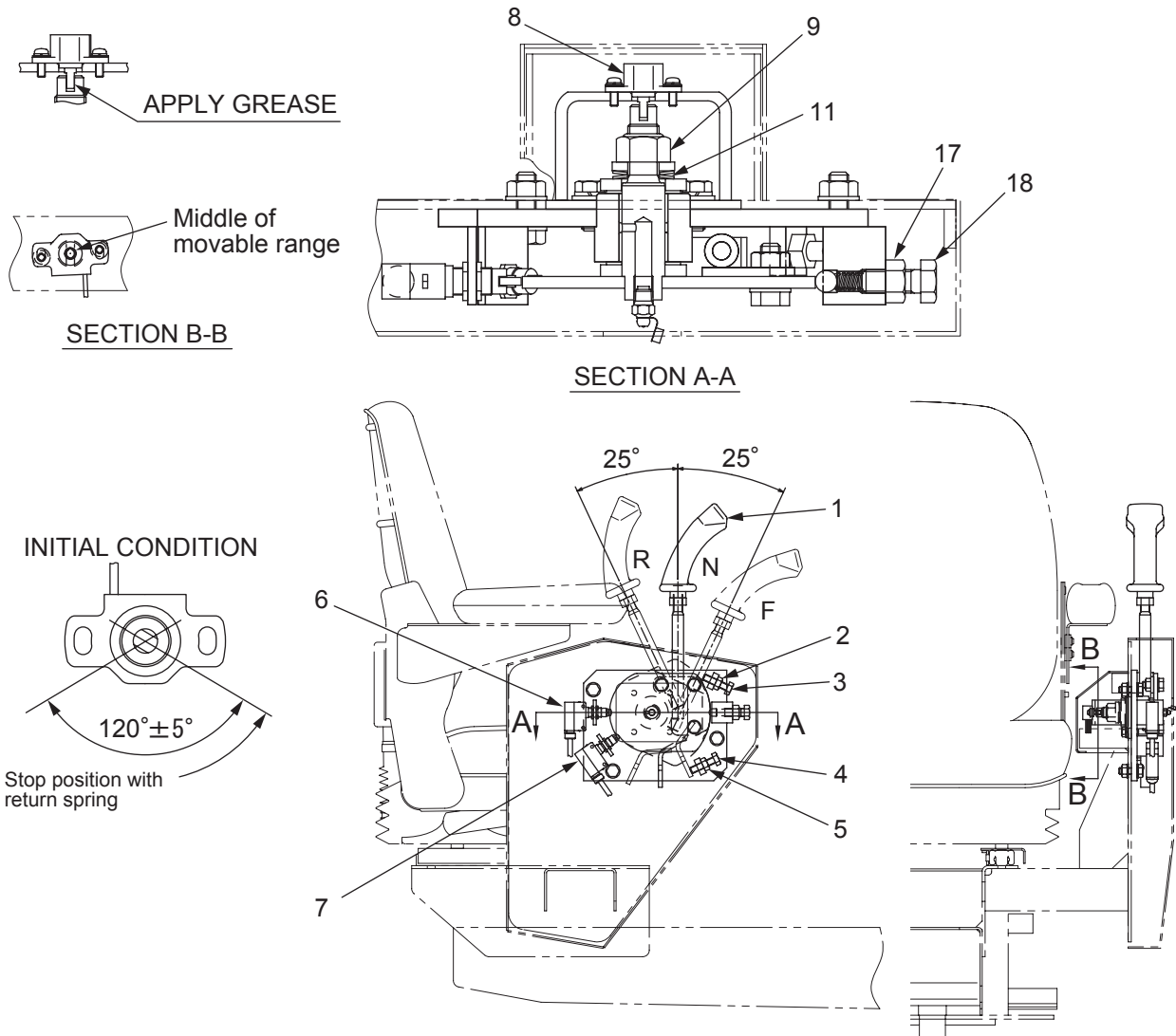

SW880-03002

3. PUMP MOUNT

3-1. Pump Mount

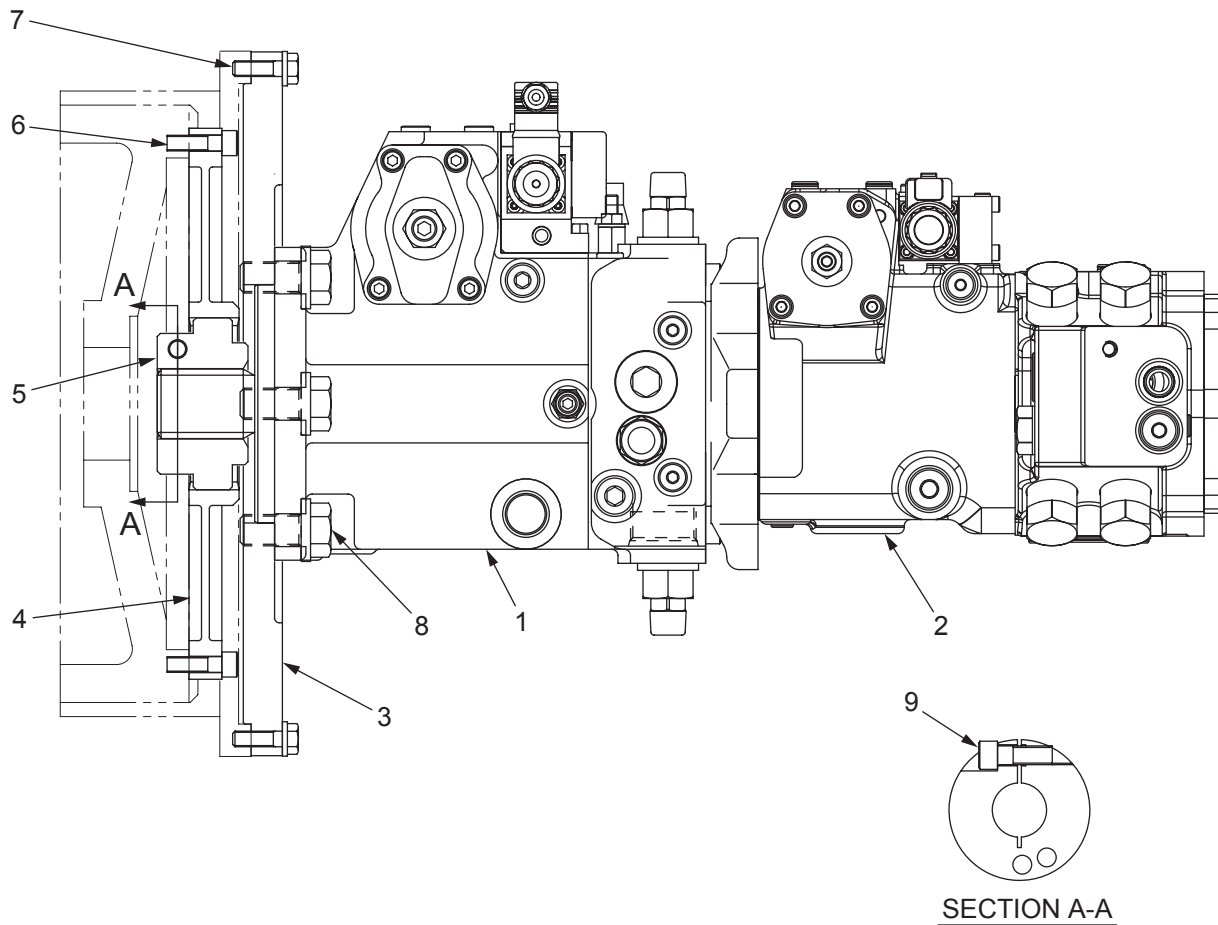

- (1) Propulsion pump
- (2) Vibrator pump
- (3) Housing
- (4) Flange
- (5) Hub



- (6) Hexagon socket head bolt M10×35 : 49 N·m (36 lbf-ft)
- (7) Bolt M10×35 : 60 N·m (44 lbf-ft)
- (8) Bolt M20×45 : 539 N·m (398 lbf-ft)
- (9) Hexagon socket head bolt M12×35 : 86 N·m (63 lbf-ft)

0568-36801-0-10168-B

3-2. Installation of Pump

- When the pump assembly has been removed from the engine for repair or replacement, reinstall it in accordance with the following procedure.

- ① Apply an ample amount of molybdenum grease to the spline surface of the pump (1) and hub (5).
- ② Attach the hub (5) to the pump (1) aligning it with the end surface of the shaft.
- ③ Tighten the hexagon socket head bolt (9) to secure the hub.

 (9) M12×35 : 86 N·m (63 lbf·ft)

- ④ Install the housing (3) on the pump (1) and secure it with the six bolts (8) and washers.

 (8) M20×45 : 539 N·m (398 lbf·ft)

- ⑤ Install the flange (4) on the engine flywheel and tighten the eight hexagon socket head bolts (6) to secure it.

 (6) M10×35 : 49 N·m (36 lbf·ft)

- ⑥ Ensure the engagement of the flange (4) with the hub (5) and install the pump subassembly in the engine.

- ⑦ Tighten the twelve bolts (7) on which the washers are put to secure the pump subassembly.

 (7) M10×35 : 60 N·m (44 lbf·ft)

(NOTICE)

- Do not reuse the bolts (6) because they are applied with thread lock. Replace with new bolts.

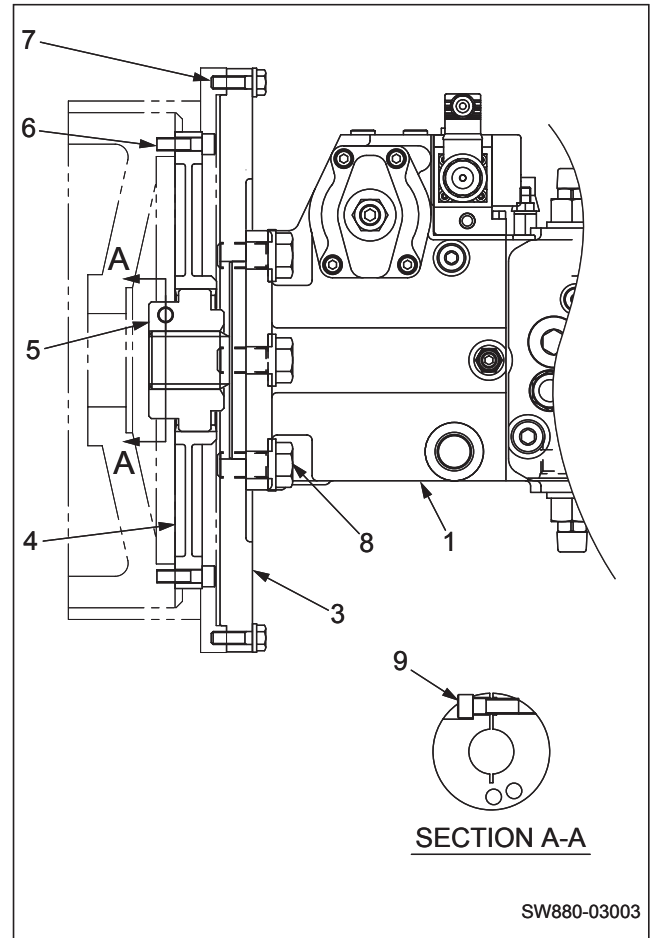

HYDRAULIC SYSTEMS

1. SYSTEM CIRCUIT DIAGRAM

1-1. Graphic Symbols for Hydraulic Circuits

Basic Symbols

DESCRIPTION	SYMBOL
Lines:	
Main Working	
Pilot Control	
Drain or Bleed	
Lines, joining	
Not Connected	
Component Outline	
Arrow indicates direction of flow.	
Line with fixed restriction (orifice).	
Test port, pressure measurement.	
Temperature measurement gauge	
Pressure measurement gauge	
Reservoir (vented)	
Filter or Strainer	
Heat exchanger, lines indicate flow of coolant.	
Quick Disconnect: Connected with mechanically opened checks. Disconnected.	
Sloping arrow through a symbol at 45° indicates that a component can be adjusted or varied.	

Pump, Motors and Cylinders

DESCRIPTION	SYMBOL
Hydraulic Pumps:	
Fixed Displacement	
Unidirectional	
Bidirectional	
Variable Displacement	
Unidirectional	
Bidirectional	
Variable Displacement Pressure Compensated Unidirectional	
Hydraulic Motor:	
Unidirectional	
Bidirectional	
Double acting hydraulic cylinder	
Differential cylinder	
Electric Motor	

Valves

DESCRIPTION	SYMBOL
Check Valve	
Manual Shut Off (On-Off)	
Pressure Relief	
Flow control, adjustable	
Valve Symbols: The basic valve symbol one or more squares with lines representing flow paths and flow conditions between ports.	
Multiple squares indicate a valve with as many distinct positions there are squares providing various flow path options for the fluid. The multiple square moves to represent how flow paths change when the valving element is shifted within the component.	
Valves with infinite positioning between certain limits are symbolized with lines parallel to the squares.	

Methods of Operation

DESCRIPTION	SYMBOL
Spring	
Manual	
Pressure Compensated	
Reversing Motor	
Pilot Pressure: Internal Supply	
Remote Supply	
Solenoid: Single winding	
Two windings operating in opposite directions.	
Pilot directional valve is actuated by the solenoid.	

1-2. Hydraulic Circuit Diagram

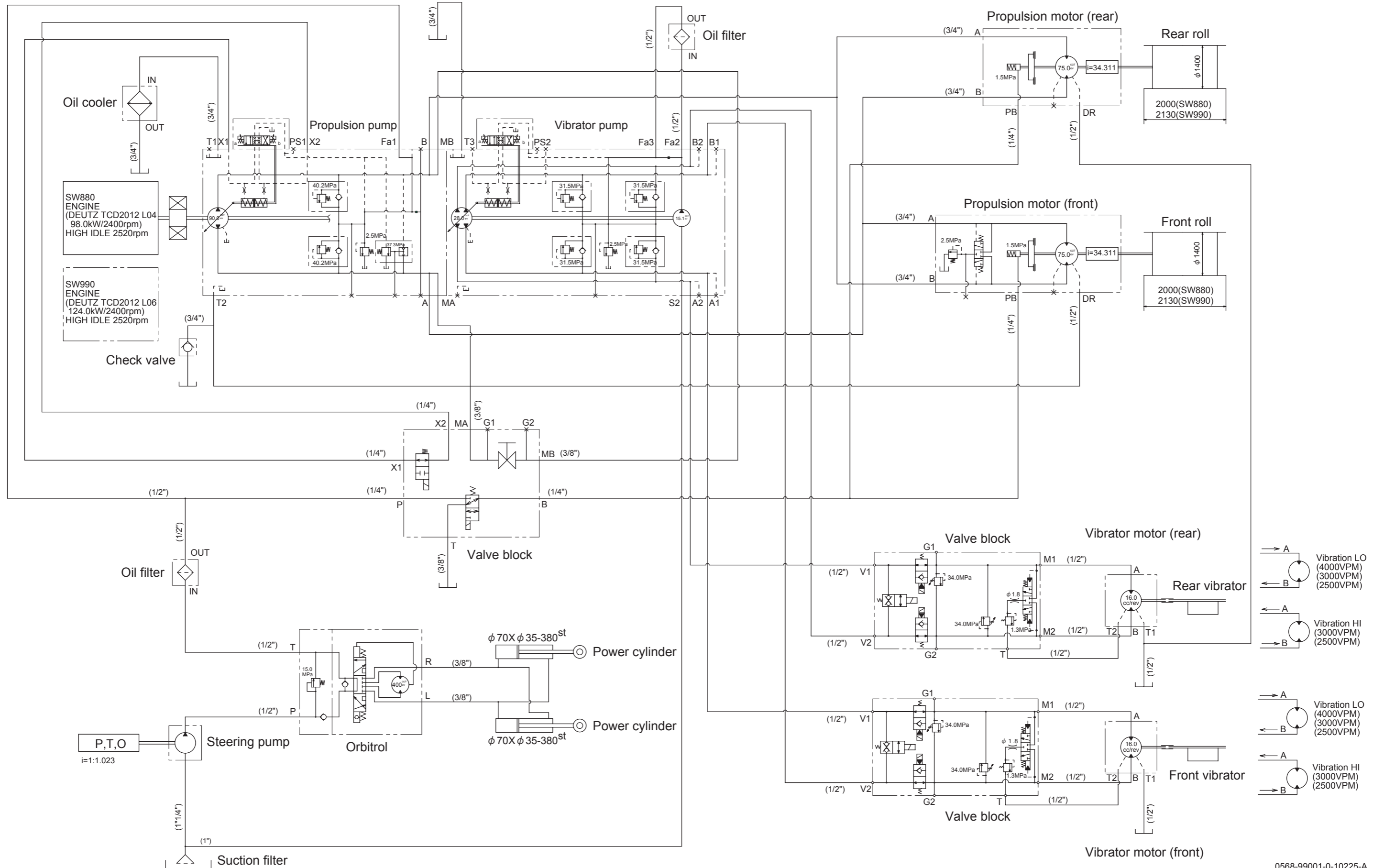

2. PROPULSION HYDRAULIC SYSTEM

2-1. Propulsion Hydraulic Piping (1)

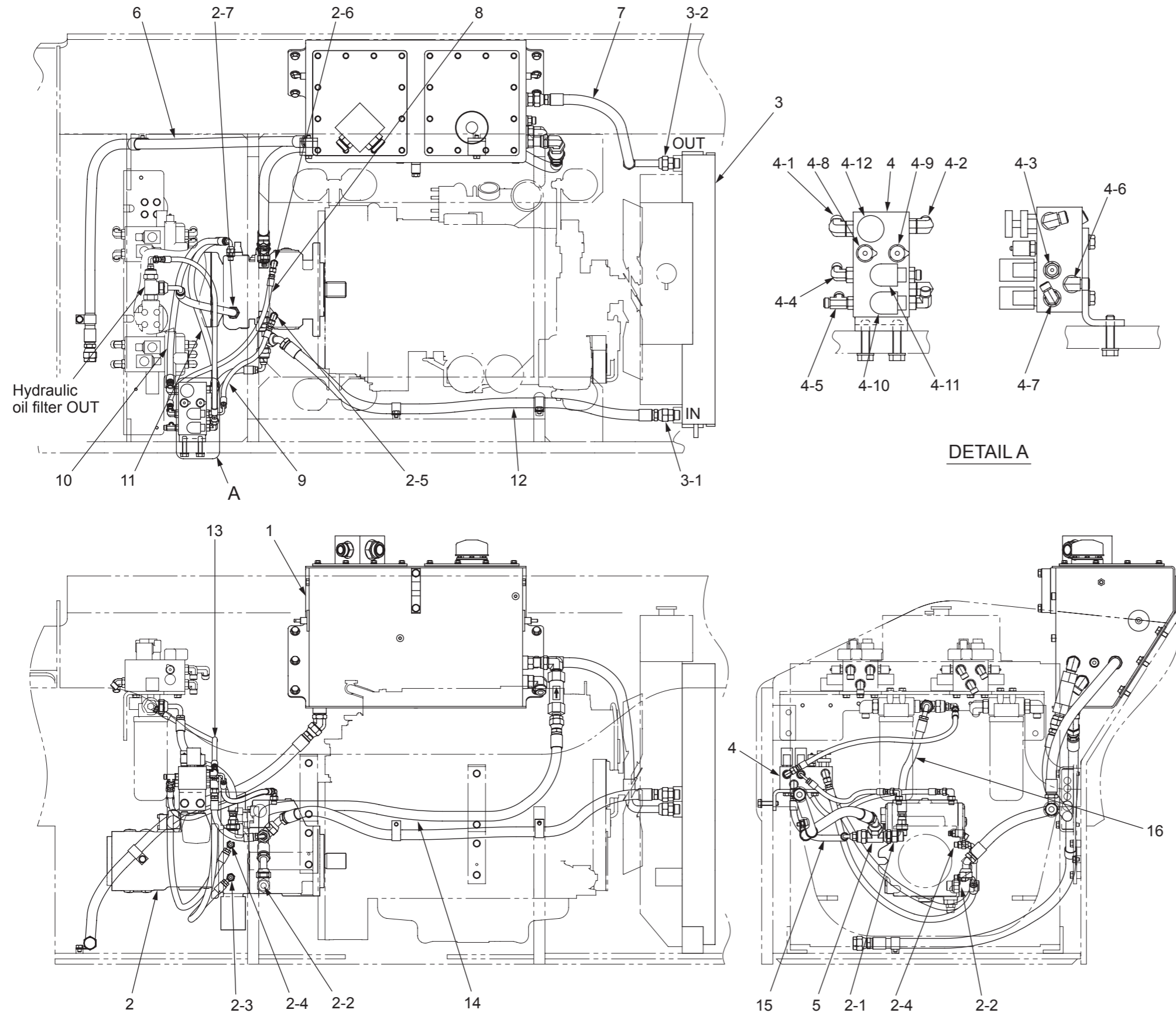

- (1) Hydraulic oil tank
- (2) Propulsion pump
 - (2-1) Drain port (via oil cooler) : 1 1/16-12UN
 - (2-2) Drain port : 1 1/16-12UN
 - (2-3) Bypass valve port (for port A) : 7/16-20UNF
 - (2-4) Bypass valve port (for port B) : 7/16-20UNF
 - (2-5) Neutral solenoid valve port : 9/16-18UNF
 - (2-6) Neutral solenoid valve port : 9/16-18UNF
 - (2-7) Filter port : M22×1.5
- (3) Oil cooler
 - (3-1) IN : 1 1/16-12UNF
 - (3-2) OUT : 1 1/16-12UNF
- (4) Valve block
 - (4-1) Port MA : 9/16-18UNF
 - (4-2) Port MB : 9/16-18UNF
 - (4-3) Port X1 : 9/16-18UNF
 - (4-4) Port X2 : 9/16-18UNF
 - (4-5) Port B1 : 9/16-18UNF
 - (4-6) Port T : 9/16-18UNF
 - (4-7) Port P : 9/16-18UNF
 - (4-8) High-pressure gauge coupling (forward) : 9/16-18UNF
 - (4-9) High-pressure gauge coupling (reverse) : 9/16-18UNF
 - (4-10) Brake solenoid valve : 9/16-18UNF
 - (4-11) Neutral solenoid valve : 9/16-18UNF
 - (4-12) Bypass valve : 9/16-18UNF
- (5) Tee
- (6) Hose : Hydraulic oil tank drain
- (7) Hose : (3-2)→Hydraulic oil tank
- (8) Hose : (2-6)↔(4-4)
- (9) Hose : (2-5)↔(4-3)
- (10) Hose : (2-4)↔(4-1)
- (11) Hose : (2-3)↔(4-2)
- (12) Hose : Tee (2-1→)→(3-1)
- (13) Hose : Hydraulic oil filter→(4-7)
- (14) Hose : (2-2)→Hydraulic oil tank
- (15) Hose : (4-6)→Tee (→3-1)
- (16) Hose : Hydraulic oil filter→(2-7)

• The figures (such as 1-1 and 2-1) show each port and the arrow (↔; →) symbols show the hose connection and the direction of the flow of the oil.

(NOTICE)

• The hose adapter uses an O-ring face seal.

2-2. Propulsion Hydraulic Piping (2)

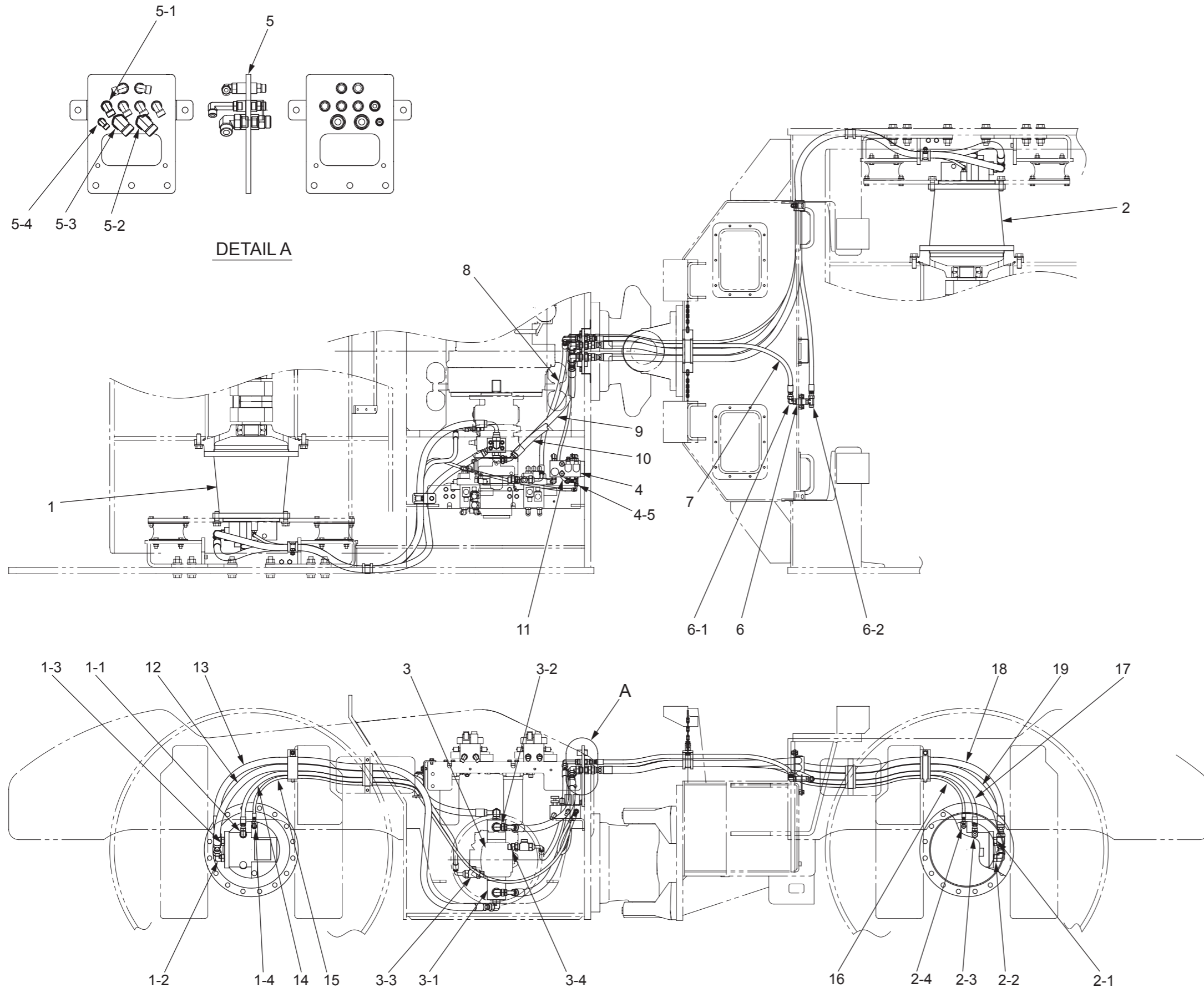

- (1) Propulsion motor (front)
 - (1-1) Drain port : 7/8-14UNF
 - (1-2) Port B (forward) : SAE 1"
 - (1-3) Port A (reverse) : SAE 1"
 - (1-4) Brake port : 9/16-18UNF
- (2) Propulsion motor (rear)
 - (2-1) Port A (reverse) : SAE 1"
 - (2-2) Port B (forward) : SAE 1"
 - (2-3) Drain port : 7/8-14UNF
 - (2-4) Brake port : 9/16-18UNF
- (3) Propulsion pump
 - (3-1) Port A (reverse) : SAE 1"
 - (3-2) Port B (forward) : SAE 1"
 - (3-3) Drain port : 1 1/16-12UNF
 - (3-4) Drain port : 1 1/16-12UNF
- (4) Valve block
 - (4-5) Port B1 : 9/16-18UNF
- (5) Bracket
 - (5-1) Socket : 3/4-16UNF
 - (5-2) Socket : 1 1/16-12UNF
 - (5-3) Socket : 1 1/16-12UNF
 - (5-4) Socket : 7/16-20UNF
- (6) Bracket
 - (6-1) Socket : 3/4-16UNF
 - (6-2) Socket : 3/4-16UNF
- (7) Hose : (6-1)→(5-1)
- (8) Hose : (5-1)→(3-4)
- (9) Hose : (3-1)↔(5-3)
- (10) Hose : (3-2)↔(5-2)
- (11) Hose : (4-5)↔(5-4)
- (12) Hose : (3-2)↔(1-2)
- (13) Hose : (3-1)↔(1-3)
- (14) Hose : (1-1)→(3-3)
- (15) Hose : (4-5)↔(1-4)
- (16) Hose : (5-4)↔(2-4)
- (17) Hose : (2-3)→(6-2)
- (18) Hose : (5-2)↔(2-1)
- (19) Hose : (5-3)↔(2-2)

• The figures (such as 1-1 and 2-1) show each port and the arrow (↔; →) symbols show the hose connection and the direction of the flow of the oil.

(NOTICE)

• The hose adapter uses an O-ring face seal.

2-3. Hydraulic Component Specifications

2-3-1. Hydraulic pump assembly (propulsion + vibrator)

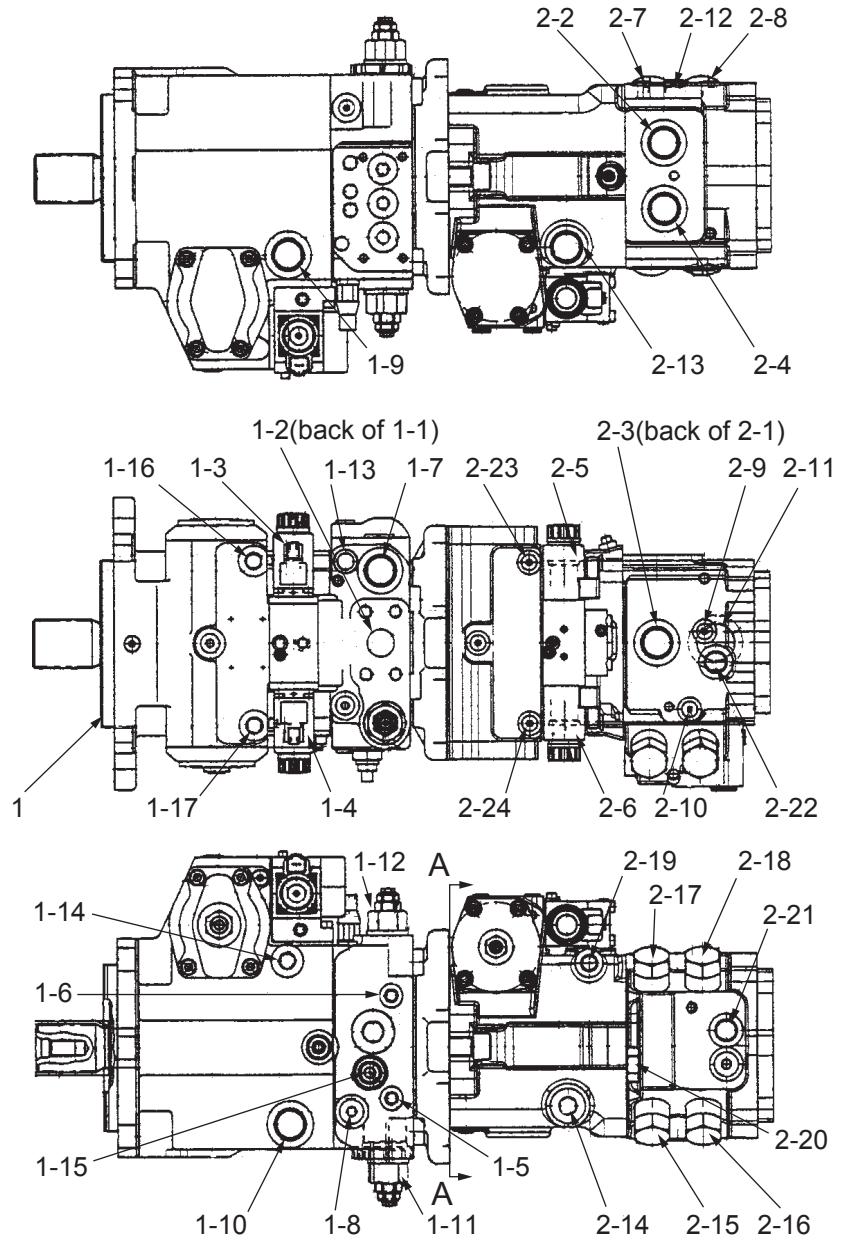

SECTION A-A 2-12 2-7,2-8

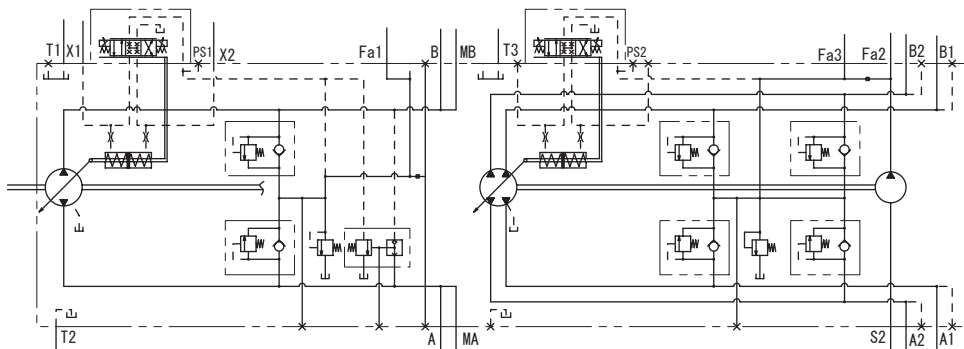

Pump circuit diagram

- (1) Propulsion pump Model : AA4VG90EP1/32
- (1-1) Port A (reverse) : SAE 1"
 - (1-2) Port B (forward) : SAE 1"
 - (1-3) Solenoid valve a (reverse)
 - (1-4) Solenoid valve b (forward)
 - (1-5) High-pressure gauge port (for port A) : 7/16-20UNF
 - (1-6) High-pressure gauge port (for port B) : 7/16-20UNF
 - (1-7) Charge supply port : 1 1/16-12UN
 - (1-8) Charge pressure gauge port : 3/4-16UNF
 - (1-9) Drain port : 1 1/16-12UN
 - (1-10) Drain port : 1 1/16-12UN
 - (1-11) High-pressure relief valve (for port A)
 - (1-12) High-pressure relief valve (for port B)
 - (1-13) Pressure override valve
 - (1-14) Control pressure port : 9/16-18UNF
 - (1-15) Charge relief valve
 - (1-16) Servo pressure gauge port : 9/16-18UNF
 - (1-17) Servo pressure gauge port : 9/16-18UNF

Specifications

- Displacement : 90 cm³/rev (5.49 cu.in./rev)
- Relief valve pressure setting : 40.2 MPa (5,829 psi)
- Pressure override pressure setting : 37.3 MPa (5,409 psi)
- Charge relief pressure setting : 2.5 MPa (363 psi) (at 2,600 min⁻¹)

- (2) Vibrator pump Model: A30VG028EP3/10-S
- (2-1) Port A1 (front low amplitude) : 1 1/16-12UN
 - (2-2) Port A2 (rear low amplitude) : 1 1/16-12UN
 - (2-3) Port B1 (front high amplitude) : 1 1/16-12UN
 - (2-4) Port B2 (rear high amplitude) : 1 1/16-12UN
 - (2-5) Solenoid valve a (high amplitude)
 - (2-6) Solenoid valve b (low amplitude)
 - (2-7) High-pressure gauge port (for port A1) : 7/16-20UNF
 - (2-8) High-pressure gauge port (for port A2) : 7/16-20UNF
 - (2-9) High-pressure gauge port (for port B1) : 7/16-20UNF
 - (2-10) High-pressure gauge port (for port B2) : 7/16-20UNF
 - (2-11) Charge pump suction port : 1 5/16-12UN
 - (2-12) Charge pressure gauge port : 3/4-16UNF
 - (2-13) Drain port : 1 1/16-12UN
 - (2-14) Drain port : 1 1/16-12UN
 - (2-15) High-pressure relief valve (for port A1)
 - (2-16) High-pressure relief valve (for port A2)
 - (2-17) High-pressure relief valve (for port B1)
 - (2-18) High-pressure relief valve (for port B2)
 - (2-19) Charge pressure gauge port : 9/16-18UNF
 - (2-20) Charge relief valve
 - (2-21) Filter port (to filter) : 3/4-16UNF
 - (2-22) Filter port (from filter) : 3/4-16UNF
 - (2-23) Servo pressure gauge port : 7/16-20UNF
 - (2-24) Servo pressure gauge port : 7/16-20UNF

Specifications

- Displacement : 56 cm³/rev (3.42 cu.in./rev)
- Relief valve pressure setting : 31.5 MPa (4,568 psi)
- Charge relief pressure setting : 2.5 MPa (363 psi) (at 2,600 min⁻¹)

Charge pump (for vibration)

- Displacement : 15.1 cm³/rev (2,190 cu.in./rev)

- Propulsion and vibrator pump assembly weight : 120 kg (265 lbs.)

2-3-2. Internal structure of hydraulic pump (propulsion pump)

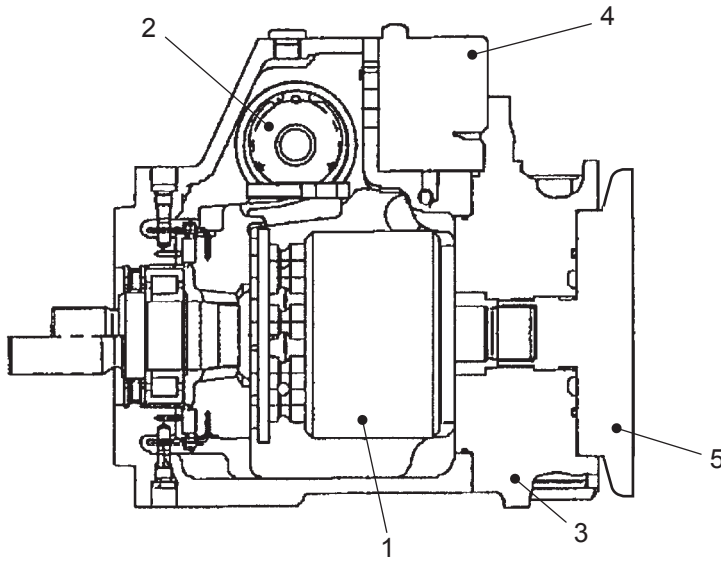

SW880-04015

- (1) Rotary group
- (2) Control, hydraulic
- (3) Port plate with valves
- (4) Control module
- (5) Pump support plate

(1) Rotary group

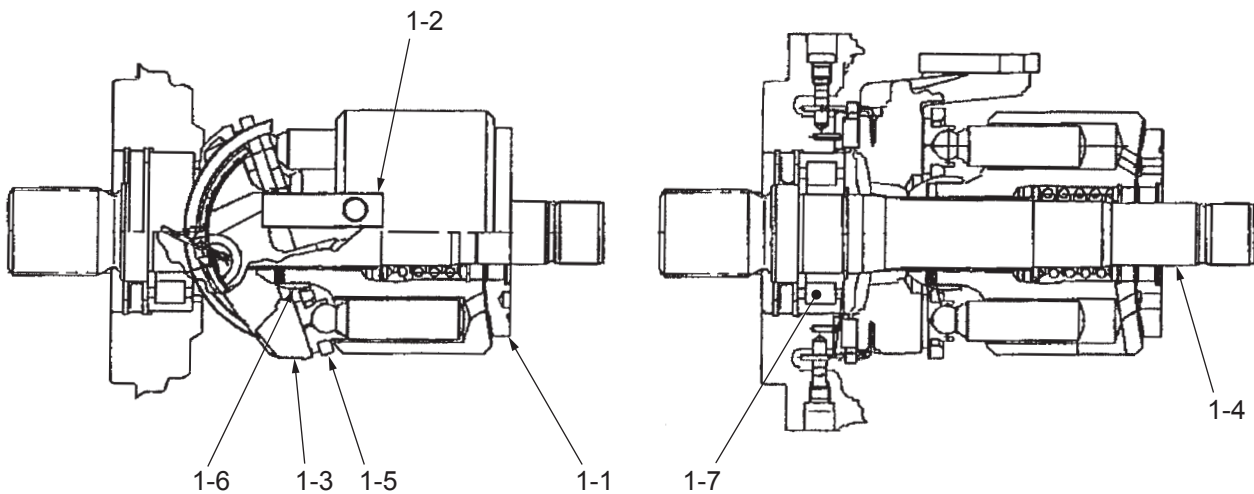

SW880-04016

- (1-1) Cylinder assembly with control plate
- (1-2) Piston-slipper pad
- (1-3) Cradle
- (1-4) Drive shaft
- (1-5) Retaining plate
- (1-6) Retaining ball
- (1-7) Plain roller bearing

(2) Control, hydraulic

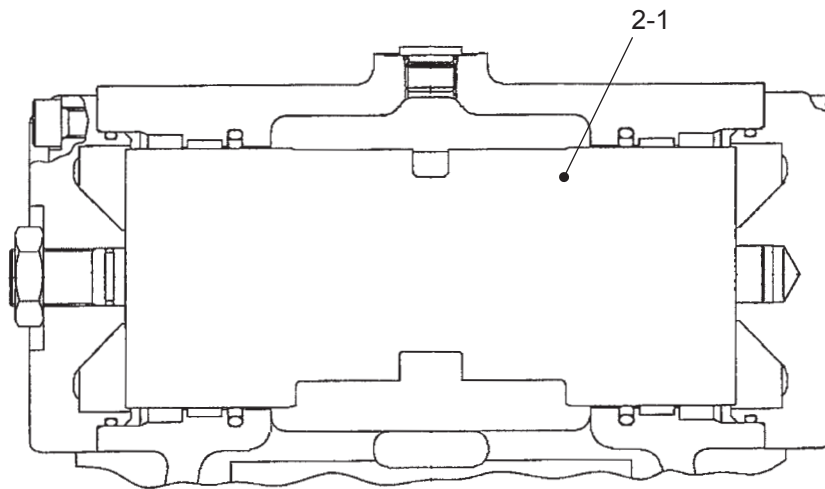

SW880-04017

(2-1) Positioning piston complete

(2-1) Positioning piston complete

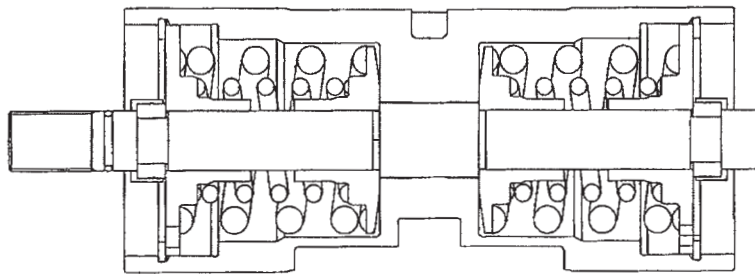

SW880-04018

(3) Port plate with valves

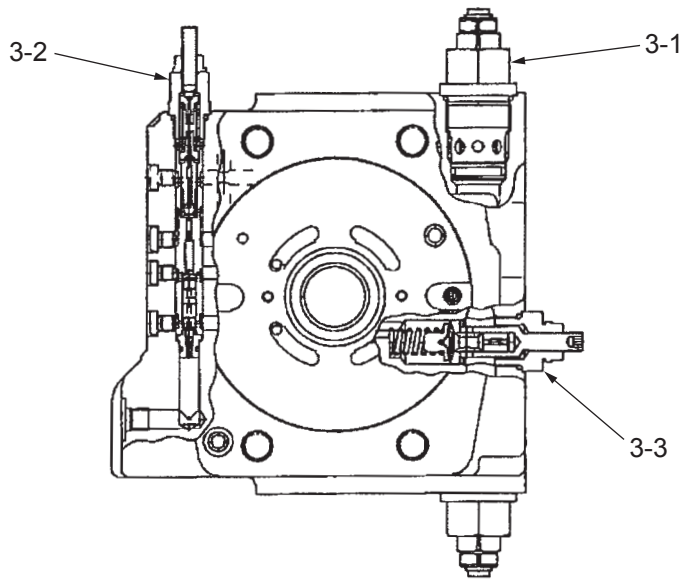

SW880-04019

- (3-1) Pressure relief valve
- (3-2) Pressure override valve
- (3-3) Pressure relief valve

(3-1) Pressure relief valve

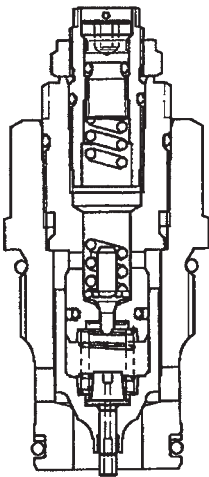

SW880-04020

(3-2) Pressure override valve

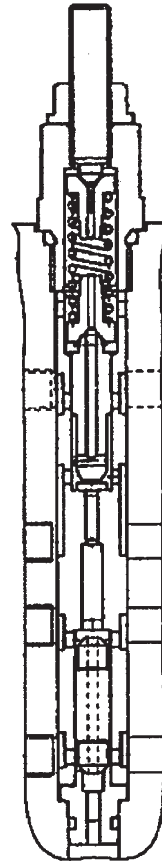

(3-3) Pressure relief valve

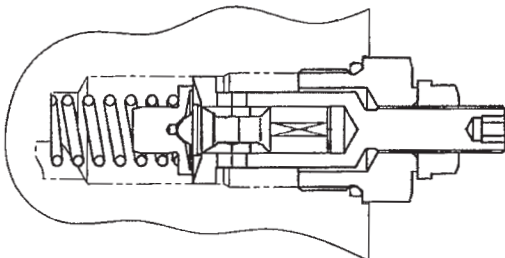

SW880-04021

SW880-04022

(4) Control module

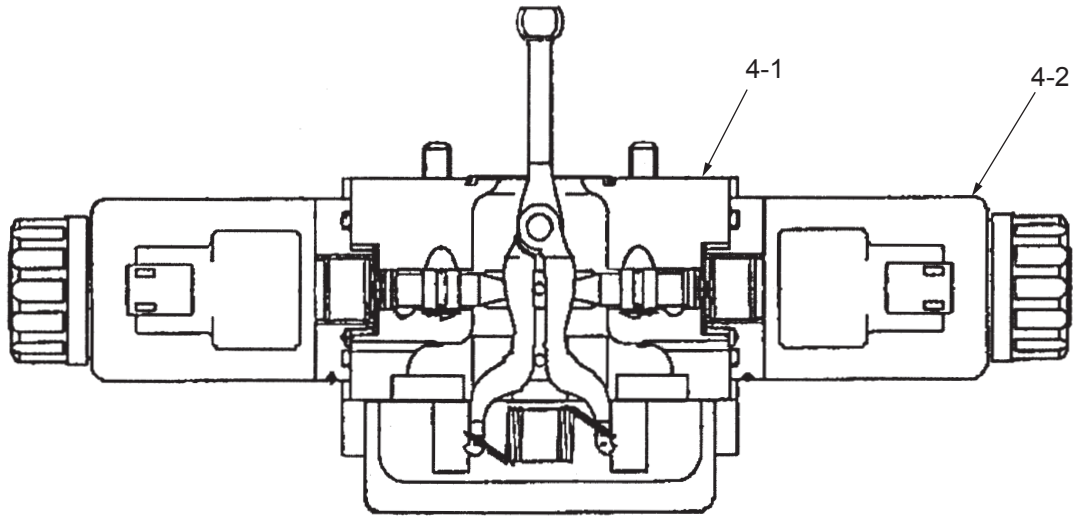

SW880-04023

- (4-1) Control module
- (4-2) Proportional solenoid

(5) Pump support plate

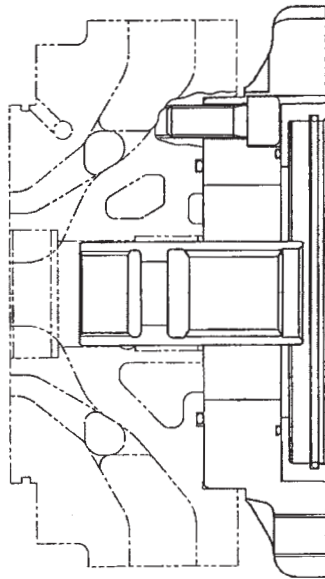

SW880-04024

2-3-3. Internal structure of hydraulic pump (vibrator pump)

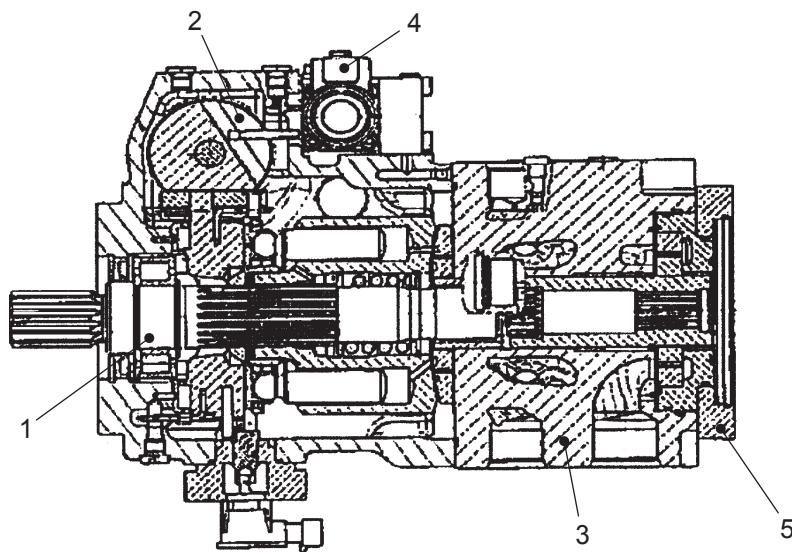

SW880-04025

- (1) Rotary group
- (2) Control, hydraulic
- (3) Port plate with valves
- (4) Control module
- (5) Internal gear pump

(1) Rotary group

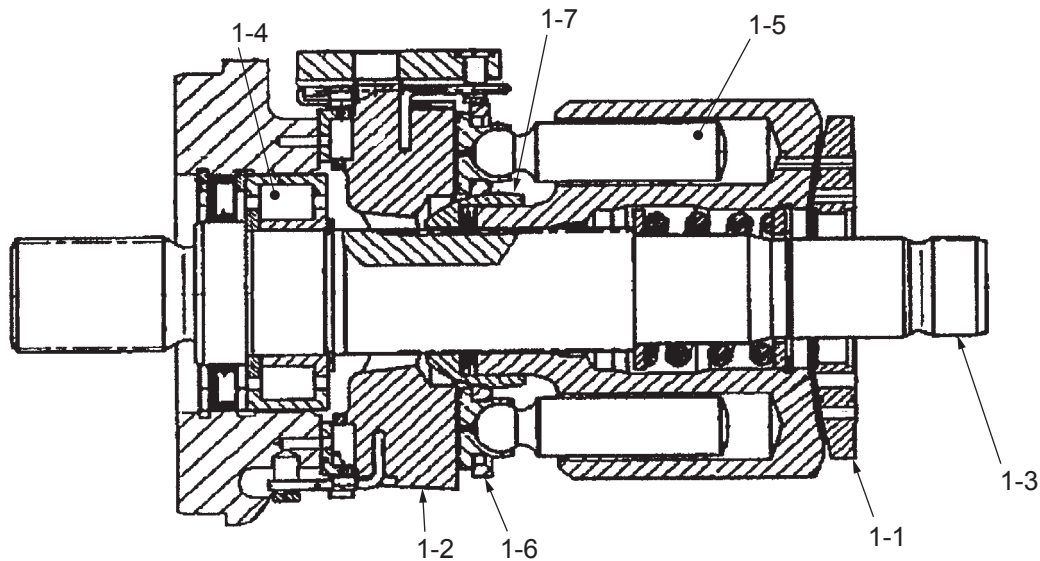

SW880-04026

- (1-1) Control plate, right-handrot
- (1-2) Cradle
- (1-3) Drive shaft
- (1-4) Plain roller bearing
- (1-5) Piston-slipper pad
- (1-6) Retaining plate
- (1-7) Retaining ball

(2) Control, hydraulic

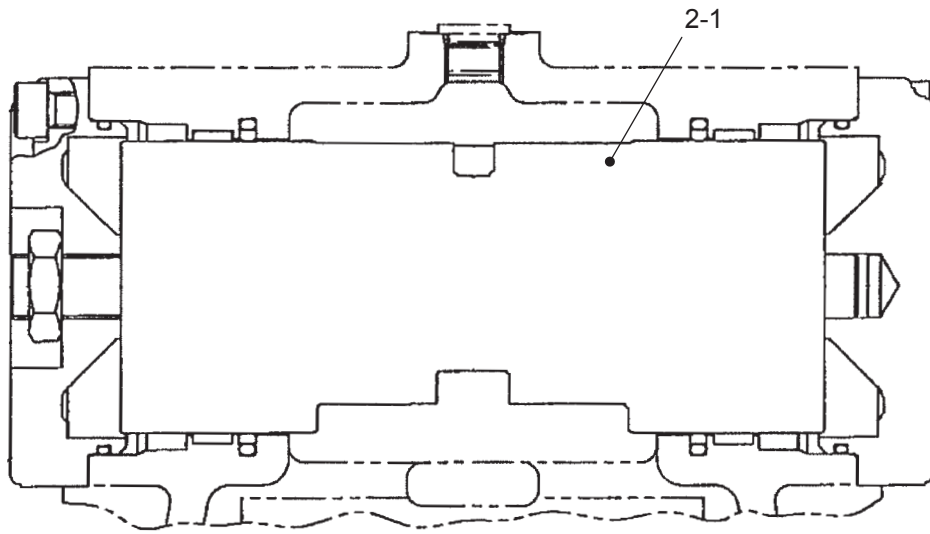

SW880-04027

(2-1) Positioning piston complete

(2-1) Positioning piston complete

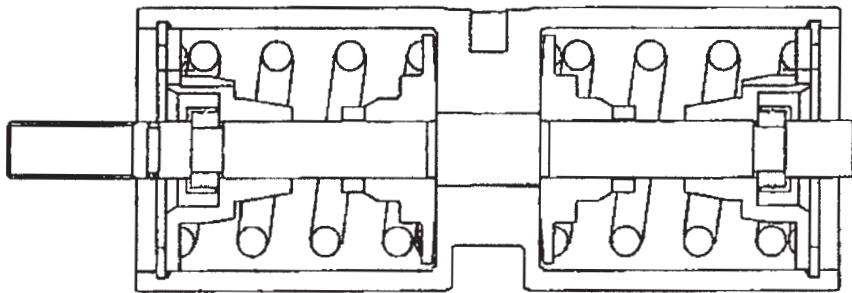

SW880-04028

(3) Port plate with valves

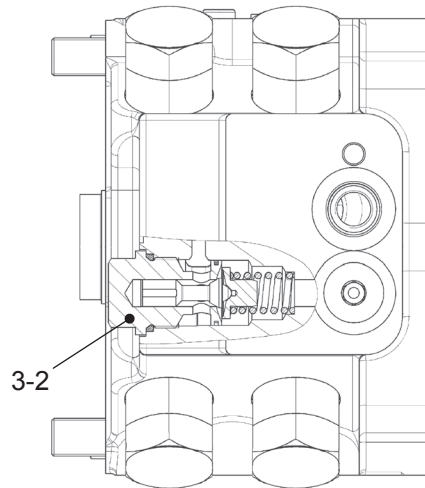
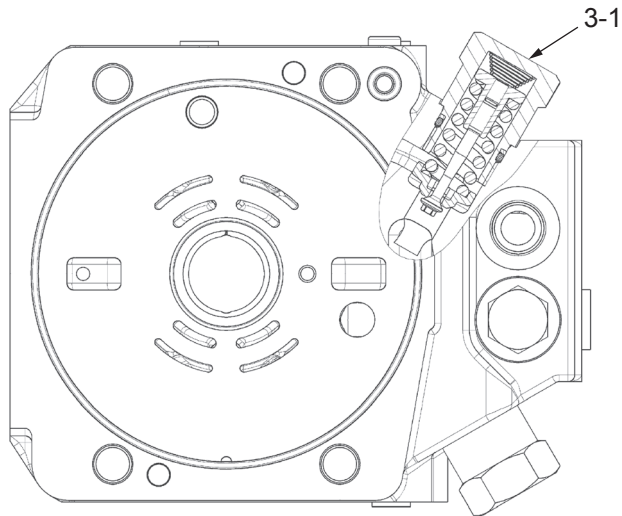

SW880-04029

- (3-1) Pressure relief valve
- (3-2) Pressure relief valve

(3-1) Pressure relief valve

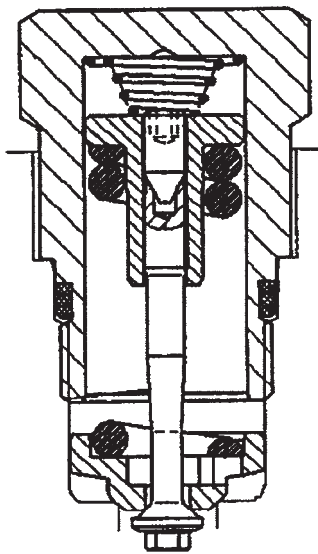

SW880-04030

(3-2) Pressure relief valve

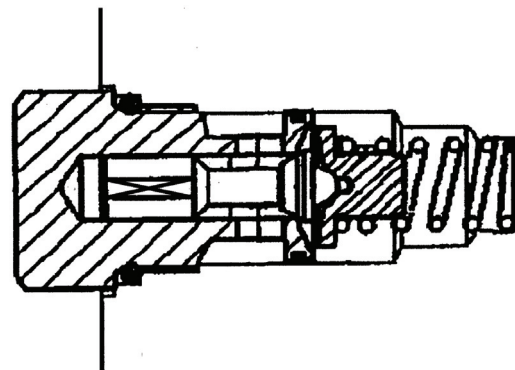

SW330-04031

(4) Control module

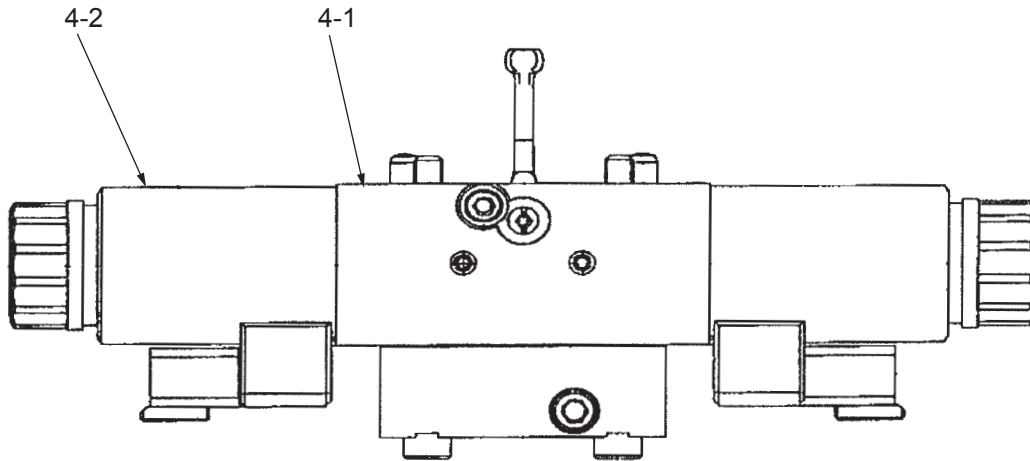

SW330-04032

- (4-1) Control module
- (4-2) Proportional solenoid

(5) Internal gear pump

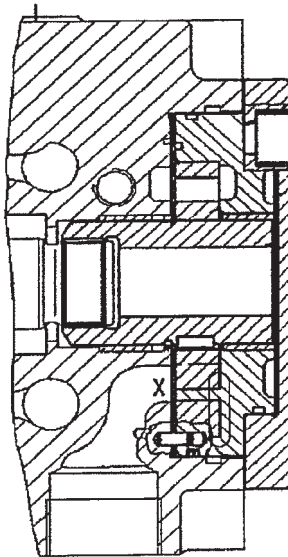

SW880-04033

2-3-4. Propulsion hydraulic motor (front)

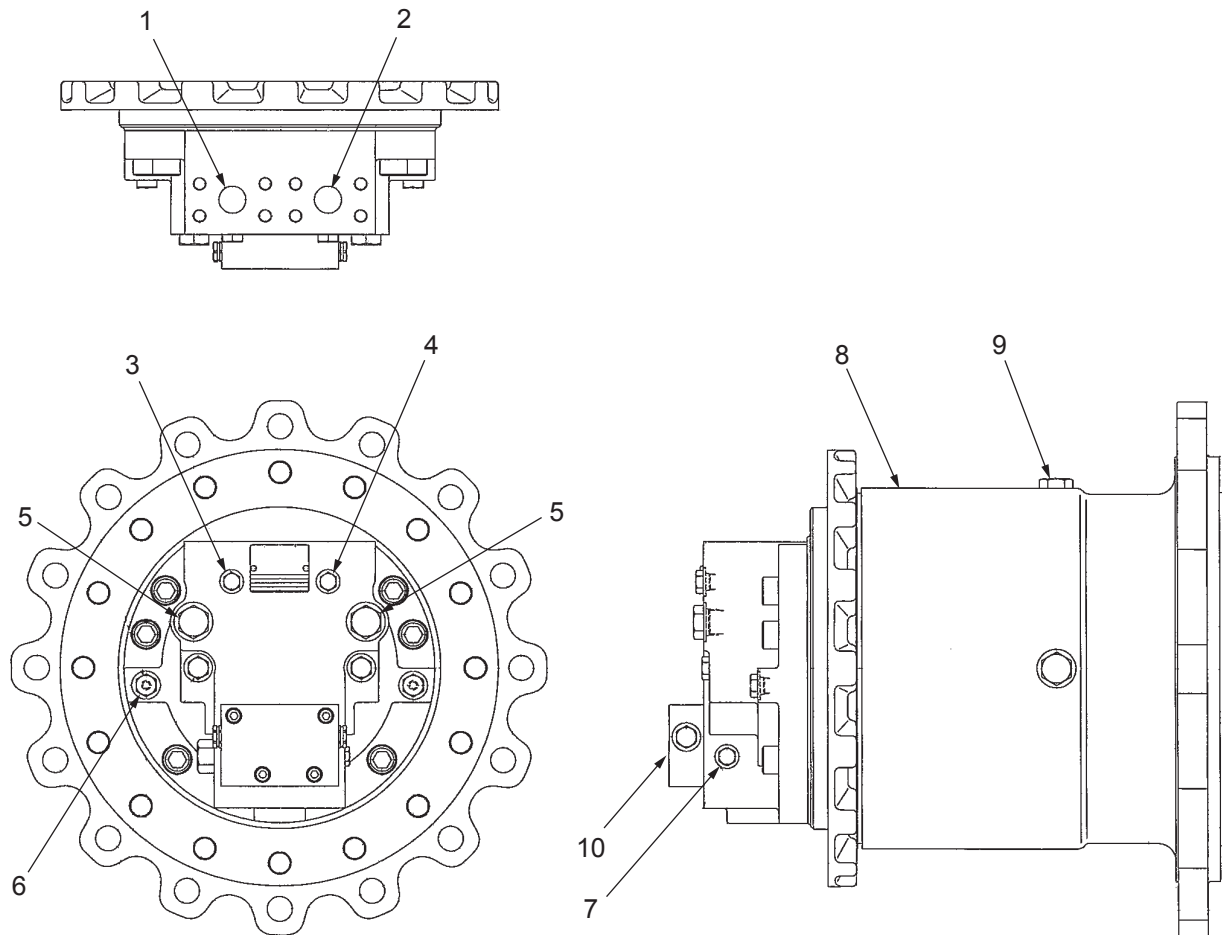

SW880-04002

(1) Port B (forward)	: SAE 1"	(6) Brake port	: 9/16-18UNF
(2) Port A (reverse)	: SAE 1"	(7) Charge pressure gauge port	: 7/16-20UNF
(3) High-pressure gauge port (for port B)	: 9/16-18UNF	(8) Reduction gear	
(4) High-pressure gauge port (for port A)	: 9/16-18UNF	(9) Filler cap	: 7/8-14UNF
(5) Drain port	: 7/8-14UNF	(10) Shuttle valve	

Motor specifications

- Model : BM75BN-40E-HBF
- Displacement: : 65.7 cm³/rev (4.0 cu.in./rev)
- Maximum working pressure : 41.8 MPa (6,061 psi)
- Charge pressure setting pressure (at 15 L/min) : 2.27 – 2.54 MPa (329 – 368 psi)

Reduction gear specifications

- Reduction ratio : 1/39.000

- Propulsion hydraulic motor weight : 191 kg (421 lbs.)

2-3-5. Internal structure of propulsion hydraulic motor (front)

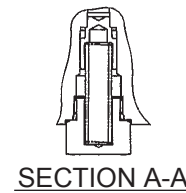
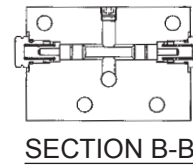
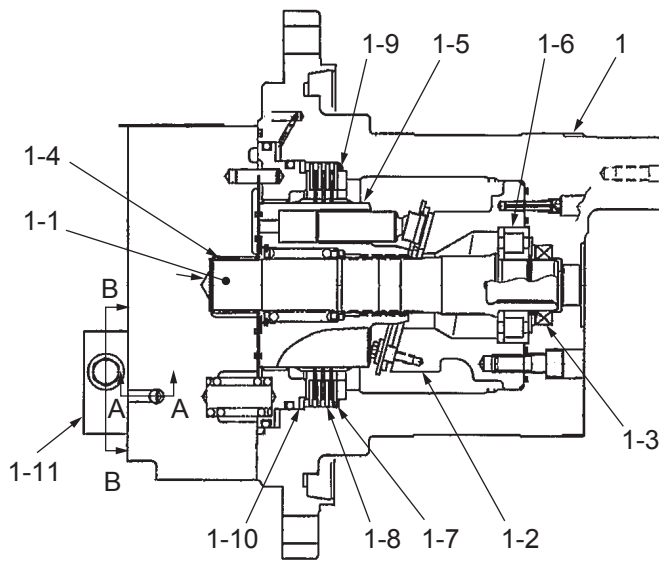

SW880-04003

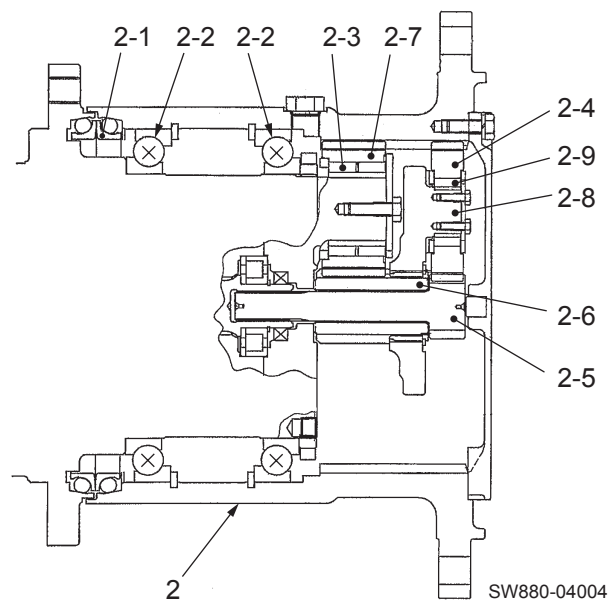

SW880-04004

- (1) Motor
 - (1-1) Shaft
 - (1-2) Swashplate assembly
 - (1-3) Oil seal
 - (1-4) Journal bearing
 - (1-5) Cylinder block kit
 - (1-6) Roller bearing
 - (1-7) Friction plate
 - (1-8) Separate plate
 - (1-9) Break stopper
 - (1-10) Piston break
 - (1-11) Shuttle valve

- (2) Reduction gear
 - (2-1) Floating seal kit
 - (2-2) Angular bearing
 - (2-3) Needle roller
 - (2-4) Primary planetary gear
 - (2-5) Primary sun gear
 - (2-6) Secondary sun gear
 - (2-7) Secondary planetary gear
 - (2-8) Carrier
 - (2-9) Needle roller

2-3-6. Propulsion hydraulic motor (rear)

Speed sensor specifications

• Supply power voltage	5V ±0.25V
• Maximum required current	25 mA
• Output signal	21 pulses/rev.
• Connector	DEUTSCH DTM-Series 6-Pin
	DTM 04-6P

Sensor pin I/O	
1	Output signal 2
2	Revolving direction output
3	Output signal 1
4	Supply power voltage
5	0 V (GND)
6	-

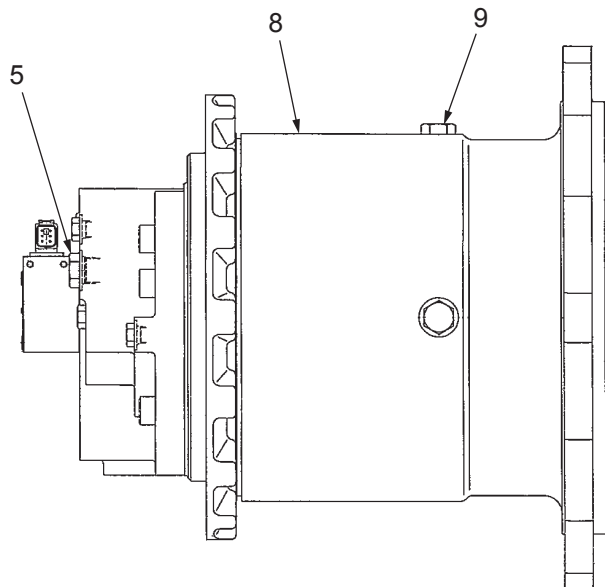
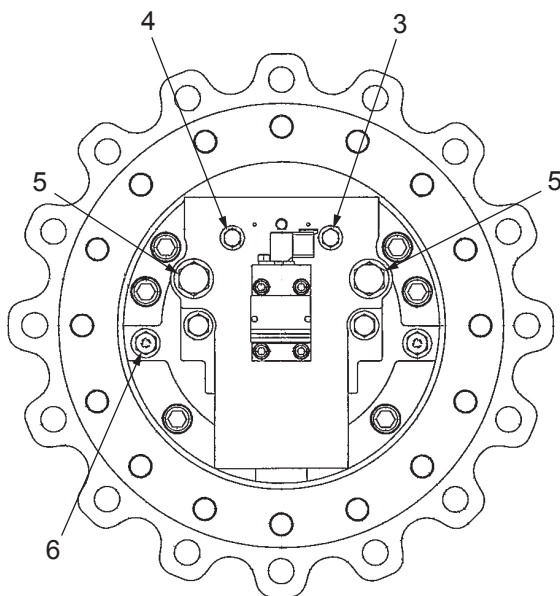
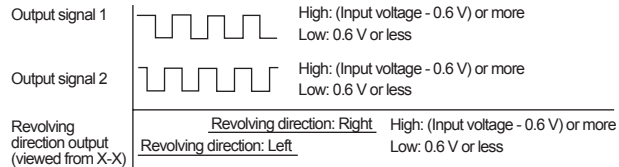
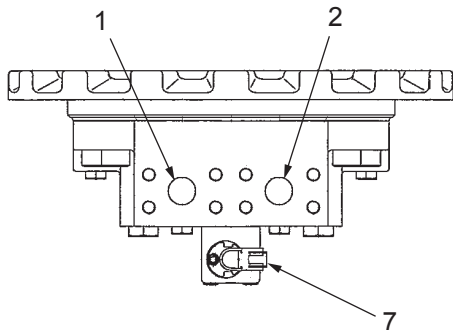

SW880-04005

- | | | | |
|---|--------------|------------------------------|--------------|
| (1) Port B (forward) | : SAE 1" | (6) Parking brake pilot port | : 9/16-18UNF |
| (2) Port A (reverse) | : SAE 1" | (7) Speed sensor | |
| (3) High-pressure gauge port (for port B) | : 9/16-18UNF | (8) Reduction gear | |
| (4) High-pressure gauge port (for port A) | : 9/16-18UNF | (9) Filler cap | : 7/8-14UNF |
| (5) Drain port | : 7/8-14UNF | | |

Motor specifications

- Model : BM75BR-40EHB
- Displacement : 65.7 cm³/rev (4.0 cu.in./rev)
- Maximum working pressure : 41.8 MPa (6,061 psi)

Reduction gear specifications

- Reduction ratio : 1/39.000

- Propulsion hydraulic motor weight : 192 kg (423 lbs.)

2-3-7. Internal structure of propulsion hydraulic motor (rear)

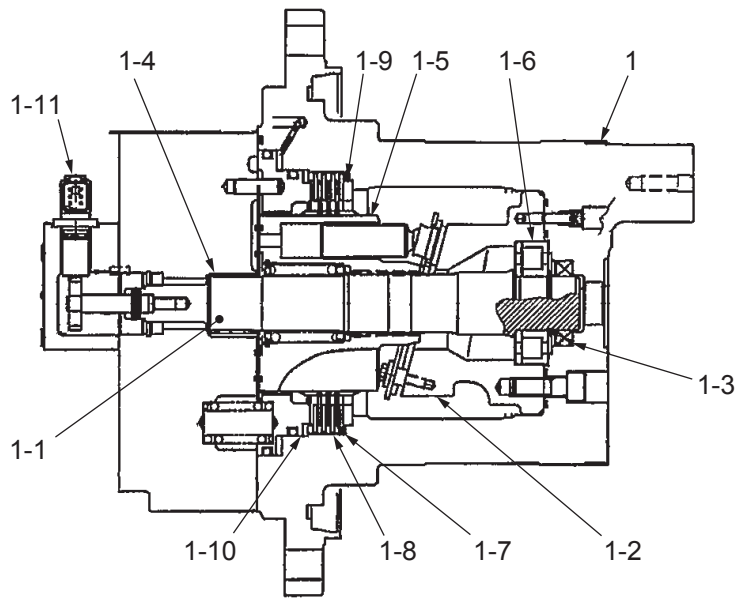

SW880-04006

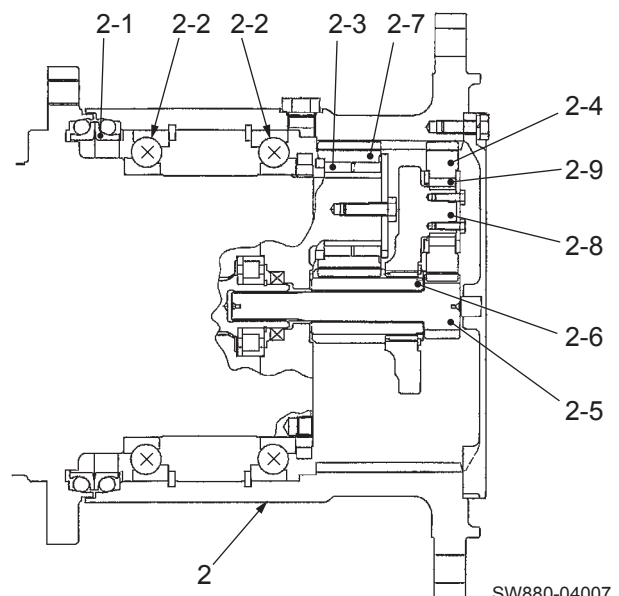

SW880-04007

(1) Motor

- (1-1) Shaft
- (1-2) Swashplate assembly
- (1-3) Oil seal
- (1-4) Journal bearing
- (1-5) Cylinder block kit
- (1-6) Roller bearing
- (1-7) Friction plate
- (1-8) Separate plate
- (1-9) Break stopper
- (1-10) Piston break
- (1-11) Speed sensor

(2) Reduction gear

- (2-1) Floating seal kit
- (2-2) Angular bearing
- (2-3) Needle roller
- (2-4) Primary planetary gear
- (2-5) Primary sun gear
- (2-6) Secondary planetary gear
- (2-7) Secondary sun gear
- (2-8) Carrier
- (2-9) Needle roller

2-3-8. Valve block

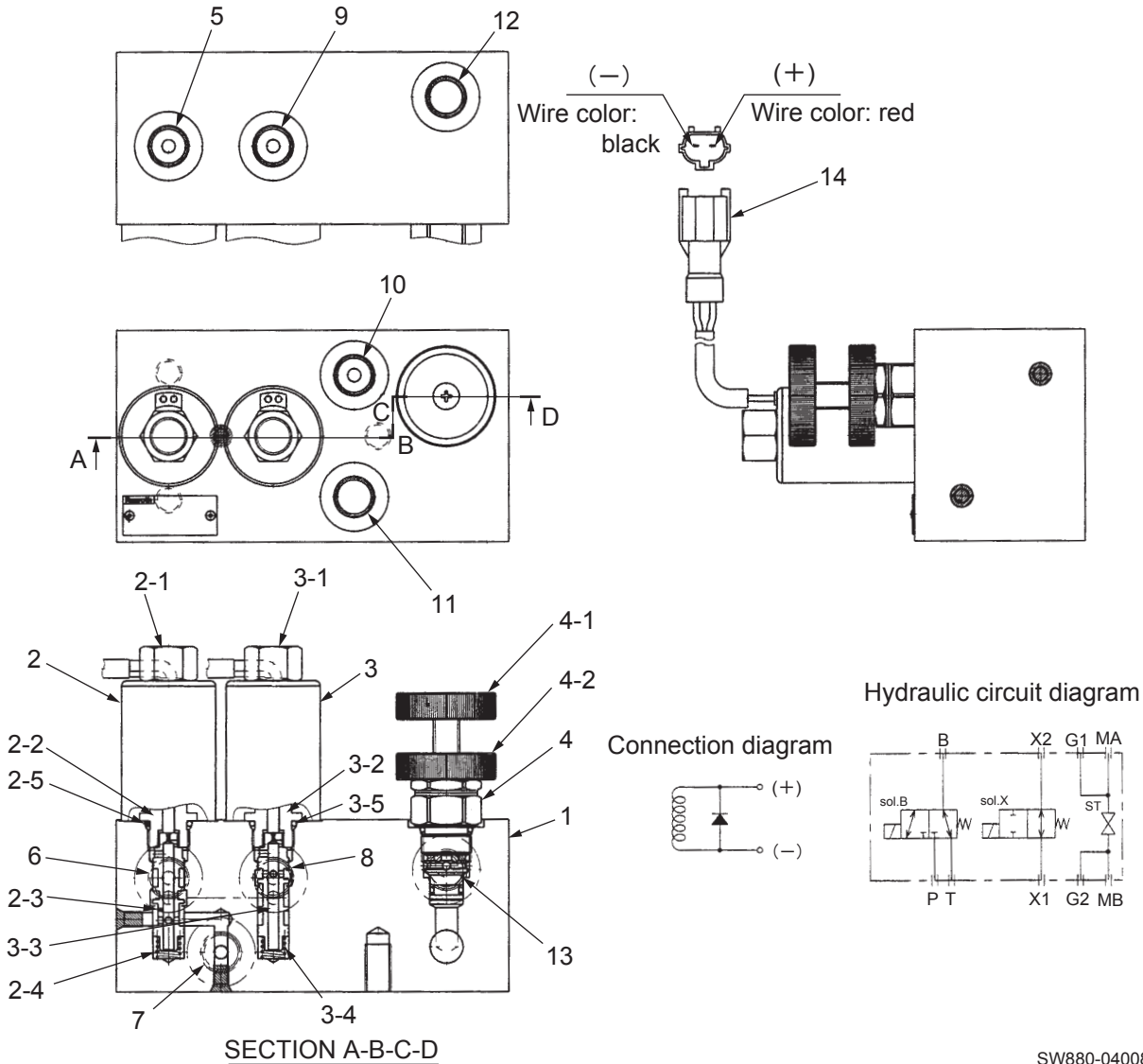

SW880-04008

- | | | |
|-------------------------------|--|--------------|
| (1) Valve block body | (5) Port B | : 9/16-18UNF |
| (2) Brake solenoid valve | (6) Port P | : 9/16-18UNF |
| (2-3) Spool | (7) Port T | : 9/16-18UNF |
| (2-4) Spring | (8) Port X1 | : 9/16-18UNF |
| (2-5) O-ring (1B P14) | (9) Port X2 | : 9/16-18UNF |
| (3) Neutral solenoid valve | (10) High-pressure gauge port
(propulsion circuit forward side) | : 9/16-18UNF |
| (3-3) Spool | (11) High-pressure gauge port
(propulsion circuit reverse side) | : 9/16-18UNF |
| (3-4) Spring | (12) Port MA | : 9/16-18UNF |
| (3-5) O-ring (1B P14) | (13) Port MB | : 9/16-18UNF |
| (4) Bypass valve | (14) Connector | |
| (4-1) Open/close valve handle | | |
| (4-2) Locking handle | | |



- | | |
|------------------|-------------------------------------|
| (2-1) Nut | : 4.9 N·m (3.6 lbf-ft) |
| (2-2) Tube | : 34 ± 3 N·m (25.1 ± 2.2 lbf-ft) |
| (3-1) Nut | : 4.9 N·m (3.6 lbf-ft) |
| (3-2) Tube | : 34 ± 3 N·m (25.1 ± 2.2 lbf-ft) |
| (4) Bypass valve | : 45 ± 6 N·m
(33.2 ± 4.4 lbf-ft) |

Specifications

- Model : VU-615/0-2EF
- Rated pressure : 3.0 MPa (ports B, P, T, X1 and X2) (435 psi)
: 35 MPa (ports MA, MB, G1 and G2) (5075 psi)
- Rated flow : 10 L/min (2.6 gal./min)
- Weight : 6.4 kg (14.1 lb.)

3. VIBRATOR HYDRAULIC SYSTEM

3-1. Vibrator Hydraulic Piping (1)

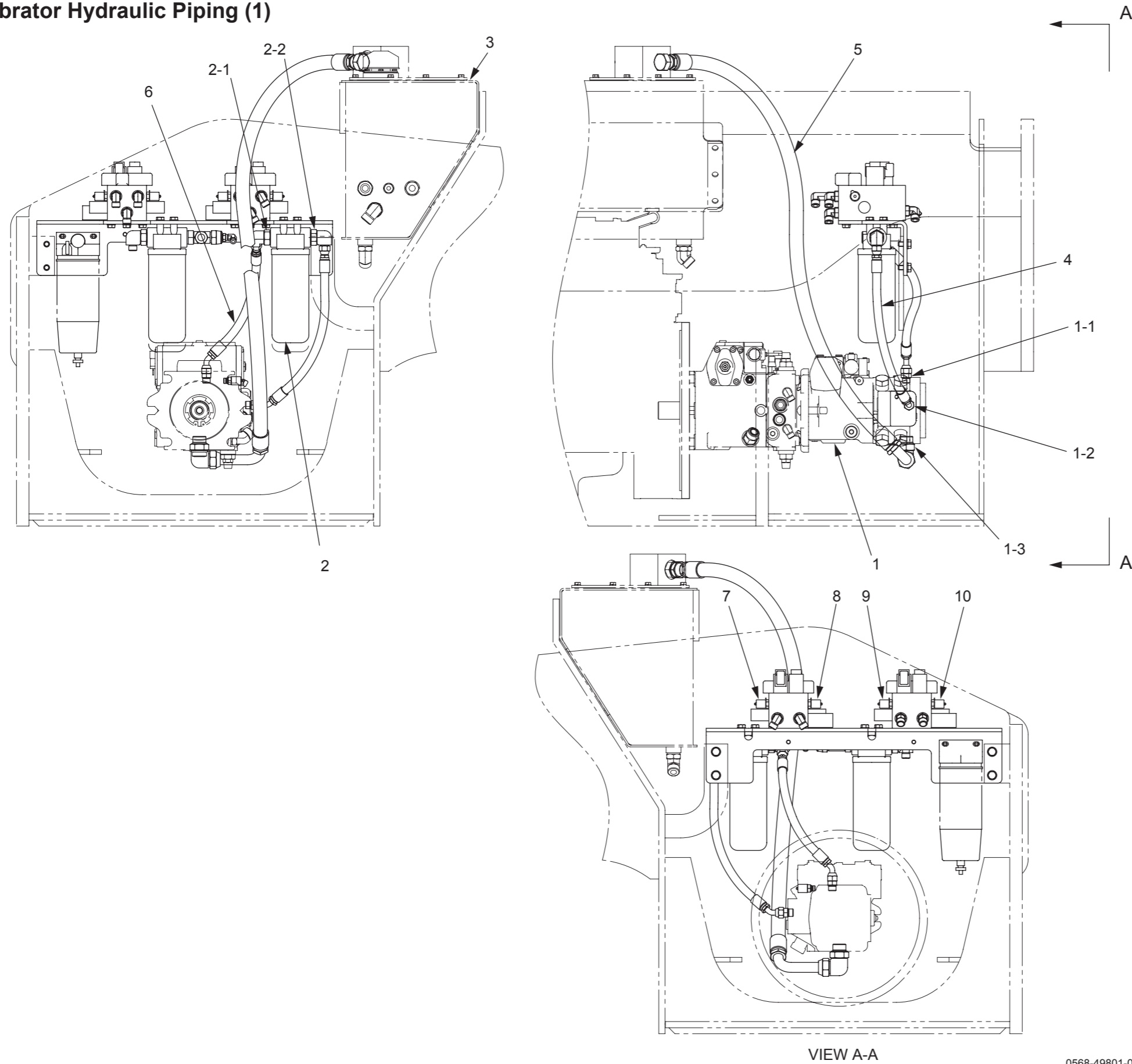

- (1) Vibrator pump
 - (1-1) Filter port (to filter) : 3/4-16UNF
 - (1-2) Filter port (from filter) : 3/4-16UNF
 - (1-3) Charge pump suction port : 1 5/16-12UN
- (2) Hydraulic oil filter
 - (2-1) Filter inlet port : 1 1/16-12UN
 - (2-2) Filter outlet port : 1 1/16-12UN
- (3) Hydraulic oil tank
- (4) Hose : (2-2)→(1-2)
- (5) Hose : Hydraulic oil tank→(1-3)
- (6) Hose : (1-1)→(2-1)
- (7) Coupling (front drum low amplitude side gauge port) : 9/16-18UNF×M6
- (8) Coupling (front drum high amplitude side gauge port) : 9/16-18UNF×M6
- (9) Coupling (rear drum low amplitude side gauge port) : 9/16-18UNF×M6
- (10) Coupling (rear drum high amplitude side gauge port) : 9/16-18UNF×M6

• The figures (such as 1-1 and 2-1) show each port and the arrow (←→; →) symbols show the hose connection and the direction of the flow of the oil.

(NOTICE)

• The hose adapter uses an O-ring face seal.

3-2. Vibrator Hydraulic Piping (2)

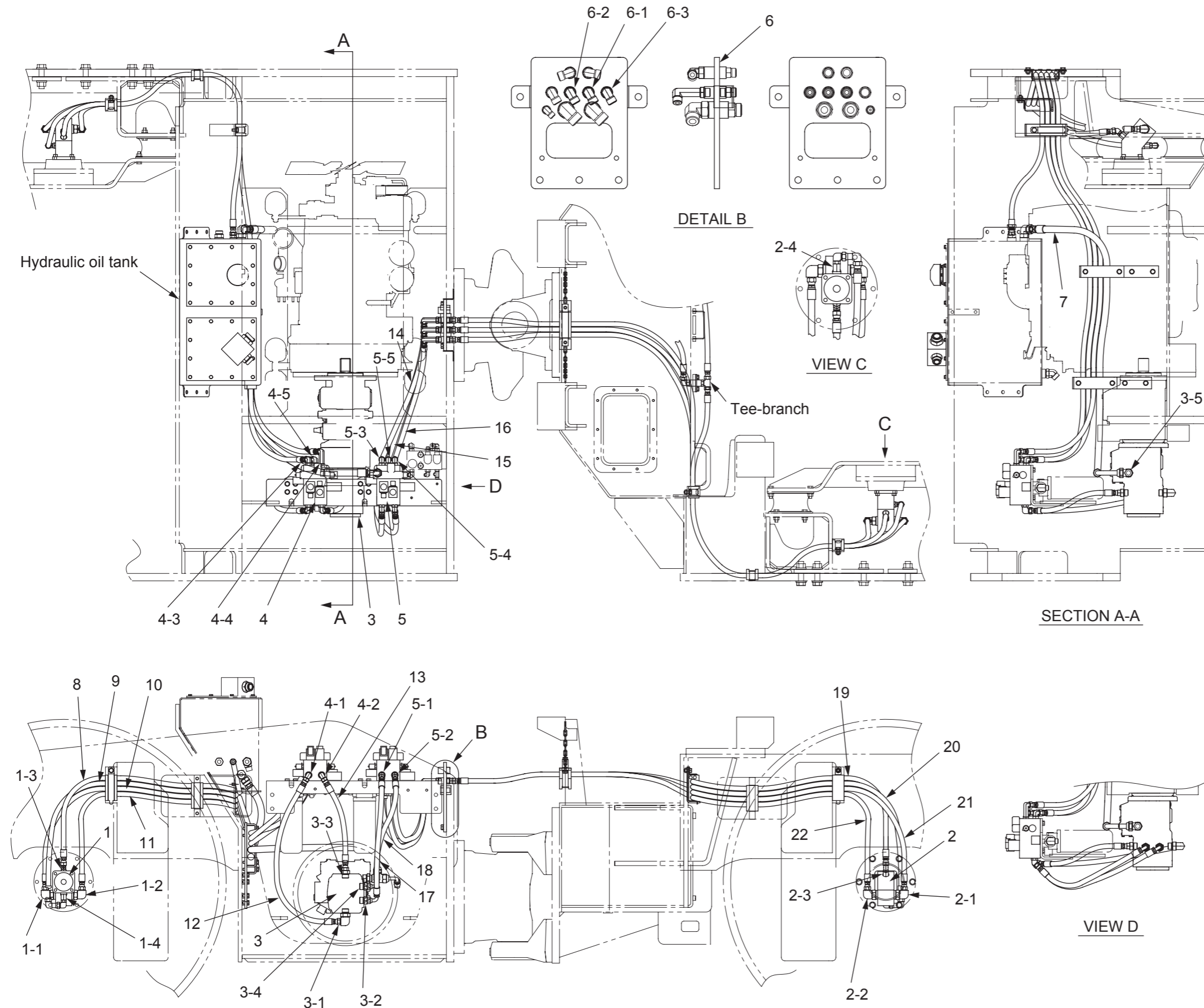

- (1) Vibrator motor (front)
 - (1-1) Port A (low amplitude) : 1 1/16-12UNF
 - (1-2) Port B (high amplitude) : 1 1/16-12UNF
 - (1-3) Port T1 (draining) : 9/16-18UNF
 - (1-4) Port T2 (return from flushing) : 9/16-18UNF
- (2) Vibrator motor (rear)
 - (2-1) Port A (low amplitude) : 1 1/16-12UNF
 - (2-2) Port B (high amplitude) : 1 1/16-12UNF
 - (2-3) Port T1 (draining) : 9/16-18UNF
 - (2-4) Port T2 (return from flushing) : 9/16-18UNF
- (3) Vibrator pump
 - (3-1) Port A1 (front low amplitude) : 1 1/16-12UNF
 - (3-2) Port A2 (rear low amplitude) : 1 1/16-12UNF
 - (3-3) Port B1 (front high amplitude) : 1 1/16-12UNF
 - (3-4) Port B2 (rear high amplitude) : 1 1/16-12UNF
 - (3-5) Drain port : 1 1/16-12UNF
- (4) Valve block (front)
 - (4-1) Port V1 (low amplitude) : 3/4-16UNF
 - (4-2) Port V2 (high amplitude) : 3/4-16UNF
 - (4-3) Port M1 : 3/4-16UNF
 - (4-4) Port M2 : 3/4-16UNF
 - (4-5) Port T (return from flushing) : 3/4-16UNF
- (5) Valve block (rear)
 - (5-1) Port V1 (low amplitude) : 3/4-16UNF
 - (5-2) Port V2 (high amplitude) : 3/4-16UNF
 - (5-3) Port M1 : 3/4-16UNF
 - (5-4) Port M2 : 3/4-16UNF
 - (5-5) Port T (return from flushing) : 3/4-16UNF
- (6) Bracket
 - (6-1) Socket : 3/4-16UNF
 - (6-2) Socket : 3/4-16UNF
 - (6-3) Socket : 3/4-16UNF
- (7) Hose : (3-5)→Hydraulic oil tank
- (8) Hose : (1-3)→Hydraulic oil tank
- (9) Hose : (4-5)→(1-4)
- (10) Hose : (4-3)←→(1-1)
- (11) Hose : (4-4)←→(1-2)
- (12) Hose : (3-1)→(4-1)
- (13) Hose : (3-3)→(4-2)
- (14) Hose : (5-3)←→(6-1)
- (15) Hose : (5-5)→(6-2)
- (16) Hose : (5-4)←→(6-3)
- (17) Hose : (3-2)←→(5-1)
- (18) Hose : (3-4)←→(5-2)
- (19) Hose : (2-3)→T branch
- (20) Hose : (6-2)→(2-4)
- (21) Hose : (6-1)←→(2-1)
- (22) Hose : (6-3)←→(2-2)

• The figures (such as 1-1 and 2-1) show each port and the arrow (←→; →) symbols show the hose connection and the direction of the flow of the oil.

(NOTICE)

• The hose adapter uses an O-ring face seal.

3-3. Hydraulic Component Specifications

3-3-1. Vibrator hydraulic motor

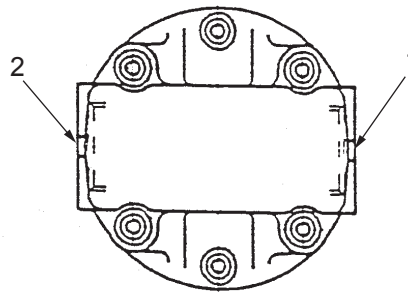
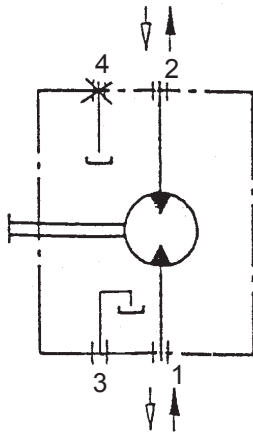
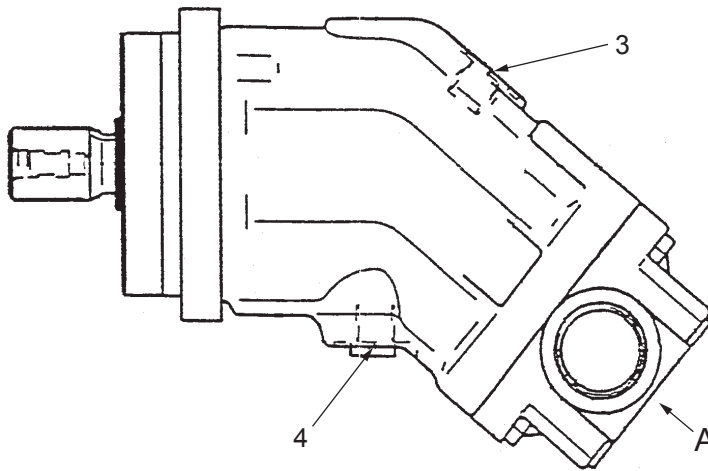
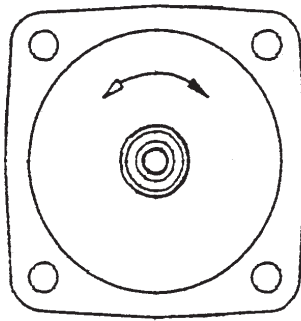

VIEW A

Hydraulic circuit diagram

Flow of oil

- A→B Clockwise rotation
- B→A Counterclockwise rotation

SW880-04009

- (1) Port A : 1 1/16-12UN-2B
- (2) Port B : 1 1/16-12UN-2B
- (3) Drain port (T1) : M12×1.5
- (4) Drain port (T2) : M12×1.5

Specifications

- Model : A2FM16/61W-VSB530-S-997-0
- Displacement : 16 cm³/rev (0.9 cu.in./rev)
- Working pressure : 22.5 MPa (3,262 psi)
- Weight : 5.4 kg (11.9 lb.)

3-3-2. Internal structure of vibrator motor

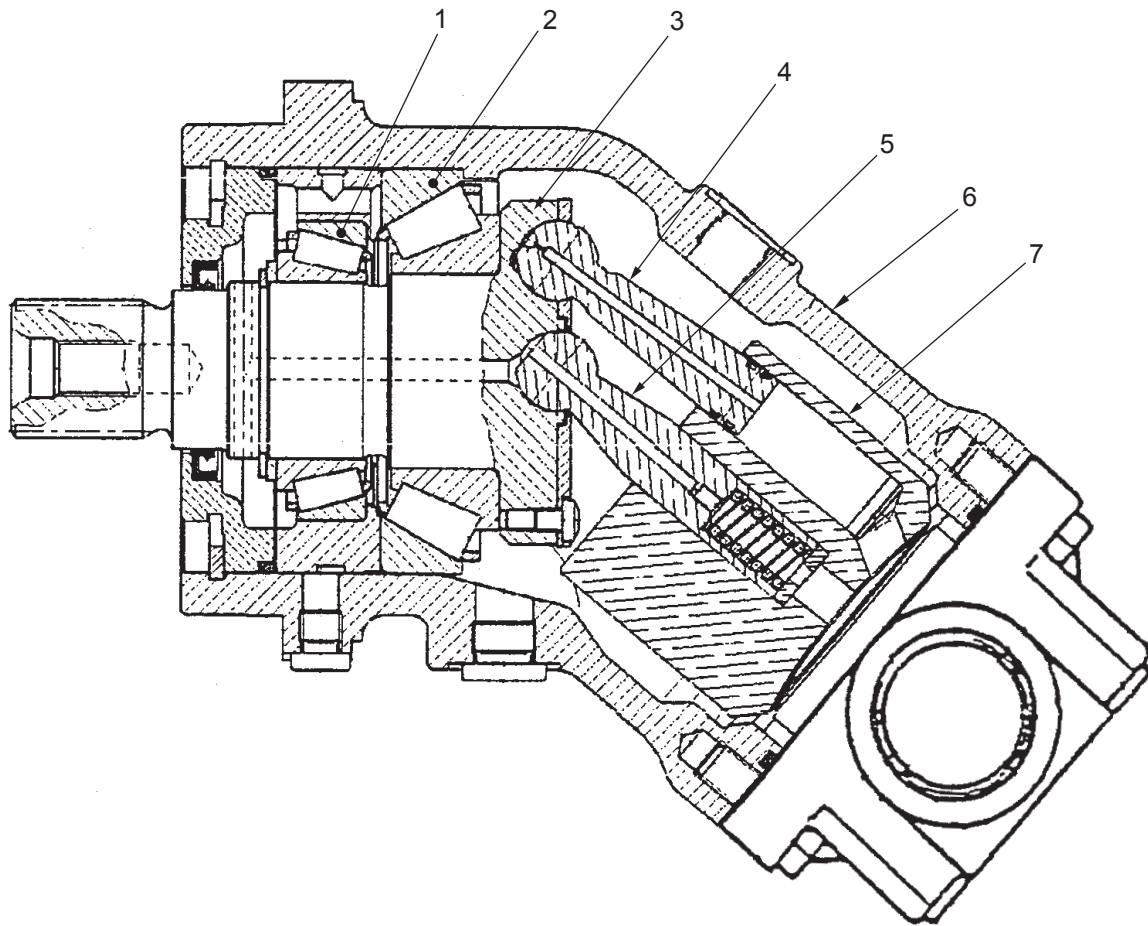

SW880-04010

- (1) Tapered roller bearing
- (2) Tapered roller bearing
- (3) Drive shaft
- (4) Piston (with piston ring)
- (5) Center pin
- (6) Housing
- (7) Cylinder

3-3-3. Valve block

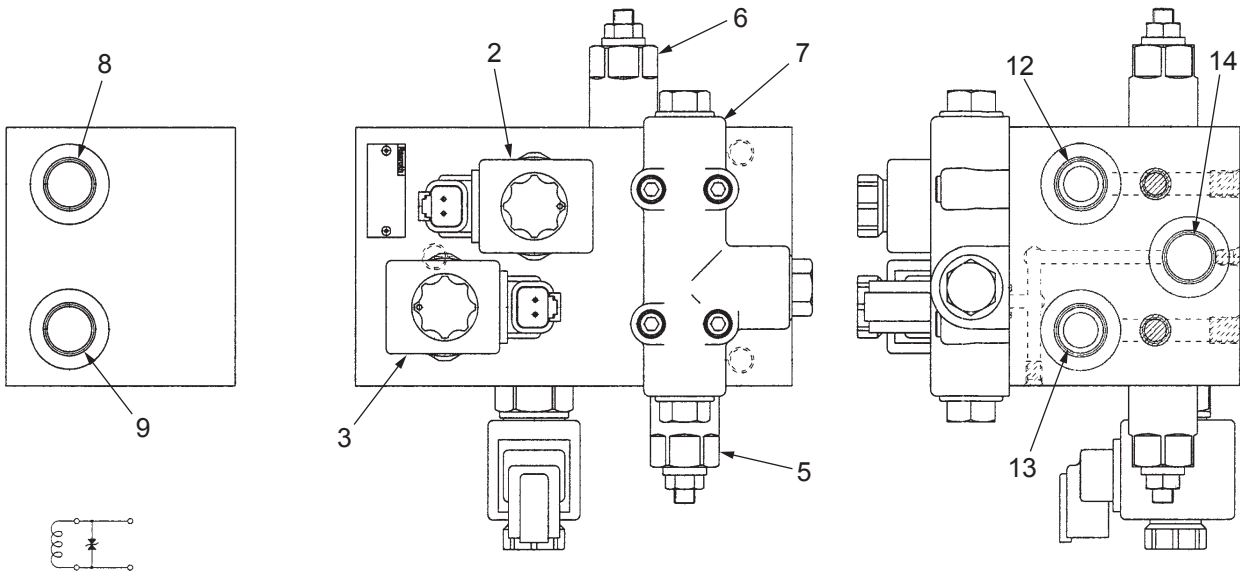

Connection diagram

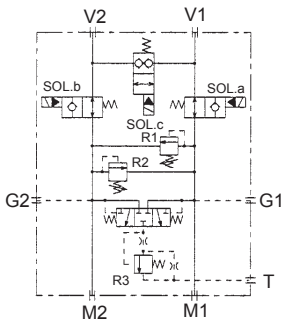

Valve block circuit diagram

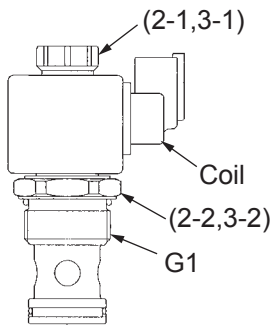
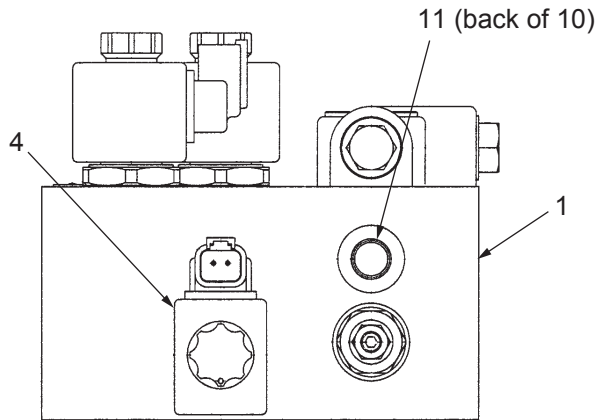

(2),(3) Solenoid valve (a, b)

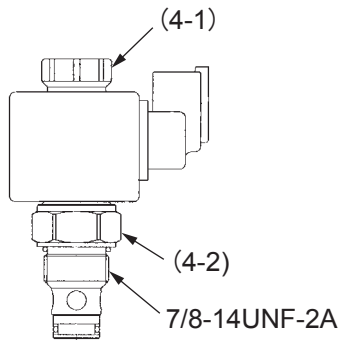

(4) Bypass valve

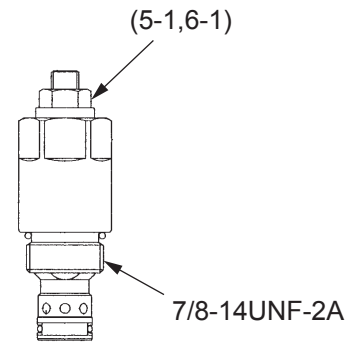

(5),(6) Relief valve (R1, R2)

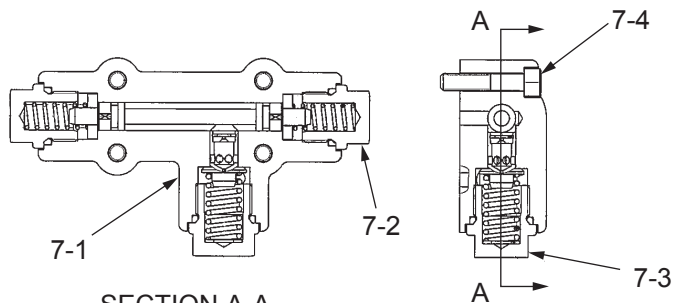

(7) Flushing valve

- (1) Body
- (2) Solenoid poppet valve (a)
- (3) Solenoid poppet valve (b)
- (4) Solenoid poppet valve (for bypass valve)
- (5) High-pressure relief valve (port relief valve) R1
- (6) High-pressure relief valve (port relief valve) R2
- (7) Flushing valve
 - (7-1) Body
 - (7-2) Plug
 - (7-3) Plug
 - (7-4) Hexagon socket head bolt : M6×30
- (8) Port V1 : 3/4-16UNF
- (9) Port V2 : 3/4-16UNF
- (10) Port G1 (low amplitude) : 9/16-18UNF
- (11) Port G2 (high amplitude) : 9/16-18UNF
- (12) Port M1 : 3/4-16UNF
- (13) Port M2 : 3/4-16UNF
- (14) Port T : 3/4-16UNF



- (2-1) Nut : 3.5 N·m (2.6 lbf·ft)
- (2-2) Nut : 90 N·m (66 lbf·ft)
- (3-1) Nut : 3.5 N·m (2.6 lbf·ft)
- (3-2) Nut : 90 N·m (66 lbf·ft)
- (4-1) Nut : 3.5 N·m (2.6 lbf·ft)
- (4-2) Nut : 50 N·m (37 lbf·ft)
- (5) High-pressure relief valve (R1) : 44 N·m (32 lbf·ft)
 - (5-1) Nut : 13.5 N·m (10 lbf·ft)
- (6) High-pressure relief valve (R2) : 44 N·m (32 lbf·ft)
 - (6-2) Nut : 13.5 N·m (10 lbf·ft)

Specifications

- Rated pressure : 35 MPa (ports V, M and G) (5,075 psi)
- Rated flow : 0.5 MPa (port T) (72 psi)
- Relief valve setting pressure : 70 L/min (18.5 gal./min)
- Relief valve setting pressure : 34 MPa (R1, R2) (4,930 psi)
- Relief valve setting pressure : 1.3 MPa (R3) (145 psi)
- Flushing flow rate : 9 ± 1 L/min (2.4 gal. ± 0.3 gal.)
- Weight : 13 kg (28.7 lb.)

4. STEERING SYSTEM

4-1. Steering Hydraulic Piping

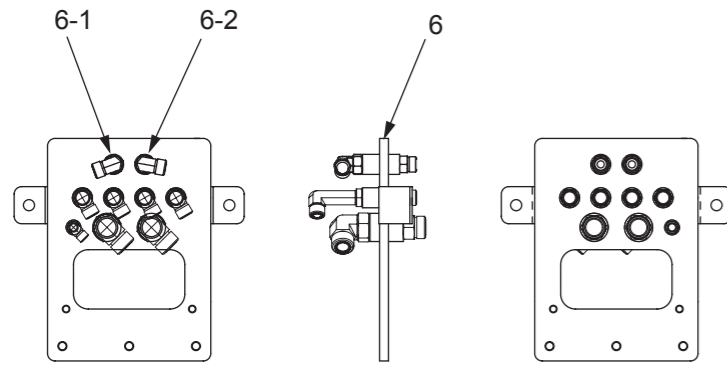

DETAIL A

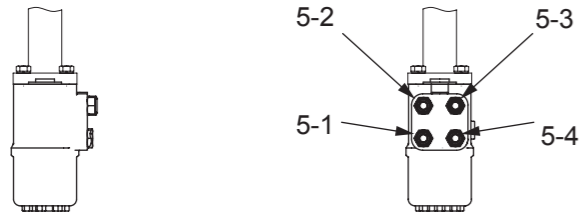

DETAIL B

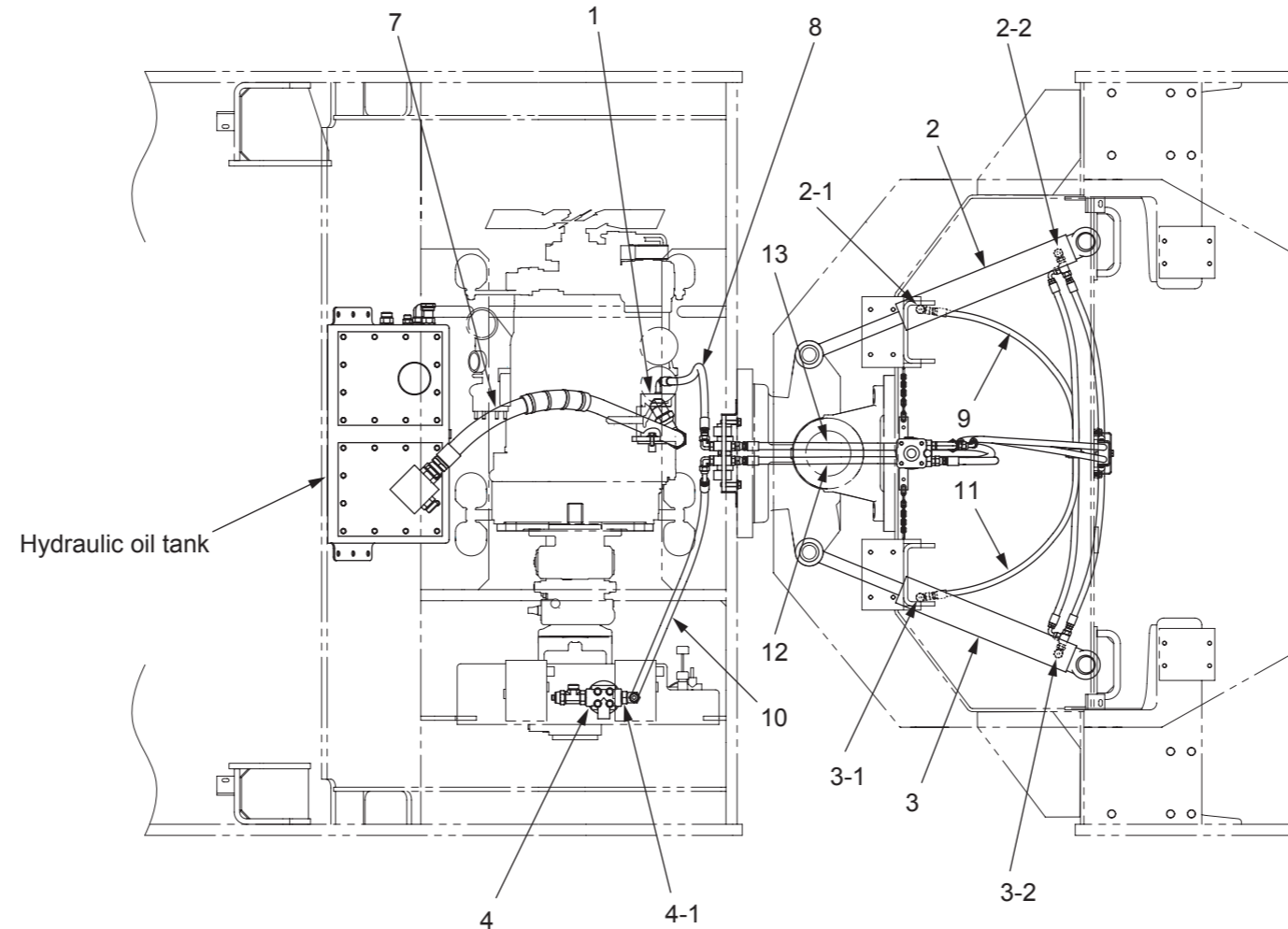

- (1) Steering pump
(1-1) Suction port : 1 5/16-12UN
(1-2) Discharge port : 7/8-14UNF
- (2) Power cylinder (R)
(2-1) Port R1 : 2 3/4-16UNF
(2-2) Port R2 : 2 3/4-16UNF
- (3) Power cylinder (L)
(3-1) Port L1 : 2 3/4-16UNF
(3-2) Port L2 : 2 3/4-16UNF
- (4) Line filter
(4-1) Filter inlet port : G3/4"
- (5) Orbitrol
(5-1) Port P : 3/4-16UNF
(5-2) Port T : 3/4-16UNF
(5-3) Port L : 3/4-16UNF
(5-4) Port R : 3/4-16UNF
- (6) Bracket
(6-1) Socket : 3/4-16UNF
(6-2) Socket : 3/4-16UNF
- (7) Hose : Hydraulic oil tank→(1-1)
- (8) Hose : (1-2)→(6-1)
- (9) Hose : (2-1)↔(3-2)
- (10) Hose : (6-2)→(4-1)
- (11) Hose : (3-1)↔(2-2)
- (12) Hose : (5-2)→(6-2)
- (13) Hose : (6-1)→(5-1)
- (14) Hose : (5-3)↔(2-2)
- (15) Hose : (5-4)↔(3-2)

- The figures (such as 1-1 and 2-1) show each port and the arrow (↔; →) symbols show the hose connection and the direction of the flow of the oil.

(NOTICE)

- The hose adapter uses an O-ring face seal.

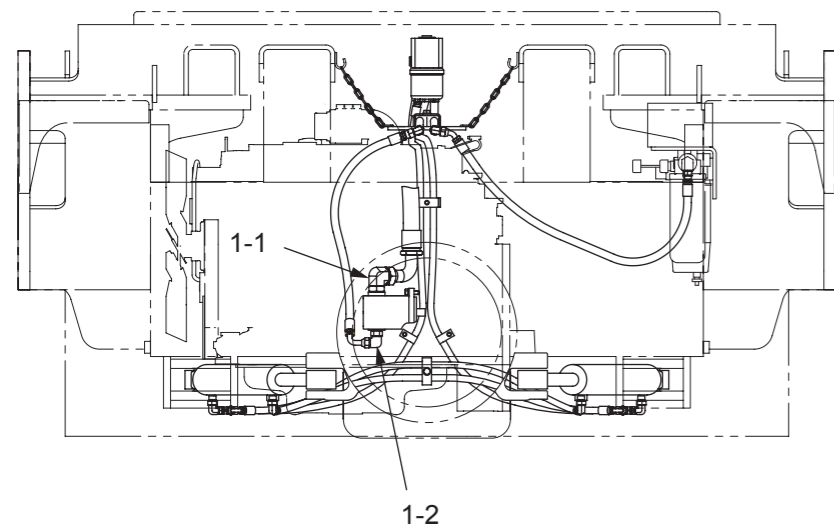

SECTION C-C

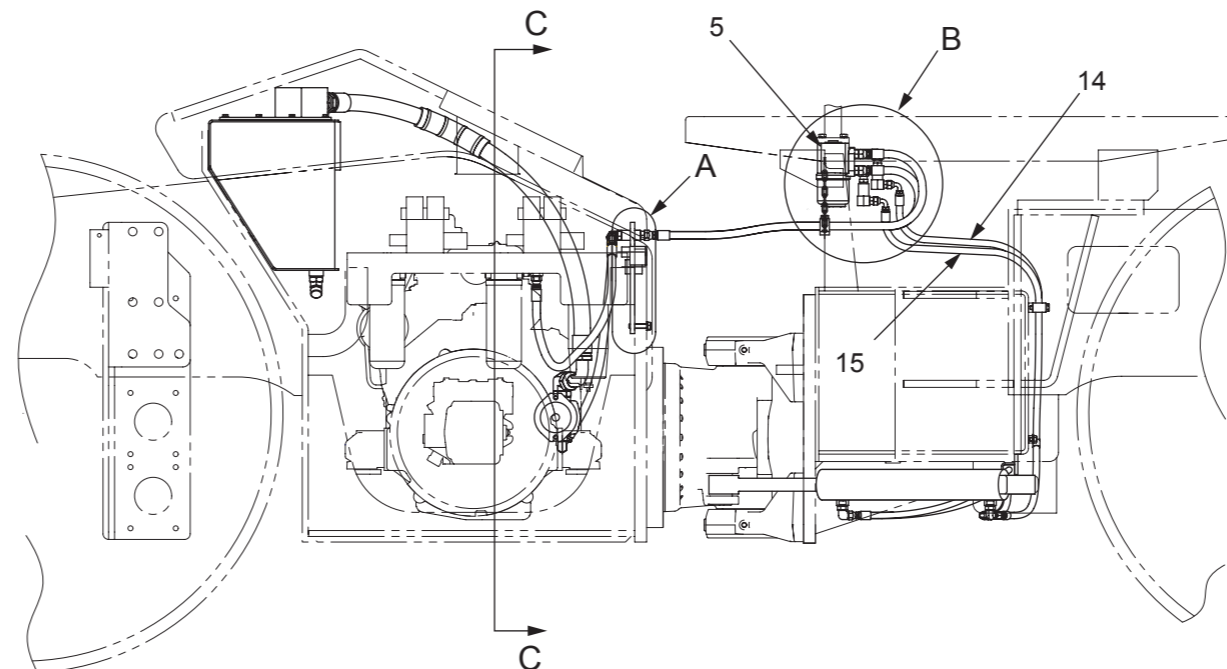

4-1-1. Steering pump

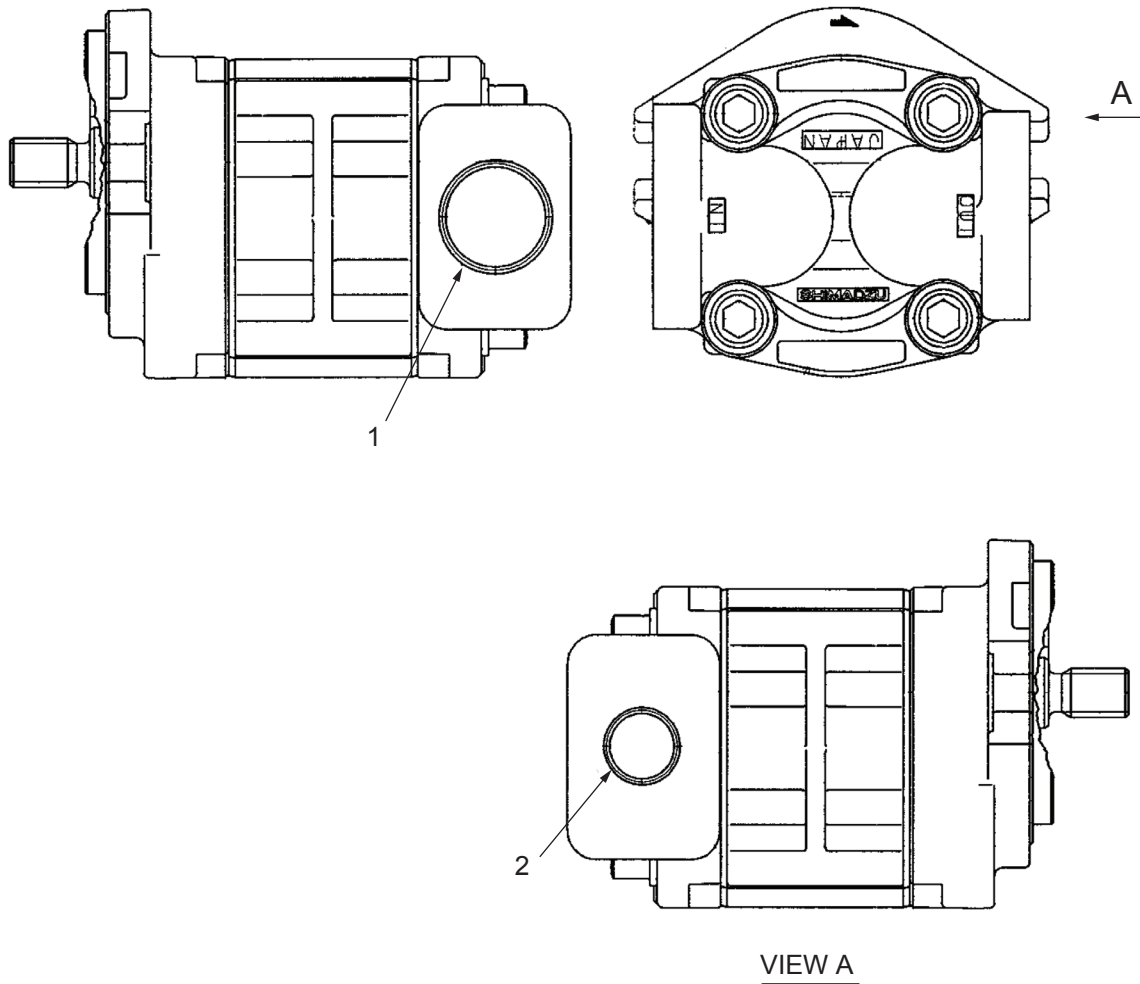

SW880-04013

- (1) Suction port : 1 5/16-12UN
 (2) Discharge port : 7/8-14UNF

Specifications

- Model : SGP1A20F3H9-L
 - Displacement : 20.4 cm³/rev (1.2 cu.in./rev)
 - Rated pressure : 19.7 MPa (2,857 psi)
- Steering pump weight : 3.5 kg (7.7 lb.)

4-1-2. Internal structure of steering pump

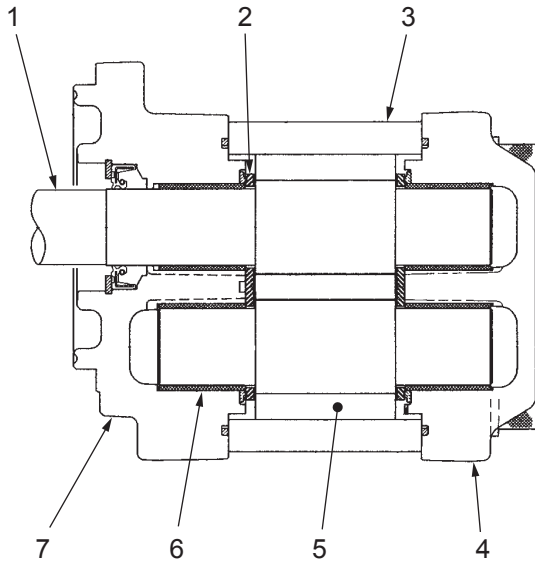

SW880-04014

- (1) Gear drive
- (2) Side plate
- (3) Body
- (4) Cover

- (5) Gear driven
- (6) Bushing
- (7) Cover

4-2. Steering Wheel

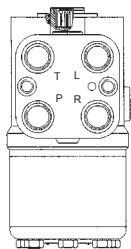
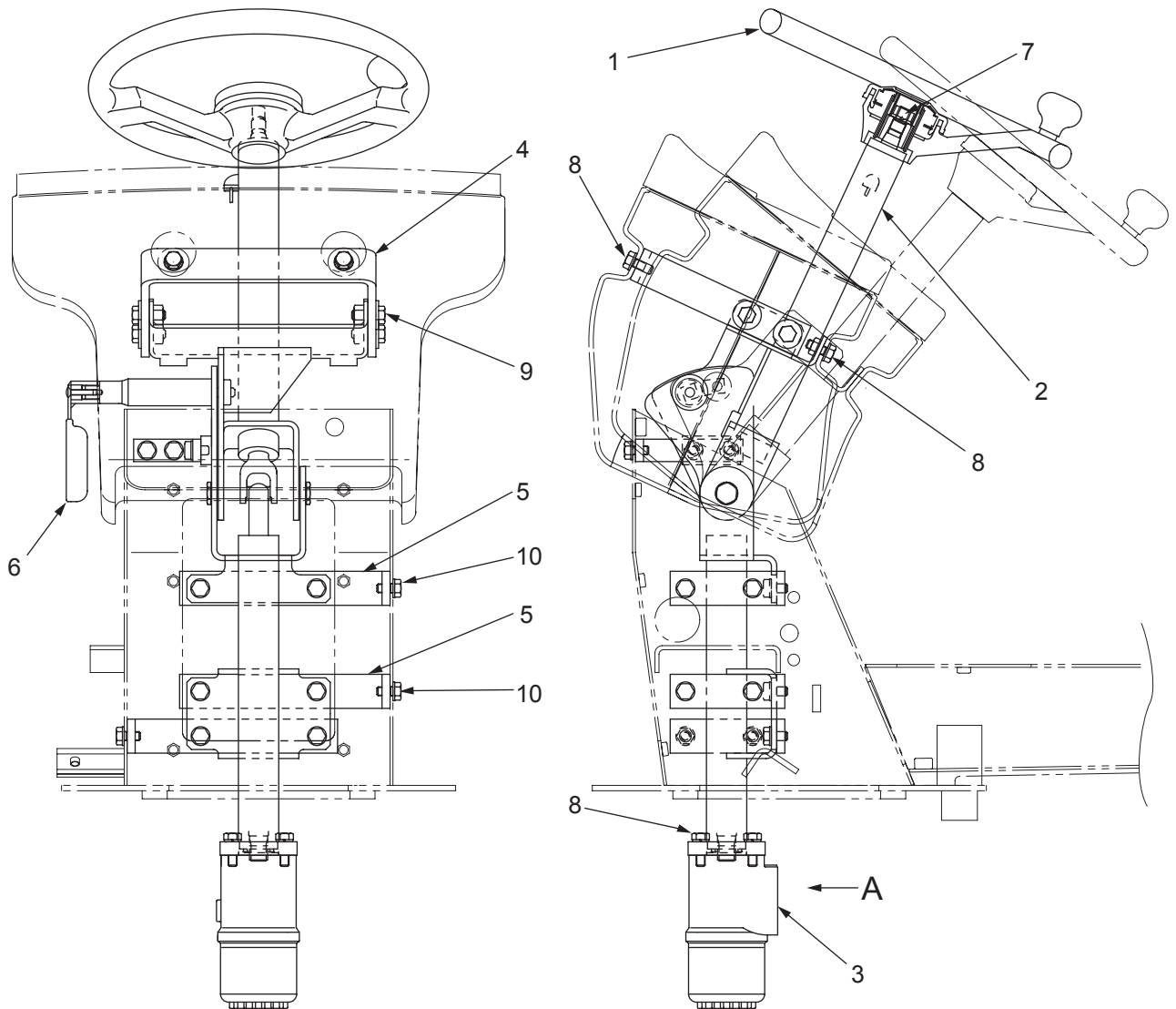

VIEW A

0568-32801-0-20070-0

- (1) Steering wheel
- (2) Column shaft
- (3) Orbitrol
- (4) Bracket
- (5) Bracket
- (6) Tilt lock handle



- (7) Nut M12 P=1.25 : 88 N·m (65 lbf-ft)
- (8) Bolt M10×25 : 49 N·m (36 lbf-ft)
- (9) Bolt M10×30 : 49 N·m (36 lbf-ft)
- (10) Bolt M10×20 : 49 N·m (36 lbf-ft)

• Steering wheel assembly weight : 28 kg (62 lbs.)

4-2-1. Steering valve (orbitrol)

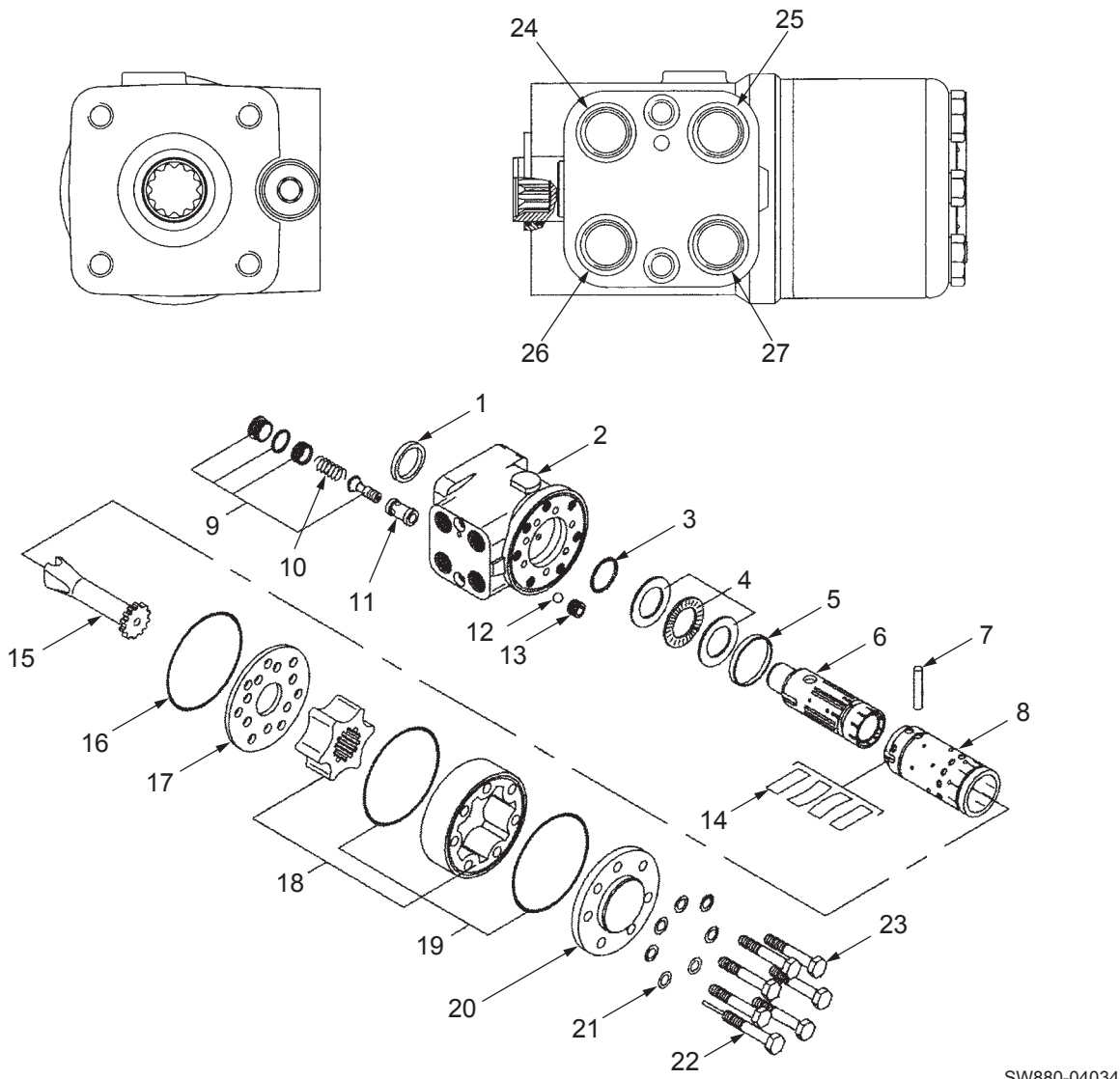

SW880-04034

- | | | |
|----------------------|--------------|-------------------------|
| (1) Dust seal | (10) Spring | (19) O-ring |
| (2) Housing | (11) Seat | (20) Cover |
| (3) O-ring | (12) Ball | (21) Washer |
| (4) Bearing assembly | (13) Bushing | (22) Screw pin |
| (5) Ring | (14) Spring | (23) Screw |
| (6) Sleeve | (15) Shaft | (24) Port L : 3/4-16UNF |
| (7) Pin | (16) O-ring | (25) Port R : 3/4-16UNF |
| (8) Spool | (17) Plate | (26) Port T : 3/4-16UNF |
| (9) Relief valve | (18) Gerotor | (27) Port P : 3/4-16UNF |

Specifications

- Model : OSPC 400 ON
- Displacement : 400 cm³/rev (24.4 cu.in./rev)
- Relief valve setting pressure : 15.0 MPa (2,175 psi)
- Weight : 8 kg (18 lb.)

4-3. Steering Cylinder

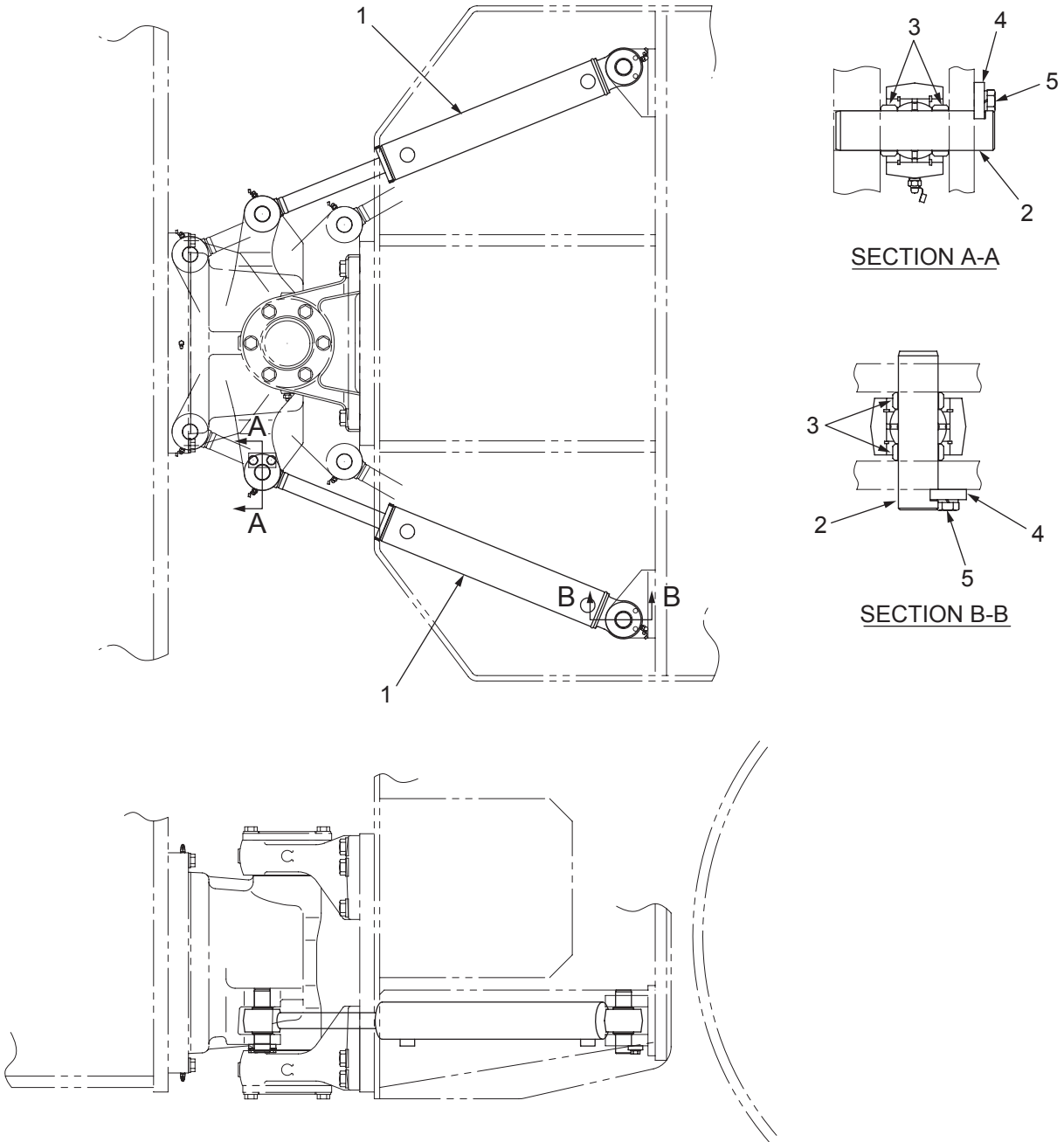

(1) Steering cylinder

(2) Pin

(3) Collar

(4) Plate



(5) Bolt M10×25 : 49 N·m (36 lbf·ft)

0568-32802-0-10111-0

4-3-1. Internal structure of steering cylinder

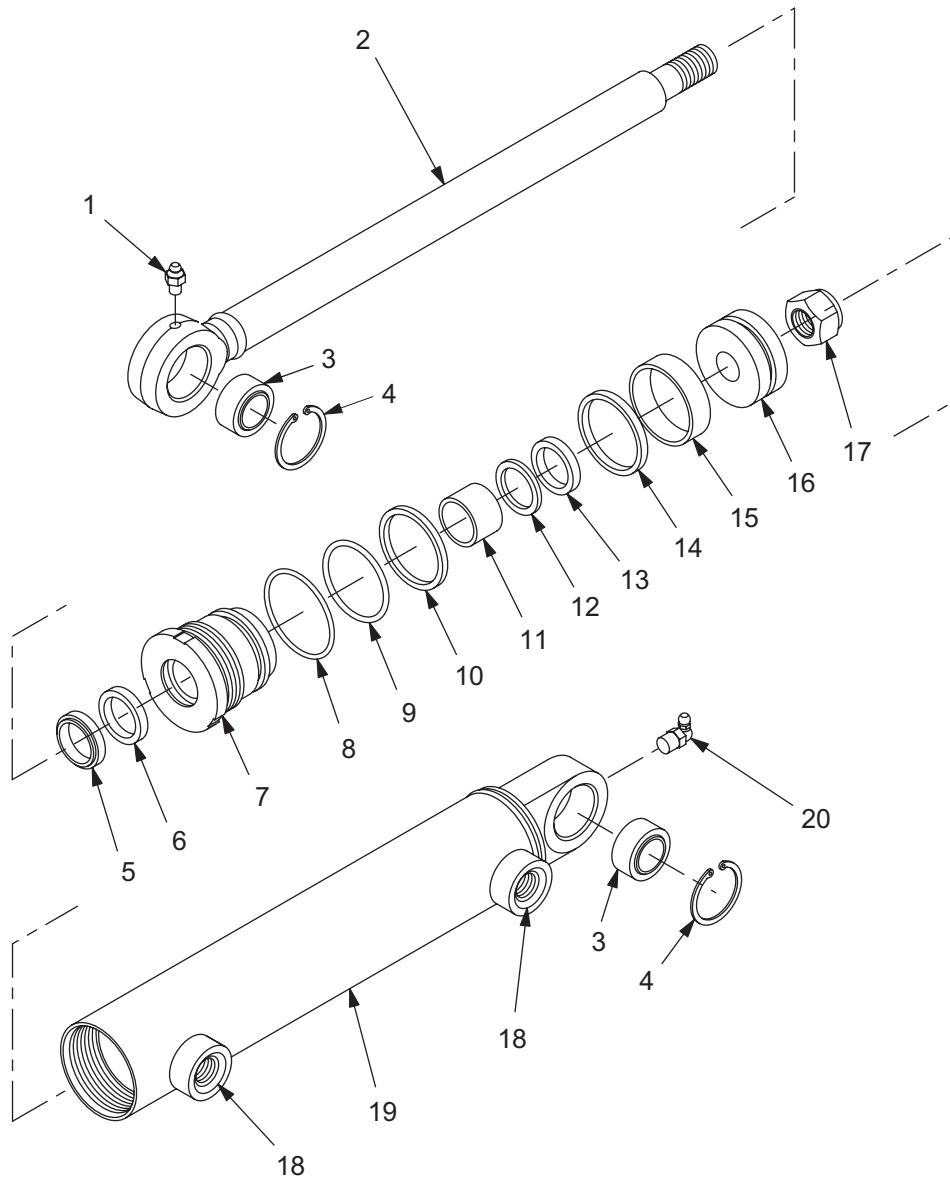

- | | | | |
|-----------------------|--------|--------------------|---------------|
| (1) Grease nipple | : R1/8 | (11) Bushing | |
| (2) Rod | | (12) Packing | |
| (3) Spherical bearing | | (13) Backup ring | |
| (4) Snap ring | | (14) Slip seal | |
| (5) Dust seal | | (15) Ring wear | |
| (6) Stopper | | (16) Piston | |
| (7) Rod cap | | (17) Nylon nut | : M24 |
| (8) O-ring | : G-70 | (18) O-ring port | : 2 3/4-16UNF |
| (9) O-ring | : G-65 | (19) Tube | |
| (10) Backup ring | | (20) Grease nipple | : R1/8 |

Specifications

- Maximum working pressure : 17.2 MPa (2,488 psi)
- Stroke : 380 mm (15 in.)
- Weight : 21 kg (46 lb.)



- (17) Nylon nut : M24 382 – 559 N·m
(282 – 412 lbf·ft)

4-4. Frame (Center Pin)

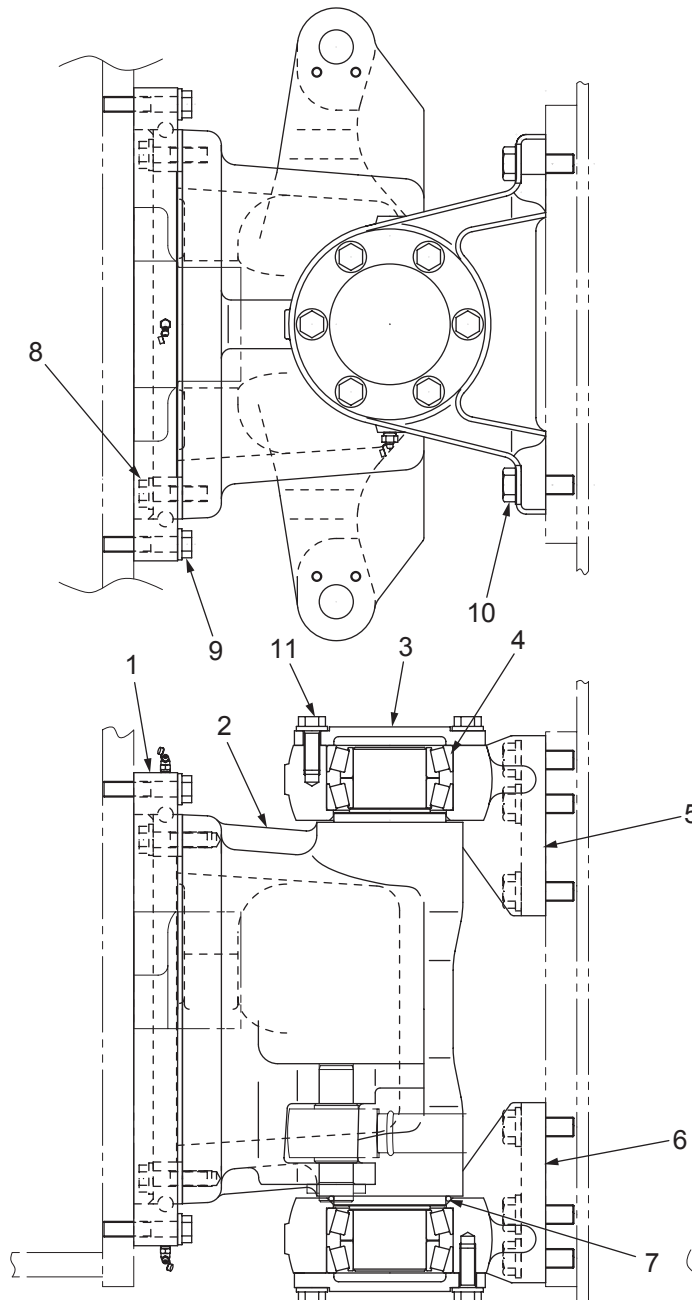

0568-61802-0-10110-0

- (1) Swing bearing
- (2) Yoke
- (3) Cover
- (4) Roller bearing
- (5) Bracket (upper)
- (6) Bracket (lower)
- (7) O-ring : P-112



- (8) Bolt M16×60 : 265 N·m (195 lbf·ft)
- (9) Bolt M16×80 : 265 N·m (195 lbf·ft)
- (10) Bolt M20×60 : 539 N·m (398 lbf·ft)
- (11) Bolt M16×45 : 265 N·m (195 lbf·ft)

- Center pin assembly weight : 208 kg (459 lbs.)

ELECTRICAL SYSTEM

1. GENERAL SYSTEM CIRCUIT DIAGRAM

1-1. Electrical Wiring Diagram

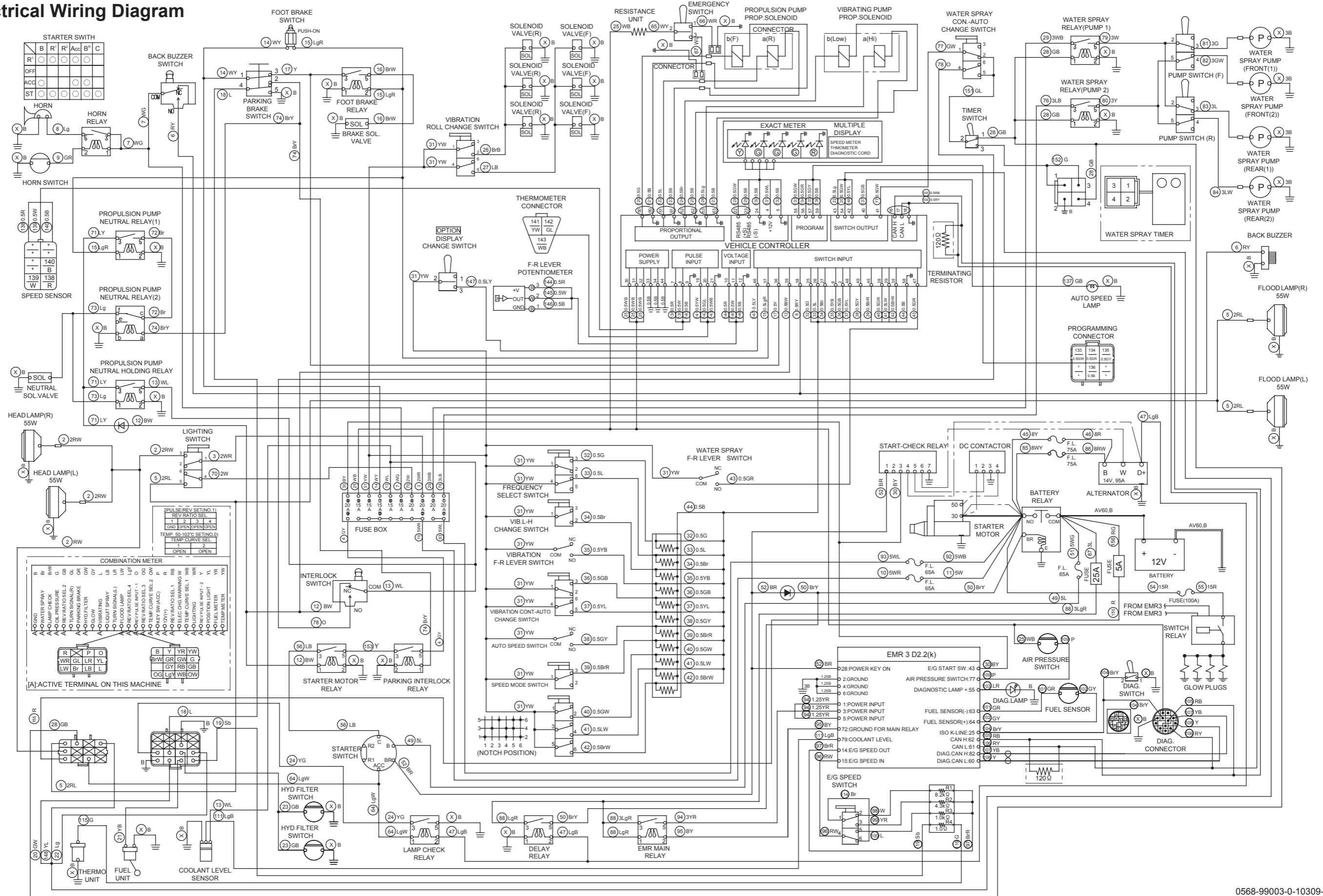

1-1-1. Engine-related electrical wiring diagram

Start switch position \ Terminal	B	R1	R2	ACC	BR	C
R1	○	○	○	○	○	
OFF						
ACC	○			○	○	
ST	○	○	○	○	○	○

Starter switch internal connection

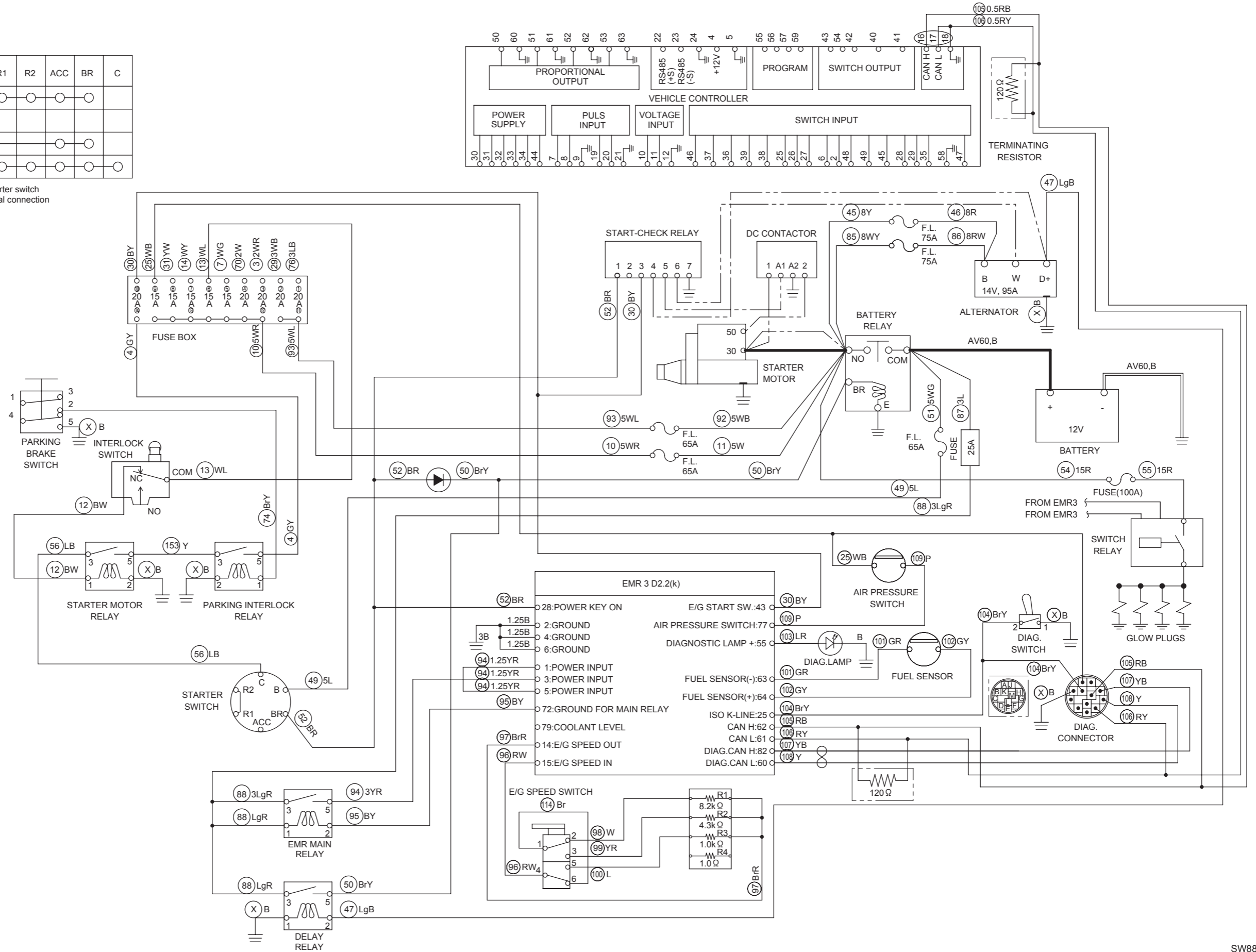

1-1-2. Vehicle-related electrical wiring diagram (vehicle control unit)

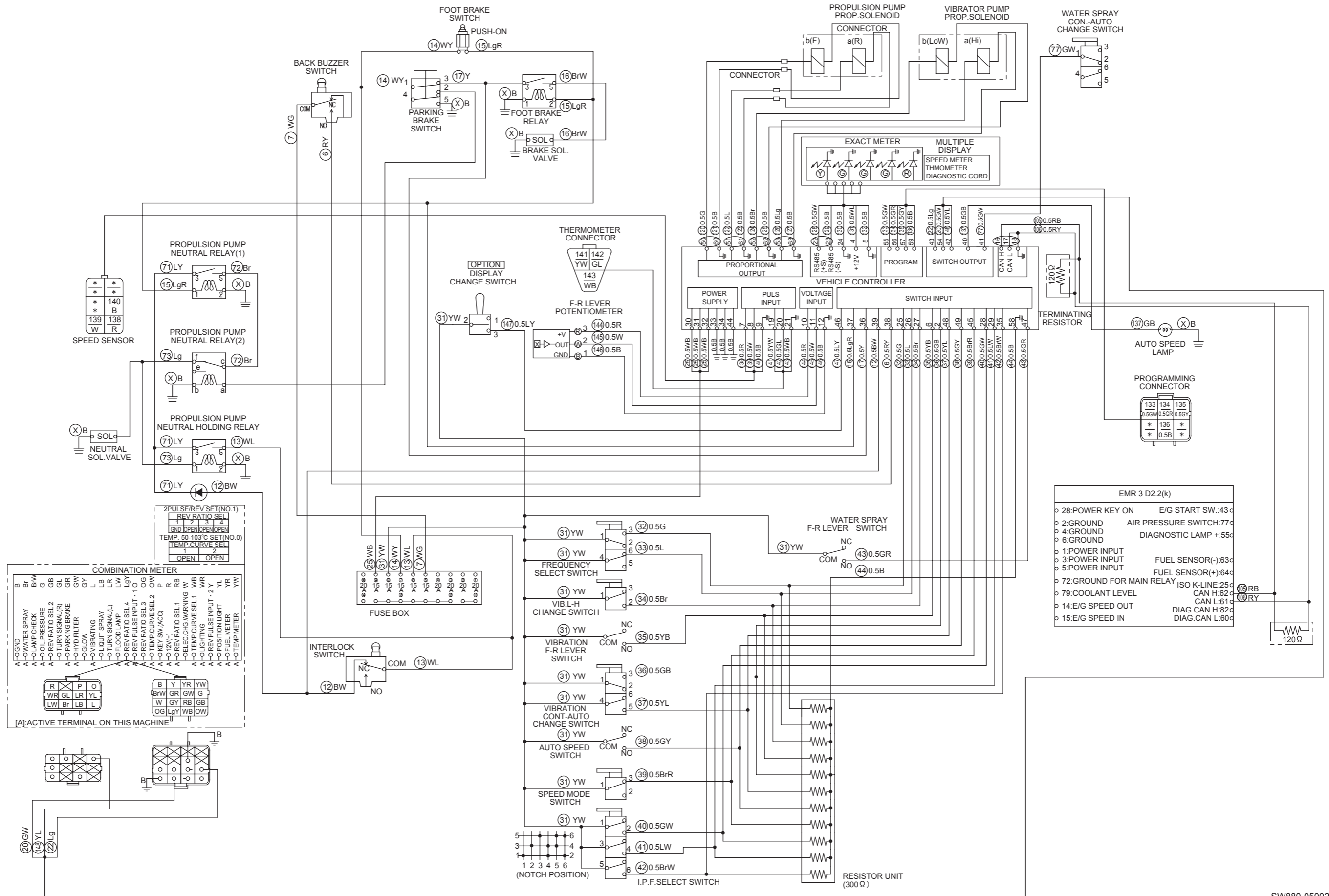

1-1-3. Vehicle-related electrical wiring diagram

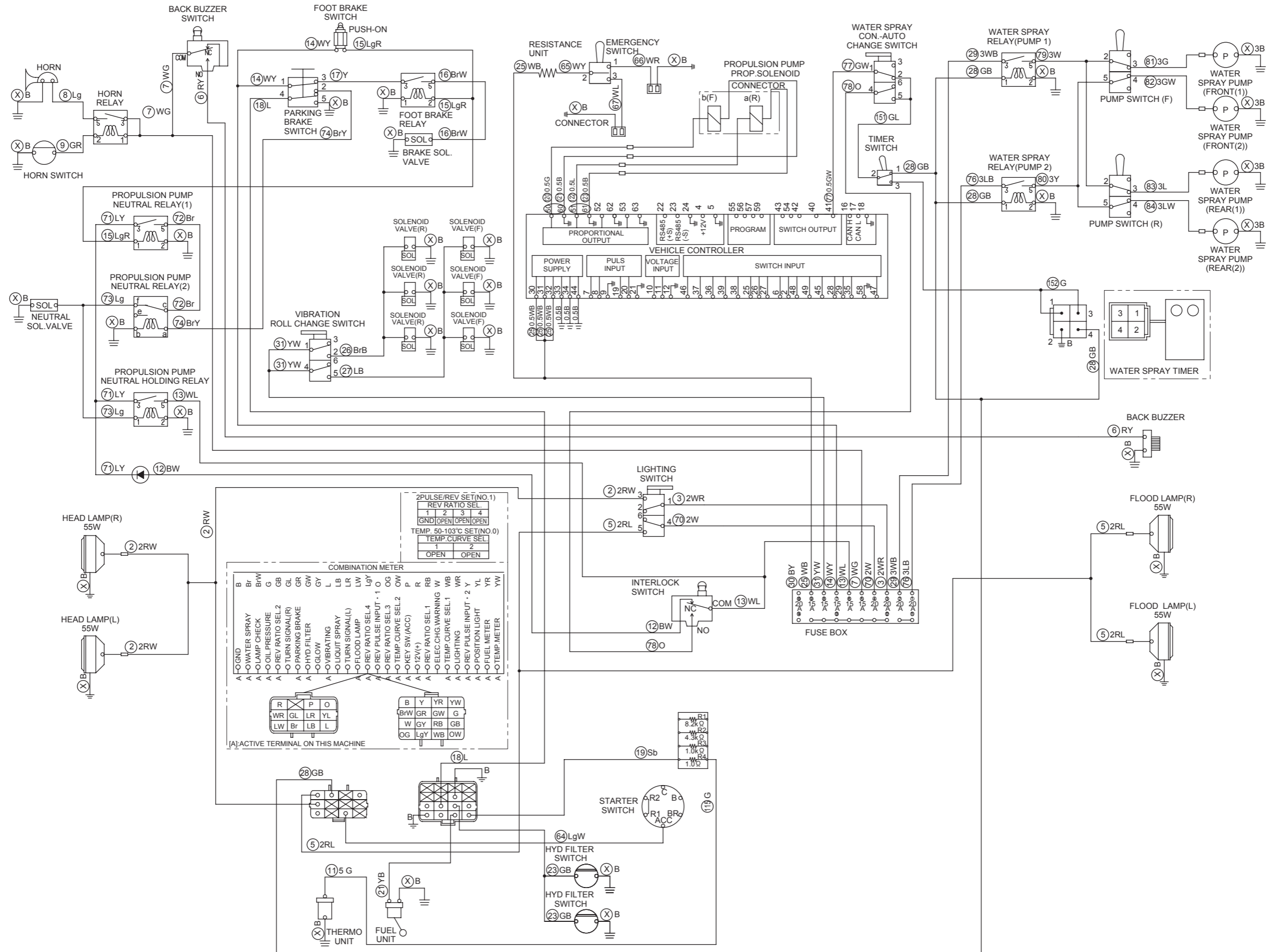

2. ELECTRICAL COMPONENTS

2-1. Electrical Component Layout (1)

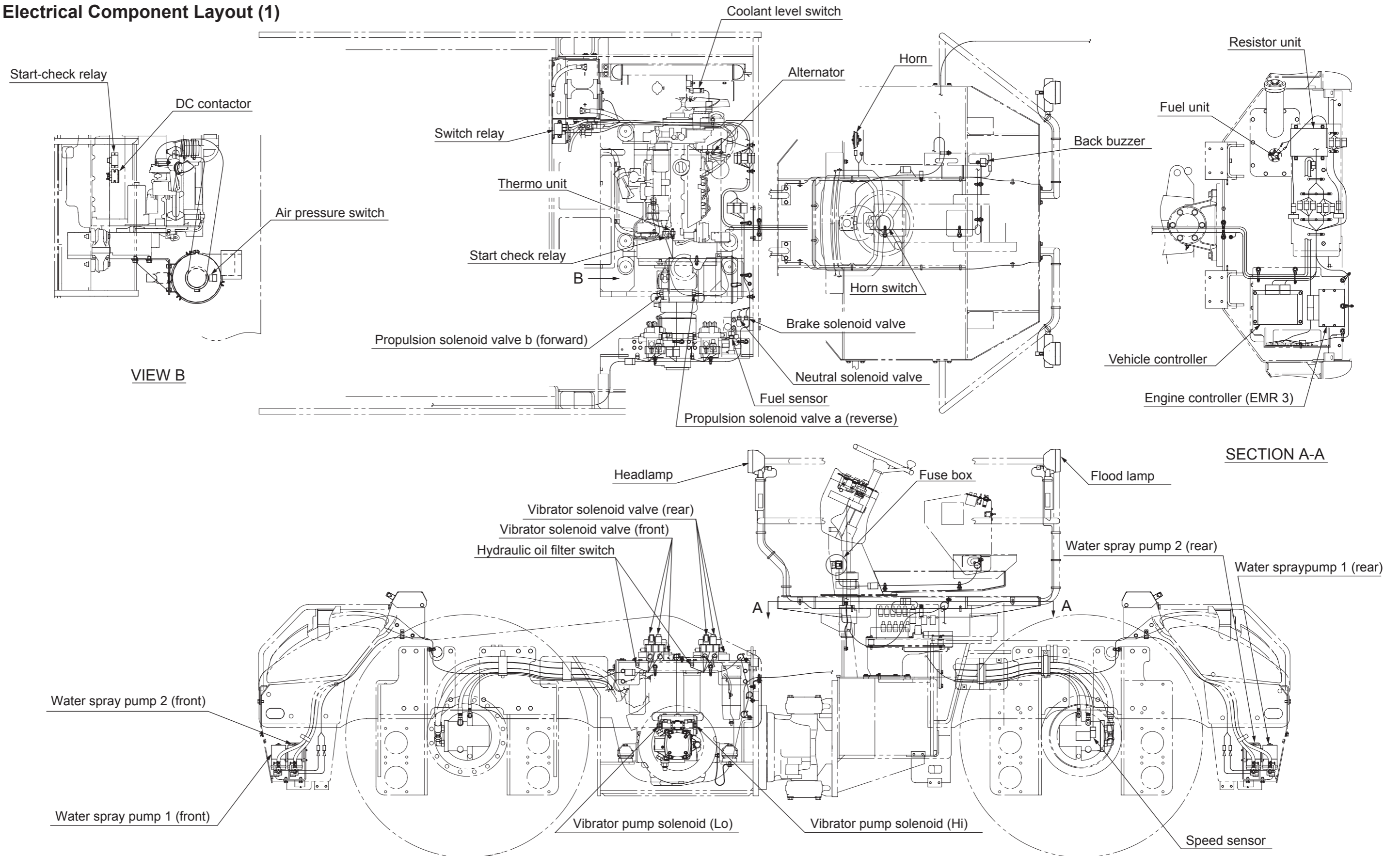

2-2. Electrical Component Layout (2)

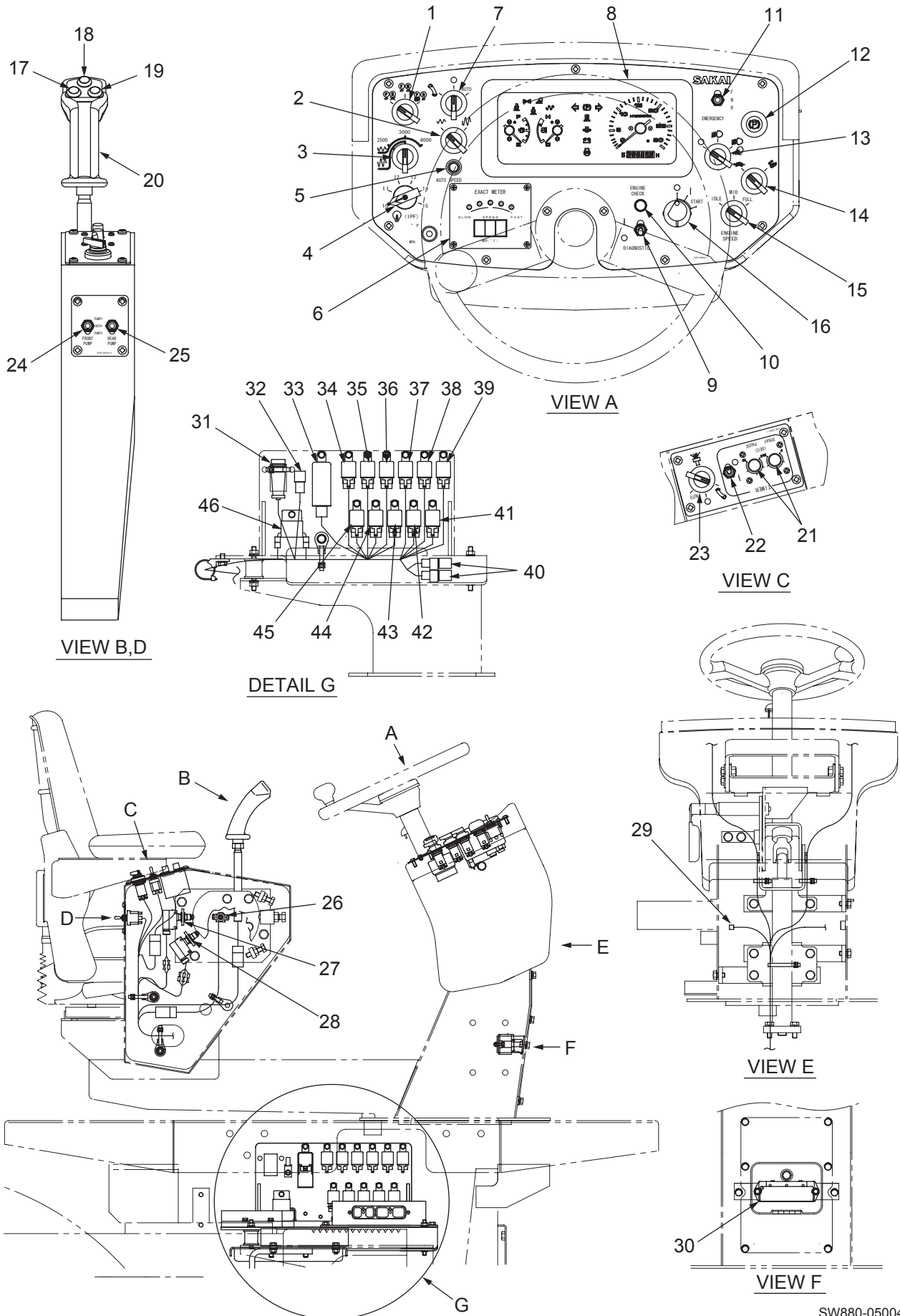

- (1) Vibratory drum selector switch
- (2) High/low-vibration selector switch
- (3) Vibration frequency selector switch
- (4) IPF selector switch
- (5) Automatic speed indicator lamp
- (6) Exact meter
- (7) Vibration mode (continuous/automatic) selector switch
- (8) Combination meter
- (9) Engine diagnostic switch
- (10) Engine check lamp
- (11) Emergency propulsion switch
- (12) Parking brake switch
- (13) Lighting switch
- (14) Speed switch
- (15) Throttle switch
- (16) Starter switch
- (17) Vibrator switch
- (18) Automatic speed setting switch
- (19) Water spray switch
- (20) Forward-reverse lever
- (21) Water spray timer
- (22) Timer switch
- (23) Water spray mode (continuous/automatic) selector switch
- (24) Front water spray pump selector switch
- (25) Rear water spray pump selector switch
- (26) Potentiometer
- (27) Forward-reverse lever switch
- (28) Back buzzer switch
- (29) Foot brake switch
- (30) Fuse box
- (31) Diagnostic connector
- (32) Programming connector
- (33) Neutral relay
- (34) Parking interlock relay
- (35) Starter motor relay
- (36) Lamp check relay
- (37) Delay relay
- (38) EMR main relay
- (39) Foot brake relay
- (40) Diode
- (41) Water spray 2 relay
- (42) Water spray 1 relay
- (43) Horn relay
- (44) Neutral holding relay
- (45) Neutral relay
- (46) Resistor unit

2-3. Battery Layout

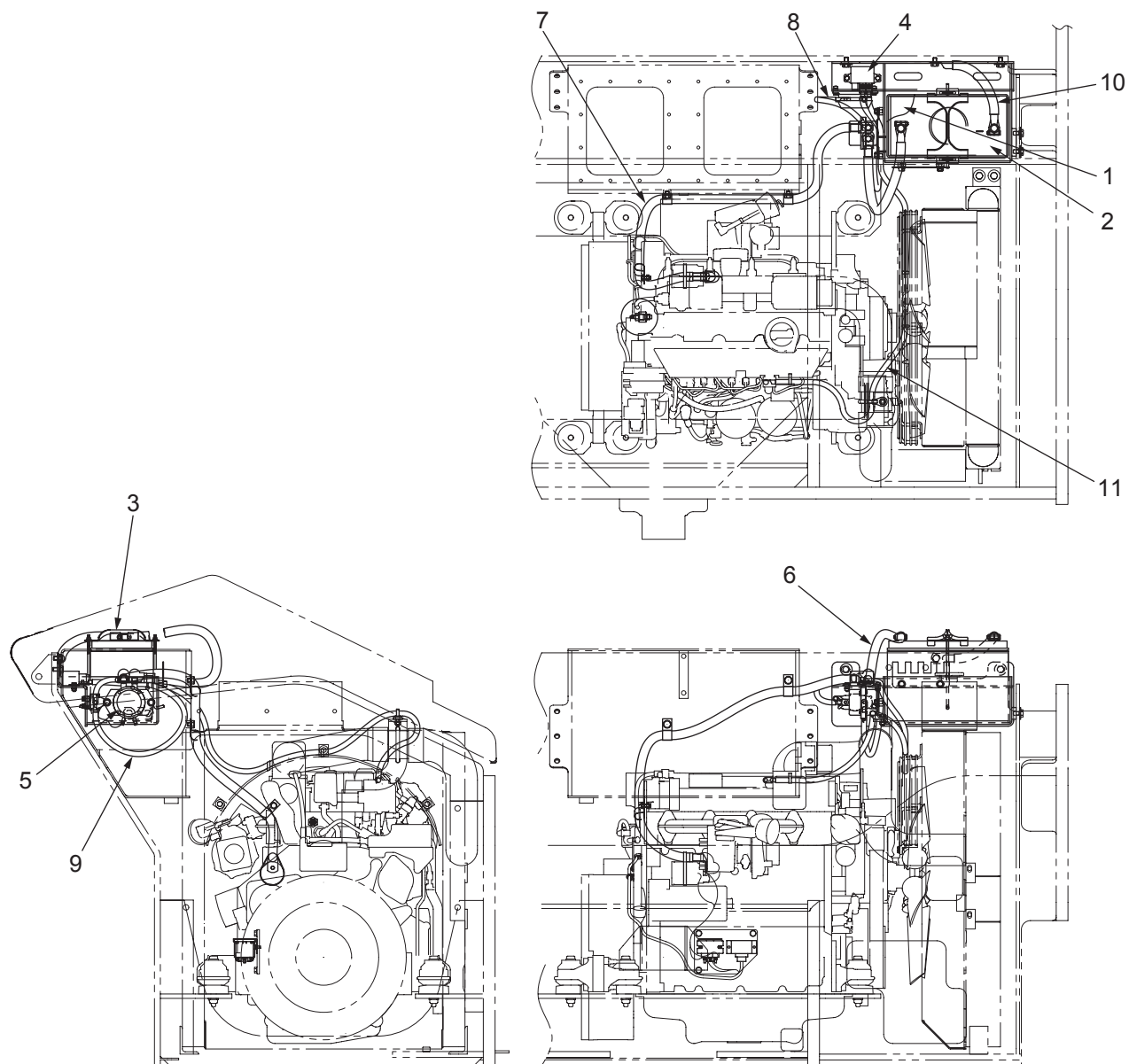

0568-09803-10162-B

- | | |
|-------------------|--|
| (1) Cushion | (6) Battery code: L = 480 mm (18.9 in.) |
| (2) Battery | (7) Battery code: L = 1,400 mm (55.1 in.) |
| (3) Support | (8) Battery code: L = 400 mm (15.7 in.) |
| (4) Switch relay | (9) Battery code: L = 550 mm (21.7 in.) |
| (5) Battery relay | (10) Battery code: L = 300 mm (11.8 in.) |
| | (11) Battery code: L = 1,550 mm (61.0 in.) |

3. ELECTRICAL COMPONENT SPECIFICATIONS

3-1. Fuse Box

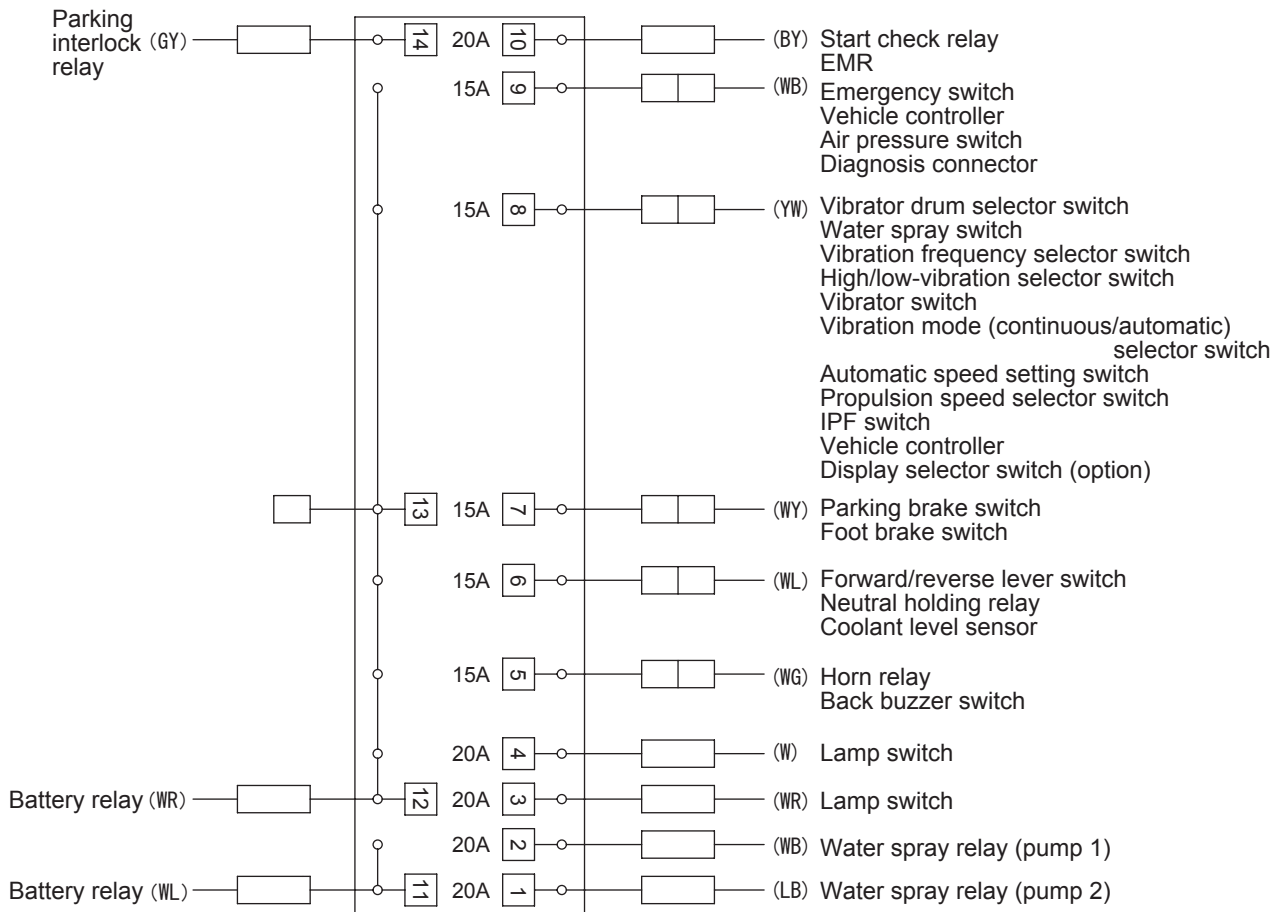
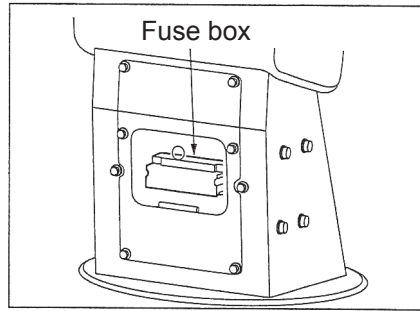

Fuse box

SW880-05005

Harness color codes

- | | |
|--------------------------|--------------------------|
| W : White | LB : Blue/Black stripe |
| WR : White/Red stripe | BY : Black/Yellow stripe |
| WL : White/Blue stripe | GY : Green/Yellow stripe |
| WB : White/Black stripe | |
| WY : White/Yellow stripe | |
| WG : White/Green stripe | |

3-2. Vehicle Control (V/C)

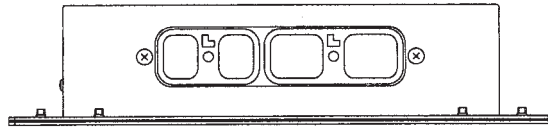
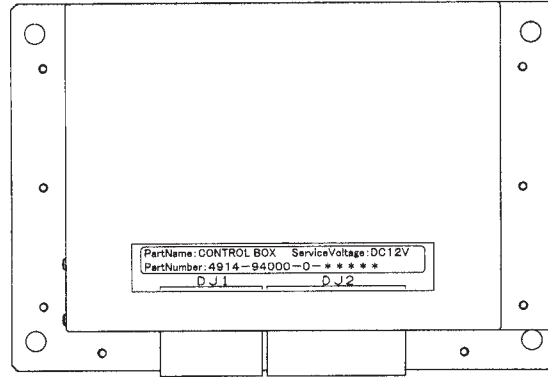

Receptacle : DRC23-64PAA

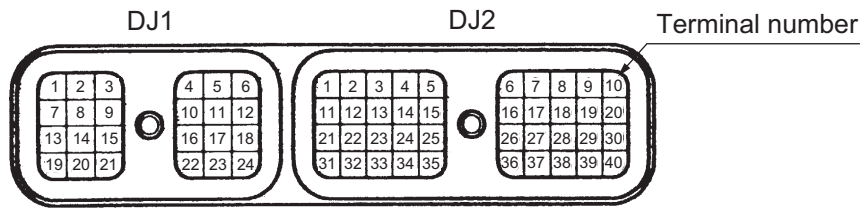

Harness side

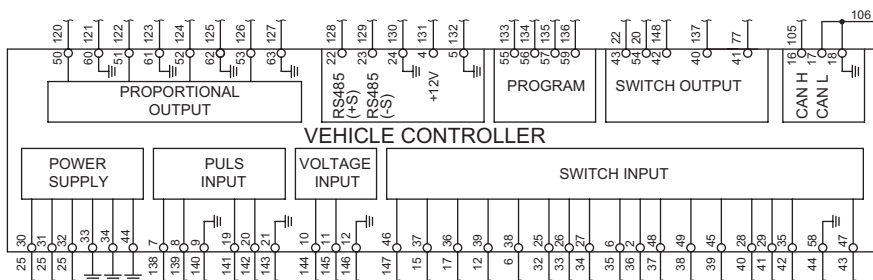
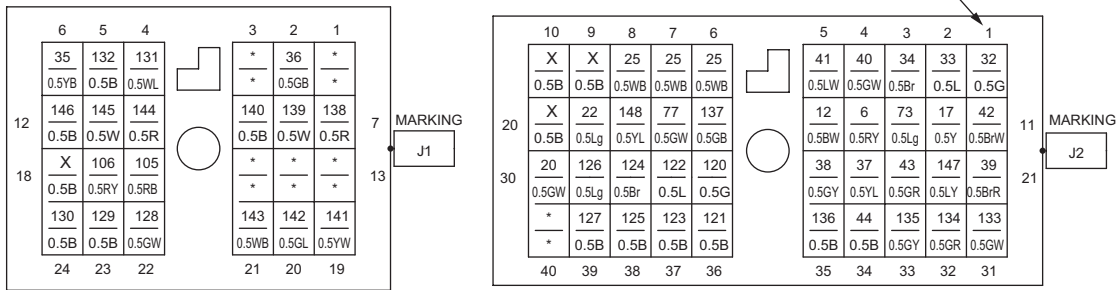

Wire color and number (Refer to "1-4 Wire Color Code and Number" of TROUBLESHOOTING.)

- The arrangement of connector terminals shown below is that of connecting surfaces on the connector side.

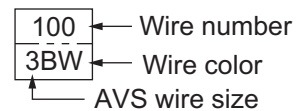

3-3. Control Box (EMR 3)

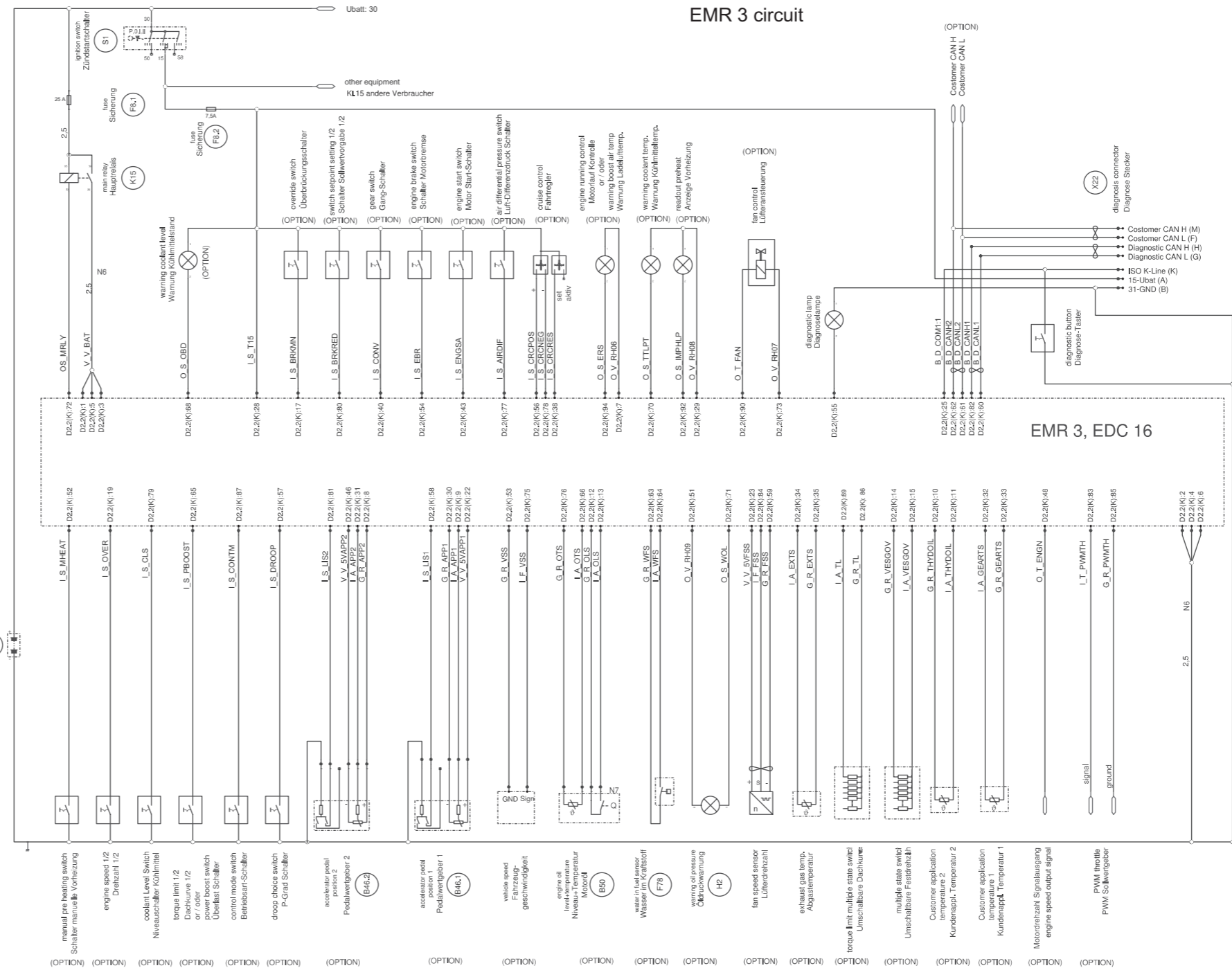
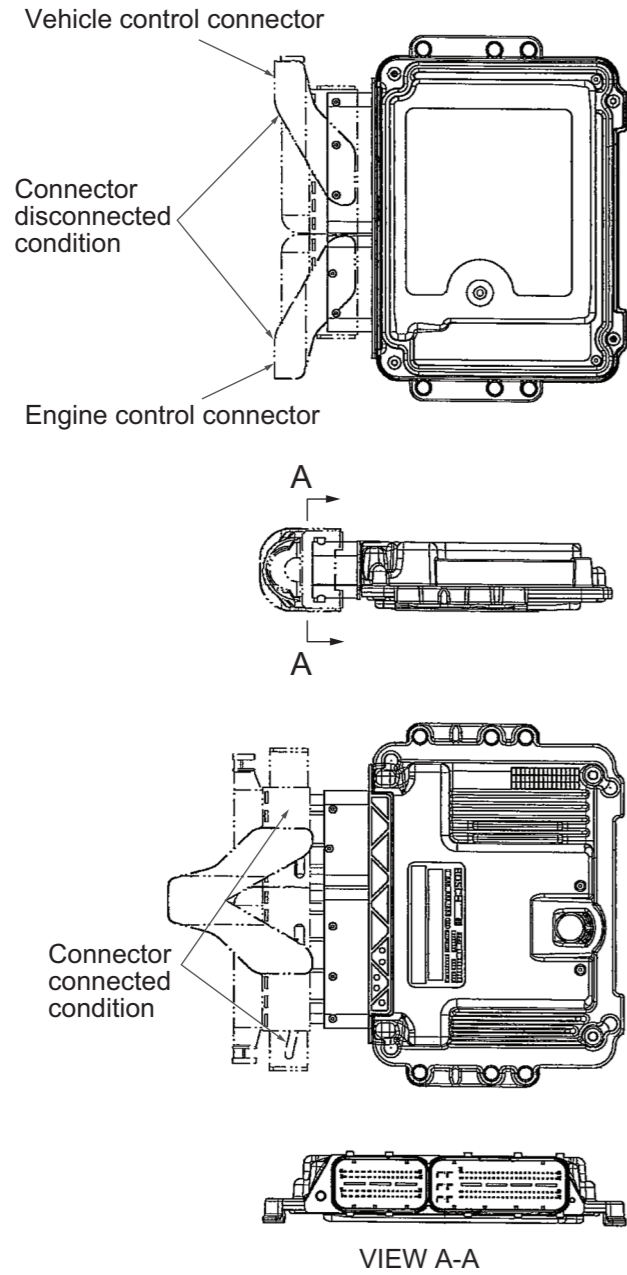

- Hinweise: (N...)**
1. Gerätebezeichnung nach H 829908 Teil 1, z.B. (B46)
 2. Verdrihte Leitungen
 3. Pinbelegung Bosch Stecker 94-Pol (D2.2/K) Buchsengehäuse Kontaktseite
 4. Pinbelegung ITT-Cannon Stecker 12-Pol (X22) Buchsengehäuse Kontaktseite
 5. Leitungsquerschnitte 0,75qmm, sofern nicht anderes angegeben.
 6. Maximale Leitungslänge für die Spannungsversorgung 3,5m in der hier dargestellten Installation.
Maximale Leitungslänge für die Spannungsversorgung 10m bei einer Kabelbaum-Umgebungstemperatur von 85 °C. (4 x 2,5 qmm Leitungen parallel verbunden)
 7. Pinbelegung (ähnlich DIN72585) Stecker 7-Pol (B50) Buchsengehäuse Kontaktseite
- Notes: (N...)**
1. equipment declaration according to H 829908 part 1, e.g. (B46)
 2. twisted wires
 3. pin assignment Bosch connector 94-pol (D2.2/K) female housing contact face
 4. pin assignment ITT-Cannon connector 12-pol (X22) female housing contact face
 5. wire cross-sections 0,75sqmm unless otherwise specified
 6. maximum wire length for Battery wires in mapped application 3,5m.
maximum wire length for Battery wires 10m at 85°C harness ambient temperature (4 x 2,5 sqmm wires connected in parallel)
 7. pin assignment (similar DIN72585) connector 7-pol (B50) female housing contact face

EMR CONNECTOR																			
1	2	3	4	5	6	7	8	9	10	11	12	13	14	15	16	17	18	19	20
94	X	94	X	94	X	*	*	*	*	*	*	*	97	96	*	*	*	*	*
1.25YR	1.25B	1.25YR	1.25B	1.25YR	1.25B								BrR	RW					
21	22	23	24	25	26	27	28	29	30	31	32	33	34	35	36	37	38	39	40
*	*	*	*	104	*	*	52	*	*	*	*	*	*	*	*	*	*	*	*
*	*	*	*	BrY	*	*	BR	*	*	*	*	*	*	*	*	*	*	*	*
41	42	43	44	45	46	47	48	49	50	51	52	53	54	55	56	57	58	59	60
*	*	30	*	*	*	*	*	*	*	*	*	*	*	103	*	*	*	*	108
*	*	BY	*	*	*	*	*	*	*	*	*	*	LR	*	*	*	*	Y	
61	62	63	64	65	66	67	68	69	70	71	72	73	74	75	76	77	78	79	80
106	105	101	102	*	*	*	*	*	*	*	95	*	*	*	*	109	*	111	*
RY	RB	GR	GY	*	*	*	*	*	*	*	BY	*	*	*	P	*	LgB	*	
81	82	83	84	85	86	87	88	89	90	91	92	93	94						
*	107	*	*	*	*	*	*	*	*	*	*	*	*						
*	YB	*	*	*	*	*	*	*	*	*	*	*	*						

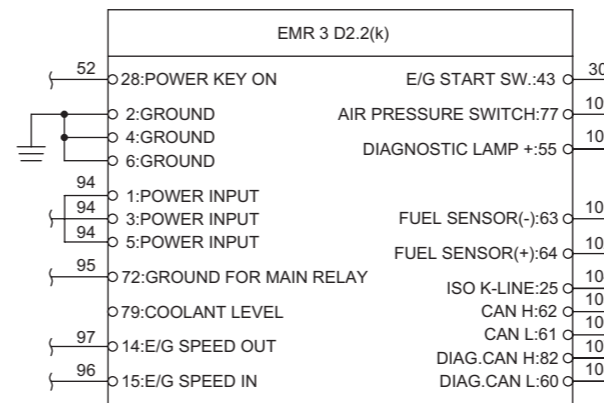
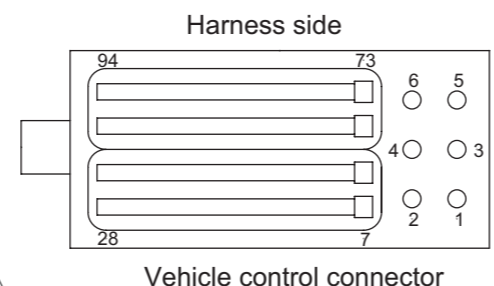

Wire color and number (Refer to "1-4 Wire Color Code and Number" of TROUBLESHOOTING.)

The arrangement of connector terminals shown below is that of connecting surfaces on the connector side.

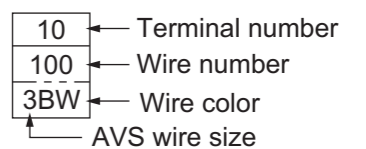

3-4. Resistor

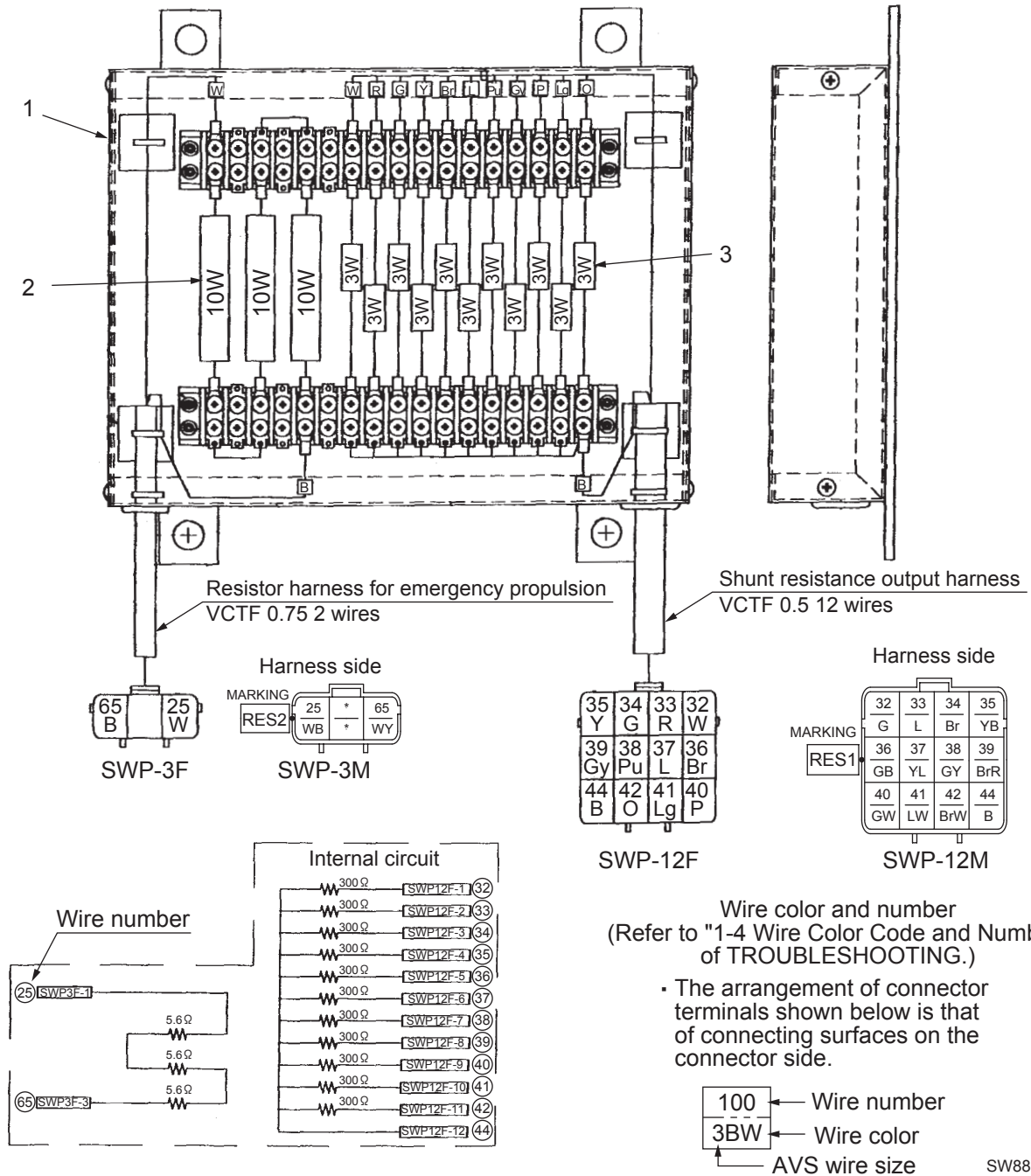

- (1) Case
- (2) Cement resistor: 5.6 Ω 10 W
- (3) Resistor: 300 Ω 3 W

Wire color and number
 (Refer to "1-4 Wire Color Code and Number"
 of TROUBLESHOOTING.)

- The arrangement of connector terminals shown below is that of connecting surfaces on the connector side.

100 ← Wire number
 3BW ← Wire color
 ← AVS wire size

SW880-05008

3-5. Combination Meter

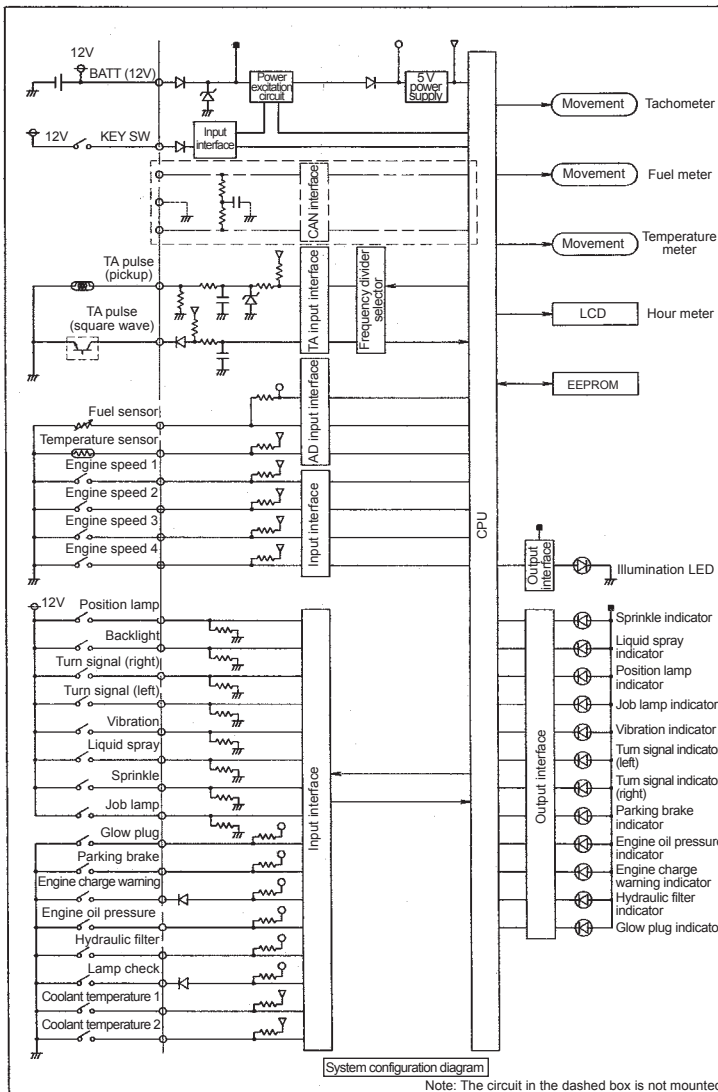
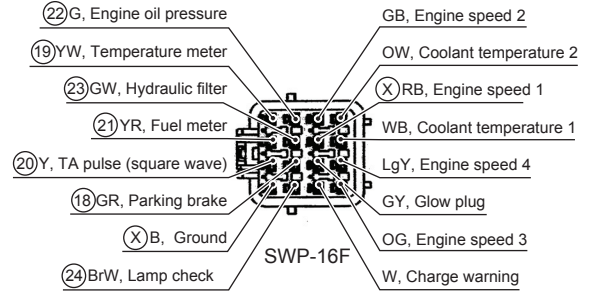
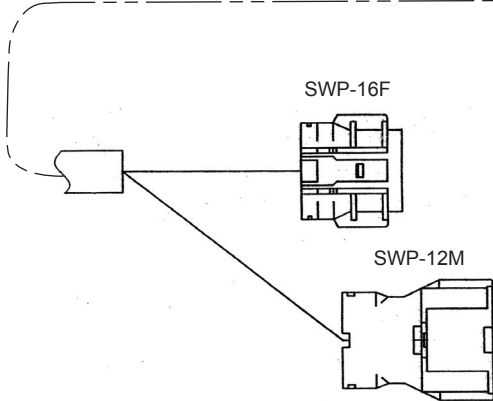
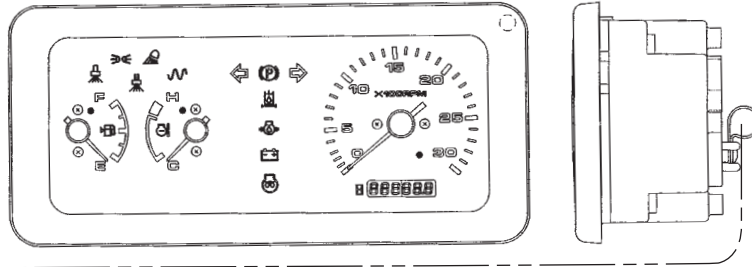

SWP-16M

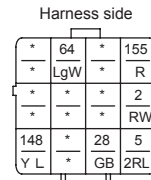
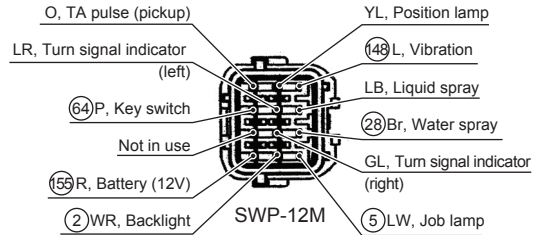

SWP-12F

Wire color and number
(Refer to "1-4 Wire Color Code and Number" of TROUBLESHOOTING.)

- The arrangement of connector terminals shown below is that of connecting surfaces on the connector side.

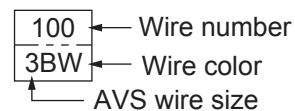

3-6. Exact Meter

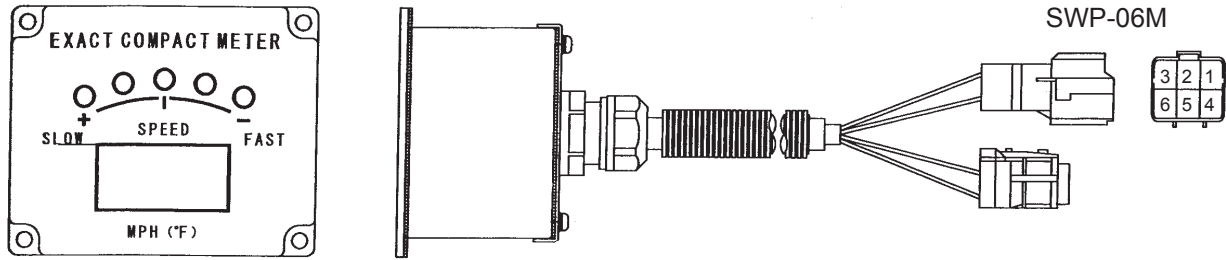

Wire color and number
 (Refer to "1-4 Wire Color Code and Number" of TROUBLESHOOTING.)

- The arrangement of connector terminals shown below is that of connecting surfaces on the connector side.

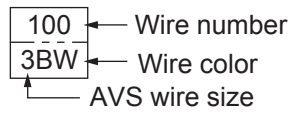

Harness side

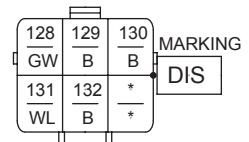

SWP-06F

SW880-05010

3-7. Potentiometer

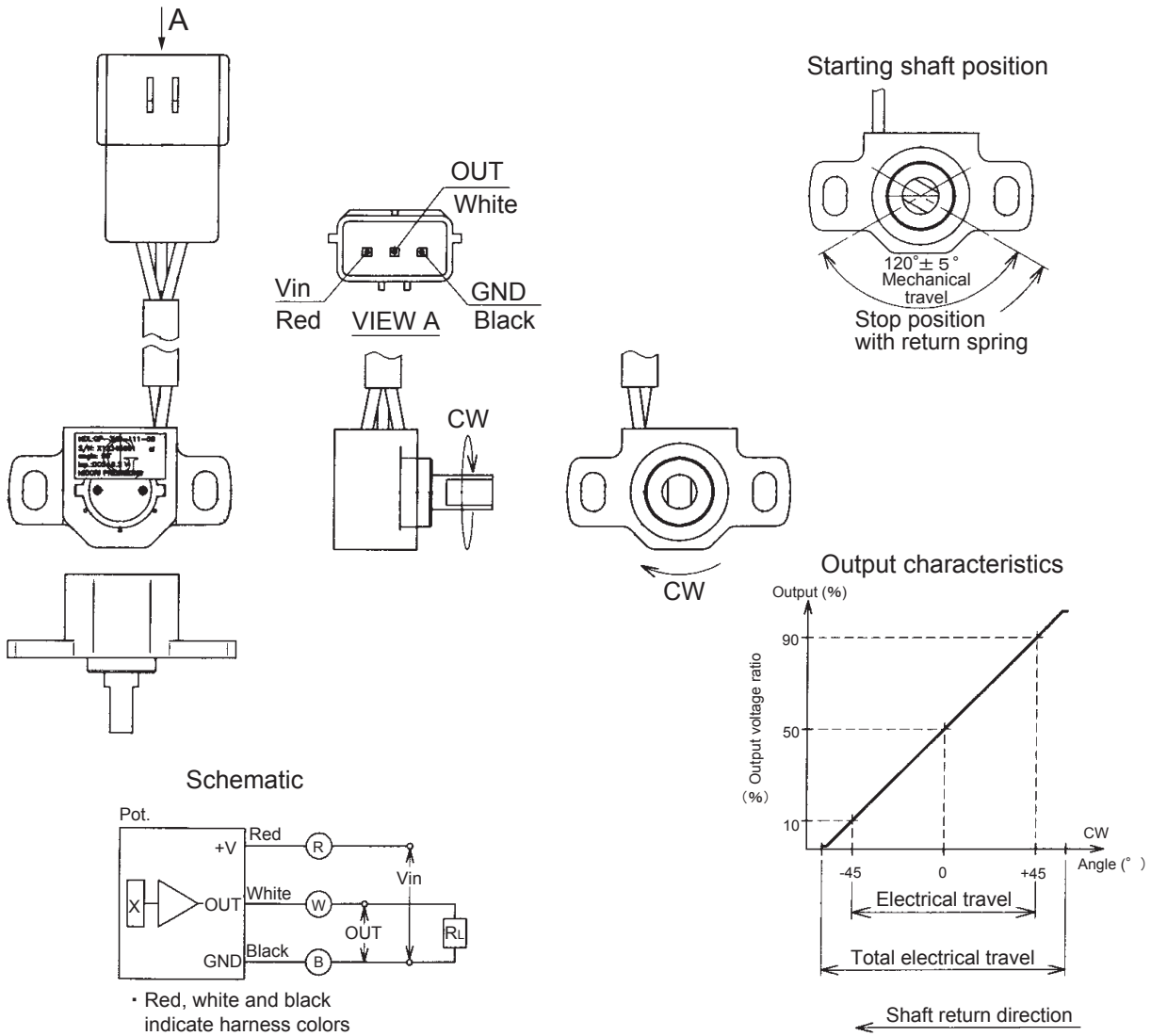

SW880-05011

Specifications

- Model :
- Effective electrical angle : $\pm 45^\circ$
- Output sensitivity : $0.82 - 0.96 \%V_{in}/^\circ$
- Independent linearity : $\pm 2 \%FS (FS=90^\circ)$
- Applied voltage : $DC5 \pm 0.5 V$
- Insulation resistance : $100M\Omega MIN. DC50V(at normal temperature and humidity)$
- Machine angle : $120 \pm 5^\circ$
- Consumption current : $10 mA MAX.$
- Load resistance : $10 K\Omega MIN.$
- Rotary torque : $5 - 30 N \cdot m$
- Water resistance : $IP 65$
- Operating/storage temperature range : $-40 - 125C^\circ (no condensation allowed)$
- Weight : $50 g (0.1 lb)$

3-8. Lever Switch

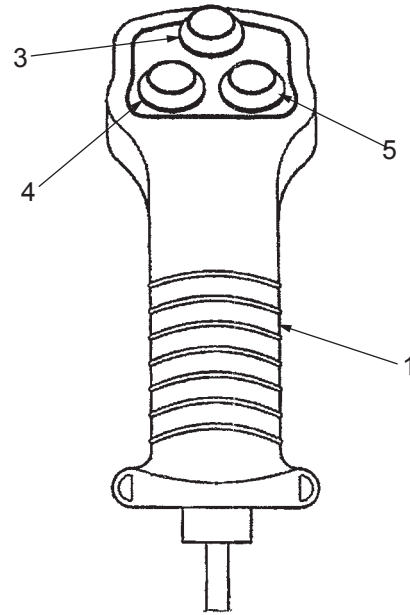
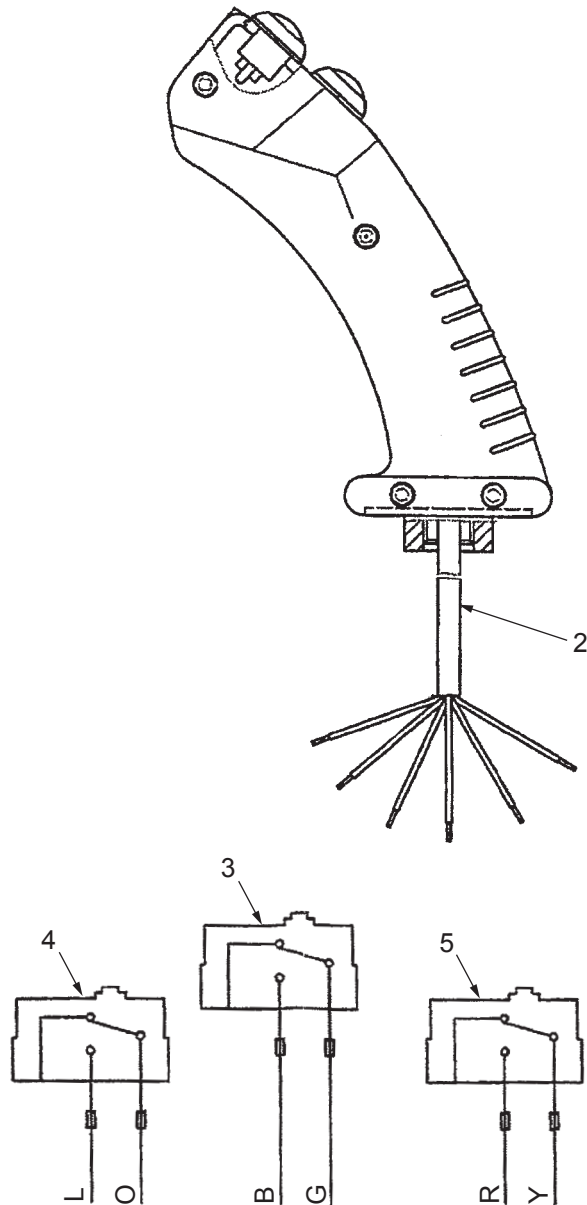

Harness side

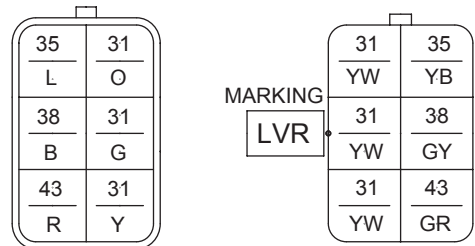

Wire color and number
(Refer to "1-4 Wire Color Code and Number" of TROUBLESHOOTING.)

- The arrangement of connector terminals shown below is that of connecting surfaces on the connector side.

Electrical circuit

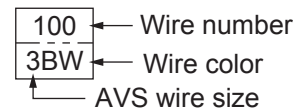

SW880-05012

- (1) Handle shell
- (2) Switch cord assembly
- (3) Automatic speed setting switch (White)
- (4) Vibrator switch (Green)
- (5) Water spray switch (Blue)

VIBRATORY DRUM

1. PRECAUTIONS FOR DISASSEMBLY AND REASSEMBLY

- When removing, installing, disassembling or reassembling the unit, observe the general precautions described below.

1) Precautions for removal work

- Coolant that contains antifreeze should be treated as a chemical, and must not be drained carelessly on the ground.
- To prevent dust from getting into disconnected hoses and tubes, cover them with a plug or similar means.
- When draining oil, use a receptacle with sufficient capacity to receive it.
- Before proceeding with the work, look for matchmarks that show the installation location. For reassembly, place matchmarks in the required locations to prevent errors. Then remove.
- When disconnecting wiring connectors, hold the connector components so that unreasonable force is not applied to the wires.
- Label wires and hoses to ensure correct installation location.
- Confirm the number and thickness of shims prior to storage.
- When lifting parts, use lifting equipment of sufficient capacity.
- When separating parts by using pull bolts, tighten the bolts alternately.
- Before removing a unit, clean its surrounding area. Then after removal, cover it to prevent dust and other substances from getting in.
- Before removing piping for hydraulic oil or coolant, or removing related parts, satisfactorily release internal pressure.

2) Precautions for installation work

- Tighten bolts and nuts (sleeve nuts) to the specified torque (screw tightening torque table).
- When installing hoses, do not twist them or allow them to interfere with other parts.
- Replace gaskets, O-rings, split cotter pins, and lock plates with new parts.
- Properly bend split cotter pins and lock plates.
- When applying an adhesive, first clean and remove oil/grease from the surfaces properly. Then apply two or three drops to the threaded areas.
- When applying a liquid gasket, first clean and remove oil/grease from the application surface properly, and confirm that the surface is free of dust and damage. Then apply the product evenly.
- Clean parts well. Repair scratches, dents, burrs, rust, etc.
- Apply gear oil to rotating and sliding components.
- Apply grease to the surfaces of press-fit parts.
- After installing snap rings, confirm that they are properly seated in the grooves.
- Connect wiring connectors securely after cleaning off adhering oil, dust and water.
- Use lifting bolts that are not fatigued or deformed. Screw them in fully.
- When tightening a split flange, tighten screws alternately to prevent uneven tightening.
- Before installing hydraulic parts, confirm that they are free of damage and dust, etc.

3) Precautions when work is completed

- If coolant has been drained, securely retighten the drain cock and fill with coolant (mixing in long-life coolant) to the specified level. Start the engine and allow the coolant to circulate through the piping. Then add coolant again to the specified level.
- If hydraulic equipment has been removed and reinstalled, fill with hydraulic oil to the specified level. Start the engine and allow the oil to circulate through the piping. Then add oil again to the specified level.

2. VIBRATORY DRUM

2-1. Removal and Installation of Vibratory Drum

2-1-1. Removal of vibratory drum

Drain water from the front and rear water tanks before working on the vehicle.

- 1) Couple the front frame and rear frame using the steering lock bar (1) to secure them together.

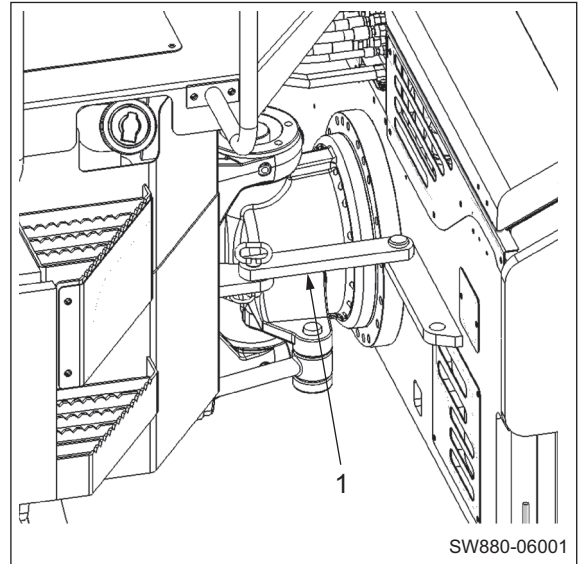



⚠ WARNING

When lifting the vehicle body, use an appropriate hoist of sufficient strength. Confirm that the surrounding area is safe, and work in a natural, unstrained posture.

Also, to firmly secure the vehicle body, use a support stand of sufficient strength.

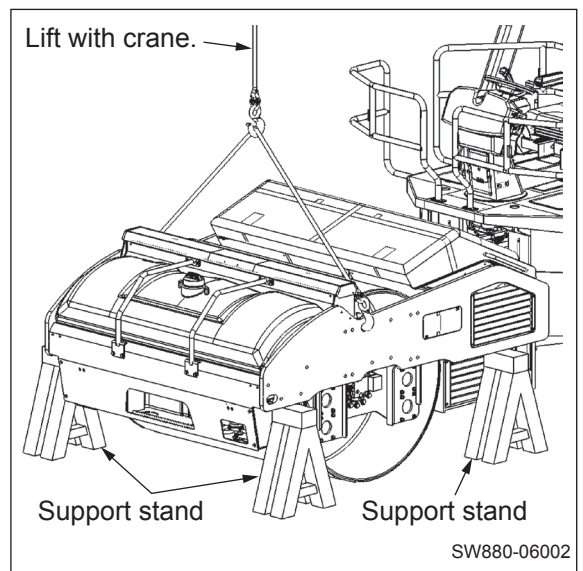
- 2) Lift the frames with a crane.
 - With the drum lifted a little off the ground, place support stands under both sides of each frame to hold the vehicle body in place. (The front and rear frames are structurally identical.)



 Weight of front frame
 SW880 : 6,610 kg (14,570 lbs.)
 SW990 : 6,910 kg (15,235 lbs.)

 Weight of rear frame
 SW880 : 6,800 kg (14,990 lbs.)
 SW990 : 6,910 kg (15,235 lbs.)

- 3) Remove the guard pipes (2).

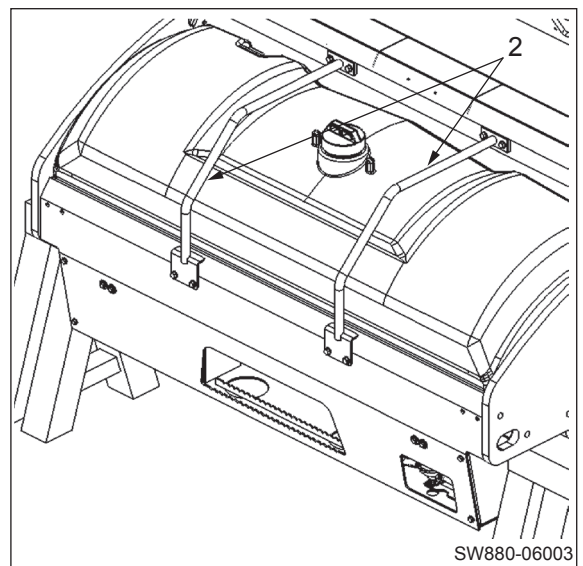

VIBRATORY DRUM

- 4) Loosen the hose clamps (3) and remove the water spray hoses (4).

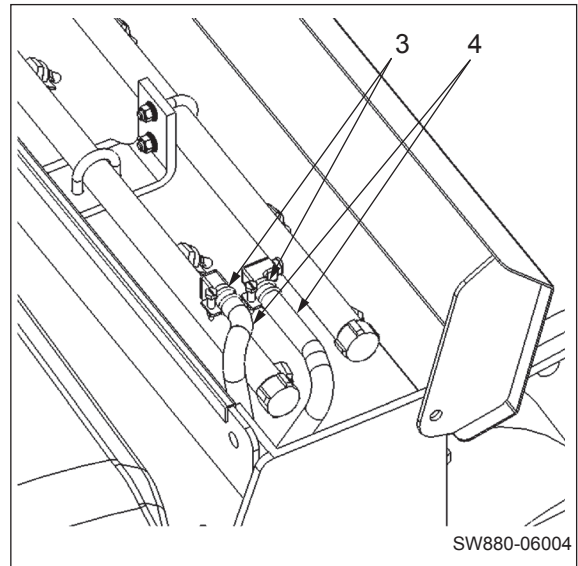

- 5) Remove the hose clamp (5).
- Remove the two bolts (6) (left and right).
 - Pull out the tank stoppers (7) (left and right).

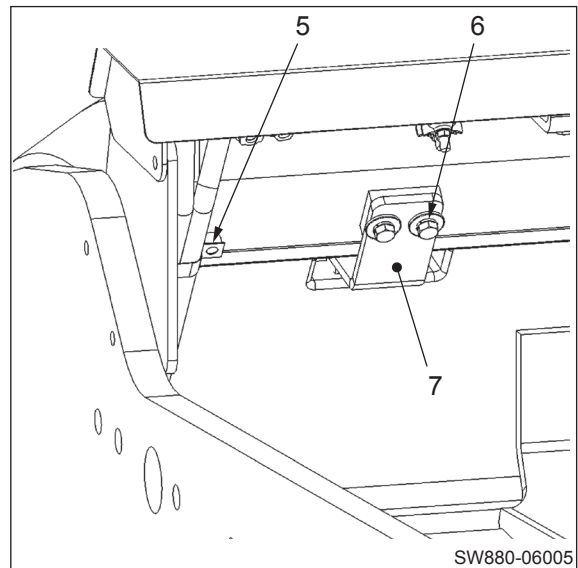

- 6) Lift the member (8) and water spray pipe cover (9) with a crane and hold them.
- Remove the two bolts (10) (left and right).
 - Lift the member (8), water spray pipe cover (9) and the brackets (11) (left and right) and remove them.

 Weight of parts to be lifted : 75 kg (165 lbs.)

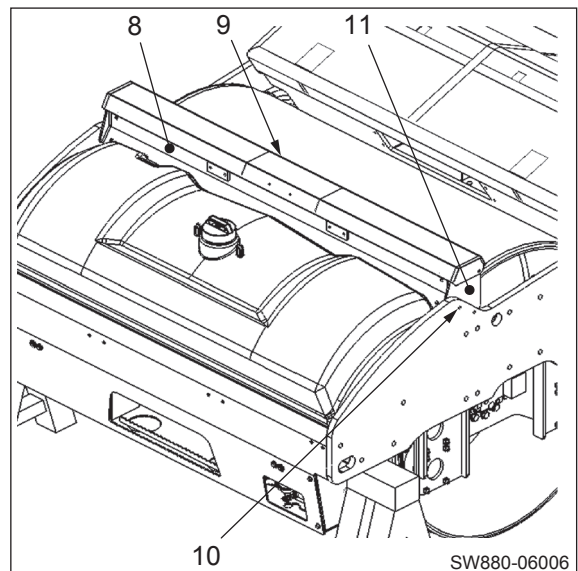

- 7) Loosen the hose clamp (12) at the outlet of the water tank.
- Disconnect the water spray hose (13).

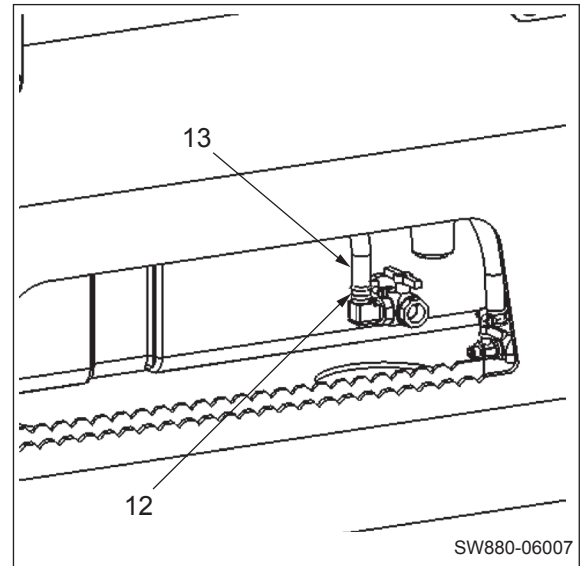

- 8) Remove the bolt (14) fixing the drain cap chain.
- Remove the four cover fixing bolts (15) (left and right).
 - Remove the covers (16) (left and right).

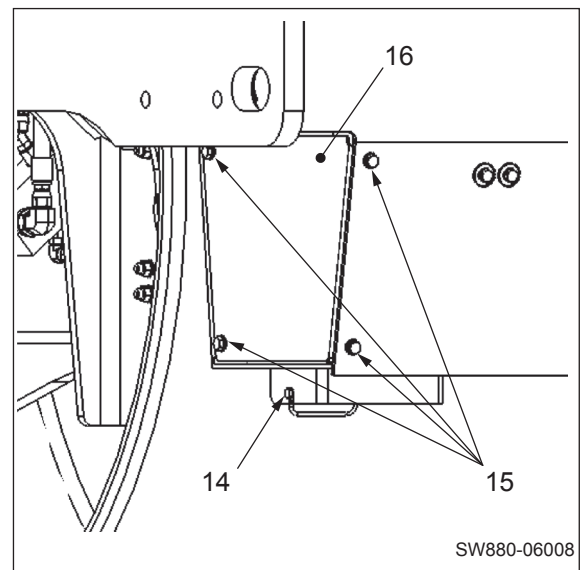

- 9) Remove the two bolts (17) (left and right).
- Pull out the tank stoppers (18) (left and right).

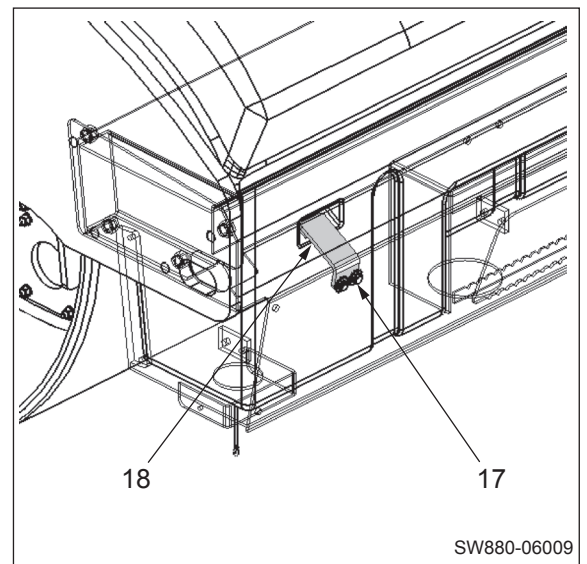

VIBRATORY DRUM

10) Lift the water tank (19) with a crane and remove it from the frame.

(NOTICE)

- Lift the water tank at the water supply port so as not to damage the tank.



Weight of water tank : 50 kg (110 lbs.)

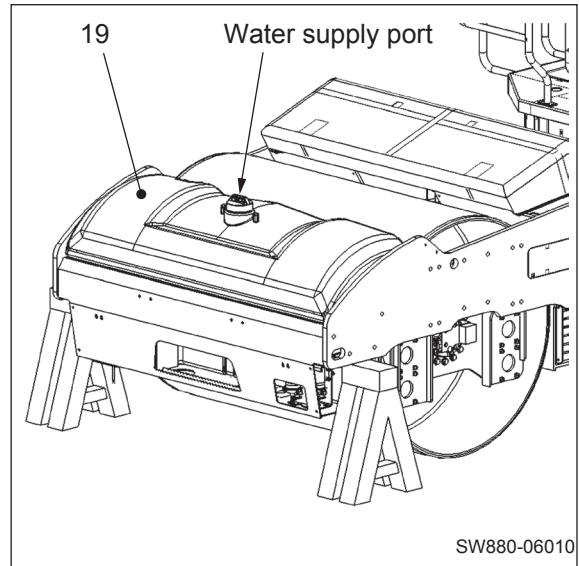

11) Lift the cross member (20) with a crane and hold it.

- Remove the four bolts (21) (left and right).
- Lift the cross member (20) and remove it from the frame.



Cross member

SW880 : 185 kg (408 lbs.)

SW990 : 240 kg (529 lbs.)

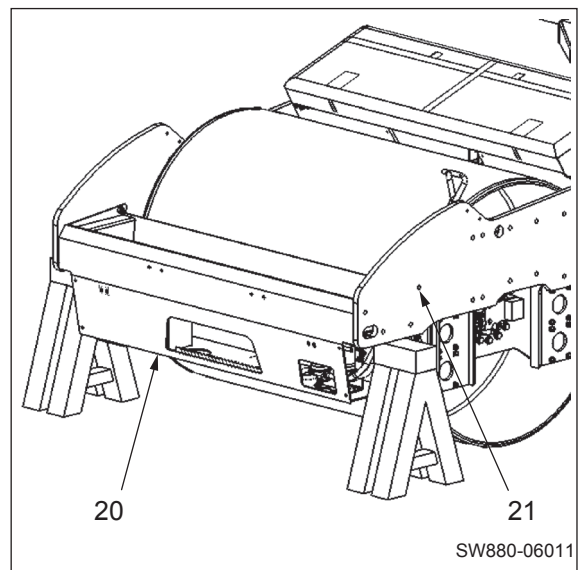

⚠ WARNING

The hydraulic oil in the vehicle is hot and compressed immediately after the vehicle is stopped. Disconnecting the hydraulic hoses in this condition can cause burns. Wait for the hydraulic oil to cool down before starting the work.

12) Disconnection of piping

① Propulsion motor piping

- Remove the hydraulic hose clamp (26).
- Disconnect the four hydraulic hoses (22), (23), (24) and (25) connecting to the propulsion motor.

(NOTICE)

- Plug both ends of the disconnected hoses or implement other actions to prevent entry of foreign matter.

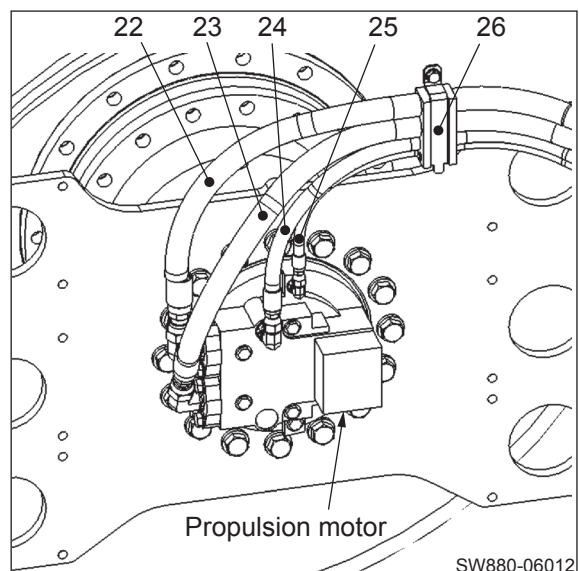

② Vibrator motor piping

- Remove the hydraulic hose clamp (31).
- Disconnect the four hydraulic hoses (27), (28), (29) and (30) connecting to the vibrator motor.

(NOTICE)

- **Plug both ends of the disconnected hoses or implement other actions to prevent entry of foreign matter.**

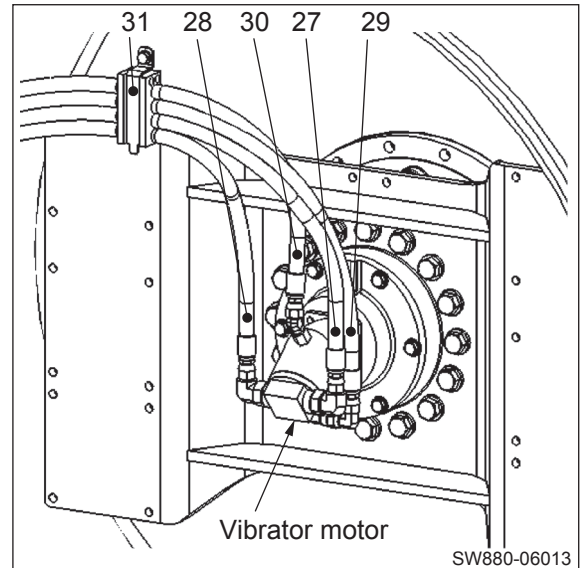

- 13) Lift the drum (32) with a crane and remove the twelve bolts (33) (left and right) taking care not to apply load to the bolts.
- Lift the drum (32) and remove it from the frame.



Weight of drum

SW880 : 3,100 kg (6,834 lbs.)

SW990 : 3,215 kg (7,088 lbs.)

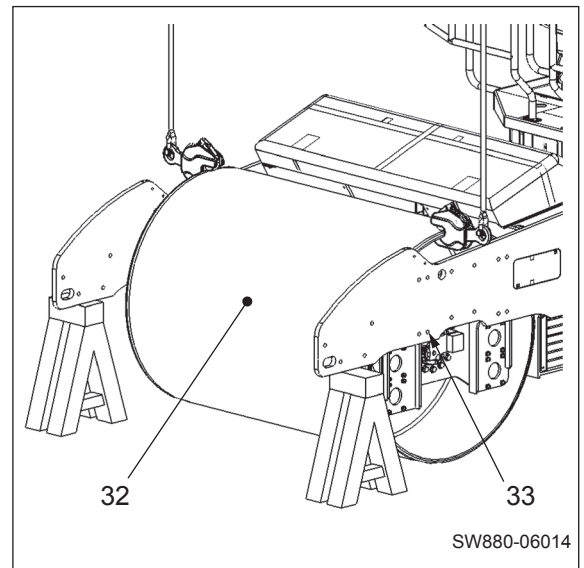

- 14) Place support stands or the like under the vehicle body from which the drum have been removed as shown on the right.

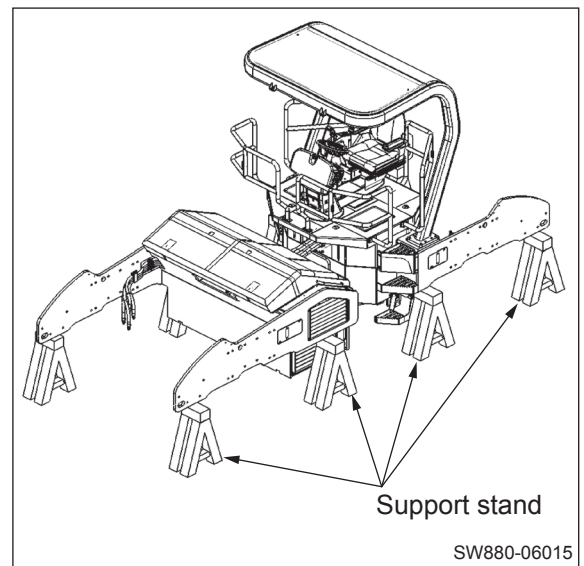

VIBRATORY DRUM

- 15) Put chocks or the like under the removed drum (32) to prevent it from moving.

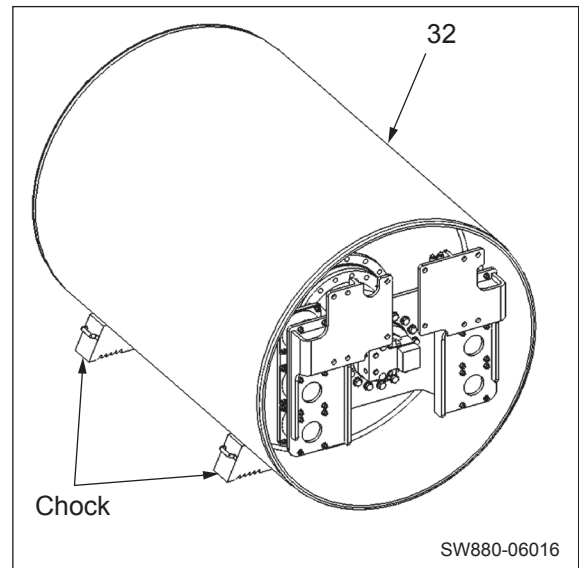

2-1-2. Installation of vibratory drum

- 1) Install the vibratory drum in the reverse order in which it was removed.
 - Tightening torques for the bolts where particular care is required when installing the vibratory drum



(21) M20×70 : 539 N·m (398 lbf·ft)

Cross member

(33) M22×90 : 685 N·m (506 lbf·ft)

Vibratory drum

- 2) Upon installing the vibratory drum, pay particular attention to the following precaution.

⚠ WARNING

If the engine is run at high speed or the cylinder is operated to full stroke when the engine is started for the first time after the work is completed, the piston packing or other items may be damaged by air entering into the cylinder.

(NOTICE)

- Fill the hydraulic oil tank to the specified level to make up for any oil leakage.
- Start the engine and circulate the oil through the piping. Then check the oil level again, ensuring that the oil is at the specified level.

2-2. Vibratory Drum Assembly

2-2-1. Vibratory drum assembly

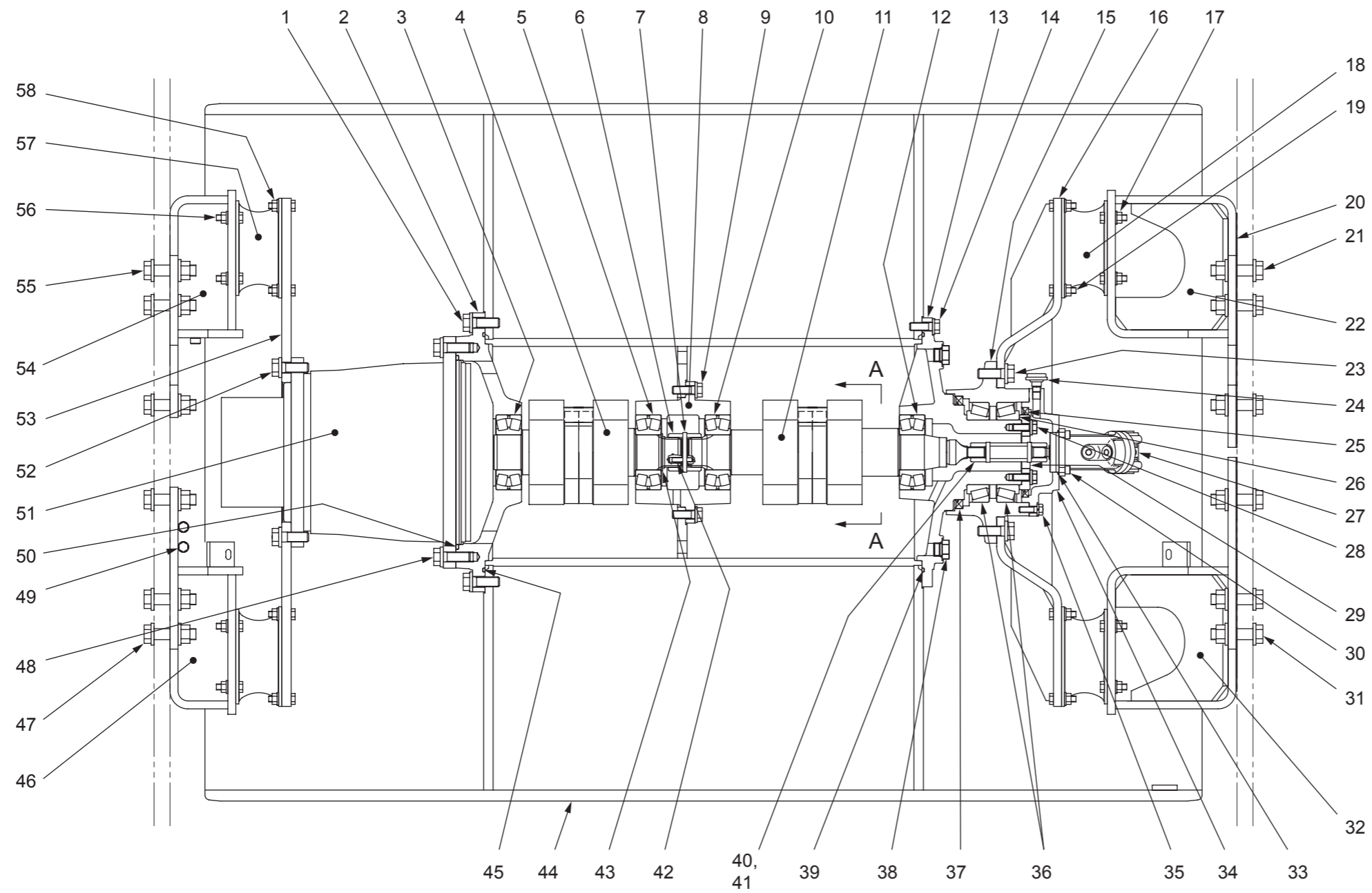

- | | |
|-----------------------|-----------------------|
| (1) Bolt (M20×60) | (30) Bolt (M10×30) |
| (2) Housing | (31) Bolt (M22×90) |
| (3) Vibrator bearing | (32) Bracket |
| (4) Eccentric shaft | (33) O-ring |
| (5) Vibrator bearing | (34) Cover |
| (6) Sleeve | (35) Bolt (M12×40) |
| (7) Spring pin | (36) Roller bearing |
| (8) Housing | (37) Oil seal |
| (9) Bolt (M16×50) | (38) Plug |
| (10) Vibrator bearing | (39) O-ring |
| (11) Eccentric shaft | (40) Sleeve |
| (12) Vibrator bearing | (41) Spring pin |
| (13) Axle shaft | (42) Spring pin |
| (14) Bolt (M16×50) | (43) Snap ring |
| (15) Housing | (44) Drum |
| (16) Bracket | (45) O-ring |
| (17) Bolt (M12×45) | (46) Bracket |
| (18) Damper | (47) Bolt (M22×90) |
| (19) Bolt (M12×45) | (48) Bolt (M20×60) |
| (20) Shim | (49) Bolt (M10×100) |
| (21) Bolt (M22×90) | (50) O-ring |
| (22) Bracket | (51) Propulsion motor |
| (23) Bolt (M20×60) | (52) Bolt (M20×60) |
| (24) Breather | (53) Plate |
| (25) Oil seal | (54) Bracket |
| (26) Shim | (55) Bolt (M22×90) |
| (27) Vibrator motor | (56) Bolt (M12×45) |
| (28) Bolt (M14×40) | (57) Damper |
| (29) Cover | (58) Bolt (M12×45) |

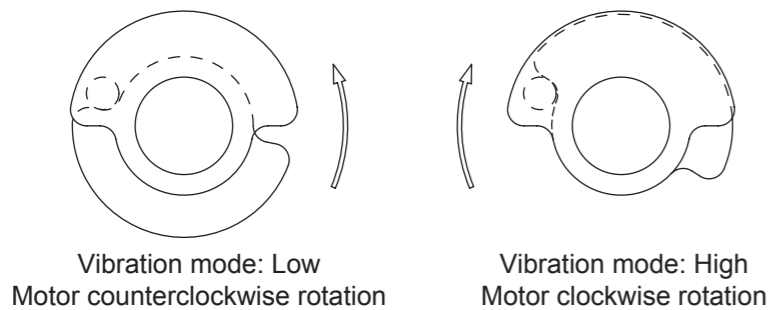

SECTION A-A

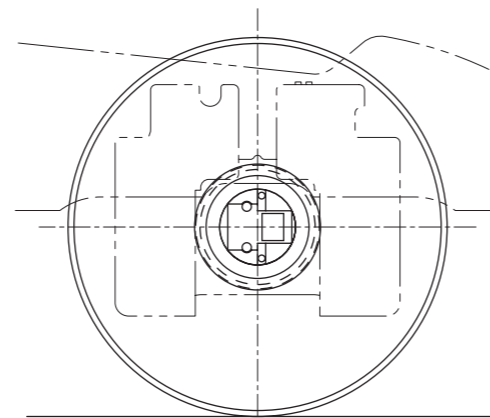

Propulsion motor

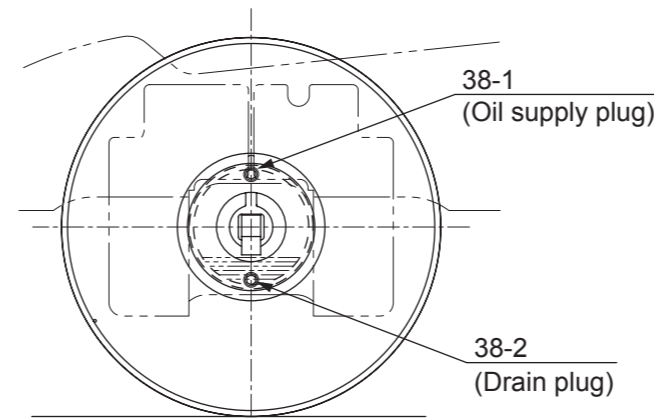

Vibrator motor

0568-43801-0-10152-A

2-2-2. Vibratory drum exploded diagram

- The lead line numbers shown in the illustration are consistent with the part numbers of the vibratory drum shown on page 6-010.

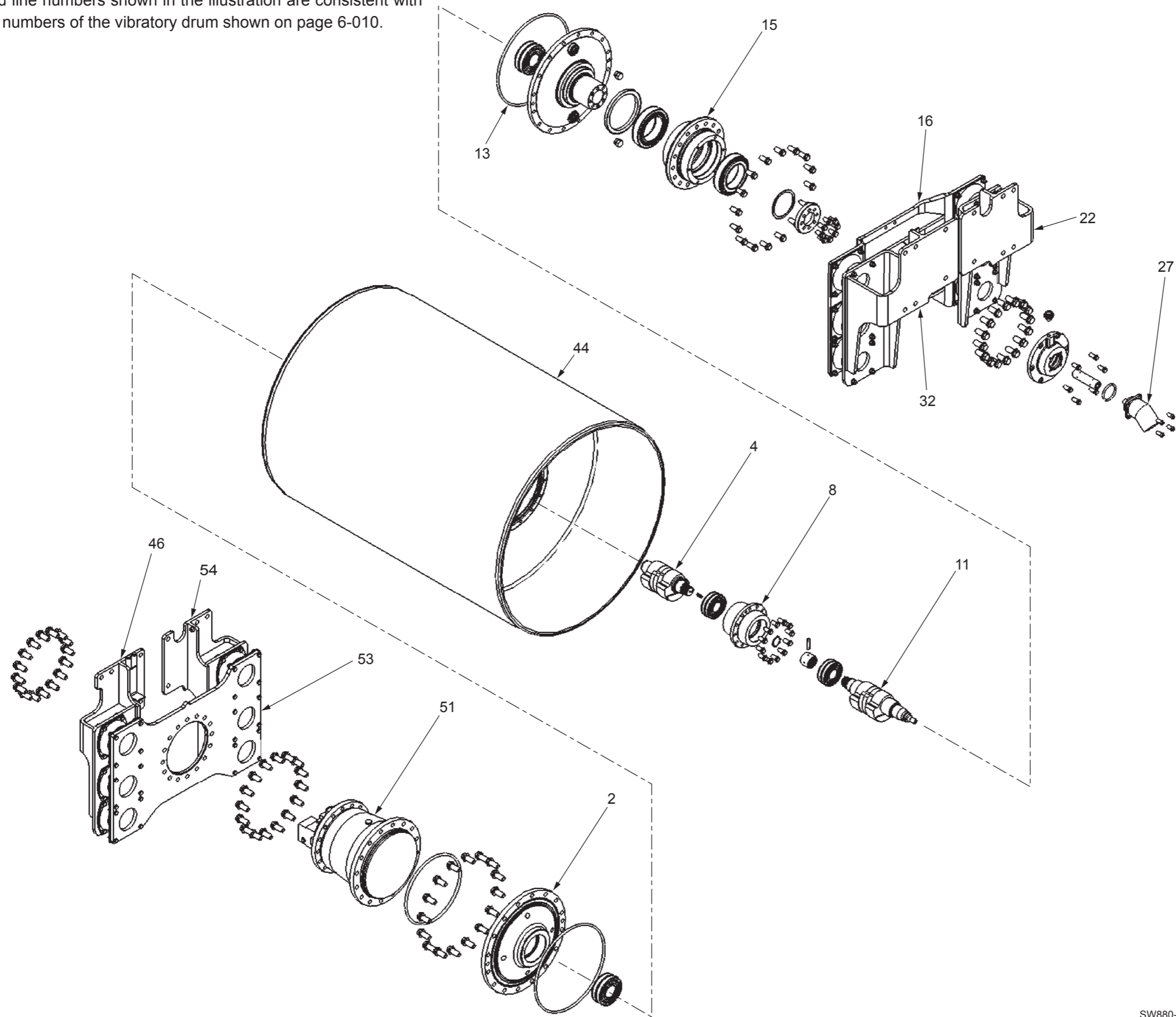

- (2) Housing
- (4) Eccentric shaft
- (8) Housing
- (11) Eccentric shaft
- (13) Axle shaft
- (15) Housing
- (16) Bracket
- (22) Bracket
- (27) Vibrator motor
- (32) Bracket
- (44) Drum
- (46) Bracket
- (51) Propulsion motor
- (53) Plate
- (54) Bracket

2-3. Disassembly and Reassembly of Vibratory Drum

- The lead line numbers shown in the illustrations below are consistent with the part numbers of the vibratory drum shown on page 6-010.

2-3-1. Disassembly of vibratory drum

- 1) Remove the plugs (38-1) and (38-2).
 - Drain the gear oil in the vibrator case.
 - Quantity of gear oil : 22 L (5.8 gal.)

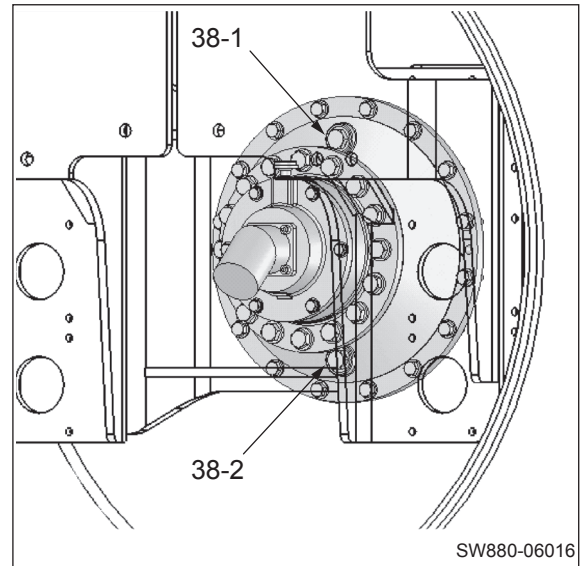

⚠ WARNING

When standing the drum, use wooden blocks of sufficient strength to securely support the drum.

- 2) Lift the vibratory drum with a crane and stand it with its vibrator motor side facing up as shown on the right.

 Vibratory drum assembly
 SW880 : 3,100 kg (6,834 lbs.)
 SW990 : 3,215 kg (7,088 lbs.)

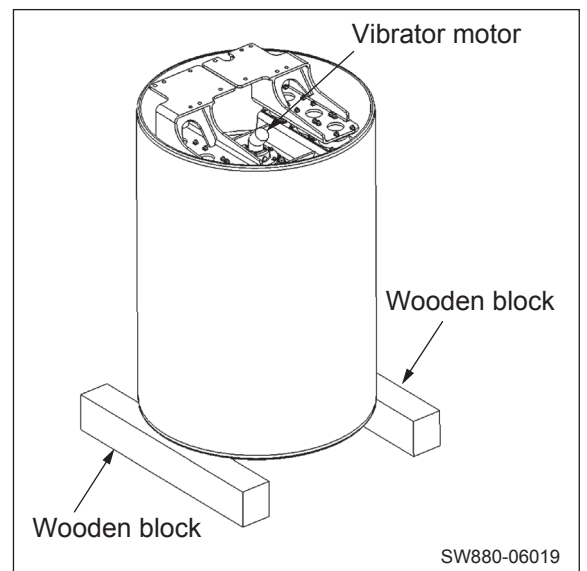

⚠ WARNING

Carry out the work in an unstrained posture using a work stool or the like.

- 3) Remove the four bolts (30).
 - Remove the vibratory motor (27).
 - Remove the breather (24).

 Vibrator motor : 7 kg (15 lbs.)

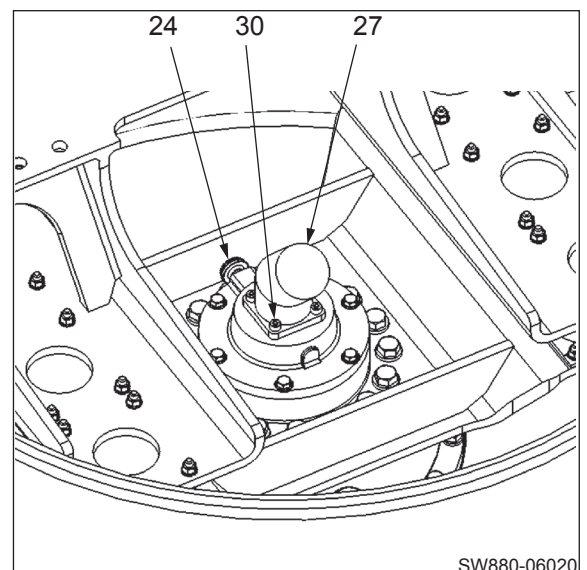

VIBRATORY DRUM

- 4) Install lifting bolts and nuts (M22×2.5) as shown on the right.

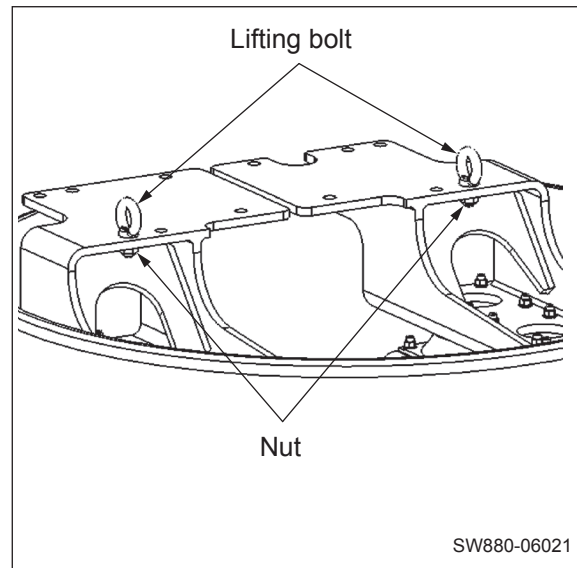

- 5) Remove the sixteen bolts (23).
 - Lift the brackets (22) and (32), damper (18) and bracket (16) together with a crane and remove them.

(NOTICE)

- Since the parts cannot be lifted in a level position in the illustrated state, lift them using a support or the like until the spigot joint of the housing is disengaged.

 Total weight of parts to be lifted (16), (18), (22) and (32) : 290 kg (639 lbs.)

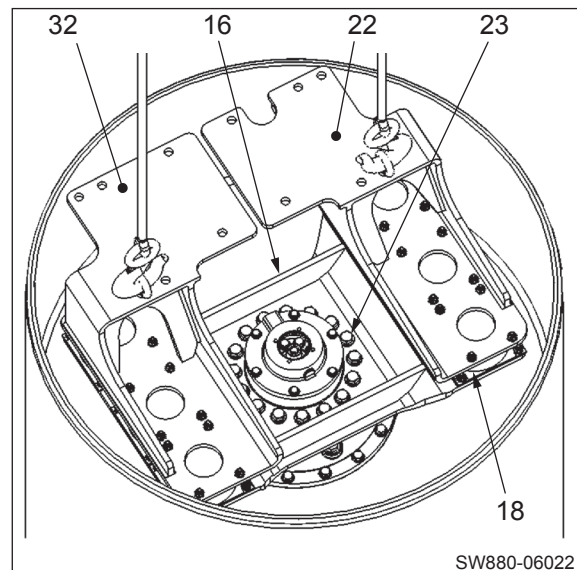

- 6) Pull out the sleeve (40).
 - Remove the sixteen bolts (14).

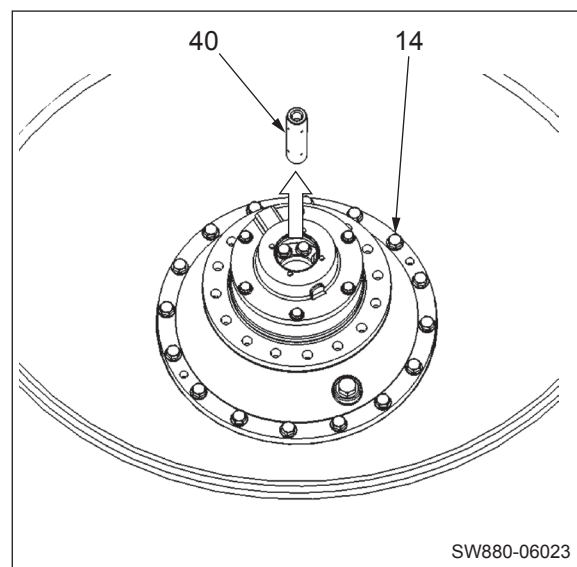

- 7) Using the two pulling bolts (M16×2.0), lift the axle shaft (13).

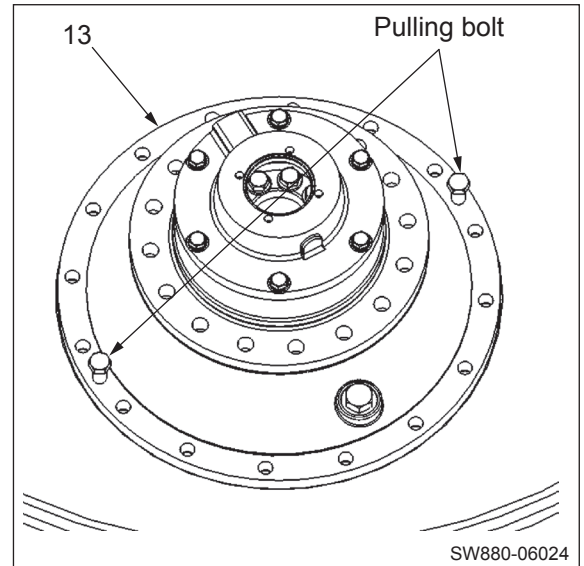

⚠ WARNING

When attaching the lifting bolts, screw in the threads fully before using.

- 8) Install lifting bolts (M16×2.0) on the axle shaft (13).

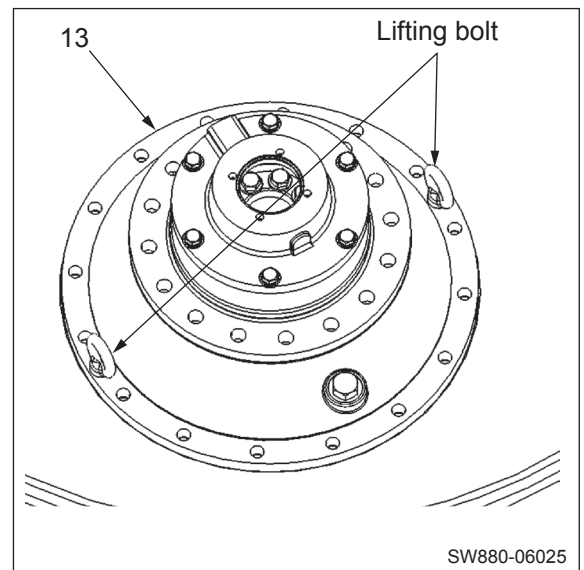

- 9) Slowly lift the axle shaft subassembly with a crane to remove it.

(NOTICE)

- In order not to lift the eccentric shaft together with the axle shaft subassembly, tap on the eccentric shaft end with a wooden hammer via a wooden bar during lifting.

 Axle shaft subassembly : 140 kg (309 lbs.)

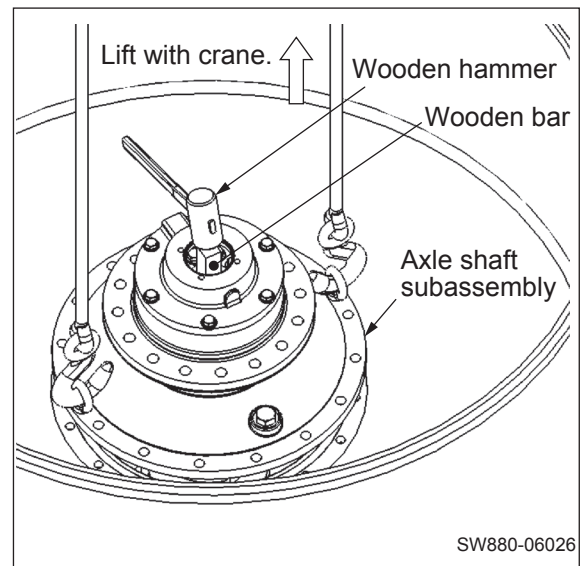

VIBRATORY DRUM

10) Attach a lifting bolt (M8×1.25) to the end of the eccentric shaft (11) and lift the eccentric shaft to remove it.

 Eccentric shaft : 60 kg (132 lbs.)

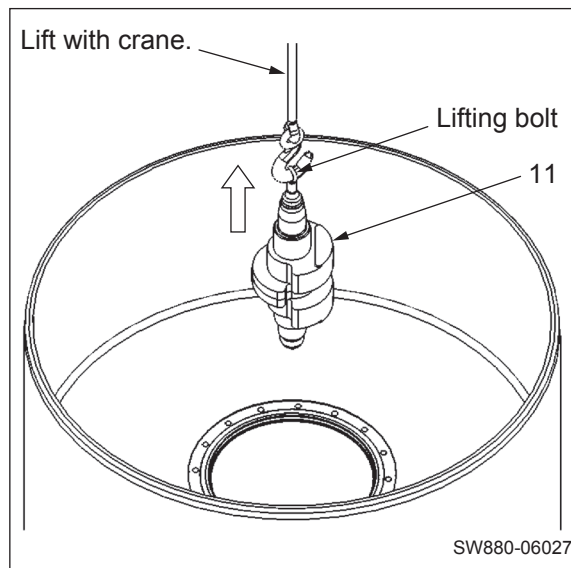

11) Remove the twelve bolts (9).

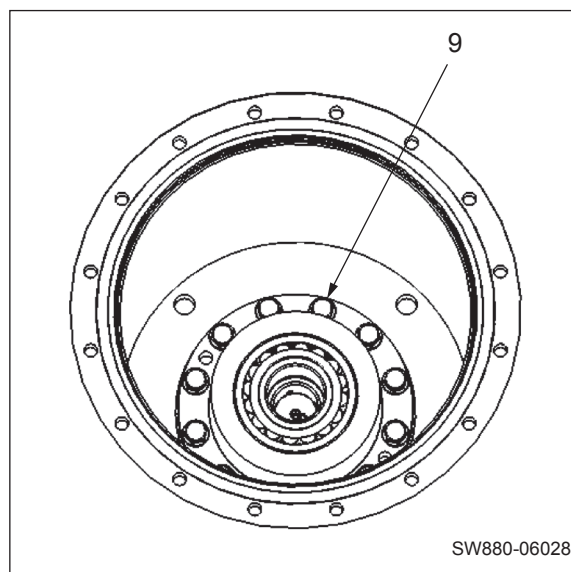

12) Lift the housing (8) using two pulling bolts (M16×2.0).

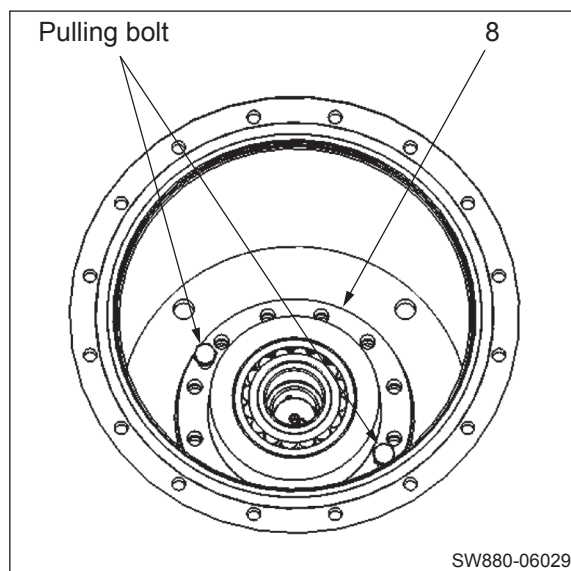

13) Install lifting bolts (M16×2.0) on the housing (8).

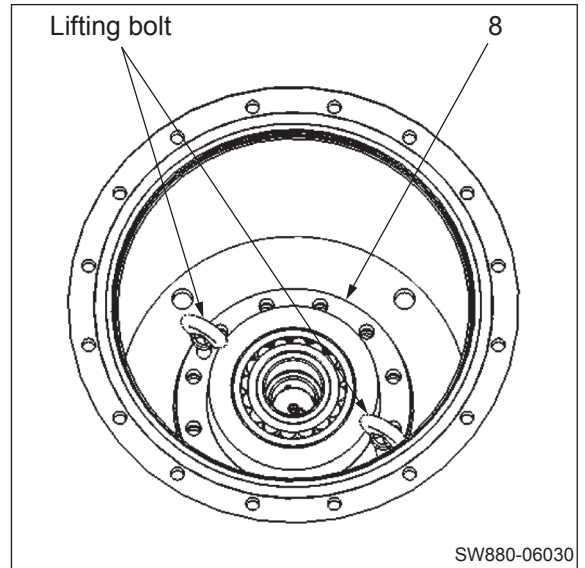

14) Lift the housing subassembly with a crane to remove it.



Total weight of parts to be lifted (8) and (4)
: 100 kg (220 lbs.)

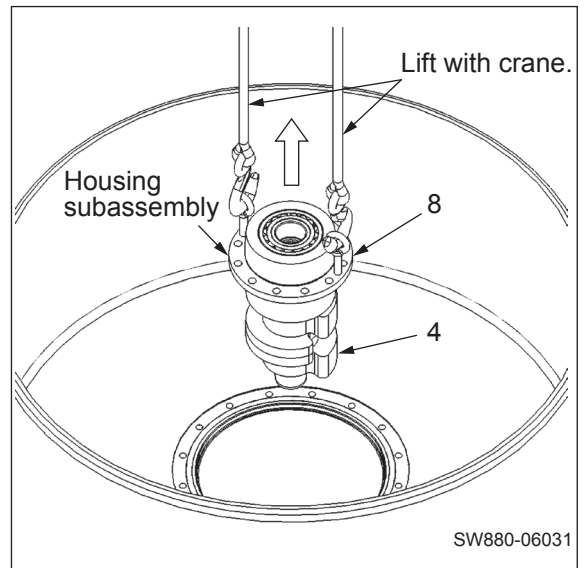

15) Shown on the right is the drum from which the parts have been removed with the vibrator motor side facing up.

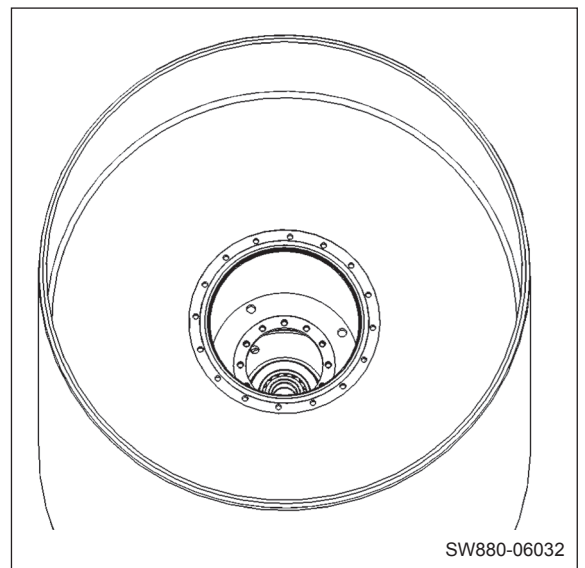

⚠ WARNING

Be careful because reversing the vibratory drum is dangerous work. Confirm that the surrounding area is safe, and work in a natural, unstrained posture.

16) Lift the vibratory drum with a crane and reverse it. Then, stand the drum with its propulsion motor side facing up.



Weight of vibratory drum
in the illustrated condition :

SW880 : 2,570 kg (5,666 lbs.)
SW990 : 2,640 kg (5,820 lbs.)

17) Install lifting bolts and nuts (M22×2.5) as shown on the right.

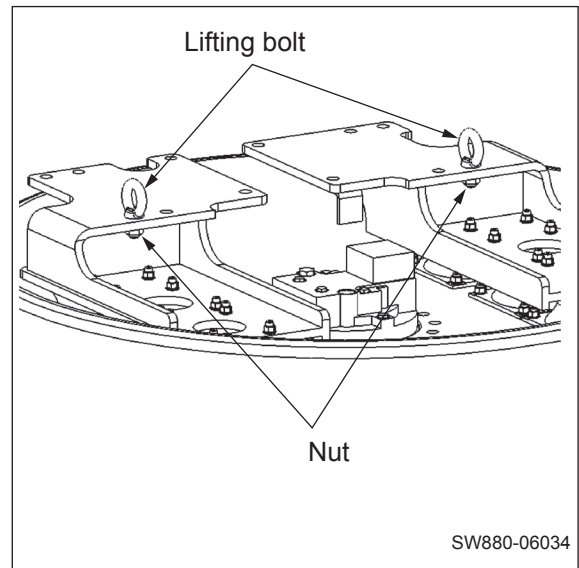
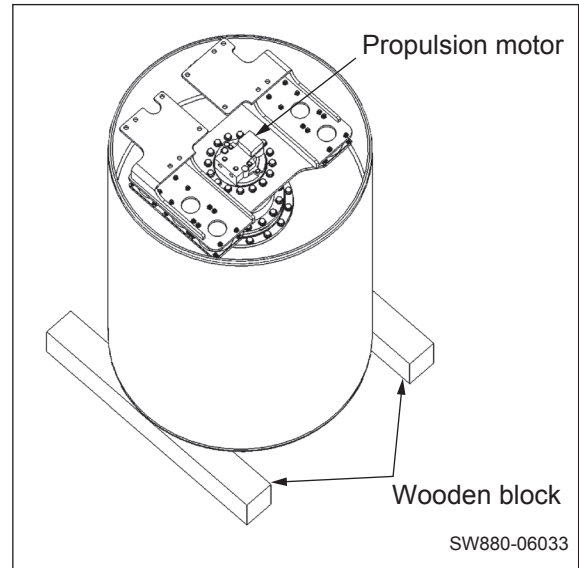

18) Remove the sixteen bolts (52).
• Lift the brackets (46) and (54), damper (57) and plate (53) together with a crane to remove them.

(NOTICE)

• Since the parts cannot be lifted in a level position in the illustrated state, lift them using a support or the like until the spigot joint of the housing is disengaged.



Total weight of parts to be lifted (46), (53), (54) and (57) : 250 kg (551 lbs.)

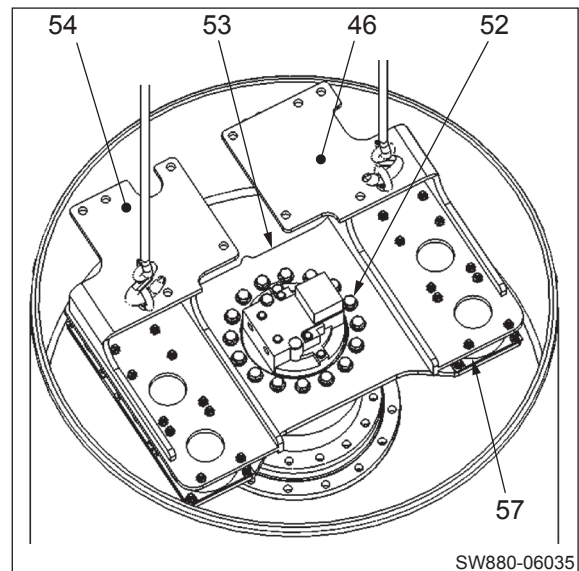

19) Remove the sixteen bolts (48).

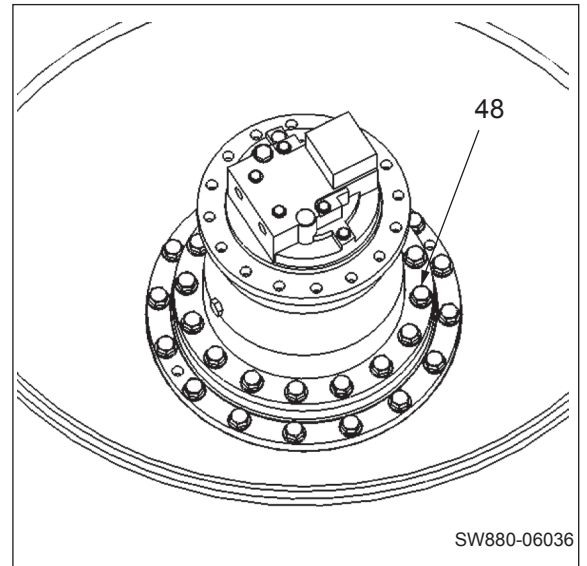

20) Install lifting bolts (M20×2.5) on the propulsion motor (51).

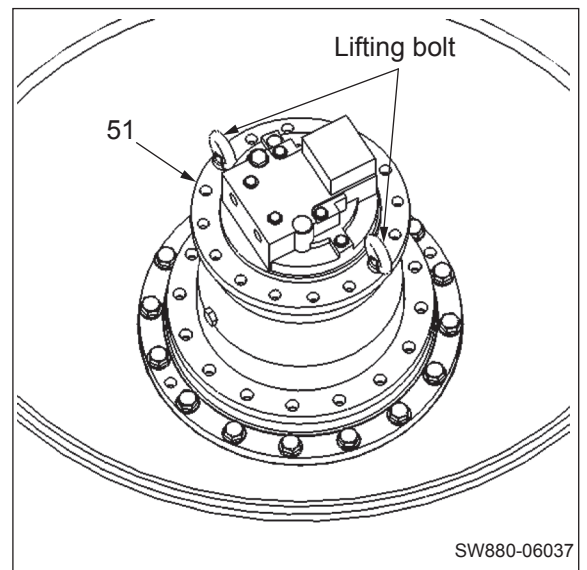

21) Lift the propulsion motor (51) with a crane to remove it.



Propulsion motor : 200 kg (441 lbs.)

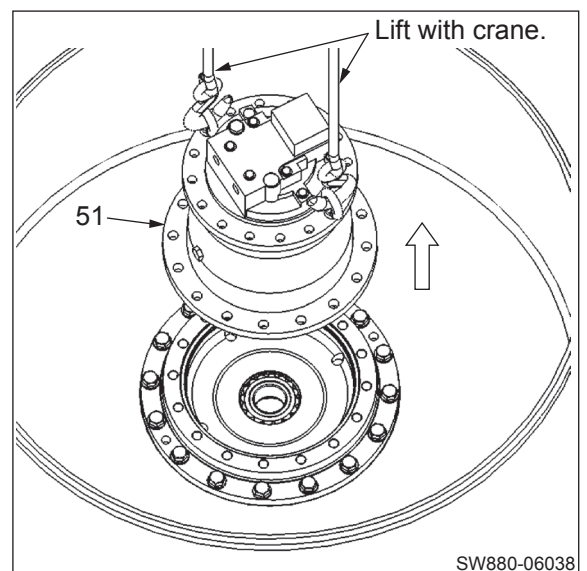

VIBRATORY DRUM

22) Remove the sixteen bolts (1).

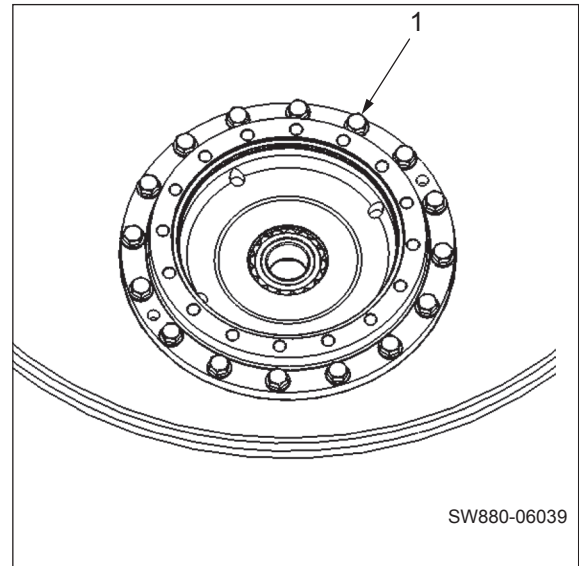

23) Using two pulling bolts (M20×2.5), lift the housing (2).

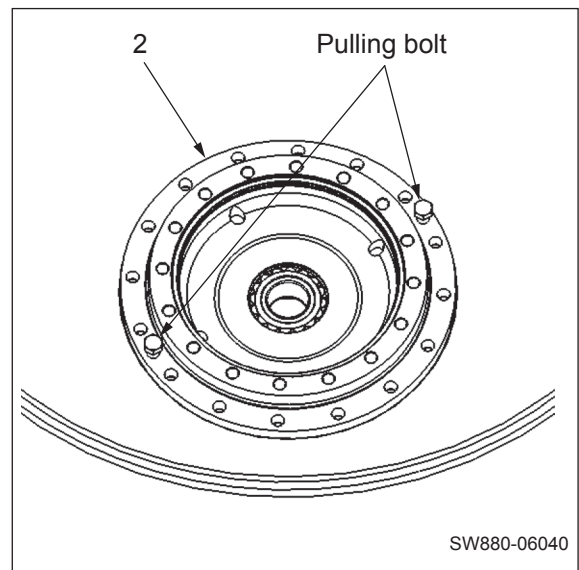

24) Install lifting bolts (M20×2.5) on the housing (2).

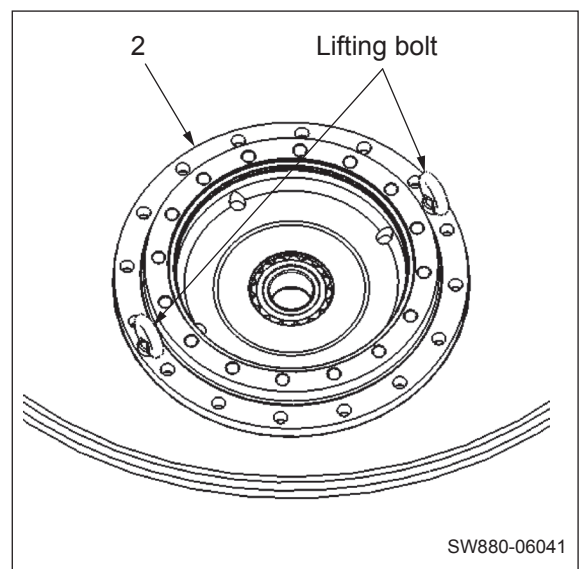

25) Lift the housing (2) with a crane to remove it.

 Housing : 80 kg (176 lbs.)

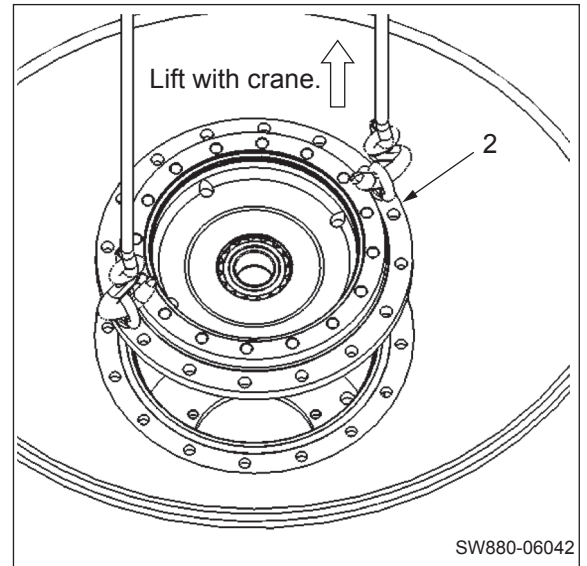

26) Shown on the right is the axle shaft subassembly removed from the vibratory drum.

- Remove the six bolts (35).
- Remove the cover (34).

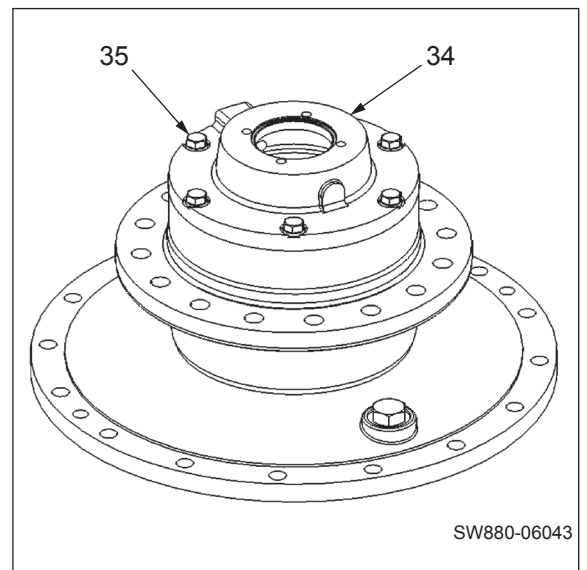

27) Remove the eight bolts (28).

- Remove the cover (29) and shim (26).

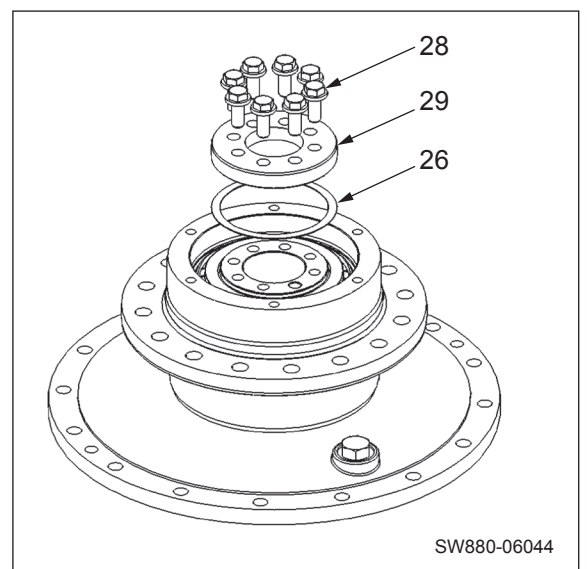

VIBRATORY DRUM

28) Place a protection plate on the end face of the axle shaft (13) and set a puller on the housing (15). Separate the housing (15) together with the roller bearing from the axle shaft (13).

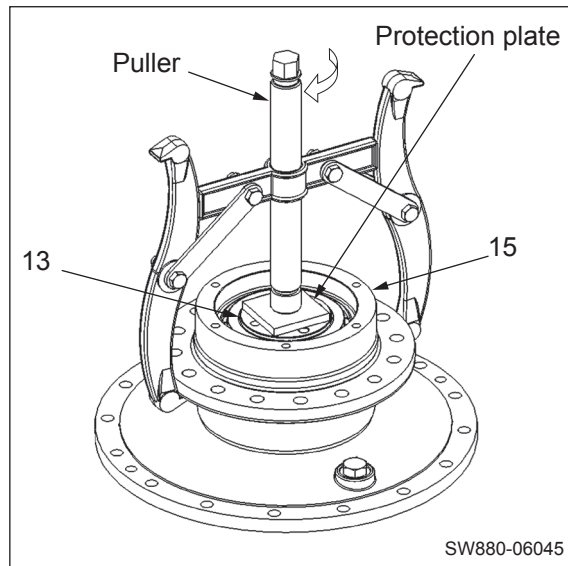

29) Install lifting bolts (M12×1.75) on the housing (15).

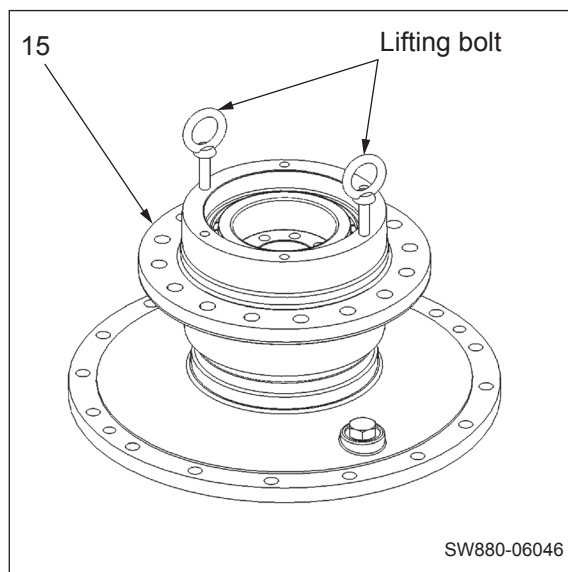

30) Lift the housing (15) with a crane to separate it from the axle shaft (13).



Housing (15) : 50 kg (110 lbs.)

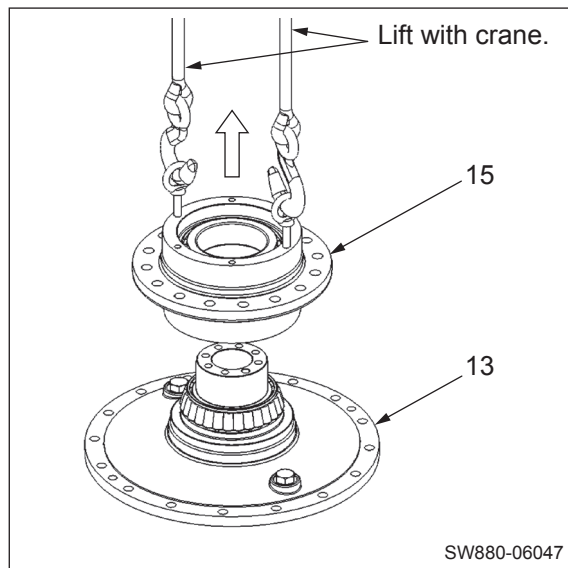

31) Put the housing subassembly on a stand as shown.



Total weight of parts to be lifted (8) and (4)
: 100 kg (220 lbs.)

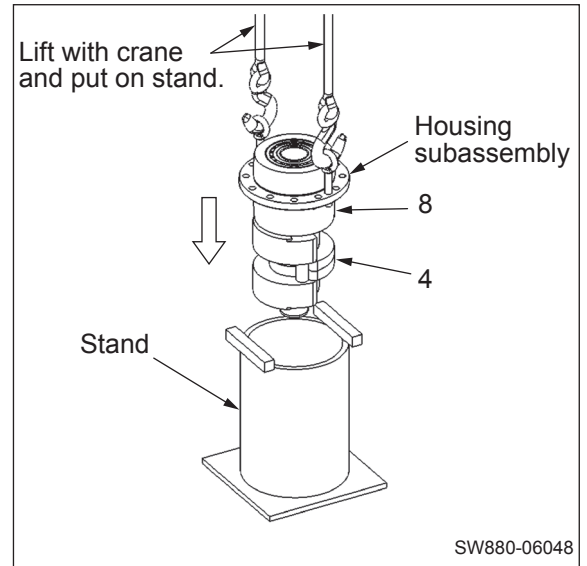

32) Set up a bearing puller on the stand.

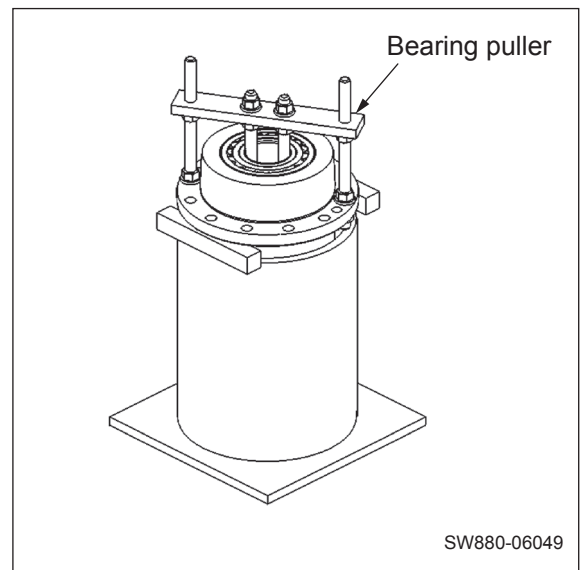
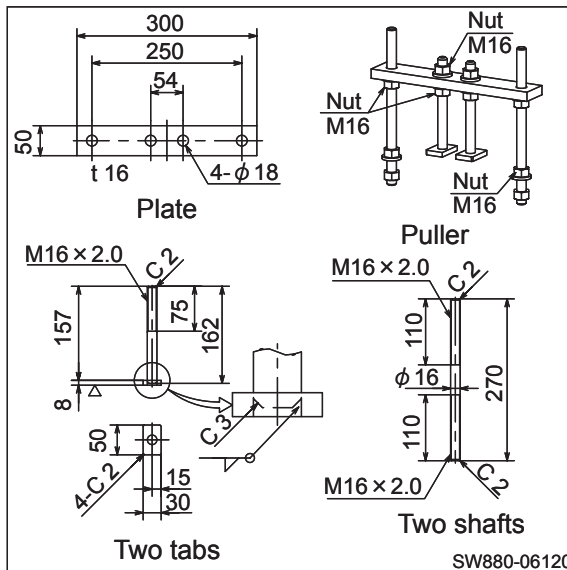

33) Turn the nuts of the bearing puller counterclockwise to remove the vibrator bearing (10).

(NOTICE)

- To prevent the inner race of the vibrator bearing (10) from tilting, alternately turn the nuts on both sides of the puller.

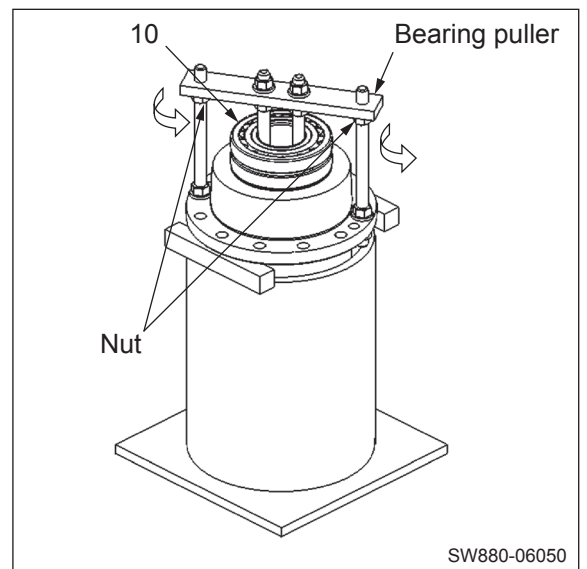

VIBRATORY DRUM

34) Remove the sleeve (6).

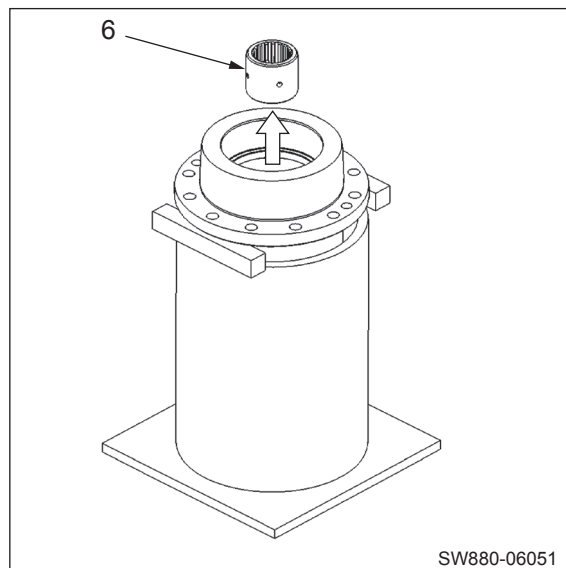

35) Install lifting bolts (M16×2.0) and lift the housing (8) with a crane.



Weight of parts to be lifted : 95 kg (209 lbs.)

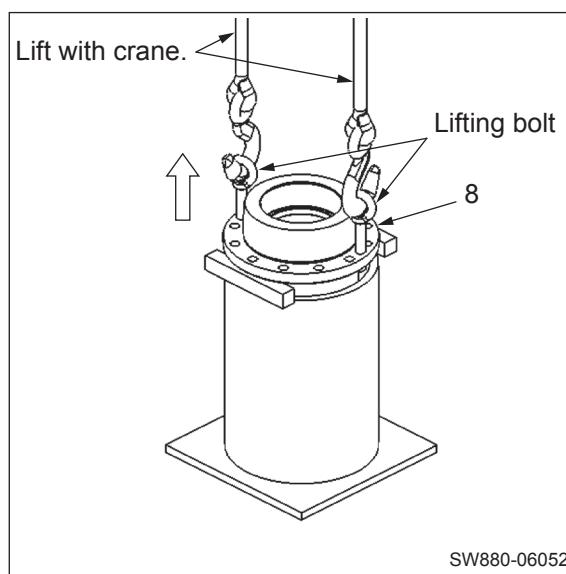

36) Put the housing (8) and eccentric shaft (4) lifted with a crane on wooden blocks.

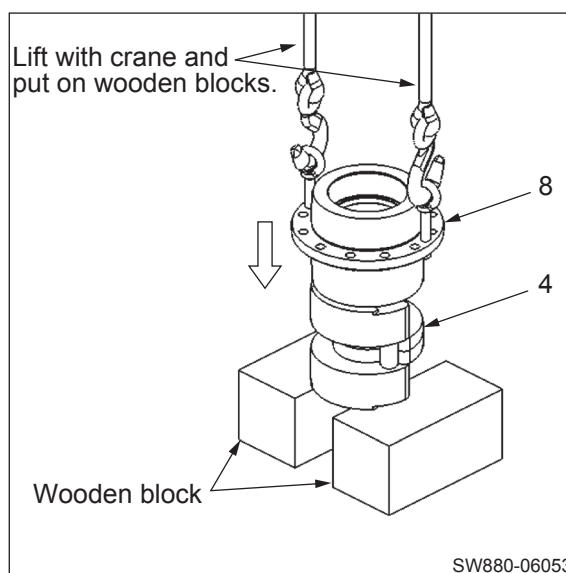

37) Remove the snap ring (43).

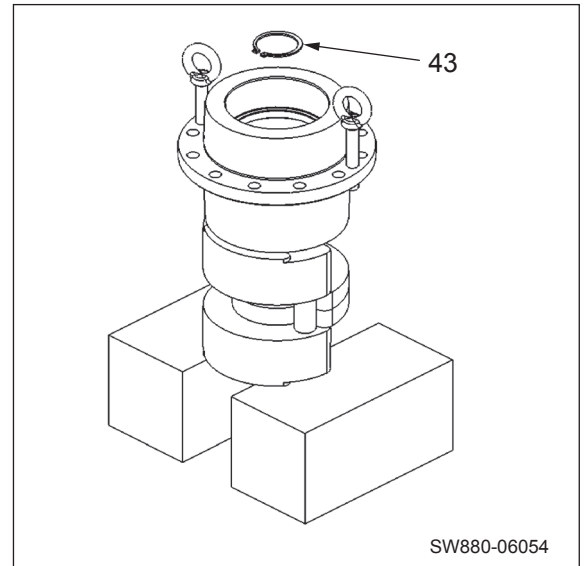

38) Lift the housing (8) with a crane to separate it from the eccentric shaft (4).

 Weight of housing : 40 kg (88 lbs.)

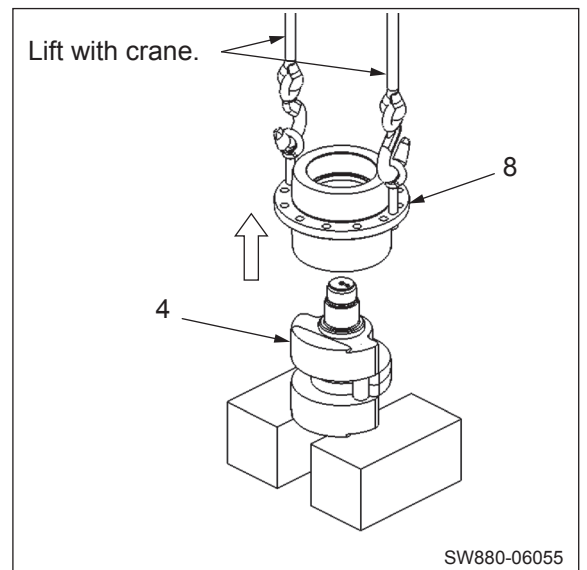

39) Put the housing (8) on wooden blocks.

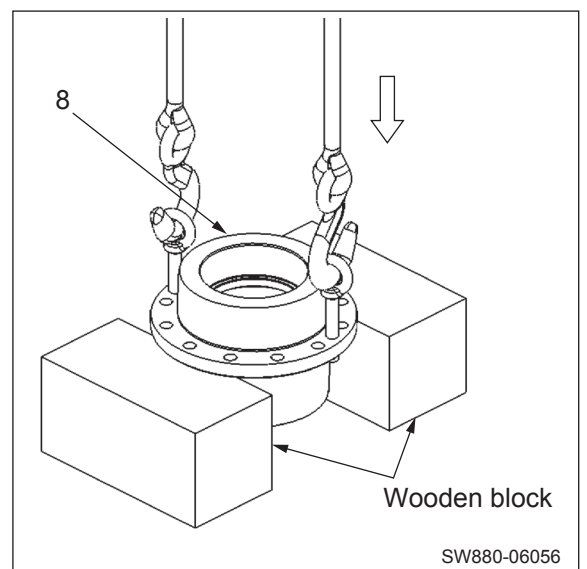

VIBRATORY DRUM

40) Tap on the bearing (5) with a hammer via a wooden bar or the like to remove it from the housing (8).

(NOTICE)

- Be careful not to damage the bearing.

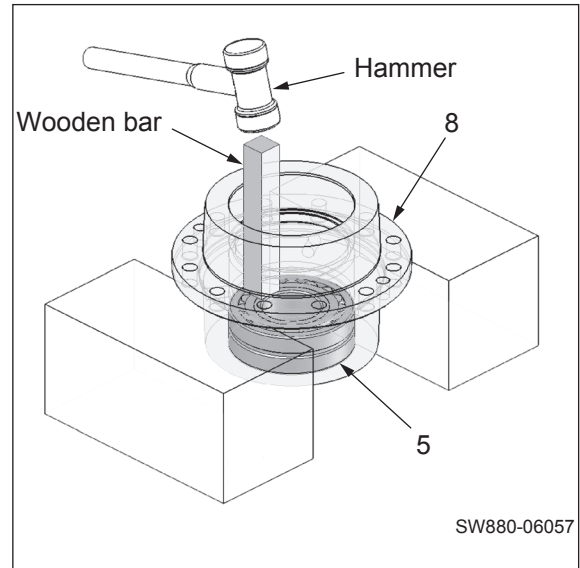

2-3-2. Reassembly of vibratory drum

(NOTICE)

- Before reassembling, clean the disassembled parts well and check that there is no abnormality.

1) Housing subassembly

- ① Apply a thin coat of gear oil to the surface to which the vibrator bearing (3) will be press-fitted.
 - Drive the vibrator bearing (3) into the housing (2).

(NOTICE)

- Take care not to damage the bearing when installing it.

- ② Apply a thin coat of grease to the O-ring (45).

- Install the O-ring (45) in the O-ring fitting groove in the housing (2).

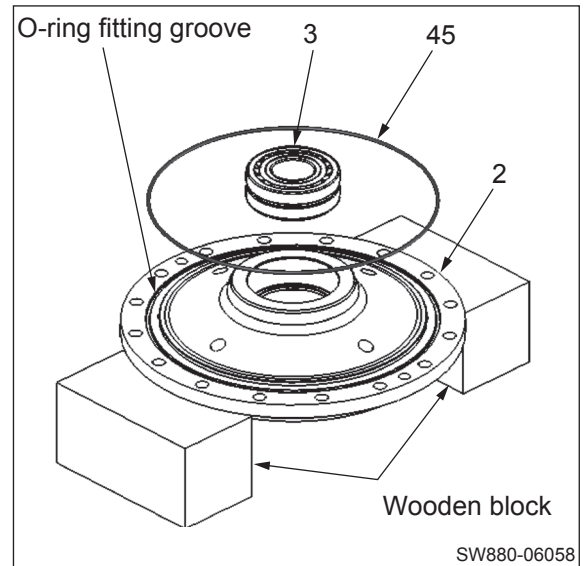

⚠ WARNING

When attaching the lifting bolts, screw in the threads fully before using.

- ③ Lift the housing subassembly with a crane and reverse it.
 - Install lifting bolts (M20×2.5).



Housing subassembly : 80 kg (176 lbs.)

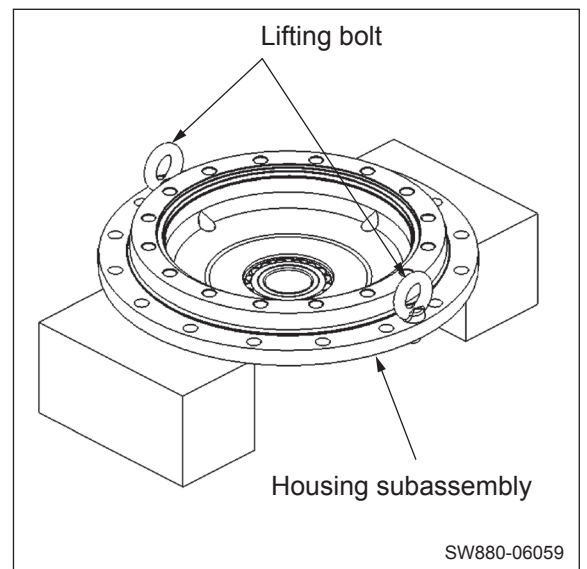

⚠ WARNING

When standing the drum, use wooden blocks of sufficient strength to securely support the drum.

- 2) Stand the drum (44) with its propulsion motor mounting side facing up.

(NOTICE)

- The side on which no $\varnothing 10$ round bar is installed is the propulsion motor side.



Drum (44)

SW880 : 2,070 kg (4,564 lbs.)

SW990 : 2,170 kg (4,784 lbs.)

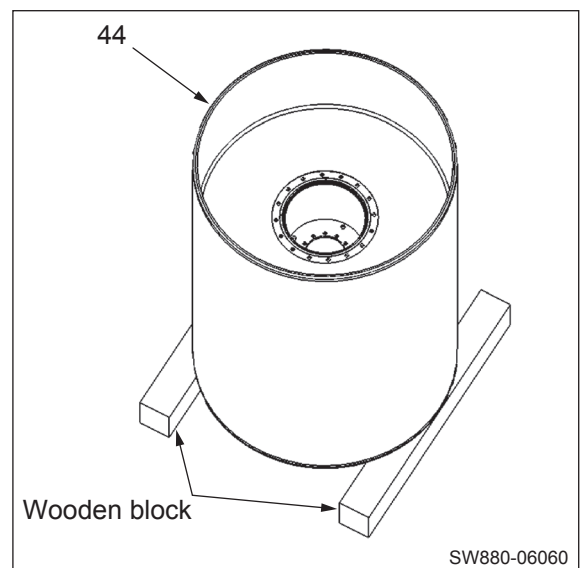

VIBRATORY DRUM

- 3) Lift the housing subassembly with a crane and install it in the vibratory drum.

(NOTICE)

- When installing the housing subassembly, take care not to allow the O-ring to protrude from the fitting groove.



Housing subassembly : 80 kg (176 lbs.)

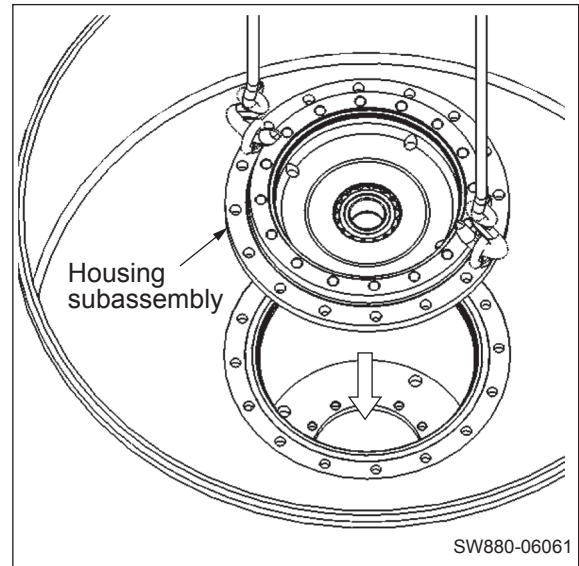

WARNING

Carry out the work in an unstrained posture using a work stool or the like.

- 4) Secure the housing subassembly to the drum with the sixteen bolts (1) and washers.



(1) M20×60 : 540 N·m (398 lbf·ft)

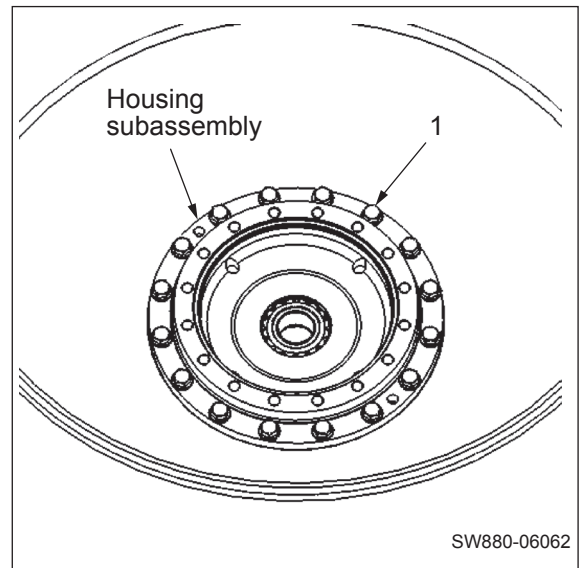

- 5) Attach a bearing inner race fixture to the housing subassembly with two bolts (M20×35) and washers.

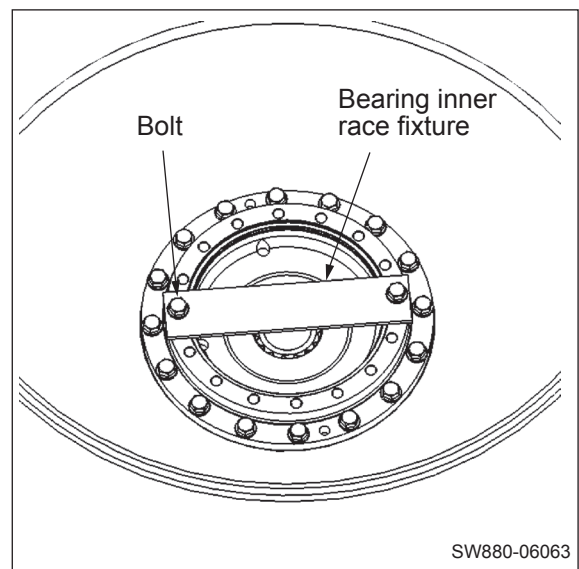
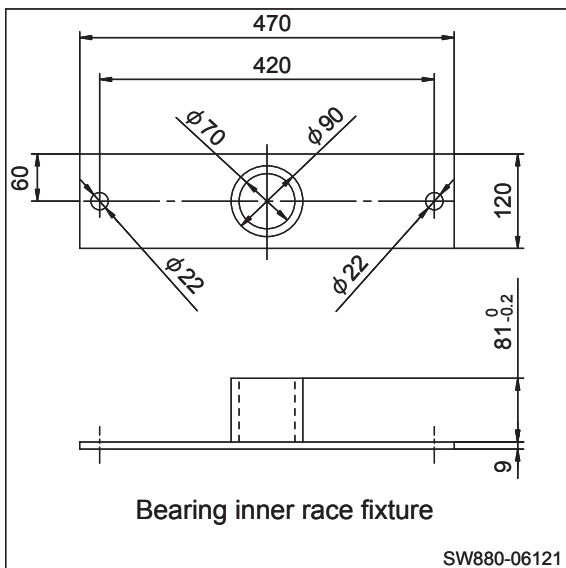

- 6) Shown on the right is a sectional view of the housing subassembly to which the bearing inner race fixture is attached.

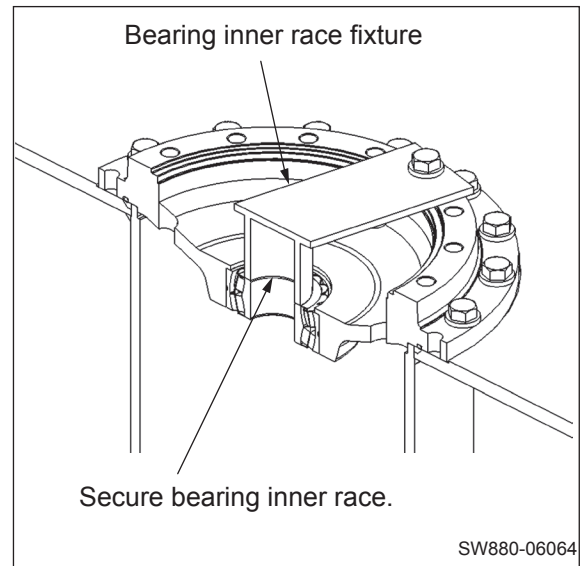

⚠ WARNING

Be careful because reversing the vibratory drum is dangerous work. Confirm that the surrounding area is safe, and work in a natural, unstrained posture.

- 7) Lift the drum (44) with a crane and reverse it. Then, stand the drum with its vibrator motor side facing up.

(NOTICE)

- The side on which a $\phi 10$ round bar is installed is the vibrator motor side.



Drum (44)

SW880 : 2,150 kg (4,740 lbs.)

SW990 : 2,250 kg (4,960 lbs.)

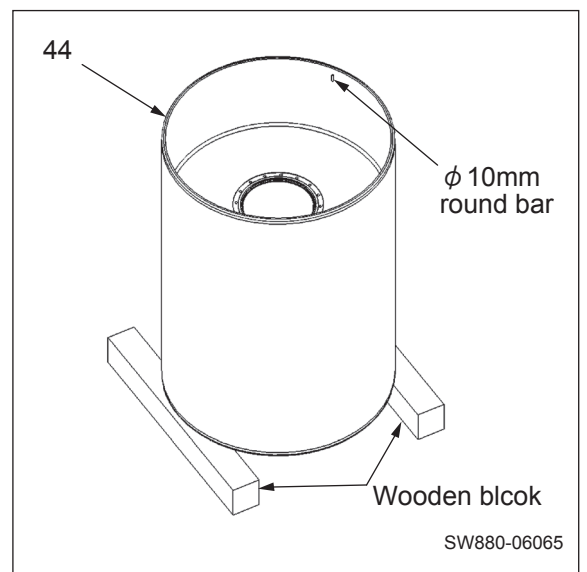

- 8) Put the eccentric shaft (11) (vibrator motor side) on wooden blocks with its splined portion facing up.
- Drive the spring pin (42) into the eccentric shaft.

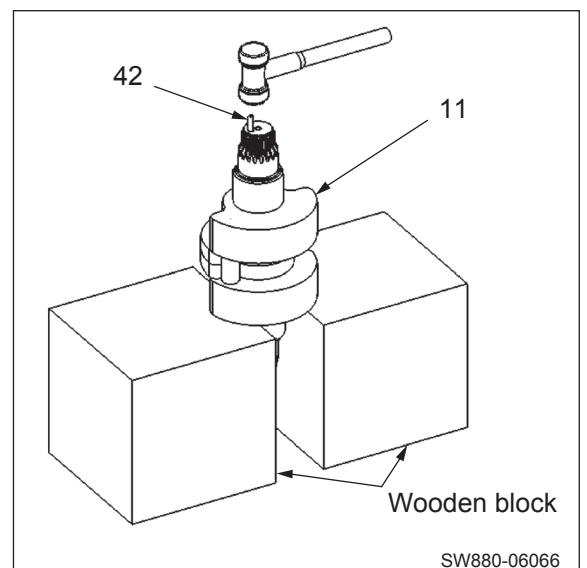

VIBRATORY DRUM

9) Eccentric shaft subassembly

- ① Apply a thin coat of gear oil to the surface to which the vibrator bearing (5) will be press-fitted.
 - Drive the vibrator bearing (5) into the housing (8).
 - Apply a thin coat of gear oil to the inner surface of the bearing (5).

(NOTICE)

- Take care not to damage the bearing when installing it.

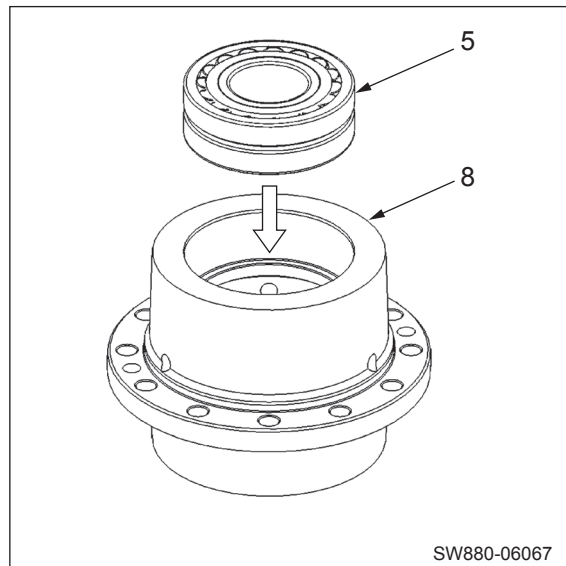

- ② Reverse the housing subassembly and install lifting bolts (M16×2.0) on it.

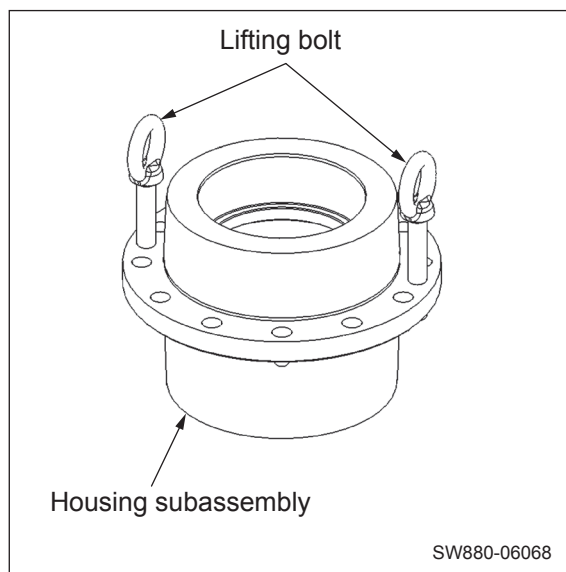

- ③ Put the eccentric shaft (4) (propulsion motor side) on the wooden blocks in place of the eccentric shaft (11) (vibrator motor side).

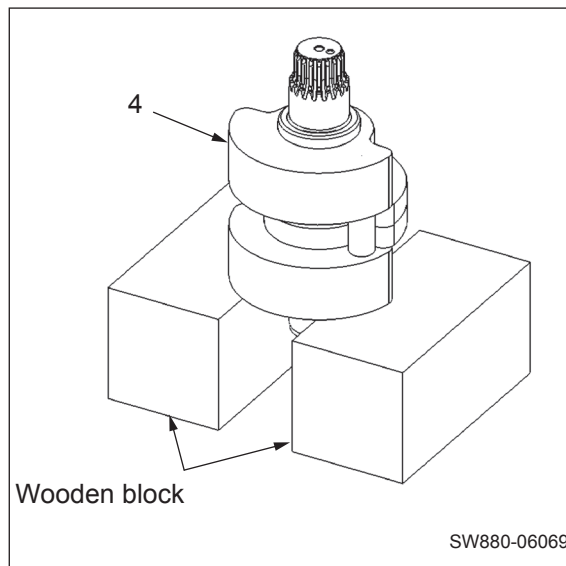

- ④ Apply a thin coat of gear oil to the bearing mounting surface of the eccentric shaft (4).
- Lift the housing subassembly with a crane and install it on the eccentric shaft (4).

(NOTICE)

- **Install the housing subassembly taking care not to tilt the vibrator bearing inner race.**



Housing subassembly : 40 kg (88 lbs.)

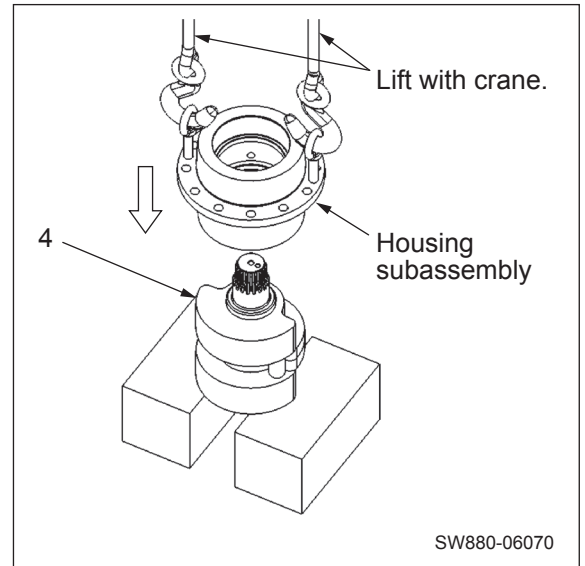

- ⑤ Install the snap ring (43) on the eccentric shaft (4).

(NOTICE)

- **Confirm that the snap ring (43) is securely fitted in the groove.**

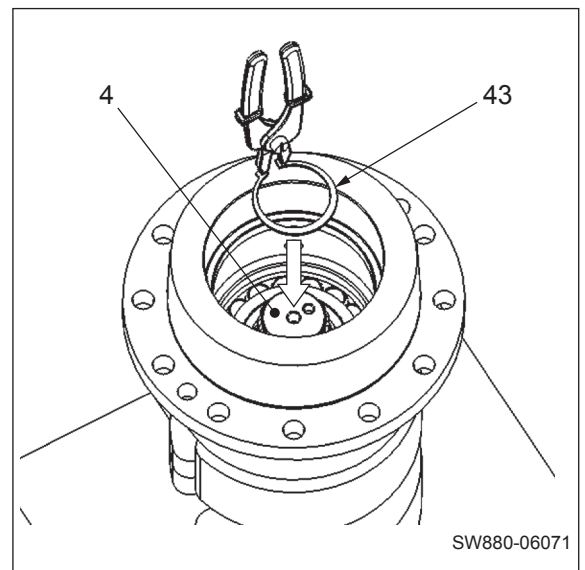

- ⑥ Drive the spring pin (7) into the sleeve (6).
- Apply gear oil to the inner surface of the sleeve (6) and the splined portion of the eccentric shaft (4).
- Install the sleeve (6) on the eccentric shaft (4).

(NOTICE)

- **When installing the sleeve (6), take care not to plug the positioning hole in the eccentric shaft (4) with the spring pin (7).**

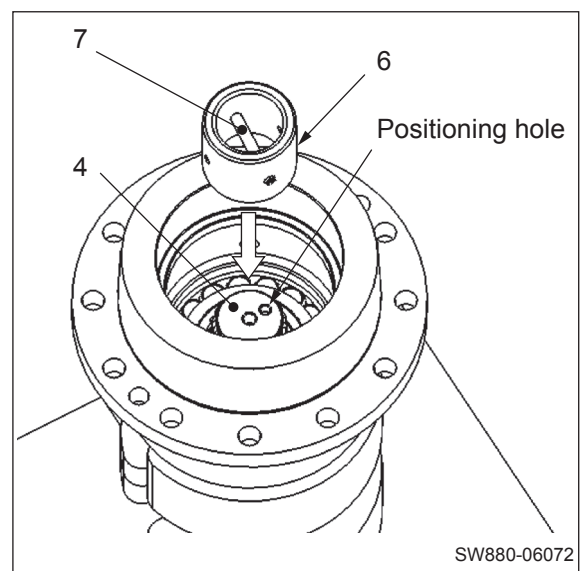

VIBRATORY DRUM

- ⑦ Apply a thin coat of gear oil to the surface to which the vibrator bearing (10) will be press-fitted.
- Drive the vibrator bearing (10) into the housing (8).

(NOTICE)

- Take care not to damage the bearing when installing it.

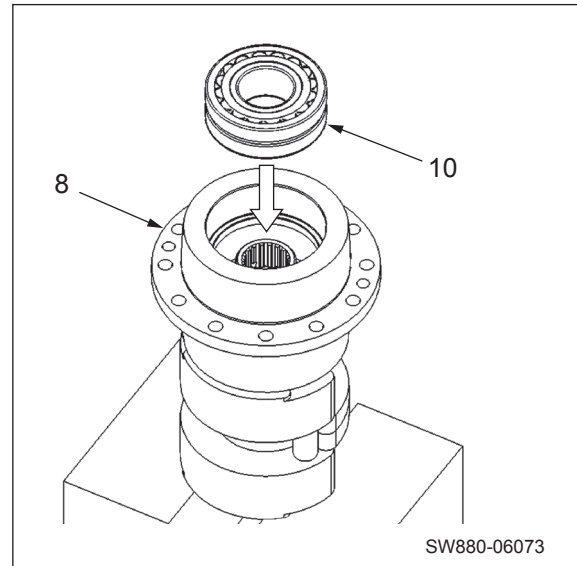

- ⑧ Install a lifting bolt (M8×1.25) on the shaft end of the eccentric shaft (11).
- Apply a thin coat of gear oil to the inner surface of the vibrator bearing (10) and the bearing mounting surface of the eccentric shaft (11).
 - Slowly lower the eccentric shaft (11) with a crane and install it in the housing (8).

(NOTICE)

- Install the housing subassembly taking care not to tilt the vibrator bearing inner race.



Eccentric shaft (11) : 60 kg (132 lbs.)

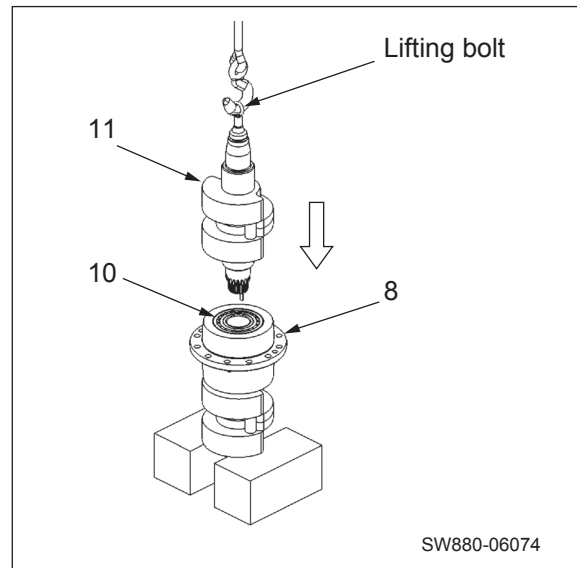

- ⑨ When installing the eccentric shaft (11) in the housing (8), insert the spring pin (42) on the shaft into the positioning hole in the eccentric shaft (4).

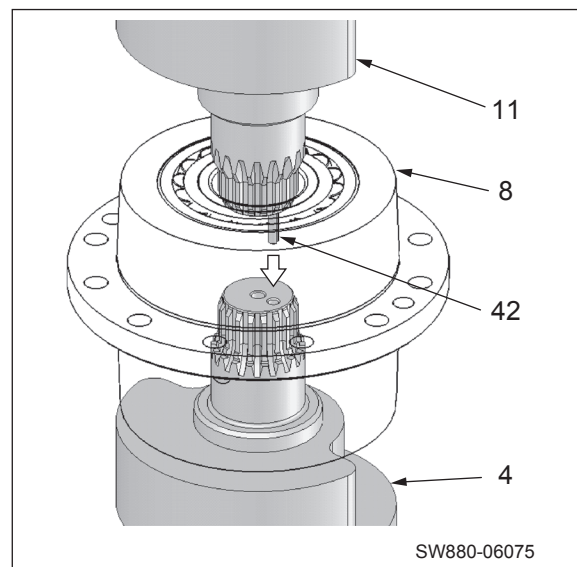

10) Attach a lifting jig to the eccentric shaft subassembly.

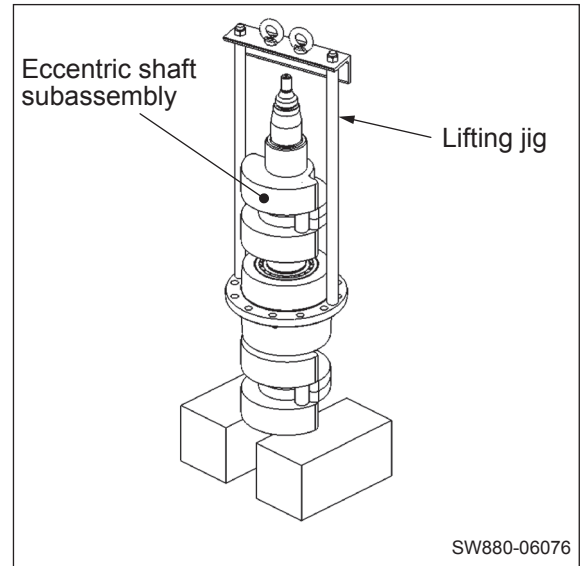
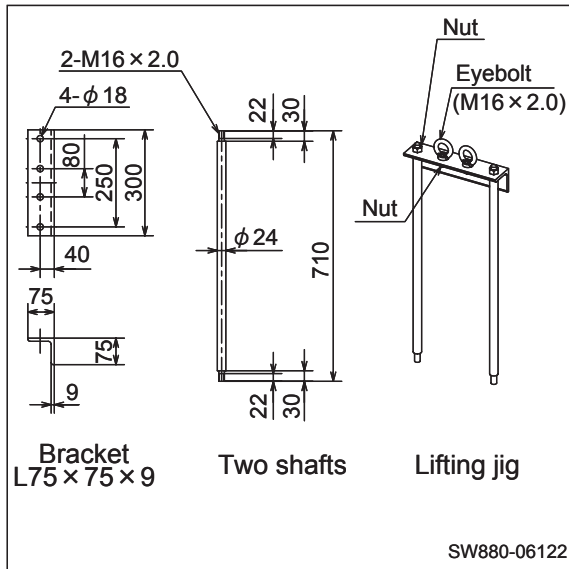

11) Apply gear oil to the bearing mounting surface of the eccentric shaft.

- Slowly lift the eccentric shaft subassembly with a crane and install it in the drum (44).



Eccentric shaft subassembly : 150 kg (331 lbs.)

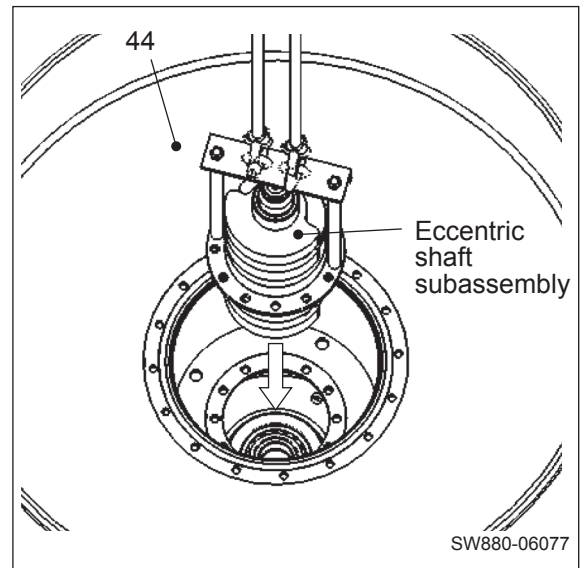

12) Secure the eccentric shaft subassembly to the drum with the twelve bolts (9) and washers.



(9) M16×50 : 265 N·m (195 lbf·ft)

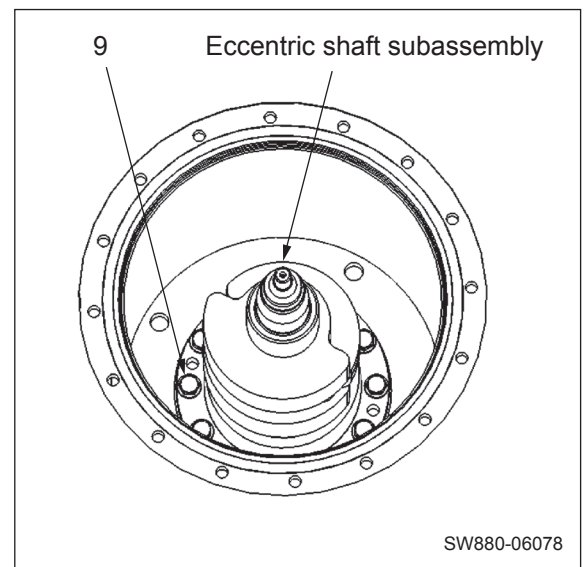

VIBRATORY DRUM

13) Axle shaft subassembly

13-1) Apply a thin coat of gear oil to the surface of the outer race of the roller bearing (36) to be press-fitted.

- Drive the outer race of the roller bearing (36) into the housing (15).
- Install the oil seal (37).
- Apply a thin coat of grease to the lip surface of the oil seal (37).

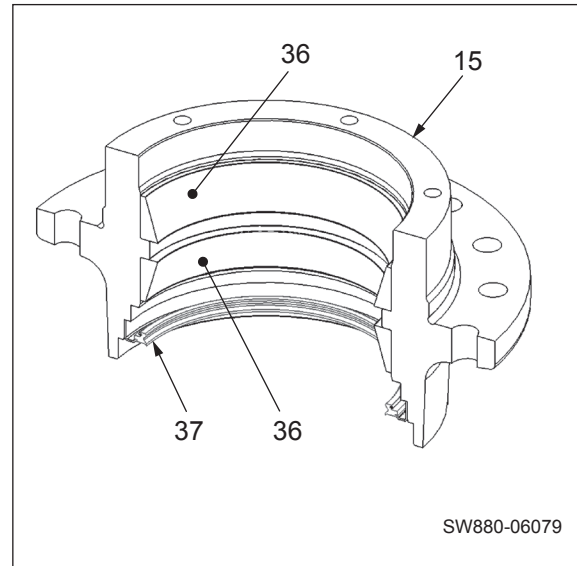

13-2) Apply a thin coat of gear oil to the surface of the vibrator bearing (12) to be press-fitted.

- Drive the vibrator bearing (12) into the axle shaft (13).

(NOTICE)

- Take care not to damage the bearing when installing it.

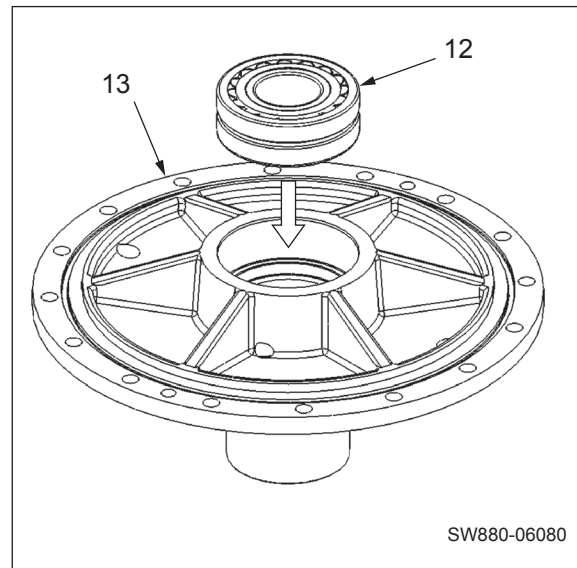

13-3) Lift the axle shaft subassembly with a crane and reverse it.

- Apply a thin coat of gear oil to the surface of the inner race of the roller bearing (36) to be press-fitted.
- Install the inner race of the roller bearing (36).

 Axle shaft subassembly : 80 kg (176 lbs.)

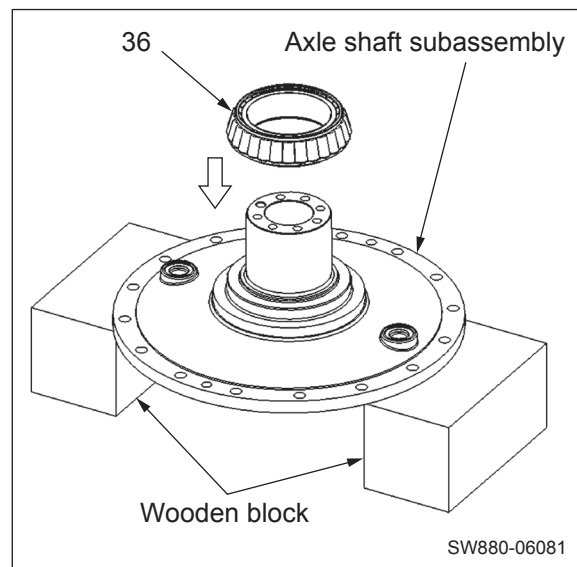

- 13-4) Install the plugs (38) on the axle shaft subassembly.
- Apply sufficient amount of lithium-based grease to the roller surface of the roller bearing (36).

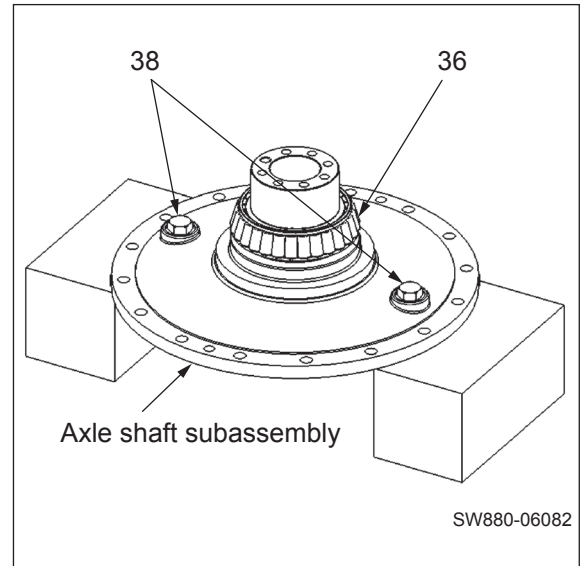

- 13-5) Install lifting bolts (M12×1.75) on the housing subassembly and lift it with a crane to joint it with the axle shaft subassembly.

 Housing subassembly : 50 kg (110 lbs.)

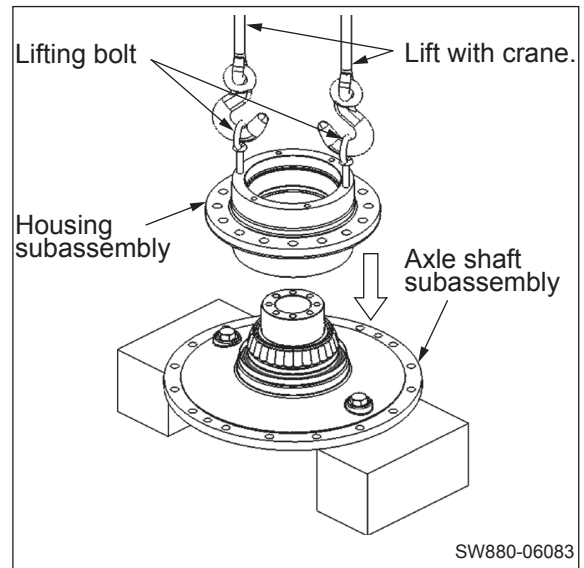

- 13-6) Apply sufficient amount of lithium-based grease to the roller surface of the inner race of the roller bearing (36).
- Drive the roller bearing (36) into the housing subassembly until the roller surface of its inner race comes into contact with the outer race.

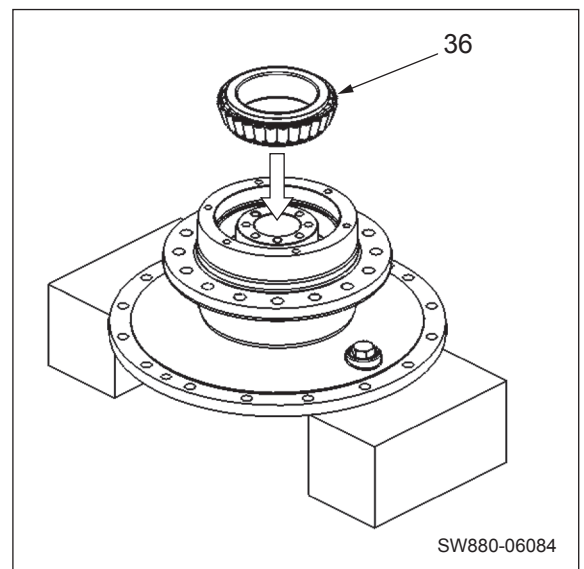

VIBRATORY DRUM

13-7) Preload adjustment of roller bearing

- ① Install a shim (26) of about 1 mm on the axle shaft and install the cover (29). The shim provides a clearance between the end face of the axle shaft and the inner surface of the cover (29).
 - Tighten the four bolts (28) with washers to a torque of 108 N·m.
 - Give the housing (15) two to three turns and tighten the bolts to a torque of 108 N·m again.
 - Repeat this work several times until the tightening torque of the bolts no longer fluctuates.

(NOTICE)

- **Tighten four of the eight bolts (28) alternately in the diagonal directions.**

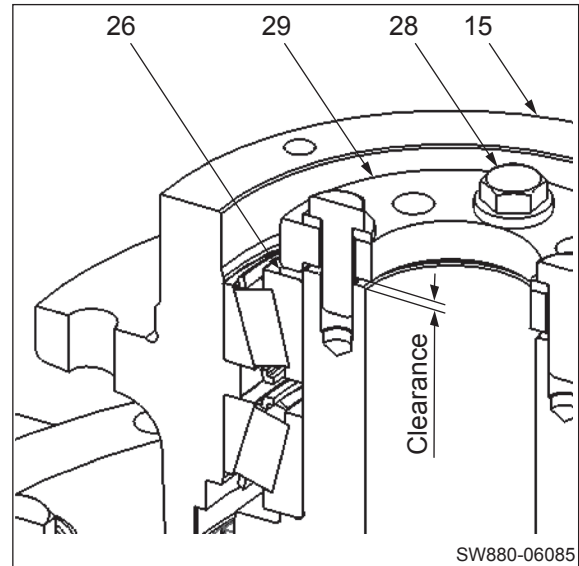

- ② Remove the four bolts (28).
 - Remove the cover (29) and shim (26).

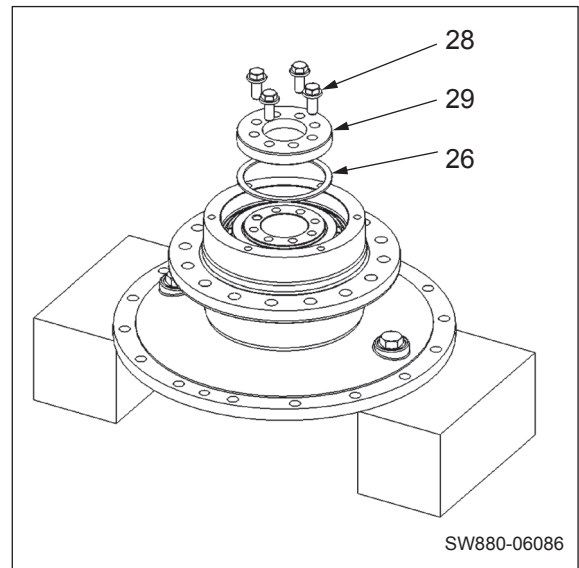

- ③ Install the cover (29) without the shim and tighten the four bolts (28) with washers.
 - Measure clearance A with a thickness gauge.

★ Preload adjusting shim amount = $(A + 0.1 \text{ mm})$

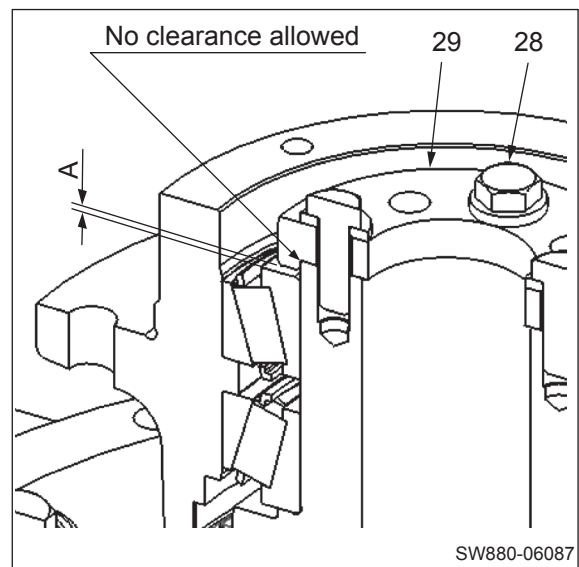

④ Remove the four bolts (28).

- Remove the cover (29).
- Install a shim of the preload adjusting shim amount “A + 0.1 mm” and reinstall the cover (29). Then, secure the cover with the eight bolts (28) with washers.

 (28) M14×40 : 167 N·m (123 lbf·ft)

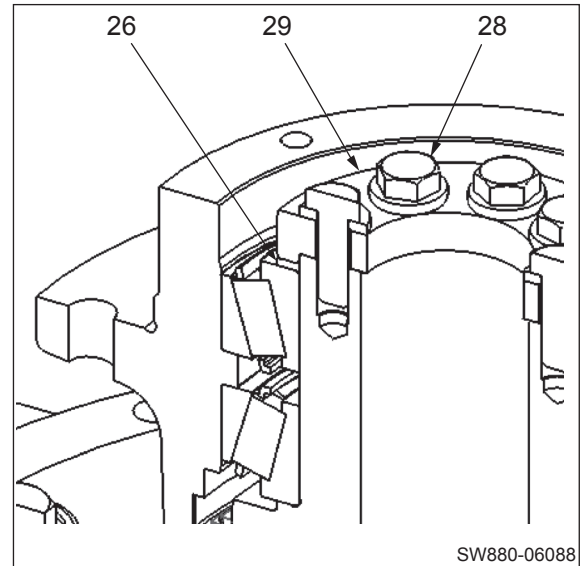

⑤ Install the oil seal (25) on the cover (34).

- Apply a thin coat of grease to the lip surface of the oil seal (25).
- Apply liquid packing to the mounting surface.

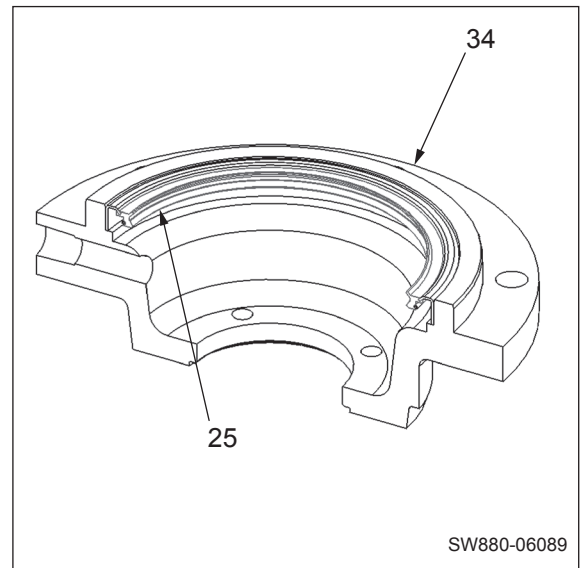

⑥ Secure the cover (34) to the housing (15) with the six bolts (35) and spring washers.

 (35) M12×40 : 108 N·m (80 lbf·ft)

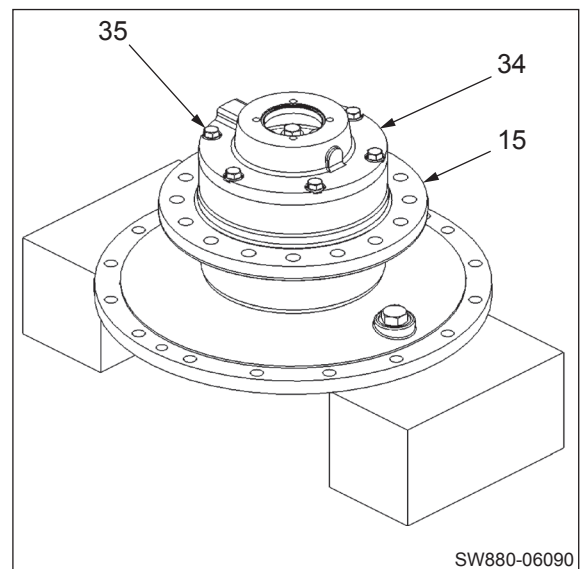

VIBRATORY DRUM

14) Install lifting bolts (M16×2.0) on the axle shaft subassembly.

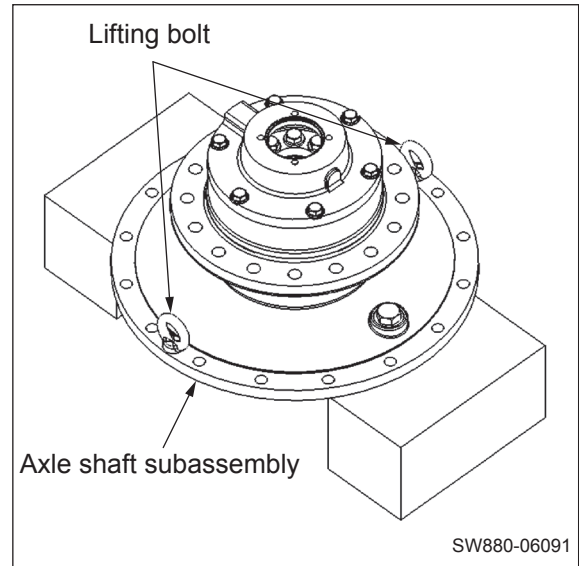

15) Apply a thin coat of grease to the entire periphery of the O-ring (39).
• Install the O-ring (39) on the axle shaft subassembly.

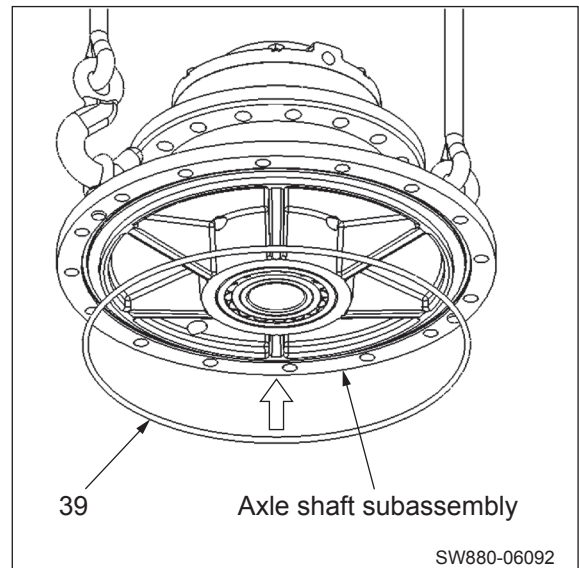

16) Lift the axle shaft subassembly with a crane and lower it slowly.
• Supporting the eccentric shaft (11) with a pipe or the like, align the center of the vibrator bearing inner race to that of the shaft.

(NOTICE)

- Install the axle shaft taking care not to tilt the vibrator bearing.
- When installing the axle shaft, take care not to allow the O-ring to protrude from the fitting groove.

 Axle shaft subassembly : 140 kg (309 lbs.)

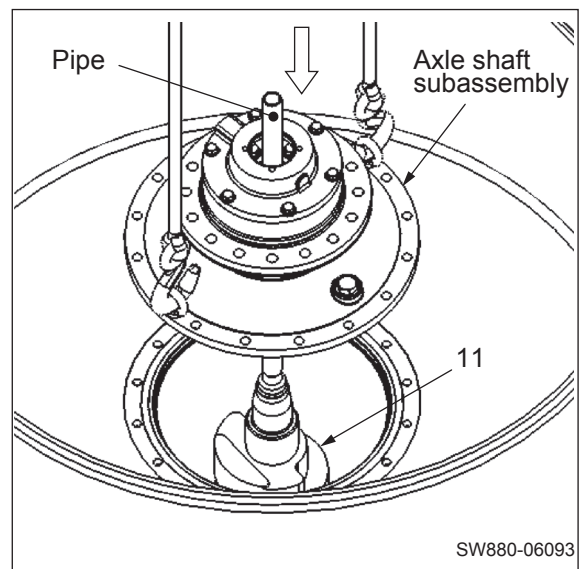

(NOTICE)

- When installing the axle shaft subassembly, pay attention to the positional relationship between the $\phi 10$ round bar on the drum and the plugs (38-1) and (38-2).

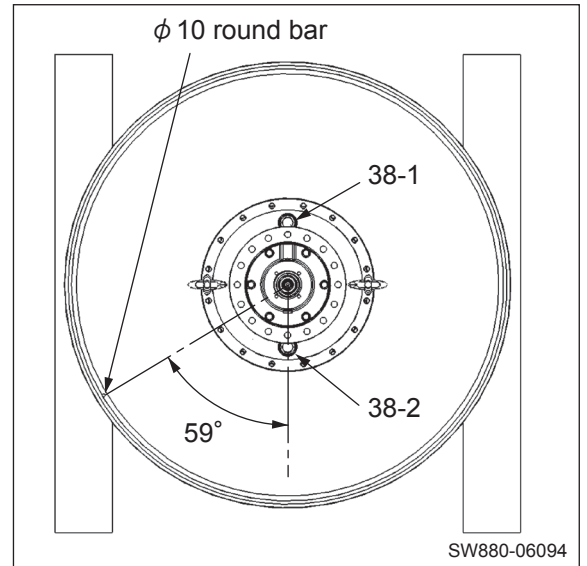

- 17) Secure the axle shaft subassembly to the drum with the sixteen bolts (14).

 (14) M16×50 : 265 N·m (195 lbf·ft)

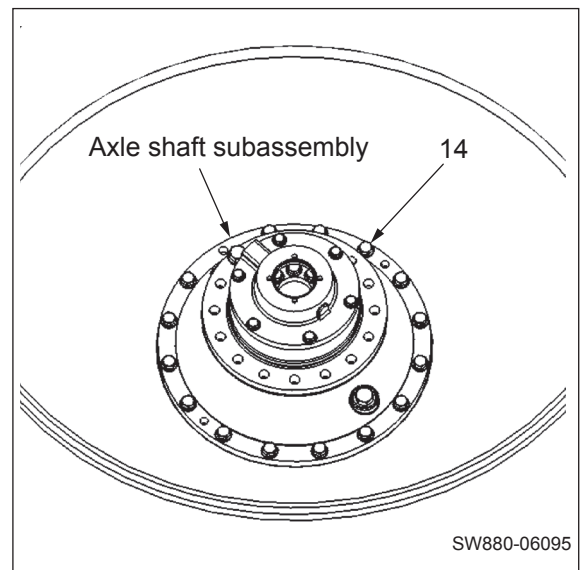

- 18) Install a lifting bolt (M8×1.25) on the shaft end of the eccentric shaft (11).

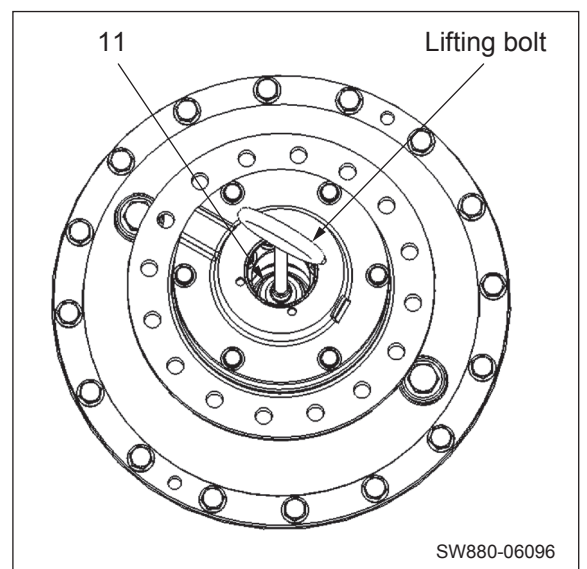

VIBRATORY DRUM

19) Slowly lift the eccentric shaft with a crane and check that there is an axial play of 1 to 2 mm.

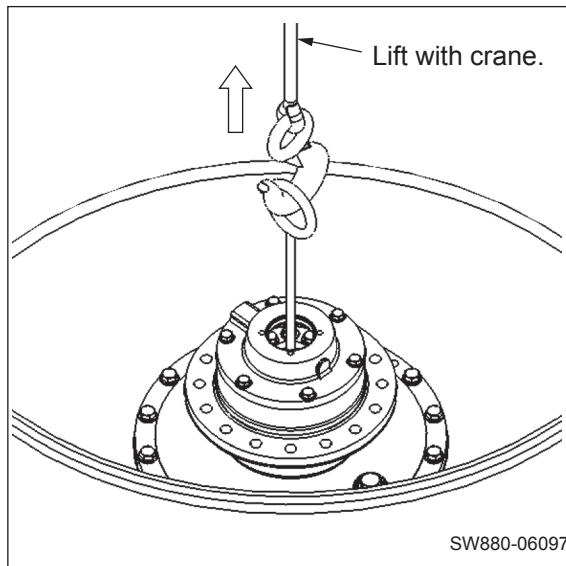

20) Install lifting bolts and nuts (M22×2.5) on a subassembly of the brackets (16), (22) and (32) and dampers (18) as shown on the right.

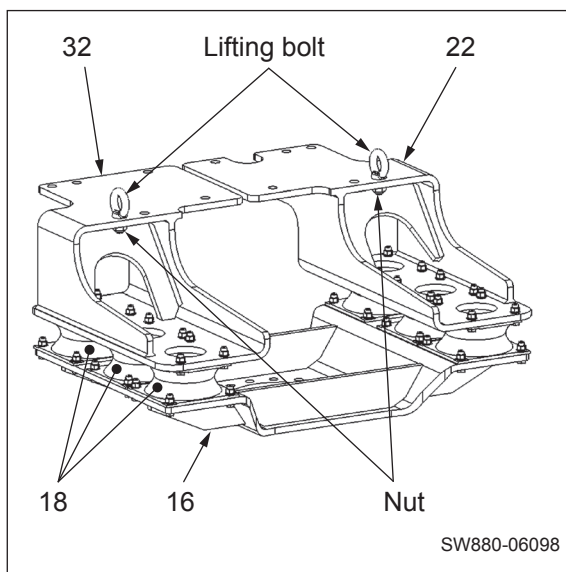

21) Lift the bracket subassembly with a crane.



Bracket subassembly : 290 kg (639 lbs.)

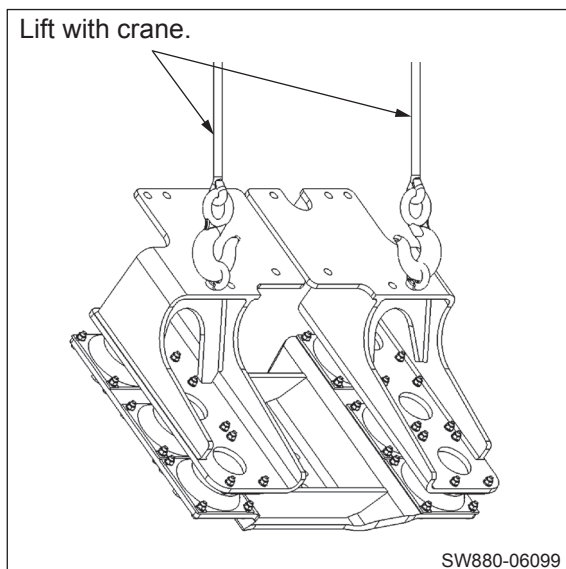

22) Lower the bracket subassembly while keeping it level and install it on the spigot joint of the housing.

(NOTICE)

- Be sure to install the bracket subassembly correctly in relation to the position of the breather mounting hole in the housing.

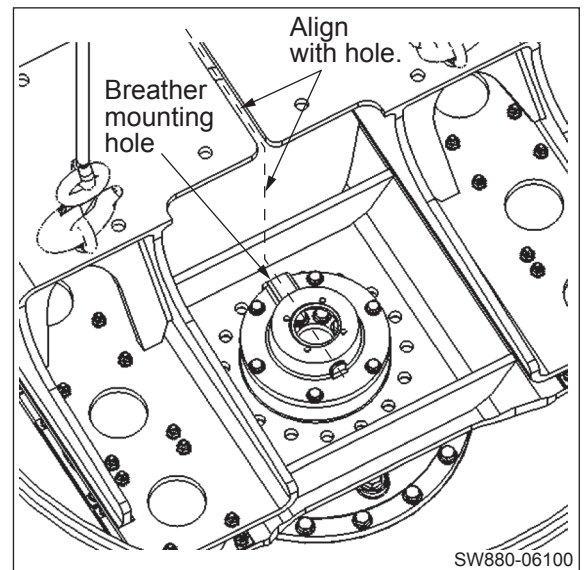

23) Secure the bracket subassembly to the housing with the sixteen bolts (23) and washers.

 (23) M16×50 : 265 N·m (195 lbf·ft)

- Wind seal tape around the threaded portion of the breather (24).
- Install the breather (24).

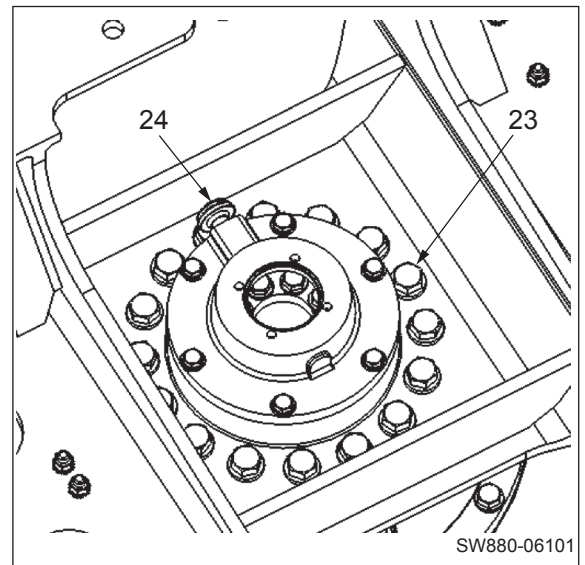

24) Apply molybdenum-based grease to the splined portion of the sleeve (40).

- Fit the sleeve (40) to the splined shaft on the eccentric shaft end.

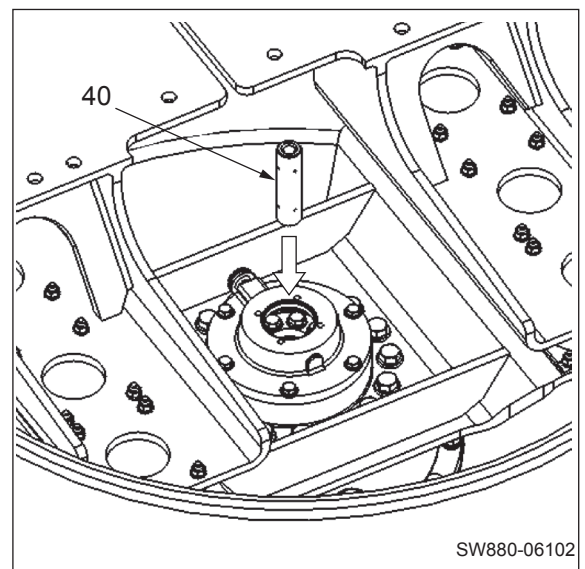

VIBRATORY DRUM

- 25) Apply a thin coat of grease to the O-ring (33).
- Install the O-ring (33) on the vibrator motor (27).

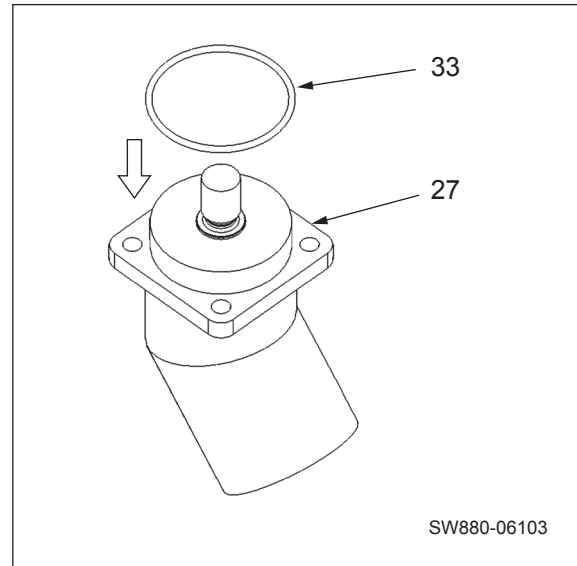

- 26) Secure the vibrator motor (27) in place with the four bolts (30).

(NOTICE)

- When installing the vibrator motor, take care not to allow the O-ring to protrude from the fitting groove.

 (30) M10×30 : 60 N·m (44 lbf-ft)

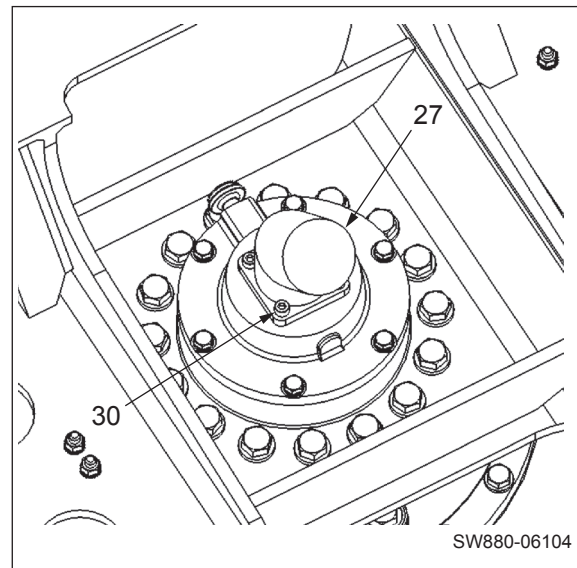

⚠ WARNING

Be careful because reversing the vibratory drum is dangerous work. Confirm that the surrounding area is safe, and work in a natural, unstrained posture.

- 27) Lift the drum (44) with a crane and reverse it. Then, stand the drum with the propulsion motor side facing up.

 Drum (44)
SW880 : 2,690 kg (5,930 lbs.)
SW990 : 2,760 kg (6,085 lbs.)

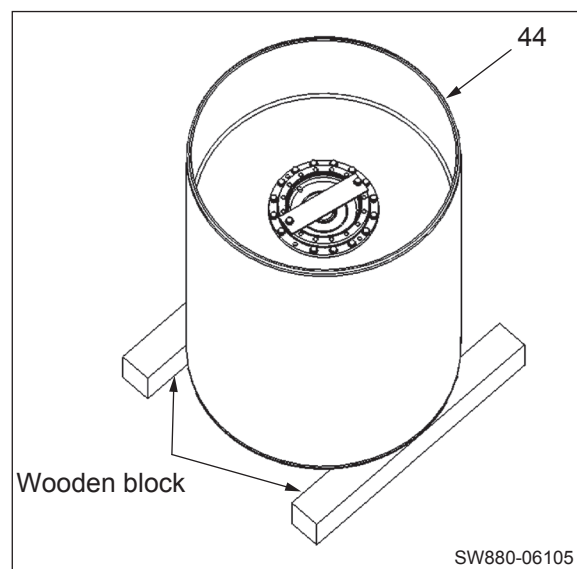

28) Remove the bearing inner race fixture.

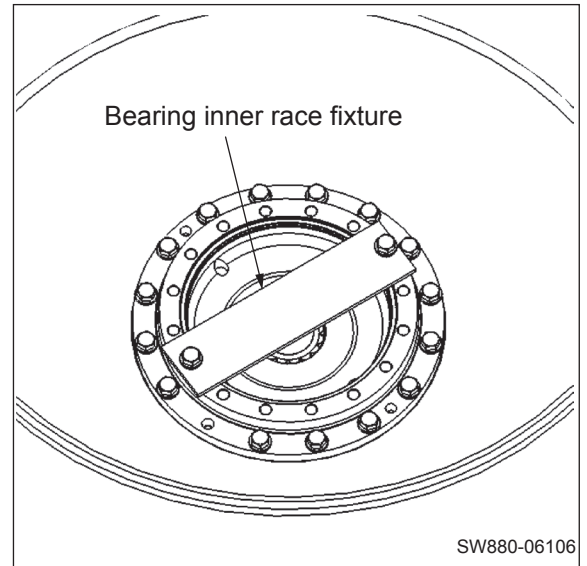

29) Install a lifting bolt (M10×1.5) on the shaft end of the eccentric shaft (4).

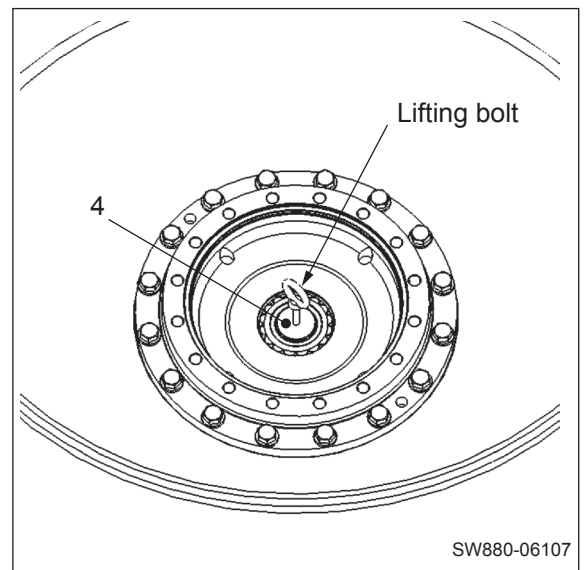

30) Slowly lift the eccentric shaft with a crane and check that there is an axial play of 1 to 2 mm.

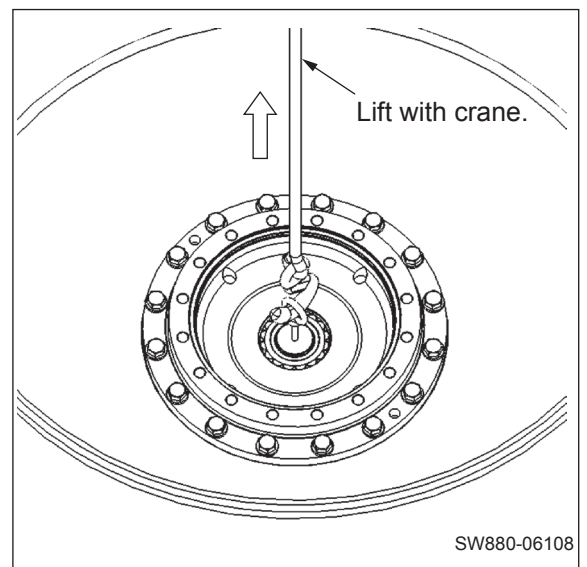

VIBRATORY DRUM

31) Apply a thin coat of grease to the O-ring (50).

- Install the O-ring (50) on the propulsion motor (51).

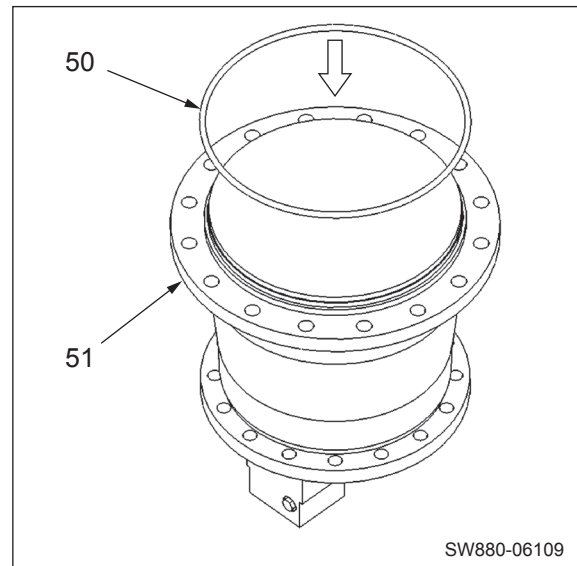

32) Install lifting bolts (M16×2.0) on the propulsion motor (51).

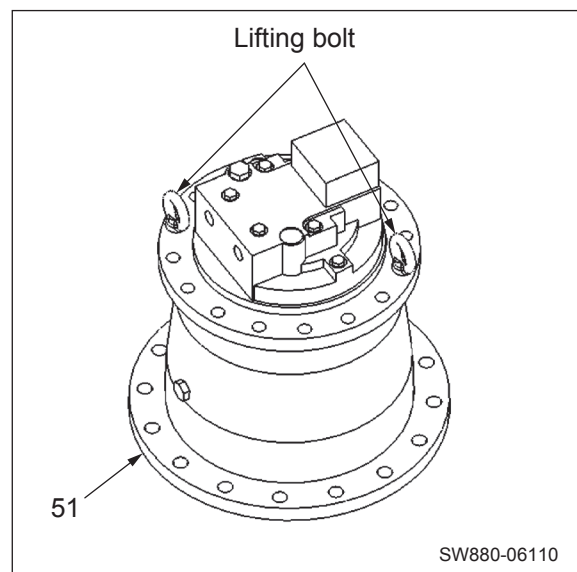

33) Slowly lift the propulsion motor (51) with a crane and install it in the drum.

(NOTICE)

- When installing the propulsion motor, take care not to allow the O-ring to protrude from the fitting groove.



Propulsion motor (51) : 200 kg (441 lbs.)

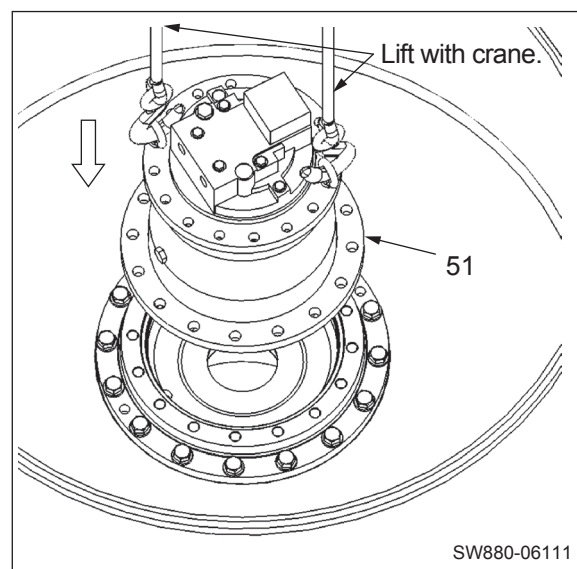

(NOTICE)

- When installing the propulsion motor (51), pay attention to the positional relationship with the vibrator motor (27).

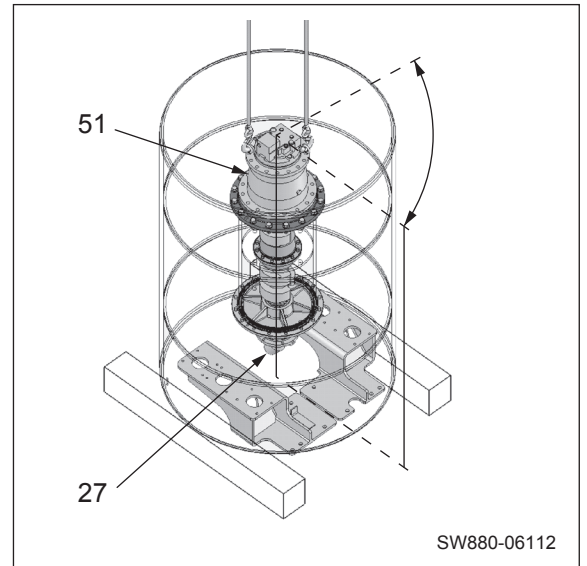

SW880-06112

- 34) Secure the propulsion motor (51) with the bolts (48) and washers.

 (48) M20×60 : 540 N·m (398 lbf·ft)

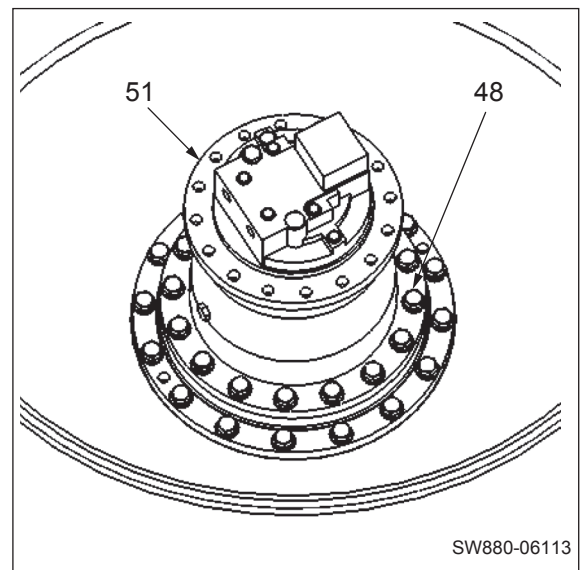

SW880-06113

- 35) Install lifting bolts and nuts (M22×2.5) on a subassembly of the brackets (46) and (54), plate (53) and dampers (57) as shown on the right.

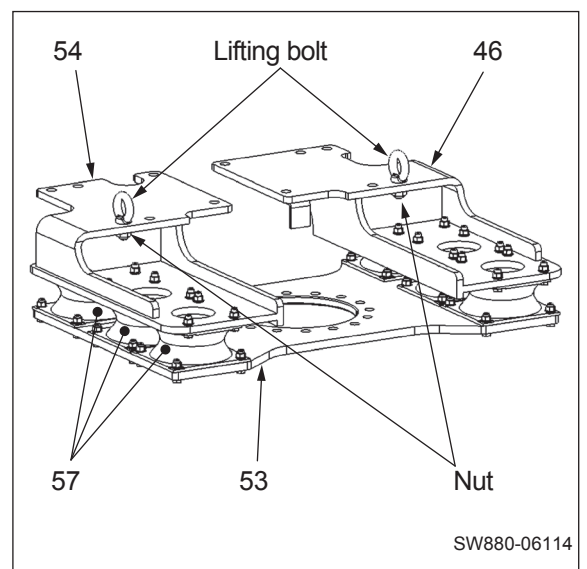

SW880-06114

VIBRATORY DRUM

36) Lift the bracket subassembly with a crane.

 Bracket subassembly : 250 kg (551 lbs.)

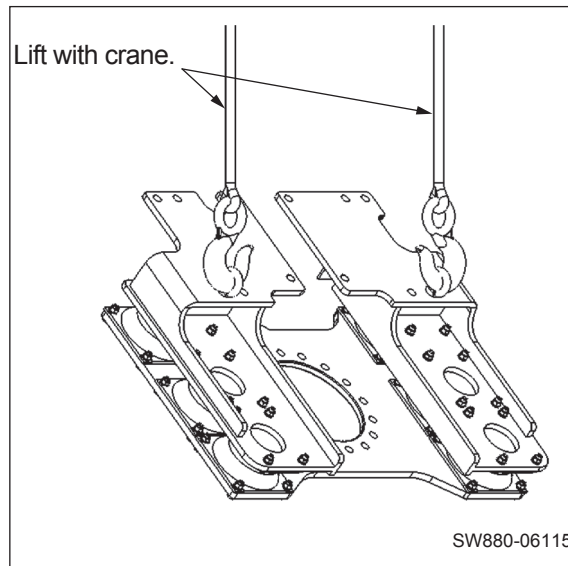

37) Lower the bracket subassembly while keeping it level and install it on the spigot joint of the propulsion motor (5).

(NOTICE)

- Be sure to install the bracket subassembly correctly in relation to the position of the propulsion motor (51).

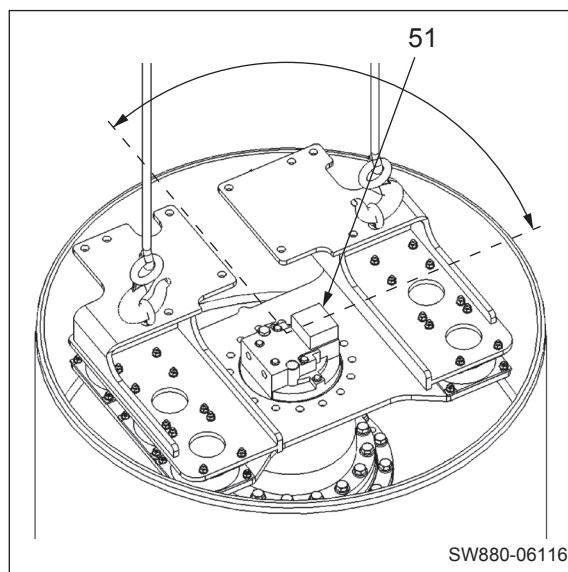

38) Secure the bracket subassembly to the propulsion motor (51) with the sixteen bolts (52) and washers.

 (52) M20×60 : 540 N·m (398 lbf·ft)

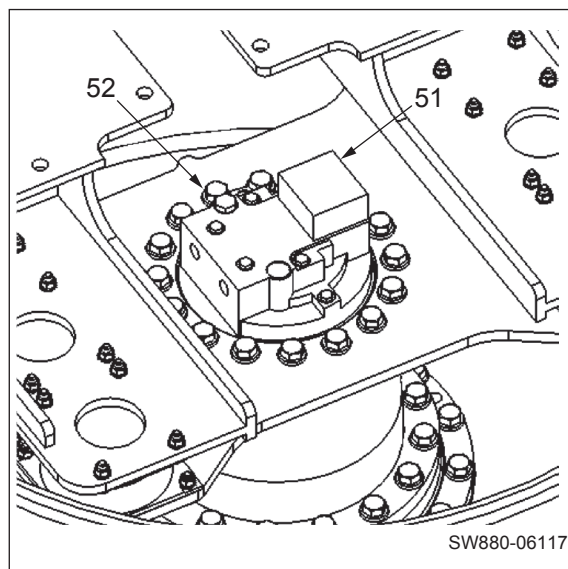

39) Lift the assembled drum assembly with a crane and lay it with the $\phi 10$ round bar on the vibrator motor side facing down.

- Hold the drum assembly in place with chocks.



Drum assembly

SW880 : 3,100 kg (6,834 lbs.)

SW990 : 3,215 kg (7,088 lbs.)

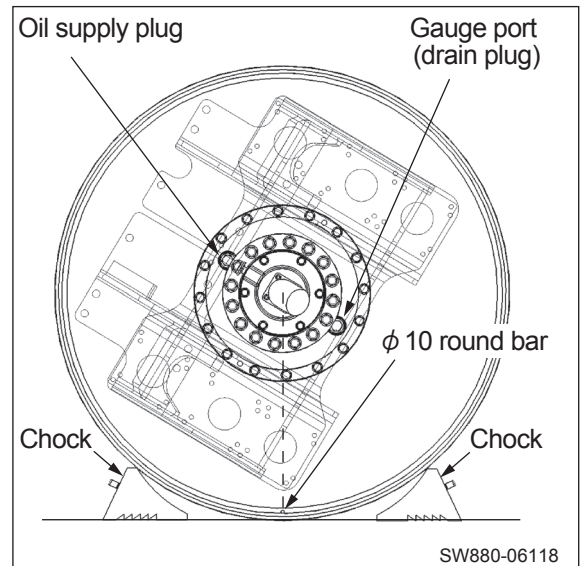

40) Remove the plugs (38-1) and (38-2).

- Supply gear oil from the oil supply port and check that the oil drips from the gauge port.
- Gear oil : 22 L (5.8 gal.)
- Reinstall the plugs (38-1) and (38-2).

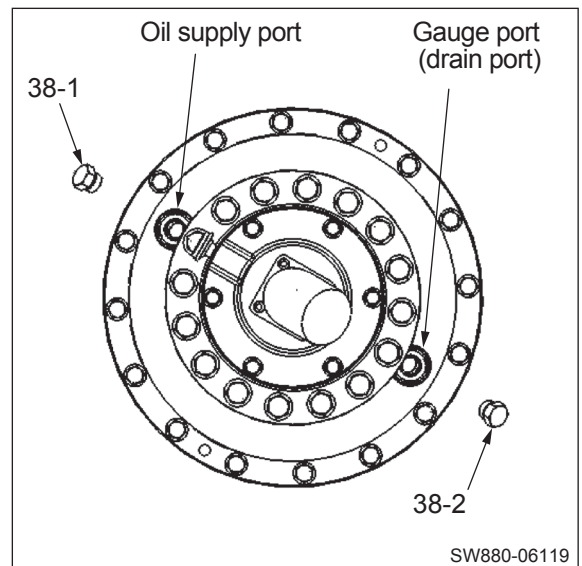

BRAKES

1. BRAKE SYSTEM

1-1. Brake Pedal

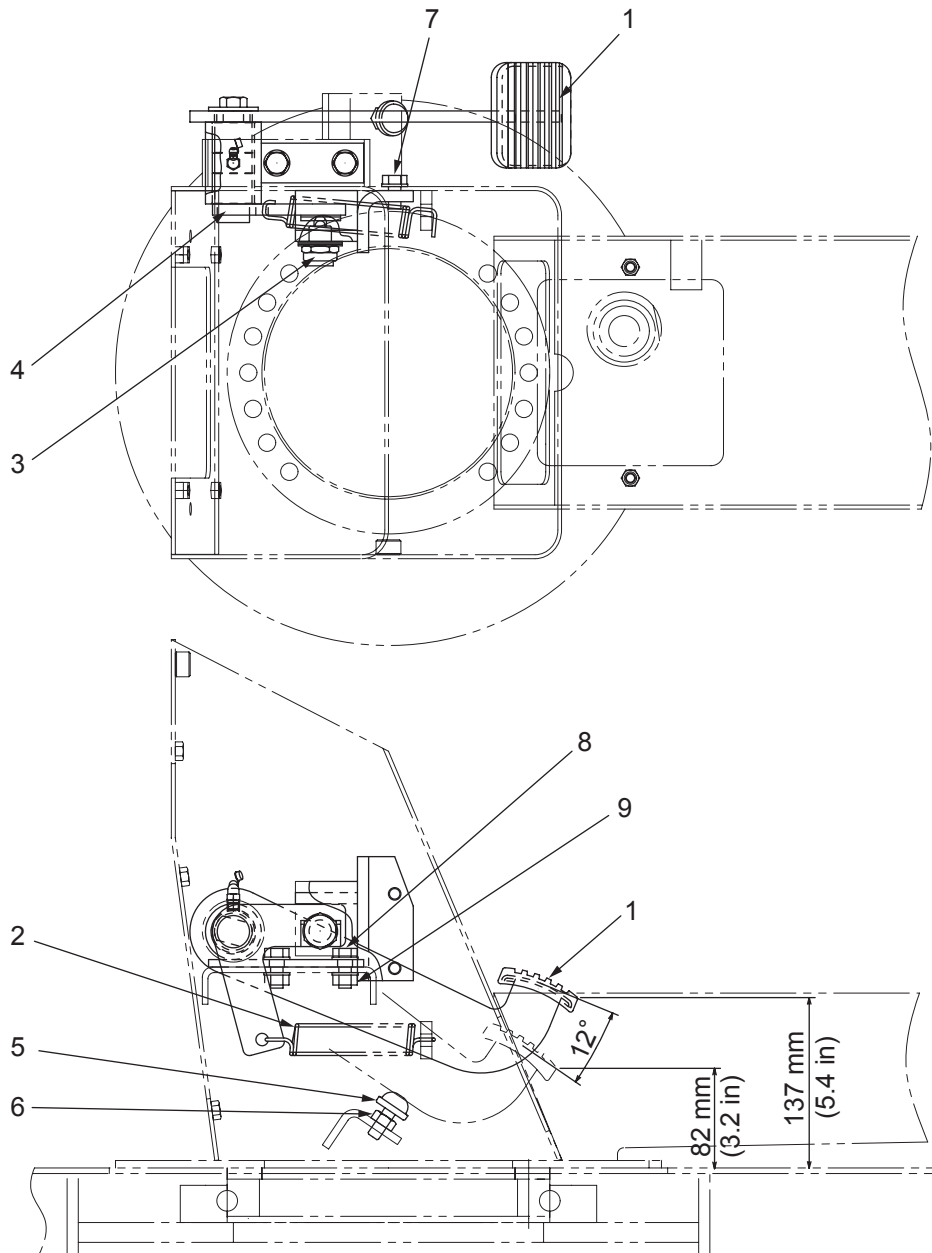

0568-51801-0-10036-A

- (1) Brake pedal
- (2) Return spring
- (3) Foot brake switch
- (4) Lever
- (5) Stopper bolt (M10×25 P1.25)
- (6) Nut (M10 P1.25)
- (7) Bolt (M10×20)
- (8) Bolt (M10×25)



(9) Nut (M10) : 49 N·m (36 lbf·ft)

1-2. Brake Circuit Configuration

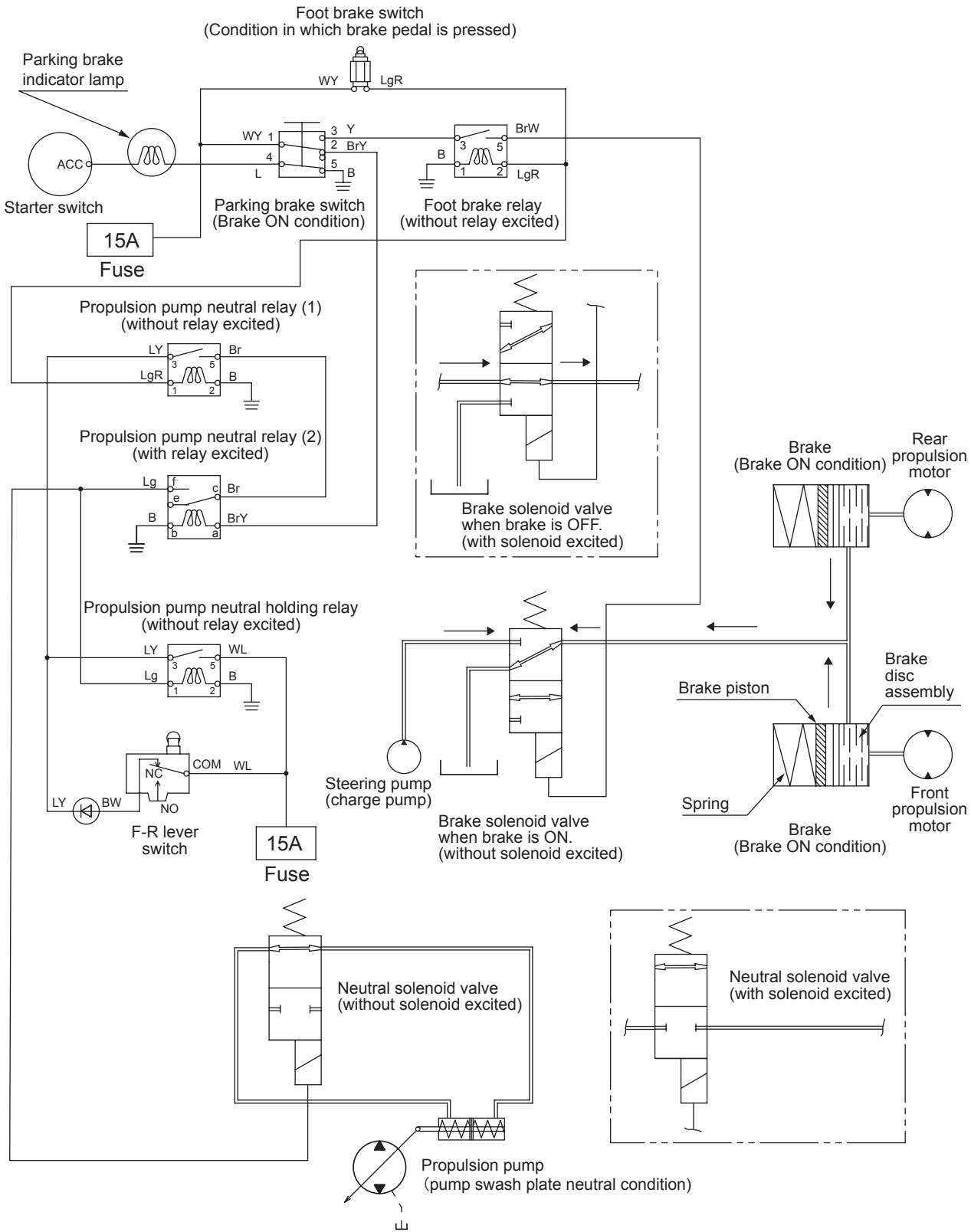

• The arrow (→) symbol shows the direction of the hydraulic oil flow.

SW880-07001

OPERATOR STATION

1. FLOORBOARD

1-1. Operator Station

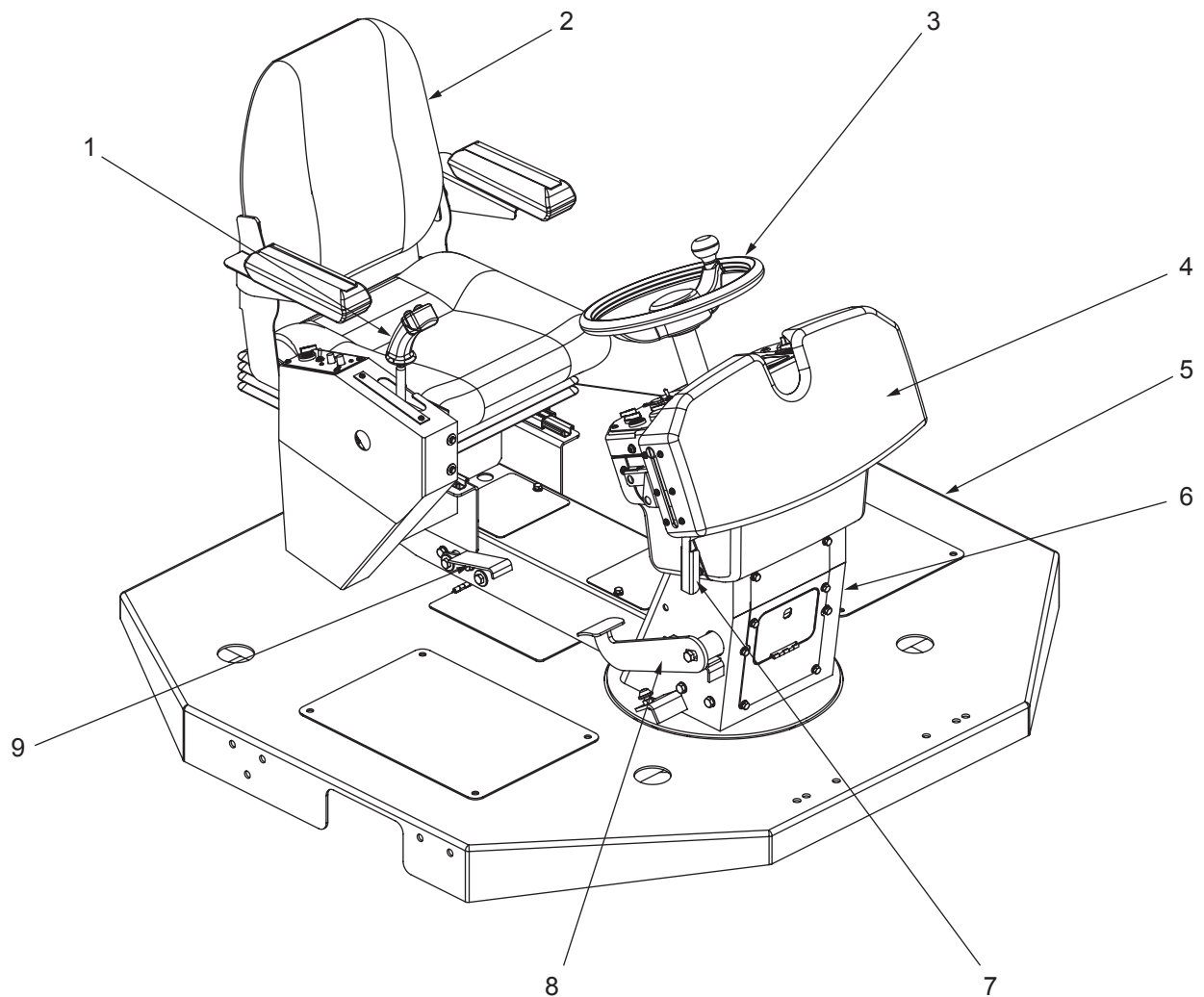

SW880-08001

- (1) Forward-reverse lever
- (2) Seat
- (3) Steering wheel
- (4) Cover
- (5) Floorboard
- (6) Dashboard
- (7) Tilt lock lever
- (8) Brake pedal
- (9) Swivel lock release pedal

1-2. Structure of Operator Station

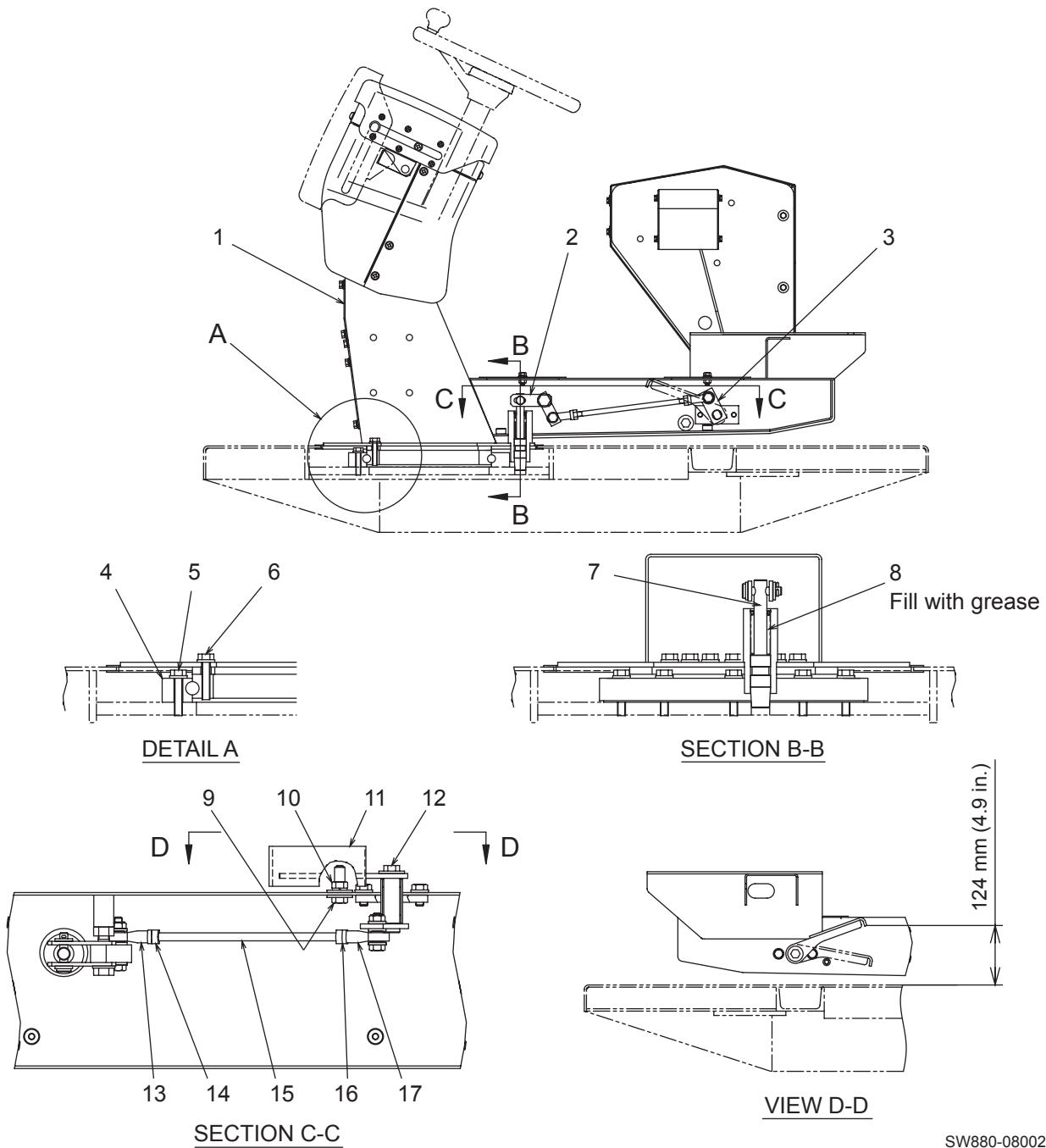

SW880-08002

- | | |
|---------------------------------|--------------------------------------|
| (1) Dashboard | (10) Nut M10 |
| (2) Lever | (11) Pedal |
| (3) Pin | (12) Bolt M10×20 |
| (4) Swing bearing | (13) Rod end (right-hand thread) |
| (5) Bolt M10×50 | (14) Locknut (right-hand thread) M10 |
| (6) Bolt M10×50 | (15) Tie rod |
| (7) Pin | (16) Locknut (left-hand thread) M10 |
| (8) Spring | (17) Rod end (left-hand thread) |
| (9) Bolt (pedal stopper) M10×40 | |



- (5) Bolt M10×50 : 49 N·m (36 lbf·ft)
 (6) Bolt M10×50 : 49 N·m (36 lbf·ft)
 (12) Bolt M10×20 : 49 N·m (36 lbf·ft)

1-3. Adjustment of Swivel Lock Release Pedal

- ① Loosen the locknuts (14) and (16).
- ② Insert the pin (7) into the fixing hole to lock the pedal.
- ③ Using the tie rod (15), adjust the pedal height in the locked condition.
 - ★ Pedal height: 124 mm (4.9 in.)
- ④ With the pedal still locked, check that there is no looseness in the dashboard.
- ⑤ Depress the pedal (11) and check that the lock is smoothly released.
- ⑥ If the above checks (④ and ⑤) show no problem, tighten the locknuts (14) and (16) to fix the pedal.

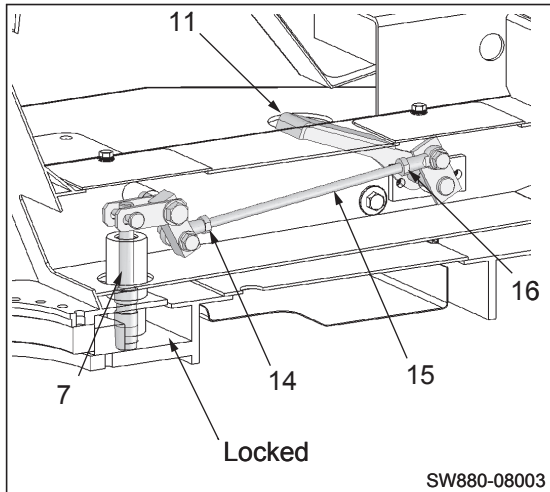

Pedal released

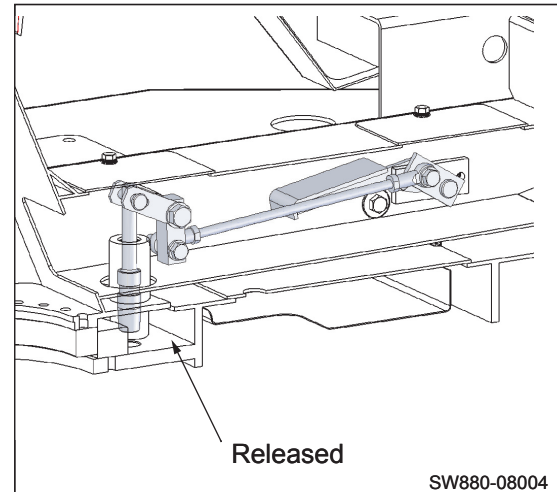

Pedal depressed

- The numbers in parentheses that appear in the above sentences and the numbers in the above illustrations are consistent with the lead line numbers shown in “1-2. Structure of Operator Station” (page 8-002).

WATER SPRAY SYSTEM

1. WATER SPRAY SYSTEM

1-1. Water Spray System

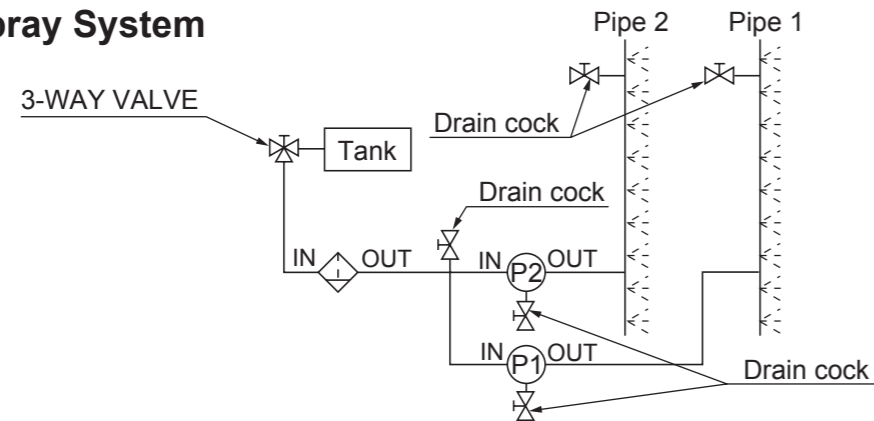

WATER SPRAY DIAGRAM

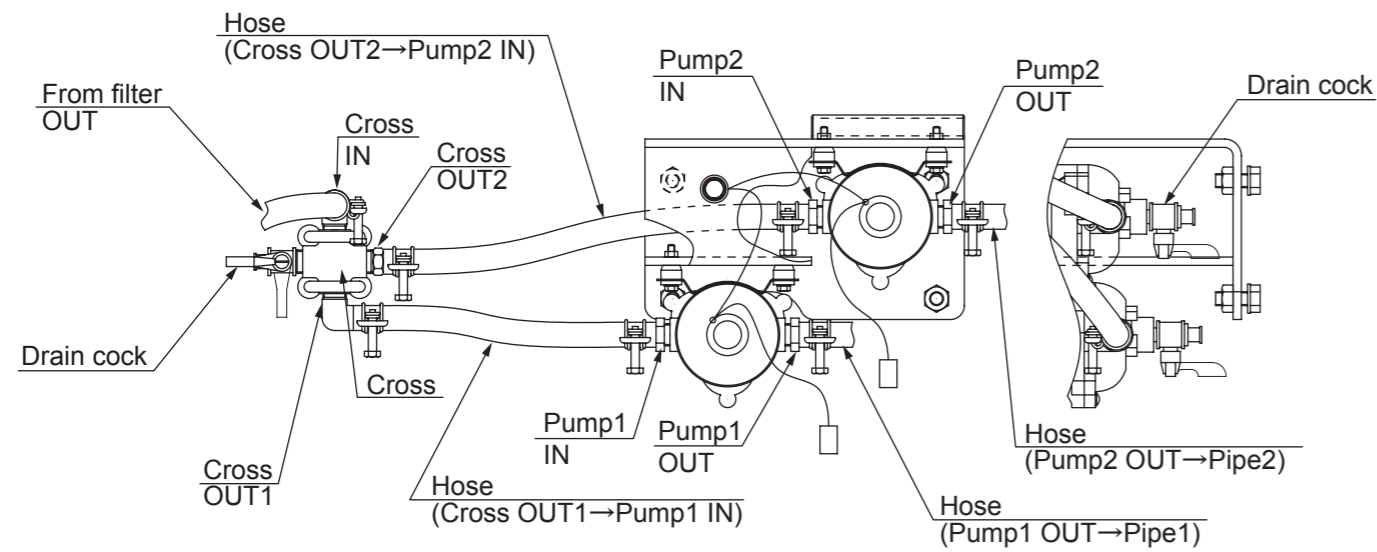

SECTION A-A

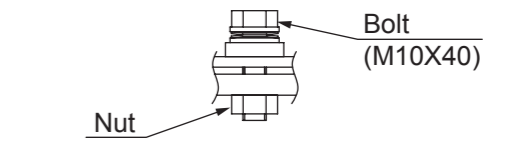
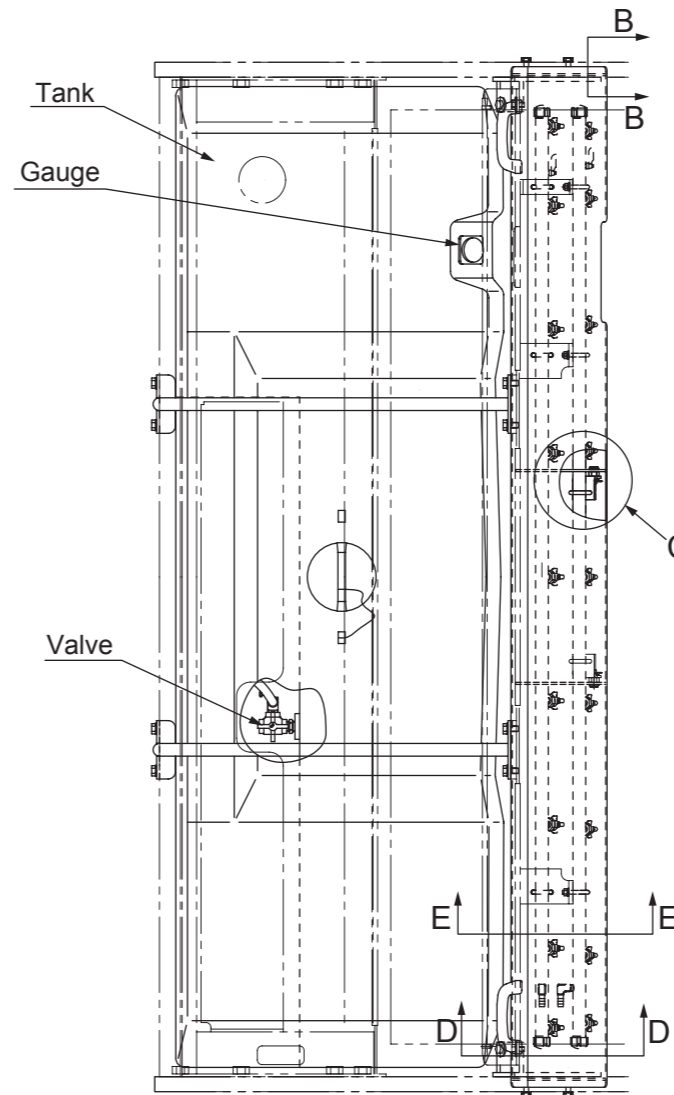

SECTION B-B

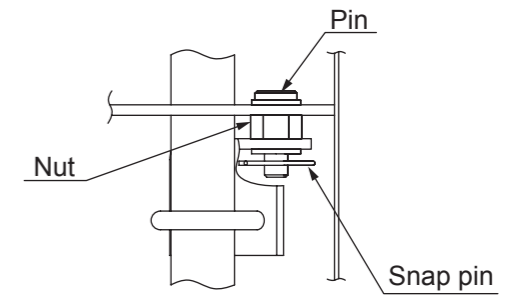

DETAIL C

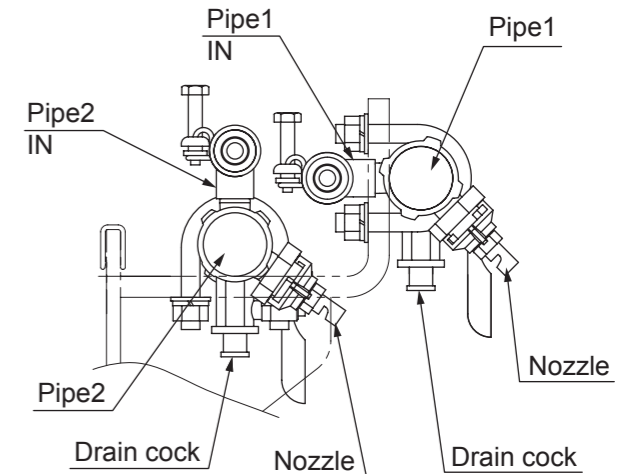

SECTION D-D

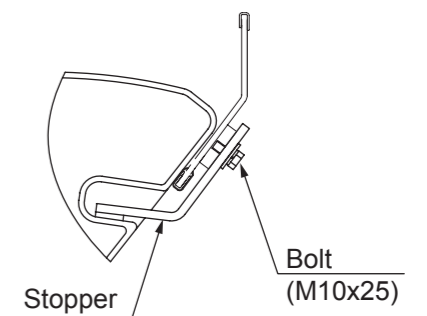
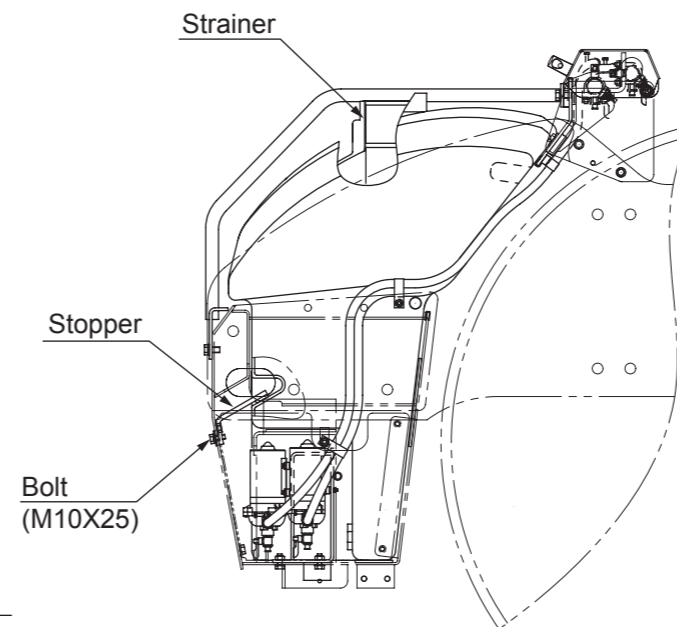
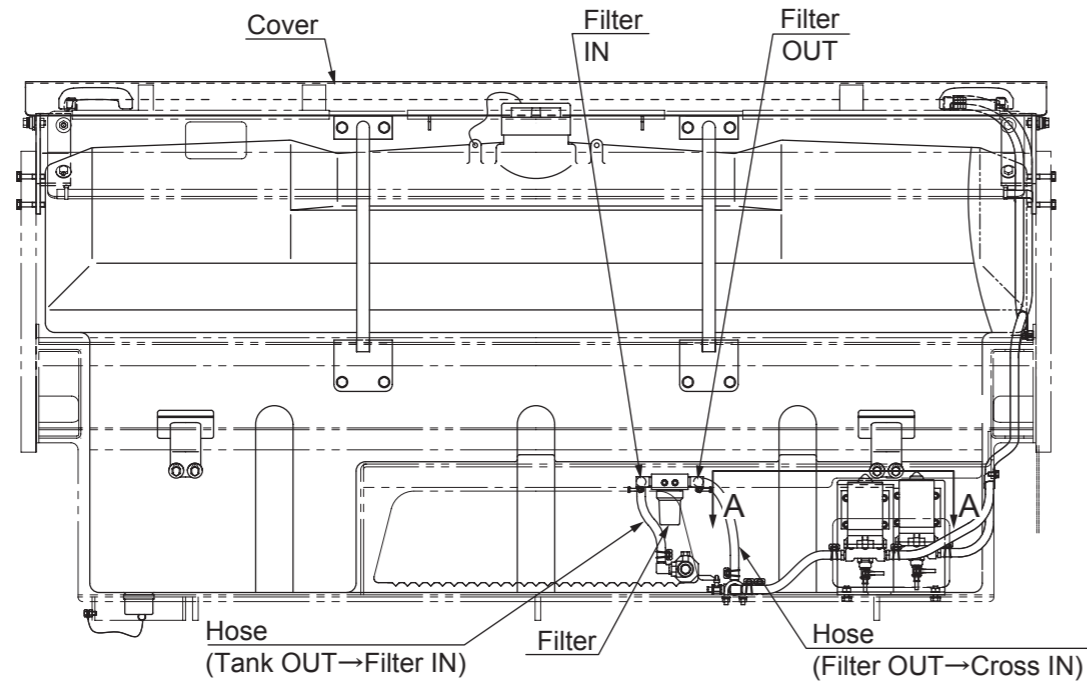

SECTION E-E

1-2. Water Spray Pump

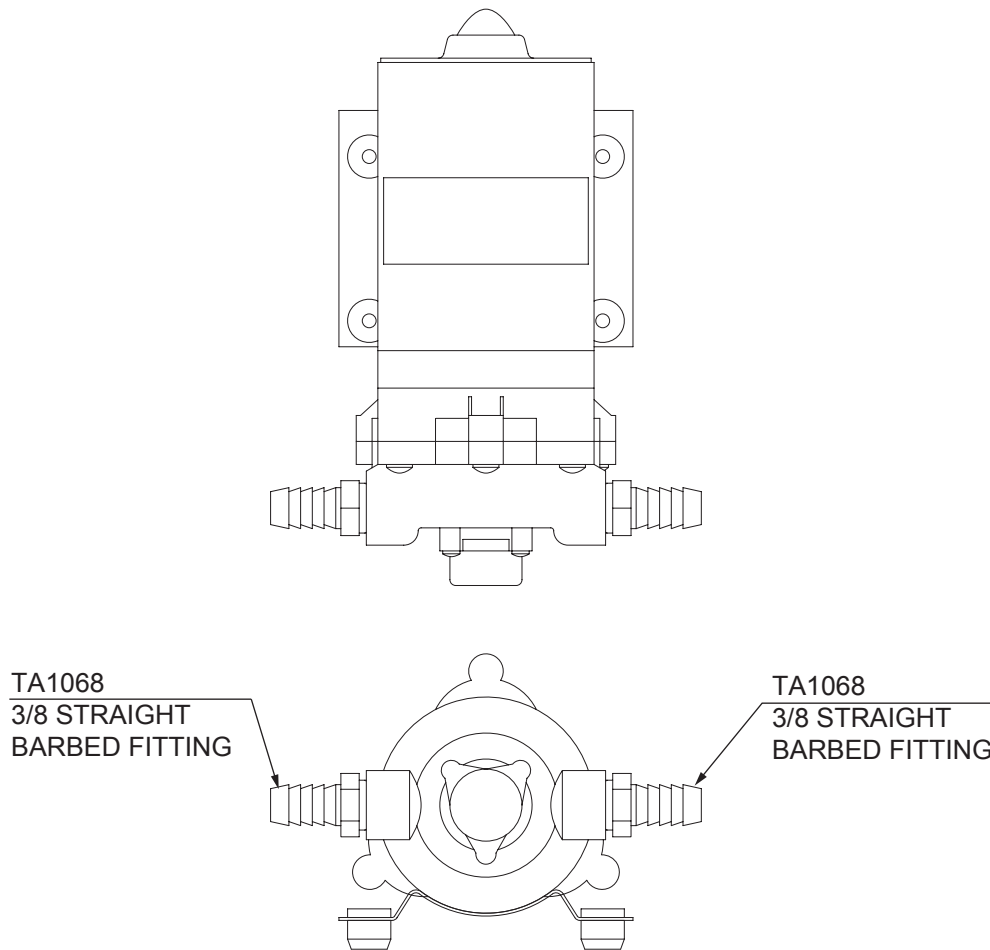

SW880-09001

Specifications

- Model : 8000-543-250
- Discharge rate : 4.5 L/min (1.2 gal./min)
- Discharge pressure : 0.17 MPa (24.7 psi)
- Weight : 1.8 kg (4.0 lbs.)

INSPECTION AND ADJUSTMENT

1. INSPECTION AND ADJUSTMENT

1-1. Inspection and Adjustment

1-1-1. Safety precautions for inspection and adjustment

⚠ WARNING

Unexpected vehicle movement may cause a serious accident. When inspecting the machine while the engine is running, always follow the instructions below.

- Park the machine on level, flat ground.
- Apply the parking brake.
- Set chocks in front and behind each drum or tire.
- Make sure that service personnel are given the appropriate information at the appropriate time.
- Make sure that no one can enter any hazardous area.

⚠ CAUTION

Do not work on the hydraulic system while the engine is running and the system is hot and under pressure. Do not disconnect hydraulic hoses or fittings until the system has cooled and pressure has been properly relieved.

Before removing any plugs from the pressure measurement ports, always release any residual pressure from the piping and open the cap of the fluid tank to release and pressure.

⚠ WARNING

Inadvertent starting the engine may cause a serious accident.

When inspecting the engine, make sure to exchange the appropriate cues and hand signal with the person at the operator station to avoid any accidents.

⚠ CAUTION

Before inspecting inside of the engine compartment, always stop the engine.

Contact with the fan, V-belt or exhaust system parts while the engine is running may cause serious injury.

1-1-2. Preparation for inspection and adjustment

- Prepare the necessary measuring instruments. In addition, particularly when measuring pressure values, make sure to prepare the appropriate hoses, adapters and a plug removal tool for the pressure reading port.
- Make sure that the instruments to be used operate normally.
When handling the instruments, exercise sufficient caution not to drop or apply any impact to them. Doing so may adversely affect the calibration. Another important point is to inspect the instruments regularly. An instrument that does not start from the appropriate zero point may give an inaccurate reading.

1-1-3. Precautions for inspection and adjustment

- When performing inspections and adjustments, pay special attention to safety.
- For each inspection, always take three measurements for each measurement point. If the measurements significantly differ, the measurement method may be incorrect. In such a case, take measurements once again and calculate their average.

1-1-4. Warm-up

- Machinery will not exhibit their true performance under the cold condition. Before taking measurements, always warm up the engine and make sure that the fluid and engine coolant are warmed to their specified normal operating temperatures.

2. MEASUREMENT AND ADJUSTMENT OF PROPULSION CIRCUIT PRESSURE

2-1. Measurement

⚠ WARNING

Confirm that the parking brake works properly before measurement.

- Oil temperature during measurement: $50 \pm 5^{\circ}\text{C}$
($122 \pm 41^{\circ}\text{F}$)
- ① Remove the plugs from the couplings (1) and (2) of the valve block gauge ports. Attach the pressure gauge through the hose (a) and the adapter (b).
 - Gauge port : 9/16-18UNF
 - Coupling : 9/16-18UNF×M16
 - Adapter for hose (a) : M16 P=2.0
 - Pressure gauge connector (b) : M16×G3/8
 - Forward-side gauge port : (1)
 - Reverse-side gauge port : (2)
 - Pressure gauge : 0 to 49 MPa
(0 to 7,105 psi)
- ② Set the speed mode switch to the “” position.
- ③ Set the vibration frequency selector switch to the “2,500 vpm” position.
- ④ Start the engine and set the engine speed switch to the “FULL” position.
- ⑤ Establish a condition in which the vehicle propulsion load becomes maximal.
(Pressure does not build up unless propulsion load is applied.)
- ⑥ With the propulsion load at maximum, slowly move the forward-reverse lever to the side to be measured. Then, read the pressure indicated by the pressure gauge.
- ⑦ After measuring, promptly return the forward-reverse lever to “neutral”.

- ★ **Maximum circuit pressure**
(pressure override valve setting)
: $37.3 \pm 1.0 \text{ MPa}$ ($5,409 \pm 145 \text{ psi}$)

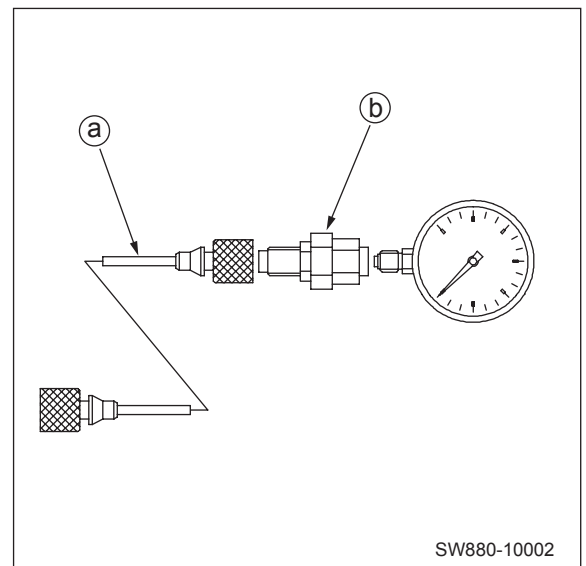
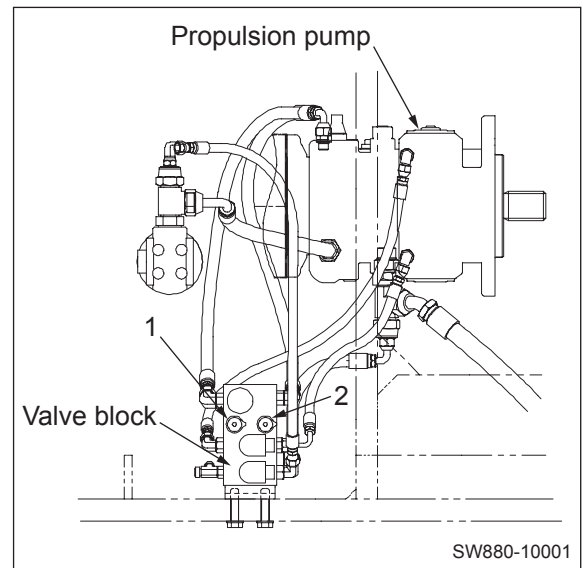

2-2. Adjustment

- If the measurement results indicate the pressure deviating from the maximum circuit pressure range, make an adjustment in accordance with the procedure described below.

2-2-1. If the pressures on both the forward and reverse sides deviate from the maximum circuit pressure range by the same value

- ① Check the locknut (3) of the pressure override valve (1-13) for evidence of having loosened.
- ② If there is evidence of the locknut having loosened, adjust the pressure override valve so that the pressure becomes within the maximum circuit pressure range while watching the pressure gauge.
 - To adjust the pressure, loosen the locknut (3) and turn the adjustment screw (4).

Adjustment screw turned clockwise

: Pressure rise

Adjustment screw turned counterclockwise

: Pressure drop

Pressure change rate : 9.8 MPa/turn
(1,421 psi/turn)

- ③ If there is no evidence of the locknut having loosened, remove the pressure override valve (1-13).
- ④ Check the removed pressure override valve for trapped dirt and scratches on its seat.
- ⑤ If trapped dirt is present, disassemble and clean the pressure override valve.
- ⑥ If a scratch is found on the seat, replace the pressure override valve.
- ⑦ After adjustment, measure the pressure again and check that the pressure reaches the maximum circuit pressure range.

 (1-13) Pressure override valve
: 22 N·m (16 lbf·ft)

(NOTICE)

- Carefully disassemble and reassemble after taking steps to prevent foreign material from getting in.

- The numbers such as “1-13” appearing in the above illustrations are consistent with the lead line numbers shown in the illustration of the propulsion pump in “2-3. Hydraulic Component Specifications” (page 4-006).

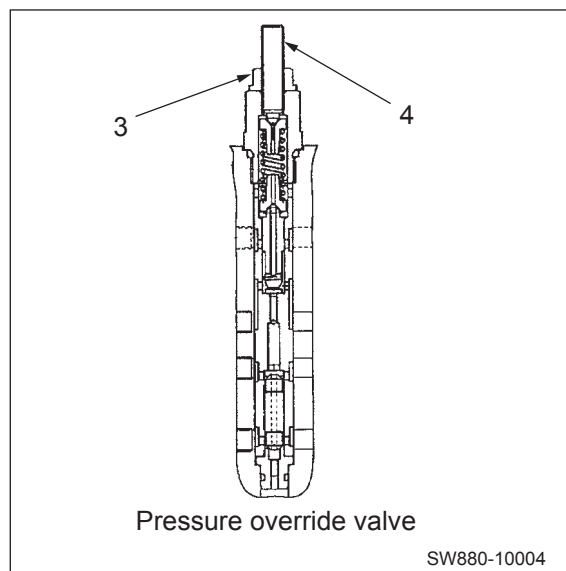
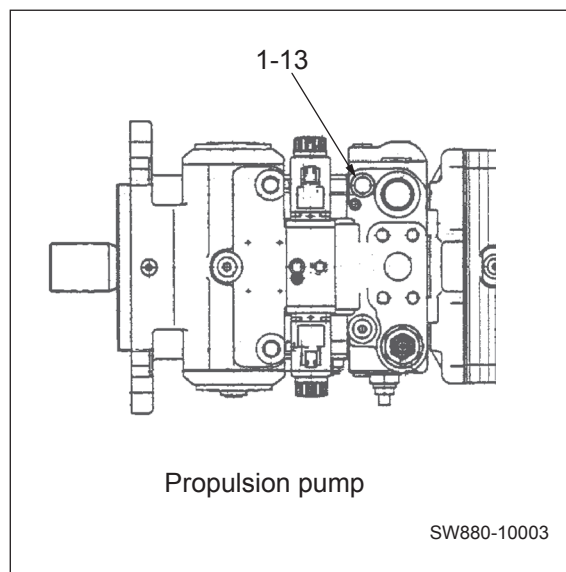

2-2-2. If the pressure on either the forward or reverse side deviates from the maximum circuit pressure range

- ① Check the locknut (5) of the high-pressure relief valve (1-11) or (1-12) for evidence of having loosened.
 - High-pressure relief valve (1-11): Reverse side
 - High-pressure relief valve (1-12): Forward side
- ② If there is evidence of the locknut having loosened, adjust the high-pressure relief valve so that the pressure becomes within the maximum circuit pressure range while watching the pressure gauge.
 - To adjust the pressure, loosen the locknut (5) and turn the adjustment screw (6).

Adjustment screw turned clockwise

: Pressure rise

Adjustment screw turned counterclockwise

: Pressure drop

Pressure change rate : 20 MPa/turn

(2,900 psi/turn)

- ③ If there is no evidence of the locknut having loosened, remove the high-pressure relief valve (1-11) or (1-12).
- ④ Check the removed high-pressure relief valve for trapped dirt and scratches on its seat.
- ⑤ If trapped dirt is present, disassemble and clean the high-pressure relief valve.
- ⑥ If a scratch is found on the seat, replace the high-pressure relief valve.
- ⑦ After adjustment, measure the pressure again and check that the pressure reaches the maximum circuit pressure range.

 (1-11) and (1-12) High-pressure relief valve
: 20 N·m (15 lbf·ft)

(NOTICE)

- **Carefully disassemble and reassemble after taking steps to prevent foreign material from getting in.**
- The numbers such as “1-11” and “1-12” appearing in the above illustrations are consistent with the lead line numbers shown in the illustration of the propulsion pump in “2-3. Hydraulic Component Specifications” (page 4-006).

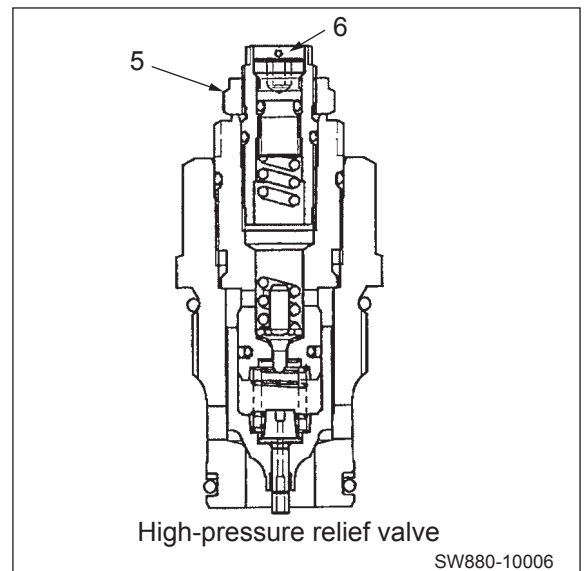
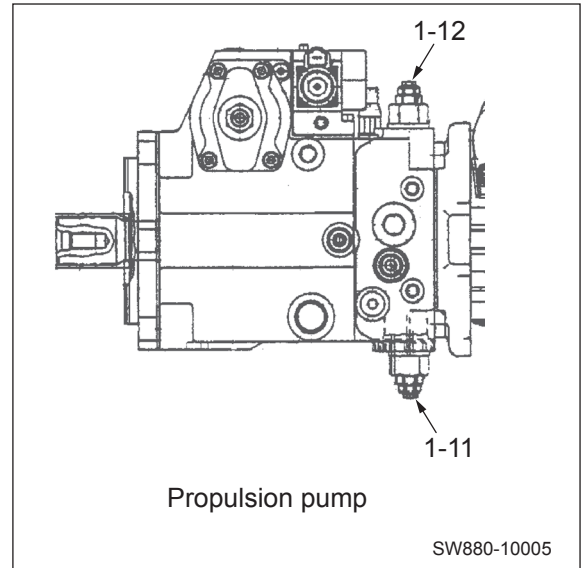

3. MEASUREMENT AND ADJUSTMENT OF PROPULSION CHARGE CIRCUIT PRESSURE

- Since the oil in the charge circuit is supplied from the steering circuit, confirm that the steering operation is normal before measurement.

3-1. Measurement

- Oil temperature during measurement: $50 \pm 5^{\circ}\text{C}$
($122 \pm 41^{\circ}\text{F}$)
- ① Remove the plug from the charge pressure gauge port (1-8). Attach the pressure gauge through the adapter (C).
 - Gauge port: 3/4-16UNF
 - Pressure gauge: 0 to 4.9 MPa (0 to 711 psi)
 - ② Press the parking brake switch to set the parking brake to "ON".
 - ③ Start the engine and set the engine speed switch to the "FULL" position. Then, read the pressure indicated by the pressure gauge.

- ★ **Standard charge relief pressure setting**
: $2.5 \pm 0.2 \text{ MPa}$ ($362 \pm 29 \text{ psi}$)

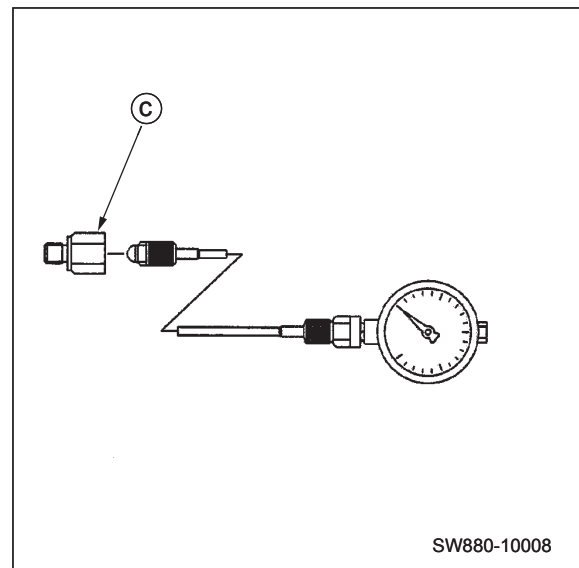
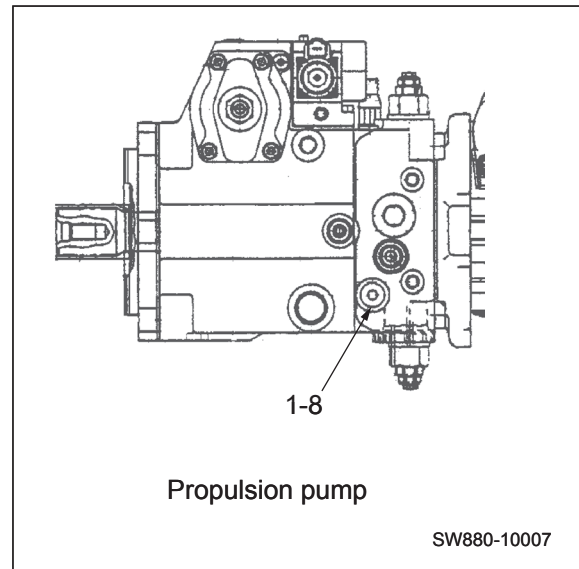

- The number "1-8" appearing in the above illustrations is consistent with the lead line numbers shown in the illustration of the propulsion pump in "2-3. Hydraulic Component Specifications" (page 4-006).

3-2. Adjustment

- If the measurement results indicate the pressure deviating from the standard charge relief pressure setting range, make an adjustment in accordance with the procedure described below.

- ① Check the locknut (1) of the charge relief valve (1-15) for evidence of having loosened.
 - ② If there is evidence of the locknut having loosened, adjust the charge relief valve so that the pressure becomes within the standard charge relief valve pressure setting range while watching the pressure gauge.
- To adjust the pressure, loosen the locknut (1) and turn the adjustment screw (2).

Adjustment screw turned clockwise

: Pressure rise

Adjustment screw turned counterclockwise

: Pressure drop

Pressure change rate : 0.36 MPa/turn
(52 psi/turn)

- ③ If there is no evidence of the locknut having loosened, remove the charge relief valve (1-15).
- ④ Check the removed charge relief valve for trapped dirt and scratches on its seat.
- ⑤ If trapped dirt is present, disassemble and clean the charge relief valve.
- ⑥ If a scratch is found on the seat, replace the charge relief valve.
- ⑦ After adjustment, measure the pressure again and check that the pressure reaches the standard charge relief valve pressure setting range.

 (1-15) Charge relief valve: 44 N·m (32 lbf·ft)

(NOTICE)

- **Carefully disassemble and reassemble after taking steps to prevent foreign material from getting in.**

- The number “1-15” appearing in the above illustrations is consistent with the lead line numbers shown in the illustration of the propulsion pump in “2-3. Hydraulic Component Specifications” (page 4-006).

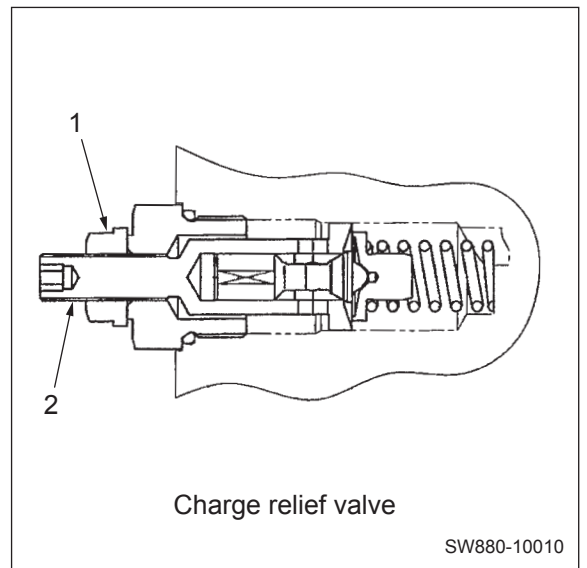
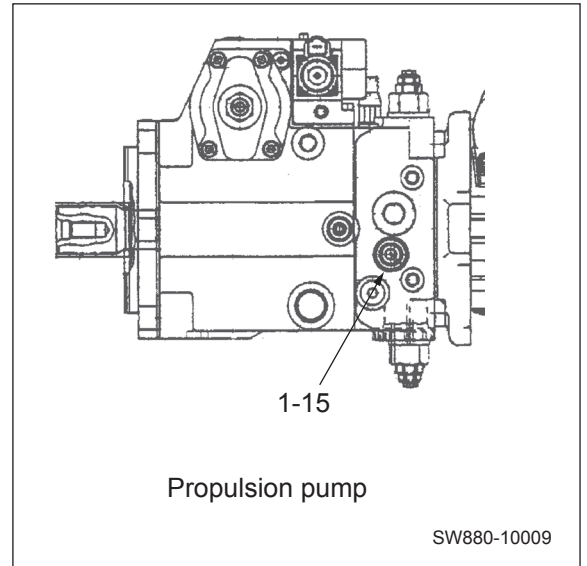

4. MEASUREMENT OF PROPULSION SERVO CIRCUIT PRESSURE

4-1. Measurement

- Oil temperature during measurement: $50 \pm 5^{\circ}\text{C}$
($122 \pm 41^{\circ}\text{F}$)
- ① Disconnect the hoses (2) and (3) from the neutral solenoid valve (1). Attach the pressure gauge through the adapter (d) .
 - Adapter (d) : 4-4LOHL6G5TP (Parker part number)
 - Pressure gauge: 0 to 4.9 MPa (0 to 711 psi)
- ② Press the parking brake switch to set the parking brake to "ON".
 - With the parking brake "ON", the pump's swash plate remains in the neutral state even if the forward-reverse lever is moved to either the forward or reverse side.
- ③ Start the engine and set the engine speed switch to the "FULL" position.
- ④ Operate the forward-reverse lever and then read the pressure indicated by the pressure gauge.
 - With the parking brake "ON", the measured pressures of (2) and (3) are the same.
 - With the parking brake "OFF", the measured pressures of (2) and (3) are different.

★ **Standard charge relief setting pressure**
: $2.5 \pm 0.2 \text{ MPa}$ ($362 \pm 29 \text{ psi}$)

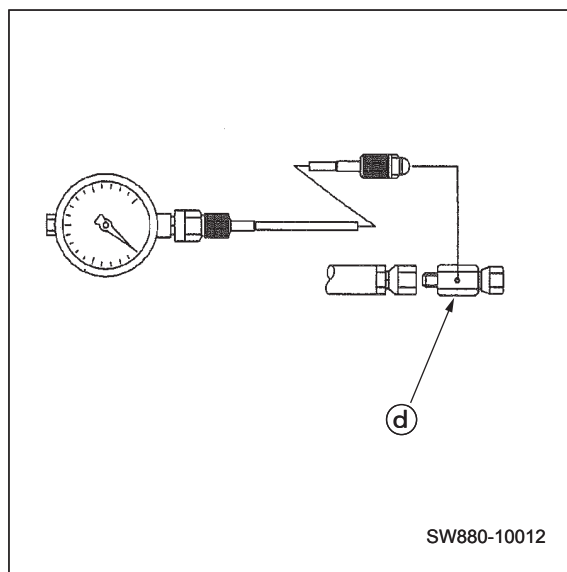
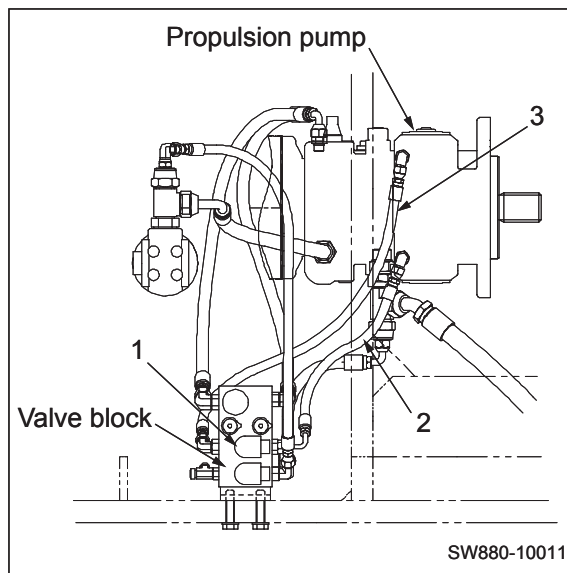

5. MEASUREMENT OF PARKING BRAKE RELEASE PRESSURE

5-1. Measurement

- Oil temperature during measurement: $50 \pm 5^{\circ}\text{C}$
($122 \pm 41^{\circ}\text{F}$)
- ① Disconnect the hose (1) or (2) from the brake solenoid valve. Attach the pressure gauge through the adapter (d).
- Adapter (d) : 4-4LOHL6G5TP (Parker part number)
- Pressure gauge: 0 to 4.9 MPa (0 to 711 psi)
- ② Confirm that the forward-reverse level is in the neutral position.
- ③ Press the parking brake switch to set the parking brake to "ON".
- ④ Start the engine and set the engine speed switch to the "FULL" position.
- ⑤ Set the parking brake switch to "OFF" and read the brake release pressure indicated by the pressure gauge.

★ **Standard charge relief pressure setting
(brake release pressure)**

: $2.5 \pm 0.2 \text{ MPa}$ ($362 \pm 29 \text{ psi}$)

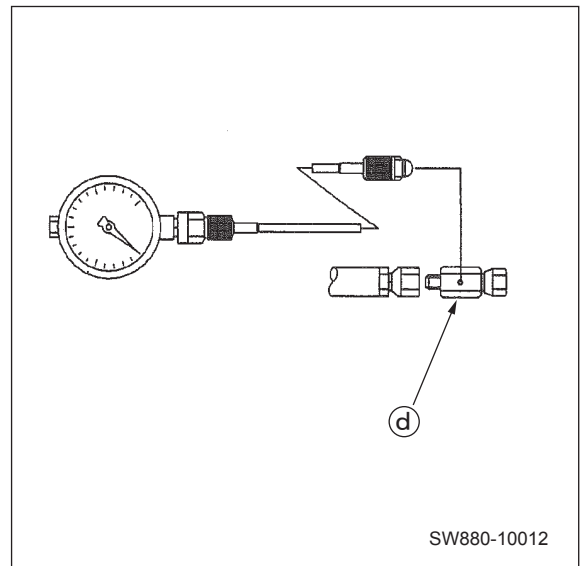
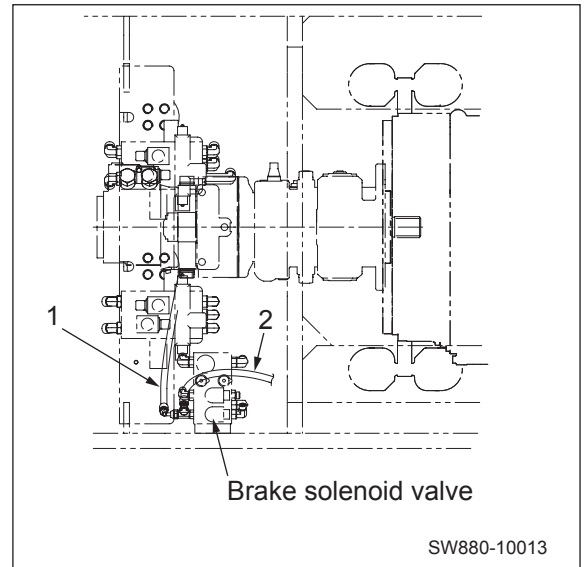

6. MEASUREMENT AND INSPECTION OF VIBRATOR CIRCUIT PRESSURE

6-1. Measurement

- Oil temperature during measurement: $50 \pm 5^{\circ}\text{C}$
($122 \pm 41^{\circ}\text{F}$)

① Disconnect the plug from the coupling (1), (2), (3) or (4) of the gauge port to be measured on the valve blocks installed in the vibrator circuit. Attach the pressure gauge through the hose (a) and the adapter (b).

- Gauge port : 9/16-18UNF
- Coupling : 9/16-18UNF×M16
- Adapter for hose (a) : M16 P=2.0
- Pressure gauge connector (b) : M16×G3/8
- Front drum low-amplitude side gauge port : (1)
- Front drum high-amplitude side gauge port : (2)
- Rear drum low-amplitude side gauge port : (3)
- Rear drum high-amplitude side gauge port : (4)
- Pressure gauge : 0 to 49 MPa (0 to 7,105 psi)

- ② Press the parking brake switch to set the parking brake to "ON".
- ③ Set the vibration mode (continuous/automatic) selector switch to the "Continuous" position.
- ④ Start the engine and set the engine speed switch to the "FULL" position.
- ⑤ Press the vibration forward-reverse lever switch to turn the vibrator drum "ON". Then, read the pressure gauge for the maximum value of the vibrator circuit pressure.

(NOTICE)

- Take care not to operate the vibratory drum for a longer period of time than necessary with the vehicle stationary. Otherwise, the vibrator bearing could be seized.

- ⑥ Turn the vibrator drum "OFF" as soon as the measurement is finished.

★ Maximum circuit pressure value

(effective differential pressure value)

: $31.5 \pm 1.0 \text{ MPa}$ ($4,567 \pm 145 \text{ psi}$)

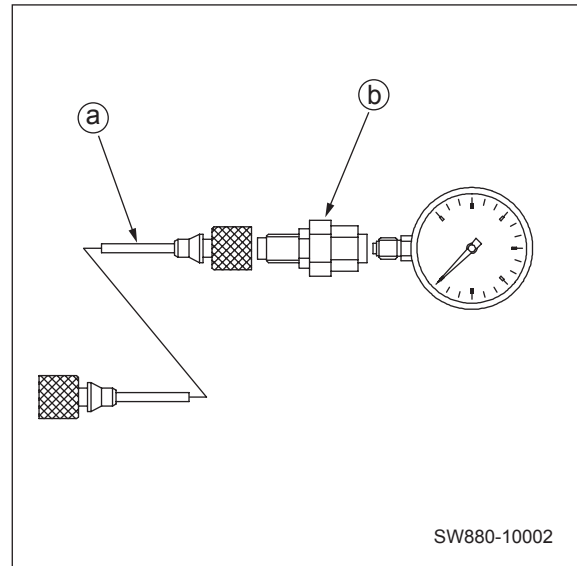
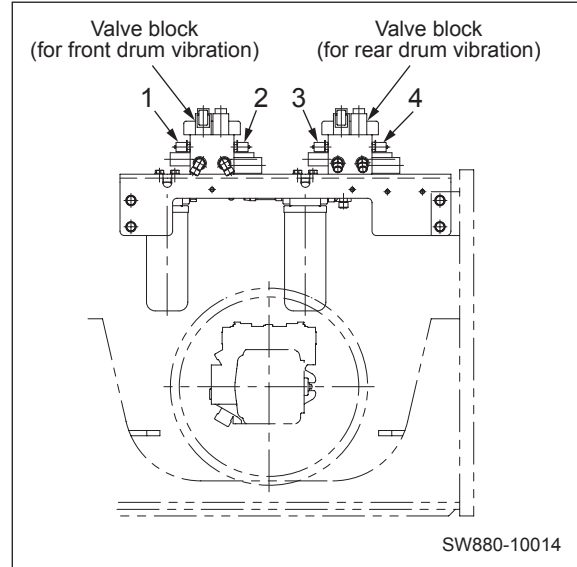

6-2. Inspection

- If the measurement results indicate the pressure deviating from the maximum circuit pressure range, make an adjustment in accordance with the procedure described below.

6-2-1. Inspection of the high-pressure relief valves installed in the vibrator pump

- ① Remove the high-pressure relief valve (2-15), (2-16), (2-17) or (2-18) responsible for the vibrator whose circuit pressure is abnormal.

- High-pressure relief valve (2-15)
: Front drum low-amplitude side
- High-pressure relief valve (2-16)
: Rear drum low-amplitude side
- High-pressure relief valve (2-17)
: Front drum high-amplitude side
- High-pressure relief valve (2-18)
: Rear drum high-amplitude side

- ② If the setting of the adjustment screw (5) of the removed high-pressure relief valve is incorrect, adjust it so that the pressure becomes within the maximum circuit pressure range.

- To adjust the pressure, turn the adjustment screw.

Adjustment screw turned clockwise

: Pressure rise

Adjustment screw turned counterclockwise

: Pressure drop

Pressure change rate : 4.3 MPa/turn

(623 psi/turn)

- ③ If the setting of the adjustment screw is correct, check it for trapped dirt. If trapped dirt is present, disassemble and clean the high-pressure relief valve.
- ④ If the pressure still deviates from the maximum circuit pressure range after the valve is disassembled and cleaned, replace the high-pressure relief valve.
- ⑤ After inspection, measure the pressure again and check that the pressure reaches the maximum circuit pressure range.

 (2-15) to (2-18) High-pressure relief valve
: 160 N·m (118 lbf·ft)

(NOTICE)

- **Carefully disassemble and reassemble after taking steps to prevent foreign material from getting in.**

- The numbers “2-15,” “2-16,” “2-17” and “2-18” appearing in the above illustrations are consistent with the lead line numbers shown in the illustration of the propulsion pump in “2-3. Hydraulic Component Specifications” (page 4-006).

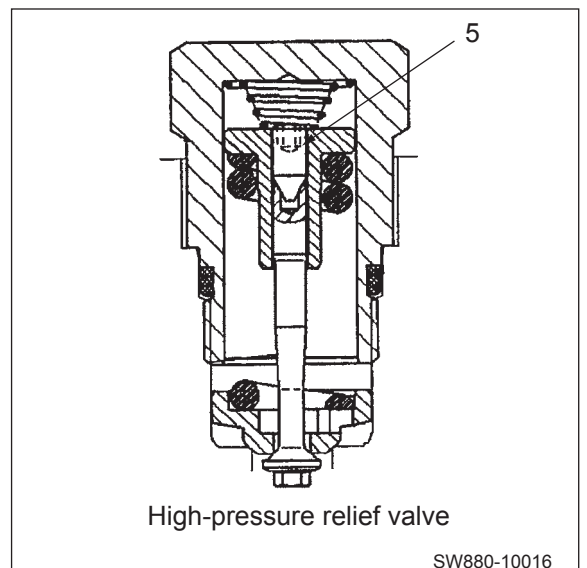
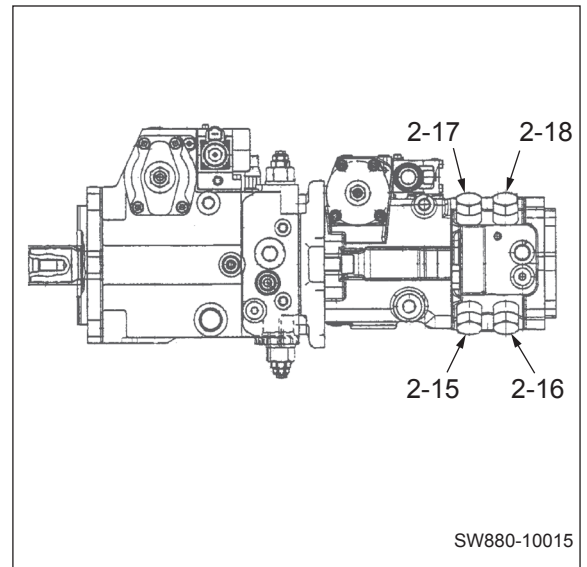

6-2-2. Inspection of the high-pressure relief valves (port relief valves) installed in the valve blocks in the vibrator circuit

- ① Check the locknut (10) of the high-pressure relief valves (6), (7), (8) or (9) for evidence of having loosened.
 - High-pressure relief valve (2-15)
: Front drum low-amplitude side
 - High-pressure relief valve (2-16)
: Front drum high-amplitude side
 - High-pressure relief valve (2-17)
: Rear drum low-amplitude side
 - High-pressure relief valve (2-18)
: Rear drum high-amplitude side
- ② If there is evidence of the locknut having loosened, adjust the high-pressure relief valve so that the pressure becomes within the maximum circuit pressure range while watching the pressure gauge.
 - Before adjusting the pressure, energize the solenoid valve installed in the valve block to have it function as a port relief valve.
 - To adjust the pressure, loosen the locknut (10) and turn the adjustment screw (11).
 - Adjustment screw turned clockwise
: Pressure rise
 - Adjustment screw turned counterclockwise
: Pressure drop
 - Pressure change rate : 14 MPa/turn
(2,030 psi/turn)
- ③ If there is no evidence of the locknut having loosened, remove the high-pressure relief valve (6), (7), (8) or (9) and check the valves for trapped dirt and scratches on the seat.
- ④ If trapped dirt is present, disassemble and clean the high-pressure relief valve.
- ⑤ If a scratch is found on the seat, replace the high-pressure relief valve.
- ⑥ After adjustment, measure the pressure again and check that the pressure reaches the maximum circuit pressure range.

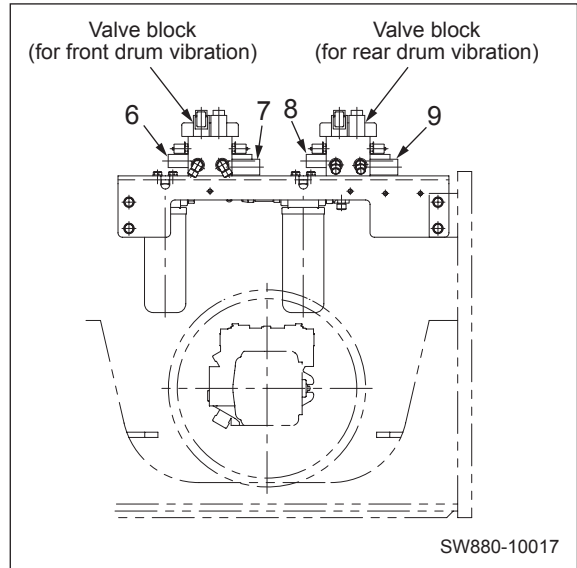

SW880-10017

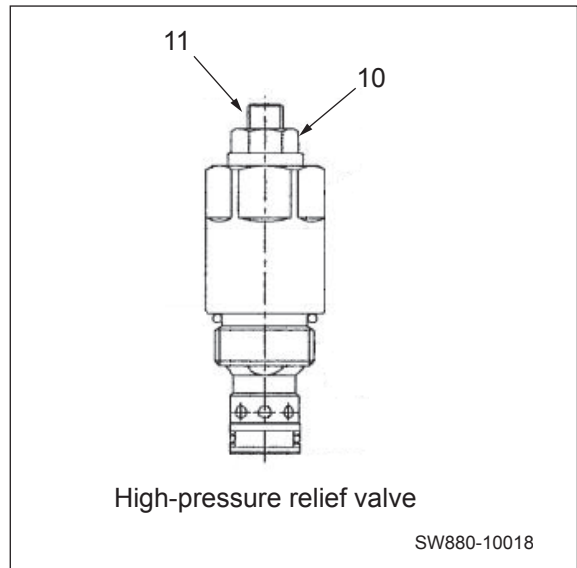

High-pressure relief valve

SW880-10018

 (6) to (9) High-pressure relief valve
: 13.5 N·m (10 lbf·ft)

(NOTICE)

- Carefully disassemble and reassemble after taking steps to prevent foreign material from getting in.

7. MEASUREMENT AND INSPECTION OF VIBRATION CHARGE CIRCUIT PRESSURE

7-1. Measurement

- Oil temperature during measurement: $50 \pm 5^{\circ}\text{C}$
($122 \pm 41^{\circ}\text{F}$)
- ① Remove the plug from the charge pressure gauge port (2-19). Attach the pressure gauge through the adapter ②.
 - Gauge port: 9/16-18UNF
 - Pressure gauge: 0 to 4.9 MPa (0 to 711 psi)
- ② Press the parking brake switch to set the parking brake to "ON".
- ③ Start the engine and set the engine speed switch to the "FULL" position.

★ **Standard charge relief setting pressure**
: $2.5 \pm 0.2 \text{ MPa}$ ($362 \pm 29 \text{ psi}$)

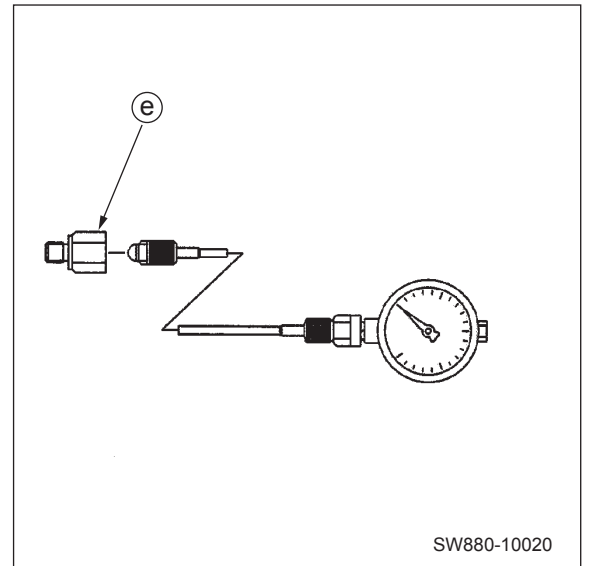
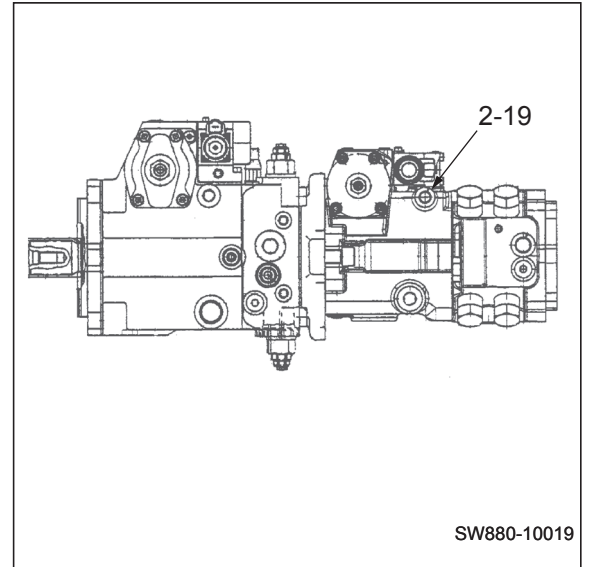

- The number (2-19) shown in the illustration above corresponds with the reference number for the part shown in the vibration pump drawing in 2-3. Hydraulic Equipment Specification (Page 4-006).

7-2. Inspection

- If the measurement results indicate the pressure deviating from the standard charge relief pressure setting range, make an adjustment in accordance with the procedure described below.
- Since the vibration charge relief valve is a fixed type, adjustment of the pressure setting is not possible.

- ① Remove the vibration charge relief valve (2-20).
- ② Check the removed vibration charge relief valve for trapped dirt and other abnormalities.
- ③ If trapped dirt is present, disassemble and clean the high-pressure relief valve.
- ④ If the pressure still deviates from the standard charge pressure setting range after the valve is disassembled and cleaned, replace the vibration charge relief valve.
- ⑤ After inspection, measure the pressure again and check that the pressure reaches the standard charge relief pressure setting range.

 (2-20) Vibration charge relief valve
 : 90 N·m (66 lbf·ft)

(NOTICE)

- **Carefully disassemble and reassemble after taking steps to prevent foreign material from getting in.**

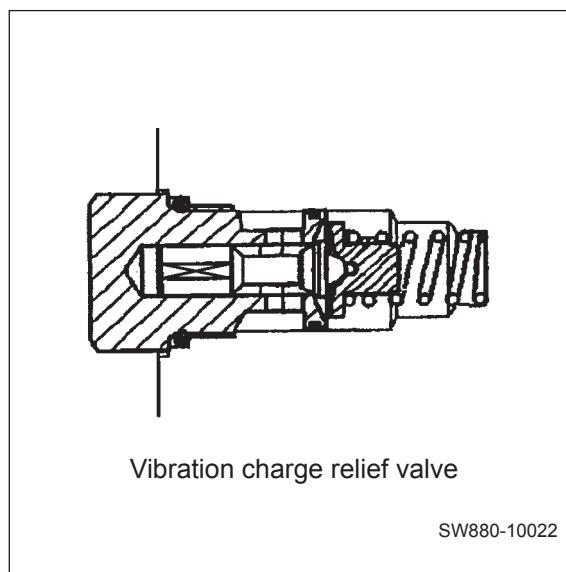
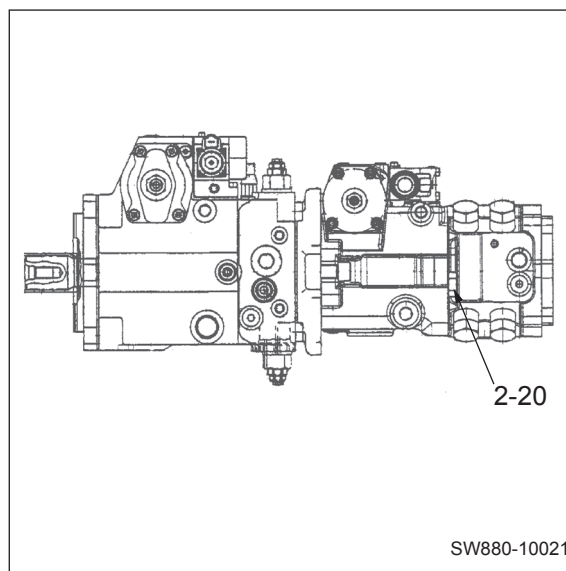

- The number “2-20” appearing in the above illustrations are consistent with the lead line numbers shown in the illustration of the propulsion pump in “2-3. Hydraulic Component Specifications” (page 4-006).

8. MEASUREMENT AND INSPECTION OF STEERING CIRCUIT PRESSURE

8-1. Measurement

⚠ WARNING

Make sure that there is no person around the articulated portion of the vehicle before operating the steering wheel.

- Oil temperature during measurement: $50 \pm 5^{\circ}\text{C}$
($122 \pm 41^{\circ}\text{F}$)
- ① Remove the hose (1) on the outlet side of the steering pump. Attach the pressure gauge through the adapter (f).
- Adapter (f) : 12-4LOHL6GT5TP (Parker part number)
- Pressure gauge: 0 to 24.5 MPa (0 to 3,553 psi)
- ② Confirm that the forward-reverse lever is in the neutral position properly.
- ③ Start the engine and set the engine speed switch to the "FULL" position. Turn the steering wheel to operate the relief valve and read the pressure indicated by the pressure gauge.

★ **Standard maximum circuit pressure**
: $17.5 \pm 1.0 \text{ MPa}$ ($2,538 \pm 145 \text{ psi}$)

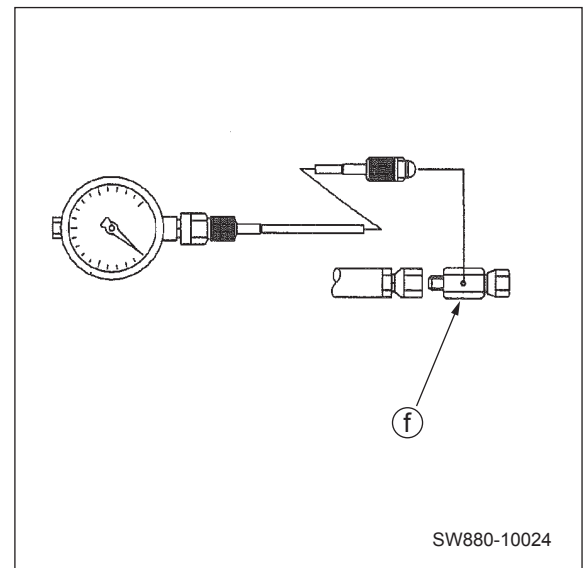
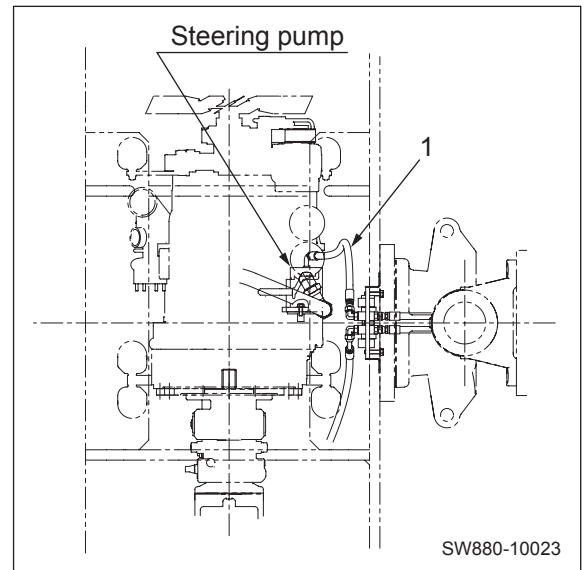

8-2. Inspection

- If the measurement results indicate the pressure deviating from the standard maximum circuit pressure range, make an adjustment in accordance with the procedure described below.

- ① Remove the relief valve (2) from the orbitrol.
- ② Check the removed relief valve for trapped dirt, scratches on its seat and other abnormalities.
- ③ If trapped dirt is present, disassemble and clean the relief valve.
- ④ If a scratch or any other abnormality is found on the seat, replace the relief valve.
- ⑤ After inspection, measure the pressure again and check that the pressure reaches the standard maximum circuit pressure range.

(NOTICE)

- **Carefully disassemble and reassemble after taking steps to prevent foreign material from getting in.**

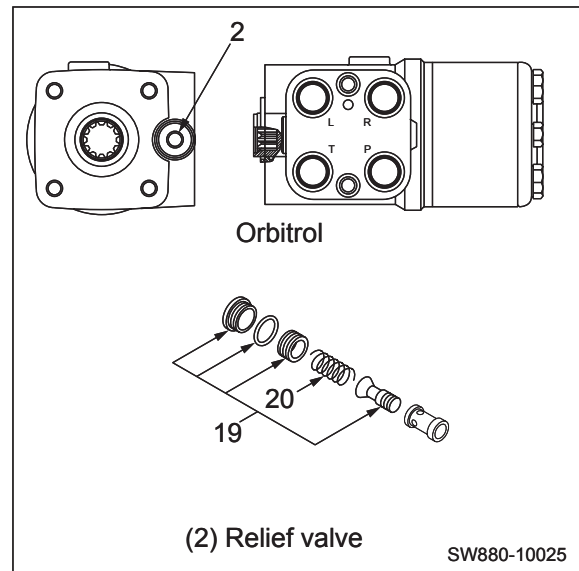

TROUBLESHOOTING

1. TROUBLESHOOTING

1-1. Safety Precautions for Troubleshooting

WARNING

Unexpected vehicle movement may cause a serious accident. When inspecting the machine while the engine is running, always follow the instructions below.

- Park the machine on level, flat ground.
- Apply the parking brake.
- Set chocks in front and behind each drum or tire.
- Make sure that service personnel are given the appropriate information at the appropriate time.
- Make sure that no one can enter any hazardous area.

CAUTION

Do not work on the hydraulic system while the engine is running and the system is hot and under pressure. Do not disconnect hydraulic hoses or fittings until the system has cooled and pressure has been properly relieved.

Before removing any plugs from the pressure measurement ports, always release any residual pressure from the piping and open the cap of the fluid tank to release and pressure.

WARNING

Inadvertent starting the engine may cause a serious accident.

When inspecting the engine, make sure to exchange the appropriate cues and hand signal with the person at the operator station to avoid any accidents.

CAUTION

Before inspecting inside of the engine compartment, always stop the engine.

Contact with the fan, V-belt or exhaust system parts while the engine is running may cause serious injury.

1-2. Important Information for Troubleshooting

Before conducting troubleshooting, it is important to carefully read the operation manual and workshop manual and understand the electric circuits for each component as well as the structure and function of each system. Sufficient knowledge of the systems will enable you to identify a possible cause much faster.

A fault or problem may seem to be related to many different factors. To identify the true cause, some experience is needed.

To perform the appropriate troubleshooting, it is important to learn not only the normal operations of the systems but also the possible symptoms that may occur when an abnormal condition is present. This chapter explains the possible causes and remedies for likely incidents taken from past experience.

1-3. Before Starting

The information in this section is provided to assist the troubleshooter in understanding the systems and quickly determine the causes when operating abnormalities occur.

The following steps are recommended:

1. If not familiar with the machine, study the Operator’s Manual and this Shop Manual.
2. Check with the operator for full details of the trouble, ask questions.
3. Verify the trouble by warming up the machine and operating it. Check the problem yourself.
4. Identify the problem with either a mechanical, hydraulic or electrical system source.
5. Isolate the problem to a particular component or circuit.
6. Eliminate the simplest or easiest to check possibilities first to prevent unnecessary disassembly of components.
7. Following repair or replacement of any parts, perform operational tests to verify that the problem has been eliminated and the performance of all the systems is normal.

1-4. Wire Color Code and Number

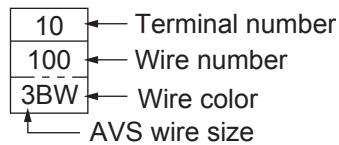

- The arrangement of connector terminals shown above is that of connecting surfaces on the connector side.

B	Black	BrY	Brown/ Yellow stripe	L	Blue	LgY	Light green/ Yellow stripe	W	White	YL	Yellow/ Blue stripe
BR	Black/ Red stripe	G	Green	LR	Blue/ Red stripe	R	Red	WB	White/ Black stripe	YR	Yellow/ Red stripe
BW	Black/ White stripe	GB	Green/ Black stripe	LW	Blue/ White stripe	RB	Red/ Black stripe	WL	White/ Blue stripe	YW	Yellow/ White stripe
BY	Black/ Yellow stripe	GL	Green/ Blue stripe	LY	Blue/ Yellow stripe	RG	Red/ Green stripe	WR	White/ Red stripe	Gy	Gray
Br	Brown	GR	Green/ Red stripe	Lg	Light green	RL	Red/ Blue stripe	WY	White/ Yellow stripe	O	Orange
BrB	Brown/ Black stripe	GW	Green/ White stripe	LgB	Light green/ Black stripe	RW	Red/ White stripe	Y	Yellow	Sb	Sky blue
BrR	Brown/ Red stripe	GY	Green/ Yellow stripe	LgR	Light green/ Red stripe	RY	Red/ Yellow stripe	YB	Yellow/ Black stripe	P	Pink
BrW	Brown/ White stripe			LgW	Light green/ White stripe			YG	Yellow/ Green stripe	Pu	Purple

2. ELECTRICAL SYSTEM TROUBLESHOOTING

2-1. When Performing Electrical System Fault Diagnosis

2-1-1. Safety rules and precautions to take during electric circuit fault diagnosis

⚠ WARNING

- Be very careful because the equipment can return to normal during an inspection and suddenly operate properly when a failure occurs due to a faulty contact or other such cause.
- Batteries can explode! All lead acid batteries generate hydrogen gas which is highly flammable. If ignited by a spark or flame, the gas may explode violently causing spraying of acid and fragmentation of the battery and possible severe personal injuries. Wear safety glasses when working near batteries. In case of contact with acid, flush immediately with water.
- Never disconnect any battery cable or charging circuit cable while the engine is running. If connection between the battery and the charging unit is broken, the charging unit will be damaged.
- When disconnecting or connecting a connector, be sure to turn the power supply OFF. (Electronic control parts such as the engine control unit, in particular, could be damaged internally.)
- Always disconnect the ground side of the battery first.
- Since connectors are not numbered, be sure to affix alignment marks so that you can restore them to their original condition.
- Before making a diagnosis, check related connectors for faulty connections. (Check by disconnecting and reconnecting related connectors several times.)
- Before proceeding to the next step, be sure to return the disconnected connectors to their original condition.
- When diagnosing a circuit (measuring the voltage, resistance, continuity and current), move related wiring and connectors several times, and check whether the tester's numerical values change. (If values change, faulty contact in the circuit is possible.)
- When measuring a waterproof connector, use an intermediate connector to prevent contact failure and corrosion. If there is no intermediate connector, use a pointed lead or a wire or sticking a needle into a relevant wire as illustrated below.
- Do not ground the circuit of the control unit or apply voltage to it unless otherwise specified.

<Measurement from the backside of connector>

<Measurement using a lead>

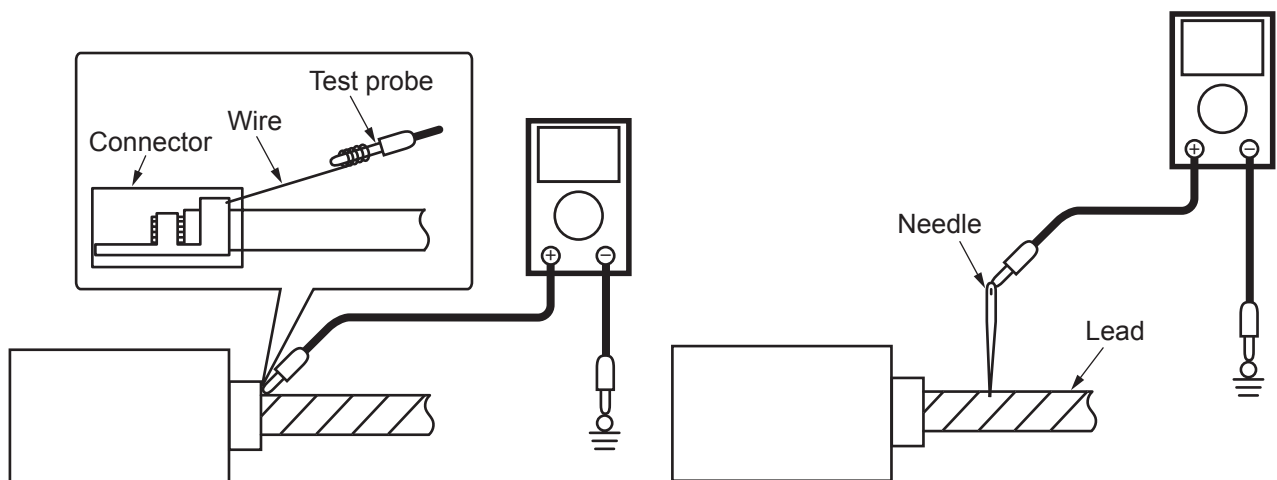

SW880-11001

2-1-2. Inspection procedures using a tester

Some of the various inspection procedures are presented here for reference, using a sample circuit below.

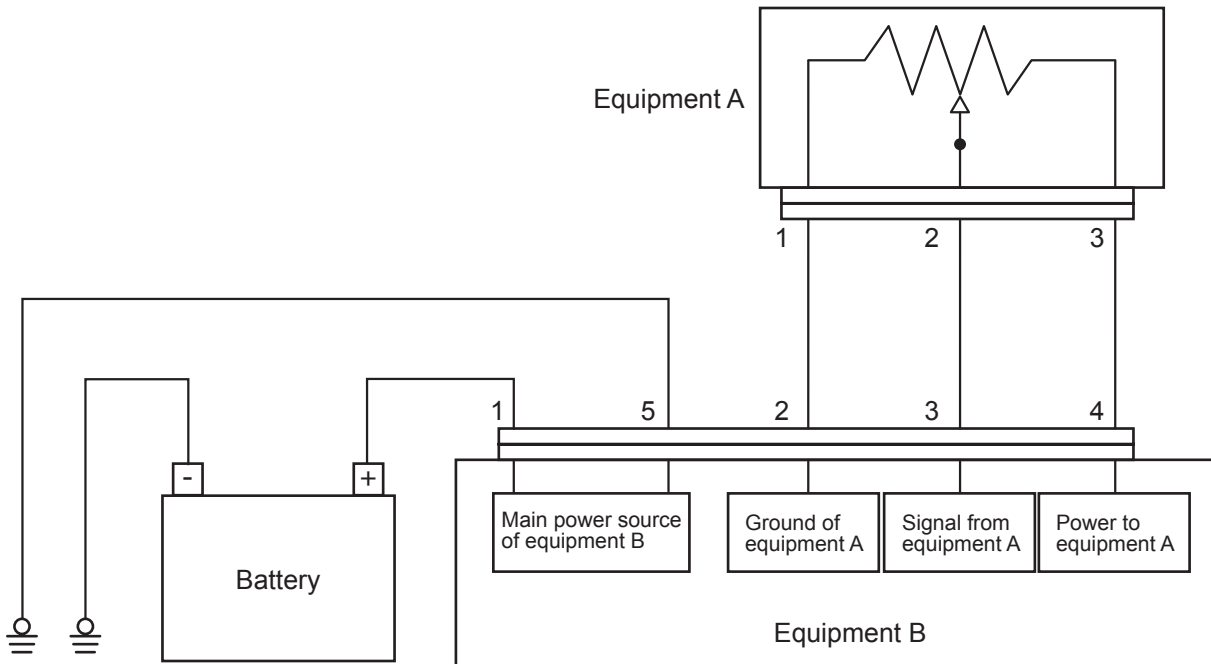

SW880-11002

1) Measuring resistance using tester

1-1) Measuring resistance of equipment A (measuring resistance between terminals 1 and 3)

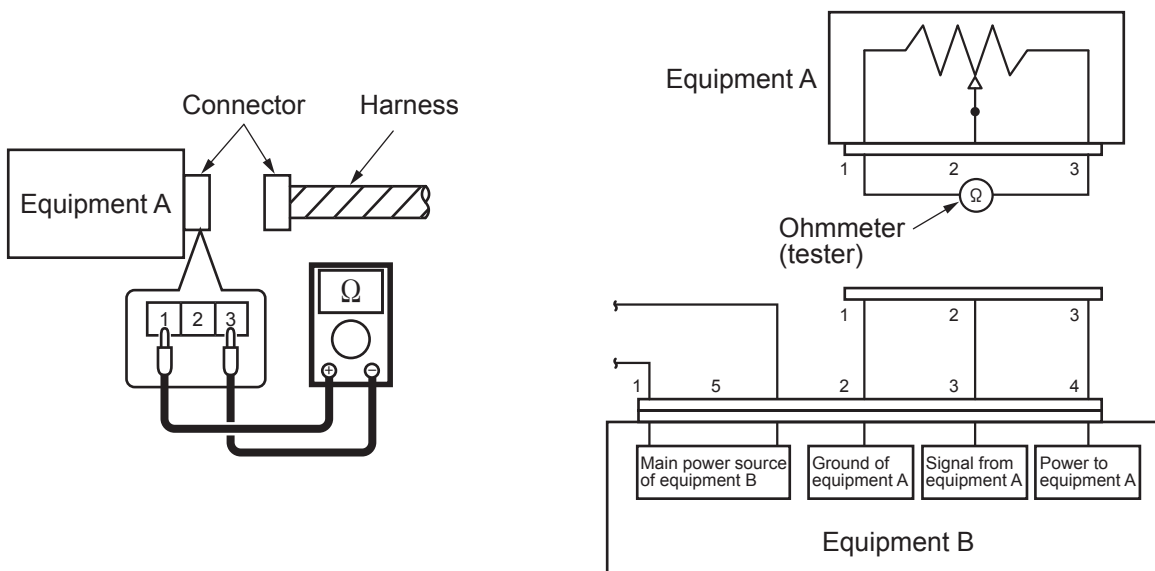

SW880-11003

Inspection procedure

- ① Disconnect the connector of equipment A.
- ② Connect the test probe (+) to connector terminal 1 of equipment A and the test probe (-) to connector terminal 3 of equipment A and measure the resistance. At this time, reversing the connector terminals between the probes (+) and (-) does not make any difference in the measurement.

1-2) Measuring resistance of harness (measuring resistance between terminal 1 of equipment A and terminal 2 of equipment B)

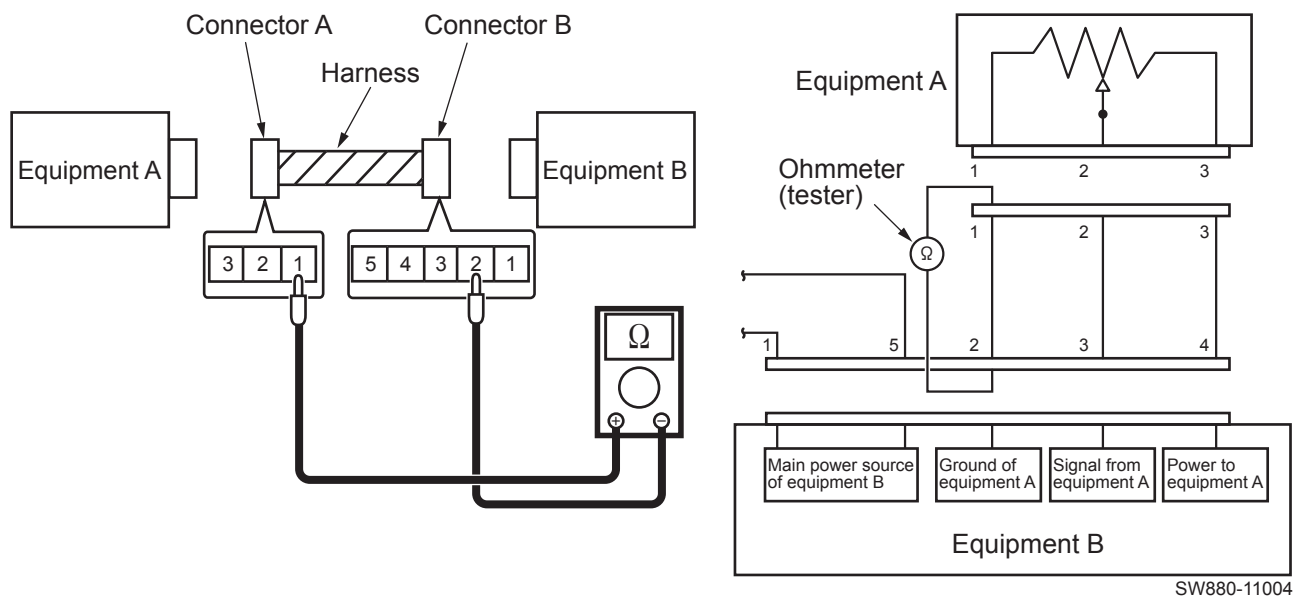

Inspection procedure

- ① Disconnect the connectors of equipment A and equipment B.
- ② Connect the test probe (+) to connector terminal 1 of equipment A and the test probe (-) to connector terminal 2 of equipment B and measure the resistance. At this time, reversing the connector terminals between the probes (+) and (-) does not make any difference in the measurement.

1-3) Measuring resistance of grounding wire (measuring resistance between terminal 5 of equipment B and ground)

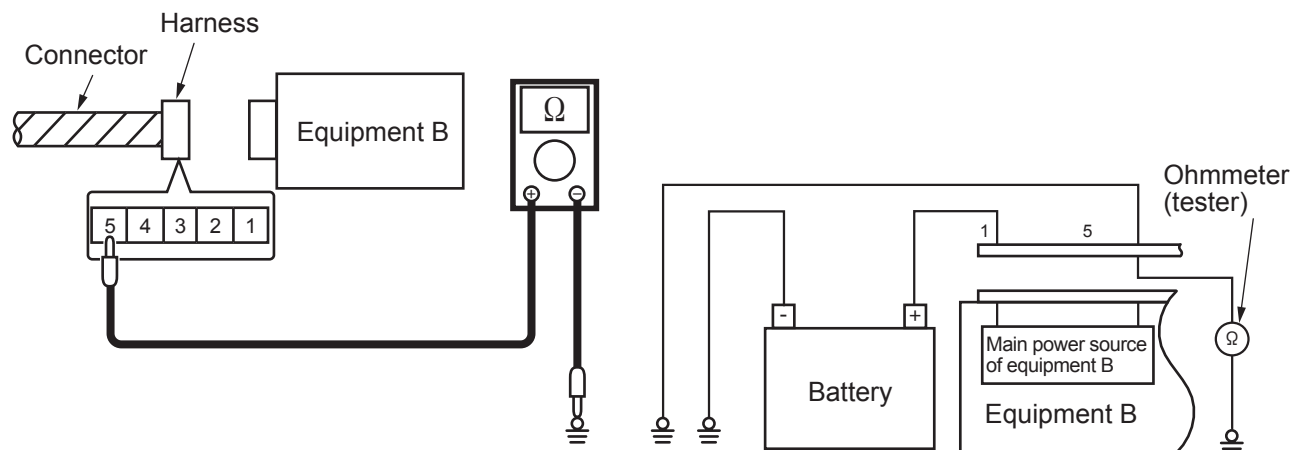

Inspection procedure

- ① Disconnect the connector of equipment B.
- ② Connect the test probe (+) to connector terminal 5 of equipment B and the test probe (-) to a vehicle ground point (the bolt fastening the ground terminal or an unpainted portion on the body) and measure the resistance. At this time, reversing the connector terminals between the probes (+) and (-) does not make any difference in the measurement.

(NOTICE)

- When measuring the resistance, connect the test probes to both ends of the portion to be measured. Make also sure that no voltage is applied to the portion to be measured.
- When measuring the internal resistance of equipment, be sure first to disconnect all harnesses from the equipment.
- When measuring the resistance of a harness, disconnect the equipment connected to both ends of the harness.

2) Measuring voltage using tester

2-1) Measuring voltage of equipment A (measuring voltage between terminals 1 and 3)

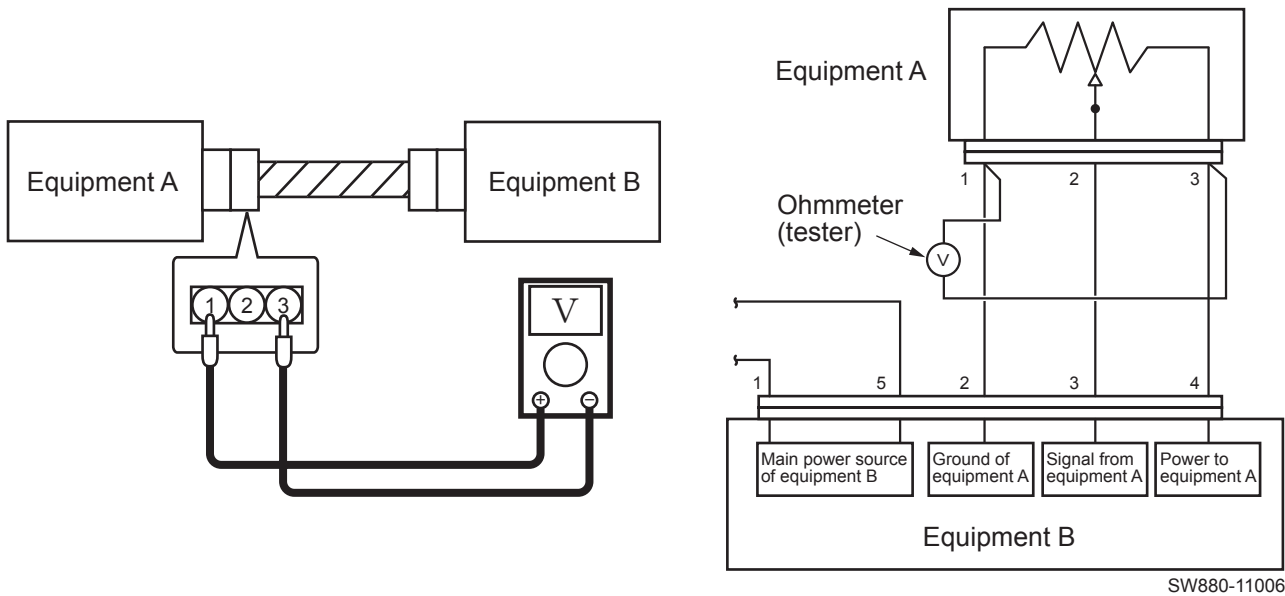

SW880-11006

Inspection procedure

- ① Connect the connectors of equipment A and that of equipment B.
- ② Connect the test probe (+) to connector terminal 1 of equipment A and the test probe (-) to connector terminal 3 of equipment A and measure the voltage. Note that reversing the connector terminals between the probes (+) and (-) changes the result of the measurement. Be sure to connect the probe (+) to the power source side and the probe (-) to the ground side.

(NOTICE)

- When measuring the voltage, connect the tester in parallel to the portion to be measured. The voltage can be measured only when the test probes are connected to the terminals with the connectors connected in position. For that purpose, the following measurement methods are available: preparing a test harness; inserting a needle from the backside of the connector; or removing the tape from the harness to separate each wire and sticking a needle into the relevant wire. Inserting a needle from the backside of the connector and sticking a needle into a relevant wire could result in corroded connector terminal or harness interior.

2-2) Measuring current flowing from equipment B to equipment A
(measuring current between terminal 2 of equipment B and terminal 1 of equipment A)

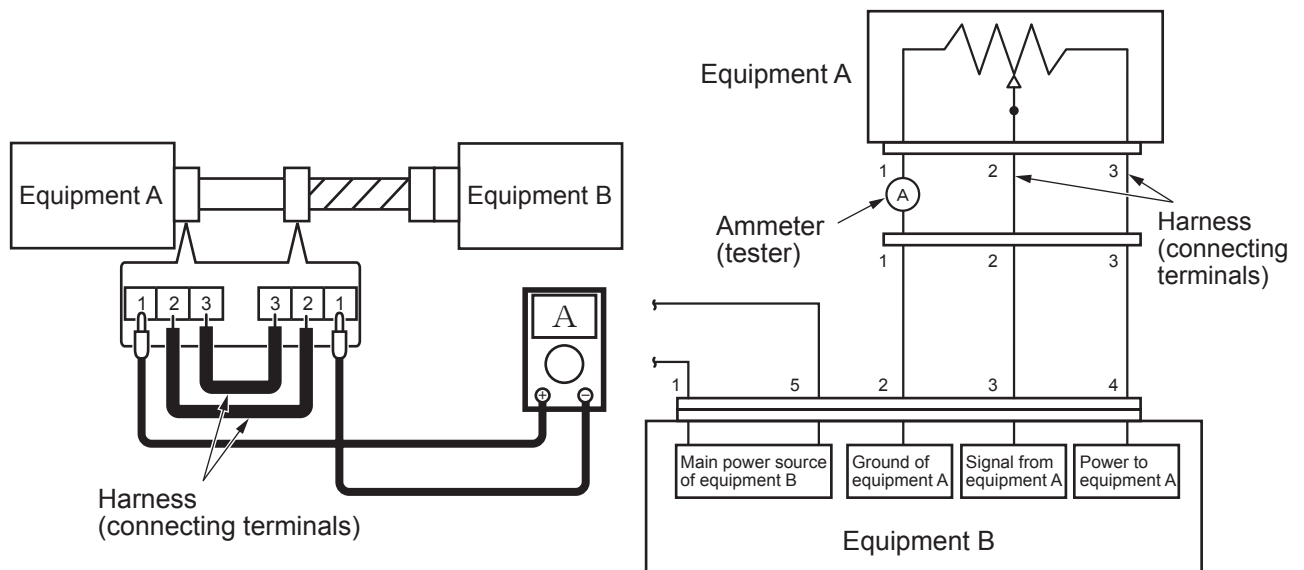

SW880-11007

Inspection procedure

- ① Disconnect the connector of equipment A.
- ② Connect the terminals other than those to be measured using a harness.
(Be sure to use a harness with a jacket.)
- ③ Connect the test probe (+) to connector terminal 1 (harness side) of equipment A and the test probe (-) to connector terminal 1 (equipment side) of equipment A and measure the current. Note that reversing the connector terminals between the probes (+) and (-) changes the result of the measurement. Be sure to connect the probe (+) to the power source side and the probe (-) to the ground side.

(NOTICE)

- When measuring the current, connect the tester in series to the portion to be measured. Although the connector needs to be disconnected to allow the test probes to connect to the terminals, the terminals other than those used for measurement must be connected because otherwise the equipment will not operate properly. For that purpose, the following measurement methods are available: preparing a test harness or connecting the tester to the portion to be measured with the connector disconnected and making a connection with other terminals using a harness. Measuring the current with the terminals other than those used for measurement connected using a harness could result in a short circuit between the terminals.

2-1-3. Inspection of electrical system

Operate the applicable switches and turn the relays ON and OFF. Ultimately, if the solenoid valve operates (makes a sound) and the pump runs, the electrical system is OK.

If there is a failure (fault), narrow the range of the inspection to the six broad steps described below.

1) Ground inspection

- Check for disconnected or loose ground. If rust or corrosion is present (which can cause faulty contact), remove the rust.

2) Fuse inspection

2-1) Check for blown fuses disconnections and corrosion.

(A fatigue open circuit cannot be identified visually. Use a tester for checking.)

2-2) If a fuse is blown

Check whether a pump or valve (that is supposed to be protected by a blown fuse) burned, and whether there is a burning odor.

Check the harness for signs of burning. If it is burned, replace it.

If a fuse is blown and a relay along the pathway has failed, replace it. And if there is a timer, replace the timer, too. If a switch visually appears to be unsatisfactory (burned, melted, etc.) even though it operates, replace it.

- Simply replacing a fuse may not eliminate the true cause of a problem, and over current may flow again. Also, if over current secondarily causes an electrical path to fail (such as a wiring meltdown inside a solenoid valve), current will not flow. Thus, a fuse may not blown out, but it also will not operate. If you do not know the location of burning or of an odor, investigate as described follows.

2-3) How to find cause of failure when fuse blown is reproduced

- ① Turn the starter switch OFF, and remove the connector from the load (valve, pump).
- ② Referring to the circuit diagram, remove electrical parts that are connected to the circuit, such as relays, timers and diodes.
- ③ Turn the starter switch ON, and see whether the conditions can be reproduced (fuse is blown).
- ④ If a fuse is blown, a part such as a relay may have caused a short between the previous harness and ground (vehicle body). (Replace the harness.) If the conditions are not reproduced, check for signs of burning (odor) on the removed electrical parts.
- ⑤ If there is no problem, turn the starter switch OFF and reattach the parts.
- ⑥ Turn the starter switch ON and try again.
- ⑦ If a fuse is blown with this action, the problem was caused by a short between the harness and ground (vehicle body) that followed the attached electrical part. (Replace the harness.)
- ⑧ If the conditions are not reproduced, turn the starter switch OFF, and connect the loads (valve and pump) one at a time. Turn the starter switch ON and try again to see whether the fuse blown is reproduced.
- ⑨ If the fuse blown is reproduced, whatever was added at that time (including a harness added electrically) will be the cause of the failure.

- Even if the fuse is not blown and the valve or pump is not burned, the valve or pump may be damaged electrically and may not operate. There may simply be a disconnection in the interior or an abnormal heat-up.
- Even if the fuse is not blown, abnormal heat-up (hot enough to cause burns if touched) may occur if a relay, timer, diode or other semiconductor fails.

3) Connector inspection

- Is a connector disconnected or loose?
- Check that pins are not snapped or corroded.
- If faulty contact is suspected

Turn the starter switch OFF. Then disconnect and check the connectors (including relay and switch sockets). If the terminal has no luster, faulty contact due to oxidation can be suspected. Therefore, polish the terminal by inserting and removing the connector (relay, switch) repeatedly at least five times. (Luster will return.)

4) Relay inspection (Check ON/OFF operation by sound.)

- Conduct without running the engine. (If you run the engine, you cannot hear the sound of operation.)

Sound heard : The relay and wiring on the relay coil side are normal.

No sound heard: Turn the starter switch OFF temporarily, replace the relay, and inspect again.

Sound heard : A relay failure occurred.

Still no sound : Using a tester, check the harness.

Continuity : Turn the starter switch OFF temporarily, disconnect the relay and check for continuity between the harness-side grounding terminal (color: black) and vehicle body ground. (If there is none, replace the harness.)

Voltage : With the relay disconnected, turn the starter switch ON and turn the operating switch ON. 24V (or 12V) (between vehicle body ground) should not reach the relay coil input terminal. Confirm this.

Identify the location (section) to which 24V (or 12V) reaches. Then replace the harness or take other action.

5) Solenoid valve inspection (Check ON/OFF operation by sound.)

- Conduct without running the engine. (If you run the engine, you cannot hear the sound of operation.)

Sound heard : The electrical system is normal.

No sound heard: Check with a tester.

Continuity : ① Turn the starter switch OFF temporarily, disconnect the connector and check for continuity between the harness-side grounding terminal (color: black) and vehicle body ground. (If there is none, replace the harness.)

: ② Is the solenoid valve coil burnt?

(Turn the starter switch OFF, disconnect the connector and check the resistance between the solenoid valve terminal.)

Voltage : With the connector disconnected, turn the starter switch ON and check whether 24V (or 12V) exists between the harness-side connector and vehicle body ground.

If YES : Replace the valve.

If NO : Investigate and identify the location (section) to which 24V (or 12V) reaches. Then replace the harness or take other action.

6) Harness check

- If an incomplete disconnection inside the harness is suspected, wiggle (move) the harness during the relay inspection and solenoid valve inspection to see whether the relay (valve) operates incorrectly.
- Check for burned areas of the harness.
- Turn the starter switch OFF, disconnect the connector and check the continuity, referring to the circuit diagram and wiring coloring.

2-2. Blink Codes

2-2-1. Description of blink codes

- The engine control unit constantly monitors the input and output status to control each system.
- The engine control unit performs the system diagnostics function. When any system problem is detected, it illuminates the warning lamp and stores the blink code in memory.
- The statuses are displayed by the engine check lamp.

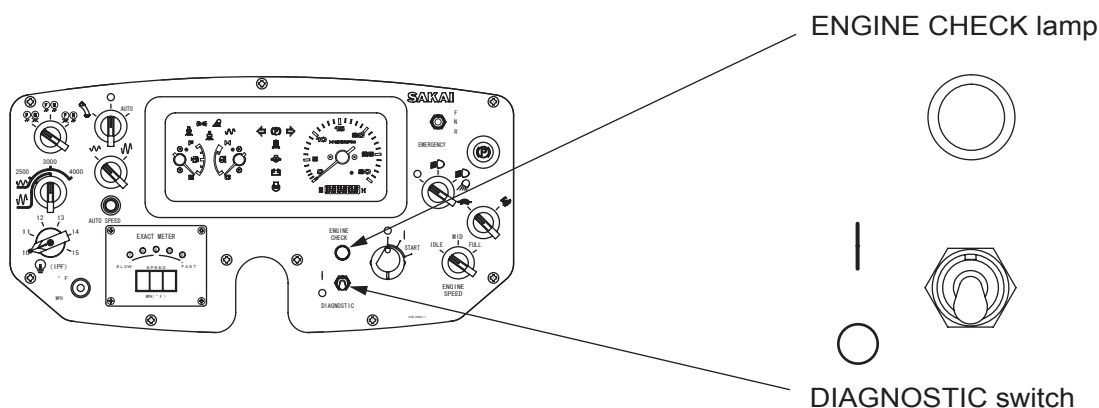

Lamp check : The lamp lights up for approx. 2 sec. after switching on the starter switch.

Steady light : A system error or an engine variable value (temperature or pressure etc.) is in the warning range is occurred.

Fast flashing: The engine is in danger condition. Stop the vehicle immediately as soon as it is safe to do so.

Blink code checking procedure:

- ① Actuating the DIAGNOSTIC switch for more than 2 seconds.
- ② The ENGINE CHECK lamp goes out and first fault is output as a blink code after releasing the DIAGNOSTIC switch.
- ③ When the blink code disappears, the lamp goes out and remains off for 5 seconds.
- ④ If the control unit has stored other blink codes in memory, actuating the diagnosis switch displays the next code.
- ⑤ Actuating the switch again displays the first code.
- ⑥ After the fault has been repaired, turn off the ignition switch. When the ignition switch is turned on again 30 seconds after that, the lamp goes out.

Example of blink code display

Example: Blink code 2-1-4

The lamp lights up 0.4 second twice, 0.8 second once and then 0.4 seconds four times.

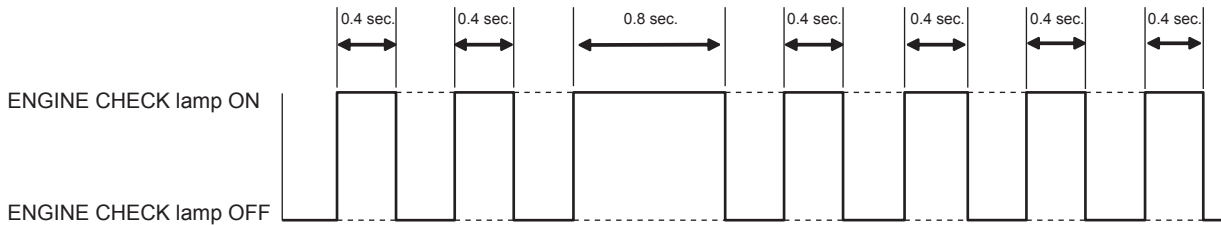

SW880-11008

(NOTICE)

- The SERDIA code can be read by connecting a German-made diagnosis tester to the diagnosis connector. The SERDIA (SERvice DIAGnosis) code allows you to identify the cause of the fault in greater detail than the blink code.

2-2-2. Blink code list

Blink code			SERDIA code	Description
Short (0.4 sec.)	Long (0.8 sec.)	Short (0.4 sec.)		
1	1	1	112	Faulty CAN
1	1	2	113	Faulty CAN
1	1	5	117	Faulty CAN
1	1	6	118	Faulty CAN
1	1	8	120	Faulty CAN
			122	
			124	
			125	
			127	
1	1	9	121	Faulty CAN
			123	
			126	
			128	
1	2	3	54	Faulty coolant temperature warning lamp
1	2	6	138	Faulty hand throttle
1	2	8	149	Defective intake air temperature sensor
1	3	3	136	Temperature sensor 1
			137	
1	3	4	211	Faulty rail pressure
			212	
			213	
			214	
			215	
			216	

TROUBLESHOOTING

Blink code			SERDIA code	Description
Short (0.4 sec.)	Long (0.8 sec.)	Short (0.4 sec.)		
1	3	5	176	Faulty metering unit valve
			177	
			178	
			179	
			195	Faulty oil pressure warning lamp
1	3	6	11	Faulty air filter condition
1	3	7	182	Faulty main relay
1	3	8	183	
1	3	9	184	ECU internal defect
1	4	2	81	Faulty engine operating signal lamp
1	4	3	189	Faulty engine speed switch 1
			190	Faulty engine speed switch 2
			191	Faulty engine speed switch 3
1	4	4	201	Faulty oil temperature sensor
1	4	5	200	Faulty override switch
1	4	6	208	Faulty rail pressure limit valve
			236	
1	4	7	209	Faulty rail pressure sensor
			210	
1	4	9	218	ECU internal defect
1	5	1	153	Multiple faulty injectors
			154	
1	5	2	155	Multiple faulty injectors
			156	
1	5	3	157	ECU internal defect
			158	
1	5	4	159	Faulty injector 1
			160	
1	5	5	161	Faulty injector 2
			162	
1	5	6	163	Faulty injector 3
			164	
1	6	1	165	Faulty injector 4
			166	
1	6	2	167	Faulty injector 5
			168	
1	6	3	169	Faulty injector 6
			170	
1	6	4	171	Faulty injector 7
			172	
1	6	5	173	Faulty injector 8
			174	

Blink code			SERDIA code	Description
Short (0.4 sec.)	Long (0.8 sec.)	Short (0.4 sec.)		
2	1	2	75	Faulty engine speed signal
			76	
			77	
2	1	3	78	Faulty engine speed signal
2	1	4	79	Over speed or overrun
			80	
2	1	6	90	Faulty fuel low-pressure sensor
			91	
2	1	9	82	Faulty engine brake flap actuator
2	2	2	14	Faulty accelerator
			15	
2	2	3	32	Faulty intake pressure sensor
			33	
2	2	4	196	Faulty oil pressure sensor
2	2	5	55	Faulty coolant temperature sensor
2	2	6	12	Faulty accelerator
2	2	7	133	Faulty fuel temperature sensor
2	2	8	87	Faulty fuel filter sensor (sedimentor)/Faulty water level inside fuel filter (sedimentor)
			89	
2	3	1	197	Faulty oil pressure sensor
			198	
			199	
2	3	2	56	Faulty coolant temperature
2	3	3	150	Faulty intake air temperature
2	3	5	37	Faulty coolant level
2	3	7	134	Faulty fuel temperature
2	3	8	83	Faulty fan speed actuator
			86	Faulty fan speed
2	4	1	38	Detection of misfire
			39	
			40	
			41	
			42	
			43	
			44	
			45	
			46	
47				
2	6	1	186	Faulty main relay
			187	
			188	

TROUBLESHOOTING

Blink code			SERDIA code	Description
Short (0.4 sec.)	Long (0.8 sec.)	Short (0.4 sec.)		
2	6	3	18	Faulty air heater valve
			17	Faulty air heater relay
			19	
			20	
2	7	1	131	Faulty CAN
			192	
			193	
			194	
2	8	1	142	ECU internal defect
2	8	2	219	ECU internal defect
			221	
			222	
2	9	2	16	ECU internal defect
3	1	4	139	Faulty temperature sensor 2
			140	
3	1	8	22	Faulty battery voltage
			23	
3	2	8	53	Faulty glow lamp
3	3	3	106	Faulty CAN
3	3	7	110	Faulty CAN
3	4	1	48	Faulty shutoff request
4	1	4	69	Faulty EGR actuator
			70	
4	1	5	71	Faulty EGR actuator
4	1	6	72	Faulty EGR actuator
5	1	2	223	Faulty start relay
			224	
5	1	3	225	Faulty fault indicator lamp (engine check lamp)
5	1	4	226	Faulty ignition ON detection
5	1	5	227	Faulty engine start switch
5	2	1	232	Faulty vehicle speed signal
5	2	6	94	Faulty CAN
5	2	7	95	Faulty CAN
5	2	8	52	Faulty engine brake
5	3	1	24	Faulty No. 1 cylinder injection start timing
5	3	2	25	Faulty No. 2 cylinder injection start timing
5	3	3	26	Faulty No. 3 cylinder injection start timing
5	3	4	27	Faulty No. 4 cylinder injection start timing
5	3	5	28	Faulty No. 5 cylinder injection start timing
5	3	6	29	Faulty No. 6 cylinder injection start timing
5	3	7	30	Faulty No. 7 cylinder injection start timing
5	3	8	31	Faulty No. 8 cylinder injection start timing

Blink code			SERDIA code	Description
Short (0.4 sec.)	Long (0.8 sec.)	Short (0.4 sec.)		
5	5	5	74	Faulty engine output
			175	Faulty rail pressure
			141	ECU internal defect
			143	
			144	
			145	
			146	
			147	
			228	
			235	

2-3. Error Codes

2-3-1. Description of error codes

- The vehicle control unit (V/C) constantly monitors the input and output status to control each system.
- The vehicle control unit (V/C) performs the system diagnostics function. When any system problem is detected, it displays the corresponding error code on the multiple display.

2-3-2. Error code list

Error code	Description	Symptom
E01	Faulty potentiometer inside forward-reverse lever	Inoperative vehicle
E02		
E03		
E04		
E05		
E06		
E11	Faulty speed sensor	Exact meter indicator lamp does not light. Automatic speed function does not operate. Vehicle speed is not displayed.
E15	Faulty road surface temperature sensor	Display does not switch to temperature indication.
E21	Faulty frequency selector switch (three input signals)	Automatic speed function does not operate. Vibration does not occur or frequency cannot be changed.
E22	Faulty IPF selector switch (four input signals)	Automatic speed function does not operate.
E31	Faulty front travel proportional valve output current	Inoperative vehicle
E32	Faulty rear travel proportional valve output current	Inoperative vehicle
E33	Faulty left vibration proportional magnetic valve output current	Vibration does not occur or frequency cannot be changed.
E34	Faulty right vibration proportional magnetic valve output current	Vibration does not occur or frequency cannot be changed.
E41	Faulty CAN communication	Automatic speed function does not operate. Tachometer in combination meter does not work.
E42	Defect between display and controller	Exact meter indicator lamp does not light. Vehicle speed is not displayed.

Fig. : 2-4-1

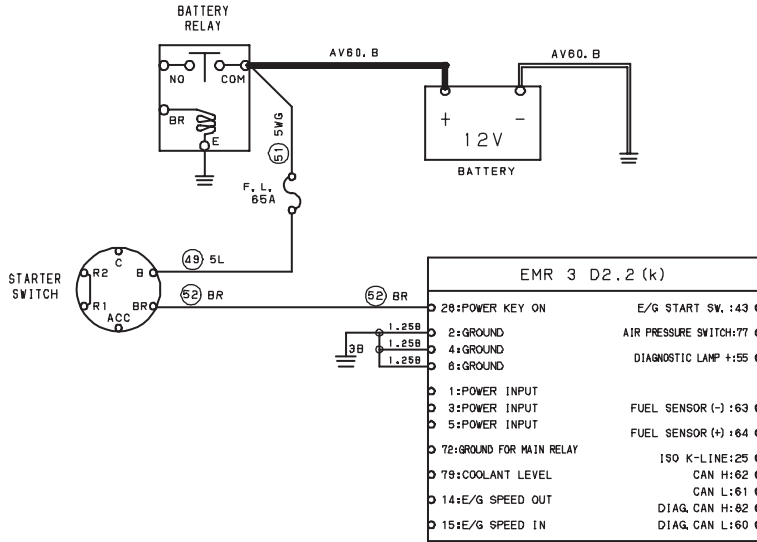

EMR CONNECTOR																			
1	2	3	4	5	6	7	8	9	10	11	12	13	14	15	16	17	18	19	20
94	X	94	X	94	X	*	*	*	*	*	*	*	Br-R	Rw	*	*	*	*	*
1.25YR	1.25YR	1.25YR	1.25B	1.25YR	1.25B	*	*	*	*	*	*	*	*	*	*	*	*	*	*
21	22	23	24	25	26	27	28	29	30	31	32	33	34	35	36	37	38	39	40
*	*	*	*	104	*	*	52	*	*	*	*	*	*	*	*	*	*	*	*
*	*	*	*	Br-Y	*	*	BR	*	*	*	*	*	*	*	*	*	*	*	*
41	42	43	44	45	46	47	48	49	50	51	52	53	54	55	56	57	58	59	60
*	*	30	*	*	*	*	*	*	*	*	*	*	*	103	*	*	*	*	108
*	*	BY	*	*	*	*	*	*	*	*	*	*	*	LR	*	*	*	*	Y
61	62	63	64	65	66	67	68	69	70	71	72	73	74	75	76	77	78	79	80
106	105	101	102	*	*	*	*	*	*	*	95	*	*	*	*	109	*	111	*
RY	RB	GR	GY	*	*	*	*	*	*	*	BY	*	*	*	P	*	Lwb	*	*
81	82	83	84	85	86	87	88	89	90	91	92	93	94						
*	107	*	*	*	*	*	*	*	*	*	*	*	*						
*	YB	*	*	*	*	*	*	*	*	*	*	*	*						

Twist shield cable

- The arrangement of connector terminals shown above is that of connecting surface on the connector side.
- Terminals marked with asterisks are not in use.

Twist shield cable

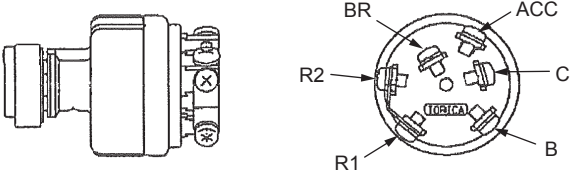
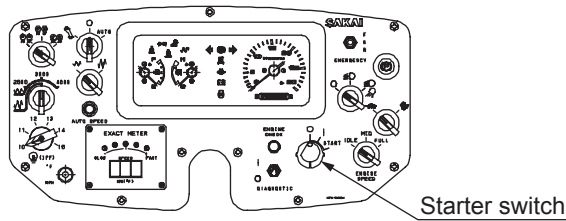
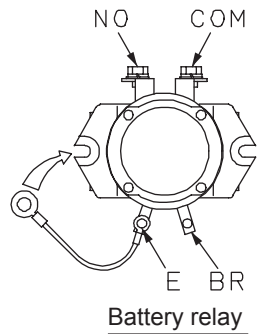
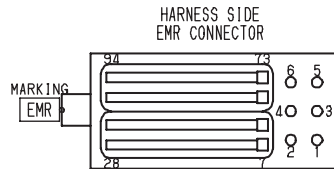

Terminal	B	R1	R2	ACC	BR	C
Key position						
HEAT	○	○	○	○	○	
OFF						
ON	○			○	○	
START	○	○	○	○	○	○

Starter switch connection table

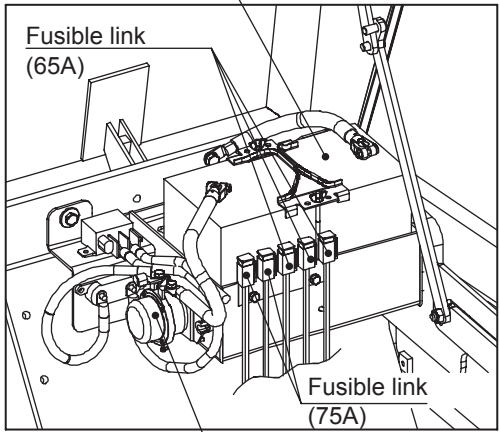

2-4. Engine

Check the following items before troubleshooting.

- The forward-reverse lever is in the “neutral” position.
- No fuse blew.
- The parking brake switch is ON.
- Check any ground circuit which belongs to the components to be checked.

2-4-1. Engine will not start (1/8)

Reference Fig. : 2-4-1

1) When engine check lamp is illuminated or flashing

Blink code	Check point	Check/Cause	Action
3-1-8 or 5-1-4	1. Connector	- Check the battery and EMR 3 connector (pin 28) for corrosion, breakage, bending and looseness. - If any abnormality is found, the connector is faulty.	Replace the connector or terminal.
	2. Harness	(1) Measure the resistance between the starter switch terminal BR wire and the EMR 3 connector pin 28 BR wire. Standard resistance: 10 Ω or less (2) Measure the resistance between the starter switch terminal L wire and the battery relay terminal WG wire. Standard resistance: 10 Ω or less - If the resistance is abnormal, the harness or fusible link is faulty.	Repair or replace the harness or fusible link.
	3. Battery	- Measure the battery voltage or specific gravity. Standard voltage: 12V or more Standard specific gravity: 1.26 or more - If the measured value is below standard, the battery capacity is insufficient.	Charge or replace the battery.
	4. EMR 3	- If either the blink code 3-1-8 or 5-1-4 flashes and no abnormality is found in the connector, harness or battery in the above inspections, the EMR 3 is faulty.	Replace the EMR 3.

Fig. : 2-4-2

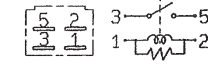
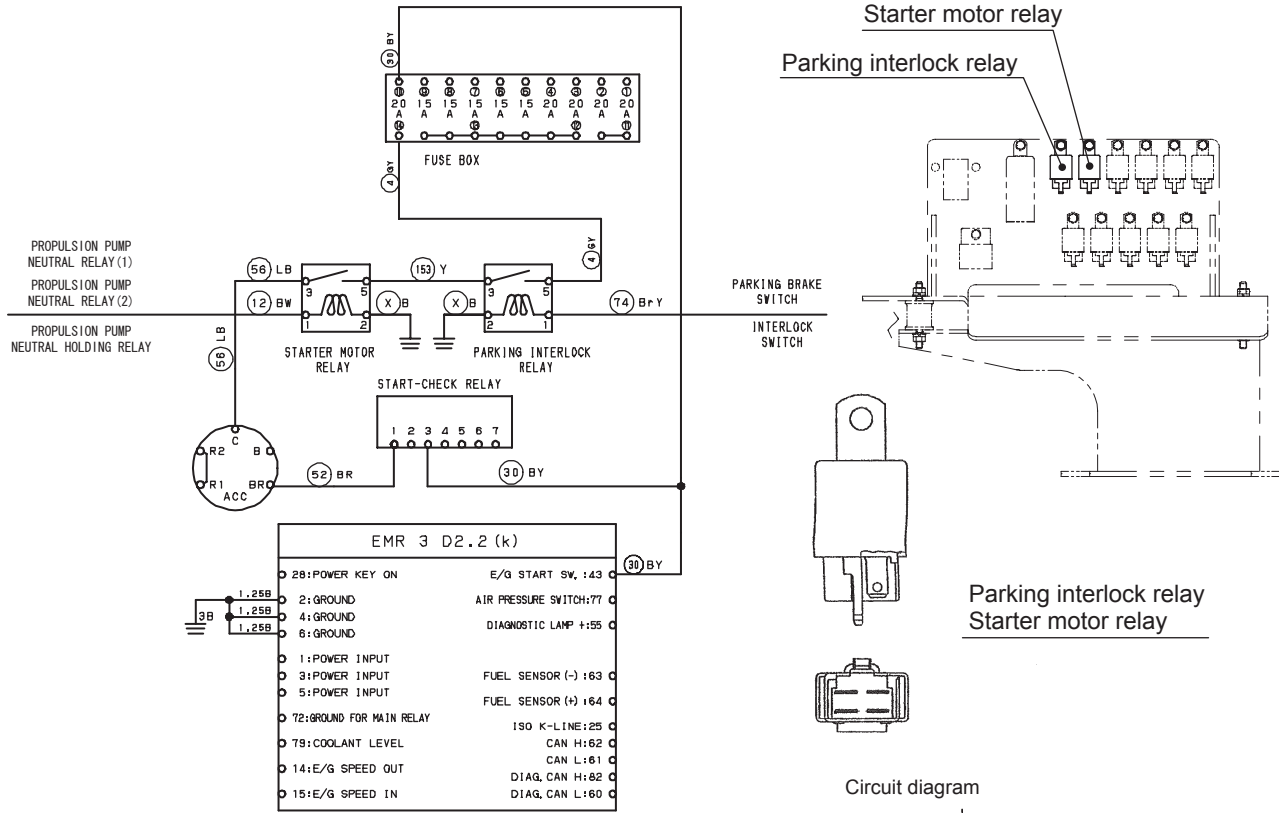

EMR CONNECTOR																				
1	2	3	4	5	6	7	8	9	10	11	12	13	14	15	16	17	18	19	20	
94	X	94	X	94	X	*	*	*	*	*	*	*	*	*	97	96	*	*	*	*
		1,25B	1,25B	1,25B	1,25B										Br/R	Rv				
21	22	23	24	25	26	27	28	29	30	31	32	33	34	35	36	37	38	39	40	
*	*	*	104	*	*	52	*	*	*	*	*	*	*	*	*	*	*	*	*	*
			Br/Y			BR														
41	42	43	44	45	46	47	48	49	50	51	52	53	54	55	56	57	58	59	60	
*	*	30	*	*	*	*	*	*	*	*	103	*	*	*	58	58	111	*	108	
		BY									BY			LR					Y	
61	62	63	64	65	66	67	68	69	70	71	72	73	74	75	76	77	78	79	80	
108	105	101	102	*	*	*	*	*	*	*	*	*	*	*	*	*	*	*	*	*
Ry	Rb	Gr	Gy								BY				P				LbB	
81	82	83	84	85	86	87	88	89	90	91	92	93	94							
*	107	*	*	*	*	*	*	*	*	*	*	*	*							
	Yb																			

Twist shield cable

- The arrangement of connector terminals shown above is that of connecting surface on the connector side.
- Terminals marked with asterisks are not in use.

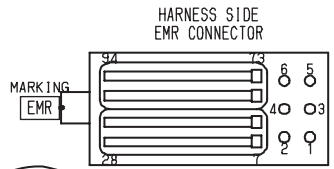

The arrangement of connector terminals shown above is that of connecting surface on the connector side.

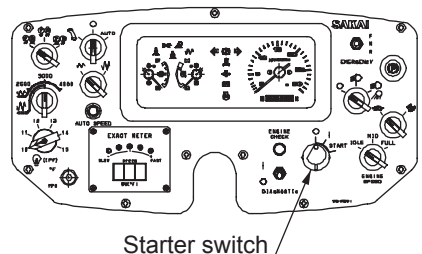
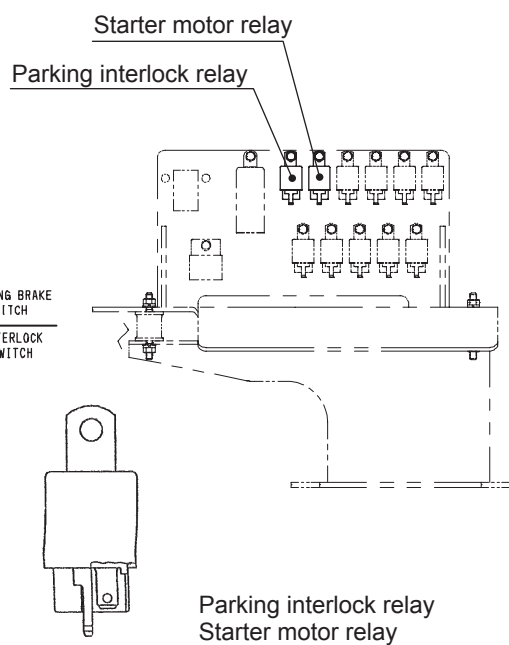
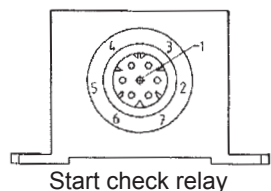

Twist shield cable

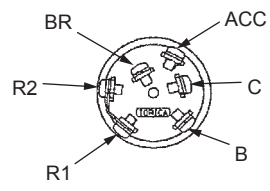
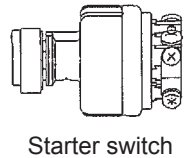

Key position	Terminal					
	B	R1	R2	ACC	BR	C
HEAT	○	○	○	○	○	
OFF						
ON	○					
START	○	○	○	○	○	

Starter switch connection table

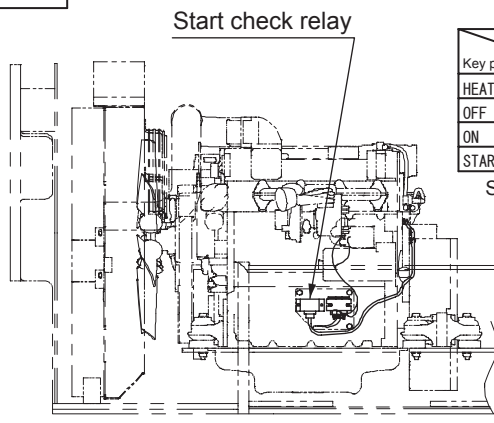

2-4-1. Engine will not start (2/8)**Reference Fig. : 2-4-2**

1) When engine check lamp is illuminated or flashing

Blink code	Check point	Check/Cause	Action
5-1-2 or 5-1-5	1. Connector	- Check the parking brake relay, starter motor relay, start check relay and EMR 3 connector (pin 43) for corrosion, breakage, bending and looseness. - If any abnormality is found, the connector is faulty.	Replace the connector or terminal.
	2. Harness	(1) Measure the resistance between the starter switch terminal BR wire and the start check relay pin 1 BR wire. Standard resistance: 10 Ω or less (2) Measure the resistance between the start check relay pin 3 BY wire and the EMR 3 connector pin 43 BY wire. Standard resistance: 10 Ω or less (3) Measure the resistance between the EMR 3 connector pin 43 BY wire and the fuse box pin 10 BY wire. Standard resistance: 10 Ω or less (4) Measure the resistance between the fuse box pin 14 GY wire and the parking interlock relay pin 5 GY wire. Standard resistance: 10 Ω or less (5) Measure the resistance between the parking interlock relay pin 3 Y wire and the starter motor relay pin 5 Y wire. Standard resistance: 10 Ω or less (6) Measure the resistance between the starter motor relay pin 3 LB wire and the starter switch terminal LB wire. Standard resistance: 10 Ω or less - If the resistance is abnormal, the harness is faulty.	Repair or replace the harness.
	3. Parking Interlock Relay	(1) When the starter switch is ON, measure the voltage between the parking interlock relay pin 1 inlet BrY wire and the chassis ground. Standard voltage: 12V or more (2) When the starter switch is ON, measure the voltage between the parking interlock relay pin 5 inlet GY wire and the chassis ground. Standard voltage: 12V or more (3) When the starter switch is ON, measure the voltage between the parking interlock relay pin 3 inlet Y wire and the chassis ground. Standard voltage: 12V or more - If the above items (1) and (2) are OK and the item (3) is NG, the parking interlock relay is faulty.	Replace the parking interlock relay.

Fig. : 2-4-2

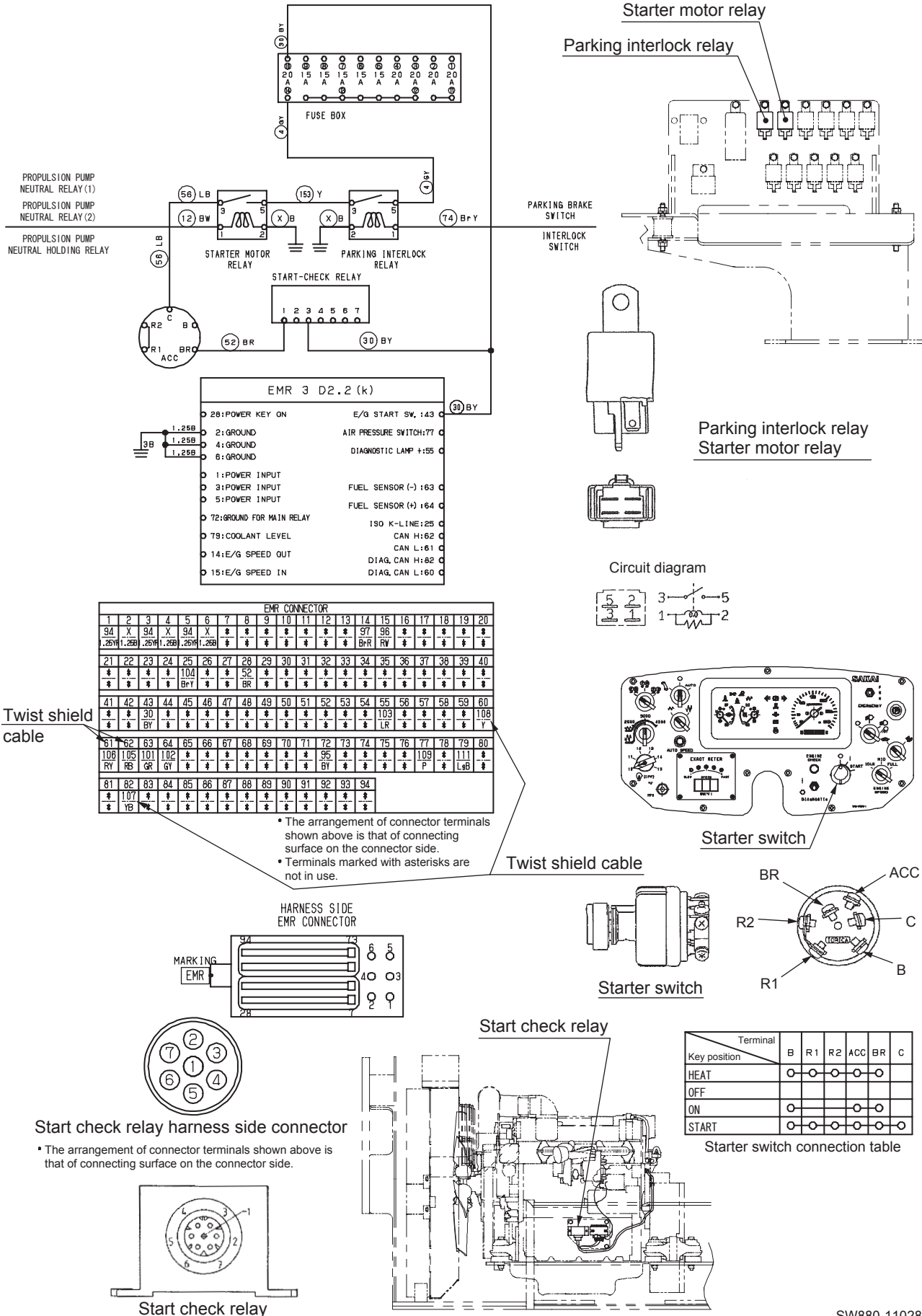

2-4-1. Engine will not start (3/8)**Reference Fig. : 2-4-2**

1) When engine check lamp is illuminated or flashing

Blink code	Check point	Check/Cause	Action
5-1-2 or 5-1-5	4. Starter Motor Relay	<p>(1) When the starter switch is ON, measure the voltage between the starter motor relay pin 1 inlet BW wire and the chassis ground. Standard voltage: 12V or more</p> <p>(2) When the starter switch is ON, measure the voltage between the starter motor relay pin 5 inlet Y wire and the chassis ground. Standard voltage: 12V or more</p> <p>(3) When the starter switch is ON, measure the voltage between the starter motor relay pin 3 inlet LB wire and the chassis ground. Standard voltage: 12V or more</p> <p>- If the above items (1) and (2) are OK and the item (3) is NG, the starter motor relay is faulty.</p>	Replace the starter motor relay.
	5. Start Check Relay	<p>(1) When the starter switch is ON, measure the voltage between the start check relay pin 1 BR wire and the chassis ground. Standard voltage: 12V or more</p> <p>(2) When the starter switch is START, measure the voltage between the start check relay pin 3 BY wire and the chassis ground. Standard voltage: 12V or more</p> <p>(3) When the starter switch is START, measure the voltage between the start check relay pin 5 and the chassis ground. Standard voltage: 12V or more</p> <p>- If the above items (1) and (2) are OK and the item (3) is NG, the start check relay is faulty.</p>	Replace the start check relay.
	6. Starter Switch	<p>- Check the continuity between O and O according to the starter switch connection table. The switch is OK if there is continuity between the connections O–O of all the switch positions.</p> <p>- If there is no continuity, the starter switch is faulty.</p>	Replace the starter switch.
	7. EMR 3	- If either the blink code 5-1-2 or 5-1-5 flashes and no abnormality is found in the connector, harness, parking interlock relay, starter motor relay, start check relay and starter switch in the above inspections, the EMR 3 is faulty.	Replace the EMR 3.

Fig. : 2-4-3

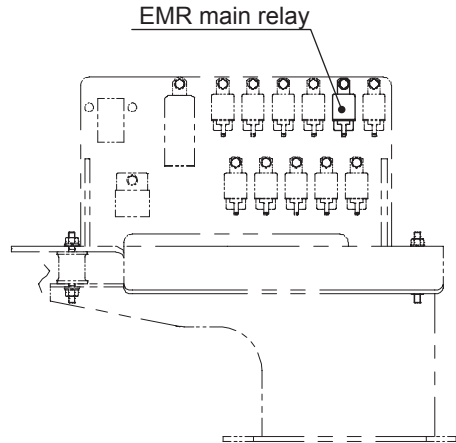
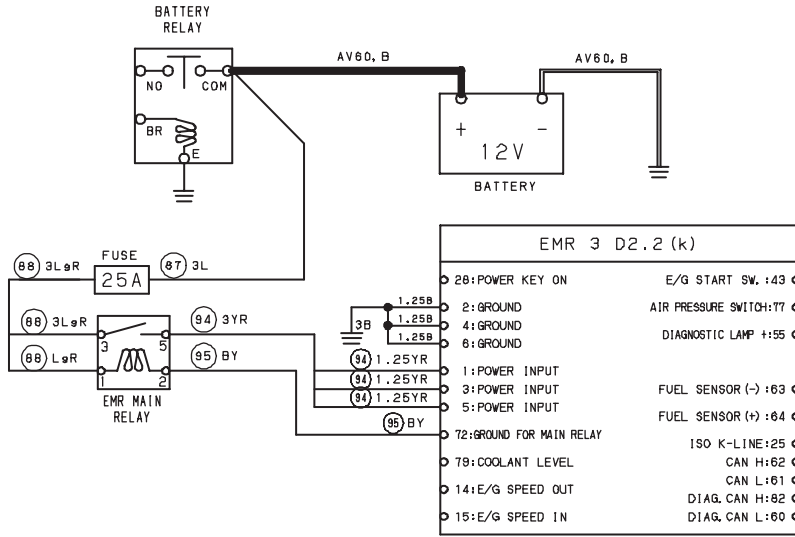

EMR CONNECTOR

1	2	3	4	5	6	7	8	9	10	11	12	13	14	15	16	17	18	19	20
94	X	94	X	94	X	*	*	*	*	*	*	97	96	*	*	*	*	*	*
1.25Y	1.25B	1.25Y	1.25B	1.25Y	1.25B	*	*	*	*	*	*	BR	RV	*	*	*	*	*	*
21	22	23	24	25	26	27	28	29	30	31	32	33	34	35	36	37	38	39	40
*	*	*	*	104	*	*	52	*	*	*	*	*	*	*	*	*	*	*	*
*	*	*	*	BY	*	*	BR	*	*	*	*	*	*	*	*	*	*	*	*
41	42	43	44	45	46	47	48	49	50	51	52	53	54	55	56	57	58	59	60
*	*	30	*	*	*	*	*	*	*	*	*	*	*	103	*	*	*	*	108
*	*	BY	*	*	*	*	*	*	*	*	*	*	*	LR	*	*	*	*	Y
61	62	63	64	65	66	67	68	69	70	71	72	73	74	75	76	77	78	79	80
106	105	101	102	*	*	*	*	*	*	*	95	*	*	*	*	109	*	111	*
RY	RB	GR	GY	*	*	*	*	*	*	*	BY	*	*	*	P	*	LGB	*	*
81	82	83	84	85	86	87	88	89	90	91	92	93	94						
*	107	*	*	*	*	*	*	*	*	*	*	*	*						
*	YB	*	*	*	*	*	*	*	*	*	*	*	*						

Twist shield cable

- The arrangement of connector terminals shown above is that of connecting surface on the connector side.
- Terminals marked with asterisks are not in use.

Twist shield cable

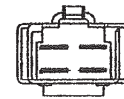

HARNESS SIDE EMR CONNECTOR

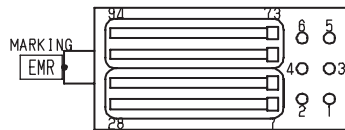

Circuit diagram

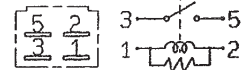

EMR main relay

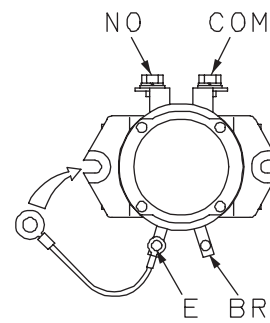
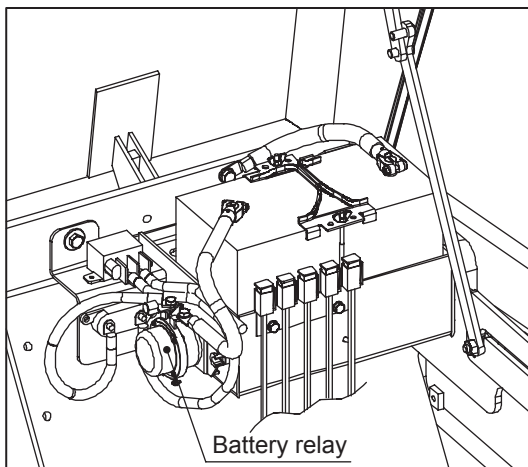

Battery relay

2-4-1. Engine will not start (4/8)**Reference Fig. : 2-4-3**

1) When engine check lamp is illuminated or flashing

Blink code	Check point	Check/Cause	Action
1-3-7, 1-3-8 or 2-6-1	1. Connector	- Check the EMR 3 main relay and EMR 3 connector (pins 1, 3, 5 and 72) for corrosion, breakage, bending and looseness. - If any abnormality is found, the connector is faulty.	Replace the connector or terminal.
	2. Harness	(1) Measure the resistance between the battery relay terminal L wire and the EMR main relay pin 1 LgR wire and the resistance between the battery relay terminal L wire and the EMR main relay pin 3 LgR wire. Standard resistance: 10 Ω or less (2) Measure the resistance between the EMR main relay pin 5 YR wire and the EMR 3 connector pin 1, 3 and 5. Standard resistance: 10 Ω or less (3) Measure the resistance between the EMR main relay pin 2 BY wire and the EMR 3 connector pin 72. Standard resistance: 10 Ω or less - If the resistance is abnormal, the harness or fuse (25A) is faulty.	Repair or replace the harness or fuse (25A).
	3. EMR Main Relay	(1) Measure the resistance between the EMR main relay pin 1 inlet LgR wire and the chassis ground. Standard voltage: 12V or more (2) Measure the resistance between the EMR main relay pin 3 inlet LgR wire and the chassis ground. Standard voltage: 12V or more (3) Measure the resistance between the EMR main relay pin 5 inlet YR wire and the chassis ground. Standard voltage: 12V or more - If the above items (1) and (2) are OK and the item (3) is NG, the EMR main relay is faulty.	Replace the EMR main relay.
	4. EMR 3	- If any of the blink codes 1-3-7, 1-3-8 and 2-6-1 flashes and no abnormality is found in the connector, harness and EMR main relay in the above inspections, the EMR 3 is faulty.	Replace the EMR 3.
2-8-2, 2-9-2 or 5-5-5	1. EMR 3	- When the starter switch is ON, check that the voltage between the EMR 3 connector pins 1, 3 and 5 YR wires and pins 2, 4 and 6 B wires and the voltage between the EMR 3 connector pin 28 BR wire and pins 2, 4 and 6 B wires are in the standard range. Standard voltage: 12V or more - If the above item is OK, the EMR 3 interior is faulty.	Replace the EMR 3.

Fig. : 2-4-4

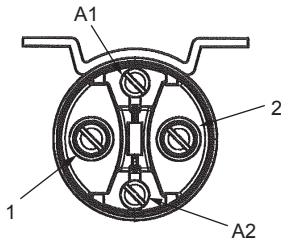
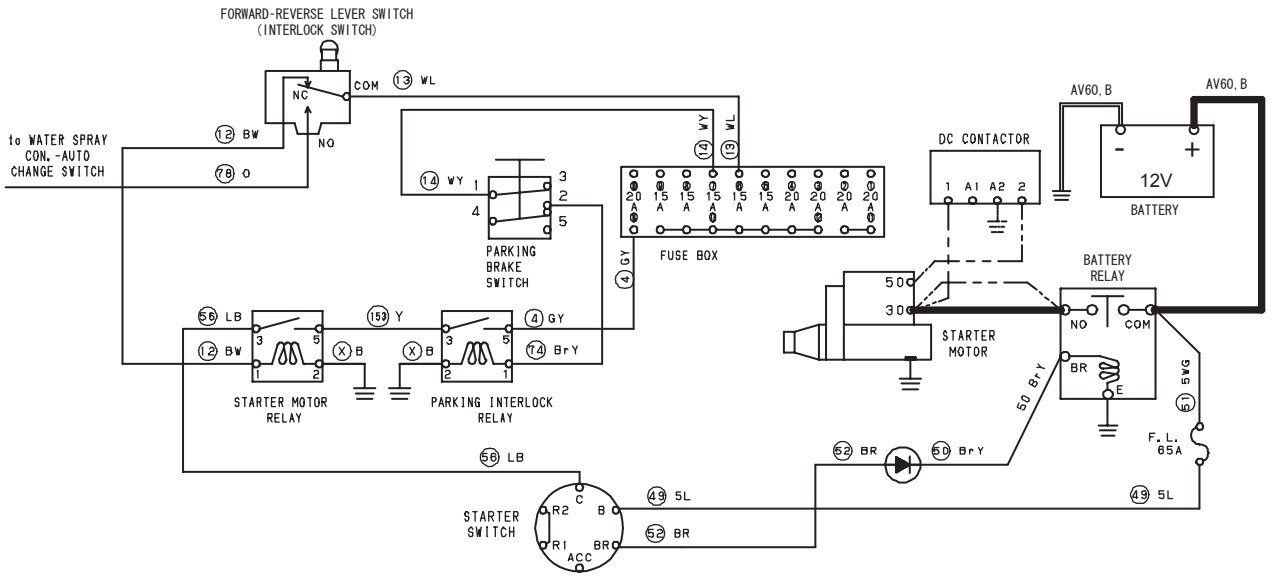

DC contactor

Circuit diagram

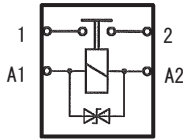

Parking interlock relay Starter motor relay

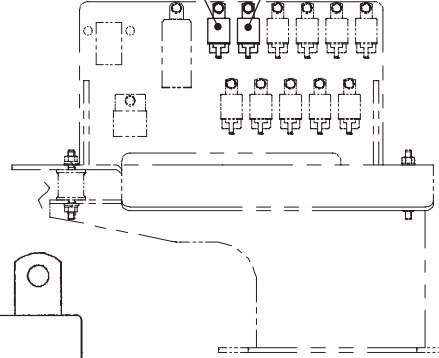

Parking interlock relay Starter motor relay

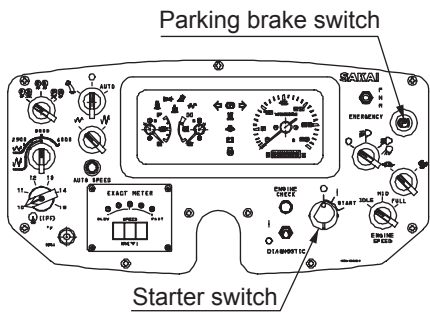

Parking brake switch

Starter switch

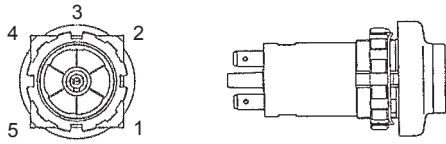

Parking brake switch

Circuit diagram

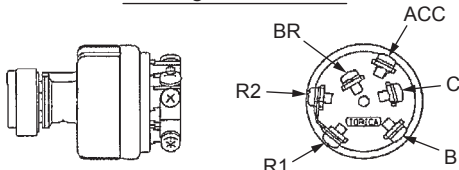
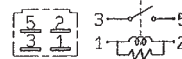

Starter switch

DC contactor Starter motor

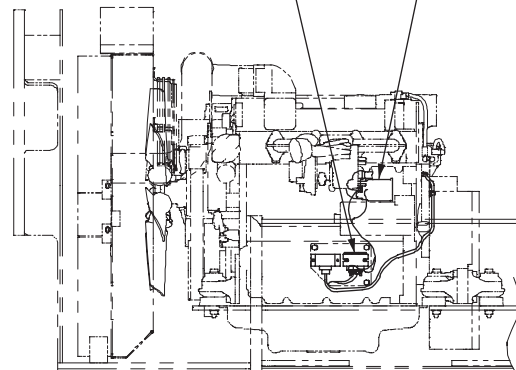

Terminal	B	R1	R2	ACC	BR	C
Key position						
HEAT	○	○	○	○	○	
OFF						
ON	○				○	
START	○	○	○	○	○	○

Starter switch connection table

2-4-1. Engine will not start (5/8)**Reference Fig. : 2-4-4**

2) When the engine check lamp is neither illuminated nor flashing

Check point	Check/Cause	Action
1. Starter Switch	<ul style="list-style-type: none"> - Check the continuity between O and O according to the starter switch connection table. The switch is OK if there is continuity between the connections O–O of all the switch positions. - If there is no continuity, the starter switch is faulty. 	Replace the starter switch.
2. Starter Motor	<ul style="list-style-type: none"> (1) When the starter switch is START, measure the voltage between the starter motor pin 30 and the chassis ground. Standard voltage: 12V or more (2) When the starter switch is START, measure the voltage between the starter motor pin 50 and the chassis ground. Standard voltage: 12V or more - If the starter motor does not run even though the above items (1) and (2) are OK, the start motor is faulty. 	Replace the starter motor.
3. Battery Relay	<ul style="list-style-type: none"> (1) When the starter switch is OFF, measure the voltage between the battery relay primary terminal and the chassis ground. Standard voltage: 12V or more (2) When the starter switch is ON, measure the voltage between the battery relay BrY wire terminal and the chassis ground. Standard voltage: 12V or more - If the above items (1) and (2) are OK and the battery relay switching click does not sound when the starter switch is turned ON, the battery relay is faulty. 	Replace the battery relay.
4. DC Contactor	<ul style="list-style-type: none"> (1) When the starter switch is ON, measure the voltage between the DC contactor pin 1 and the chassis ground. Standard voltage: 12V or more (2) When the starter switch is ON, measure the voltage between the DC contactor pin 2 and the chassis ground. Standard voltage: 12V or more (3) When the starter switch is START, measure the voltage between the DC contactor pin A1 and the chassis ground. Standard voltage: 12V or more - If the starter motor does not run even though the above items (1), (2) and (3) are OK, the DC contactor is faulty. 	Replace the DC contactor.
5. Parking Brake Switch	<ul style="list-style-type: none"> (1) When the starter switch is ON, measure the voltage between the parking brake switch pin 1 inlet WY wire and the chassis ground. Standard voltage: 12V or more (2) When the starter switch is ON, measure the voltage between the parking brake switch pin 2 inlet BrY wire and the chassis ground. Standard voltage: 12V or more - If the above item (1) is OK and the item (2) is NG, the parking brake switch is faulty. 	Replace the parking brake switch.

Fig. : 2-4-4

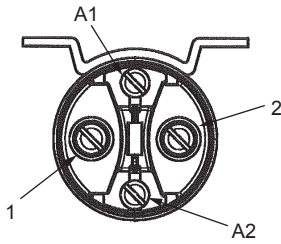
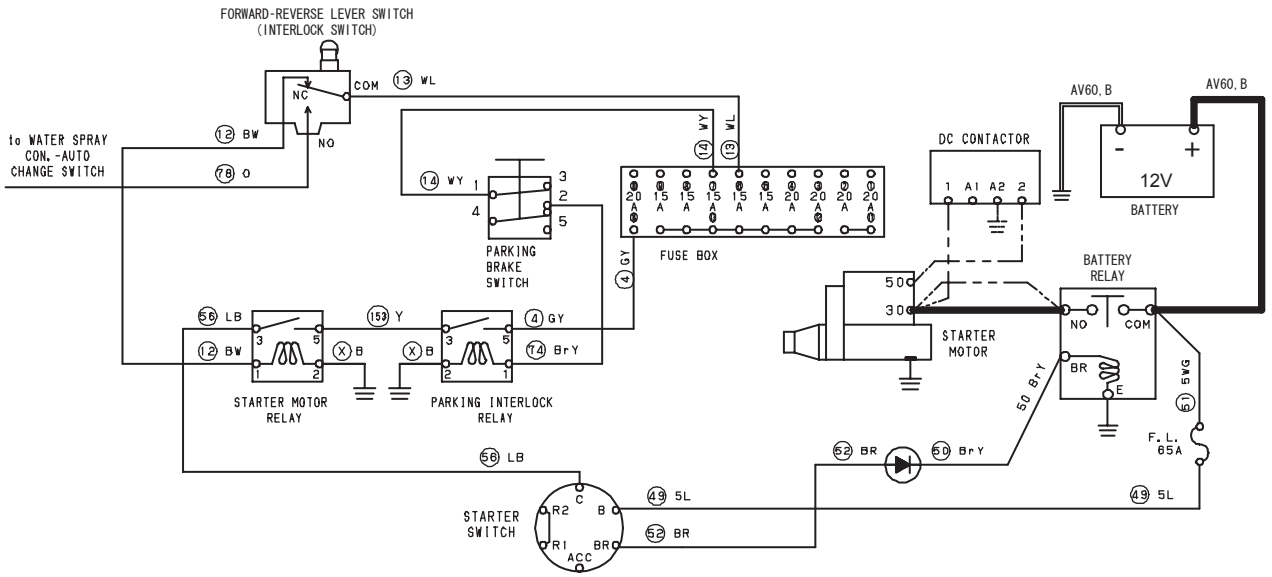

DC contactor

Circuit diagram

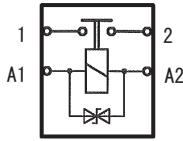

Parking interlock relay Starter motor relay

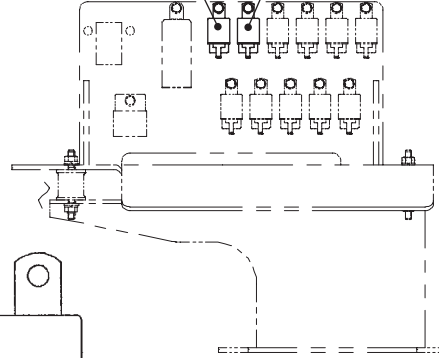

Parking interlock relay Starter motor relay

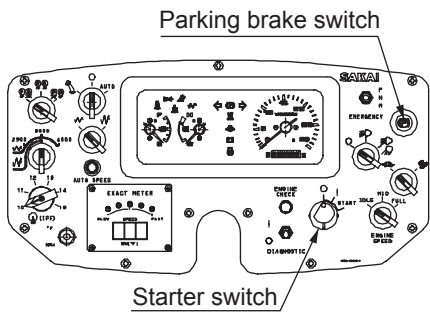

Starter switch

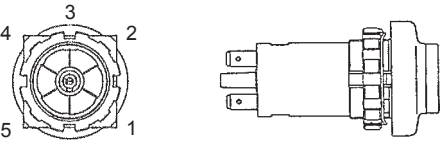

Parking brake switch

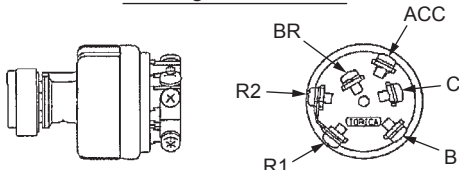

Starter switch

Circuit diagram

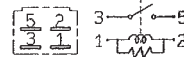

DC contactor Starter motor

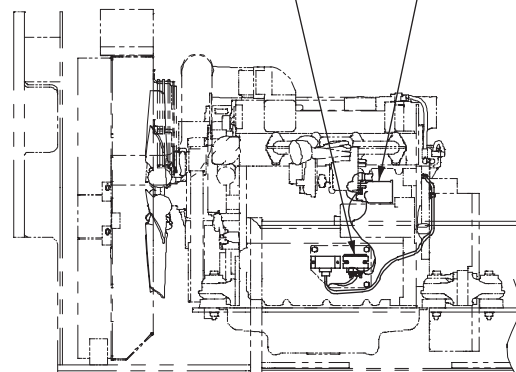

Terminal	B	R1	R2	ACC	BR	C
Key position						
HEAT	○	○	○	○	○	
OFF						
ON	○				○	
START	○	○	○	○	○	

Starter switch connection table

2-4-1. Engine will not start (6/8)**Reference Fig. : 2-4-4**

2) When the engine check lamp is neither illuminated nor flashing

Check point	Check/Cause	Action
6. Parking Interlock Relay	<p>(1) When the starter switch is ON, measure the voltage between the parking interlock relay pin 1 inlet BrY wire and the chassis ground. Standard voltage: 12V or more</p> <p>(2) When the starter switch is ON, measure the voltage between the parking interlock relay pin 5 inlet GY wire and the chassis ground. Standard voltage: 12V or more</p> <p>(3) When the starter switch is ON, measure the voltage between the parking interlock relay pin 3 inlet Y wire and the chassis ground. Standard voltage: 12V or more</p> <p>- If the above items (1) and (2) are OK and the item (3) is NG, the parking interlock relay is faulty.</p>	Replace the parking interlock relay.

Fig. : 2-4-5

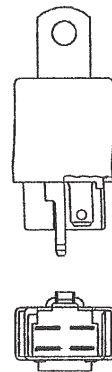
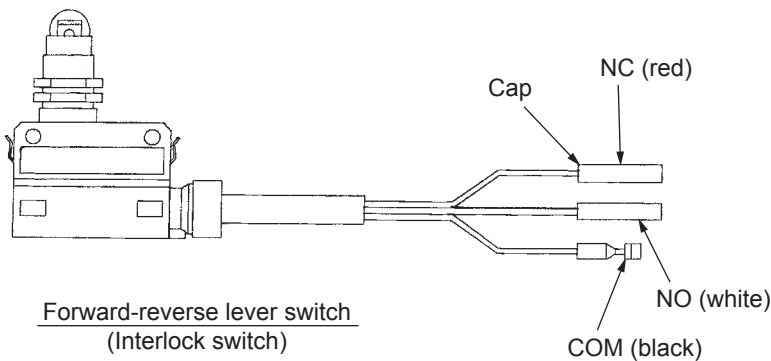
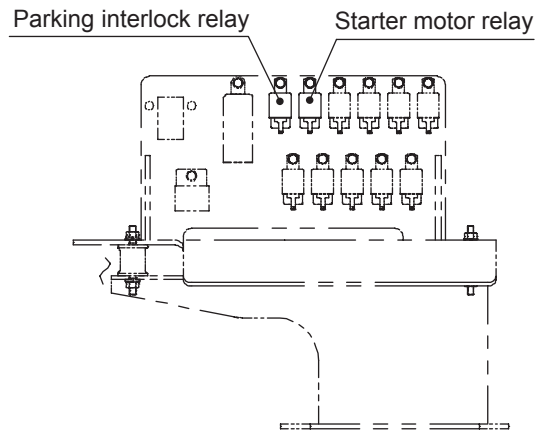
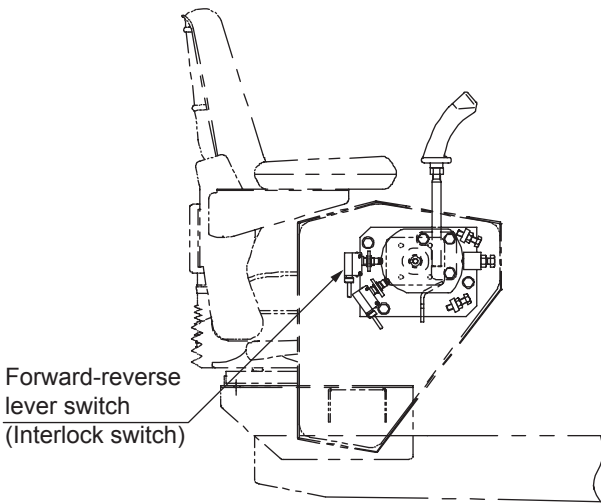
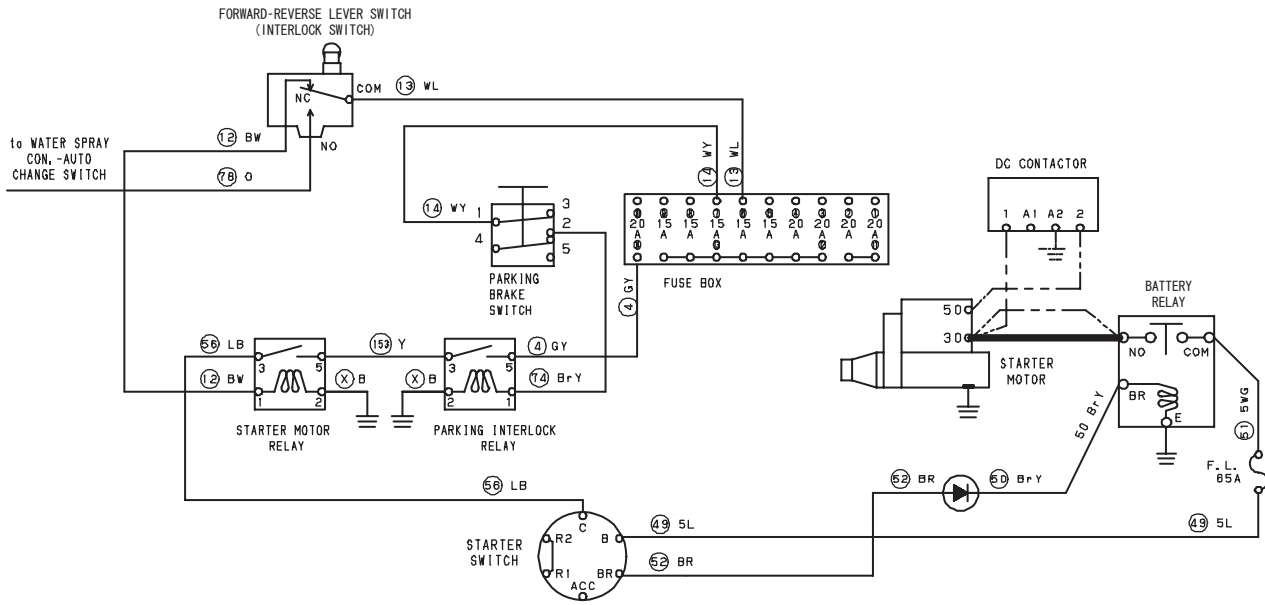

Circuit diagram

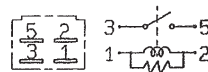

2-4-1. Engine will not start (7/8)**Reference Fig. : 2-4-5**

2) When the engine check lamp is neither illuminated nor flashing

Check point	Check/Cause	Action
7. Forward-Reverse Lever Switch (interlock switch)	<ul style="list-style-type: none"> - Check the continuity between the forward-reverse lever switch COM terminal and NC terminal with the forward-reverse lever in neutral and with the starter switch OFF. - The switch is OK if there is continuity. If there is no continuity, the forward-reverse lever switch is faulty. 	Replace the forward-reverse lever switch.
8. Starter Motor Relay	<ul style="list-style-type: none"> (1) When the starter switch is ON, measure the voltage between the starter motor relay pin 1 inlet BW wire and the chassis ground. Standard voltage: 12V or more (2) When the starter switch is ON, measure the voltage between the starter motor relay pin 5 inlet Y wire and the chassis ground. Standard voltage: 12V or more (3) When the starter switch is ON, measure the voltage between the starter motor relay pin 3 inlet LB wire and the chassis ground. Standard voltage: 12V or more - If the above items (1) and (2) are OK and the item (3) is NG, the starter motor relay is faulty. 	Replace the starter motor relay.
9. Harness Connecting Between Terminals	<ul style="list-style-type: none"> - Measure the resistance of the harness connecting between terminals. Standard resistance: 10 Ω or less - If the resistance is abnormal, the harness is faulty. 	Repair or replace the harness.

Fig. : 2-4-6

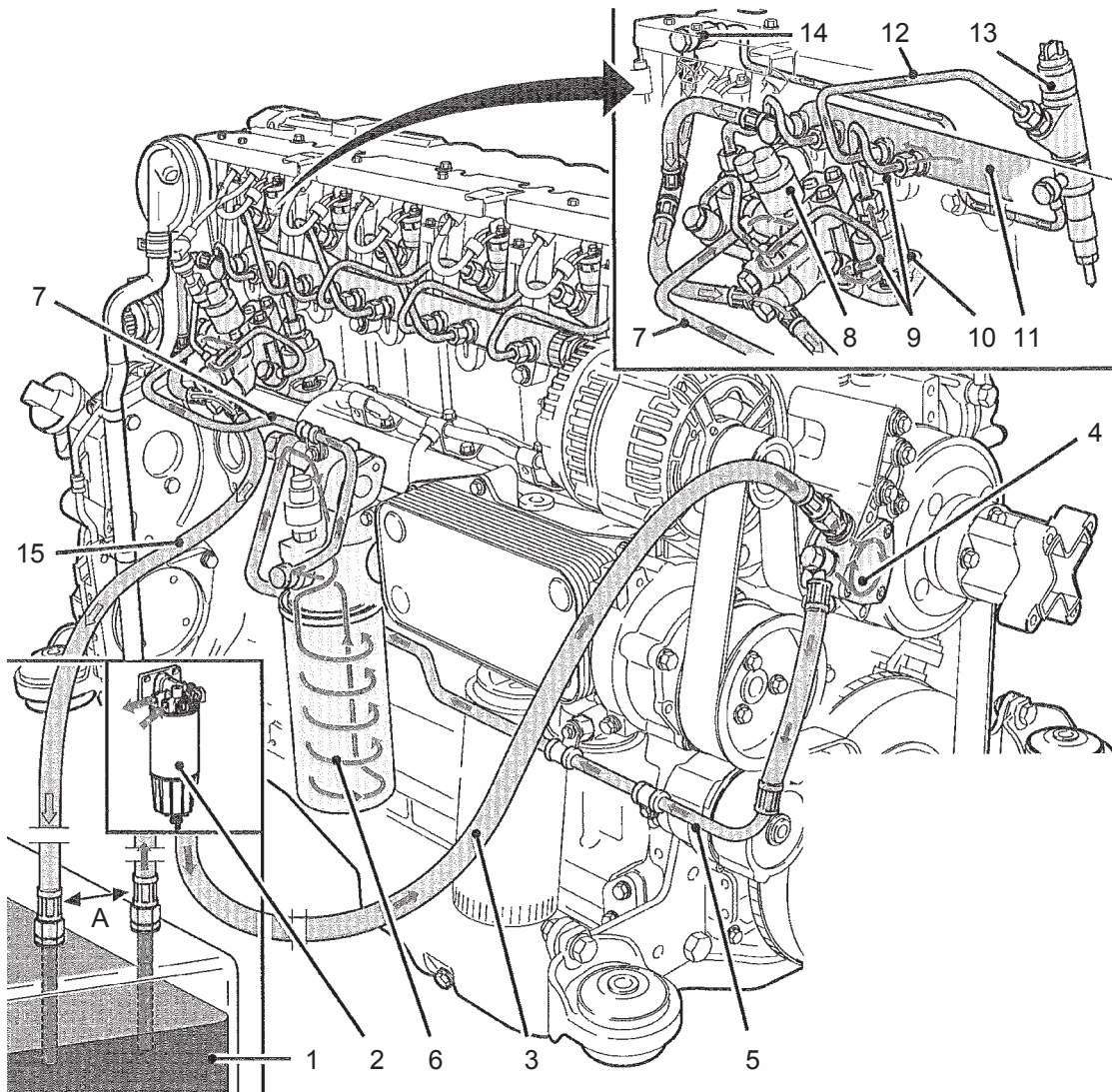

SW880-11032

Fuel schematic

- 1 Fuel container
A= minimum distance 500 mm
- 2 Fuel pre-filter with manual supply pump for filling the low-pressure area (mounted on device side)
- 3 Line to the fuel supply pump
- 4 Fuel supply pump
- 5 Line to the spin-on fuel filter
- 6 Exchangeable fuel filter
- 7 Fuel line to the control block
- 8 Control block FCU (Fuel Control Unit)
- 9 Fuel line from the control block to the high-pressure pumps and the rail
- 10 High-pressure pump
- 11 Rail
- 12 Fuel line to the injector
- 13 Injector
- 14 Fuel return line at the cylinder head
- 15 Fuel return to fuel tank

2-4-1. Engine will not start (8/8)**Reference Fig. : 2-4-6**

3) Fuel system is abnormal

Check point	Check/Cause	Action
1. Fuel Tank	- Check that the fuel tank is filled with diesel oil. - If the quantity is low, the fuel is not delivered to the fuel system.	Fill the tank with fuel.
	- Check that there is no water that has entered the fuel tank. - If water has entered the tank, the engine does not start.	Drain water from the tank.
	- Check that the quality of the diesel oil is sufficient. - If the oil does not meet the standard, the engine may fail.	Replace the fuel in the tank with an appropriate one.
2. Fuel Prefilter (with sedimenter), Fuel Filter	- Check that the water in the sedimenter is not above the upper limit. - If the amount of water exceeds the limit, the engine does not start.	Drain water.
	- Check the filter for clogging. - Insufficient supply of proper fuel due to clogging of the filter. (NOTICE) • Air bleeding should be performed whenever the filter is replaced.	- Replace the filter. - Bleed the filter.
3. Fuel Supply Pump	- Disconnect the hose connecting to the fuel supply pump and check that fuel flows out of the pump. - If fuel does not flow out of the pump, it is not delivered to the fuel system. (NOTICE) • Air bleeding should be performed whenever the fuel supply pump is replaced.	- Replace the fuel supply pump. - Bleed the pump.
4. Hoses Connecting Between Parts	- Check the hose between the fuel tank and the fuel filter for fuel leakage and clogging. - Hose failure due to deterioration (NOTICE) • Air bleeding should be performed whenever the fuel hose is replaced.	Replace the hose.

Fig. : 2-4-7

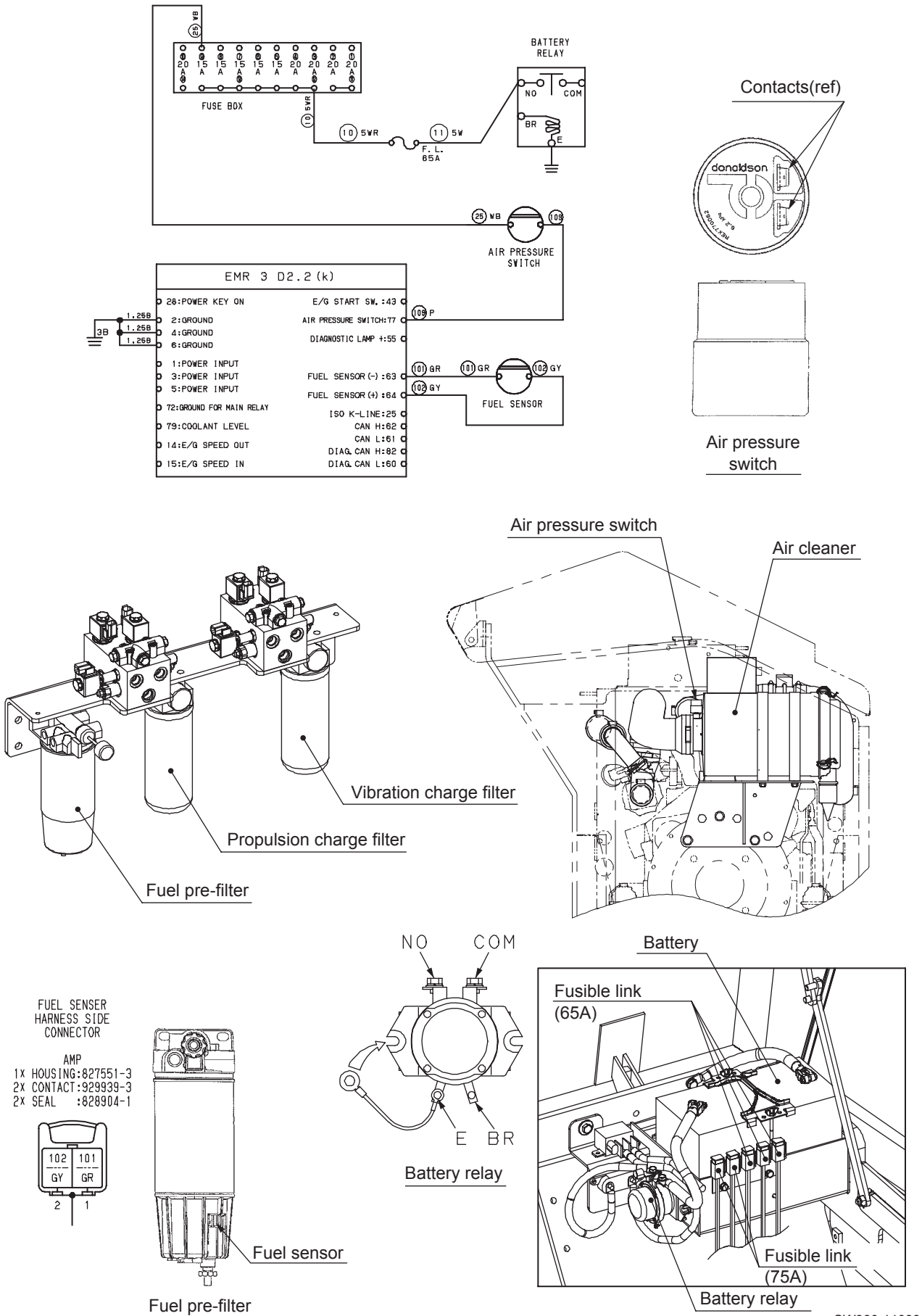

2-4-2. Insufficient output of engine or engine malfunction (1/2)**Reference Fig. : 2-4-7**

1) When the engine check lamp is illuminated or flashing

Blink code	Check point	Check/Cause	Action
1-2-8, 2-2-3 or 2-3-3	1. Connector	- Check the air pressure switch and EMR 3 connector (pin 77) for corrosion, breakage, bending and looseness. - If any abnormality is found, the connector is faulty.	Replace the connector or terminal.
	2. Harness	(1) Measure the resistance between the air pressure switch input terminal P wire and the EMR 3 connector pin 77 P wire. Standard resistance: 10 Ω or less (2) Measure the resistance between the air pressure switch input terminal WB wire and the fuse box 9 inlet WB wire. Standard resistance: 10 Ω or less (3) Measure the resistance between the fuse box 12 inlet WR wire and the battery relay terminal W wire. Standard resistance: 10 Ω or less - If the above resistance is abnormal, the harness or fusible link is faulty.	Repair or replace the harness or fusible link.
	3. Air Pressure Switch	- When the starter switch is OFF, check the continuity between the air pressure switch inlet terminals. - No continuity indicates the normal condition. If continuity is present, the air pressure switch is faulty.	Replace the air pressure switch.
	4. EMR 3	- If any of the blink codes 1-2-8, 2-2-3 and 2-3-3 flashes and no abnormality is found in the connector, harness or air pressure switch in the above inspections, the EMR 3 is faulty.	Replace the EMR 3.
2-2-8	1. Connector	- Check the fuel sensor and EMR 3 connector (pins 63 and 64) for corrosion, breakage, bending and looseness. - If any abnormality is found, the connector is faulty.	Replace the connector or terminal.
	2. Harness	(1) Measure the resistance between the fuel sensor inlet terminal GR wire and the EMR 3 connector pin 63 GR wire. Standard resistance: 10 Ω or less (2) Measure the resistance between the fuel sensor inlet terminal GY wire and the EMR 3 connector pin 64 GY wire. Standard resistance: 10 Ω or less - If the resistance is abnormal, the harness is faulty.	Repair or replace the harness.
	3. Fuel Sensor	- When the starter switch is OFF, check the continuity between the fuel sensor inlet terminals. - No continuity indicates the normal condition. If continuity is present, the fuel sensor is faulty.	Replace the fuel sensor.
	4. EMR 3	- If the blink code 2-2-8 flashes and no abnormality is found in the connector, harness and fuel sensor in the above inspections when the water in the fuel filter is below the upper limit, the EMR 3 is faulty.	Replace the EMR 3.

Fig. : 2-4-8

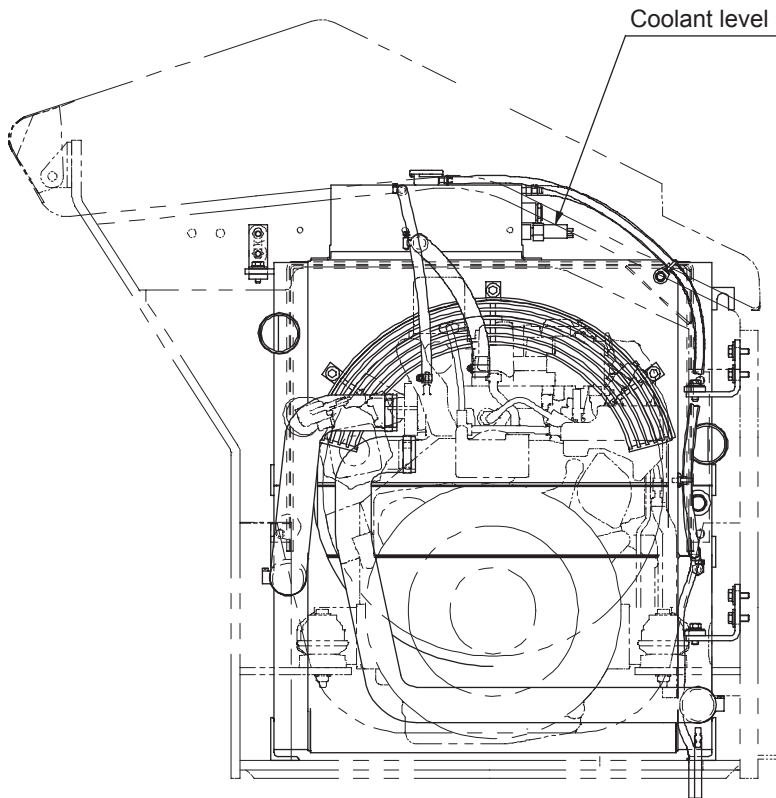
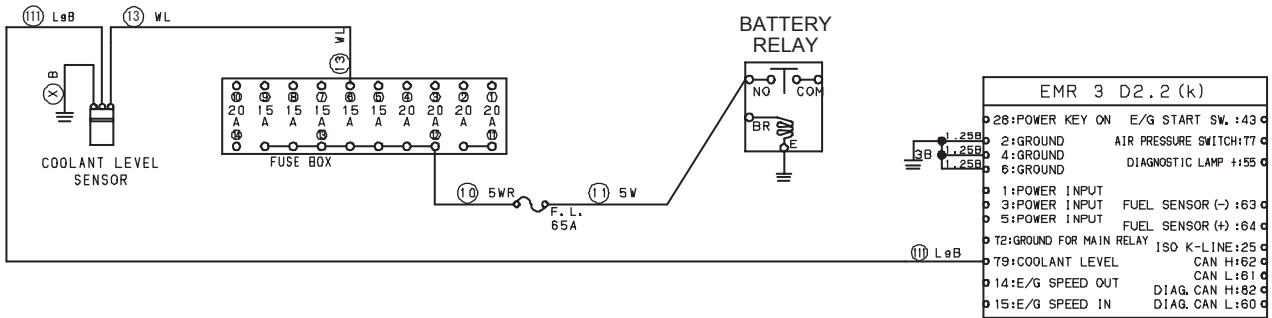

Coolant level sensor

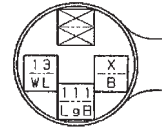

Coolant level sensor connector

• The arrangement of connector terminals shown above is that of connecting surface on the connector side.

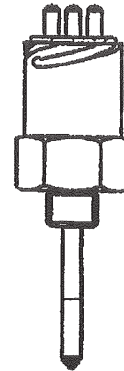

Coolant level sensor

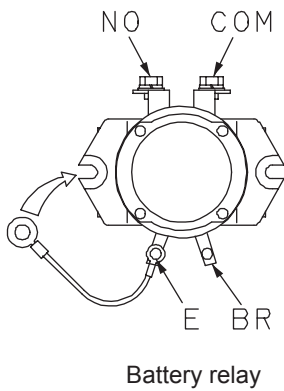

Battery relay

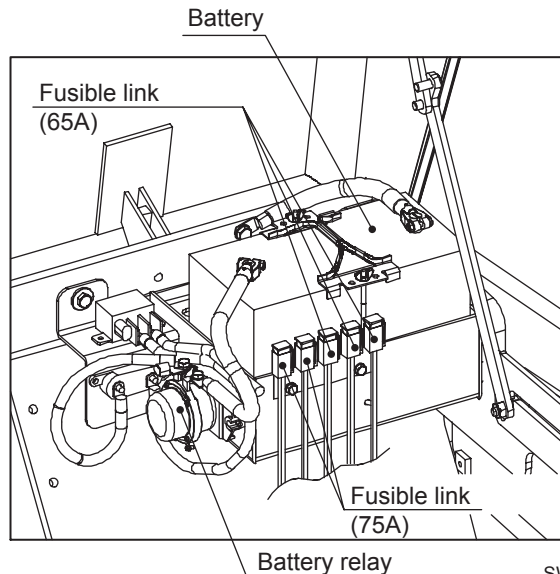

Battery

Fusible link (65A)

Fusible link (75A)

Battery relay

2-4-2. Insufficient output of engine or engine malfunction (2/2)**Reference Fig. : 2-4-8**

1) When the engine check lamp is illuminated or flashing

Blink code	Check point	Check/Cause	Action
2-3-5	1. Connector	- Check the coolant level sensor and EMR 3 connector (pin 79) for corrosion, breakage, bending and looseness. - If any abnormality is found, the connector is faulty.	Replace the connector or terminal.
	2. Harness	(1) Measure the resistance between the EMR 3 connector pin 79 LgB wire and the coolant level sensor inlet terminal LgB wire. Standard resistance: 10 Ω or less (2) Measure the resistance between the coolant level sensor inlet terminal WL wire and the fuse box 6 inlet WL wire. Standard resistance: 10 Ω or less (3) Measure the resistance between the fuse box 12 inlet WR wire and the battery relay terminal W wire. Standard resistance: 10 Ω or less - If the resistance is abnormal, the harness or fusible link is faulty.	Repair or replace the harness.
	3. Coolant Level Sensor	(1) Remove the coolant level sensor from the radiator and check the continuity between the coolant level sensor input terminal LgB and WL wires with the lower end (about 20 mm) of the sensor dipped in water. There is continuity in the normal condition. (2) Remove the coolant level sensor from the water as it was in the item (1) and check the continuity again. There is no continuity in the normal condition. - If the above item (1) or (2) is NG, the coolant level sensor is faulty.	Replace the coolant level sensor.
	4. EMR 3	- If the blink code 2-3-5 flashes and no abnormality is found in the connector, harness or coolant level sensor in the above inspections, the EMR 3 is faulty.	Replace the EMR 3.

Fig. : 2-4-9

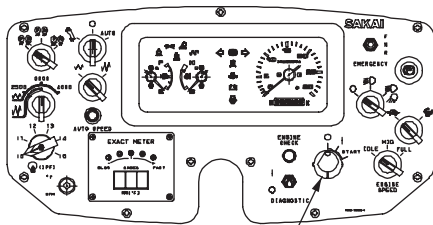
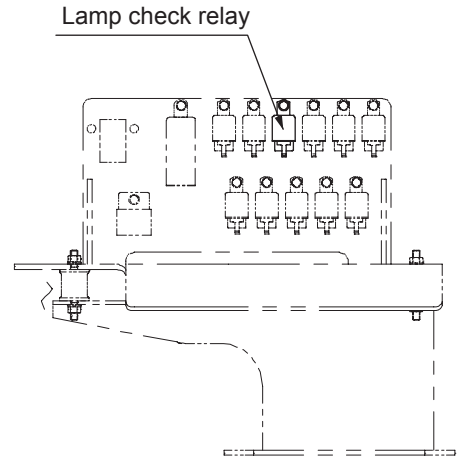
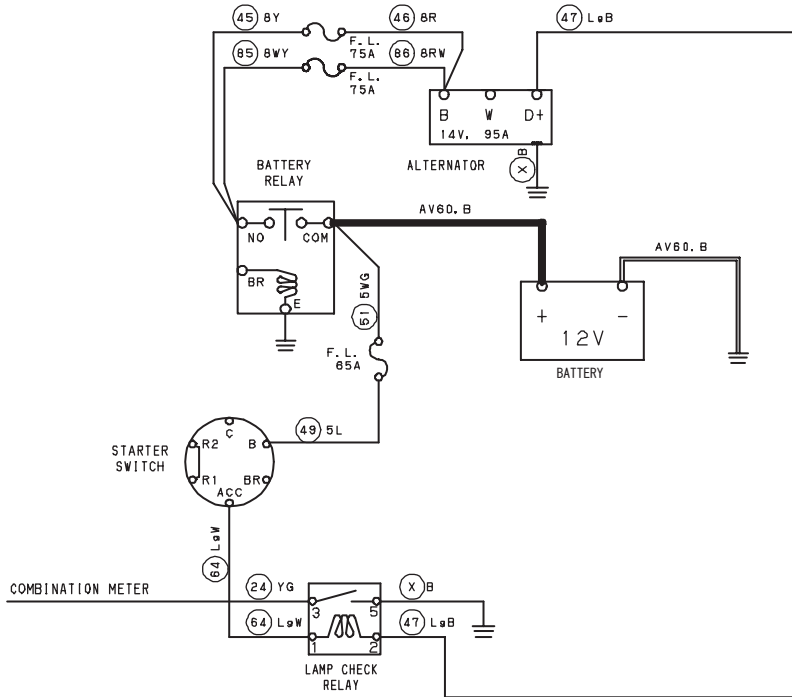

Starter switch

Terminal	B	R 1	R 2	ACC	BR	C
HEAT	○	○	○	○	○	
OFF						
ON	○					
START	○	○	○	○	○	○

Starter switch connection table

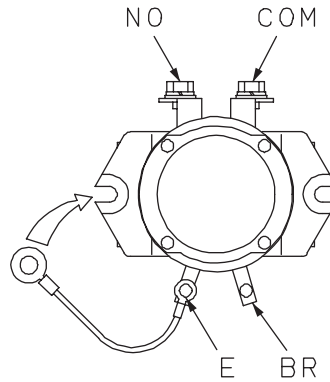

Battery relay

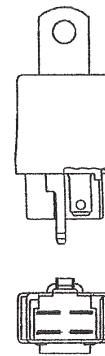

Circuit diagram

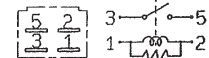

Lamp check relay

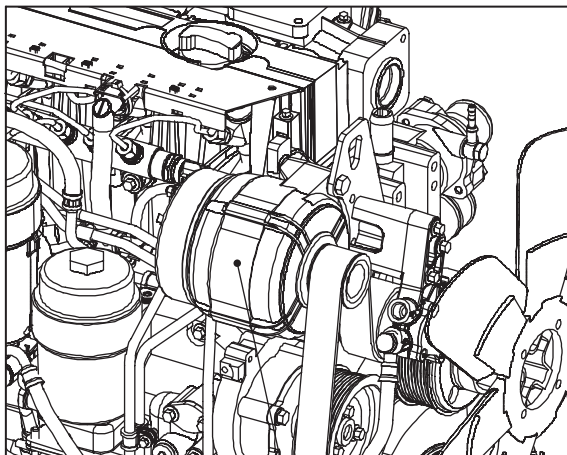

Alternator

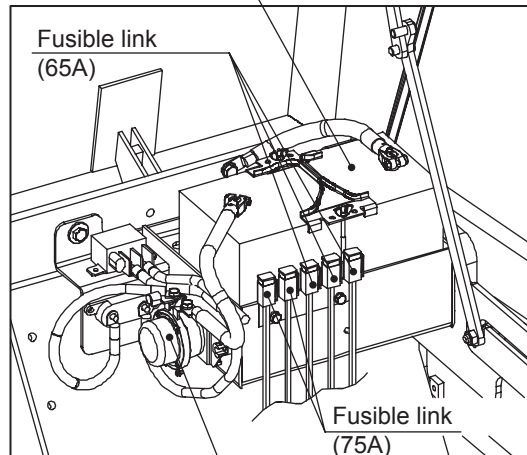

Fusible link (65A)

Fusible link (75A)

Battery relay

2-4-3. No charging

- When the start switch is ON, the charge warning lamp lights up.

Reference Fig. : 2-4-9

1) When the engine check lamp is neither illuminated nor flashing

Check point	Check/Cause	Action
1. Alternator	<p>(1) After turning the starter switch to the START position, measure the voltage between the alternator terminal B and the chassis ground. Standard voltage: 12V or more at middle or higher engine speeds</p> <p>(2) When the starter switch is ON, measure the voltage between the alternator terminal D+ and the chassis ground. Standard voltage: 12V or more</p> <p>- If the item (1) is NG, the alternator is faulty. - If the above item (1) is OK and the item (2) is NG, the regulator is faulty.</p>	Replace the alternator or regulator.
2. Lamp Check Relay	<p>(1) When the starter switch is ON, measure the voltage between the lamp check relay pin 1 inlet LgW wire and the chassis ground. Standard voltage: 12V or more</p> <p>(2) When the starter switch is ON, measure the voltage between the lamp check relay pin 2 inlet LgB wire and the chassis ground. Standard voltage: 12V or more</p> <p>(3) When the starter switch is ON, measure the voltage between the lamp check relay pin 5 inlet B wire and the chassis ground. Standard voltage: 12V or more</p> <p>- If the above items (1) and (2) are OK and the item (3) is NG, the lamp check relay is faulty.</p>	Replace the lamp check relay.
3. Harness Connecting Between Terminals	<p>- Measure the resistance of the harness connecting between terminals. Standard resistance: 10 Ω or less</p> <p>- If the resistance is abnormal, the harness or fusible link is faulty.</p>	Repair or replace the harness or fusible link.

Fig. : 2-4-10

EMR CONNECTOR																			
1	2	3	4	5	6	7	8	9	10	11	12	13	14	15	16	17	18	19	20
94	X	94	X	94	X	97	*	*	*	*	*	97	BrR	RW	*	*	*	*	*
21	22	23	24	25	26	27	28	29	30	31	32	33	34	35	36	37	38	39	40
*	*	*	*	104	*	*	52	*	*	*	*	*	*	*	*	*	*	*	*
41	42	43	44	45	46	47	48	49	50	51	52	53	54	55	56	57	58	59	60
*	*	30	*	*	*	*	*	*	*	*	*	*	103	*	*	*	*	108	*
61	62	63	64	65	66	67	68	69	70	71	72	73	74	75	76	77	78	79	80
106	105	101	102	*	*	*	*	*	*	95	*	*	*	*	109	*	111	*	*
Ry	Rb	Gr	Gy	*	*	*	*	*	*	Br	*	*	*	*	P	*	LgB	*	*
81	82	83	84	85	86	87	88	89	90	91	92	93	94						
*	*	107	*	*	*	*	*	*	*	*	*	*	*						
*	*	Yb	*	*	*	*	*	*	*	*	*	*	*						

• The arrangement of connector terminals shown above is that of connecting surface on the connector side.
 • Terminals marked with asterisks are not in use.

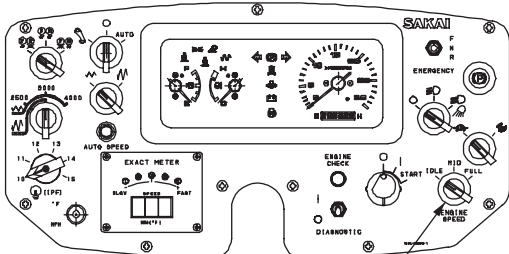
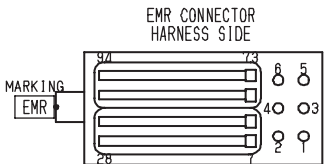
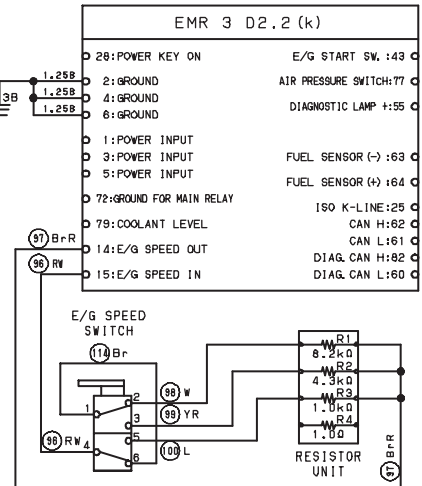

Engine speed switch

Terminal number

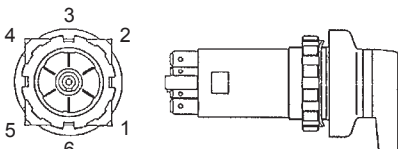

Engine speed switch

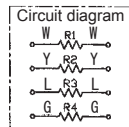
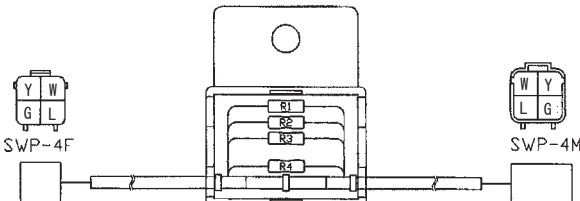
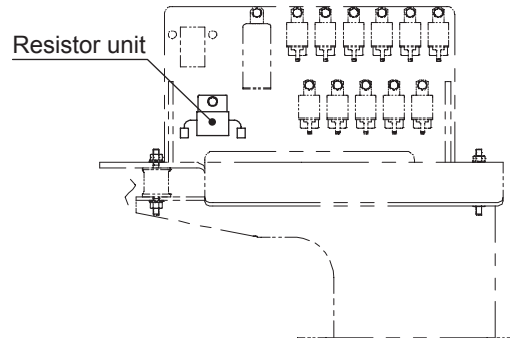

Resistor unit

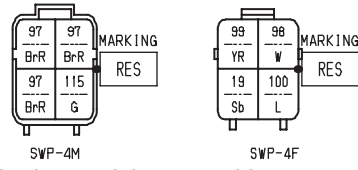
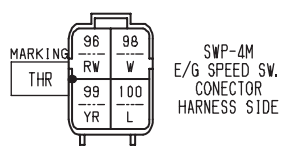

Resistor unit harness side connector

• The arrangement of connector terminals shown above is that of connecting surface on the connector side.

• The arrangement of connector terminals shown above is that of connecting surfaces on the connector side.

2-4-4. Engine speed cannot be switched

Reference Fig. : 2-4-10

1) When the engine check lamp is illuminated or flashing

Blink code	Check point	Check/Cause	Action
1-4-3	1. Connector	<ul style="list-style-type: none"> - Check the engine speed switch, resistor unit and EMR 3 connector (pins 14 and 15) for corrosion, breakage, bending and looseness. - If any abnormality is found, the connector is faulty. 	Replace the connector or terminal.
	2. Harness	<ul style="list-style-type: none"> (1) Measure the resistance between the EMR 3 connector pin 14 BrR wire and the resistor unit terminals three BrR wires. Standard resistance: 10 Ω or less (2) Measure the resistance between the resistor unit terminal W wire and the engine speed switch pin 2 W wire. Standard resistance: 10 Ω or less (3) Measure the resistance between the resistor unit terminal YR wire and the engine speed switch pin 3 YR wire. Standard resistance: 10 Ω or less (4) Measure the resistance between the resistor unit terminal L wire and the engine speed switch pin 5 L wire. Standard resistance: 10 Ω or less (5) Measure the resistance between the engine speed switch pin 6 Br wire and the engine speed switch pin 1 Br wire. Standard resistance: 10 Ω or less (6) Measure the resistance between the engine speed switch pin 4 RW wire and the EMR 3 connector pin 15 RW wire. Standard resistance: 10 Ω or less <ul style="list-style-type: none"> - If the resistance is abnormal, the harness is faulty. 	Repair or replace the harness.
	3. Engine Speed Switch	<ul style="list-style-type: none"> (1) Disconnect the engine speed switch terminal wires 1 through 6. When the engine speed switch is in the IDLE position, check the continuity between the engine speed switch pins 1 and 2 and between 4 and 6. There is continuity in the normal condition. (2) When the engine speed switch is in the MID position, check the continuity between the engine speed switch pins 1 and 3 and between 4 and 6. There is continuity in the normal condition. (3) When the engine speed switch is in the FULL position, check the continuity between the engine speed switch pins 1 and 3 and between 4 and 5. There is continuity in the normal condition. <ul style="list-style-type: none"> - If the above item (1), (2) or (3) is NG, the engine speed switch is faulty. 	Replace the engine speed switch.
	4. Resistor Unit	<ul style="list-style-type: none"> (1) Remove the 4P connector at both ends of the resistor unit and measure the resistance between the resistor unit terminal W wire and the BrR wire (R1). Standard resistance: 8.2 kΩ (2) Measure the resistance between the resistor unit terminal YR wire and the BrR wire (R2). Standard resistance: 4.3 kΩ (3) Measure the resistance between the resistor unit terminal L wire and the BrR wire (R3). Standard resistance: 1.0 kΩ <ul style="list-style-type: none"> - If the above item (1), (2) or (3) is NG, the resistor unit is faulty. 	Replace the resistor unit.
	5. EMR 3	<ul style="list-style-type: none"> - If the blink code 1-4-3 flashes and no abnormality is found in the connector, harness, engine speed switch and resistor unit in the above inspections, the EMR 3 is faulty. 	Replace the EMR 3.

Fig. : 2-4-11

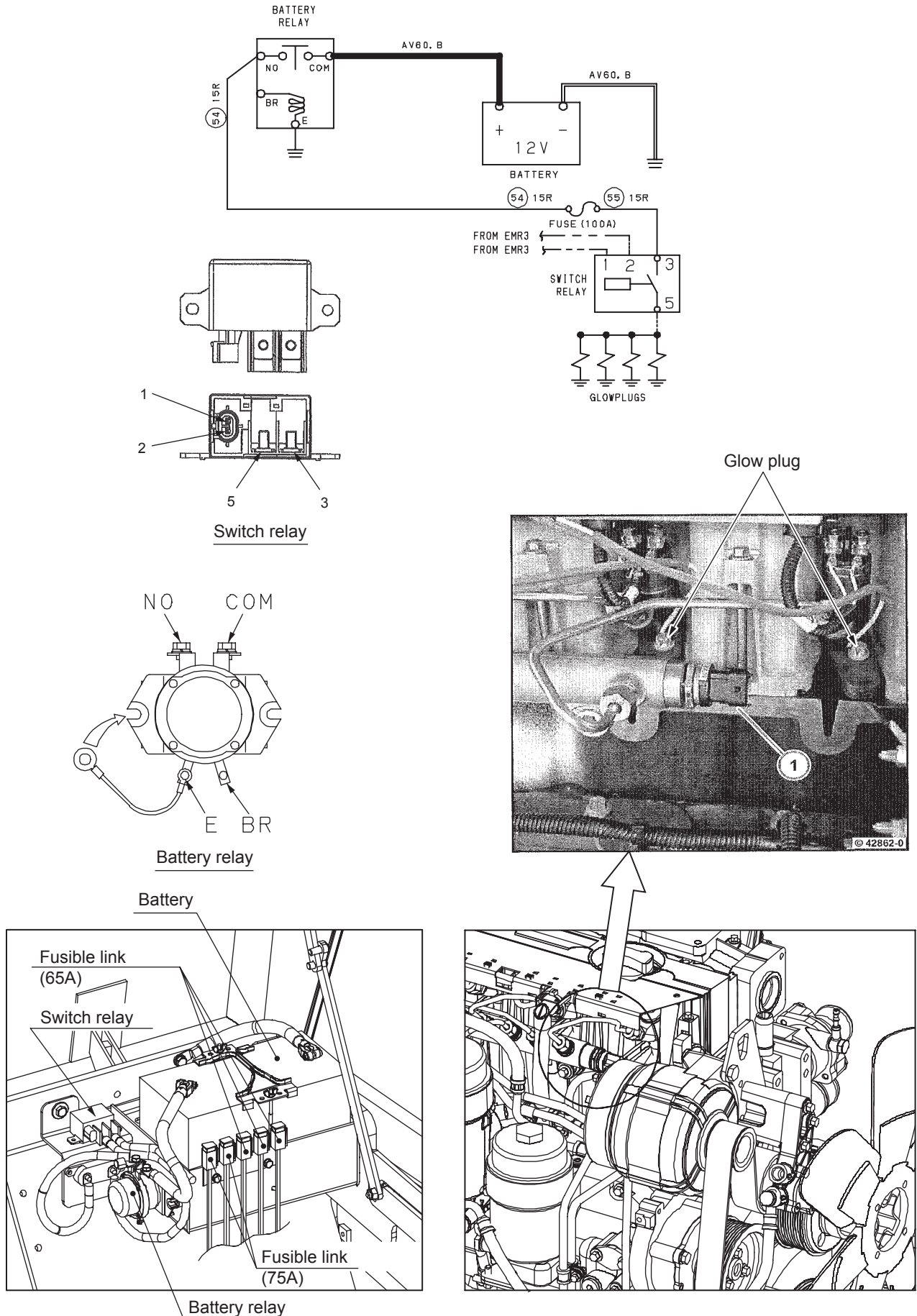

2-4-5. Glow plug is not heated (Engine starting performance is bad)**Reference Fig. : 2-4-11**

1) When the engine check lamp is illuminated or flashing.

Blink code	Check point	Check/Cause	Action
2-6-3	1. Connector	- Check the glow plug, switch relay and EMR 3 connector for corrosion, breakage, bending and looseness. - If any abnormality is found, the connector is faulty.	Replace the connector or terminal.
	2. Harness	(1) Measure the resistance between the battery relay terminal R wire and the switch relay terminal R wire. Standard resistance: 10 Ω or less (2) Measure the resistance between the switch relay terminal wire (connected to the glow plug) and each glow plug inlet wire. Standard resistance: 10 Ω or less - If the resistance is abnormal, the harness is faulty.	Repair or replace the harness.
	3. Glow Plug	- When the starter switch is START, measure the voltage between the glow plug inlet terminal and the chassis ground. Standard voltage: 12V or more - If the voltage is normal, the glow plug is faulty.	Replace the glow plug.
	4. Switch Relay or EMR 3	(1) When the starter switch is START, measure the voltage between the switch relay terminal R wire and the chassis ground. Standard voltage: 12V or more (2) When the starter switch is START, measure the voltage between the switch relay terminal (connected to the glow plug) and the chassis ground. Standard voltage: 12V or more - If the above item (1) is OK and the item (2) is NG, the switch relay or EMR 3 is faulty.	Replace the switch relay or EMR 3.

Fig. : 2-4-12

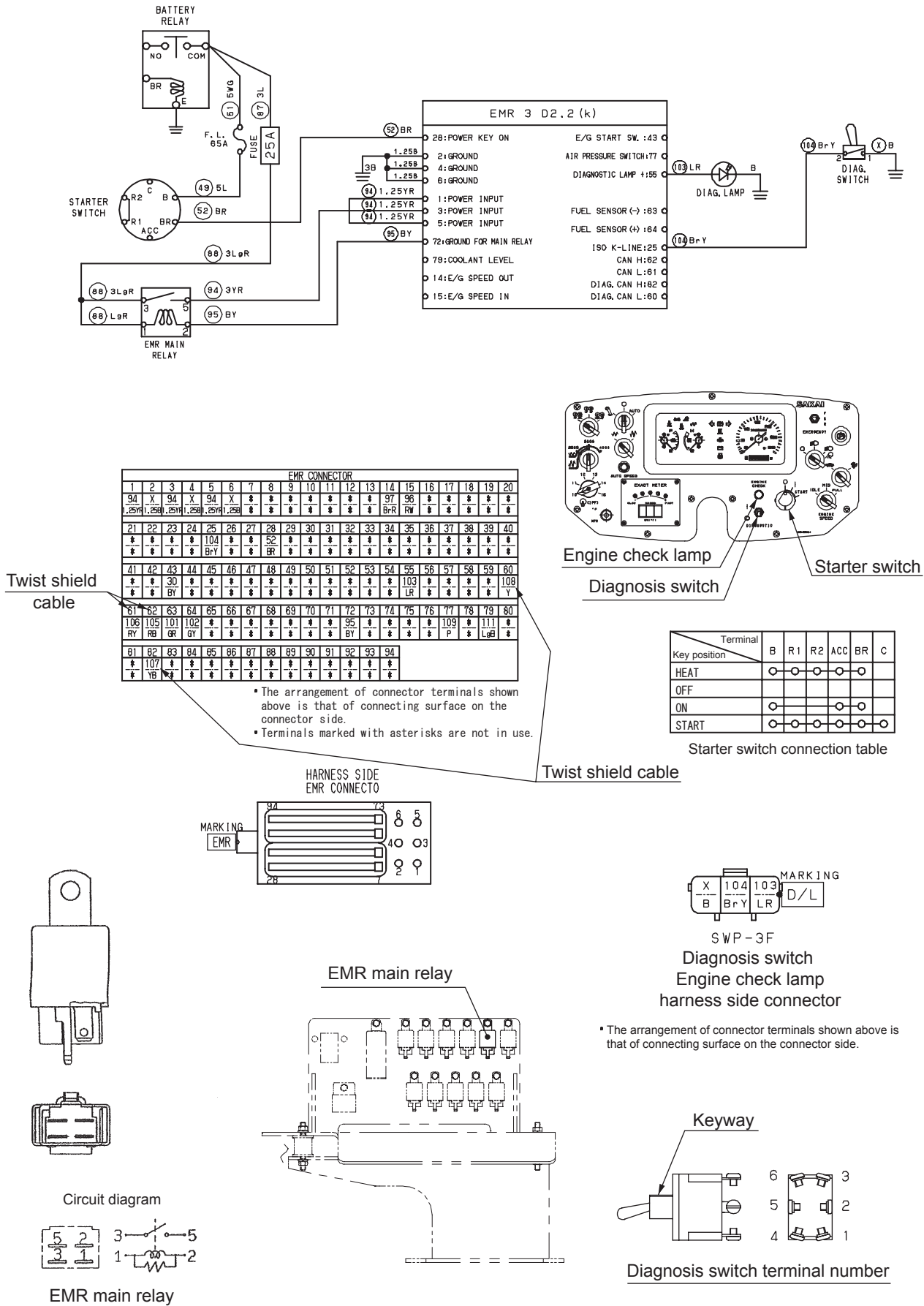

2-4-6. Engine check lamp does not illuminate**Reference Fig. : 2-4-12**

Check point	Check/Cause	Action
1. Diagnosis Switch	<ul style="list-style-type: none"> - When the starter switch is OFF and the diagnosis switch is ON, check the continuity between the diagnosis switch pins 1 and 2. The switch is OK if there is continuity. - If there is no continuity, the diagnosis switch is faulty. 	Replace the diagnosis switch.
2. Engine Check Lamp	<ul style="list-style-type: none"> - When the starter switch is ON, measure the voltage between the engine check lamp terminal LR wire and the chassis ground. Standard voltage: 12V or more - If the voltage is normal, engine check lamp is faulty. 	Replace the engine check lamp.
3. EMR 3	<ul style="list-style-type: none"> (1) Check the EMR 3 connector (pins 25 and 55) for corrosion, breakage, bending and looseness. (2) When the starter switch is ON, check that the voltage between the EMR 3 connector pins 1, 3 and 5 YR wires and pins 2, 4 and 6 B wires and between the EMR 3 connector pin 28 BR wire and pins 2, 4 and 6 B wires are in the standard range. Standard voltage: 12V or more - If the above items (1) and (2) are OK, the EMR 3 is faulty. 	Replace the EMR 3.
4. Harness Connecting Between Terminals	<ul style="list-style-type: none"> - Measure the resistance of the harness connecting between terminals. Standard resistance: 10 Ω or less - If the resistance above is abnormal, the harness is faulty. 	Repair or replace the harness.

Fig. : 2-4-13

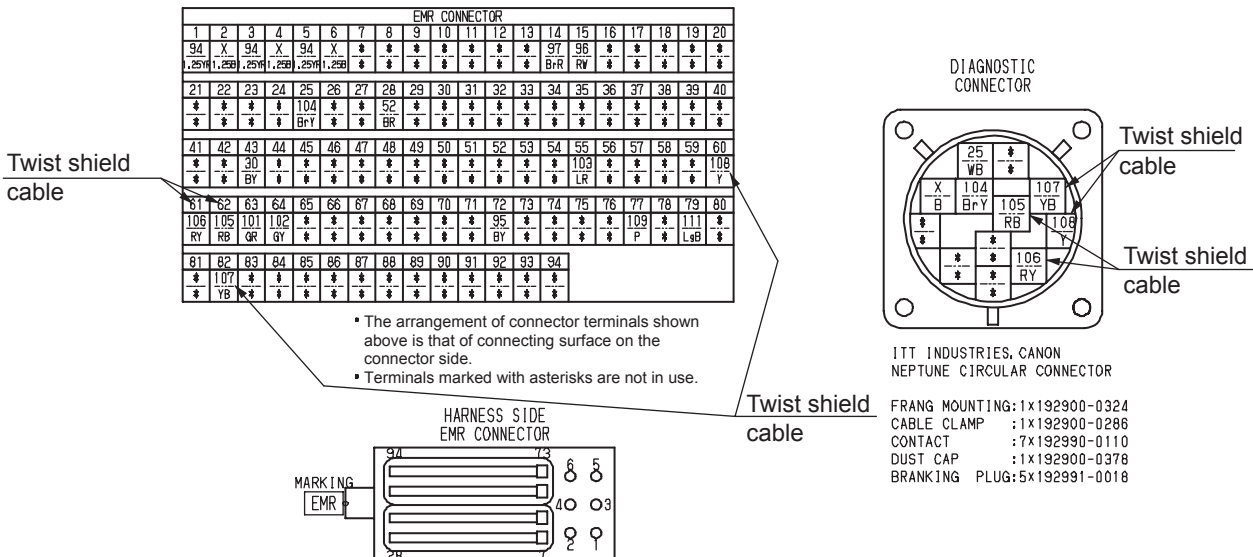
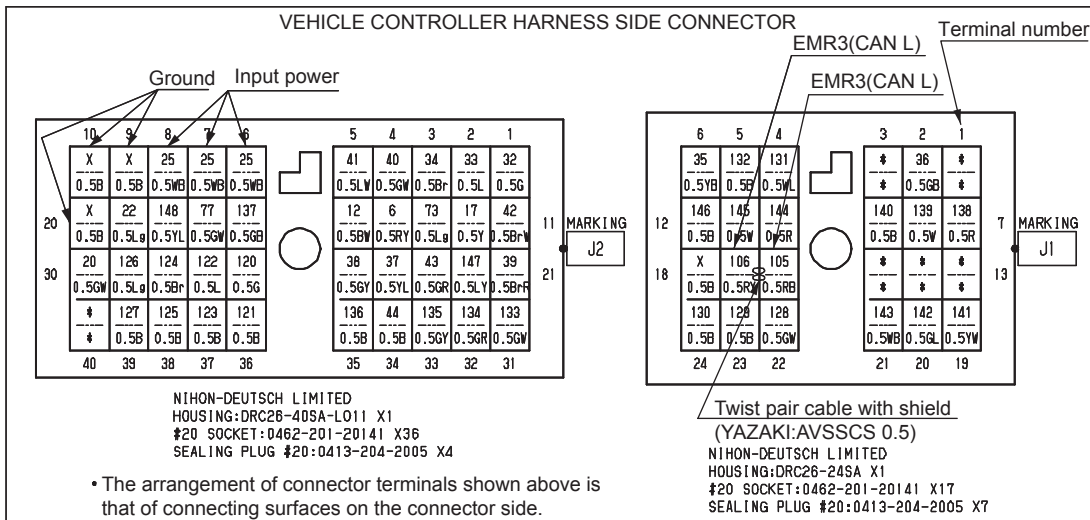
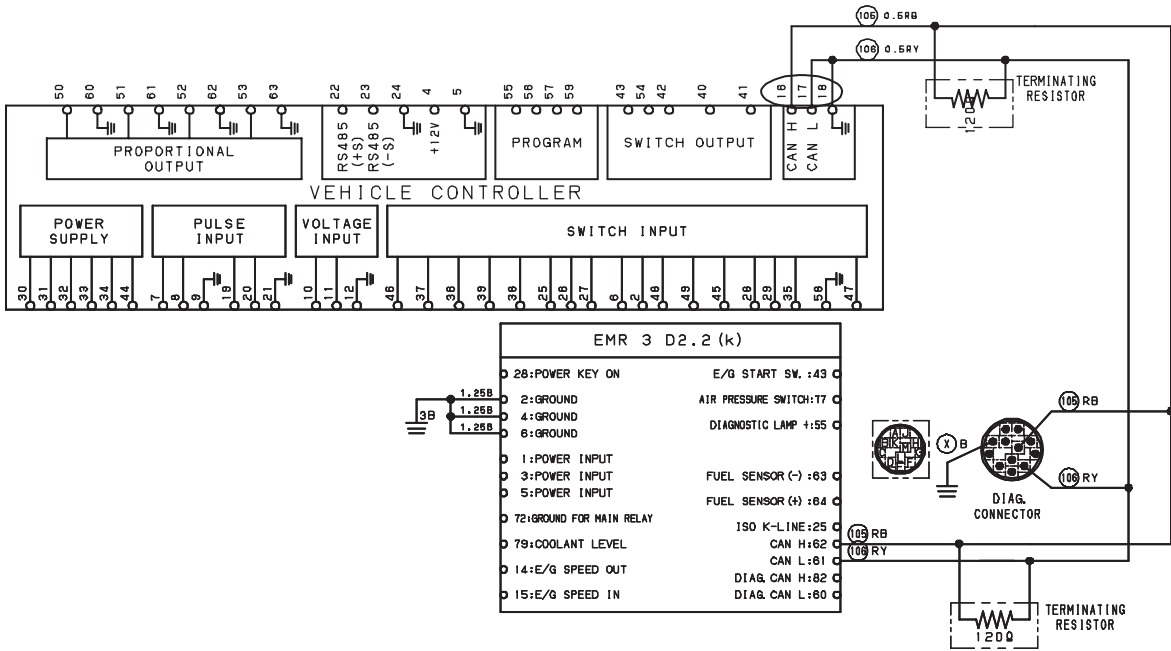

2-4-7. CAN communication is abnormal

Reference Fig. : 2-4-13

1) When the engine check lamp is illuminated or flashing

Blink code	Check point	Check/Cause	Action
1-1-1, 1-1-2, 1-1-5, 1-1-6, 1-1-8, 1-1-9, 2-7-1, 3-3-3, 3-3-7, 5-2-6 or 5-2-7	1. Connector	<ul style="list-style-type: none"> - Check the vehicle controller connector (pins 16, 17 and 18) and EMR 3 connector (terminals 61 and 62) for corrosion, breakage, bending and looseness. - If any abnormality is found, the connector is faulty. <p>(NOTICE)</p> <ul style="list-style-type: none"> • Since shielded twisted wires are used for CAN communication between the vehicle controller and the EMR 3, repair is not approved. Be sure to replace them. 	Replace the connector harness assembly.
	2. Harness	<ul style="list-style-type: none"> (1) Measure the resistance between the diagnosis connector terminal RB wire and the RY wire. Standard resistance: $60 \pm 5 \Omega$ (2) Measure the resistance between the EMR 3 pin 62 RB wire and the vehicle controller pin 16 RB wire. Standard resistance: 10Ω or less (3) Measure the resistance between the EMR 3 pin 61 RY wire and the vehicle controller pin 17 RY wire. Standard resistance: 10Ω or less <ul style="list-style-type: none"> - If the resistance measured in the item (1) is NG, the harness or terminator is faulty. - If the resistance measured in the item (2) or (3) is NG, the harness is faulty. <p>(NOTICE)</p> <ul style="list-style-type: none"> • Since shielded twisted wires are used for CAN communication between the vehicle controller and the EMR 3, repair is not approved. Be sure to replace them. 	Replace the terminator or connector harness assembly.
	3. EMR 3	<ul style="list-style-type: none"> - Faulty CAN communication <p>Note: EMR 3 for transmission is faulty.</p>	Replace the EMR 3.

(NOTICE)

- **If the faulty condition is not resolved after performing the engine troubleshooting listed above, please contact SAKAI HEAVY INDUSTRIES, LTD.**

Fig. : 2-5-1

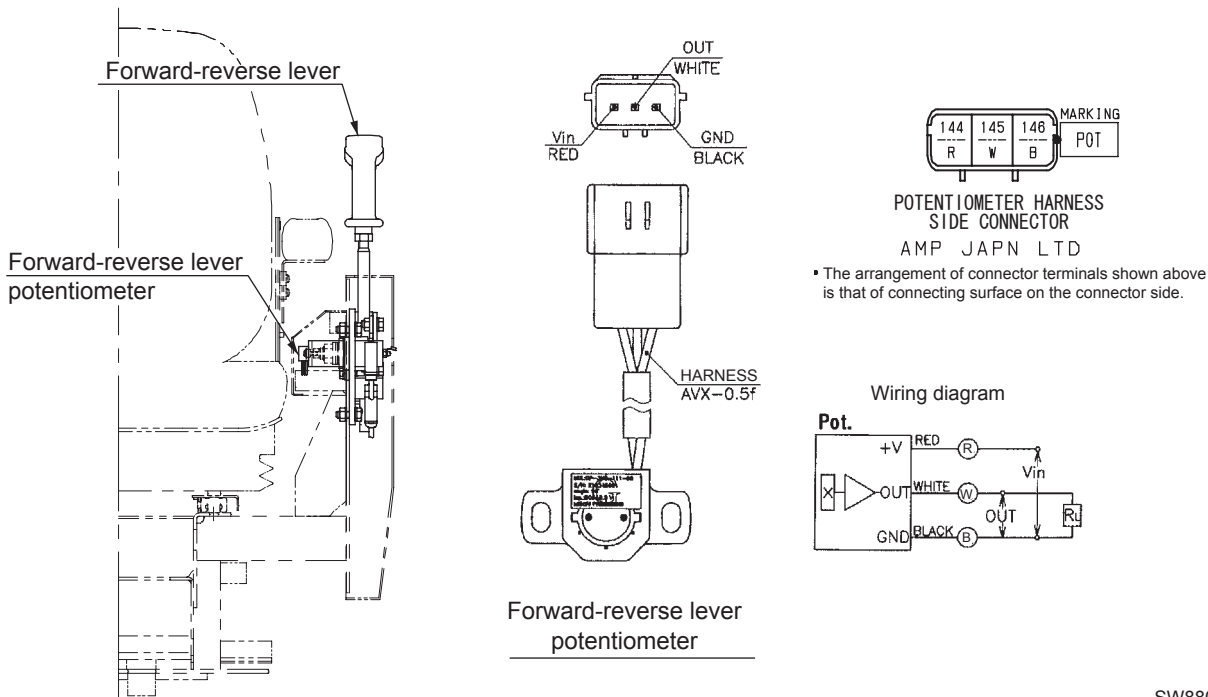
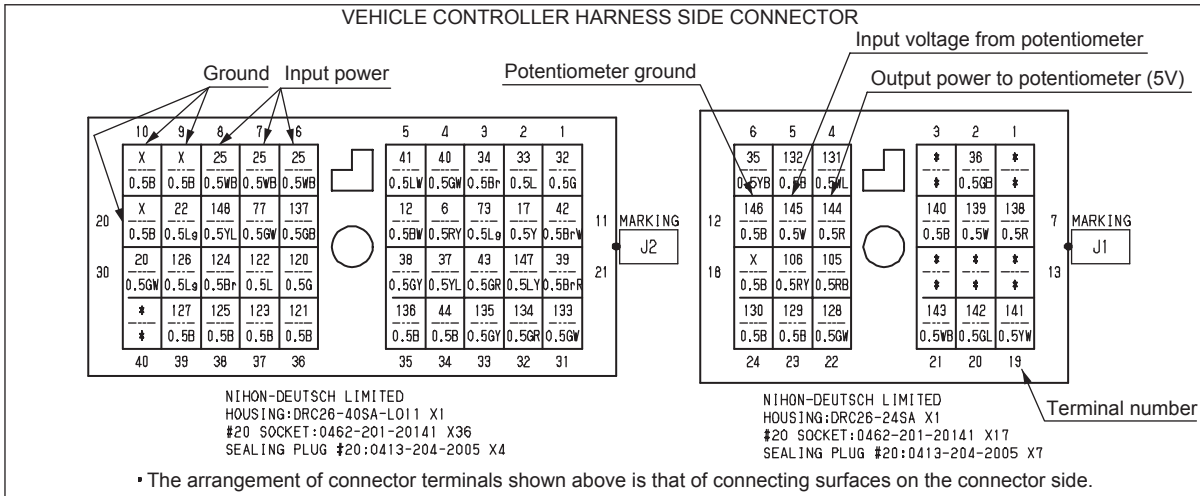
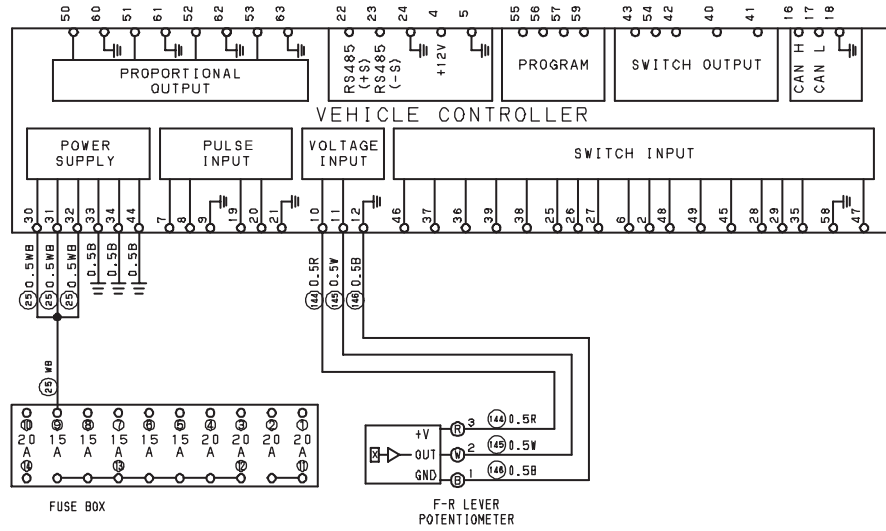

2-5. Propulsion

Check the following items before troubleshooting.

- No fuse has been blown and power is applied up to the fuses.
- When measuring voltage without disconnecting connectors, refer to the description of voltage measurement methods (P.11-006).
- Check any ground circuit which belongs to the components to be checked.

2-5-1. Vehicle moves neither forward nor backward (1/5)

- Check whether the display shows any error code.
- The parking brake switch is OFF (brake OFF).
- The foot brake switch is ON (brake OFF).

Reference Fig. : 2-5-1

1) When the display shows any error code

Error code	Check point	Check/Cause	Action
E 01 or E 02	1. Connector	- Check the potentiometer connector and vehicle controller connector (pins 10, 11 and 12) for corrosion, breakage, bending and looseness. - If any abnormality is found, the connector is faulty.	Replace the connector or terminal.
	2. Harness	- Measure the resistance between the potentiometer connector terminal R, W and B wires and the vehicle controller connector pins 10 (R wire), 11 (W wire) and 12 (B wire). Standard resistance: 10 Ω or less - If the resistance is abnormal, the harness is faulty.	Repair or replace the harness.
	3. Potentiometer	(1) When the starter switch is ON, measure the voltage between the potentiometer input terminal R wire and the potentiometer ground terminal B wire. Standard voltage: 5 \pm 0.5V (2) When the starter switch is ON, measure the voltage between the potentiometer output terminal W wire and the potentiometer ground terminal B wire. ① When the forward-reverse lever is in neutral position Standard voltage: 2.5V ② When the forward-reverse lever is in the full forward position Standard voltage: 3.6V – 4V ③ When the forward-reverse lever is in the full reverse position Standard voltage: 1V – 1.4V - If the item (1) is OK and any of the measurements in the item (2) is NG, the potentiometer is faulty.	Replace the potentiometer.
	4. Vehicle Controller	(1) When the starter switch is ON, measure the voltage between the vehicle controller input power supply pins 30, 31 and 32 and the ground pins 33, 34 and 44. Standard voltage: 12V or more (2) When the starter switch is ON, measure the voltage between the vehicle controller pins 10 (positive side) and 12 (ground side). Standard voltage: 5 \pm 0.5V - If the item (1) is OK and the item (2) is NG, the vehicle controller is faulty.	Replace the vehicle controller.

Fig. : 2-5-2

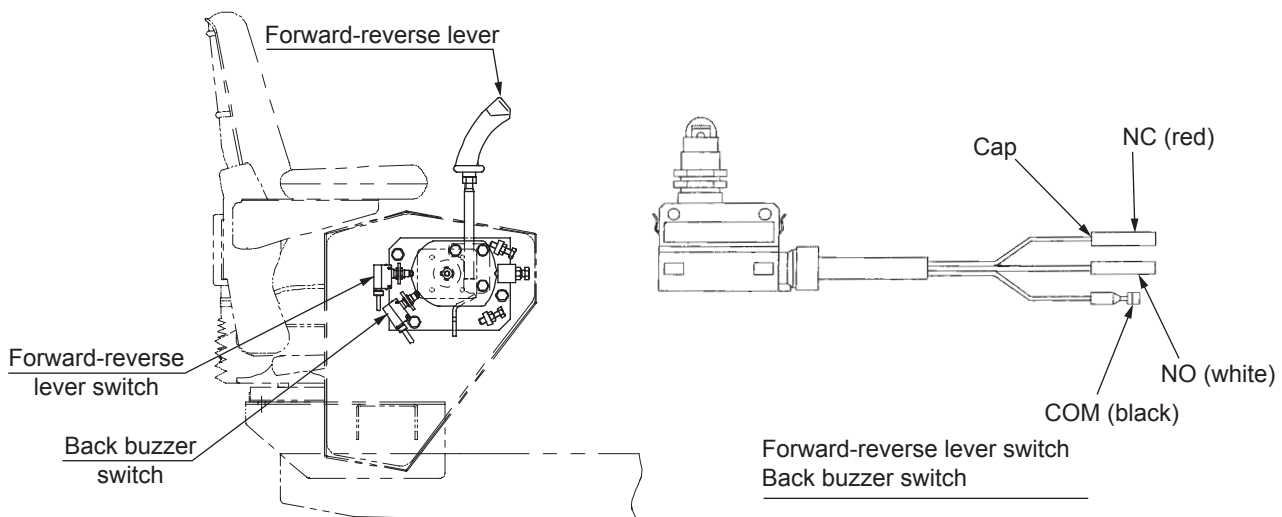
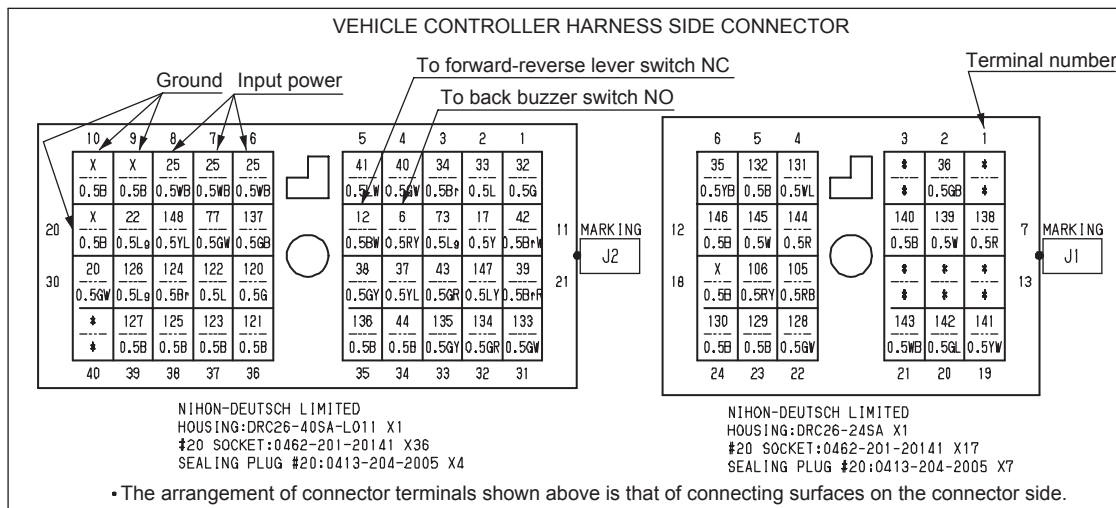
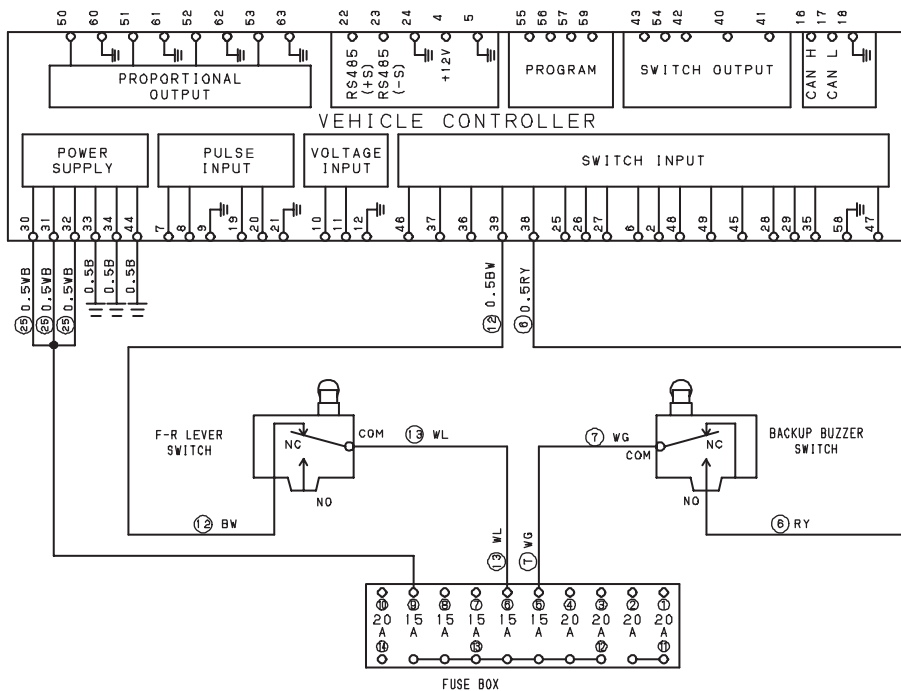

2-5-1. Vehicle moves neither forward nor backward (2/5)

- Check whether the display shows any error code.
- The parking brake switch is OFF (brake OFF).
- The foot brake switch is ON (brake OFF).

Reference Fig. : 2-5-2

1) When the display shows any error code

Error code	Check point	Check/Cause	Action
E 03 or E 04	1. Connector	- Check the forward-reverse lever switch connector and vehicle controller connector (pin 39) for corrosion, breakage, bending and looseness. - If any abnormality is found, the connector is faulty.	Replace the connector or terminal.
	2. Harness	(1) Measure the resistance between the forward-reverse lever switch connector terminal BW wire and the vehicle controller connector pin 39 BW wire. Standard resistance: 10 Ω or less (2) Measure the resistance between the forward-reverse lever switch connector terminal WL wire and the fuse box 6 input WL wire. Standard resistance: 10 Ω or less - If the resistance is abnormal, the harness is faulty.	Repair or replace the harness.
	3. Forward-Reverse Lever Switch	(1) When the forward-reverse lever switch is in the neutral position and the starter switch is OFF, check the continuity between the forward-reverse lever switch COM terminal inlet and the NC terminal. There is continuity in the normal condition. (2) When the forward-reverse lever is in the forward or reverse position and the starter switch is OFF, check the continuity between the forward-reverse lever switch COM terminal inlet and the NO terminal. There is continuity in the normal condition. - If the item (1) or (2) is NG, the forward-reverse lever switch is faulty.	Replace the forward-reverse lever switch.
	4. Vehicle Controller	- If the error code E 03 or E 04 is displayed and no abnormality is found in the connector, harness and forward-reverse lever switch in the above inspections, the vehicle controller is faulty.	Replace the vehicle controller.

Fig. : 2-5-2

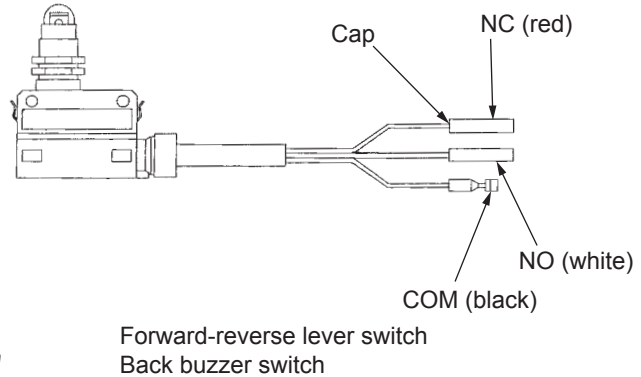
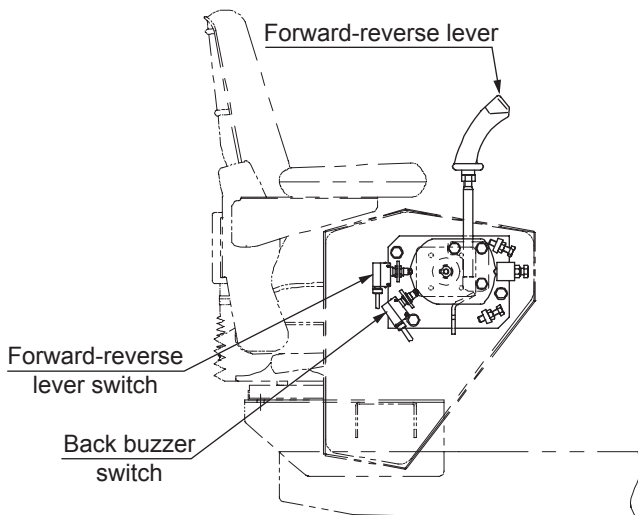
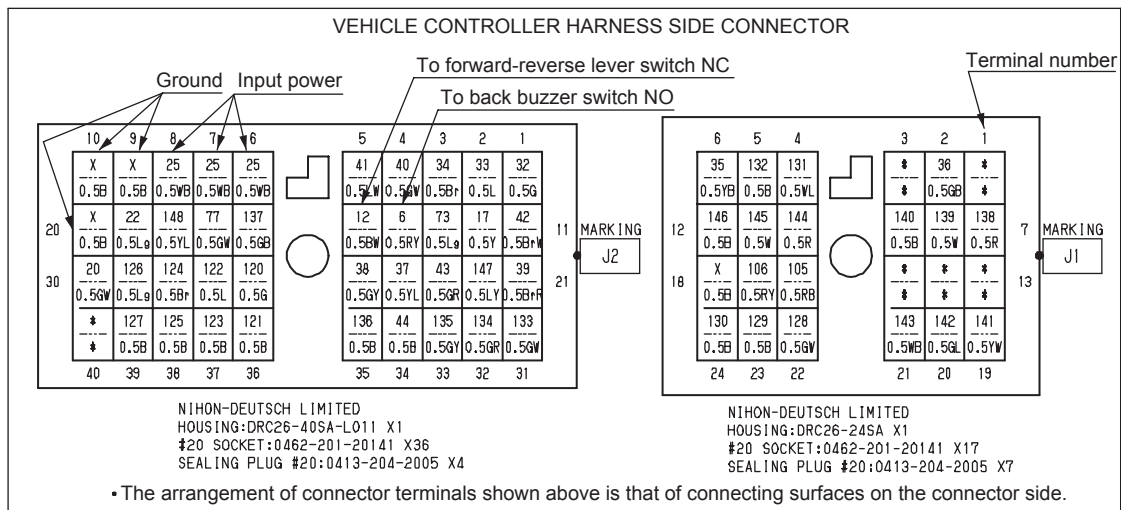
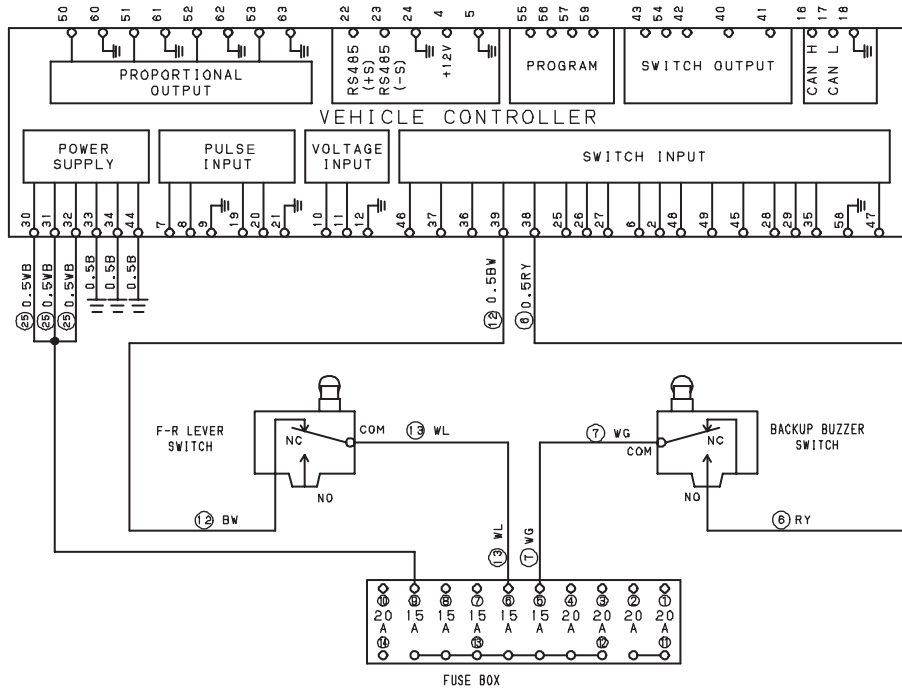

2-5-1. Vehicle moves neither forward nor backward (3/5)

- Check whether the display shows any error code.
- The parking brake switch is OFF (brake OFF).
- The foot brake switch is ON (brake OFF).

Reference Fig. : 2-5-2

1) When the display shows any error code

Error code	Check point	Check/Cause	Action
E 05 or E 06	1. Connector	- Check the back buzzer switch connector and vehicle controller connector (pin 38) for corrosion, breakage, bending and looseness. - If any abnormality is found, the connector is faulty.	Replace the connector or terminal.
	2. Harness	- Measure the resistance between the back buzzer switch connector terminal RY wire and the vehicle controller connector pin 38 RY wire. Standard resistance: 10 Ω or less - If the resistance is abnormal, the harness is faulty.	Repair or replace the harness.
	3. Back Buzzer Switch	(1) When the forward-reverse lever is in the neutral position and the starter switch is OFF, check the continuity between the back buzzer switch COM terminal inlet and the NC terminal. There is no continuity in the normal condition. (2) When the forward-reverse lever is in the forward position and the starter switch is OFF, check the continuity between the back buzzer switch COM terminal inlet and the NC terminal. There is no continuity in the normal condition. (3) When the forward-reverse lever is in the reverse position and the starter switch is OFF, check the continuity between the back buzzer switch COM terminal inlet and the NC terminal. There is continuity in the normal condition. - If any of the items (1), (2) and (3) is NG, the back buzzer switch is faulty.	Replace the back buzzer switch.
	4. Vehicle Controller	- If the error code E 05 or E 06 is displayed and no abnormality is found in the connector, harness and back buzzer switch in the above inspections, the vehicle controller is faulty.	Replace the vehicle controller.

Fig. : 2-5-3

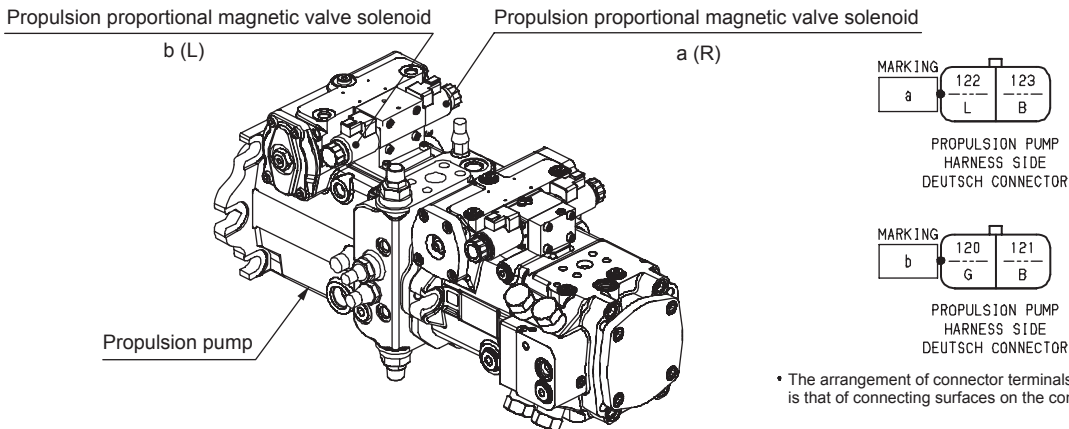
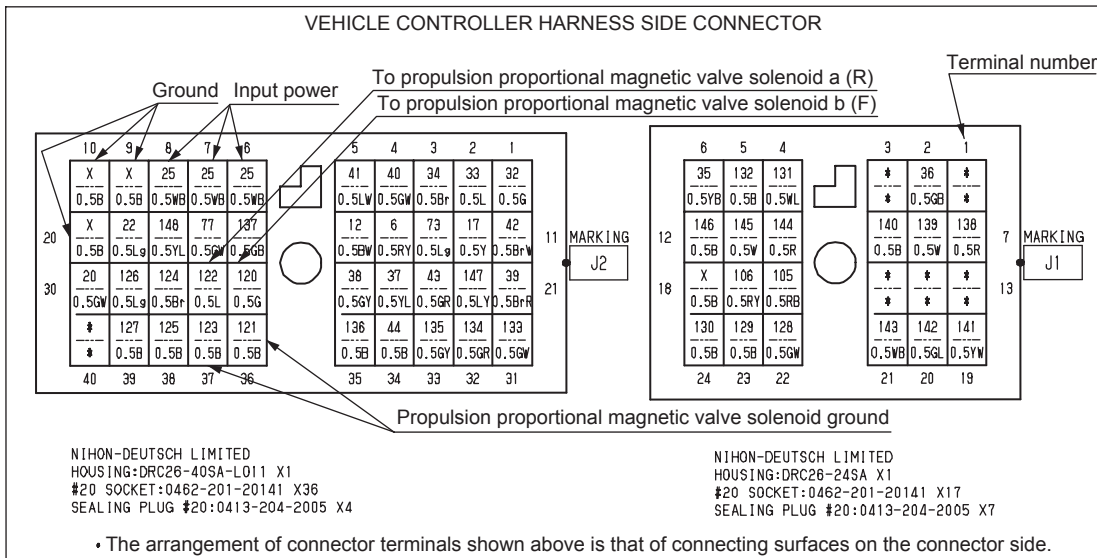
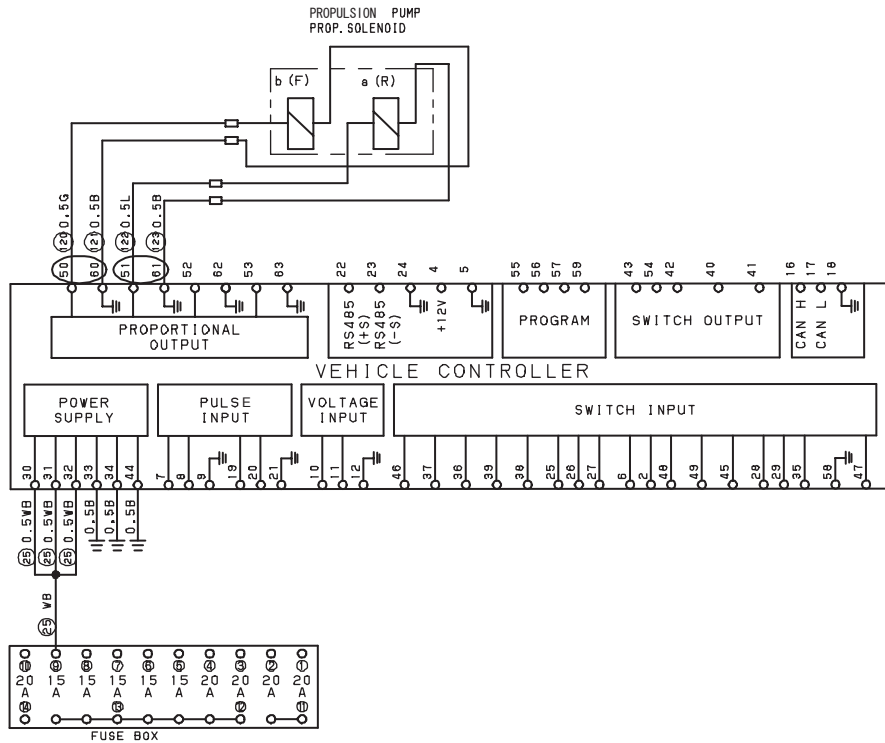

2-5-1. Vehicle moves neither forward nor backward (4/5)

- Check whether the display shows any error code.
- The parking brake switch is OFF (brake OFF).
- The foot brake switch is ON (brake OFF).

Reference Fig. : 2-5-3

1) When the display shows any error code

Error code	Check point	Check/Cause	Action
E 31 or E 32	1. Connector	<ul style="list-style-type: none"> - Check the propulsion proportional magnetic valve solenoid connector and vehicle controller connector (pins 60 and 61) for corrosion, breakage, bending and looseness. - If any abnormality is found, the connector is faulty. 	Replace the connector or terminal.
	2. Harness	<ul style="list-style-type: none"> - Measure the resistance between the propulsion proportional magnetic valve solenoid connector terminal G, L and B wires and the vehicle controller connector pin 60 G and B wires and pin 61 L and B wires. Standard resistance: 10 Ω or less - If the resistance is abnormal, the harness is faulty. <p>(NOTICE)</p> <ul style="list-style-type: none"> • Since shielded twisted wires are used for the vehicle controller terminal harness, repair is not approved. Be sure to replace them. 	Replace the harness.
	3. Propulsion Proportional Magnetic Valve Solenoid F or R	<ul style="list-style-type: none"> - Disconnect the harness for the propulsion proportional magnetic valve solenoid F or R and measure the resistance of the coil. Standard resistance: 5.5 Ω - If the resistance is abnormal, the corresponding propulsion proportional magnetic valve solenoid F or R is faulty. 	Replace the propulsion proportional magnetic valve solenoid F or R.
	4. Vehicle Controller	<p>(1) When the starter switch is ON, measure the voltage between the vehicle controller input power supply pins 30, 31 and 32 and the ground terminals 33, 34 and 44.</p> <p>Standard voltage: 12V or more</p> <p>(2) When the starter switch is ON and the propulsion speed selector switch is in the drive position ( position), measure the current between the propulsion proportional magnetic valve solenoid F terminal G wire (positive side) and the B wire (ground side).</p> <p>Or, measure the current between the propulsion proportional magnetic valve solenoid R terminal L wire (positive side) and the B wire (ground side).</p> <p>While measuring the current, operate the forward-reverse lever from the neutral position to the full forward or reverse position.</p> <p>Standard current: 200 mA (neutral position) Standard current: 410 mA or more (at starting) Standard current: 1,350 mA or less (full forward or reverse position)</p> <ul style="list-style-type: none"> - If the item (1) is OK and the item (2) is NG, the vehicle controller is faulty. <p>(NOTICE)</p> <ul style="list-style-type: none"> • Refer to the description of current measurement methods (P.11-007). Since the current value is output in PWM, the standard values shown above represent a maximum instantaneous value. 	

Fig. : 2-5-4



Neutral relay (1)
Neutral holding relay

Neutral relay (2)

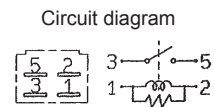
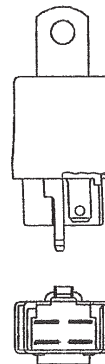
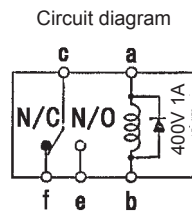
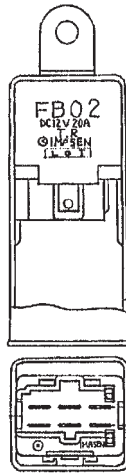
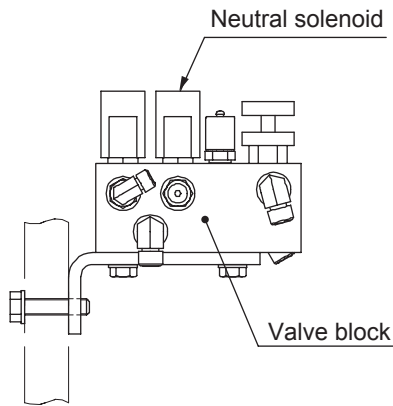
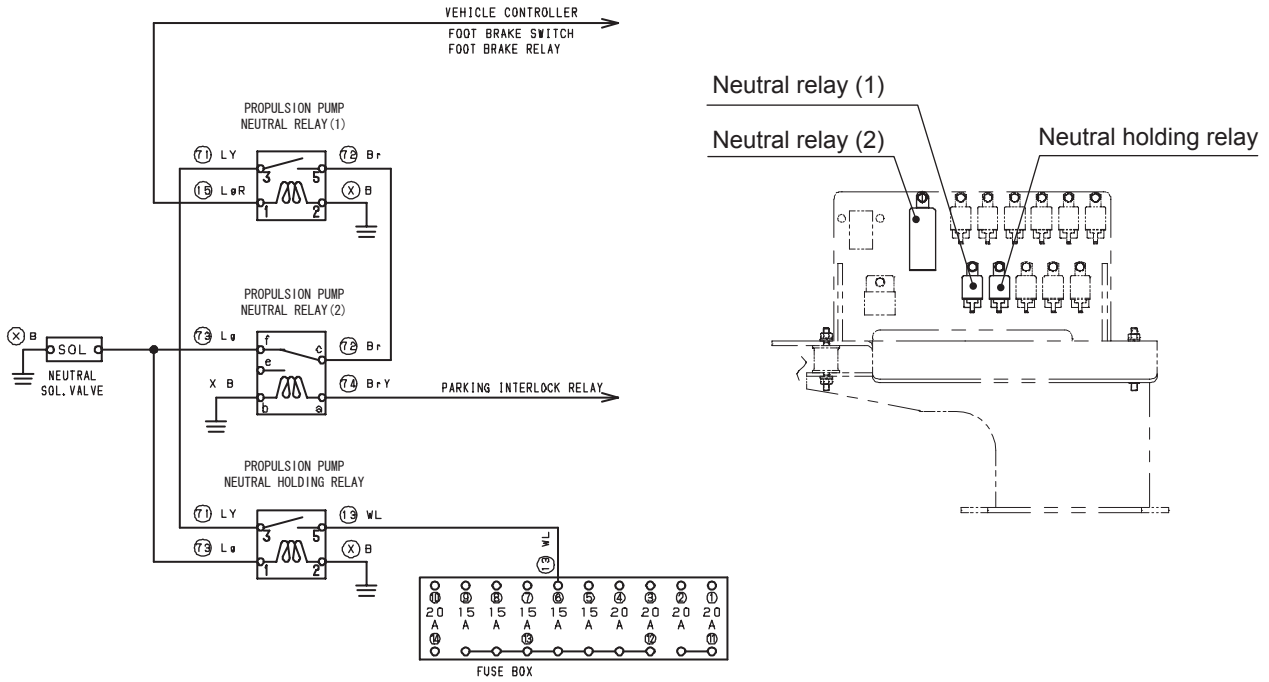
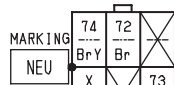

YAZAKI
7123-2262
(RB6B-SL)
NEUTRAL RELAY (2)
HARNES SIDE CONNECTOR

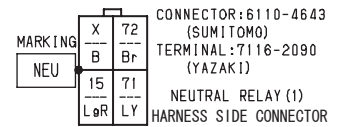

CONNECTOR: 6110-4643
(SUMITOMO)
TERMINAL: 7116-2090
(YAZAKI)
NEUTRAL RELAY (1)
HARNES SIDE CONNECTOR

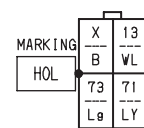

CONNECTOR: 6110-4643
(SUMITOMO)
TERMINAL: 7116-2090
(YAZAKI)
HOLDING RELAY
HARNES SIDE CONNECTOR

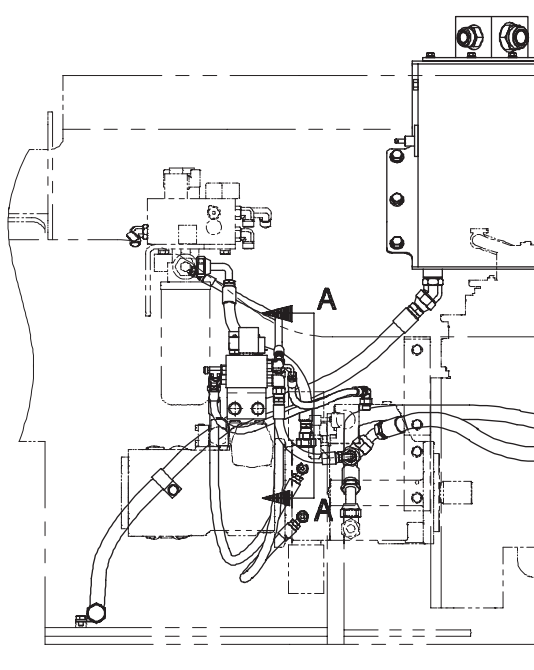

• The arrangement of connector terminals shown above is that of connecting surfaces on the connector side.

2-5-1. Vehicle moves neither forward nor backward (5/5)

- Check whether the display shows any error code.
- The parking brake switch is OFF (brake OFF).
- The foot brake switch is ON (brake OFF).

Reference Fig. : 2-5-4

2) When the display shows no error code

- The forward-reverse lever is in the neutral position.
- The brake is OFF.

Check point	Check/Cause	Action
1. Neutral Solenoid	<ul style="list-style-type: none"> - Disconnect the harness for the neutral solenoid and measure the resistance of the coil. Standard resistance: 12.3 Ω - If the resistance is abnormal, the neutral solenoid is faulty. 	Replace the neutral solenoid.
2. Neutral Relay (1)	<ul style="list-style-type: none"> (1) When the starter switch is ON, measure the voltage between the neutral relay (1) pin 1 inlet LgR wire and the ground pin 2 B wire. Standard voltage: 12V or more (2) When the starter switch is ON, measure the voltage between the neutral relay (1) pin 3 inlet LY wire and the chassis ground. Standard voltage: 12V or more (3) When the starter switch is ON, measure the voltage between the neutral relay (1) pin 5 inlet Br wire and the chassis ground. Standard voltage: 12V or more - If the above items (1) and (2) are OK and the item (3) is NG, the neutral relay (1) is faulty. 	Replace the neutral relay (1).
3. Neutral Relay (2)	<ul style="list-style-type: none"> (1) When the starter switch is ON, measure the voltage between the neutral relay (2) pin "a" inlet BrY wire and the chassis ground. There is no current in the normal condition. (2) When the starter switch is ON, measure the voltage between the neutral relay (2) pin "c" inlet Br wire and the chassis ground. Standard voltage: 12V or more (3) When the starter switch is ON, measure the voltage between the neutral relay (2) pin "f" inlet Lg wire and the chassis ground. Standard voltage: 12V or more - If the above items (1) and (2) are OK and the item (3) is NG, the neutral relay (2) is faulty. 	Replace the neutral relay (2).
4. Neutral Holding Relay	<ul style="list-style-type: none"> (1) When the starter switch is ON and the forward-reverse lever switch is in any other position than neutral, measure the voltage between the neutral holding relay pin 1 inlet Lg wire and the ground pin 2 B wire. Standard voltage: 12V or more (2) When the starter switch is ON and the forward-reverse lever switch is in any other position than neutral, measure the voltage between the neutral holding relay pin 3 inlet LY wire and the chassis ground. Standard voltage: 12V or more - If the above item (1) is OK and the item (2) is NG, the neutral holding relay is faulty. 	Replace the neutral holding relay.
5. Harness Connecting Between Terminals	<ul style="list-style-type: none"> - Measure the resistance of the harness connecting between terminals. Standard resistance: 10 Ω or less - If the resistance is abnormal, the harness is faulty. 	Repair or replace the harness.

(NOTICE)

- If the standard voltage cannot be measured with the pins of the neutral relays (1), (2) and the neutral holding relay, in particular, check the relevant harness.

Fig. : 2-5-5

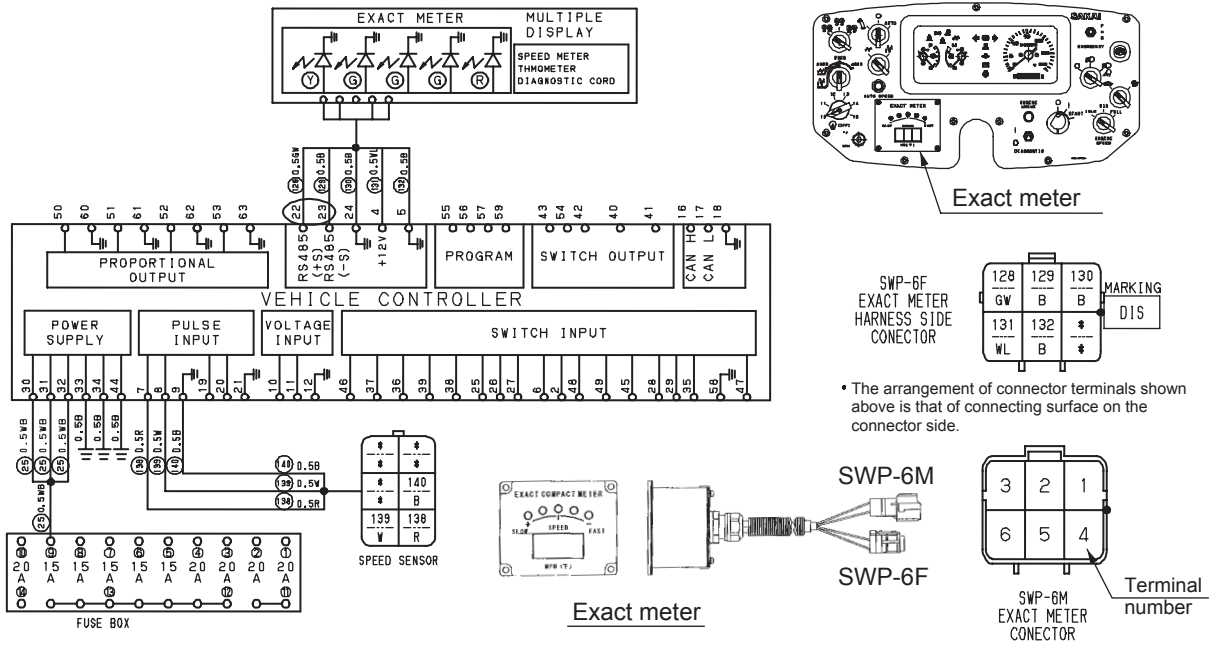

• The arrangement of connector terminals shown above is that of connecting surface on the connector side.

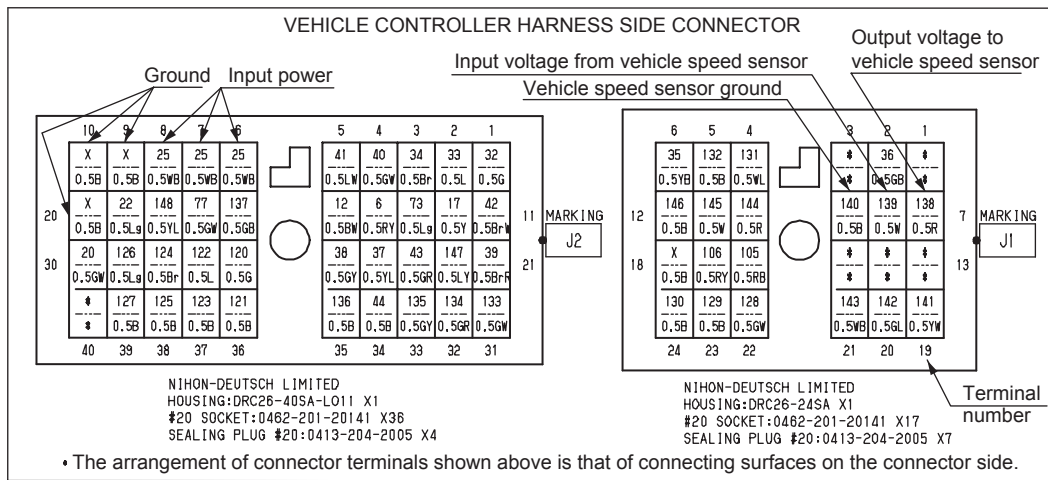

• The arrangement of connector terminals shown above is that of connecting surfaces on the connector side.

Vehicle speed sensor specifications

- Supply power voltage: 5V ± 0.25
- Maximum required current: 25mA
- Output signal: 21 pulses/rev.
- Connector: DEUTSCH DTM-Series 6-Pin DTM 04-6P

Sensor pin I/O	
1	Output signal 2
2	Revolving direction output
3	Output signal 1
4	Supply power voltage
5	0 V (GND)
6	-

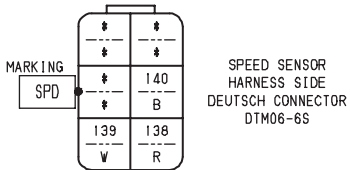
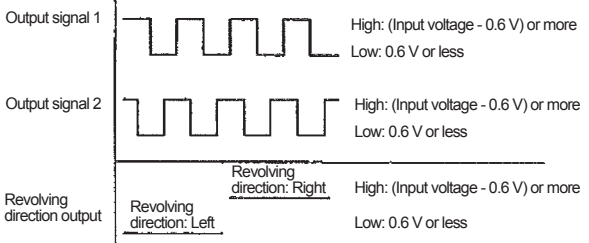
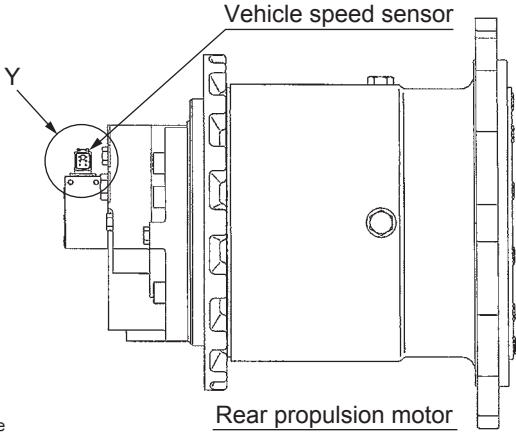
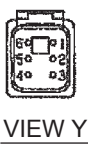

• The arrangement of connector terminals shown above is that of connecting surface on the connector side.

2-5-2. Vehicle moves neither forward nor backward only in automatic speed mode

- Check whether the display shows any error code.
- The parking brake switch is OFF (brake OFF).
- The foot brake switch is ON (brake OFF).

Reference Fig. : 2-5-5

1) When the display shows any error code

Error code	Check point	Check/Cause	Action
E 11	1. Connector	- Check the vehicle speed sensor connector and vehicle controller connector (pins 7, 8 and 9) for corrosion, breakage, bending and looseness. - If any abnormality is found, the connector is faulty.	Replace the connector or terminal.
	2. Harness	- Measure the resistance between the vehicle speed sensor connector terminal R, W and B wires and the vehicle controller connector pin 7 R wire, pin 8 W wire and pin 9 B wire. Standard resistance: 10 Ω or less - If the resistance is abnormal, the harness is faulty.	Repair or replace the harness.
	3. Vehicle Speed Sensor	(1) When the starter switch is ON, measure the voltage between the vehicle speed sensor input terminal R wire and the exact meter ground terminal B wire. Standard voltage: 5V (2) Start the engine and rotate the vibratory drum. Measure the pulse between the vehicle speed sensor B and W with a pulse meter. Standard pulse: 21 pulses/rotation - If the above item (1) is OK and the item (2) is NG, the vehicle speed sensor is faulty.	Replace the vehicle speed sensor.
	4. Vehicle Controller	- If the error code E 11 is displayed and no abnormality is found in the connector, harness and vehicle speed sensor in the above inspections, the vehicle controller is faulty.	Replace the vehicle controller.

Fig. : 2-5-6

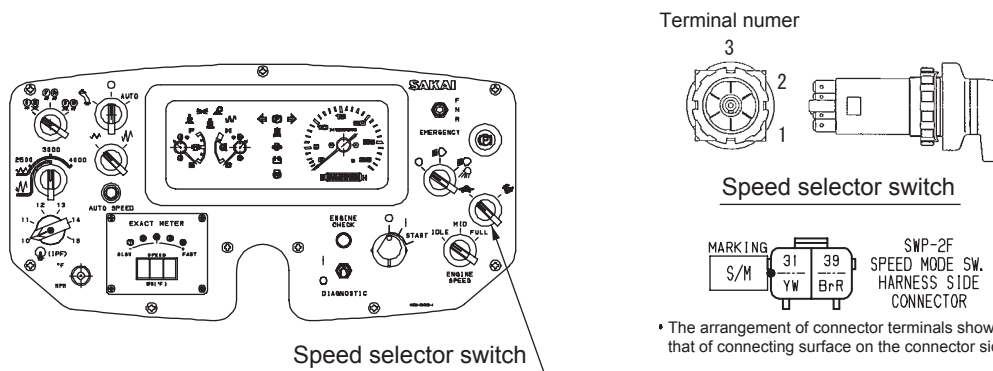
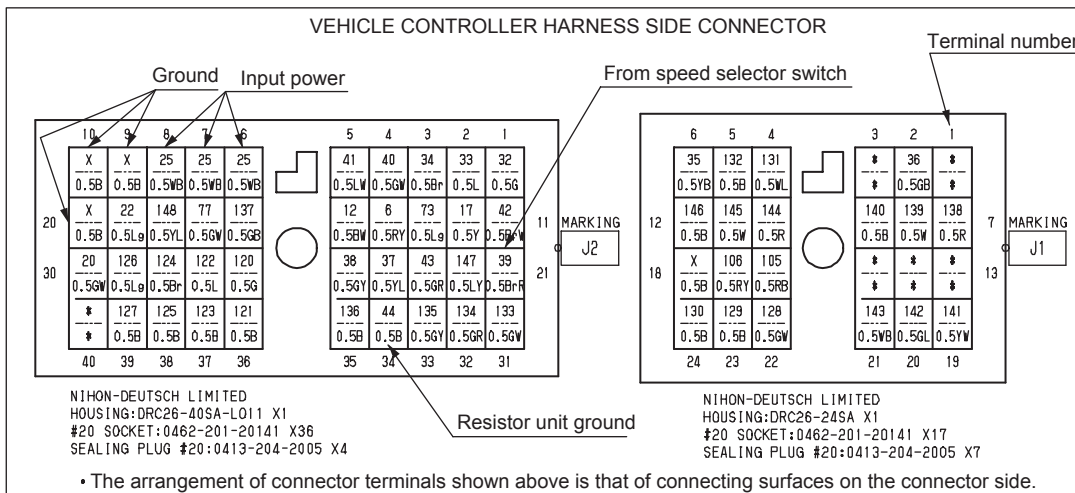
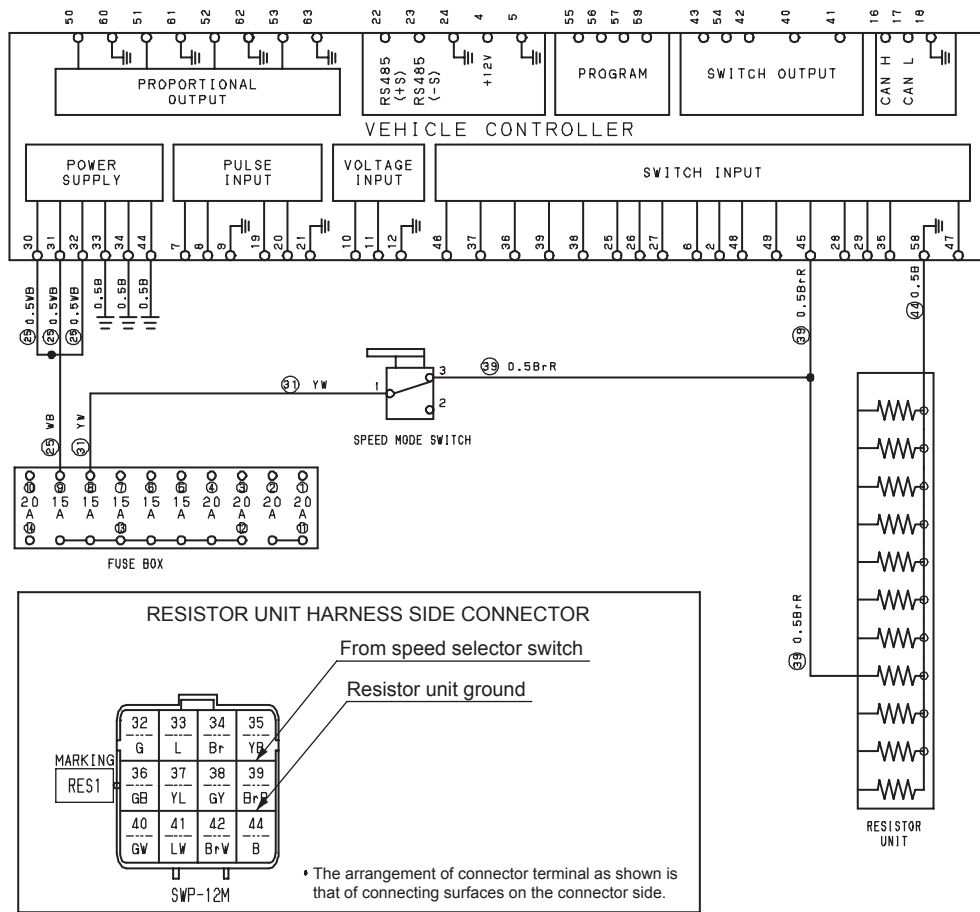

Speed selector switch

2-5-3. Vehicle speed cannot be changed

- Set the speed selector switch to the  position.

Reference Fig. : 2-5-6



Check point	Check/Cause	Action
1. Speed Selector Switch	<p>(1) When the starter switch is ON, measure the voltage between the speed selector switch pin 1 inlet YW wire and the chassis ground. Standard voltage: 12V or more</p> <p>(2) When the starter switch is ON, measure the voltage between the speed selector switch pin 3 inlet BrR wire and the chassis ground. Standard voltage: 12V or more</p> <p>(3) When the speed selector switch is switched from the work condition ( position) to the drive condition ( position) with the starter switch ON, measure the voltage between the speed selector switch pin 2 and the chassis ground. Standard voltage: 12V or more</p> <p>- If the above item (1) is OK and the item (2) or (3) is NG, the speed selector switch is faulty.</p>	Replace the speed selector switch.
2. Resistor Unit	<p>- Measure the resistance between the resistor unit terminal inlet BrR wire 39 and the B wire 44. Standard resistance: 300 Ω</p> <p>- If the resistance is abnormal, the resistor unit is faulty.</p> <p>(NOTICE)</p> <ul style="list-style-type: none"> • The resistor unit is used to stabilize the contact of the switch. 	Replace the resistor unit.
3. Vehicle Controller	<p>(1) When the starter switch is ON, measure the voltage between the vehicle controller input power supply pins 30, 31 and 32 and the ground pins 33, 34 and 44. Standard voltage: 12V or more</p> <p>(2) When the starter switch is ON, measure the voltage between the vehicle controller input supply pin 45 BrR wire and the pin 58 B wire. Standard voltage: 12V or more</p> <p>- If the above items (1) and (2) are OK, the vehicle controller is faulty.</p>	Replace the vehicle controller.
4. Harness Connecting Between Terminals	<p>- Measure the resistance of the harness connecting between terminals. Standard resistance: 10 Ω or less</p> <p>- If the resistance is abnormal, the harness is faulty.</p>	Repair or replace the harness.

Fig. : 2-5-5



The arrangement of connector terminals shown above is that of connecting surface on the connector side.

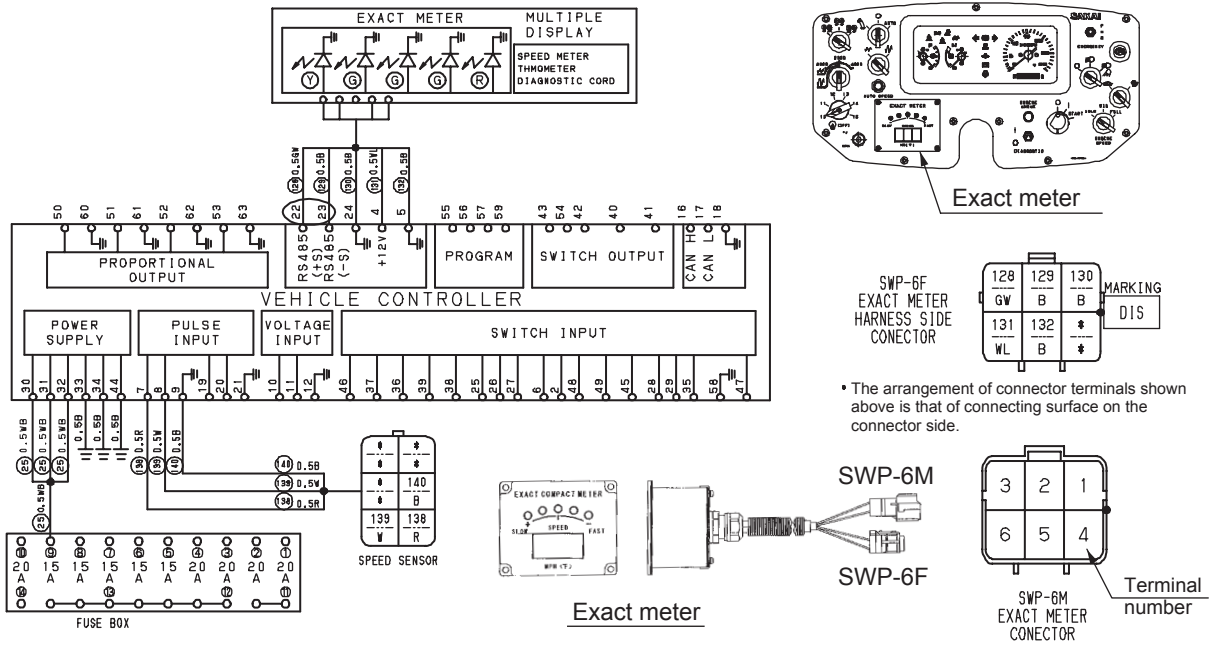
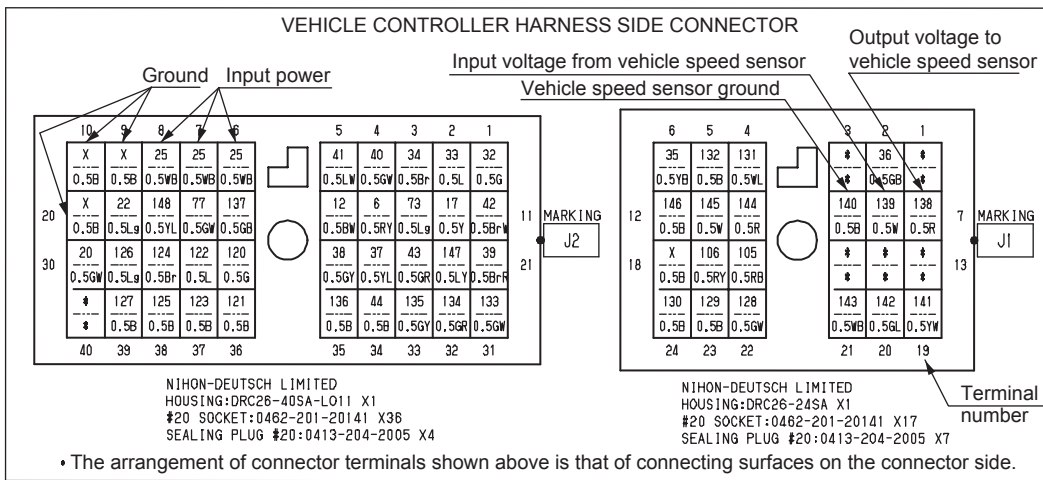

The arrangement of connector terminals shown above is that of connecting surfaces on the connector side.

Vehicle speed sensor specifications

- Supply power voltage $5V \pm 0.25$
- Maximum required current 25mA
- Output signal 21 pulses/rev.
- Connector



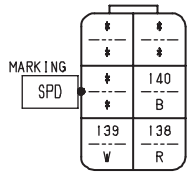
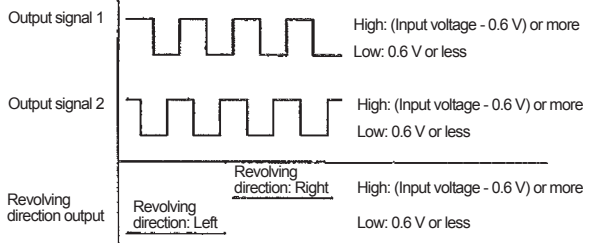
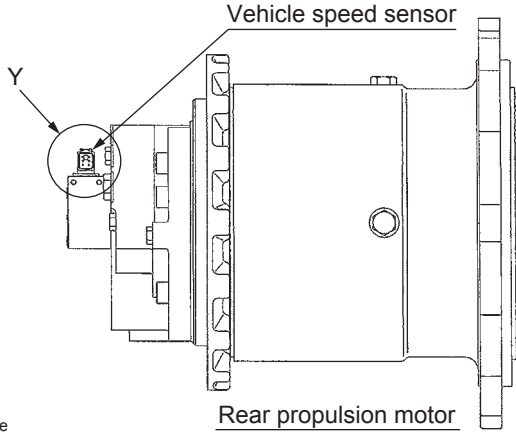

DEUTSCH DTM-Series 6-Pin
DTM 04-6P

Sensor pin I/O	
1	Output signal 2
2	Revolving direction output
3	Output signal 1
4	Supply power voltage
5	0 V (GND)
6	-



The arrangement of connector terminals shown above is that of connecting surface on the connector side.

2-5-4. Automatic speed function does not work (1/7)

- Set the speed selector switch to the  position.
(The automatic speed function is disabled when the speed selector switch is in the  position.)
- Check that the speed selector can be switched between the work speed ( position) and the drive speed ( position).
- Set the engine speed switch to the FULL position.
(The automatic speed function is disabled when the engine speed switch is in any other position than the FULL position.)

Reference Fig. : 2-5-5



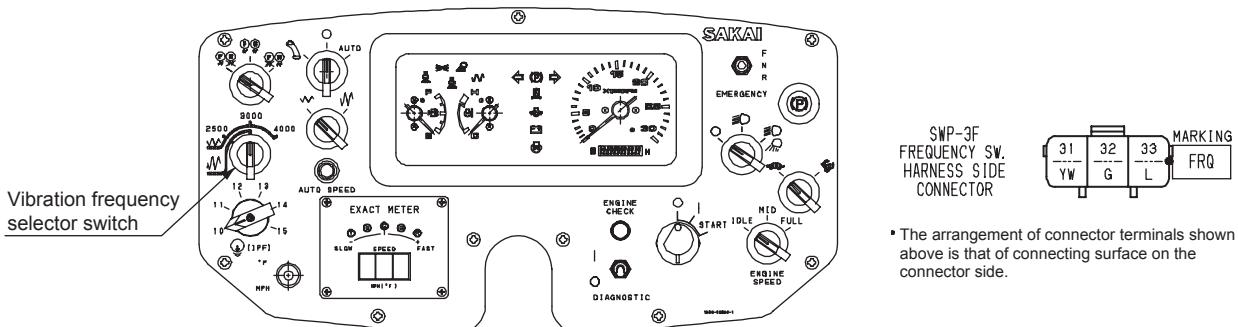
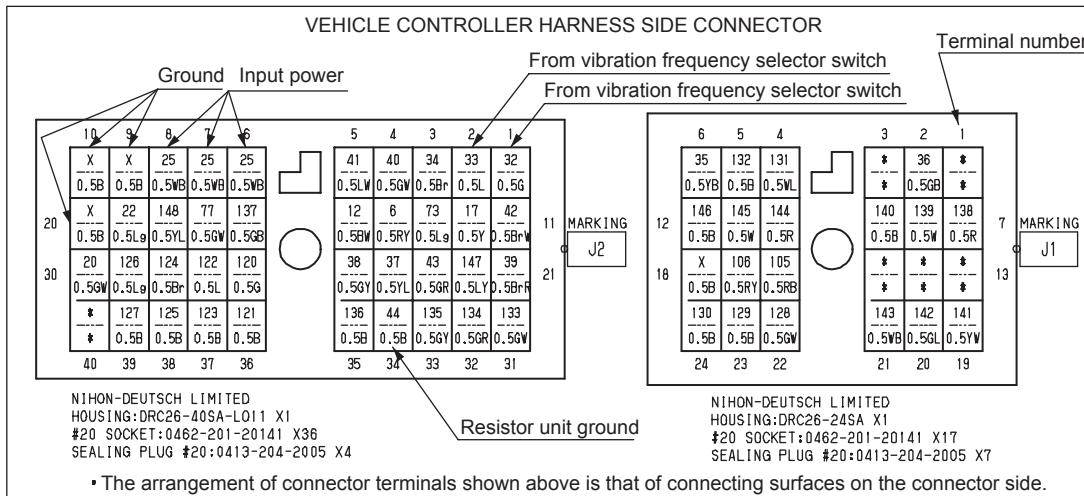
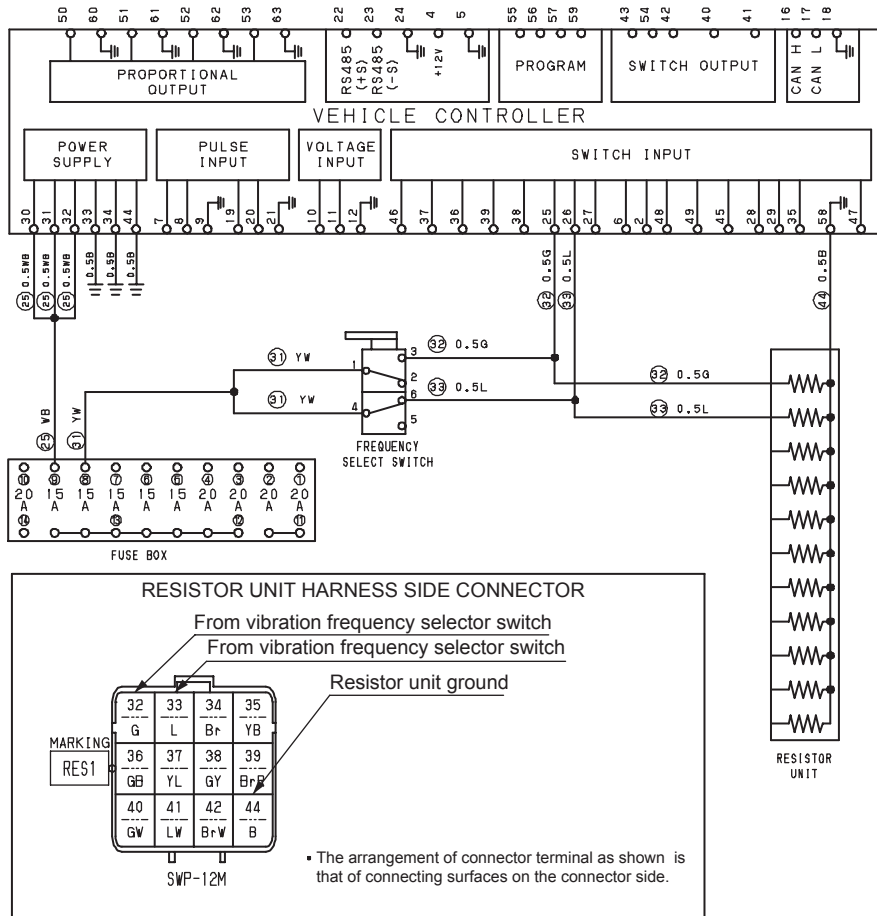

1) When the display shows any error code

Error code	Check point	Check/Cause	Action
E 11	1. Connector	- Check the speed sensor connector and vehicle controller connector (pins 7, 8 and 9) for corrosion, breakage, bending and looseness. - If any abnormality is found, the connector is faulty.	Replace the connector or terminal.
	2. Harness	- Measure the resistance between the speed sensor connector terminal R, W and B wires and the vehicle controller connector pin 7 R wire, pin 8 W wire and pin 9 B wire. Standard resistance: 10 Ω or less - If the resistance is abnormal, the harness is faulty.	Repair or replace the harness.
	3. Speed Sensor	(1) When the starter switch is ON, measure the voltage between the speed sensor input terminal R wire and the exact meter ground terminal B wire. Standard voltage: 5V (2) Start the engine and rotate the drum. Measure the pulse between the speed sensor terminal W wire and the speed sensor ground terminal B wire with a pulse meter. Standard pulse: 21 pulses/rotation - If the above item (1) is OK and the item (2) is NG, the speed sensor is faulty.	Replace the speed sensor.
	4. Vehicle Controller	- If the error code E 11 is displayed and no abnormality is found in the connector, harness and speed sensor in the above inspections, the vehicle controller is faulty.	Replace the vehicle controller.

Fig. : 2-5-7



2-5-4. Automatic speed function does not work (2/7)

- Set the speed selector switch to the  position.
(The automatic speed function is disabled when the speed selector switch is in the  position.)
- Check that the speed selector can be switched between the work speed ( position) and the drive speed ( position).
- Set the engine speed switch to the FULL position.
(The automatic speed function is disabled when the engine speed switch is in any other position than the FULL position.)

Reference Fig. : 2-5-7



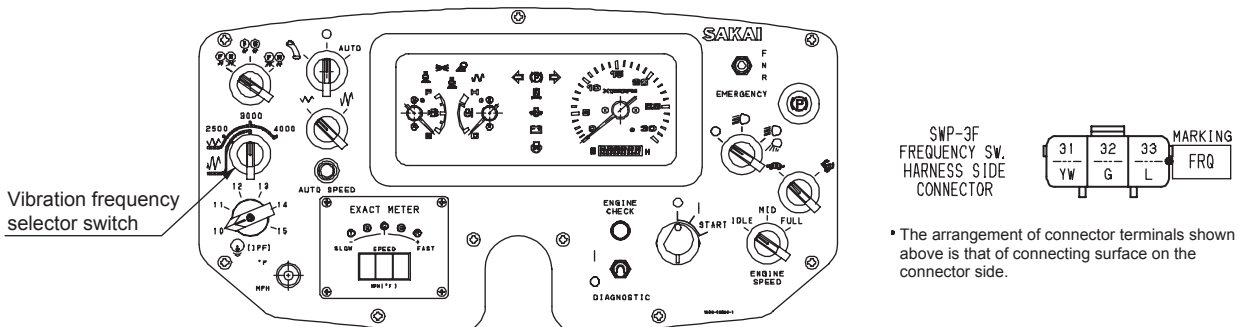
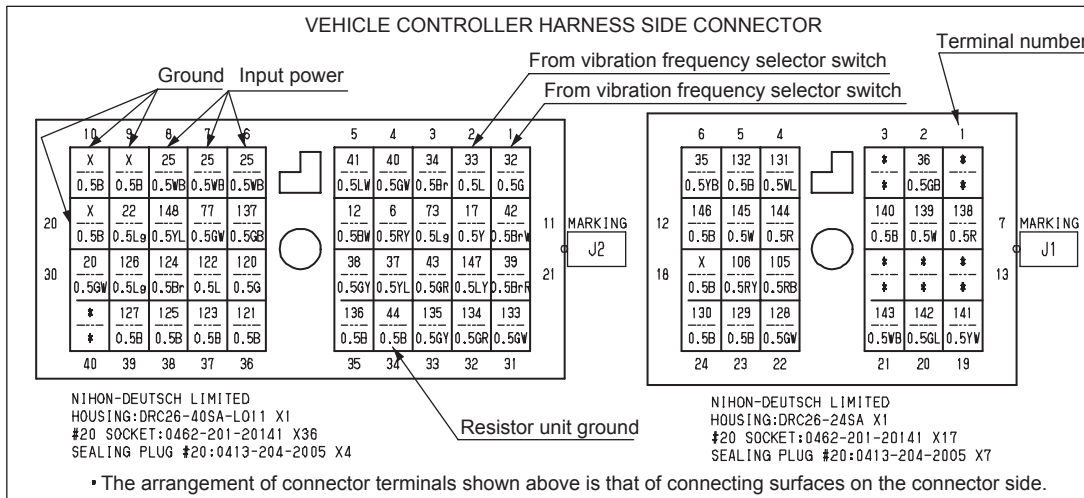
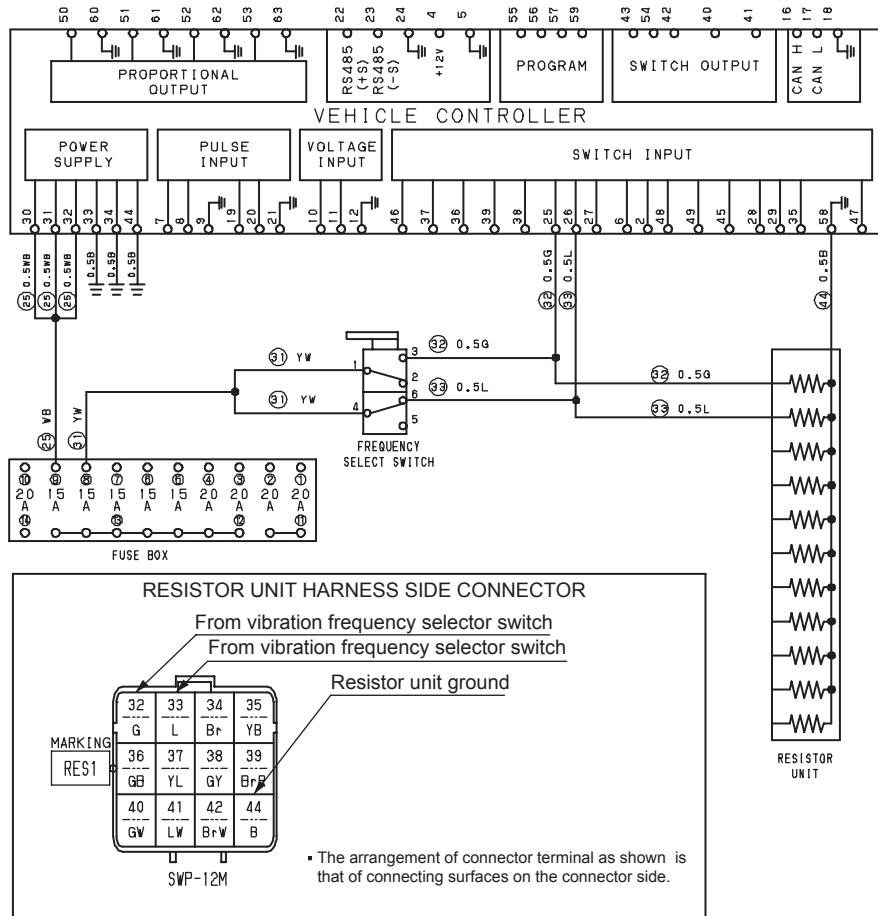

1) When the display shows any error code

Error code	Check point	Check/Cause	Action
E 21	1. Connector	- Check the frequency selector switch connector and vehicle controller connector (pins 25 and 26) for corrosion, breakage, bending and looseness. - If any abnormality is found, the connector is faulty.	Replace the connector or terminal.
	2. Harness	(1) Measure the resistance between the frequency selector switch connector terminal G and L wires and the vehicle controller connector pin 25 G wire and 26 L wire. Standard resistance: 10 Ω or less (2) Measure the resistance between the frequency selector switch connector terminal YW wire and the fuse box pin 8 input YW wire. Standard resistance: 10 Ω or less - If the resistance is abnormal, the harness is faulty.	Repair or replace the harness.
	3. Frequency Selector Switch	(1) When the starter switch is ON, measure the voltage between the frequency selector switch pins 1 and 4 inlet YW wires and the chassis ground. Standard voltage: 12V or more (2) When the starter switch is ON and the frequency selector switch is set to 2,500 vpm, measure the voltage between the frequency selector switch pin 6 inlet L wire and the chassis ground. Standard voltage: 12V or more (3) When the starter switch is ON and the frequency selector switch is set to 3,000 vpm, measure the voltage between the frequency selector switch pins 3 and 6 inlet G and L wires and the chassis ground. Standard voltage: 12V or more (4) When the starter switch is ON and the frequency selector switch is set to 4,000 vpm, measure the voltage between the frequency selector switch pin 3 inlet G wire and the chassis ground. Standard voltage: 12V or more - If the item (1) is OK and the item (2), (3) or (4) is NG, the frequency selector switch is faulty.	Replace the frequency selector switch.

Fig. : 2-5-7



2-5-4. Automatic speed function does not work (3/7)

- Set the speed selector switch to the  position.
(The automatic speed function is disabled when the speed selector switch is in the  position.)
- Check that the speed selector can be switched between the work speed ( position) and the drive speed ( position).
- Set the engine speed switch to the FULL position.
(The automatic speed function is disabled when the engine speed switch is in any other position than the FULL position.)

Reference Fig. : 2-5-7

1) When the display shows any error code



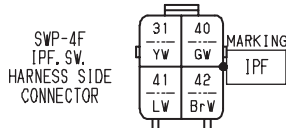
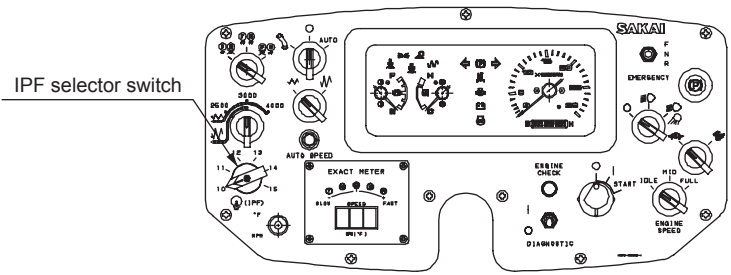
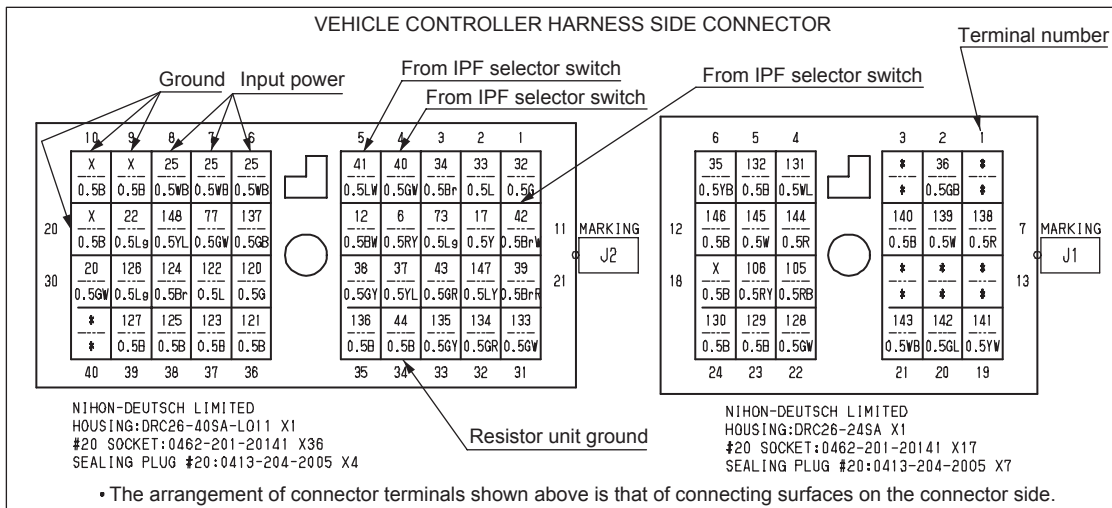
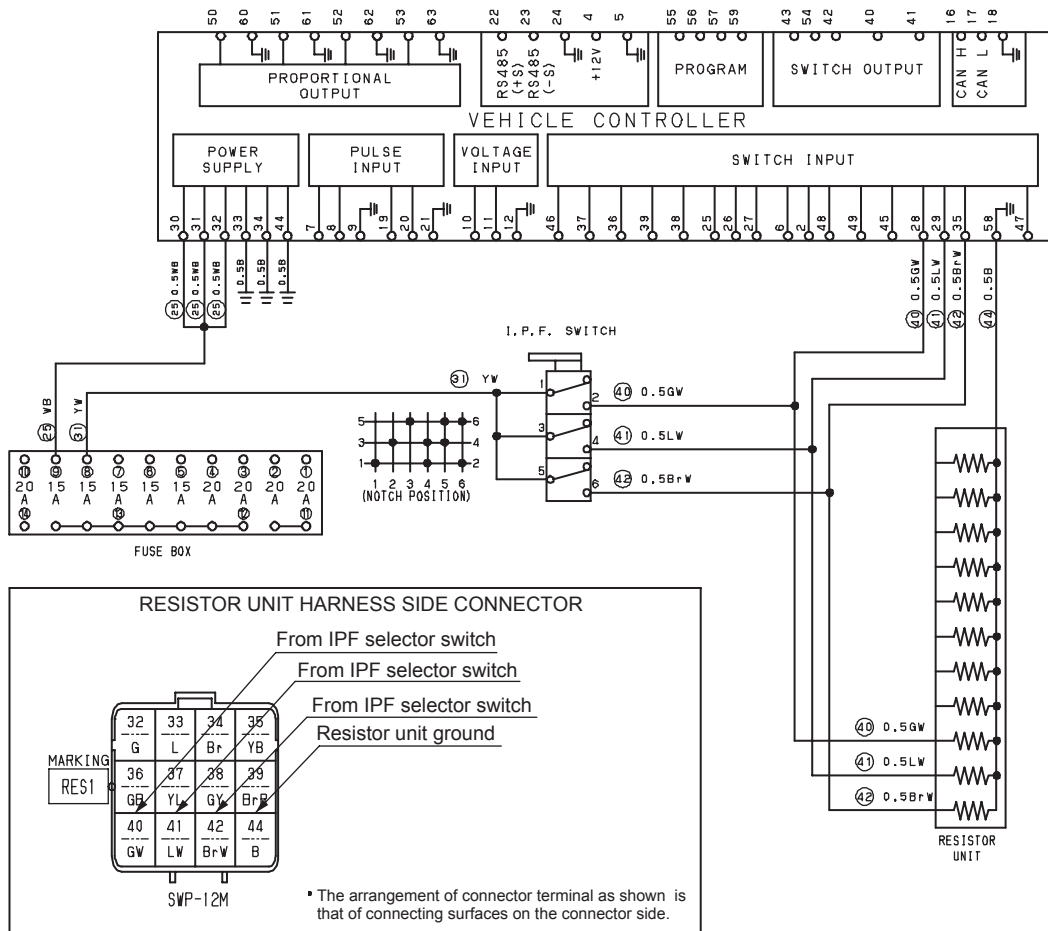

Error code	Check point	Check/Cause	Action
E 21	4. Resistor Unit	<p>(1) Measure the resistance between the resistor unit terminal input G wire 32 and the B wire 44. Standard resistance: 300 Ω</p> <p>(2) Measure the resistance between the resistor unit terminal input L wire 33 and the B wire 44. Standard resistance: 300 Ω</p> <p>- If the item (1) or (2) is NG, the resistor unit is faulty.</p> <p>(NOTICE)</p> <ul style="list-style-type: none"> • The resistor unit is used to stabilize the contact of the switch. 	Replace the resistor unit.
	5. Vehicle Controller	<p>(1) When the starter switch is ON, measure the voltage between the vehicle controller input power supply pins 30, 31 and 32 and the ground terminals 33, 34 and 44. Standard voltage: 12V or more</p> <p>(2) When the starter switch is ON and the frequency selector switch is set to 2,500 vpm, measure the voltage between the vehicle controller pin 26 L wire and the pin 58 B wire. Standard voltage: 12V or more</p> <p>(3) When the starter switch is ON and the frequency selector switch is set to 3,000 vpm, measure the voltage between the vehicle controller pin 25 and 26 G and L wires and the pin 58 B wire. Standard voltage: 12V or more</p> <p>(4) When the starter switch is ON and the frequency selector switch is set to 4,000 vpm, measure the voltage between the vehicle controller pin 25 G wire and the pin 58 B wire. Standard voltage: 12V or more</p> <p>- If all of the items (1), (2), (3) and (4) are OK, the vehicle controller is faulty.</p>	Replace the vehicle controller.

Fig. : 2-5-8



• The arrangement of connector terminals shown above is that of connecting surface on the connector side.

2-5-4. Automatic speed function does not work (4/7)

- Set the speed selector switch to the  position.
(The automatic speed function is disabled when the speed selector switch is in the  position.)
- Check that the speed selector can be switched between the work speed ( position) and the drive speed ( position).
- Set the engine speed switch to the FULL position.
(The automatic speed function is disabled when the engine speed switch is in any other position than the FULL position.)

Reference Fig. : 2-5-8

1) When the display shows any error code



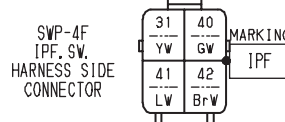
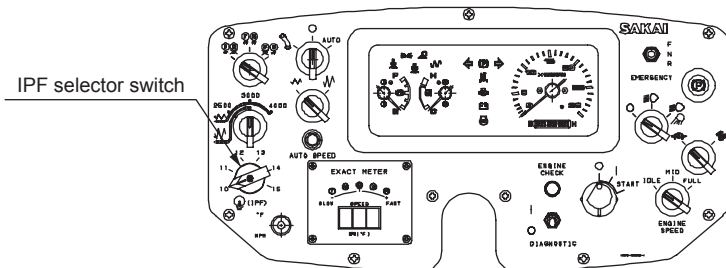
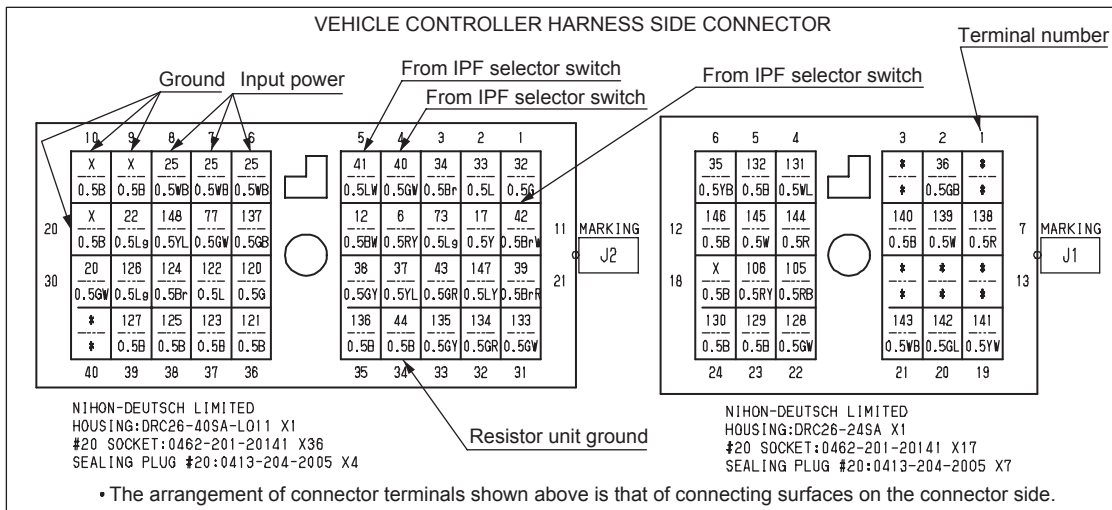
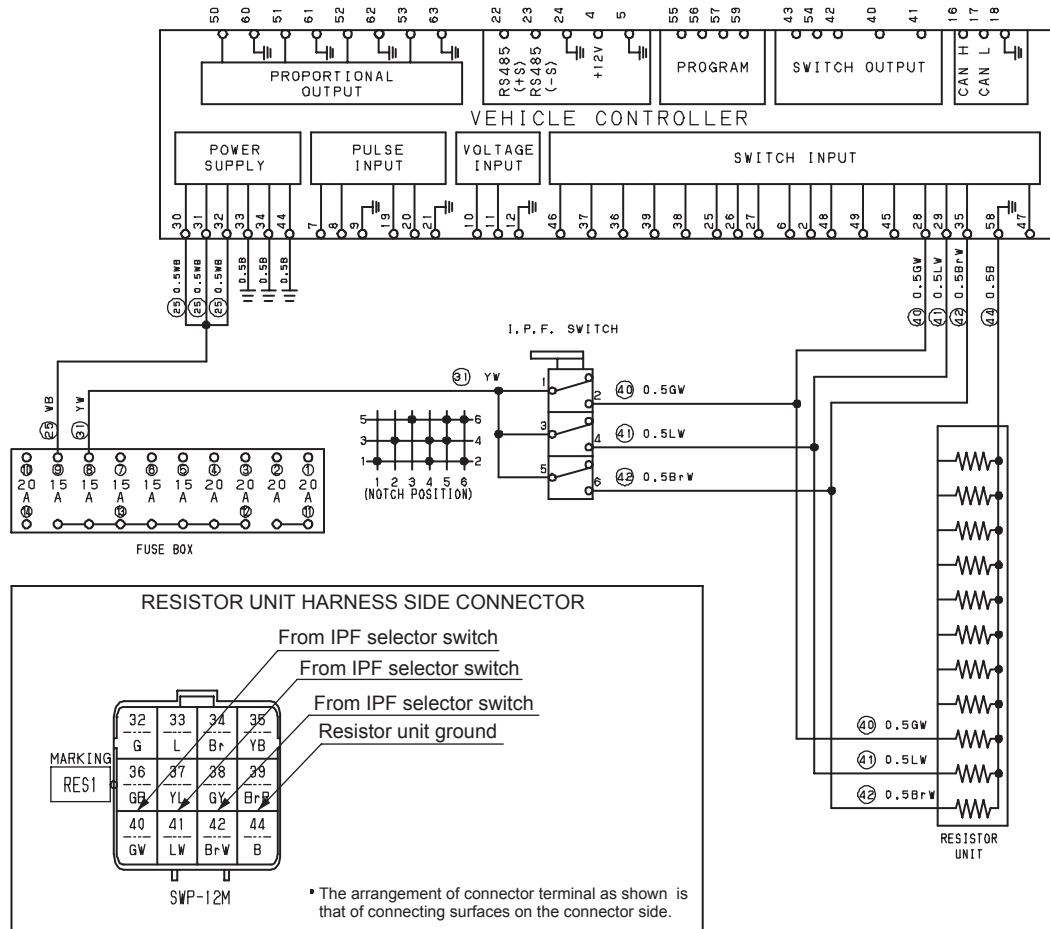

Error code	Check point	Check/Cause	Action
E 22	1. Connector	- Check the IPF selector switch connector and vehicle controller connector (pins 28, 29 and 35) for corrosion, breakage, bending and looseness. - If any abnormality is found, the connector is faulty.	Replace the connector or terminal.
	2. Harness	(1) Measure the resistance between the IPF selector switch connector terminal GW, LW and BrW wires and the vehicle controller connector pin 28 GW wire, pin 29 LW wire and pin 35 BrW wire. Standard resistance: 10 Ω or less (2) Measure the resistance between the IPF selector switch connector terminal YW wire and the fuse box pin 8 input YW wire. Standard resistance: 10 Ω or less - If the resistance is abnormal, the harness is faulty.	Repair or replace the harness.
	3. IPF Selector Switch	(1) When the starter switch is ON, measure the voltage between the IPF selector switch pins 1, 3 and 5 inlet YW wires and the chassis ground. Standard voltage: 12V or more (2) When the starter switch is ON and the IPF selector switch is in the 10 (IPF) position, measure the voltage between the IPF selector switch pin 2 inlet GW wires and the chassis ground. Standard voltage: 12V or more (3) When the starter switch is ON and the IPF selector switch is in the 11 (IPF) position, measure the voltage between the IPF selector switch pin 4 inlet LW wire and the chassis ground. Standard voltage: 12V or more (4) When the starter switch is ON and the IPF selector switch is in the 12 (IPF) position, measure the voltage between the IPF selector switch pin 6 inlet BrW wire and the chassis ground. Standard voltage: 12V or more (5) When the starter switch is ON and the IPF selector switch is in the 13 (IPF) position, measure the voltage between the IPF selector switch pins 2 and 4 inlet GW and LW wires and the chassis ground. Standard voltage: 12V or more (6) When the starter switch is ON and the IPF selector switch is in the 14 (IPF) position, measure the voltage between the IPF selector switch pins 4 and 6 inlet LW and BrW wires and the chassis ground. Standard voltage: 12V or more (7) When the starter switch is ON and the IPF selector switch is in the 15 (IPF) position, measure the voltage between the IPF selector switch pins 2 and 6 inlet GW and BrW wires and the chassis ground. Standard voltage: 12V or more - If the above item (1) is OK and any of the items (2) through (7) is NG, the IPF selector switch is faulty.	Replace the IPF selector switch.

Fig. : 2-5-8



• The arrangement of connector terminals shown above is that of connecting surface on the connector side.

2-5-4. Automatic speed function does not work (5/7)

- Set the speed selector switch to the  position.
(The automatic speed function is disabled when the speed selector switch is in the  position.)
- Check that the speed selector can be switched between the work speed ( position) and the drive speed ( position).
- Set the engine speed switch to the FULL position.
(The automatic speed function is disabled when the engine speed switch is in any other position than the FULL position.)

Reference Fig. : 2-5-8

1) When the display shows any error code

Error code	Check point	Check/Cause	Action
E 22	4. Vehicle Controller	<p>(1) When the starter switch is ON, measure the voltage between the vehicle controller input power supply pins 30, 31 and 32 and the ground terminals 33, 34 and 44. Standard voltage: 12V or more</p> <p>(2) When the starter switch is ON and the IPF selector switch is in the 10 (IPF) position, measure the voltage between the vehicle controller pin 28 inlet GW wire and the pin 58 inlet B wire. Standard voltage: 12V or more</p> <p>(3) When the starter switch is ON and the IPF selector switch is in the 11 (IPF) position, measure the voltage between the vehicle controller pin 29 inlet LW wire and the pin 58 inlet B wire. Standard voltage: 12V or more</p> <p>(4) When the starter switch is ON and the IPF selector switch is in the 12 (IPF) position, measure the voltage between the vehicle controller pin 35 inlet BrW wires and the pin 58 inlet B wire. Standard voltage: 12V or more</p> <p>(5) When the starter switch is ON and the IPF selector switch is in the 13 (IPF) position, measure the voltage between the vehicle controller pins 28 and 29 inlet GW and LW wires and the pin 58 inlet B wire. Standard voltage: 12V or more</p> <p>(6) When the starter switch is ON and the IPF selector switch is in the 14 (IPF) position, measure the voltage between the vehicle controller pins 29 and 35 inlet LW and BrW wires and the pin 58 inlet B wire. Standard voltage: 12V or more</p> <p>(7) When the starter switch is ON and the IPF selector switch is in the 15 (IPF) position, measure the voltage between the vehicle controller pins 28 and 35 inlet GW and BrW wires and the pin 58 inlet B wire. Standard voltage: 12V or more</p> <p>- If all of the items (1) through (7) are OK, the vehicle controller is faulty.</p>	Replace the vehicle controller.

Fig. : 2-5-9

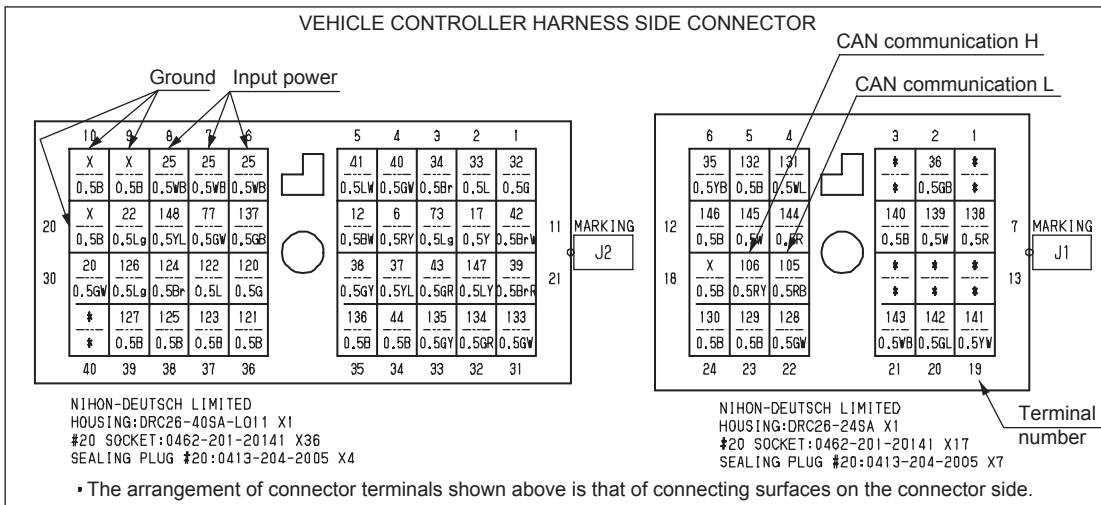
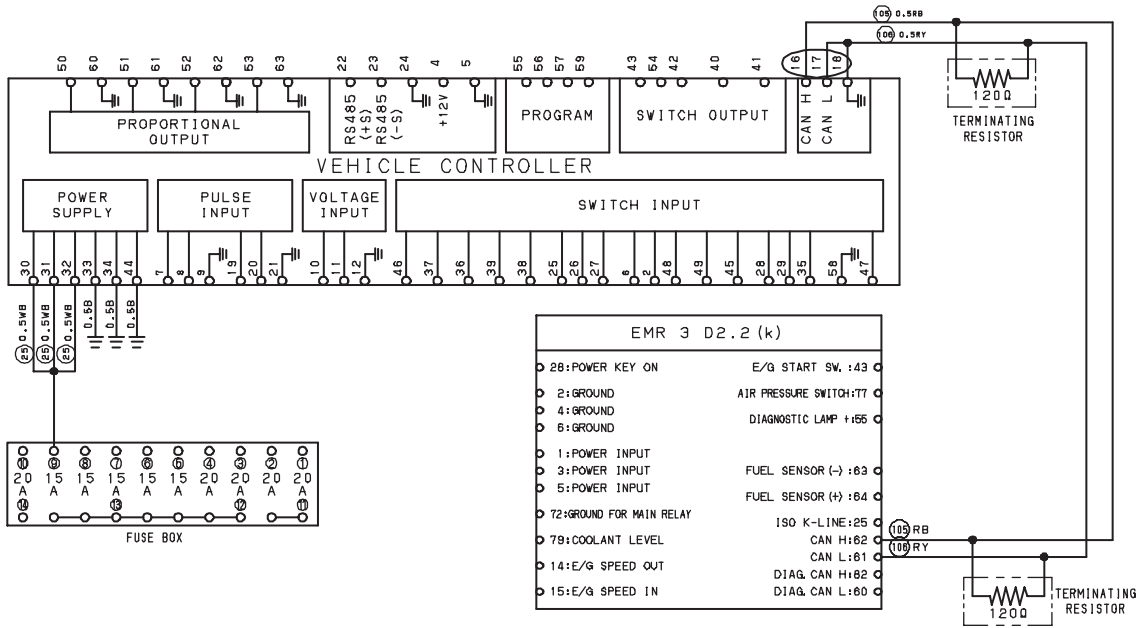

NIHON-DEUTSCH LIMITED
 HOUSING: DRC26-40SA-L011 X1
 #20 SOCKET: 0462-201-20141 X36
 SEALING PLUG #20: 0413-204-2005 X4

NIHON-DEUTSCH LIMITED
 HOUSING: DRC26-24SA X1
 #20 SOCKET: 0462-201-20141 X17
 SEALING PLUG #20: 0413-204-2005 X7

• The arrangement of connector terminals shown above is that of connecting surfaces on the connector side.

EMR CONNECTOR																			
1	2	3	4	5	6	7	8	9	10	11	12	13	14	15	16	17	18	19	20
94	X	94	X	94	X	*	*	*	*	*	*	*	97	96	*	*	*	*	*
													BrR	RW					
21	22	23	24	25	26	27	28	29	30	31	32	33	34	35	36	37	38	39	40
*	*	*	*	104	*	*	*	*	*	*	*	*	*	*	*	*	*	*	*
				BrY															
41	42	43	44	45	46	47	48	49	50	51	52	53	54	55	56	57	58	59	60
*	*	30	*	*	*	*	*	*	*	*	*	*	*	103	*	*	*	108	*
				BY										LR					Y
61	62	63	64	65	66	67	68	69	70	71	72	73	74	75	76	77	78	79	80
106	105	101	102	*	*	*	*	*	*	*	95	*	*	*	*	109	*	111	*
RY	RB	GR	GY								BY				P		LbB		
81	82	83	84	85	86	87	88	89	90	91	92	93	94						
*	*	*	*	*	*	*	*	*	*	*	*	*	*						
107																			
YB																			



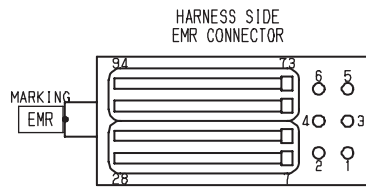

Twist shield cable

• The arrangement of connector terminals shown above is that of connecting surface on the connector side.
 • Terminals marked with asterisks are not in use.

Twist shield cable



2-5-4. Automatic speed function does not work (6/7)

- Set the speed selector switch to the  position.
(The automatic speed function is disabled when the speed selector switch is in the  position.)
- Check that the speed selector can be switched between the work speed ( position) and the drive speed ( position).
- Set the engine speed switch to the FULL position.
(The automatic speed function is disabled when the engine speed switch is in any other position than the FULL position.)

Reference Fig. : 2-5-9



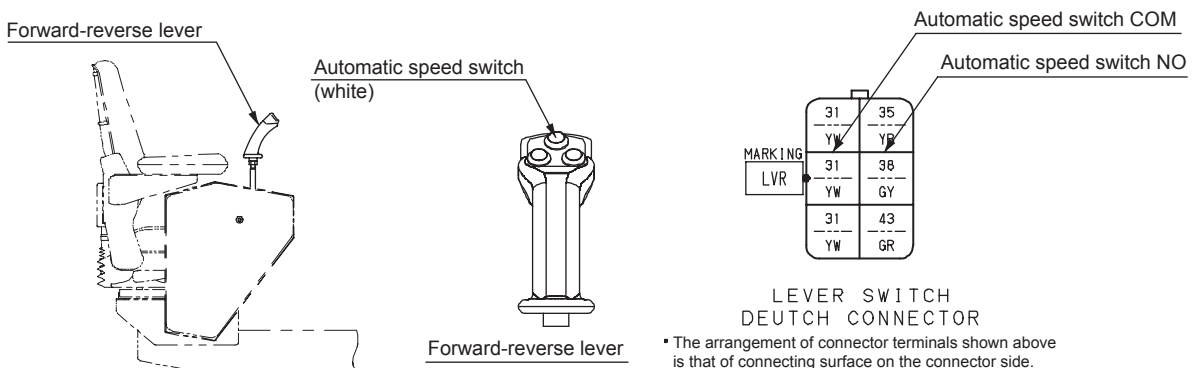
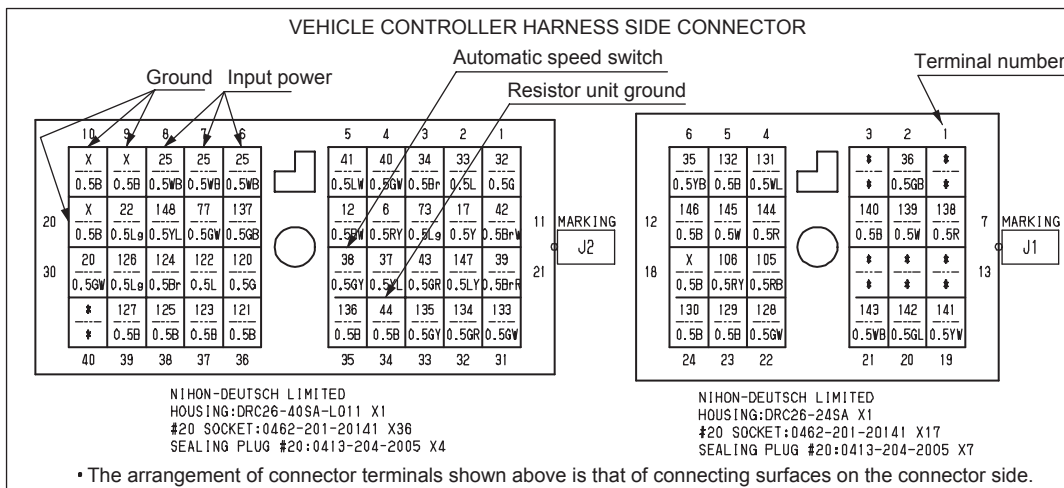
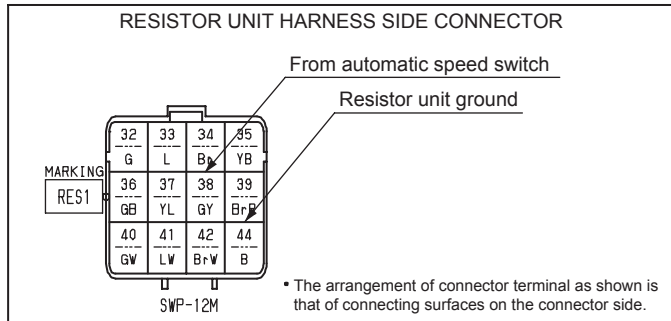
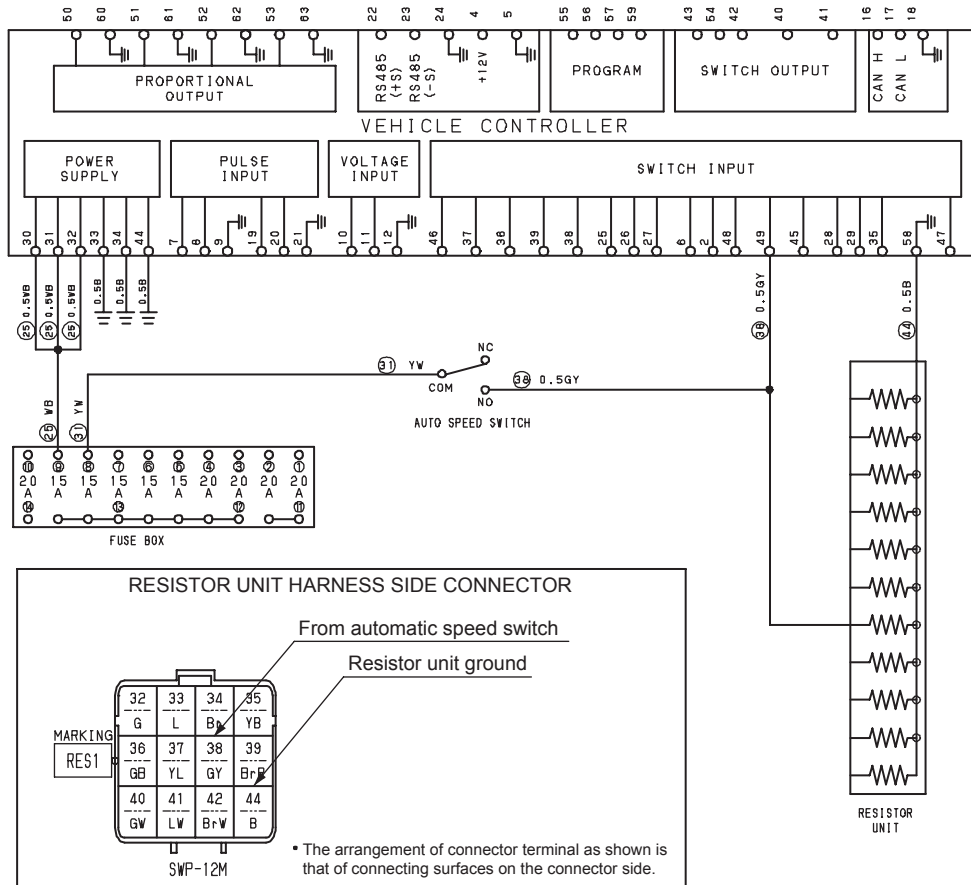

1) When the display shows any error code

Error code	Check point	Check/Cause	Action
E 41	1. Connector	- Check the EMR 3 connector (pins 61 and 62) and vehicle controller connector (pins 16 and 17) for corrosion, breakage, bending and looseness. - If any abnormality is found, the connector is faulty.	Replace the connector or terminal.
	2. Harness	- Measure the resistance between the EMR 3 connector pin 61 RY wire and pin 62 RB wire and the vehicle controller connector pin 16 RB wire and pin 17 RY wire. Standard resistance: 10 Ω or less - If the resistance is abnormal, the harness is faulty. (NOTICE) • Since shielded twisted wires are used for the vehicle controller terminal harness, repair is not approved. Be sure to replace them.	Replace the harness.
	3. CAN Communication	- Faulty CAN communication (NOTICE) • Check if any CAN-related blink code for the engine is issued. If no blink code is issued, the vehicle controller is faulty.	Replace the vehicle controller.

Fig. : 2-5-10



2-5-4. Automatic speed function does not work (7/7)

- Set the speed selector switch to the  position.
(The automatic speed function is disabled when the speed selector switch is in the  position.)
- Check that the speed selector can be switched between the work speed ( position) and the drive speed ( position).
- Set the engine speed switch to the FULL position.
(The automatic speed function is disabled when the engine speed switch is in any other position than the FULL position.)

Reference Fig. : 2-5-10

2) When the display shows no error code

Check point	Check/Cause	Action
1. Automatic Speed Switch (Forward-Reverse Lever)	<p>(1) When the starter switch is ON, measure the voltage between the automatic speed switch terminal COM inlet YW wire and the chassis ground. Standard voltage: 12V or more</p> <p>(2) When the starter switch is ON, measure the voltage between the automatic speed switch terminal NO GY wire and the chassis ground with the white button of the automatic speed switch pressed. Standard voltage: 12V or more</p> <p>- If the above item (1) is OK and the item (2) is NG, the automatic speed switch is faulty.</p>	Replace the automatic speed switch.
2. Resistor Unit	<p>- Measure the resistance between the resistor unit terminal inlet GY wire 38 and the B wire 44. Standard resistance: 300 Ω</p> <p>- If the resistance is abnormal, the resistor unit is faulty.</p> <p>(NOTICE)</p> <ul style="list-style-type: none"> • The resistor unit is used to stabilize the contact of the switch. 	Replace the resistor unit.
3. Vehicle Controller	<p>(1) When the starter switch is ON, measure the voltage between the vehicle controller pins 30, 31 and 32 and the ground pins 33, 34 and 44. Standard voltage: 12V or more</p> <p>(2) When the starter switch is ON, measure the voltage between the vehicle controller pin 49 GY wire and the pin 58 B wire with the white button of the automatic speed forward-reverse lever switch pressed. Standard voltage: 12V or more</p> <p>- If the above items (1) and (2) are OK and no error code is displayed, the vehicle controller is faulty.</p>	Replace the vehicle controller.
4. Harness Connecting Between Terminals	<p>- Measure the resistance of the harness connecting between terminals. Standard resistance: 10 Ω or less</p> <p>- If the resistance is abnormal, the harness is faulty.</p>	Repair or replace the harness.

Fig. : 2-5-11

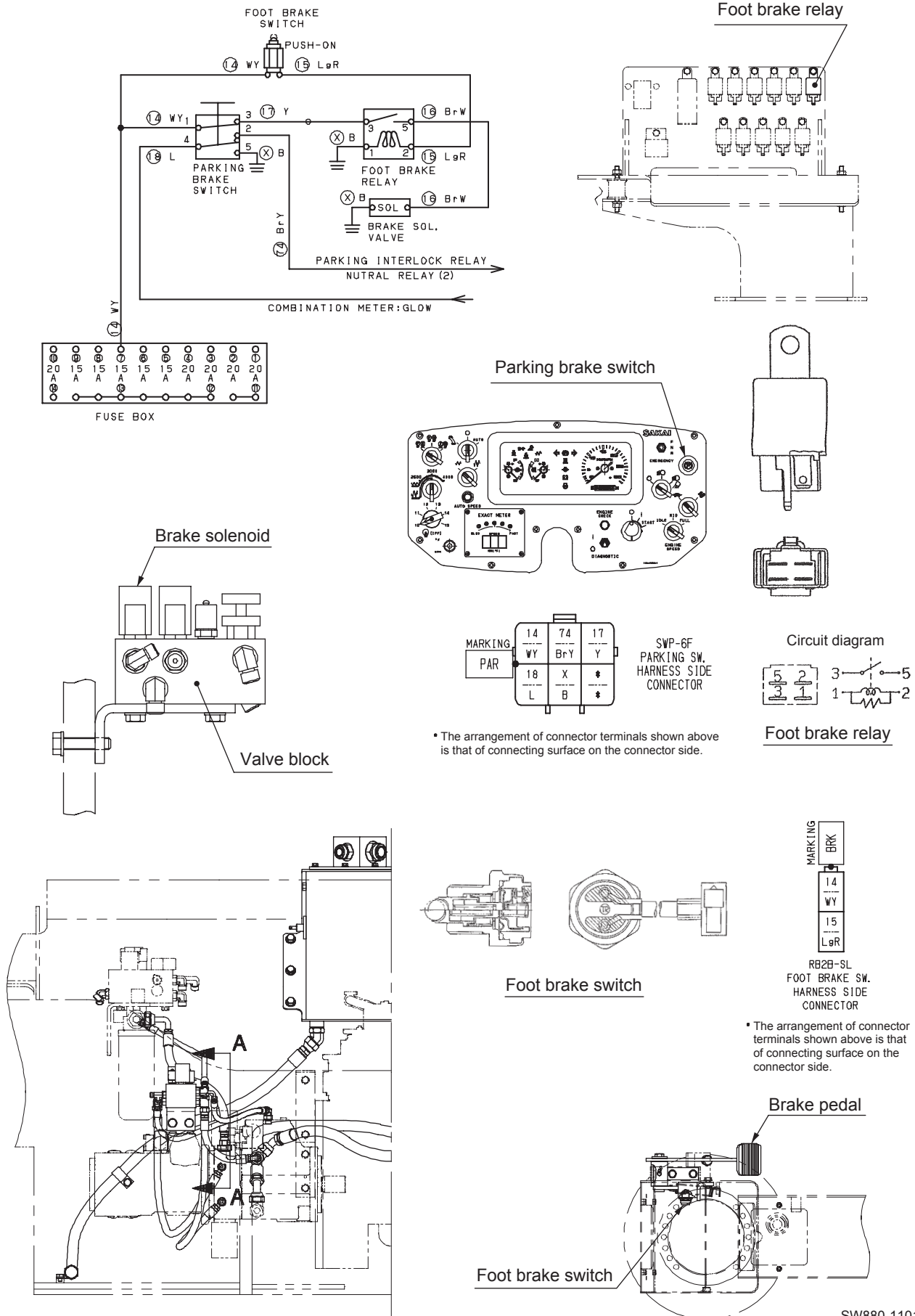

SW880-11019

2-5-5. Brake cannot be released

- The parking brake switch is OFF.
- The foot brake switch is ON (brake pedal not depressed).

Reference Fig. : 2-5-11

Check point	Check/Cause	Action
1. Brake Solenoid	<ul style="list-style-type: none"> - Disconnect the harness and measure the resistance of the coil. Standard resistance: 12.3 Ω - If measured resistance is abnormal, the brake solenoid is faulty. 	Replace the brake solenoid.
2. Foot Brake Relay	<ul style="list-style-type: none"> (1) When the starter switch is ON, measure the voltage between the foot brake relay pin 2 inlet LgR wire and the chassis ground. Standard voltage: 12V or more (2) When the starter switch is ON, measure the voltage between the foot brake relay pin 3 inlet Y wire and the chassis ground. Standard voltage: 12V or more (3) When the starter switch is ON, measure the voltage between the foot brake relay pin 5 inlet BrW wire and the chassis ground. Standard voltage: 12V or more - If the above items (1) and (2) are OK and the item (3) is NG, the foot brake relay is faulty. 	Replace the foot brake relay.
3. Parking Brake Switch	<ul style="list-style-type: none"> (1) When the starter switch is ON, measure the voltage between the parking brake switch pin 3 inlet Y wire and the chassis ground. Standard voltage: 12V or more (2) When the starter switch is ON, measure the voltage between the parking brake switch pin 1 inlet WY wire and the chassis ground. Standard voltage: 12V or more - If the above item (2) is OK and the item (1) is NG, the parking brake switch is faulty. 	Replace the parking brake switch.
4. Foot Brake Switch	<ul style="list-style-type: none"> (1) When the starter switch is ON, measure the voltage between the foot brake switch terminal inlet WY wire and the chassis ground. Standard voltage: 12V or more (2) When the starter switch is ON, measure the voltage between the foot brake switch terminal inlet LgR wire and the chassis ground. Standard voltage: 12V or more - If the above item (1) is OK and the item (2) is NG, the foot brake switch is faulty. 	Replace the foot brake switch.
5. Harness Connecting Between Terminals	<ul style="list-style-type: none"> - Measure the resistance of the harness connecting between terminals. Standard resistance: 10 Ω or less - If the resistance is abnormal, the harness is faulty. 	Repair or replace the harness.

Fig. : 2-5-11

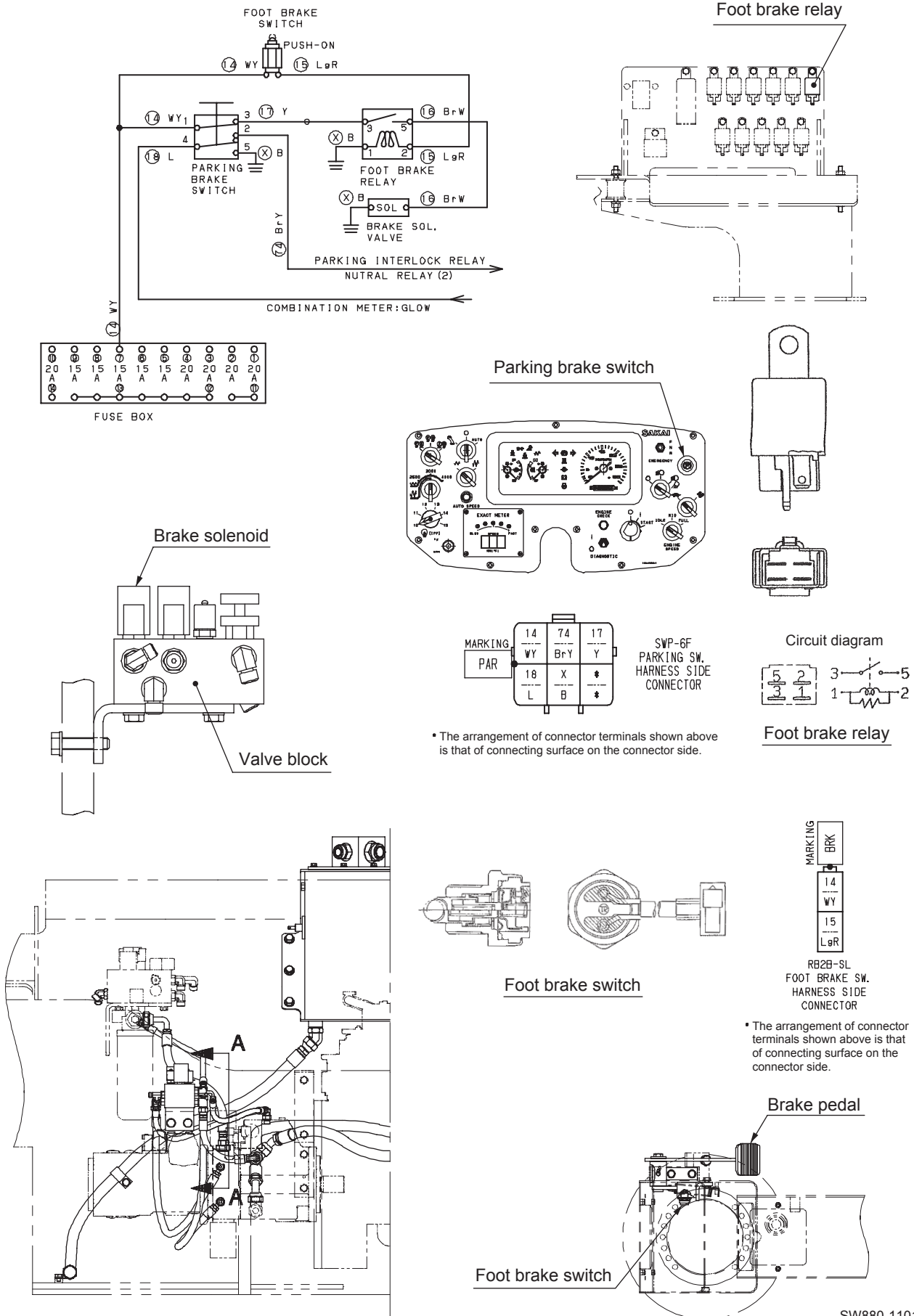

2-5-6. Brake does not operate

- When the parking brake switch is ON or the foot brake switch is OFF (brake pedal depressed)

Reference Fig. : 2-5-11

Check point	Check/Cause	Action
1. Brake Solenoid	- Disconnect the harness and measure the resistance of the coil. Standard resistance: 12.3 Ω - If measured resistance is abnormal, the brake solenoid is faulty.	Replace the brake solenoid.
2. Foot Brake Relay	- When the starter switch is ON and the foot brake switch is OFF, measure the voltage between the foot brake relay pin 5 inlet BrW wire and the chassis ground. There is no current in the normal condition. - If current is flowing, the foot brake relay is faulty.	Replace the foot brake relay.
3. Parking Brake Switch	- When the starter switch is ON and the parking brake switch is ON, measure the voltage between the parking brake switch pin 3 inlet Y wire and the chassis ground. There is no current in the normal condition. - If current is flowing, the parking brake switch is faulty.	Replace the parking brake switch.
4. Foot Brake Switch	- When the starter switch is ON and the foot brake switch is OFF, measure the voltage between the foot brake switch terminal inlet LgR wire and the chassis ground. There is no current in the normal condition. - If current is flowing, the foot brake switch is faulty.	Replace the foot brake switch.
5. Harness Connecting Between Terminals	- Measure the resistance of the harness connecting between terminals. Standard resistance: 10 Ω or less - If the resistance is abnormal, the harness is faulty.	Repair or replace the harness.

Fig. : 2-5-12

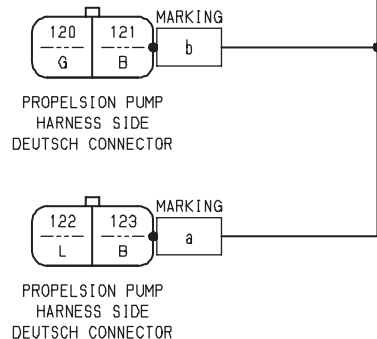
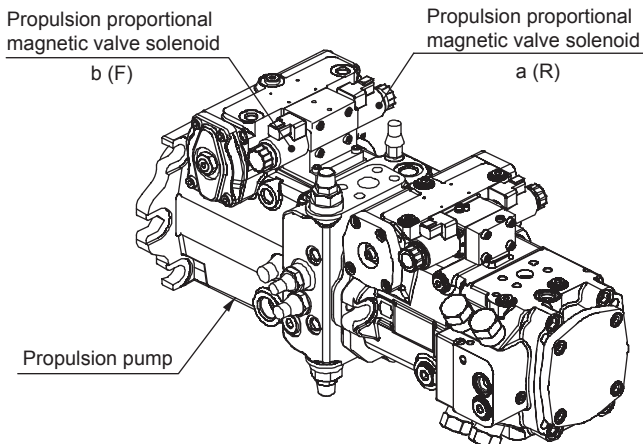
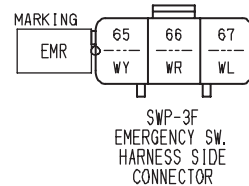
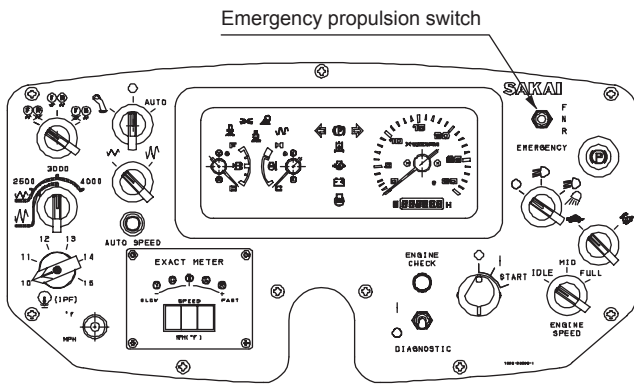
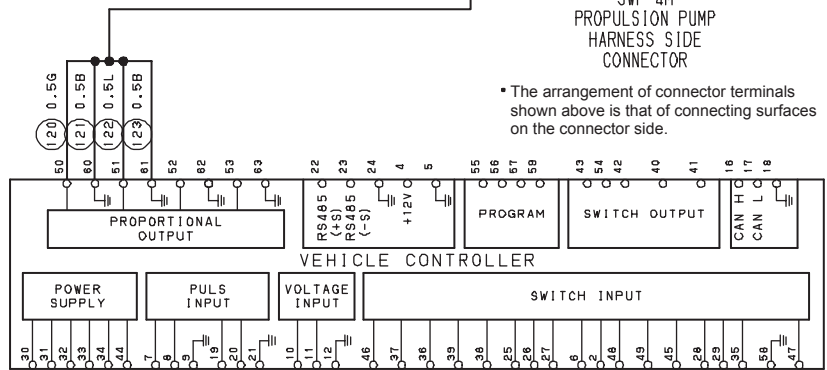
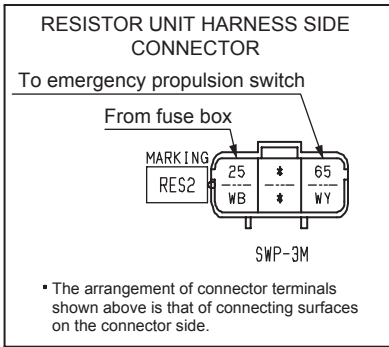
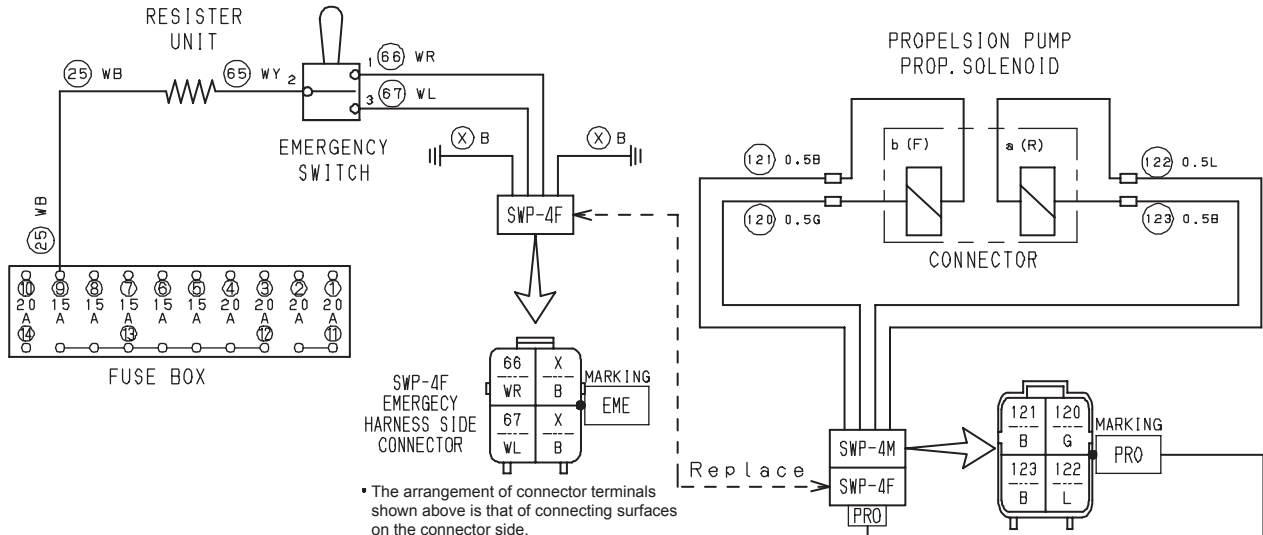

2-5-7. Emergency exit propulsion cannot be performed

- Disconnect the SWP-4F [PRO] connector from the vehicle controller and connect the emergency propulsion switch connector SWP-4F [EME].

Reference Fig. : 2-5-12

Check point	Check/Cause	Action
1. Propulsion Proportional Magnetic Valve Solenoid F or R	<ul style="list-style-type: none"> - Disconnect the harness for the propulsion proportional magnetic valve solenoid F or R and measure the resistance of the coil. Standard resistance: 5.5 Ω - If the resistance is abnormal, the corresponding propulsion proportional magnetic valve solenoid F or R is faulty. 	Replace the propulsion proportional magnetic valve solenoid F or R.
2. Emergency Propulsion Switch	<ul style="list-style-type: none"> (1) When the starter switch is ON, measure the voltage between the emergency propulsion switch pin 2 inlet WY wire and the chassis ground. Standard voltage: 12V or more (2) When setting the emergency propulsion switch to the forward or reverse position with the starter switch ON, measure the voltage between the emergency propulsion switch pin 1 inlet WR wire and pin 3 inlet WL and the chassis ground. Standard voltage: 12V or more - If the above item (1) is OK and the item (2) is NG, the emergency propulsion switch is faulty. 	Replace the emergency propulsion switch.
3. Resistor Unit	<ul style="list-style-type: none"> - Measure the resistance between the resistor unit terminal inlet WB wire 25 and the WY wire 65. Standard resistance: 15 Ω - If the resistance is abnormal, the resistor unit is faulty. 	Replace the resistor unit.
4. Harness Connecting Between Terminals	<ul style="list-style-type: none"> - Measure the resistance of the harness connecting between terminals. Standard resistance: 10 Ω or less - If the resistance is abnormal, the harness is faulty. 	Repair or replace the harness.

Fig. : 2-6-1

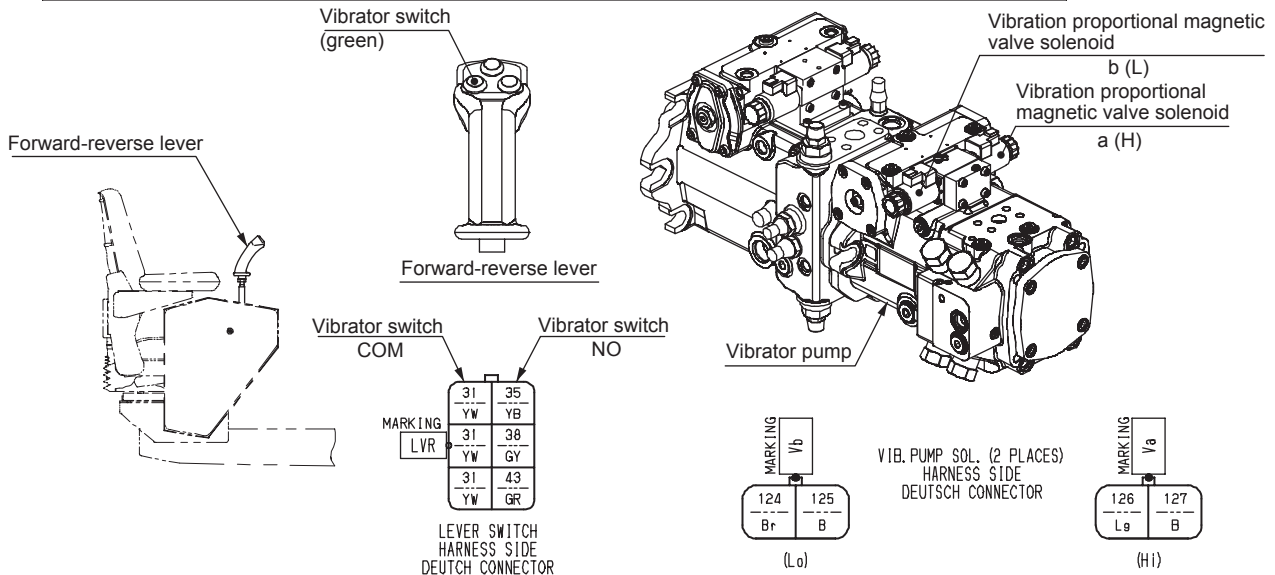
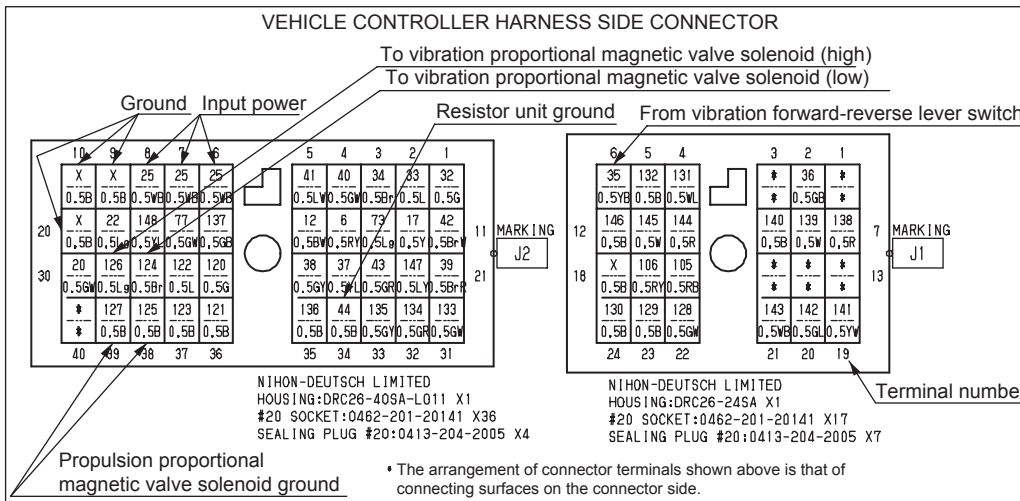
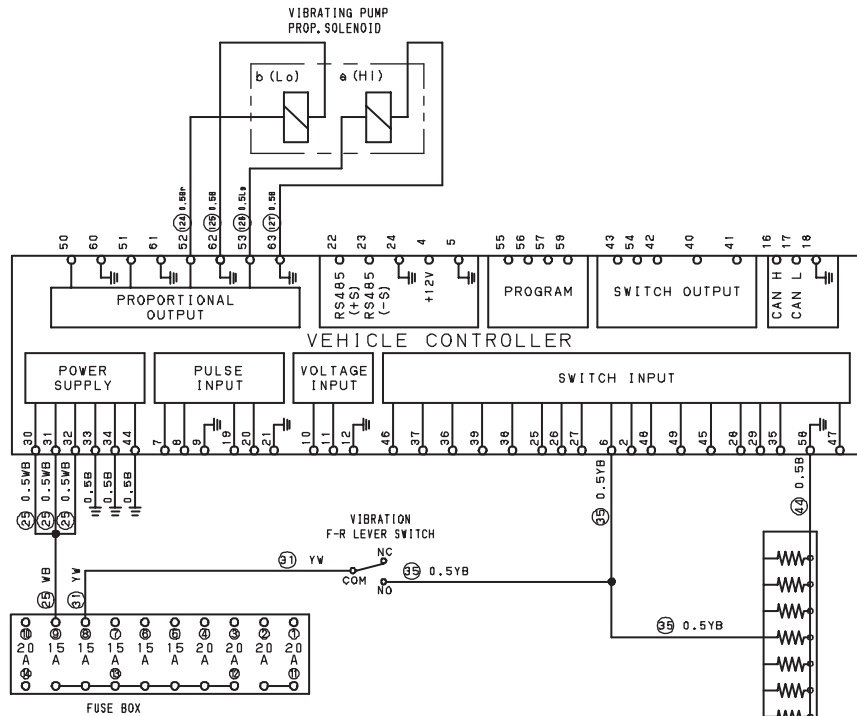

2-6. Vibration

Check the following items before troubleshooting.

- The fuses have not been blown and power is applied up to the fuses.
- When measuring voltage without disconnecting connectors, refer to the description of voltage measurement methods (P.11-006).

2-6-1. No vibration occurs (1/2)

- Check whether the display shows any error code.

Reference Fig. : 2-6-1

1) When the display shows any error code

- Set the vibration mode (continuous/automatic) selector switch to the continuous position.

Error code	Check point	Check/Cause	Action
E 33 or E 34	1. Connector	- Check the vibration forward-reverse lever switch connector and vehicle controller connector (pin 6) for corrosion, breakage, bending and looseness. - If any abnormality is found, the connector is faulty.	Replace the connector or terminal.
	2. Harness	(1) Measure the resistance between the vibration forward-reverse lever switch connector terminal YB wire and the vehicle controller connector pin 6 YB wire. Standard resistance: 10 Ω or less (2) Measure the resistance between the vibration forward-reverse lever switch connector terminal YW wire and the fuse box 8 input YW wire. Standard resistance: 10 Ω or less - If the resistance is abnormal, the harness is faulty.	Repair or replace the harness.
	3. Vibration Proportional Magnetic Valve Solenoid L or H	- Disconnect the harness of the vibration proportional magnetic valve solenoid L or H and measure the resistance of the coil. Standard resistance: 5.5 Ω - If the resistance is abnormal, the corresponding vibration proportional magnetic valve solenoid L or H is faulty.	Replace the vibration proportional magnetic valve solenoid L or H.
	4. Vehicle Controller	(1) When the starter switch is ON, measure the voltage between the vehicle controller input power supply pins 30, 31 and 32 and the ground pins 33, 34 and 44. Standard voltage: 12V or more (2) When the starter switch is ON, measure the voltage between the vehicle controller pin 6 (positive side) and the pin 58 (negative side) with the green button on the vibration forward-reverse lever switch pressed. Standard voltage: 12V - If the above items (1) and (2) are OK, the vehicle controller is faulty.	Replace the vehicle controller.

Fig. : 2-6-2

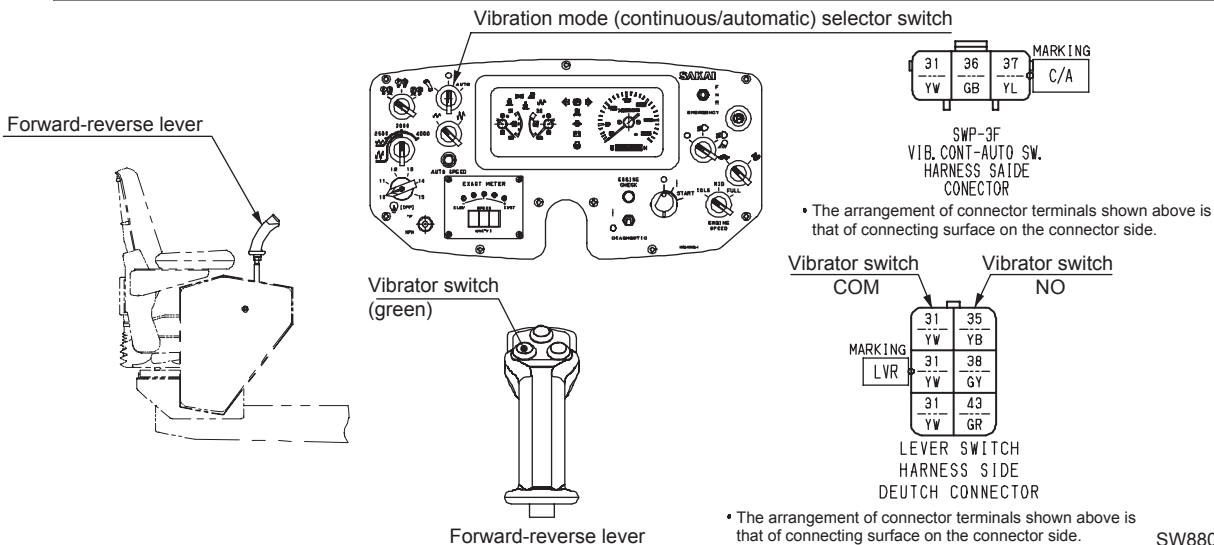
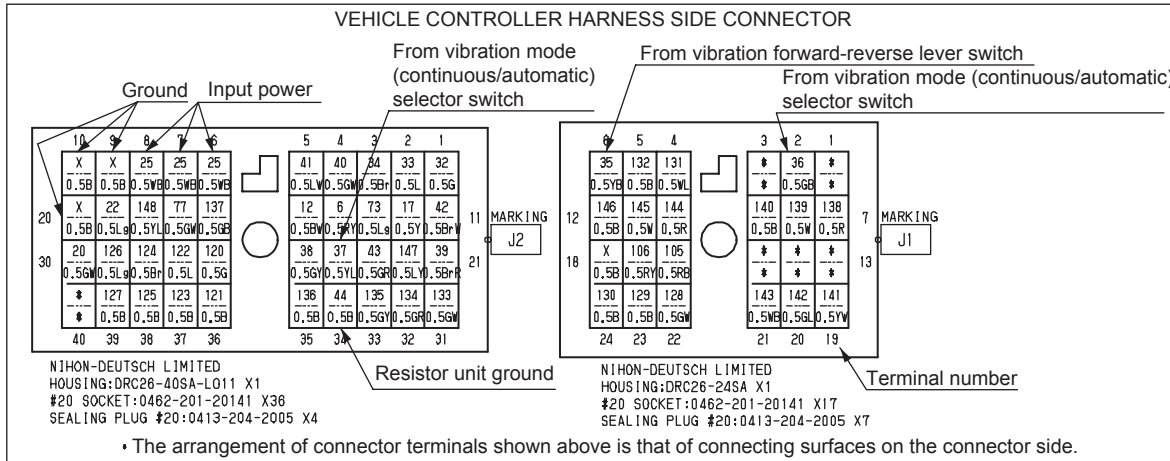
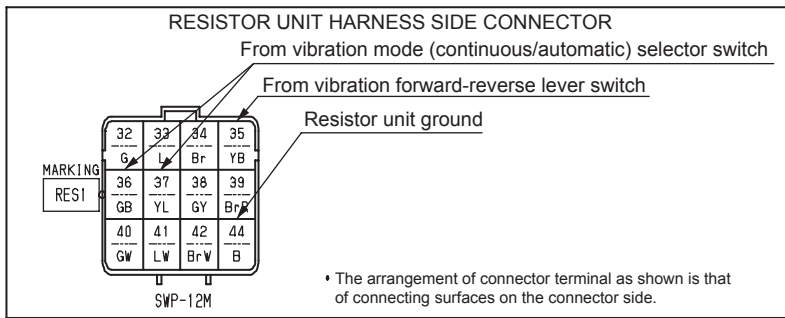
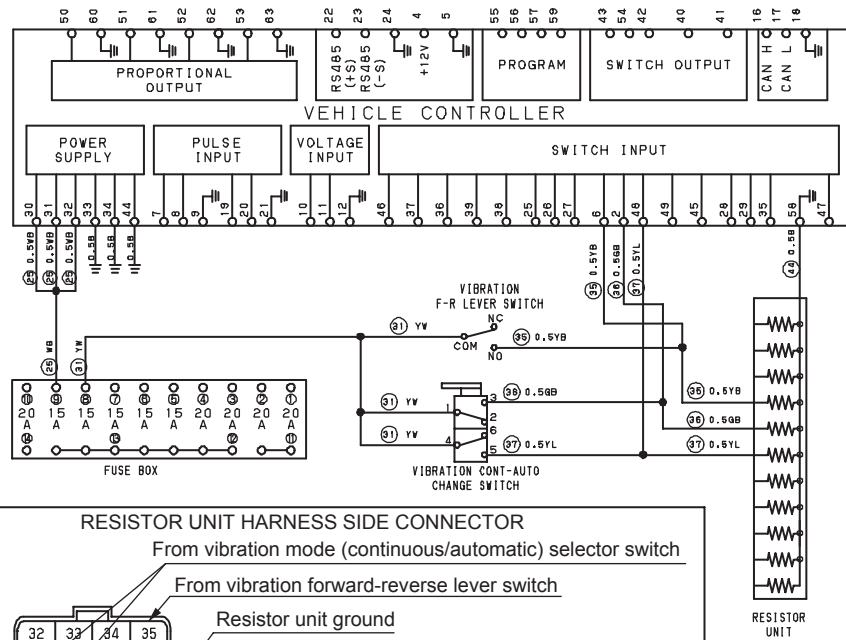

2-6-1. No vibration occurs (2/2)

- Check whether the display shows any error code.

Reference Fig. : 2-6-2

2) When the display shows no error code

- Set the vibration mode (continuous/automatic) selector switch to the continuous position.

Check point	Check/Cause	Action
1. Vibration Mode (Continuous/Automatic) Selector Switch	<p>(1) When the starter switch is ON and the vibration mode (continuous/automatic) selector switch is set to the continuous position, measure the voltage between the vibration mode (continuous/automatic) selector switch pin 1 or 4 inlet YW wire and the chassis ground. Standard voltage: 12V</p> <p>(2) When the starter switch is ON and the vibration mode (continuous/automatic) selector switch is set to the continuous position, measure the voltage between the vibration mode (continuous/automatic) selector switch pin 3 inlet GB wire or pin 5 inlet YL wire and the chassis ground. There is no current in the normal condition.</p> <ul style="list-style-type: none"> - If the above item (1) is OK and current is found in the item (2), the vibration mode (continuous/automatic) selector switch is faulty. 	Replace the vibration mode (continuous/automatic) selector switch.
2. Vibration Forward-Reverse Lever Switch	<ul style="list-style-type: none"> - Check the continuity between the vibration forward-reverse lever switch COM terminal YW wire and the NO terminal YB wire with the green button on the vibration forward-reverse lever switch pressed. - There is continuity in the normal condition. If there is no continuity, the vibration forward-reverse lever switch is faulty. <p>(NOTICE)</p> <ul style="list-style-type: none"> • Pressing the green button on the vibration forward-reverse lever switch turns on the vibration and the vibration is turned off when the switch is pressed again. 	Replace the vibration forward-reverse lever switch.
3. Resistor Unit	<ul style="list-style-type: none"> - Measure the resistance between the resistor unit terminal inlet YB wire 35 and the B wire 44. Standard resistance: 300 Ω - If the resistance is abnormal, the resistor unit is faulty. <p>(NOTICE)</p> <ul style="list-style-type: none"> • The resistor unit is used to stabilize the contact of the switch. 	Replace the resistor unit.
4. Vehicle Controller	<ul style="list-style-type: none"> - When the starter switch is ON, measure the voltage between the vehicle controller pin 6 YB wire and the pin 58 B wire with the green button on the vibration forward-reverse lever switch pressed. Standard voltage: 12V or more - If the display shows no error code and the above item is OK, the vehicle controller is faulty. 	Replace the vehicle controller.
5. Harness Connecting Between Terminals	<ul style="list-style-type: none"> - Measure the resistance of the harness connecting between terminals. Standard resistance: 10 Ω or less - If the resistance is abnormal, the harness is faulty. 	Repair or replace the harness.

Fig. : 2-6-3

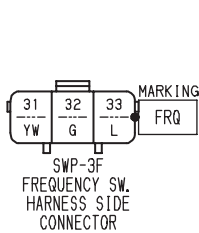
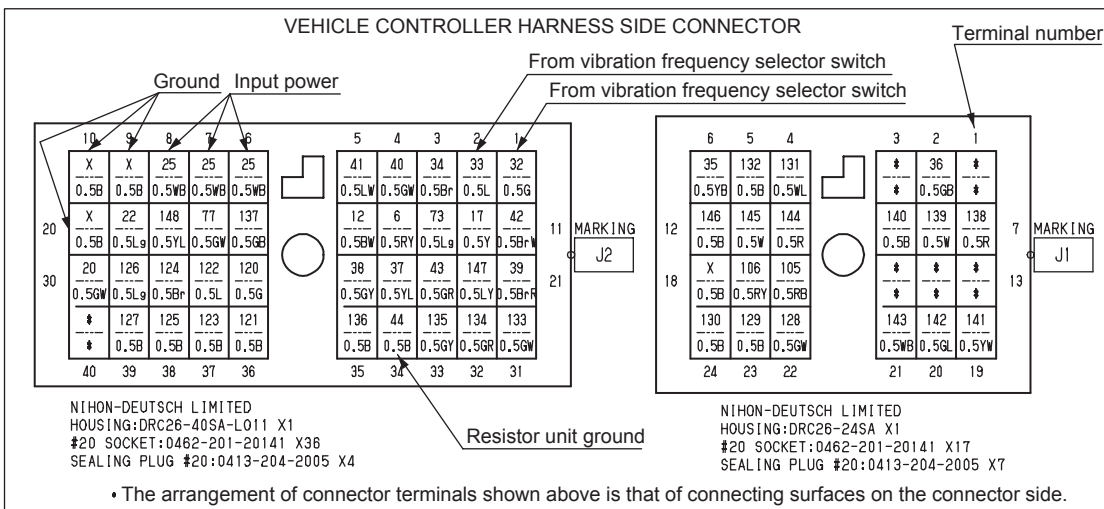
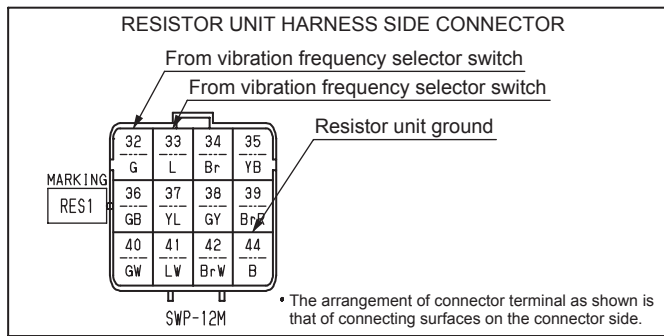
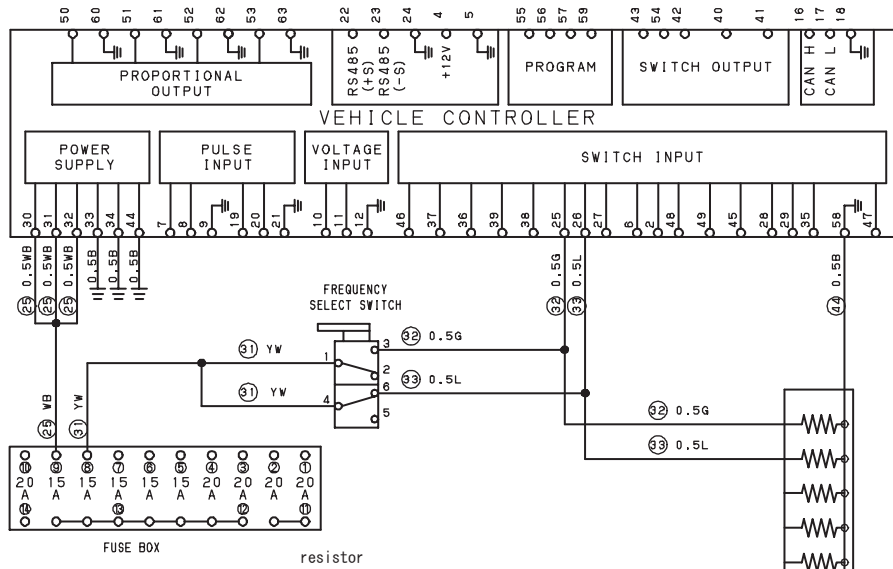

• The arrangement of connector terminals shown above is that of connecting surface on the connector side.

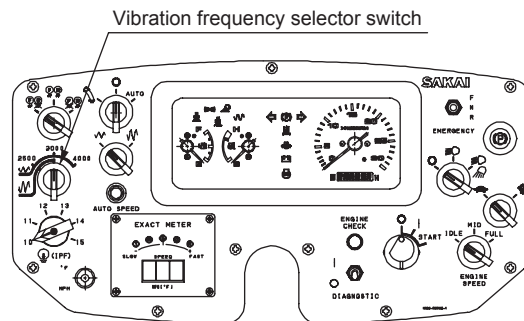

2-6-2. Vibration frequency cannot be switched (1/2)

- Set the vibration mode (continuous/automatic) selector switch to the continuous position.
- If the frequency cannot be switched, it will be fixed at 4,000 vpm of the low mode.

Reference Fig. : 2-6-3

Error code	Check point	Check/Cause	Action
E 21	1. Connector	<ul style="list-style-type: none"> - Check the vibration frequency selector switch connector and vehicle controller connector (pins 25 and 26) for corrosion, breakage, bending and looseness. - If any abnormality is found, the connector is faulty. 	Replace the connector or terminal.
	2. Harness	<p>(1) Measure the resistance between the vibration frequency selector switch connector terminal G and L wires and the vehicle controller connector pin 25 G wire and pin 26 L wire. Standard resistance: 10 Ω or less</p> <p>(2) Measure the resistance between the vibration frequency selector switch connector terminal YW wire and the fuse box 8 input YW wire. Standard resistance: 10 Ω or less</p> <ul style="list-style-type: none"> - If the resistance is abnormal, the harness is faulty. 	Repair or replace the harness.
	3. Vibration Frequency Selector Switch	<p>(1) When the starter switch is ON, measure the voltage between the vibration frequency selector switch pins 1 and 4 inlet YW wires and the chassis ground. Standard voltage: 12V or more</p> <p>(2) When the starter switch is ON and the vibration frequency selector switch is set to 2,500 vpm, measure the voltage between the vibration frequency selector switch pin 6 inlet L wire and the chassis ground. Standard voltage: 12V or more</p> <p>(3) When the starter switch is ON and the vibration frequency selector switch is set to 3,000 vpm, measure the voltage between the vibration frequency selector switch pin 3 inlet G wire and pin 6 inlet L wire and the chassis ground. Standard voltage: 12V or more</p> <p>(4) When the starter switch is ON and the vibration frequency selector switch is set to 4,000 vpm, measure the voltage between the vibration frequency selector switch pin 3 inlet G wire and the chassis ground. Standard voltage: 12V or more</p> <ul style="list-style-type: none"> - If the above item (1) is OK and any of the items (2) through (4) is NG, the vibration frequency selector switch is faulty. 	Replace the vibration frequency selector switch.
	4. Resistor Unit	<p>(1) Measure the resistance between the resistor unit terminal inlet G wire 32 and the B wire 44. Standard resistance: 300 Ω</p> <p>(2) Measure the resistance between the resistor unit terminal inlet L wire 33 and the B wire 44. Standard resistance: 300 Ω</p> <ul style="list-style-type: none"> - If the above item (1) or (2) is NG, the resistor unit is faulty. <p>(NOTICE)</p> <ul style="list-style-type: none"> • The resistor unit is used to stabilize the contact of the switch. 	Replace the resistor unit.

2-6-2. Vibration frequency cannot be switched (2/2)

- Set the vibration mode (continuous/automatic) selector switch to the continuous position.
- If the frequency cannot be switched, it will be fixed at 4000 vpm of the low mode.

Reference Fig. : 2-6-3

Error code	Check point	Check/Cause	Action
E 21	5. Vehicle Controller	<p>(1) When the starter switch is ON, measure the voltage between the vehicle controller input power supply pins 30, 31 and 32 and the ground pins 33, 34 and 44. Standard voltage: 12V or more</p> <p>(2) When the starter switch is ON and the vibration frequency selector switch is set to 2,500 vpm, measure the voltage between the vehicle controller pin 26 L wire and the pin 58 B wire. Standard voltage: 12V or more</p> <p>(3) When the starter switch is ON and the vibration frequency selector switch is set to 3,000 vpm, measure the voltage between the vehicle controller pin 25 G wire and pin 26 L wire and the pin 58 B wire. Standard voltage: 12V or more</p> <p>(4) When the starter switch is ON and the vibration frequency selector switch is set to 4,000 vpm, measure the voltage between the vehicle controller pin 25 G wire and the pin 58 B wire. Standard voltage: 12V or more</p> <p>- If the above items (1), (2), (3) and (4) are OK, the vehicle controller is faulty.</p>	Replace the vehicle controller.

Fig. : 2-6-4

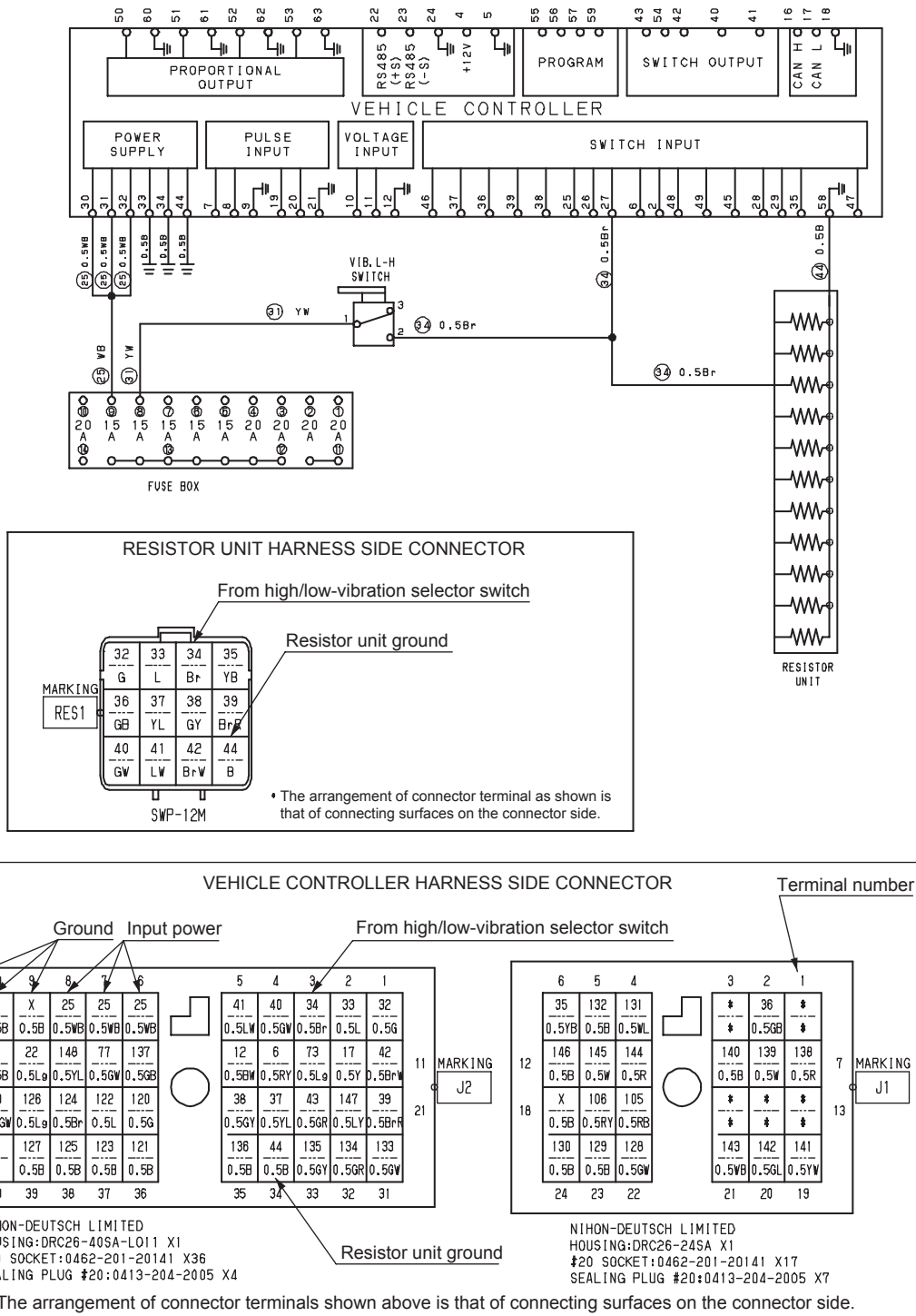

2-6-3. High/low-vibration cannot be switched

- Set the vibration mode (continuous/automatic) selector switch to the continuous position.

Reference Fig. : 2-6-4

Check point	Check/Cause	Action
1. High/low-vibration Selector Switch	<p>(1) When the starter switch is ON and the high/low-vibration selector switch is in the high position, measure the voltage between the high/low-vibration selector switch pin 1 YW wire and the chassis ground. Standard voltage: 12V</p> <p>(2) When the starter switch is ON and the high/low-vibration selector switch is in the high position, measure the voltage between the high/low-vibration selector switch pin 2 Br wire and the chassis ground. Standard voltage: 12V</p> <p>- If the above item (1) is OK and no current is found in the item (2), the high/low-vibration selector switch is faulty.</p>	Replace the high/low-vibration selector switch.
2. Resistor Unit	<p>- Measure the resistance between the resistor unit terminal inlet Br wire 34 and the B wire 44. Standard resistance: 300 Ω</p> <p>- If the resistance is abnormal, the resistor unit is faulty.</p> <p>(NOTICE)</p> <ul style="list-style-type: none"> • The resistor unit is used to stabilize the contact of the switch. 	Replace the resistor unit.
3. Vehicle Controller	<p>(1) When the starter switch is ON, measure the voltage between the vehicle controller input power supply pins 30, 31 and 32 and the ground pins 33, 34 and 44. Standard voltage: 12V or more</p> <p>(2) When the starter switch is ON and the high/low-vibration selector switch is in the high position, measure the voltage between the vehicle controller pin 27 Br wire and the pin 58 B wire. Standard voltage: 12V or more</p> <p>- If the above items (1) and (2) are OK, the vehicle controller is faulty.</p>	Replace the vehicle controller.
4. Harness Connecting Between Terminals	<p>- Measure the resistance of the harness connecting between terminals. Standard resistance: 10 Ω or less</p> <p>- If the resistance is abnormal, the harness is faulty.</p>	Repair or replace the harness.

Fig. : 2-6-5

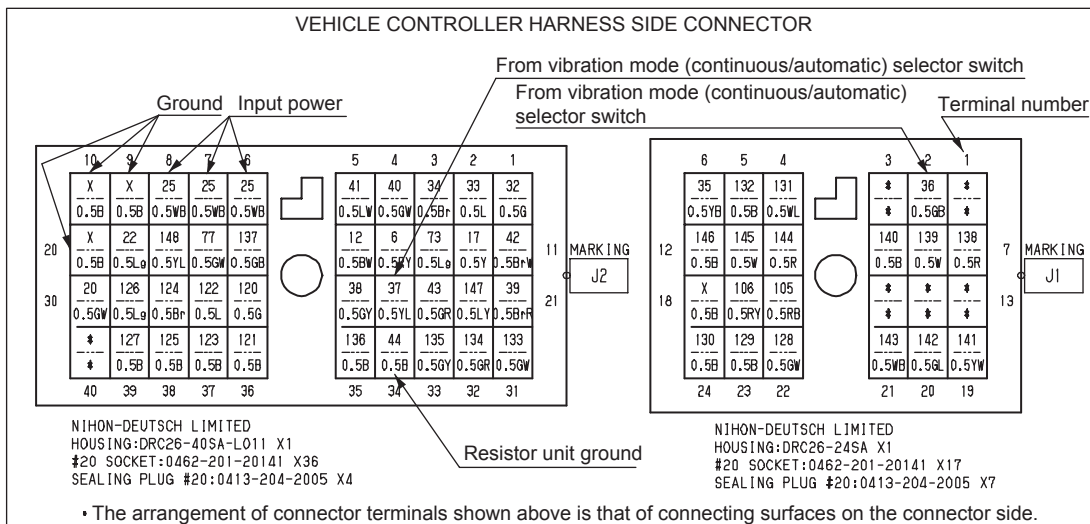
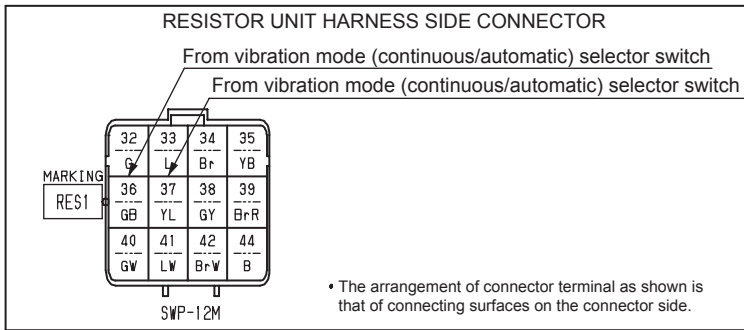
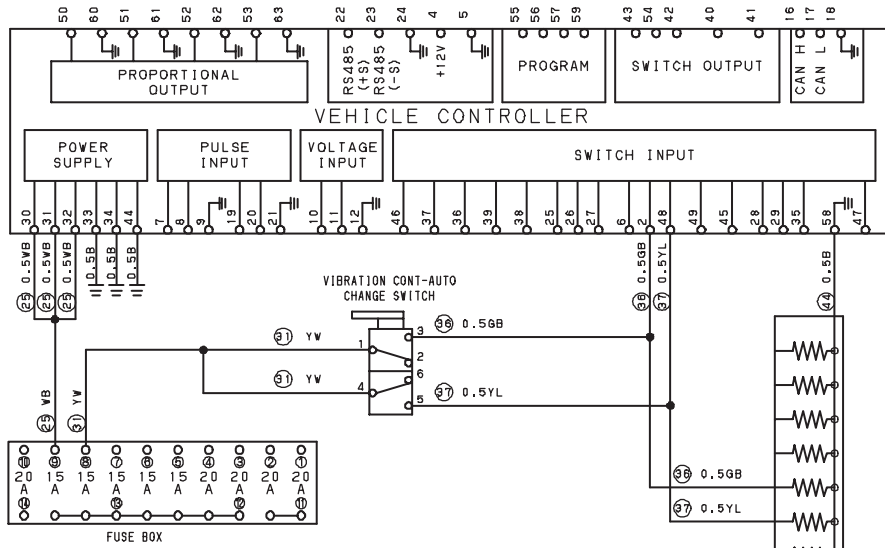

Vibration mode (continuous/automatic) selector switch

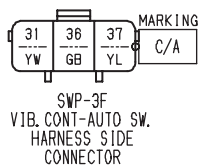

• The arrangement of connector terminals shown above is that of connecting surface on the connector side.

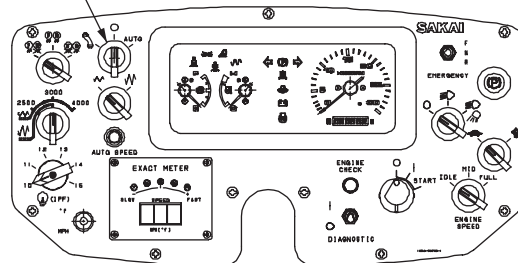

2-6-4. Continuous/automatic-vibration mode cannot be switched

Reference Fig. : 2-6-5

Check point	Check/Cause	Action
1. Vibration Mode (Continuous/Automatic) Selector Switch	<p>(1) When the starter switch is ON and the vibration mode (continuous/automatic) selector switch is set to the continuous position, measure the voltage between the vibration mode (continuous/automatic) selector switch pins 1 and 4 YW wires and the chassis ground. Standard voltage: 12V</p> <p>(2) When the starter switch is ON and the vibration mode (continuous/automatic) selector switch is set to the continuous position, measure the voltage between the vibration mode (continuous/automatic) selector switch pin 3 GB wire and pin 5 YL wire and the chassis ground. There is no current in the normal condition.</p> <p>(3) When the starter switch is ON and the vibration mode (continuous/automatic) selector switch is set to the automatic position, measure the voltage between the vibration mode (continuous/automatic) selector switch pin 3 GB wire and pin 5 YL wire and the chassis ground. Standard voltage: 12V</p> <p>- If the above item (1) is OK and the item (2) or (3) is NG, the vibration mode (continuous/automatic) selector switch is faulty.</p>	Replace the vibration mode (continuous/automatic) selector switch.
2. Resistor Unit	<p>- Measure the resistance between the resistor unit terminal inlet GB wire 36 and YL wire 37 and the B wire 44. Standard resistance: 300 Ω</p> <p>- If the resistance is abnormal, the resistor unit is faulty.</p> <p>(NOTICE)</p> <ul style="list-style-type: none"> • The resistor unit is used to stabilize the contact of the switch. 	Replace the resistor unit.
3. Vehicle Controller	<p>(1) When the starter switch is ON, measure the voltage between the vehicle controller input power supply pins 30, 31 and 32 and the ground pins 33, 34 and 44. Standard voltage: 12V or more</p> <p>(2) When the starter switch is ON and the vibration mode (continuous/automatic) selector switch is in the continuous position, measure the voltage between the vehicle controller pin 2 GB wire and pin 48 YL wire and the pin 58 B wire. There is no current in the normal condition.</p> <p>(3) When the starter switch is ON and the vibration mode (continuous/automatic) selector switch is in the automatic position, measure the voltage between the vehicle controller pin 2 GB wire and pin 48 YL wire and the pin 58 B wire. Standard voltage: 12V or more</p> <p>- If the above item (1) is OK and the item (2) or (3) is NG, the vehicle controller is faulty.</p>	Replace the vehicle controller.
4. Harness Connecting Between Terminals	<p>- Measure the resistance of the harness connecting between terminals. Standard resistance: 10 Ω or less</p> <p>- If the resistance is abnormal, the harness is faulty.</p>	Repair or replace the harness.

Fig. : 2-6-6

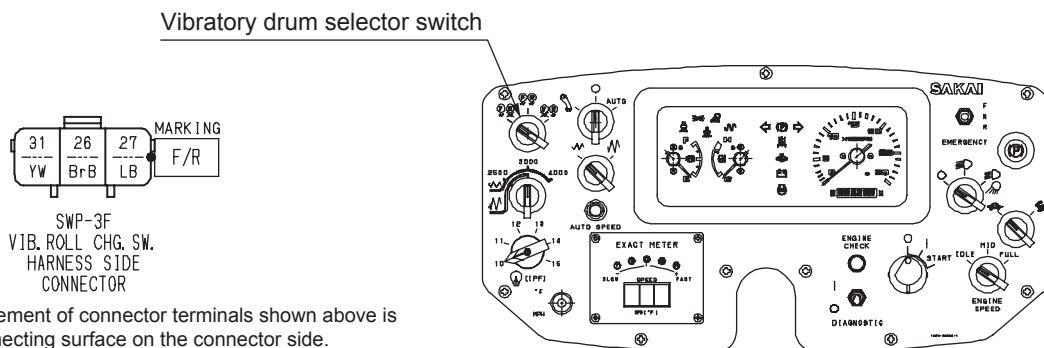
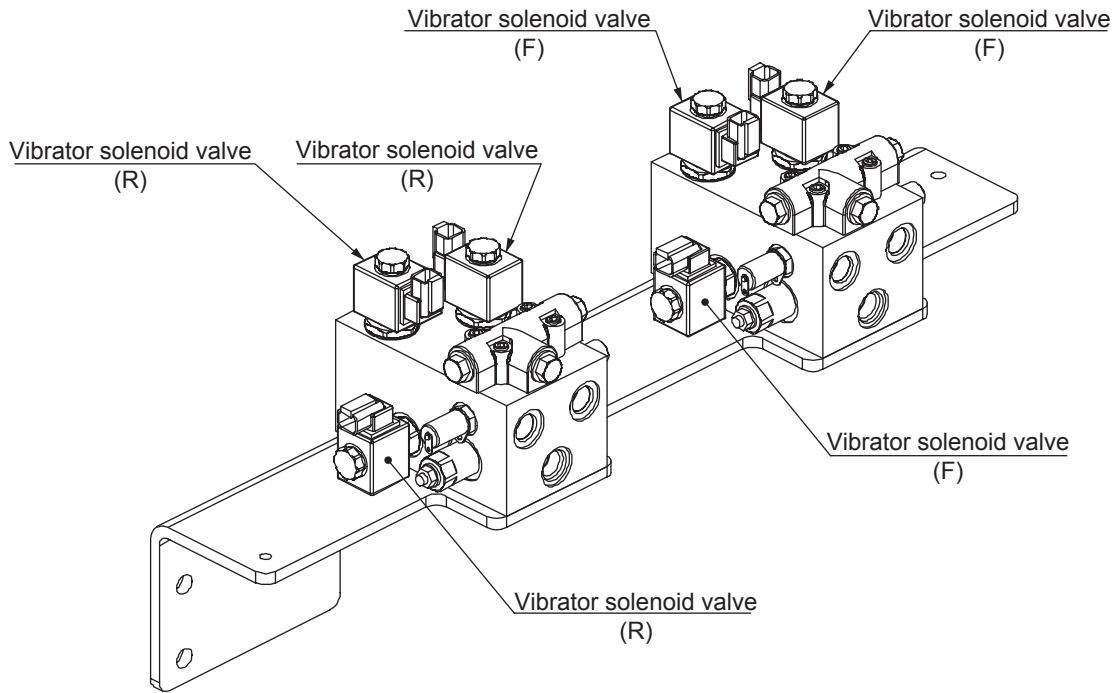
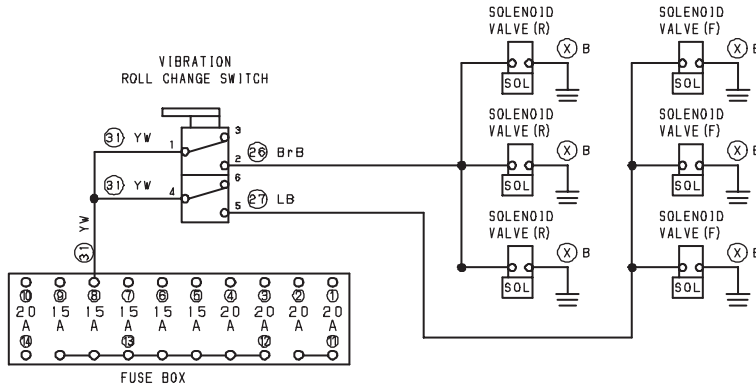

• The arrangement of connector terminals shown above is that of connecting surface on the connector side.

2-6-5. Front and rear vibratory drums cannot perform one-drum vibration**Reference Fig. : 2-6-6**

Check point	Check/Cause	Action
1. Vibrator Solenoid (3 each for front and rear)	<ul style="list-style-type: none"> - Disconnect each harness of the vibrator solenoids (3 each for front and rear) in the front or rear drum and measure the resistance of the coil. Standard resistance: 7.2 Ω - If the resistance is abnormal, the vibrator solenoid is faulty. 	Replace the vibrator solenoid.
2. Vibratory Drum Selector Switch	<ul style="list-style-type: none"> (1) When the starter switch is ON and the vibratory drum selector switch is set to the two-drum vibration position, measure the voltage between the vibratory drum selector switch pins 1 and 4 YW wires and each chassis ground. Standard voltage: 12V (2) When the starter switch is ON and the vibratory drum selector switch is set to the two-drum vibration position, measure the voltage between the vibratory drum selector switch pin 2 BrB wire and pin 5 LB wire and each chassis ground. There is no current in the normal condition. (3) When the starter switch is ON and the vibratory drum selector switch is set to the front drum vibration position, measure the voltage between the vibratory drum selector switch pin 2 BrB wire and the chassis ground. Standard voltage: 12V (4) When the starter switch is ON and the vibratory drum selector switch is set to the rear drum vibration position, measure the voltage between the vibratory drum selector switch pin 5 LB wire and the chassis ground. Standard voltage: 12V - If the above item (1) is OK and any of the items (2) through (4) is NG, the vibratory drum selector switch is faulty. 	Replace the vibratory drum selector switch.
3. Harness Connecting Between Terminals	<ul style="list-style-type: none"> - Measure the resistance of the harness connecting between terminals. Standard resistance: 10 Ω or less - If the resistance is abnormal, the harness is faulty. 	Repair or replace the harness.

Fig. : 2-5-5

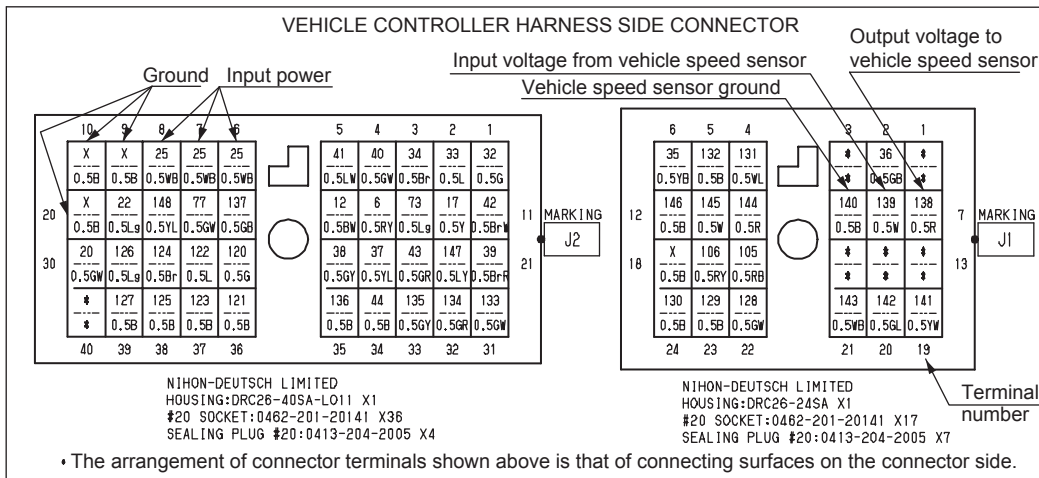
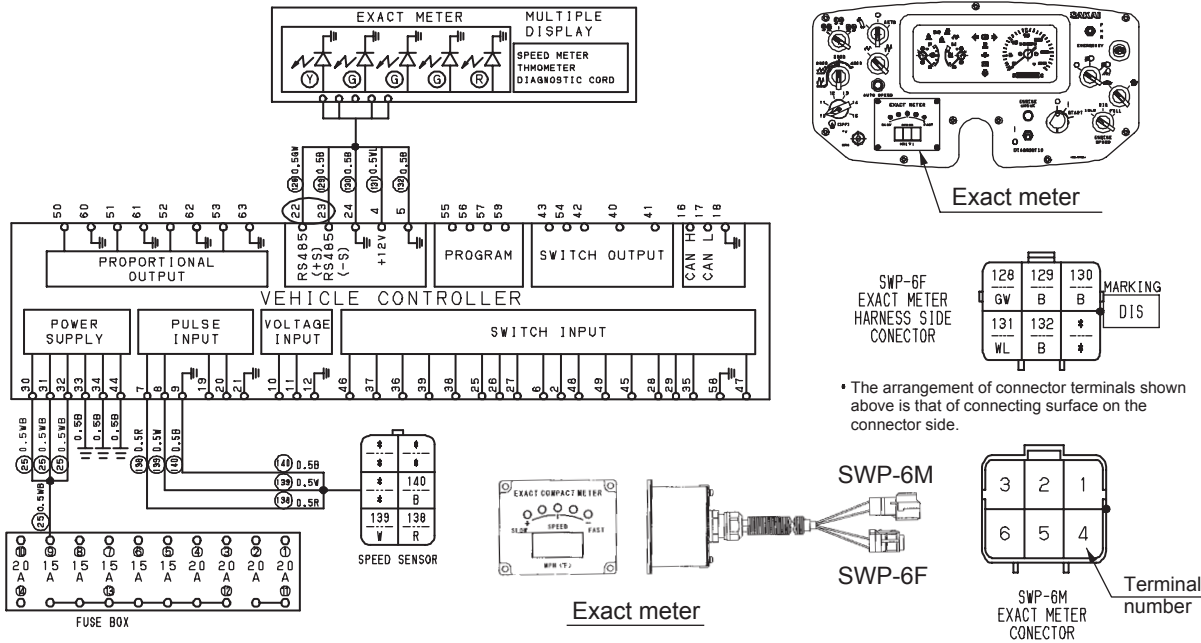

Vehicle speed sensor specifications

- Supply power voltage 5V ± 0.25
- Maximum required current 25mA
- Output signal 21 pulses/rev.
- Connector DEUTSCH DTM-Series 6-Pin DTM 04-6P

Sensor pin I/O	
1	Output signal 2
2	Revolving direction output
3	Output signal 1
4	Supply power voltage
5	0 V (GND)
6	-

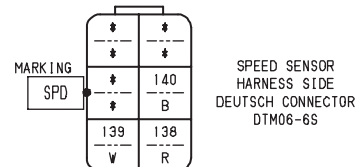
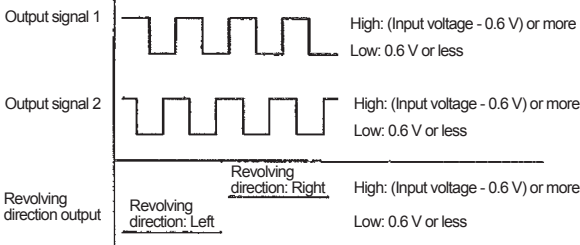
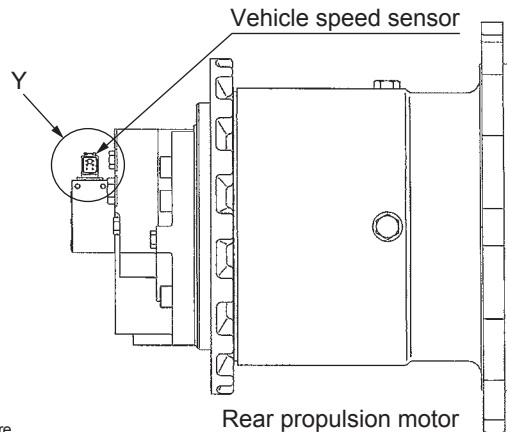

• The arrangement of connector terminals shown above is that of connecting surface on the connector side.

2-7. Exact Meter

Check the following item before troubleshooting.

- No fuse has been blown.

(NOTICE)

- **If any abnormality is found in the shielded twisted wires, be sure to replace them.**

2-7-1. Exact meter indicator lamp does not illuminate (during driving) (1/2)

- The exact meter indicator lamp illuminates only while the vibration is activated.

Reference Fig. : 2-5-5

1) When the display shows any error code

Error code	Check point	Check/Cause	Action
E 11	1. Connector	- Check the speed sensor connector and vehicle controller connector (pins 7, 8 and 9) for corrosion, breakage, bending and looseness. - If any abnormality is found, the connector is faulty.	Replace the connector or terminal.
	2. Harness	- Measure the resistance between the speed sensor connector terminal R, W and B wires and the vehicle controller connector pins 7 R wire, pin 8 W wire and pin 9 B wire. Standard resistance: 10 Ω or less - If the resistance is abnormal, the harness is faulty.	Repair or replace the harness.
	3. Speed Sensor	(1) When the starter switch is ON, measure the voltage between the speed sensor input terminal R wire and the exact meter ground terminal B wire. Standard voltage: 5V (2) Start the engine and measure the pulse between the speed sensor terminal W wire and the speed sensor ground terminal B wire with a pulse meter with the vibratory drum rotating. Standard pulse: 21 pulses/rotation - If the above item (1) is OK and the item (2) is NG, the speed sensor is faulty.	Replace the speed sensor.
	4. Vehicle Controller	- If the error code E 11 is displayed and no abnormality is found in the connector, harness and speed sensor in the above inspections, the vehicle controller is faulty.	Replace the vehicle controller.
E 42	5. RS485 Communication (Serial Communication)	- Faulty RS485 (serial) communication (NOTICE) • The vehicle controller on the transmission side or the multiple display is faulty.	Replace the vehicle controller or multiple display.

Fig. : 2-5-5

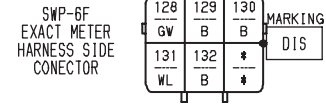
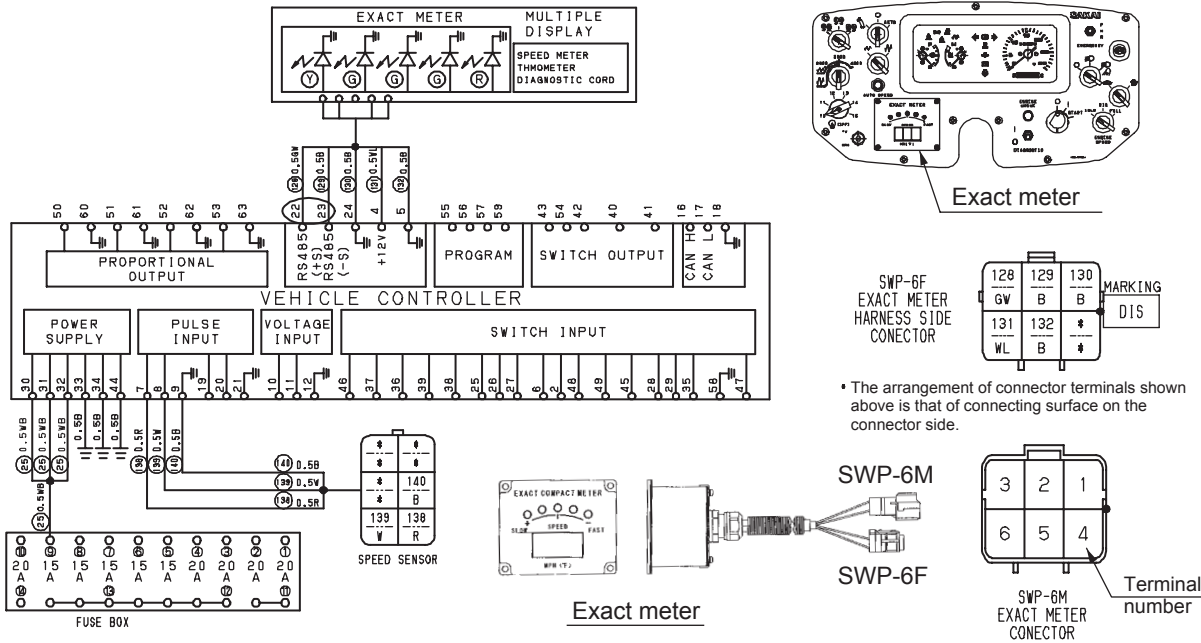

The arrangement of connector terminals shown above is that of connecting surface on the connector side.

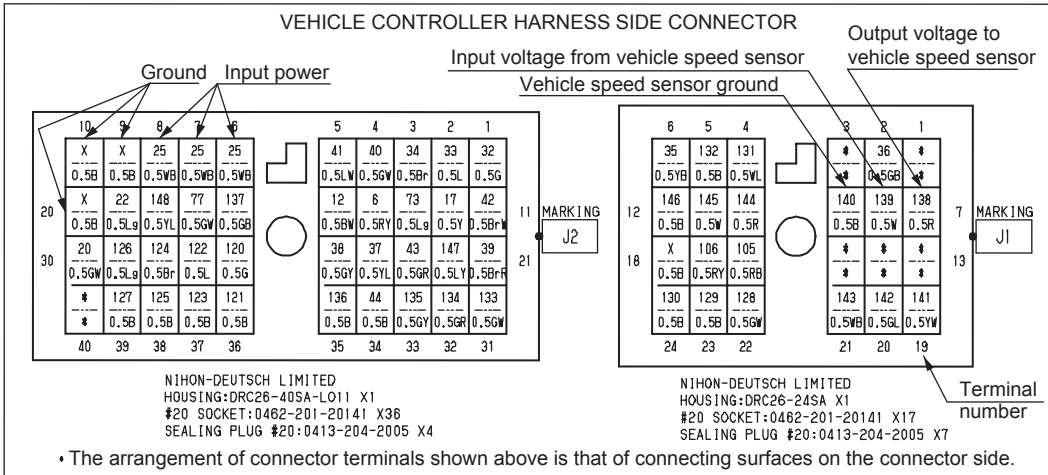
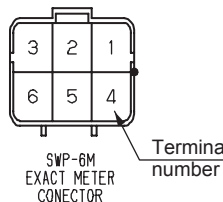

The arrangement of connector terminals shown above is that of connecting surfaces on the connector side.

Vehicle speed sensor specifications

- Supply power voltage 5V ± 0.25
- Maximum required current 25mA
- Output signal 21 pulses/rev.
- Connector DEUTSCH DTM-Series 6-Pin DTM 04-6P

Sensor pin I/O	
1	Output signal 2
2	Revolving direction output
3	Output signal 1
4	Supply power voltage
5	0 V (GND)
6	-

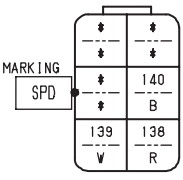
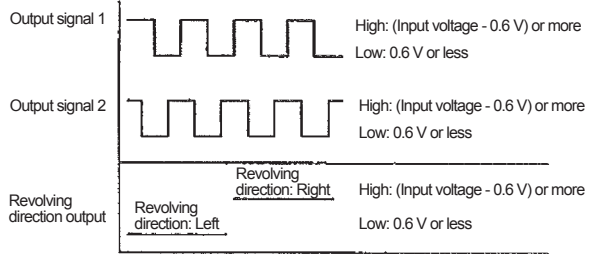
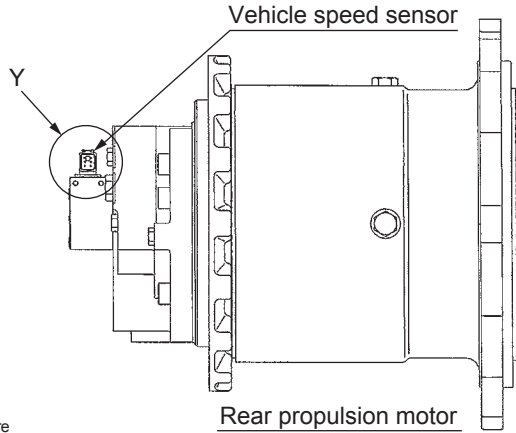

The arrangement of connector terminals shown above is that of connecting surface on the connector side.

2-7-1. Exact meter indicator lamp does not illuminate (during driving) (2/2)

- The exact meter indicator lamp illuminates only while the vibration is activated.

Reference Fig. : 2-5-5

2) When the display shows no error code

Check point	Check/Cause	Action
1. Connector	<ul style="list-style-type: none"> - Check the vehicle controller connector (pins 22, 23, 24, 4 and 5) and the multiple display connectors (connectors 1, 2, 3, 4 and 5) for corrosion, breakage, bending and looseness. - If any abnormality is found, the connector is faulty. 	Replace the connector or terminal.
2. Harness	<ul style="list-style-type: none"> - Measure the resistance between the vehicle controller connector pin 22 GW wire, pin 23 B wire, pin 24 B wire, pin 4 WL wire and pin 5 B wire and the multiple display connector pin 1 GW wire, pin 2 B wire, pin 3 B wire, pin 4 WL wire and pin 5 B wire respectively. Standard resistance: 10 Ω or less - If the resistance is abnormal, the harness is faulty. <p>(NOTICE)</p> <ul style="list-style-type: none"> • Since shielded twisted wires are used for the vehicle controller terminal harness, repair is not approved. Be sure to replace them. 	Replace the harness.
3. Multiple Display	<ul style="list-style-type: none"> - If no abnormality is found in the connector and harness in the above inspections and the error code E 42 is not displayed, the multiple display or vehicle controller is faulty. 	Replace the multiple display or vehicle controller.

Fig. : 2-5-5

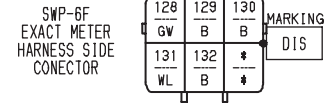
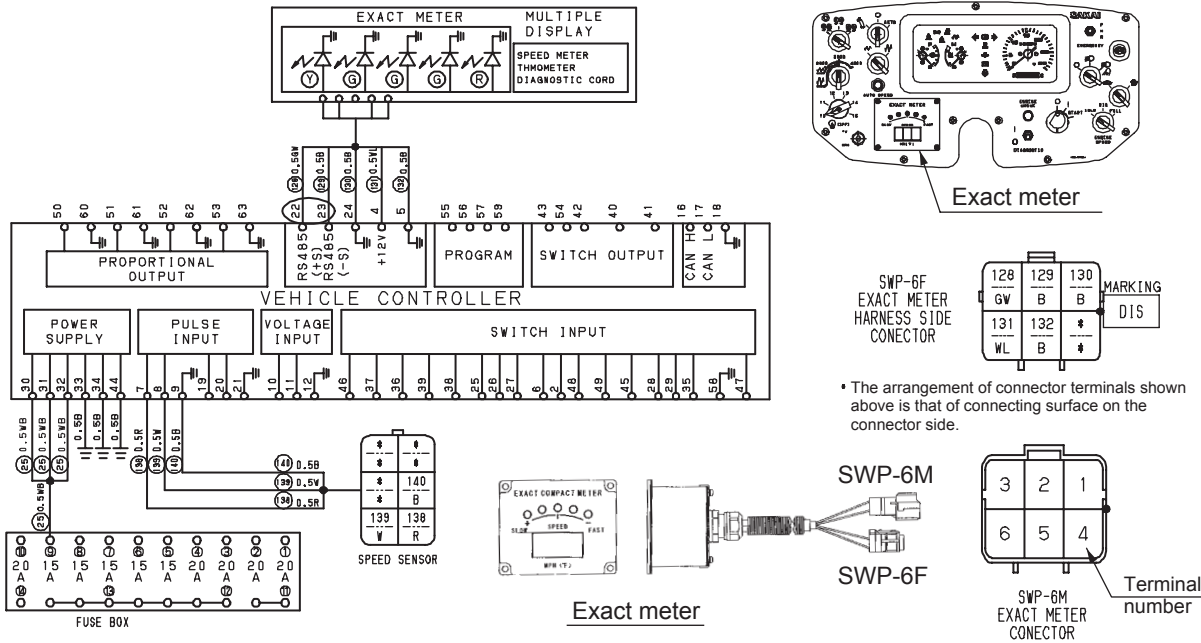

• The arrangement of connector terminals shown above is that of connecting surface on the connector side.

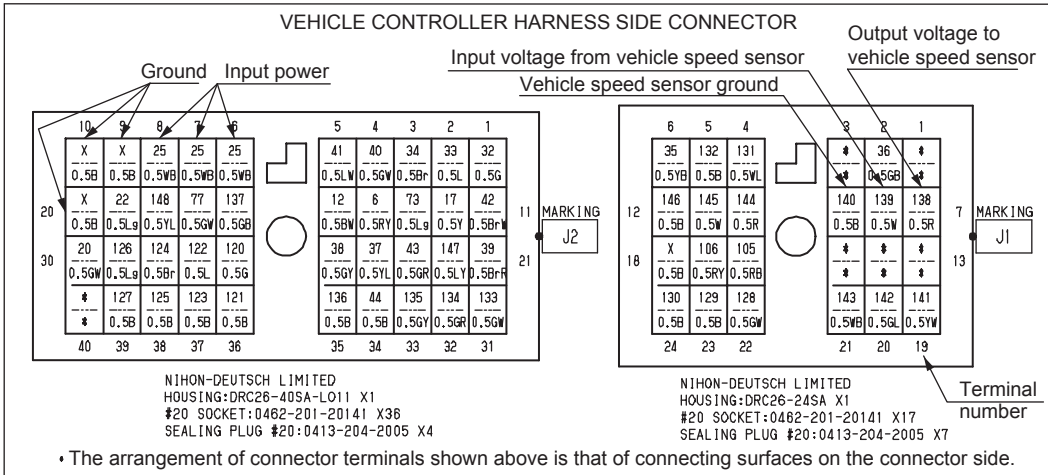
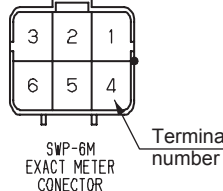

• The arrangement of connector terminals shown above is that of connecting surfaces on the connector side.

Vehicle speed sensor specifications

- Supply power voltage: 5V ± 0.25
- Maximum required current: 25mA
- Output signal: 21 pulses/rev.
- Connector: DEUTSCH DTM-Series 6-Pin DTM 04-6P

Sensor pin I/O	
1	Output signal 2
2	Revolving direction output
3	Output signal 1
4	Supply power voltage
5	0 V (GND)
6	-

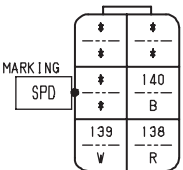
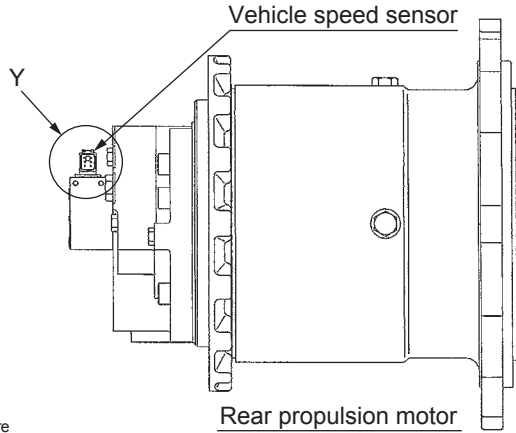

• The arrangement of connector terminals shown above is that of connecting surface on the connector side.

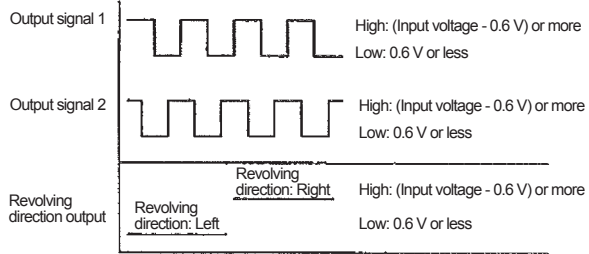

2-7-2. No vehicle speed indication on the display

Reference Fig. : 2-5-5

1) When the display shows any error code

Error code	Check point	Check/Cause	Action
E 11	1. Connector	- Check the speed sensor connector and vehicle controller connector (pins 7, 8 and 9) for corrosion, breakage, bending and looseness. - If any abnormality is found, the connector is faulty.	Replace the connector or terminal.
	2. Harness	- Measure the resistance between the speed sensor connector terminal R, W and B wires and the vehicle controller connector pin 7 R wire, pin 8 W wire and pin 9 B wire respectively. Standard resistance: 10 Ω or less - If the resistance is abnormal, the harness is faulty.	Repair or replace the harness.
	3. Speed Sensor	(1) When the starter switch is ON, measure the voltage between the speed sensor input terminal R wire and the exact meter ground terminal B wire. Standard voltage: 5V (2) Start the engine and measure the pulse between the speed sensor terminal W wire and the speed sensor ground terminal B wire with a pulse meter with the drum rotating. Standard pulse: 21 pulses/rotation - If the above item (1) is OK and the item (2) is NG, the speed sensor is faulty.	Replace the speed sensor.
	4. Vehicle Controller	- If the error code E 11 is displayed and no abnormality is found in the connector, harness and speed sensor in the above inspections, the vehicle controller is faulty.	Replace the vehicle controller.
E 42	5. RS485 Communication (Serial Communication)	- Faulty RS485 (serial) communication (NOTICE) • The vehicle controller on the transmission side or the multiple display is faulty.	Replace the vehicle controller or multiple display.

2) When the display shows no error code

Check point	Check/Cause	Action
1. Connector	- Check the vehicle controller connector (pins 22, 23, 24, 4 and 5) and the multiple display connectors (connectors 1, 2, 3, 4 and 5) for corrosion, breakage, bending and looseness. - If any abnormality is found, the connector is faulty.	Replace the connector or terminal.
2. Harness	- Measure the resistance between the vehicle controller connector pin 22 GW wire, pin 23 B wire, pin 24 B wire, pin 4 WL wire and pin 5 B wire and the multiple display connector pin 1 GW wire, pin 2 B wire, pin 3 B wire, pin 4 WL wire and pin 5 B wire respectively. Standard resistance: 10 Ω or less - If the resistance is abnormal, the harness is faulty. (NOTICE) • Since shielded twisted wires are used for the vehicle controller terminal harness, repair is not approved. Be sure to replace them.	Replace the harness.
3. Multiple Display	- If no abnormality is found in the connector and harness in the above inspections and the error code E 42 is not displayed, the multiple display or vehicle controller is faulty.	Replace the multiple display or vehicle controller.

Fig. : 2-8-1

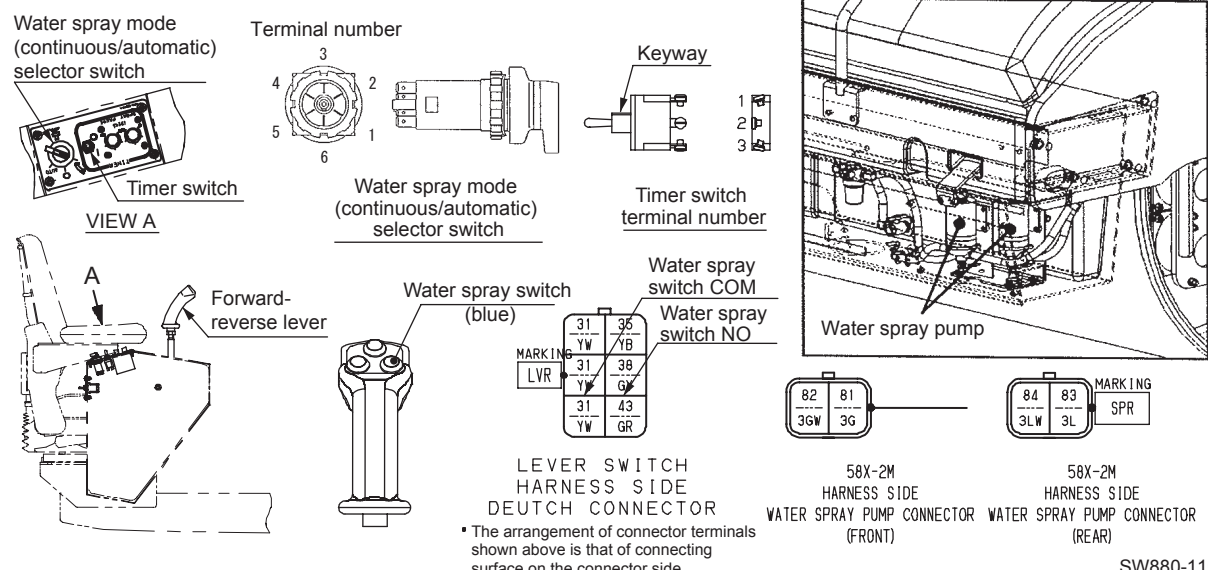
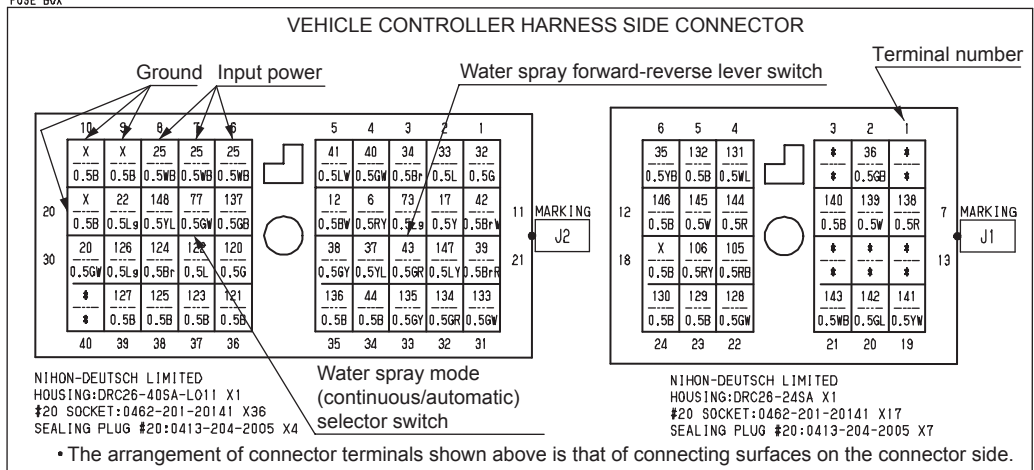
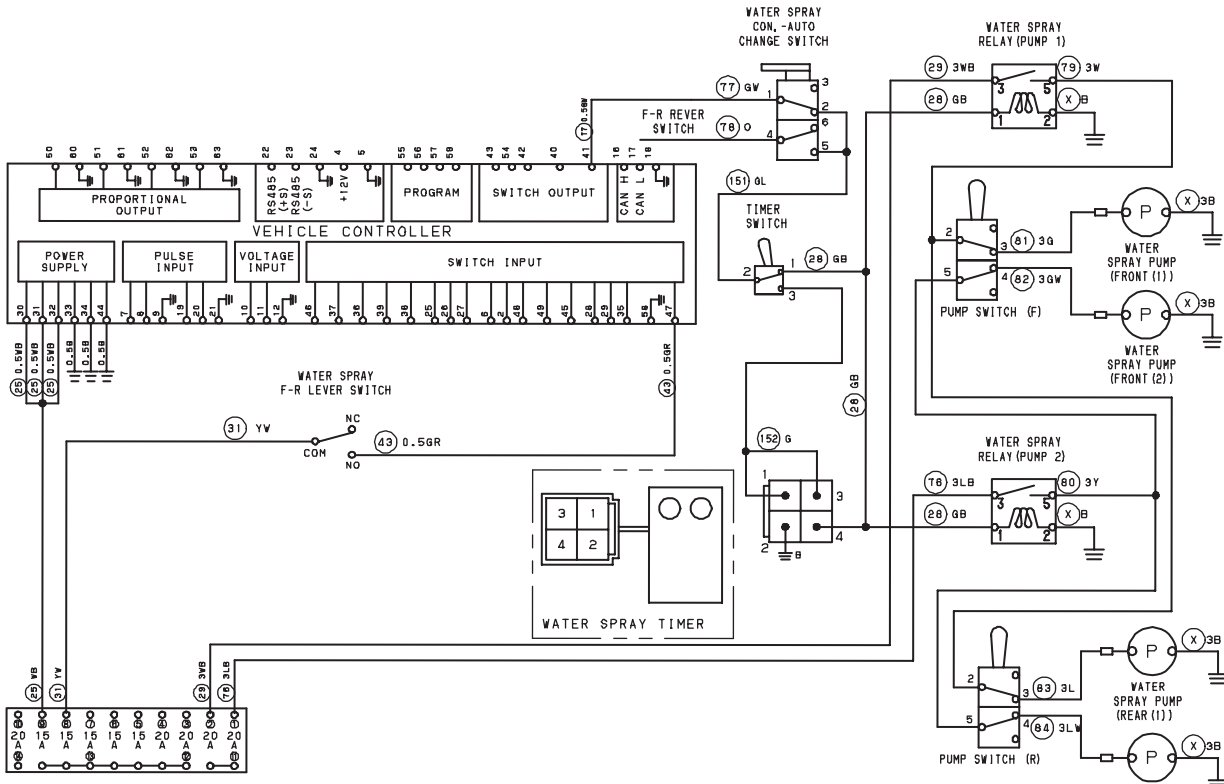

2-8. Water Spray

Check the following item before troubleshooting.

- No fuse has been blown.

2-8-1. Continuous water spray cannot be performed (1/4)

- Set the water spray mode (continuous/automatic) selector switch to the continuous position.
- Set the timer switch to the OFF position.
- Set the water spray pump switch to the simultaneous spray position.

Reference Fig. : 2-8-1

Check point	Check/Cause	Action
1. Battery Capacity	<ul style="list-style-type: none"> - Measure the battery voltage or specific gravity. Standard voltage: 12V or more Standard specific gravity: 1.26 or more - If the measured value is below the standard, the battery capacity is insufficient. 	Charge or replace the battery.
2. Water Spray Pump	<p>(1) When the starter switch is ON and the blue button on the water spray forward-reverse lever switch is pressed once, measure the voltage between each water spray pump's inlet G, GW, L and LW wires and the chassis ground. Standard voltage: 12V or more</p> <p>(2) Check if the grounding of each water spray pump is normal.</p> <ul style="list-style-type: none"> - If the above items (1) and (2) are OK and the water spray pump does not operate, the water spray pump is faulty. <p>(NOTICE)</p> <ul style="list-style-type: none"> • There are a total of four water spray pumps, two each for the front and rear drums. - Pressing the blue button on the water spray forward-reverse lever switch turns on the power and the power is turned off when the switch is pressed again. 	Replace the water spray pump.
3. Water Spray Forward-Reverse Lever Switch	<ul style="list-style-type: none"> - Measure the resistance between the water spray forward-reverse lever switch COM terminal YW wire and the NO terminal GR wire with the blue button on the water spray forward-reverse lever switch pressed. Standard resistance: 10 Ω or less - If the resistance is abnormal, the water spray forward-reverse lever switch is faulty. <p>(NOTICE)</p> <ul style="list-style-type: none"> • Pressing the blue button on the water spray forward-reverse lever switch turns on the power and the power is turned off when the switch is pressed again. 	Replace the water spray forward-reverse lever switch.
4. Water Spray (Continuous/Automatic) Selector Switch	<p>(1) When the starter switch is ON and the blue button on the water spray forward-reverse lever switch is pressed once, measure the voltage between the water spray mode (continuous/automatic) selector switch pin 1 inlet GW wire and the chassis ground. Standard voltage: 12V</p> <p>(2) When the starter switch is ON and the blue button on the water spray forward-reverse lever switch is pressed once, measure the voltage between the water spray mode (continuous/automatic) selector switch pin 2 inlet GL wire and the chassis ground. Standard voltage: 12V</p> <ul style="list-style-type: none"> - If the above item (1) is OK and the item (2) is NG, the water spray mode (continuous/automatic) selector switch is faulty. 	Replace the water spray mode (continuous/automatic) selector switch.

Fig. : 2-8-1

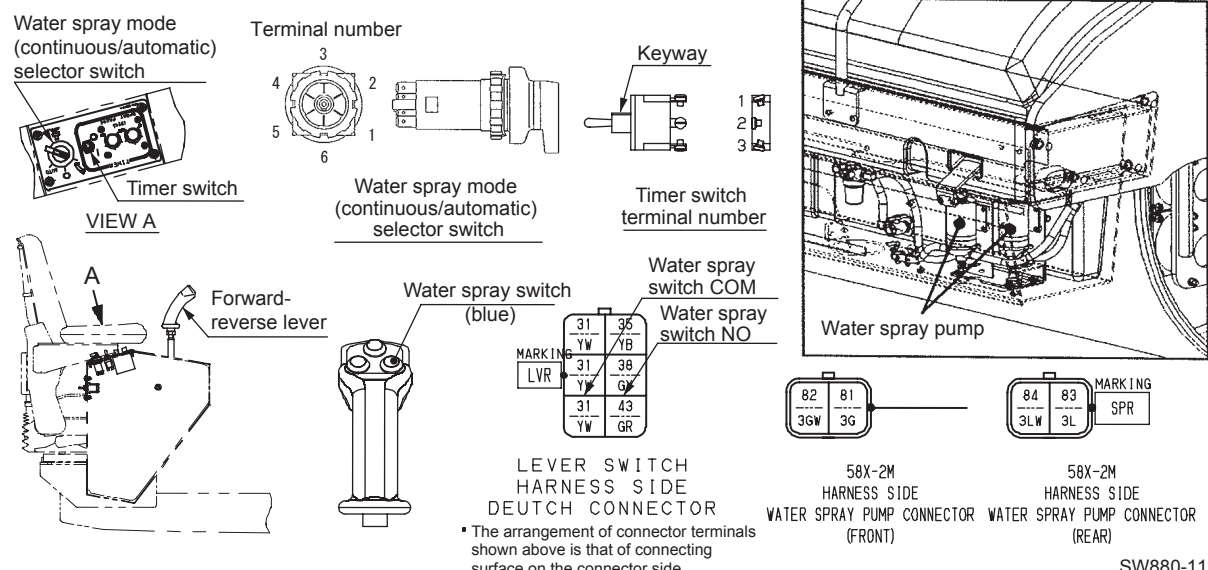
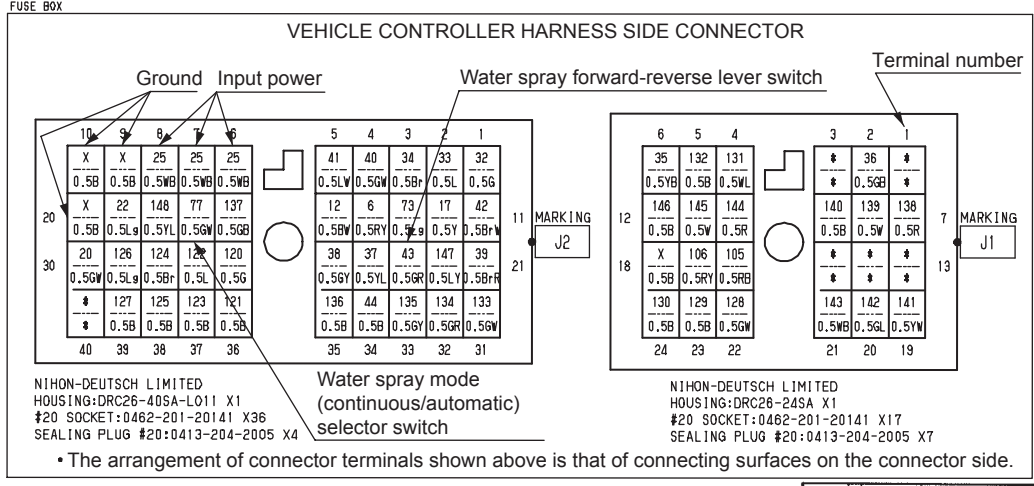
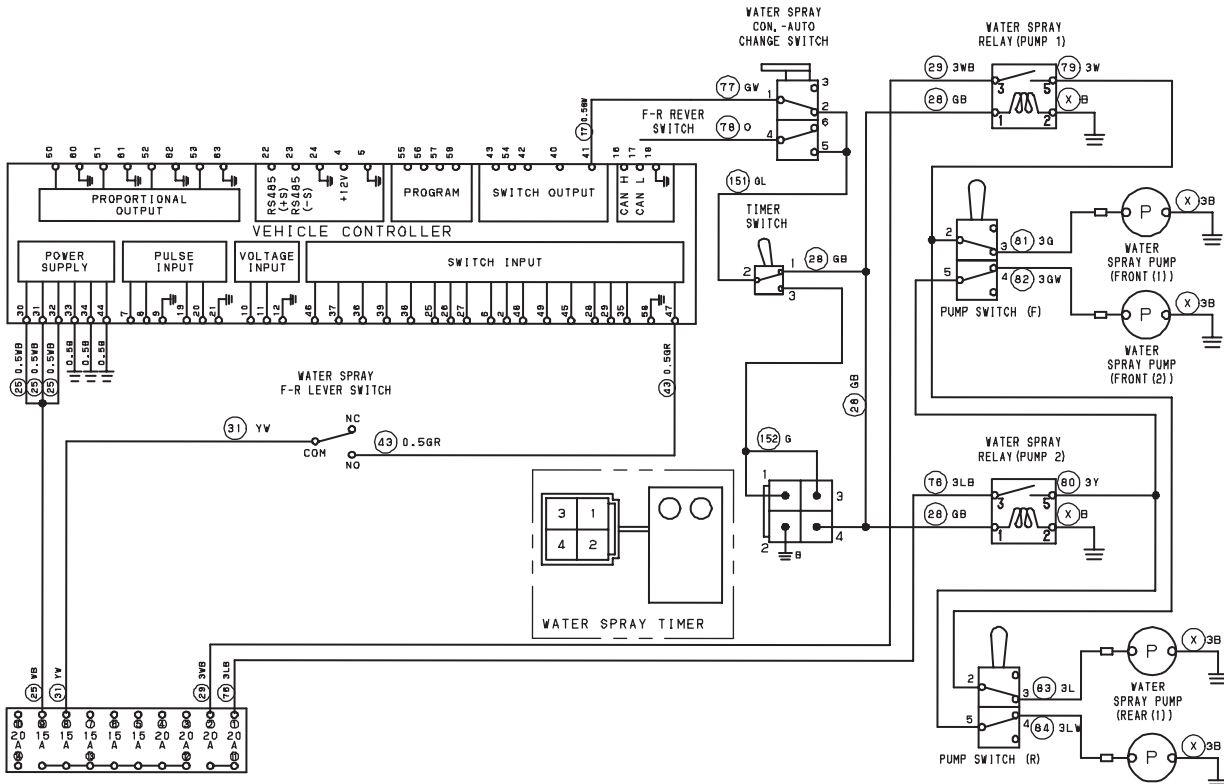

2-8-1. Continuous water spray cannot be performed (2/4)

- Set the water spray mode (continuous/automatic) selector switch to the continuous position.
- Set the timer switch to the OFF position.
- Set the water spray pump switch to the simultaneous spray position.

Reference Fig. : 2-8-1

Check point	Check/Cause	Action
5. Timer Switch	<p>(1) When the starter switch is ON and the blue button on the water spray forward-reverse lever switch is pressed once, measure the voltage between the timer switch pin 2 inlet GL wire and the chassis ground. Standard voltage: 12V</p> <p>(2) When the starter switch is ON and the blue button on the water spray forward-reverse lever switch is pressed once, measure the voltage between the timer switch pin 1 inlet GB wire and the chassis ground. Standard voltage: 12V</p> <p>- If the above item (1) is OK and the item (2) is NG, the timer switch is faulty.</p>	Replace the timer switch.

Fig. : 2-8-2

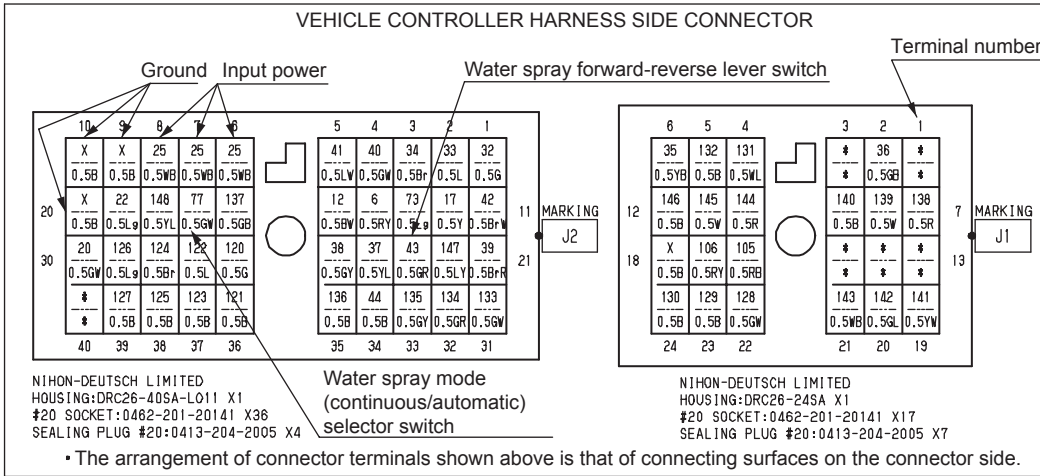
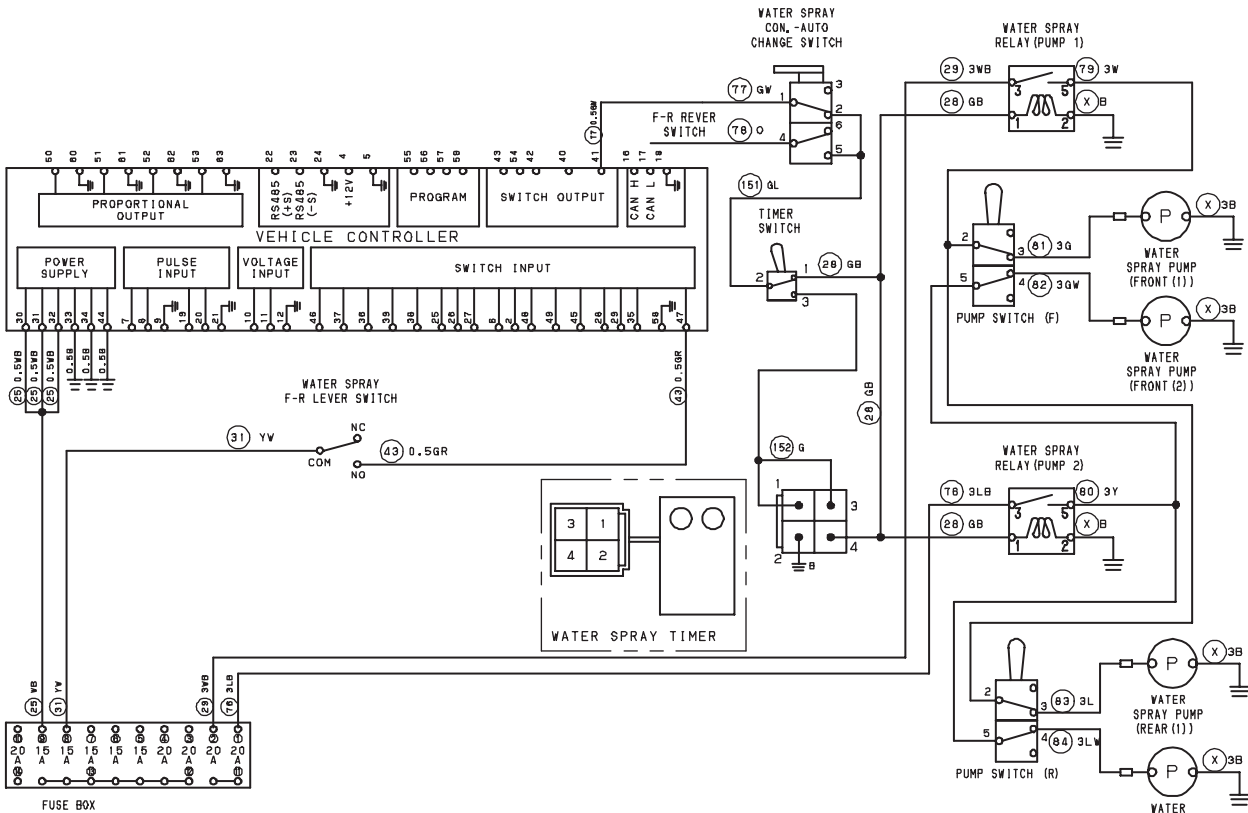

TERMINAL NUMBER

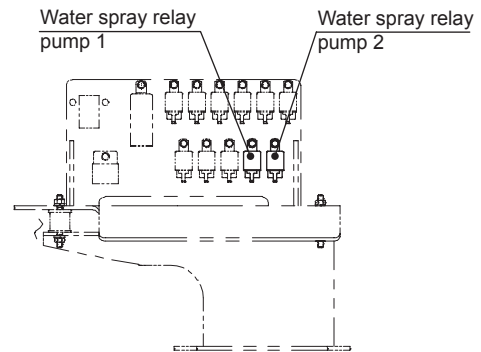
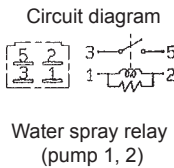
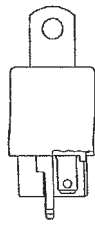
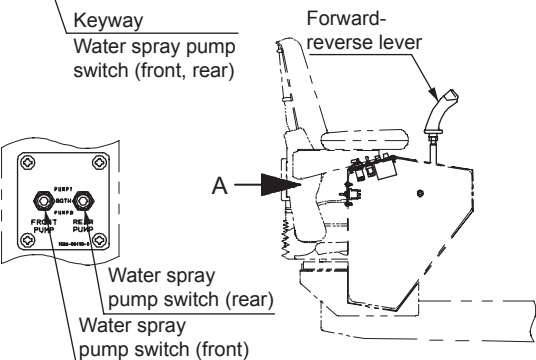
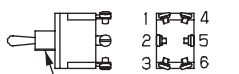

2-8-1. Continuous water spray cannot be performed (3/4)

- Set the water spray mode (continuous/automatic) selector switch to the continuous position.
- Set the timer switch to the OFF position.
- Set the water spray pump switch to the simultaneous spray position.

Reference Fig. : 2-8-2

Check point	Check/Cause	Action
6. Water Spray Relay (for Pump 1)	<p>(1) When the starter switch is ON and the blue button on the water spray forward-reverse lever switch is pressed once, measure the voltage between the water spray relay pin 1 inlet GB wire and the chassis ground. Standard voltage: 12V</p> <p>(2) When the starter switch is ON and the blue button on the water spray forward-reverse lever switch is pressed once, measure the voltage between the water spray relay pin 3 inlet WB wire and the chassis ground. Standard voltage: 12V</p> <p>(3) When the starter switch is ON and the blue button on the water spray forward-reverse lever switch is pressed once, measure the voltage between the water spray relay pin 2 inlet B wire and the chassis ground. Standard voltage: 12V</p> <p>- If the above items (1), (2) and (3) are OK and no current is found in the water spray relay pin 5 inlet W wire, the water spray relay (for pump 1) is faulty.</p>	Replace the water spray relay.
7. Water Spray Relay (for Pump 2)	<p>(1) When the starter switch is ON and the blue button on the water spray forward-reverse lever switch is pressed once, measure the voltage between the water spray relay pin 1 inlet GB wire and the chassis ground. Standard voltage: 12V</p> <p>(2) When the starter switch is ON and the blue button on the water spray forward-reverse lever switch is pressed once, measure the voltage between the water spray relay pin 3 inlet LB wire and the chassis ground. Standard voltage: 12V</p> <p>(3) When the starter switch is ON and the blue button on the water spray forward-reverse lever switch is pressed once, measure the voltage between the water spray relay pin 2 inlet B wire and the chassis ground. Standard voltage: 12V</p> <p>- If the above items (1), (2) and (3) are OK and no current is found in the water spray relay pin 5 inlet Y wire, the water spray relay (for pump 2) is faulty.</p>	Replace the water spray relay.
8. Water Spray Pump Switch (for Front Water Spray Pump)	<p>(1) When the starter switch is ON and the blue button on the water spray forward-reverse lever switch is pressed once, measure the voltage between the water spray pump switch pin 2 inlet W wire and pin 5 inlet Y wire and the chassis ground. Standard voltage: 12V</p> <p>(2) When the starter switch is ON and the blue button on the water spray forward-reverse lever switch is pressed once, measure the voltage between the water spray pump switch pin 3 inlet G wire and pin 4 inlet GW wire and the chassis ground. Standard voltage: 12V</p> <p>- If the above item (1) is OK and the item (2) is NG, the water spray pump switch (for the front water spray pump) is faulty.</p>	Replace the water spray pump switch.

Fig. : 2-8-2

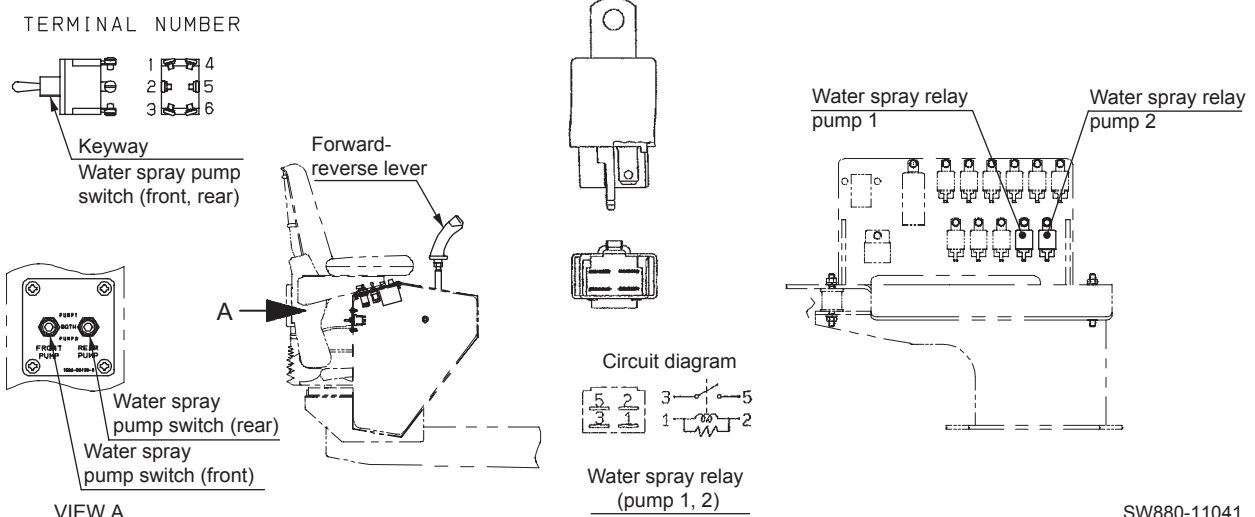
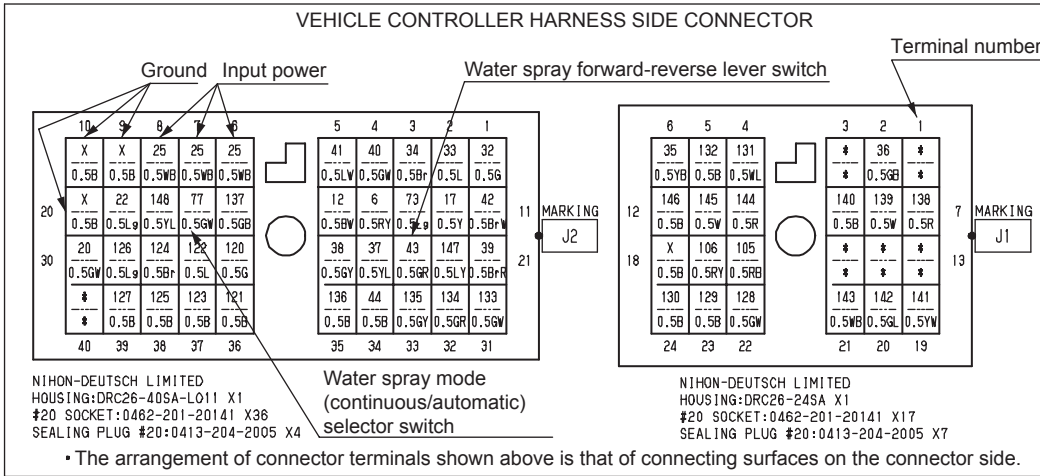
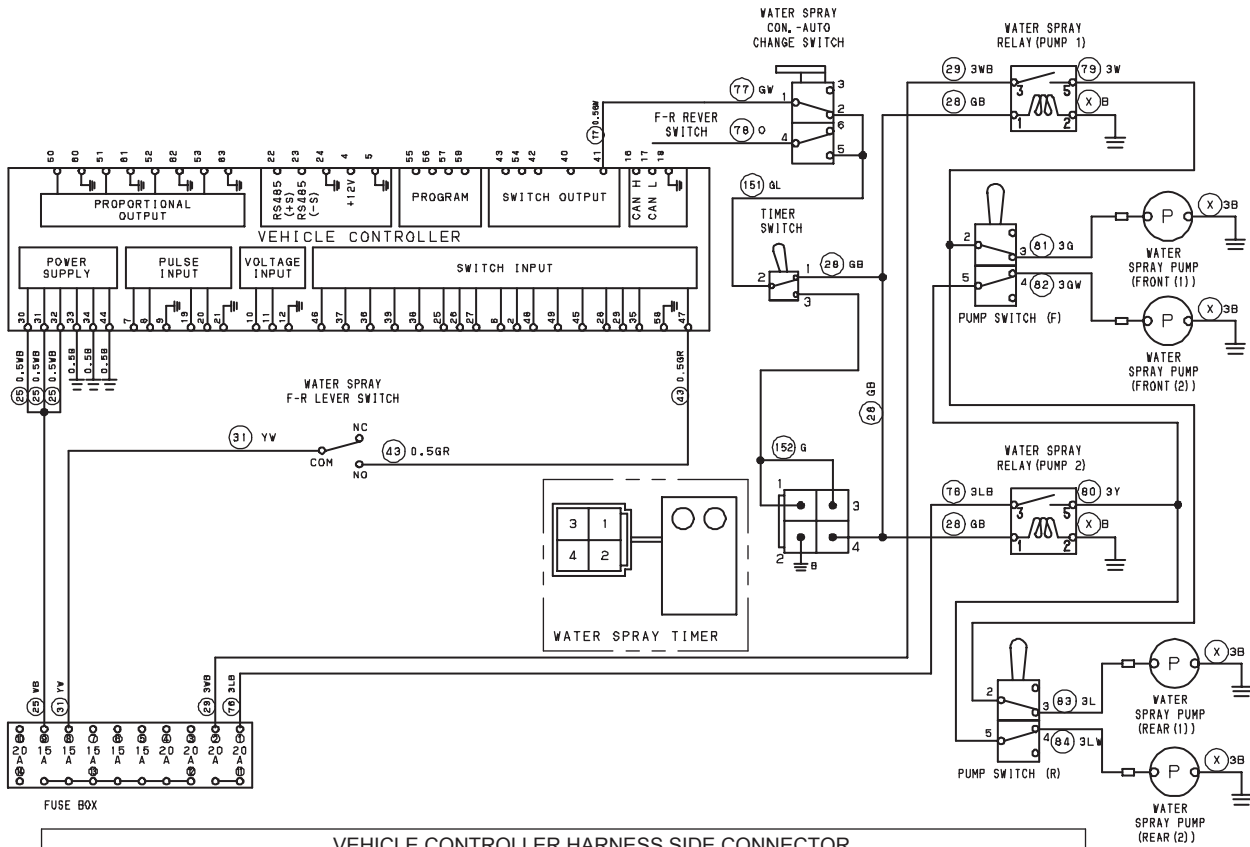

2-8-1. Continuous water spray cannot be performed (4/4)

- Set the water spray mode (continuous/automatic) selector switch to the continuous position.
- Set the timer switch to the OFF position.
- Set the water spray pump switch to the simultaneous spray position.

Reference Fig. : 2-8-2

Check point	Check/Cause	Action
9. Water Spray Pump Switch (for Rear Water Spray Pump)	<p>(1) When the starter switch is ON and the blue button on the water spray forward-reverse lever switch is pressed once, measure the voltage between the water spray pump switch pin 2 inlet W wire and pin 5 inlet Y wire and the chassis ground. Standard voltage: 12V</p> <p>(2) When the starter switch is ON and the blue button on the water spray forward-reverse lever switch is pressed once, measure the voltage between each of the water spray pump switch pin 3 inlet L wire and pin 4 inlet LW wire and the chassis ground. Standard voltage: 12V</p> <p>- If the above item (1) is OK and the item (2) is NG, the water spray pump switch (for the rear water spray pump) is faulty.</p>	Replace the water spray pump switch.
10. Vehicle Controller	<p>(1) When the starter switch is ON, measure the voltage between the vehicle controller input power supply pins 30, 31 and 32 and the ground terminals 33, 34 and 44. Standard voltage: 12V or more</p> <p>(2) When the starter switch is ON, measure the voltage between the vehicle controller pin 47 and the chassis ground with the blue button on the water spray forward-reverse lever switch pressed. Standard voltage: 12V</p> <p>(3) When the starter switch is ON and the blue button on the water spray forward-reverse lever switch is pressed once, measure the voltage between the vehicle controller pin 41 and the chassis ground. Standard voltage: 12V</p> <p>- If the above items (1) and (2) are OK and the item (3) is NG, the vehicle controller is faulty.</p>	Replace the vehicle controller.
11. Harness Connecting Between Terminals	<p>- Measure the resistance of the harness connecting between terminals. Standard resistance: 10 Ω or less</p> <p>- If the resistance is abnormal, the harness is faulty.</p>	Repair or replace the harness.

Fig. : 2-8-3

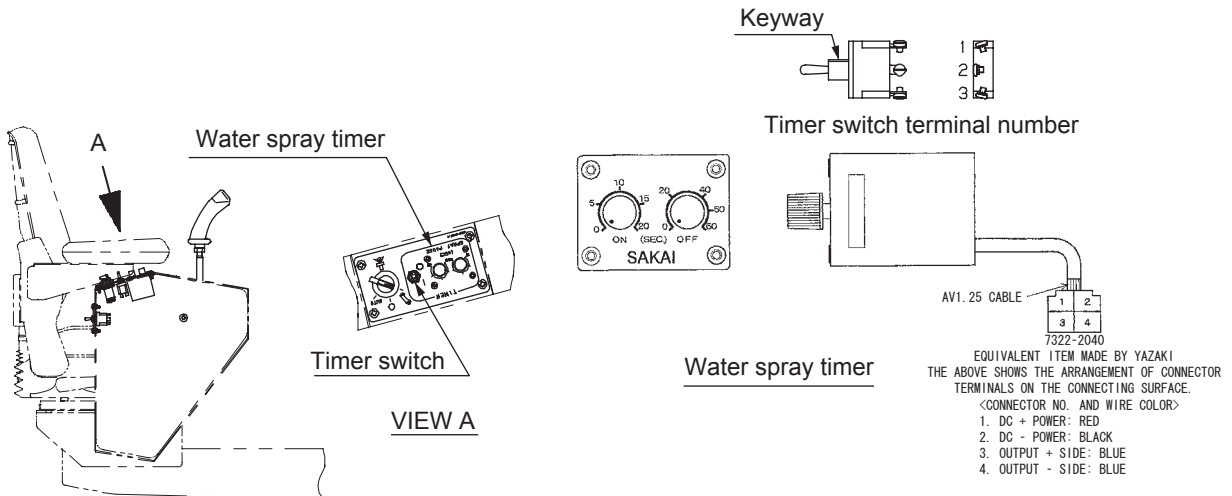
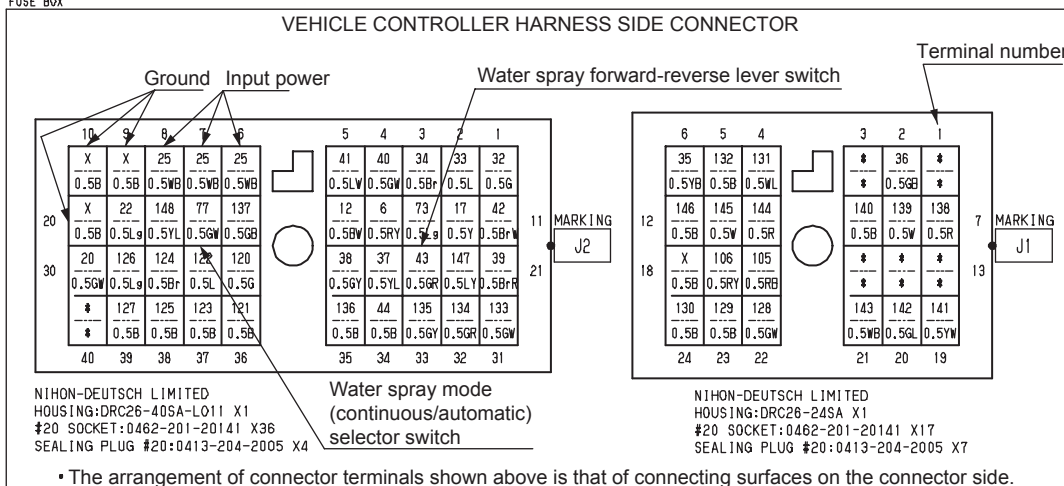
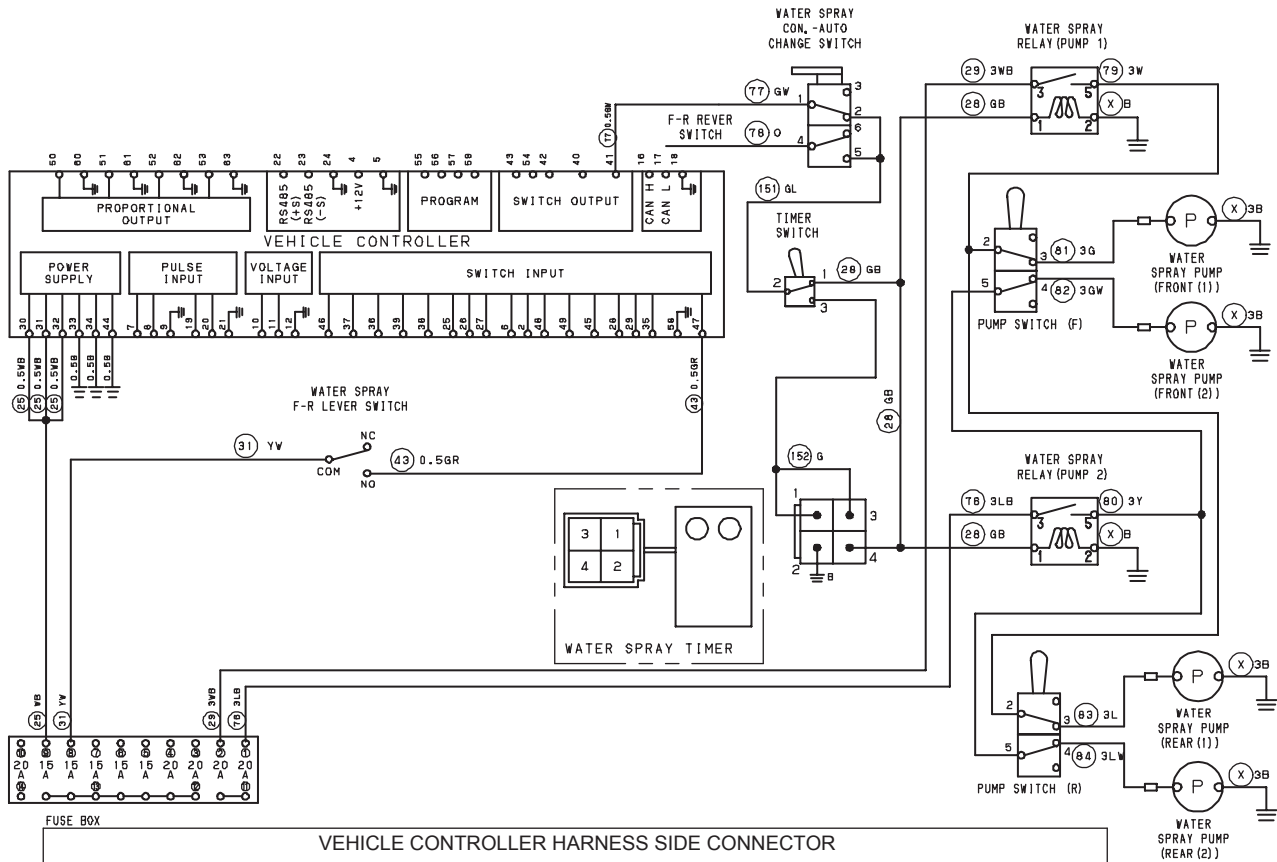

2-8-2. Continuous water spray works, but intermittent water spray cannot be performed

- Set the water spray mode (continuous/automatic) selector switch to the continuous position.
- Set the timer switch to the ON position.
- Set the water spray pump switch to the simultaneous spray position.

Reference Fig. : 2-8-3

Check point	Check/Cause	Action
1. Water Spray Timer	<p>(1) When the starter switch is ON and the blue button on the water spray forward-reverse lever switch is pressed once, measure the voltage between the water spray timer pins 1 and 3 inlet G wires and the chassis ground. Standard voltage: 12V</p> <p>(2) When the starter switch is ON and the blue button on the water spray forward-reverse lever switch is pressed once, measure the voltage between the water spray timer pin 4 inlet GB wire and the chassis ground. Standard voltage: 12V</p> <p>- If the above item (1) is OK and the item (2) is NG with no abnormality found in the grounding of the water spray timer unit, the water spray timer is faulty.</p>	Replace the water spray timer.
2. Timer Switch	<p>(1) When the starter switch is ON and the blue button on the water spray forward-reverse lever switch is pressed once, measure the voltage between the timer switch pin 2 inlet GL wire and the chassis ground. Standard voltage: 12V</p> <p>(2) When the starter switch is ON and the blue button on the water spray forward-reverse lever switch is pressed once, measure the voltage between the timer switch pin 3 inlet G wire and the chassis ground. Standard voltage: 12V</p> <p>- If the above item (1) is OK and the item (2) is NG, the timer switch is faulty.</p>	Replace the timer switch.
3. Harness Connecting Between Terminals	<p>- Measure the resistance of the harness connecting between terminals. Standard resistance: 10 Ω or less</p> <p>- If the resistance is abnormal, the harness is faulty.</p>	Repair or replace the harness.

Fig. : 2-8-4

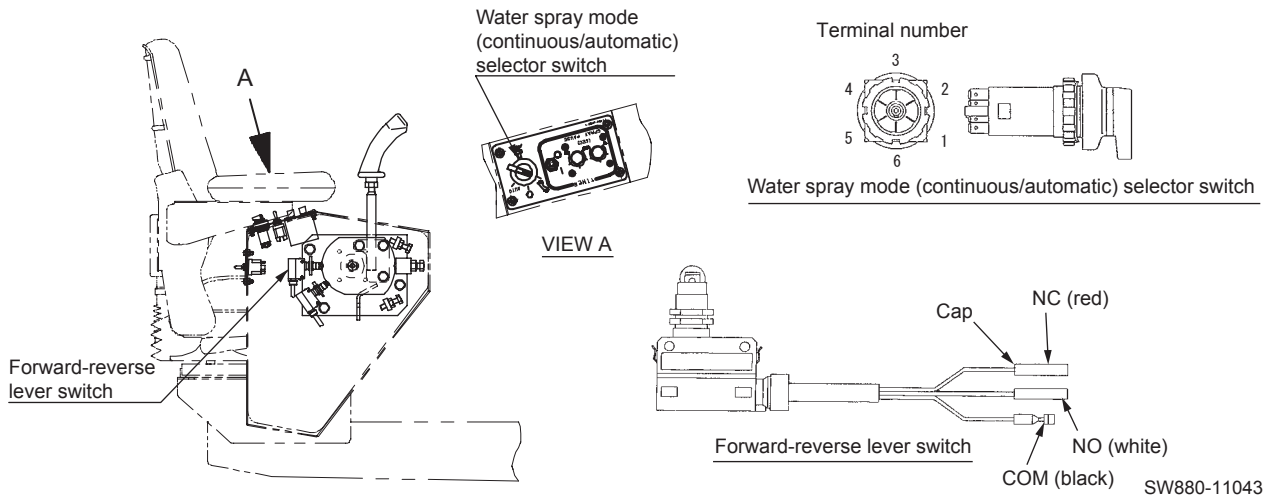
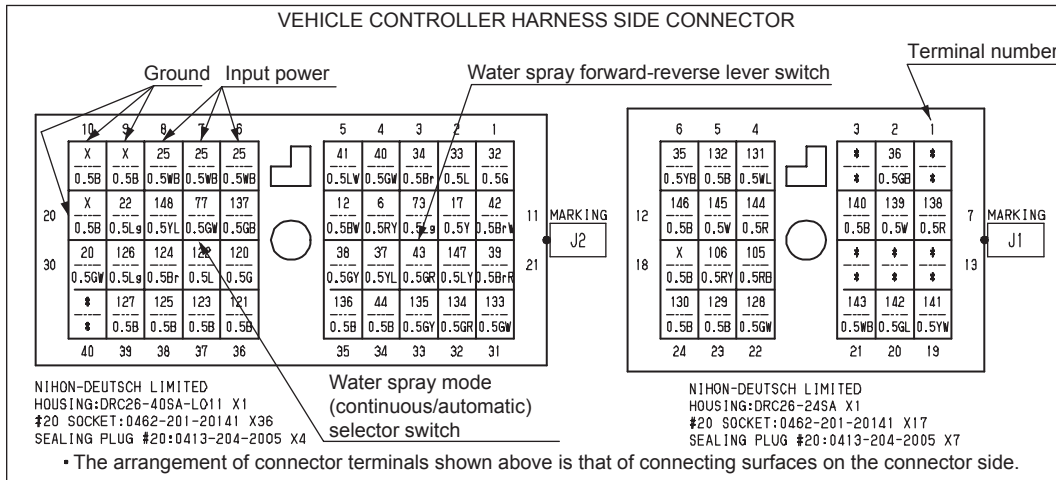
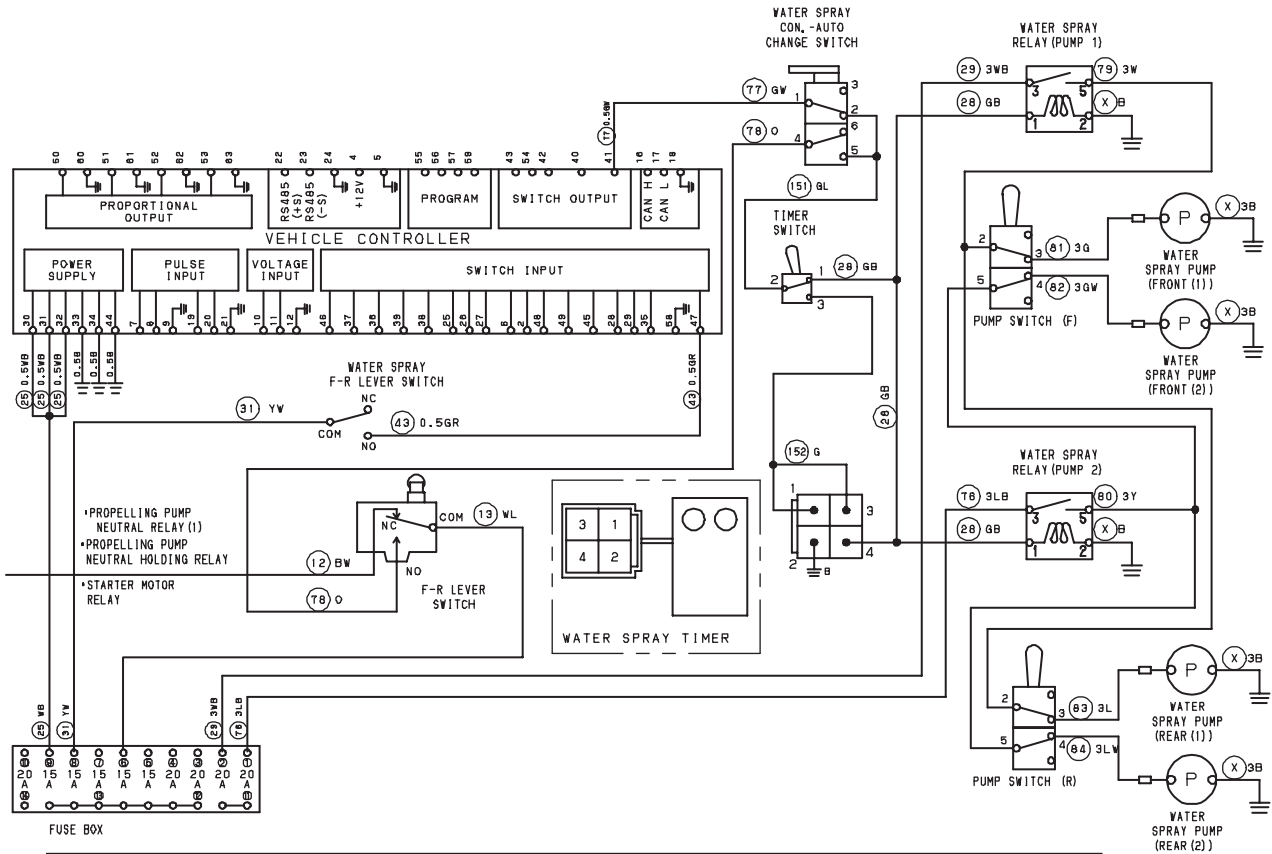

2-8-3. Continuous water spray works, but automatic water spray cannot be performed

- Set the water spray mode (continuous/automatic) selector switch to the automatic position.
- Set the timer switch to the OFF position.
- Set the water spray pump switch to the simultaneous spray position.

Reference Fig. : 2-8-4

Check point	Check/Cause	Action
1. Forward-Reverse Lever Switch	<p>(1) When the forward-reverse lever switch is in the neutral position and the starter switch is OFF, check the continuity between the forward-reverse lever switch COM terminal inlet and the NC terminal. There is continuity in the normal condition.</p> <p>(2) When the forward-reverse lever switch is in the forward or reverse position and the starter switch is OFF, check the continuity between the forward-reverse lever switch COM terminal inlet and the NO terminal. There is continuity in the normal condition.</p> <p>- If the above item (1) or (2) is NG, the forward-reverse lever switch is faulty.</p>	Replace the forward-reverse lever switch.
2. Water Spray Mode (Continuous/Automatic) Selector Switch	<p>(1) When the forward-reverse lever switch is in the forward or reverse position and the starter switch is ON, measure the voltage between the water spray mode (continuous/automatic) selector switch pin 4 inlet O wire and the chassis ground. Standard voltage: 12V</p> <p>(2) When the forward-reverse lever switch is in the forward or reverse position and the starter switch is ON, measure the voltage between the water spray mode (continuous/automatic) selector switch pin 5 GL wire and the chassis ground. Standard voltage: 12V</p> <p>- If the above item (1) is OK and the item (2) is NG, the water spray mode (continuous/automatic) selector switch is faulty.</p>	Replace the water spray mode (continuous/automatic) selector switch.
3. Harness Connecting Between Terminals	<p>- Measure the resistance of the harness connecting between terminals. Standard resistance: 10 Ω or less</p> <p>- If the resistance is abnormal, the harness is faulty.</p>	Repair or replace the harness.

Fig. : 2-9-1

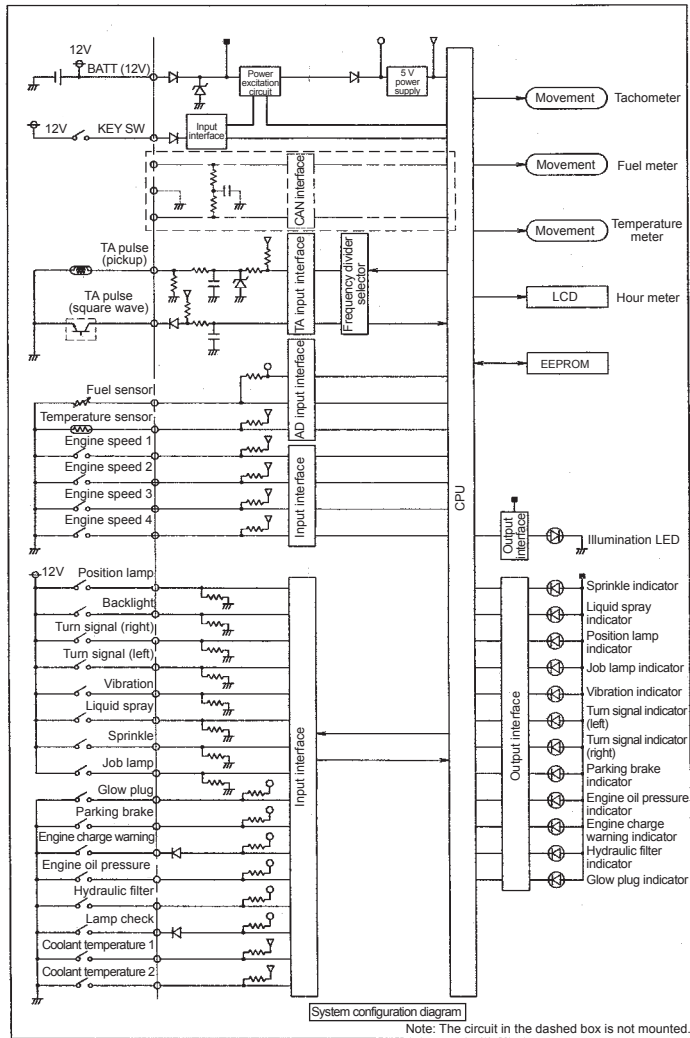
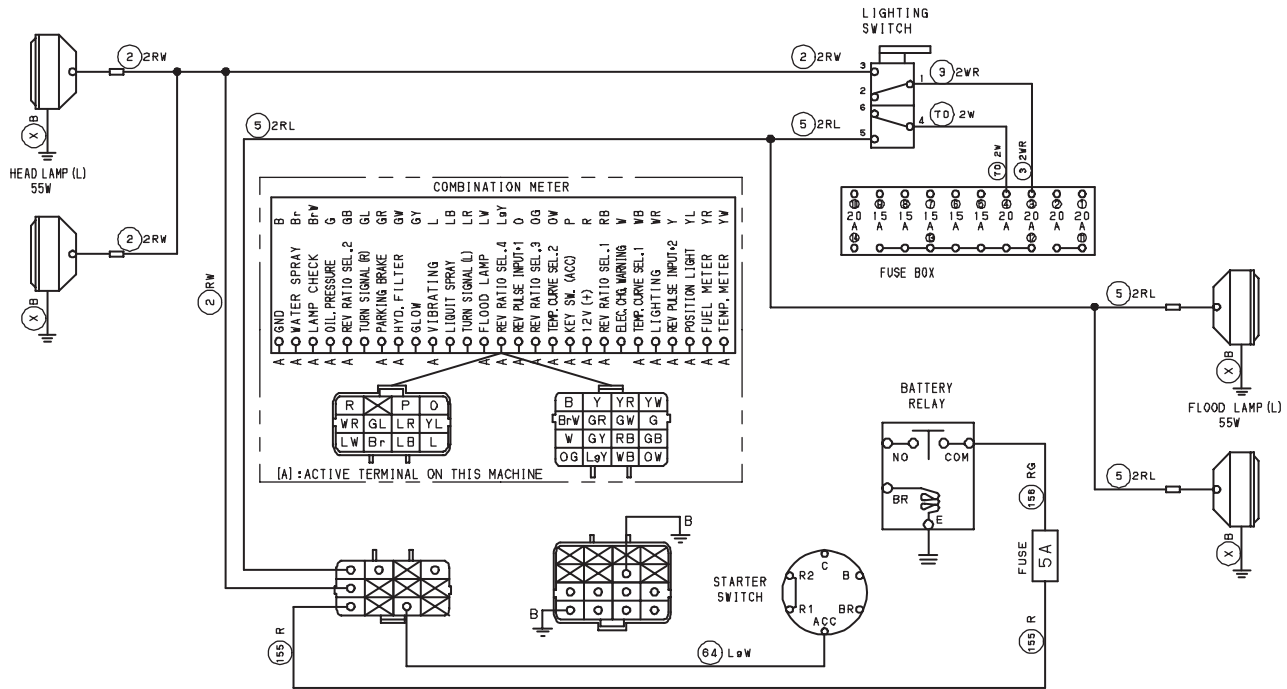

Combination meter circuit diagram

Combination meter

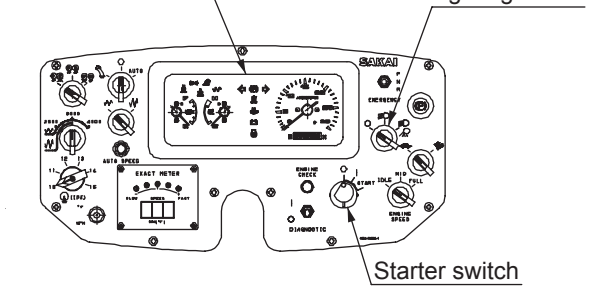

Terminal	B	R1	R2	ACC	BR	C
HEAT						
OFF						
ON						
START						

Starter switch connection table

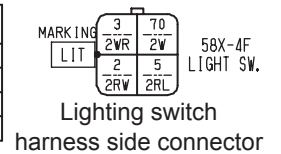

Lighting switch harness side connector

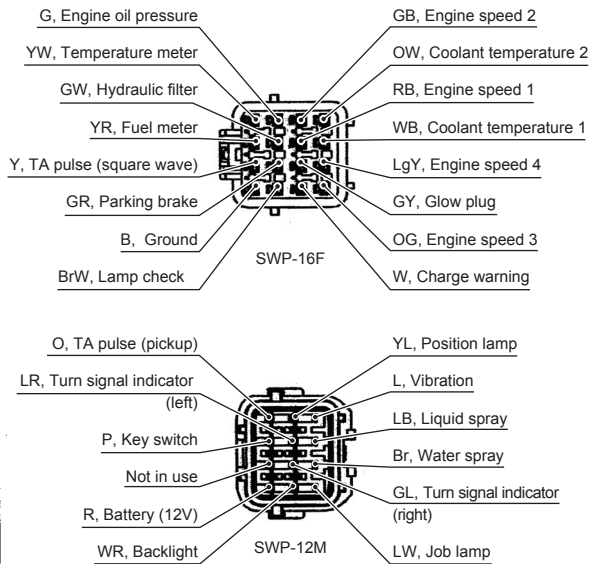

Combination meter connector SW880-11044

2-9. Lighting

Check the following item before troubleshooting.

- No fuse has been blown.

2-9-1. Headlamps and working lamps do not light

Reference Fig. : 2-9-1

Check point	Check/Cause	Action
1. Battery Capacity	<ul style="list-style-type: none"> - Measure the battery voltage or specific gravity Standard voltage: 12V or more Standard specific gravity: 1.26 or more - If the measured value is below the standard, the battery capacity is insufficient. 	Charge or replace the battery.
2. Each Bulb	<ul style="list-style-type: none"> - Check that none of the lamp bulbs of the headlamps and working lamps is burned out or has a contact failure. - The bulb is faulty or poorly connected. 	Replace each bulb.
3. Lighting Switch	<p>(1) When the starter switch is ON, measure the voltage between the lighting switch pin 1 inlet WR wire and pin 4 inlet W wire and the chassis ground. Standard voltage: 12V or more</p> <p>(2) When the starter switch is turned ON and the first stage of the lighting switch is also turned ON, measure the voltage between the lighting switch pin 3 inlet RW wire and the chassis ground. Standard voltage: 12V or more</p> <p>(3) When the starter switch is turned ON and the second stage of the lighting switch is also turned ON, measure the voltage between the lighting switch pin 5 inlet RL wire and the chassis ground. Standard voltage: 12V or more</p> <ul style="list-style-type: none"> - If the above item (1) is OK and the item (2) or (3) is NG, the lighting switch is faulty. 	Replace the lighting switch.
4. Harness Connecting Between Terminals	<ul style="list-style-type: none"> - Measure the resistance of the harness connecting between terminals. Standard resistance: 10 Ω or less - If the resistance is abnormal, the harness is faulty. 	Repair or replace the harness.

Fig. : 2-9-1

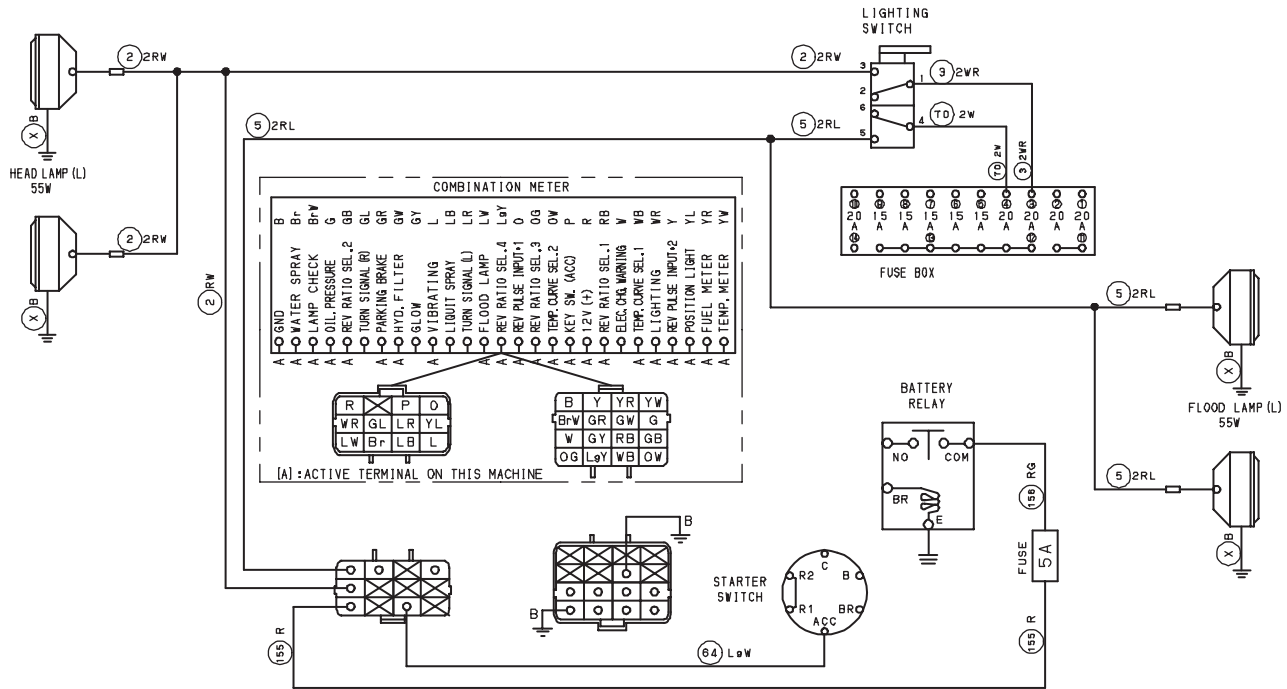

Combination meter Lighting switch

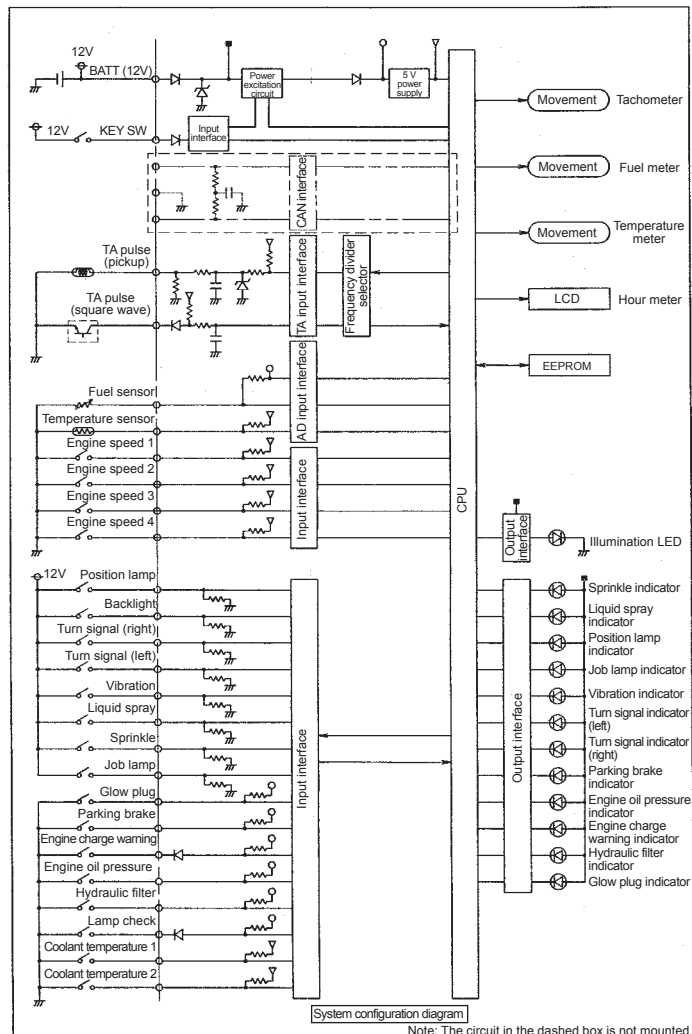

Combination meter circuit diagram

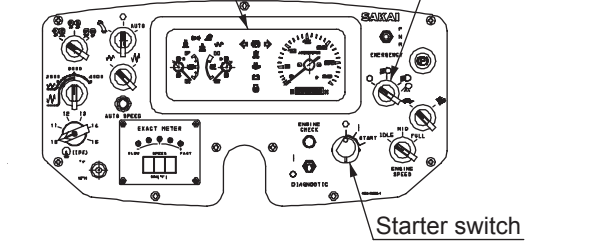

Terminal	B	R1	R2	ACC	BR	C
HEAT	○	○	○	○	○	○
OFF	○	○	○	○	○	○
ON	○	○	○	○	○	○
START	○	○	○	○	○	○

Starter switch connection table

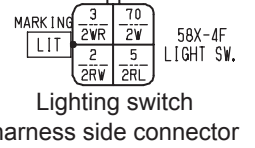

Lighting switch harness side connector

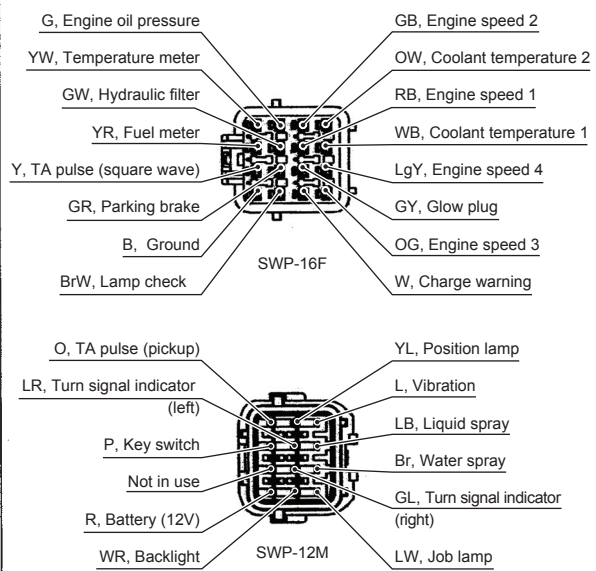

Combination meter connector SW880-11044

2-9-2. Illumination of combination meter does not turn on

- Check that the headlamps turn on.

Reference Fig. : 2-9-1

Check point	Check/Cause	Action
1. Harness	- Measure the resistance between the lighting switch pin 3 inlet RW wire and the combination meter connector pin RW wire 2. Standard resistance: 10 Ω or less - If the resistance is abnormal, the harness is faulty.	Repair or replace the harness.
2. Combination Meter	(1) When the starter switch is ON, measure the voltage between the combination meter terminal R wire (battery terminal) and P wire (starter switch terminal) and the ground terminal B wire. Standard voltage: 12V or more (2) When the starter switch is turned ON and the first stage of the lighting switch is also turned ON, measure the voltage between the combination meter terminal WR wire (back light terminal) and the chassis ground. Standard voltage: 12V or more - If the above items (1) and (2) are OK, the combination meter is faulty.	Replace the combination meter.

2-9-3. Combination meter warning lamp or indicator lamp is abnormal**Reference Fig. : 2-9-1**

Check point	Check/Cause	Action
1. Combination Meter	(1) When the starter switch is ON, measure the voltage between the combination meter terminal R wire (battery terminal) and P wire (starter switch terminal) and the ground terminal B wire. Standard voltage: 12V or more (2) When the starter switch is turned to START, check that the parking brake indicator lamp, hydraulic oil filter warning lamp, oil pressure warning lamp and charge warning lamp of the combination meter illuminate for three seconds and then go out. - If the above item (1) is OK and the item (2) is NG, the combination meter is faulty. (NOTICE) • Since the engine cannot start unless the parking brake switch is ON, the parking brake indicator lamp does not go out even after three seconds.	Replace the combination meter.

Fig. : 2-9-2

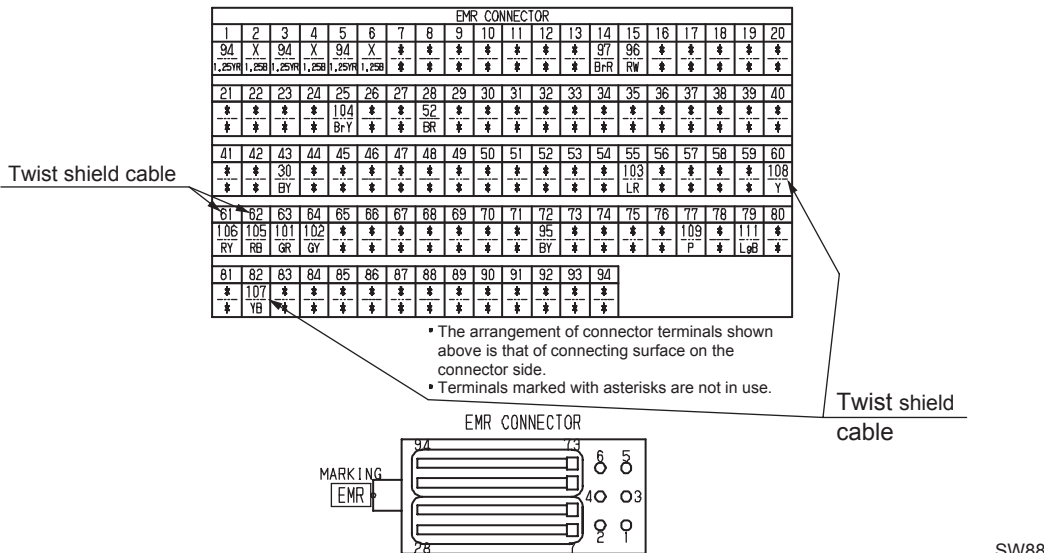
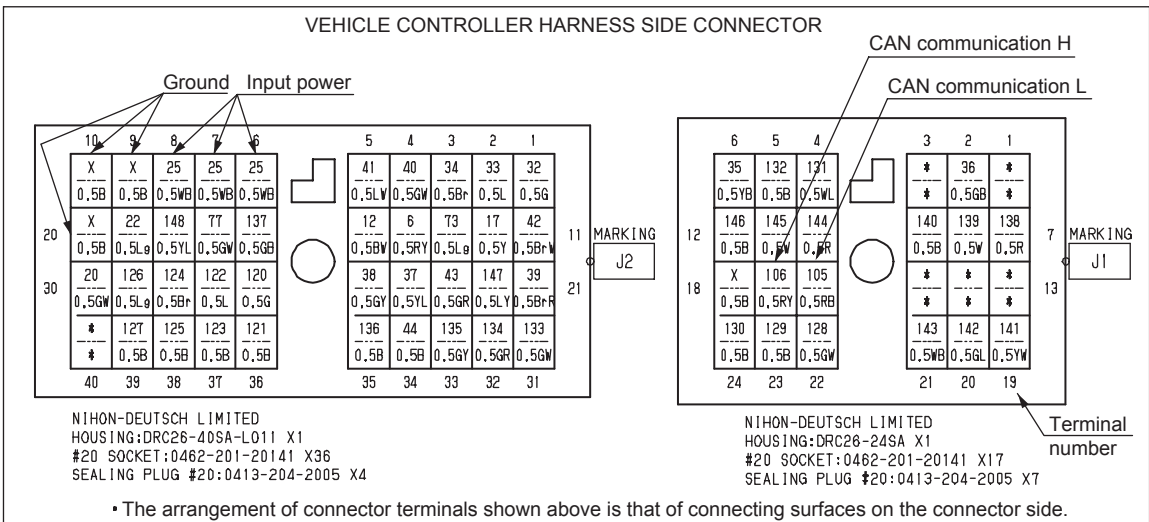
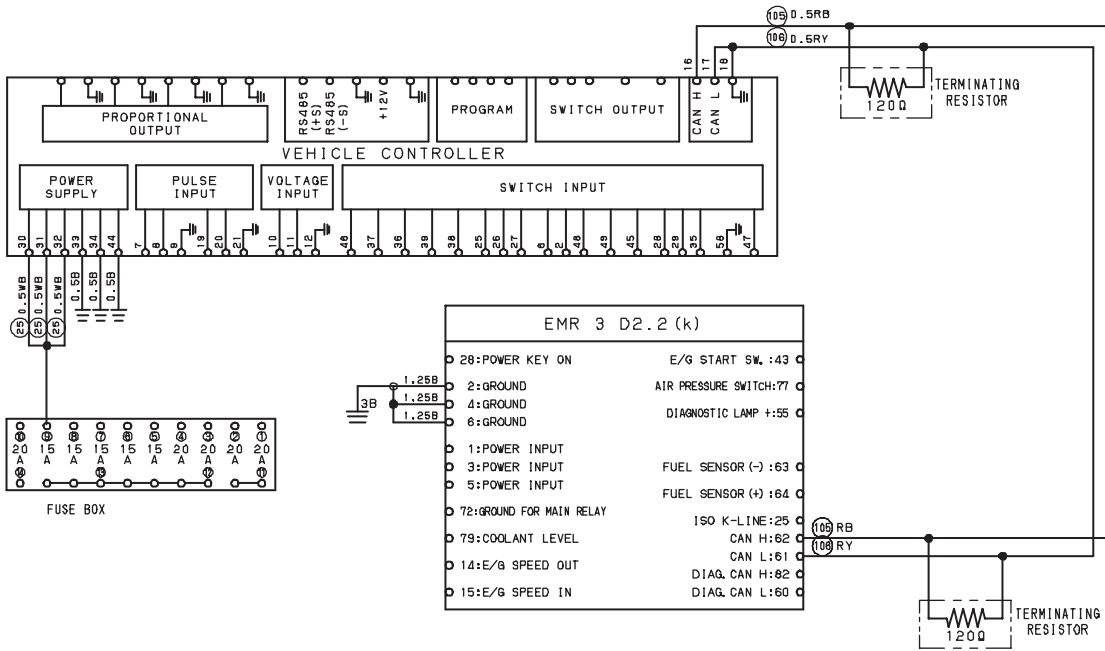

2-9-4. Tachometer reading is abnormal (1/2)

- Check if the engine check lamp is ON or blinking rapidly.

If so, identify the problem using the “Blink code list” shown in page 11-011.

Reference Fig. : 2-9-2

1) When the display shows any error code

Error code	Check point	Check/Cause	Action
E 41	1. Connector	- Check the EMR 3 connector (pins 61 and 62) and vehicle controller connector (pins 16 and 17) for corrosion, breakage, bending and looseness. - If any abnormality is found, the connector is faulty.	Replace the connector or terminal.
	2. Harness	- Measure the resistance between the EMR 3 connector pin 61 RY wire and pin 62 RB wire and the vehicle controller connector pin 17 RY wire and pin 16 RB wire. Standard resistance: 10 Ω or less - If the resistance is abnormal, the harness is faulty. (NOTICE) • Since shielded twisted wires are used for the CAN communication between the vehicle controller and the EMR 3, repair is not approved. Be sure to replace them.	Replace the harness.
	3. CAN Communication	- Faulty CAN communication (NOTICE) • Check if any CAN-related blink code for the engine is issued. If no blink code is issued, the vehicle controller is faulty.	Replace the vehicle controller.

Fig. : 2-9-3

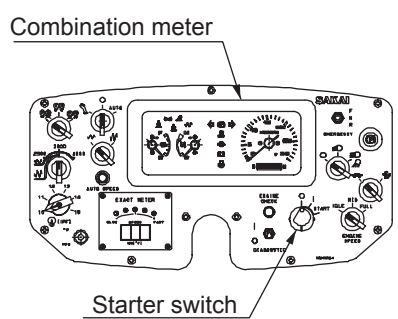
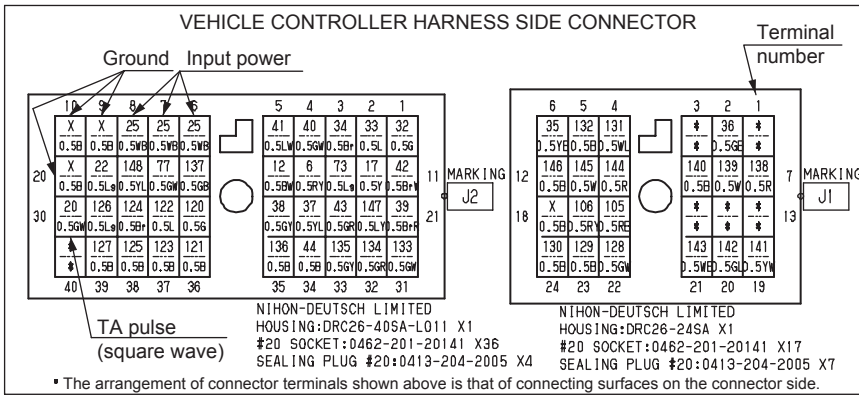
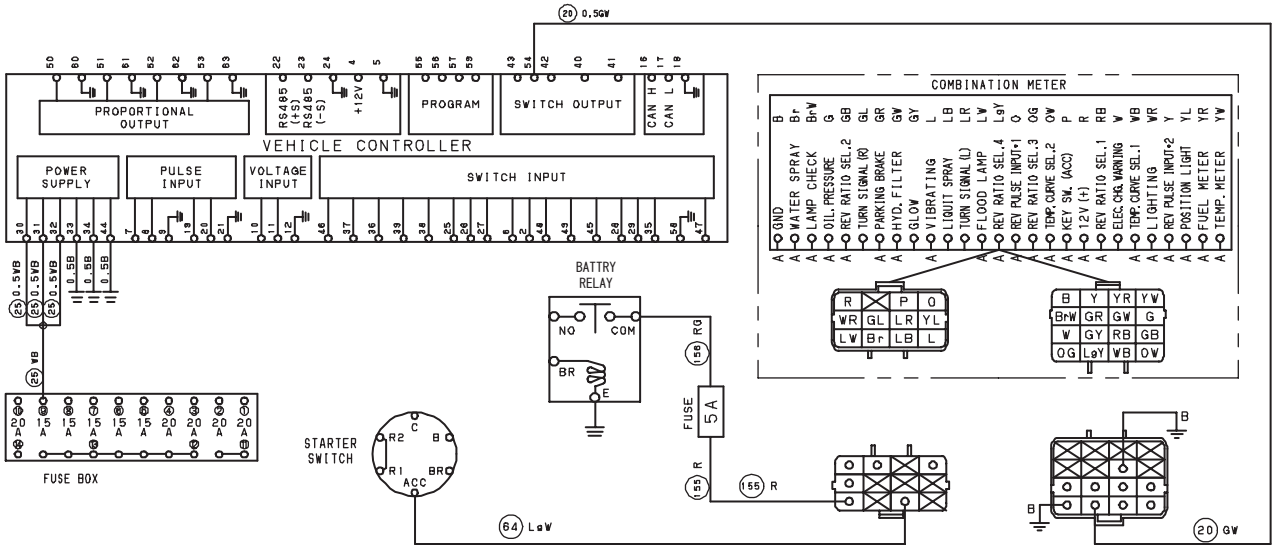

Terminal Key position	B	R1	R2	ACC	BR	C
HEAT	○	○	○	○	○	○
OFF	○	○	○	○	○	○
ON	○	○	○	○	○	○
START	○	○	○	○	○	○

Starter switch connection table

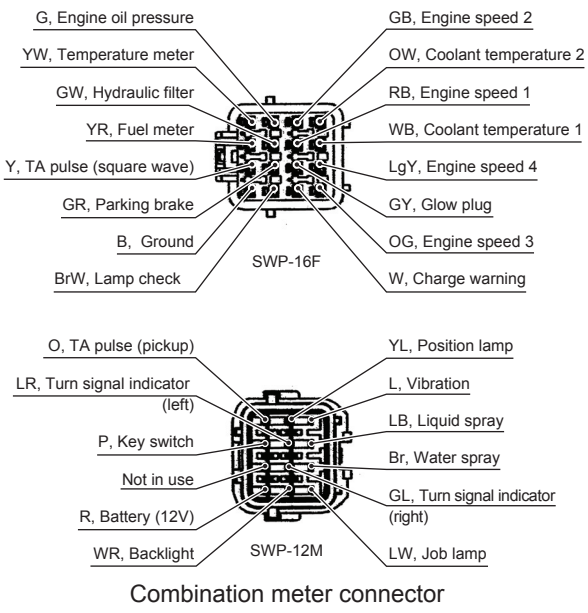
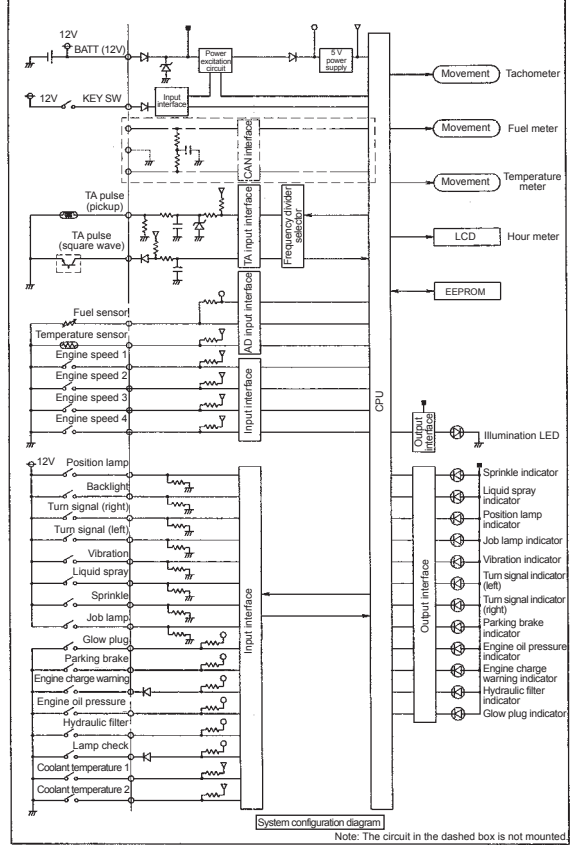

Combination meter circuit diagram

2-9-4. Tachometer reading is abnormal (2/2)

- Check if the engine check lamp is ON or blinking rapidly.
If so, identify the problem using the “Blink code list” shown in page 11-011.

Reference Fig. : 2-9-3

2) When the display shows no error code

Check point	Check/Cause	Action
1. Harness	- Measure the resistance between the vehicle controller connector pin 54 and the combination meter connector pin GW wire 20. Standard resistance: 10 Ω or less - If the resistance is abnormal, the harness is faulty.	Repair or replace the harness.
2. Combination Meter	(1) When the starter switch is ON, measure the voltage between the combination meter terminal R wire (battery terminal) and P wire (starter switch terminal) and the ground terminal B wire. Standard voltage: 12V or more (2) Check that the combination meter terminal RB wire (engine rotation 1) is grounded. (3) Start the engine and measure the pulse between the combination meter terminal Y wire (TA pulse terminal) and the chassis ground. Standard pulse: 2 pulses/rotation of the engine - If the above items (1) and (2) are OK and the item (3) is NG, the combination meter is faulty.	Replace the combination meter.
3. Vehicle Controller	- If the display shows no error code and the pulse is abnormal, the vehicle controller is faulty.	Replace the vehicle controller.

2-9-5. Hour meter is abnormal**Reference Fig. : 2-9-3**

Check point	Check/Cause	Action
1. Combination Meter	- When the starter switch is ON, measure the voltage between the combination meter terminal R wire (battery terminal) and P wire (starter switch terminal) and the ground terminal B wire. Standard voltage: 12V or more - If no abnormality is found, the combination meter is faulty.	Replace the combination meter.

Fig. : 2-9-4

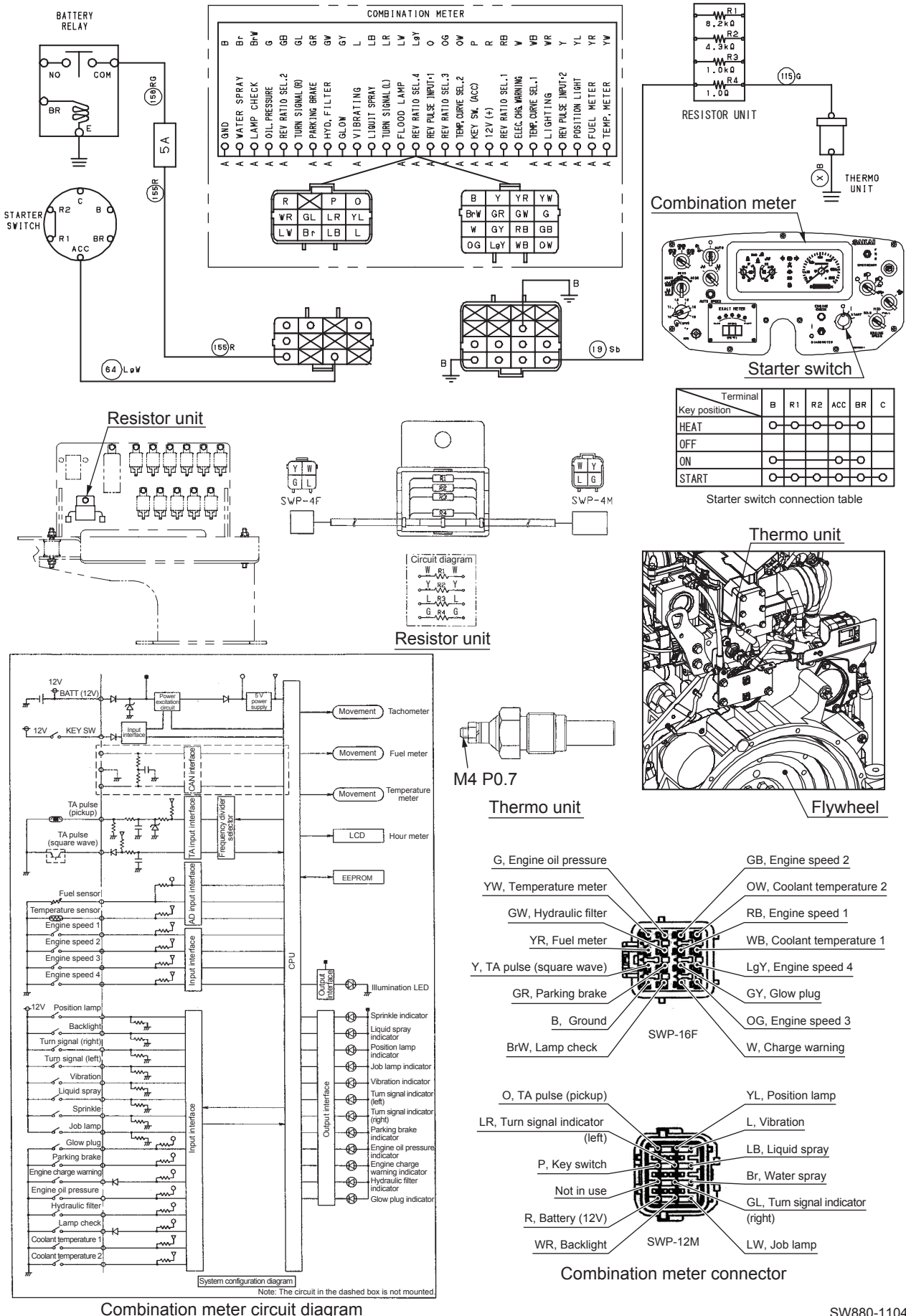

2-9-6. Temperature gauge is abnormal

Reference Fig. : 2-9-4

Check point	Check/Cause	Action
1. Thermo Unit	<ul style="list-style-type: none"> - Disconnect the harness and measure the resistance of the thermo unit. Standard resistance: 153.9 Ω [(at unit temperature of 50°C (122°F)) 27.4 Ω [(at unit temperature of 100°C (212°F)) - If the resistance is abnormal, the thermo unit is faulty. 	Replace the thermo unit.
2. Resistor Unit	<ul style="list-style-type: none"> - Measure the resistance between the resistor unit terminal inlet G wire and the outlet terminal Sb wire. Standard resistance: 1 Ω - If the resistance is abnormal, the resistor unit is faulty. <p>(NOTICE)</p> <ul style="list-style-type: none"> • Check that the resistance of the resistor unit R4 is normal. 	Replace the resistor unit.
3. Combination Meter	<ul style="list-style-type: none"> - When the starter switch is ON, measure the voltage between the combination meter terminal R wire (battery terminal) and P wire (starter switch terminal) and the ground terminal B wire. Standard voltage: 12V or more - If the above item is OK and no abnormality is found in the thermo unit and resistor unit, the combination meter is faulty. 	Replace the combination meter.
4. Harness Connecting Between Terminals	<ul style="list-style-type: none"> - Measure the resistance of the harness connecting between terminals. Standard resistance: 10 Ω or less - If the resistance is abnormal, the harness is faulty. 	Repair or replace the harness.

Fig. : 2-9-5

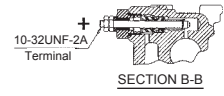
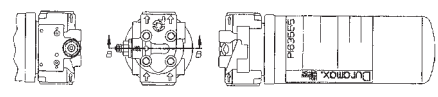
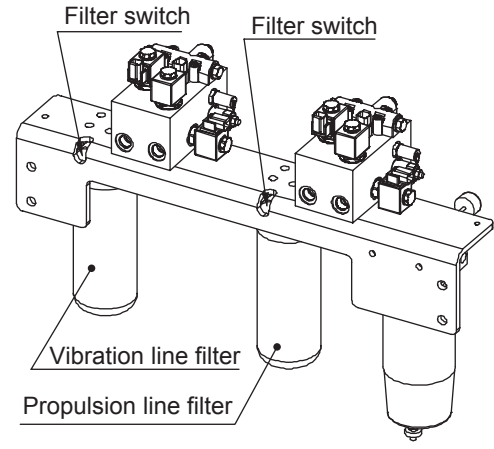
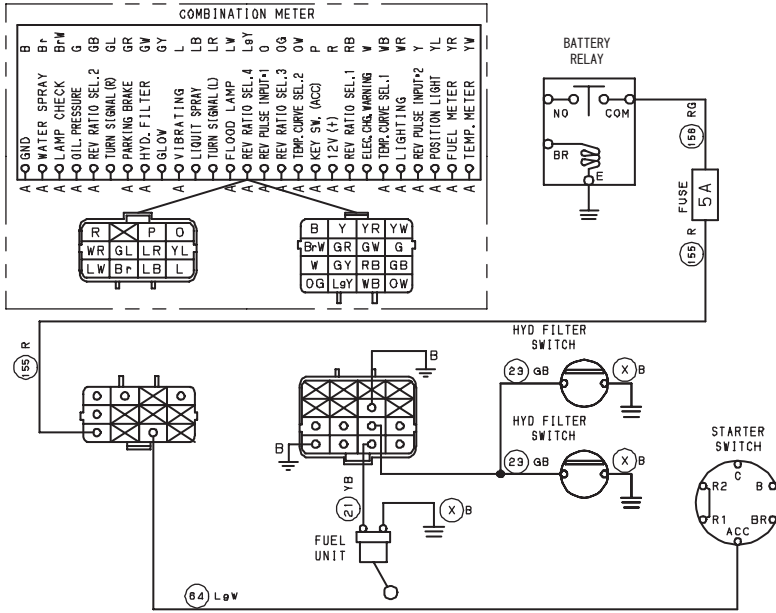

Line filter

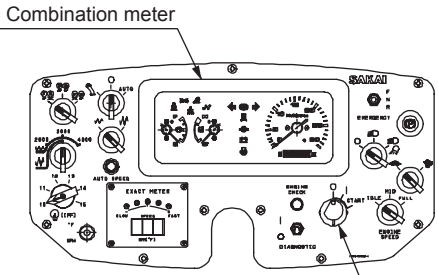

Terminal	B	R1	R2	ACC	BR	C
HEAT	○	○	○	○	○	○
OFF	○	○	○	○	○	○
ON	○	○	○	○	○	○
START	○	○	○	○	○	○

Starter switch connection table

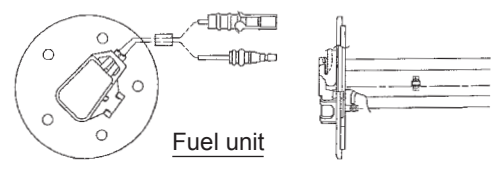

Fuel unit

Starter switch

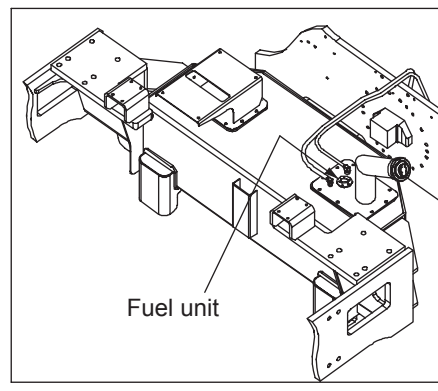

Fuel unit

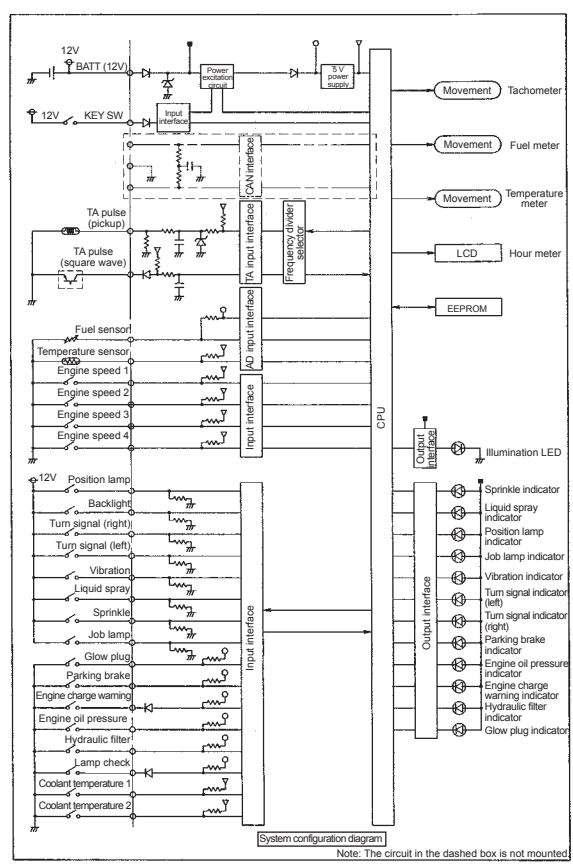

Combination meter circuit diagram

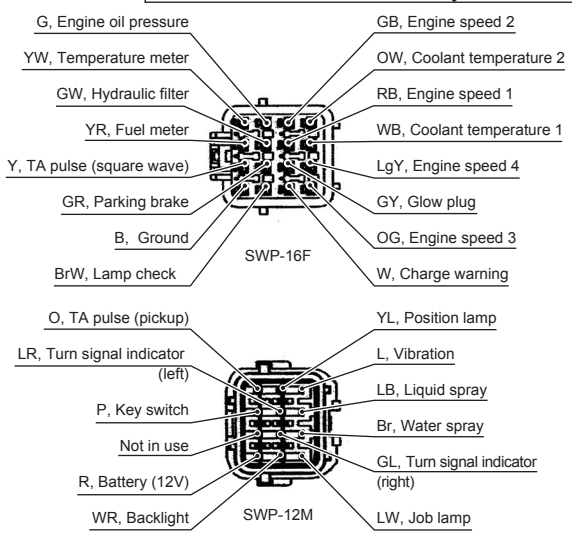

Combination meter connector

SW880-11048

2-9-7. Fuel gauge is abnormal**Reference Fig. : 2-9-5**

Check point	Check/Cause	Action
1. Fuel Unit	<ul style="list-style-type: none"> - Disconnect the harness and measure the resistance of the fuel unit. Standard resistance: 10 Ω (with the float in the full position) 90 Ω (with the float in the empty position) - If the resistance is abnormal, the fuel unit is faulty. 	Replace the fuel unit.
2. Combination Meter	<ul style="list-style-type: none"> - When the starter switch is ON, measure the voltage between the combination meter terminal R wire (battery terminal) and P wire (starter switch terminal) and the ground terminal B wire. Standard voltage: 12V or more - If the above item is OK and no abnormality is found in the fuel unit, the combination meter is faulty. 	Replace the combination meter.
3. Harness Connecting Between Terminals	<ul style="list-style-type: none"> - Measure the resistance of the harness connecting between terminals. Standard resistance: 10 Ω or less - If the resistance is abnormal, the harness is faulty. 	Repair or replace the harness.

2-9-8. Hydraulic oil filter warning lamp remains ON**Reference Fig. : 2-9-5**

Check point	Check/Cause	Action
1. Hydraulic Oil Filter Switch	<ul style="list-style-type: none"> - When the engine is not running, check the continuity between the hydraulic oil filter switch inlet terminal and the chassis ground. There is no continuity in the normal condition. - If there is continuity, the hydraulic oil filter switch is faulty. 	Replace the hydraulic oil filter switch.

Fig. : 2-9-6

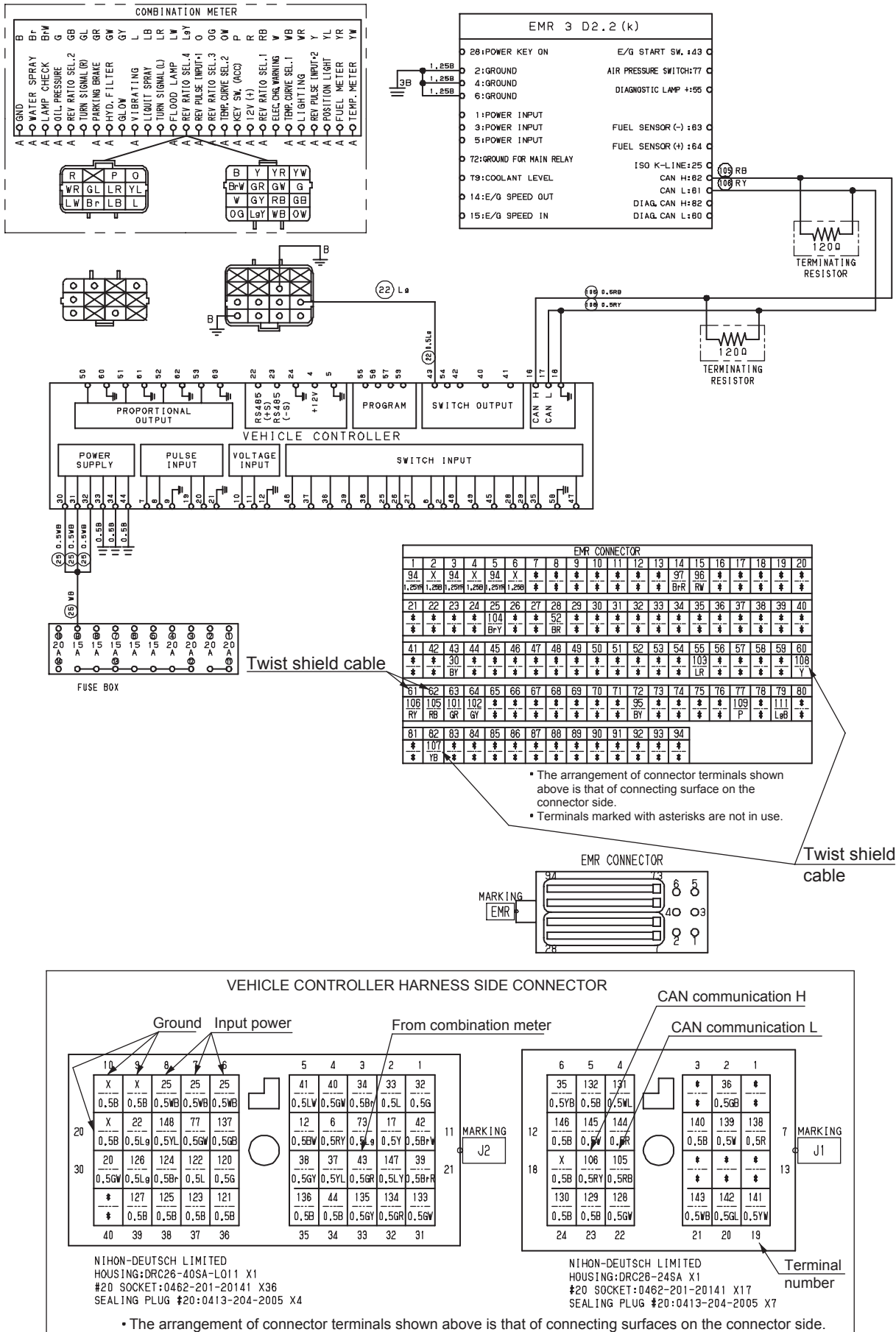

2-9-9. Oil pressure warning lamp remains ON

- Check if the engine check lamp is ON or blinking rapidly.

If so, identify the problem using the “Blink code list” shown in page 11-011.

Reference Fig. : 2-9-6

1) When the display shows any error code

- Check without starting the engine.

Error code	Check point	Check/Cause	Action
E 41	1. Connector	- Check the EMR 3 connector (pins 61 and 62) and vehicle controller connector (pins 16 and 17) for corrosion, breakage, bending and looseness. - If any abnormality is found, the connector is faulty.	Replace the connector or terminal.
	2. Harness	- Measure the resistance between the EMR 3 connector pin 61 RY wire and pin 62 RB wire and the vehicle controller connector pin 17 RY wire and pin 16 RB wire. Standard resistance: 10 Ω or less - If the resistance is abnormal, the harness is faulty. (NOTICE) • Since shielded twisted wires are used for the CAN communication between the vehicle controller and the EMR 3, repair is not approved. Be sure to replace them.	Replace the harness.
	3. CAN Communication	- Faulty CAN communication (NOTICE) • Check if any CAN-related blink code for the engine is issued. If no blink code is issued, the vehicle controller is faulty.	Replace the vehicle controller.

2) When the display shows no error code

- Check without starting the engine.

Check point	Check/Cause	Action
1. Harness	- Disconnect the connectors between the vehicle controller and the combination meter and measure the resistance between the vehicle controller connector pin 43 Lg wire and the chassis ground, and between the combination meter connector pin Lg wire 22 and the chassis ground. Standard resistance: 100 k Ω or more - If the resistance is abnormal, the harness is faulty.	Repair or replace the harness.
2. Combination Meter	- Measure the voltage between the combination meter terminal G wire (oil pressure warning terminal) and the chassis ground. There is no current in the normal condition. - If there is current, the combination meter is faulty.	Replace the combination meter.
3. Vehicle Controller	- Measure the resistance between the vehicle controller connector pin 43 Lg wire and the chassis ground. Standard resistance: 100 k Ω or more - If the resistance is abnormal, the vehicle controller is faulty.	Replace the vehicle controller.

Fig. : 2-9-7

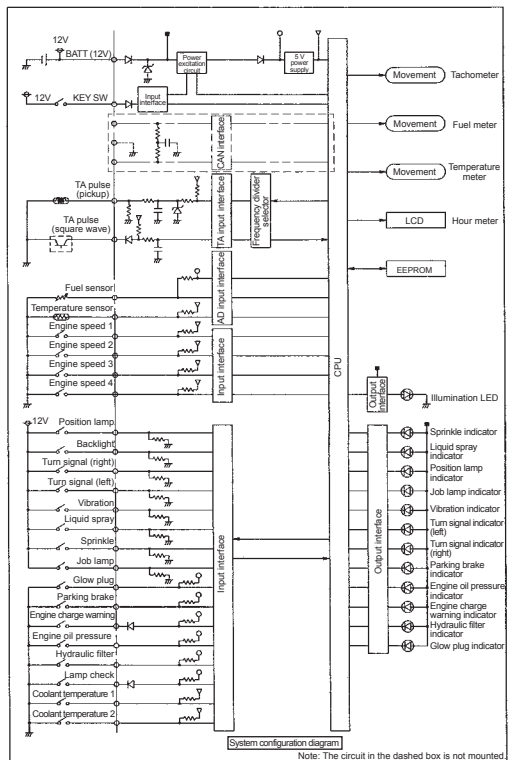
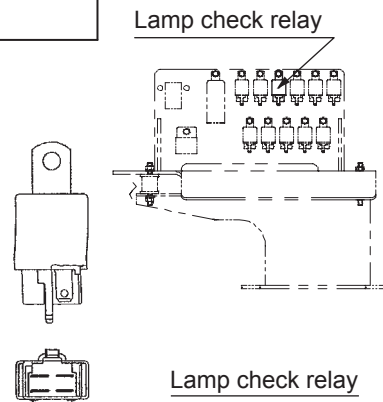
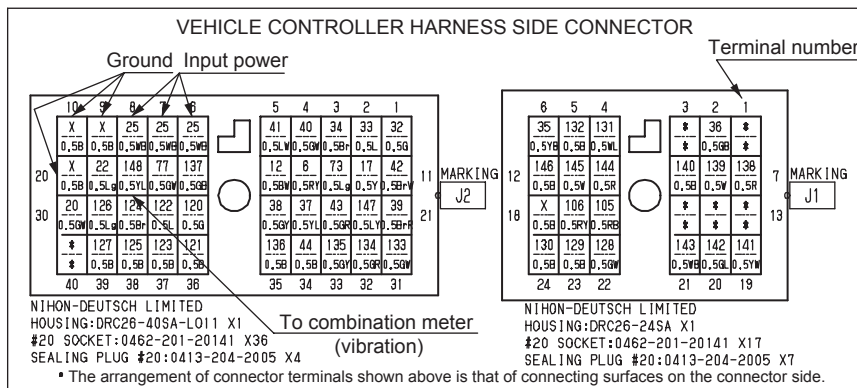
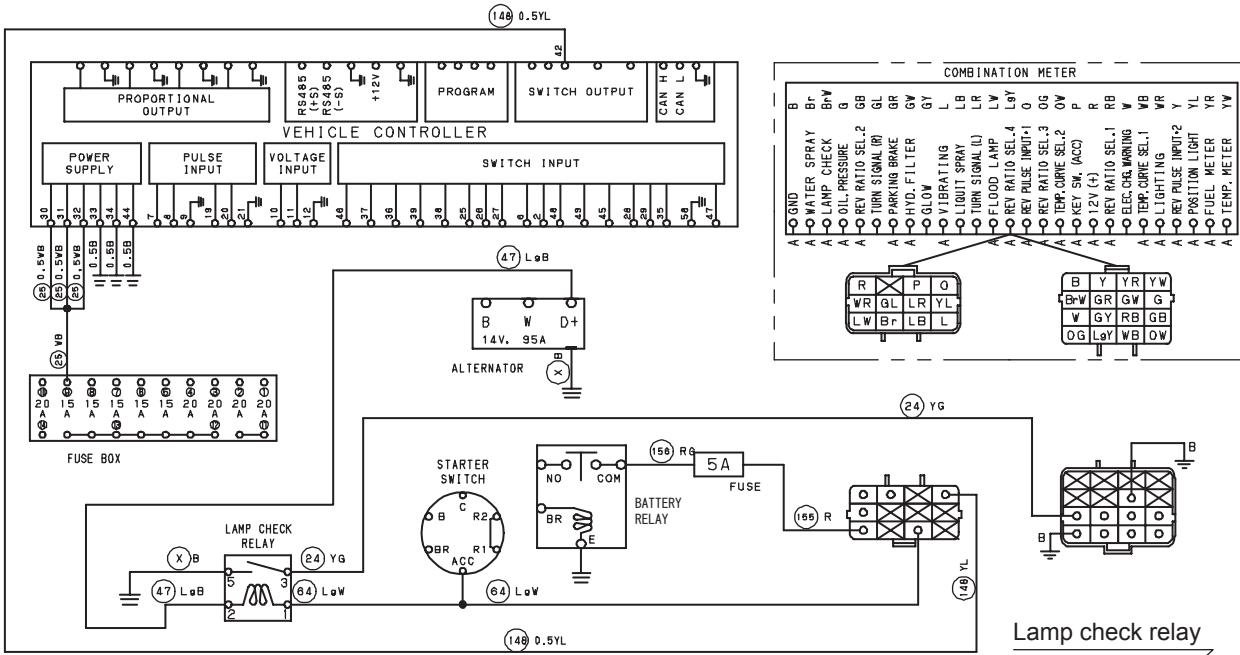

Combination meter circuit diagram

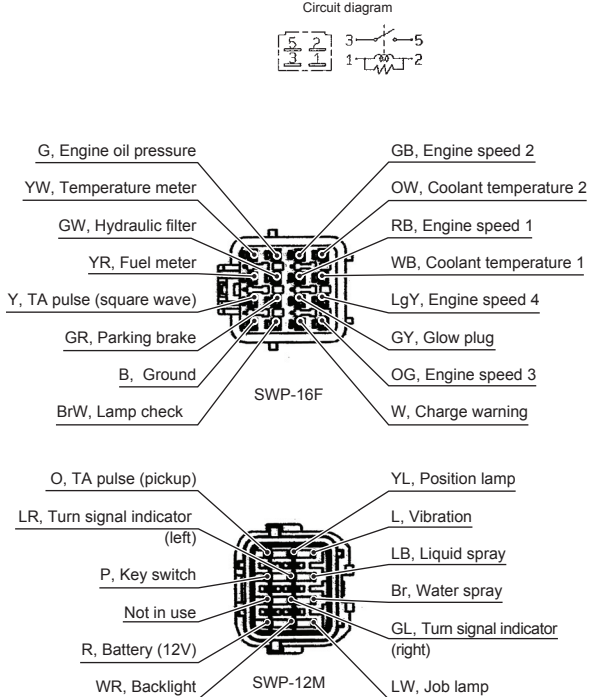

Combination meter connector

2-9-10. Charge warning lamp remains ON

- Check with the engine started.

Reference Fig. : 2-9-7

Check point	Check/Cause	Action
1. Harness	<ul style="list-style-type: none"> - Disconnect the alternator terminal D+ and the lamp check relay pin 2 and measure the resistance between the alternator terminal D+ and chassis ground and the resistance between the lamp check relay pin 2 and the chassis ground. Standard resistance: 100 kΩ or more - If the resistance is abnormal, the harness is faulty. 	Repair or replace the harness.
2. Lamp Check Relay	<ul style="list-style-type: none"> (1) Measure the voltage between the lamp check relay pin 2 and the chassis ground. Standard voltage: 12V or more (2) Measure the voltage between the lamp check relay pin 5 and the chassis ground. There is no current in the normal condition. - If the above item (1) is OK and the item (2) is NG, the lamp check relay is faulty. 	Replace the lamp check relay.

2-9-11. Vibration indicator lamp does not light

- Check that the vibration can be activated.

Reference Fig. : 2-9-7

Check point	Check/Cause	Action
1. Harness	<ul style="list-style-type: none"> - Measure the resistance between the vehicle controller connector pin 42 and the combination meter connector pin YL wire 148. Standard resistance: 10 Ω or less - If the resistance is abnormal, the harness is faulty. 	Repair or replace the harness.
2. Combination Meter	<ul style="list-style-type: none"> (1) When the starter switch is ON, measure the voltage between the combination meter terminal R wire (battery terminal) and P wire (starter switch terminal) and the ground terminal B wire. Standard voltage: 12V or more (2) When the starter switch is turned ON and the vibrator switch is also turned ON, measure the voltage between the combination meter terminal L wire (vibration terminal) and the chassis ground. Standard voltage: 12V or more - If the above items (1) and (2) are OK, the combination meter is faulty. 	Replace the combination meter.
3. Vehicle Controller	<ul style="list-style-type: none"> (1) When the starter switch is ON, measure the voltage between the vehicle controller input power supply pins 30, 31 and 32 and the ground terminals 33, 34 and 44. Standard voltage: 12V or more (2) When the starter switch is turned ON and the vibrator switch is also turned ON, measure the voltage between the vehicle controller output pin 42 and the chassis ground. Standard voltage: 12V or more - If the above item (1) is OK and the item (2) is NG, the vehicle controller is faulty. 	Replace the vehicle controller.

Fig. : 2-9-8

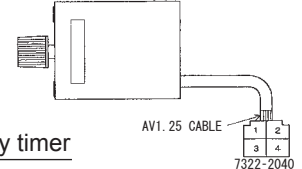
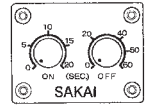
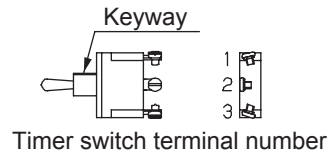
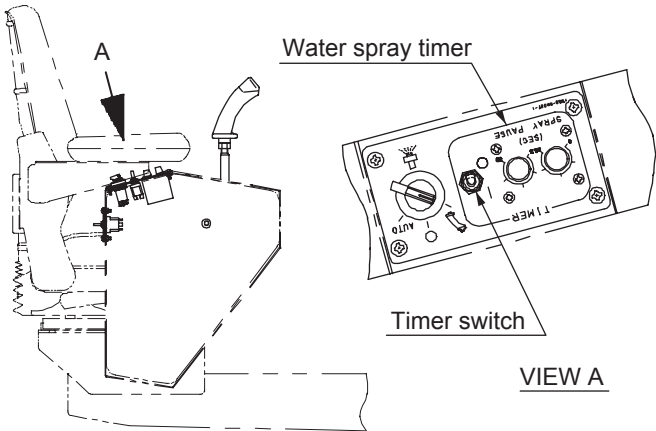
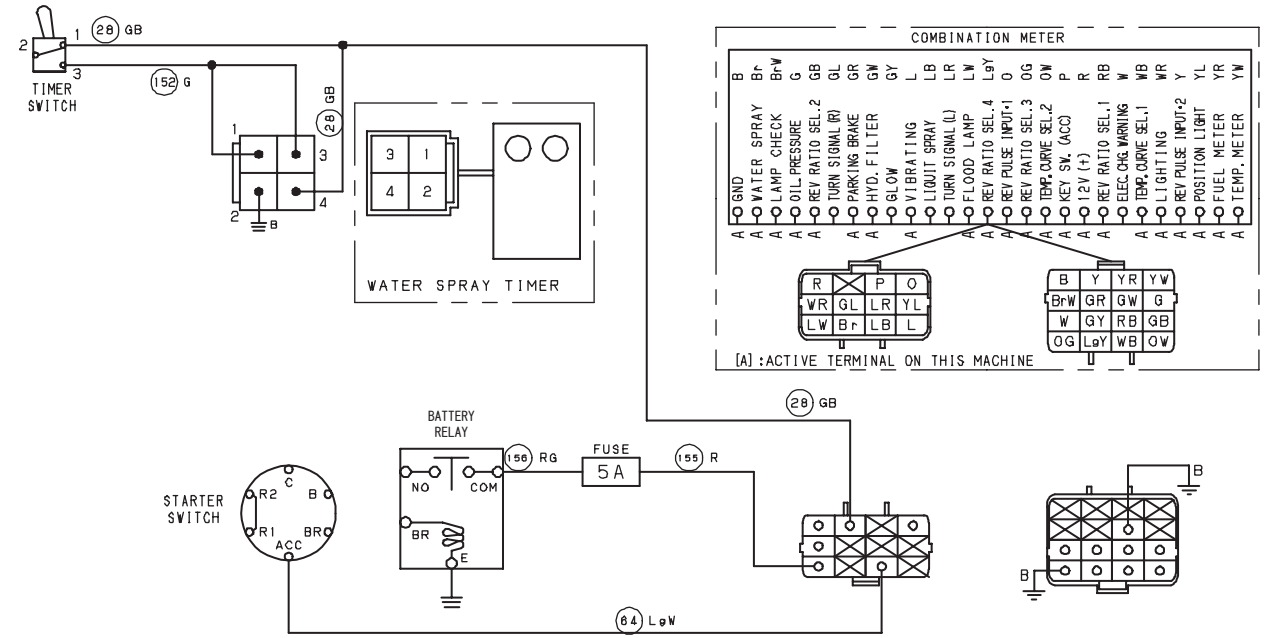

EQUIVALENT ITEM MADE BY YAZAKI
 THE ABOVE SHOWS THE ARRANGEMENT OF CONNECTOR
 TERMINALS ON THE CONNECTING SURFACE.
 <CONNECTOR NO. AND WIRE COLOR>
 1. DC + POWER: RED
 2. DC - POWER: BLACK
 3. OUTPUT + SIDE: BLUE
 4. OUTPUT - SIDE: BLUE

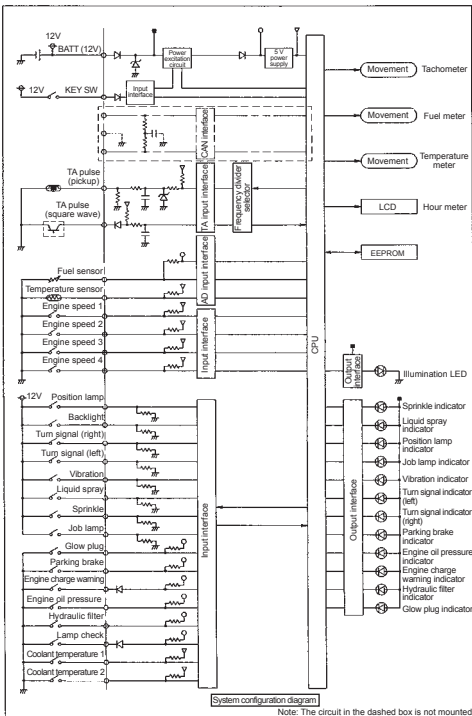

Combination meter circuit diagram

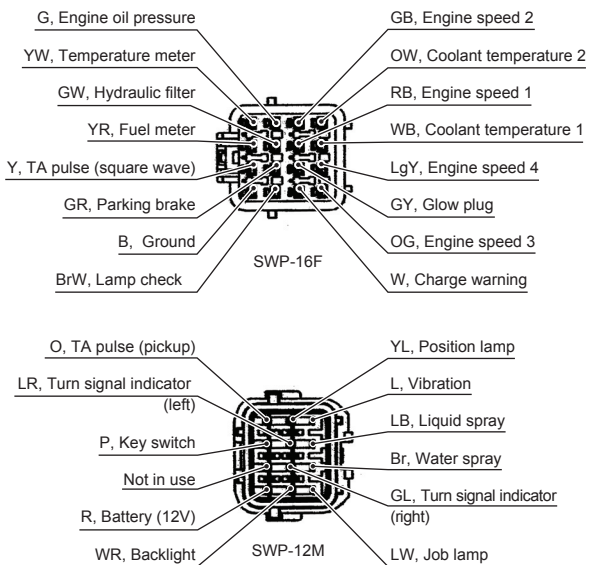

Combination meter connector

2-9-12. Water spray indicator lamp does not light

- Check that the water spray pump can be operated.

Reference Fig. : 2-9-8

Check point	Check/Cause	Action
1. Harness	- Measure the resistance between the timer switch pin 1 inlet GB wire and the combination meter connector pin GB wire 28. Standard resistance: 10 Ω or less - If the resistance is abnormal, the harness is faulty.	Repair or replace the harness.
	- Measure the resistance between the water spray timer pin 4 inlet GB wire and the combination meter connector pin GB wire 28. Standard resistance: 10 Ω or less - If the resistance is abnormal, the harness is faulty.	Repair or replace the harness.
2. Combination Meter	(1) When the starter switch is ON, measure the voltage between the combination meter terminal R wire (battery terminal) and P wire (starter switch terminal) and the ground terminal B wire. Standard voltage: 12V or more (2) When the starter switch is turned ON and the water spray switch is also turned ON, measure the voltage between the combination meter terminal Br wire (water spray terminal) and the chassis ground. Standard voltage: 12V or more - If the above items (1) and (2) are OK, the combination meter is faulty.	Replace the combination meter.

Fig. : 2-9-9

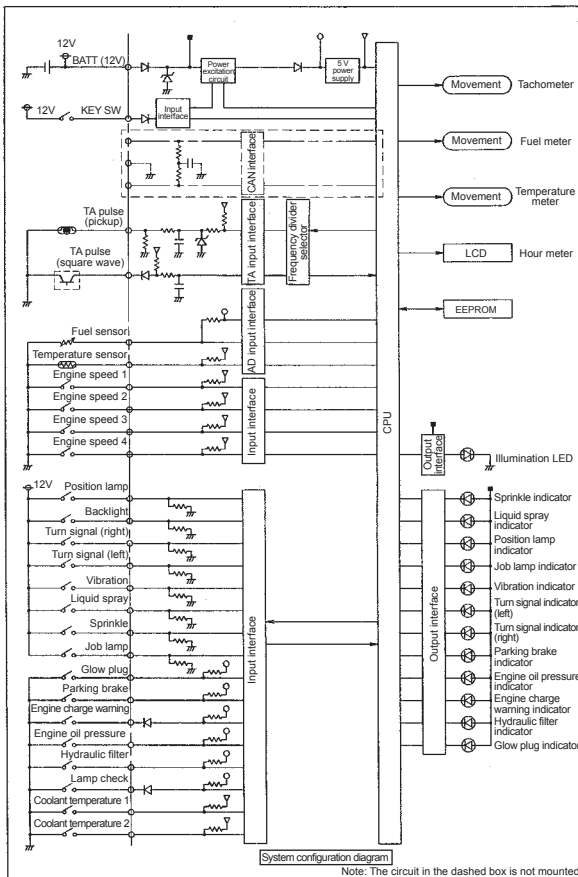
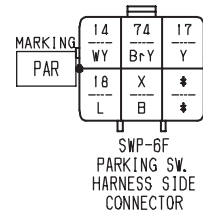
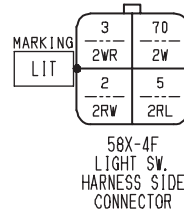
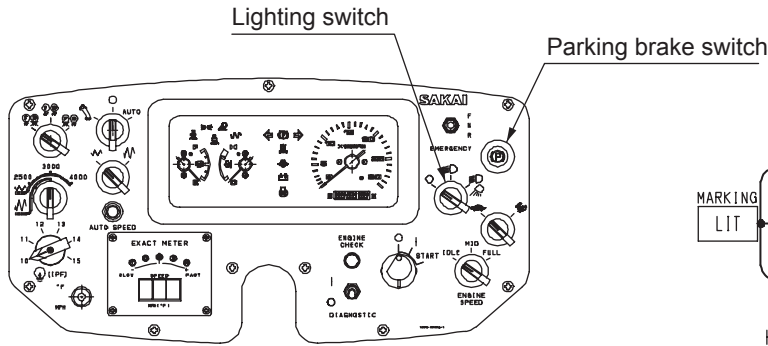
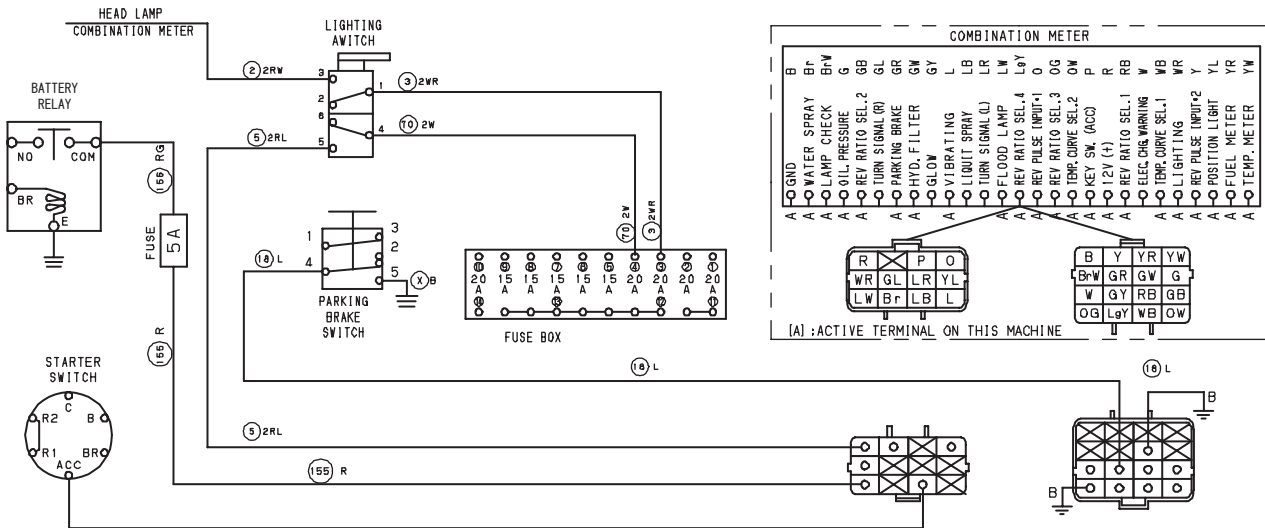

Combination meter circuit diagram

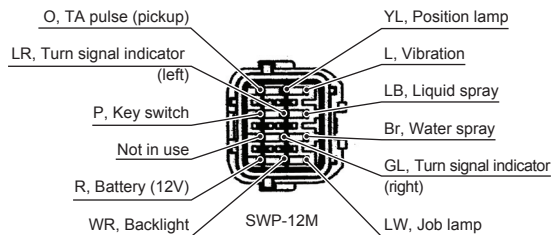
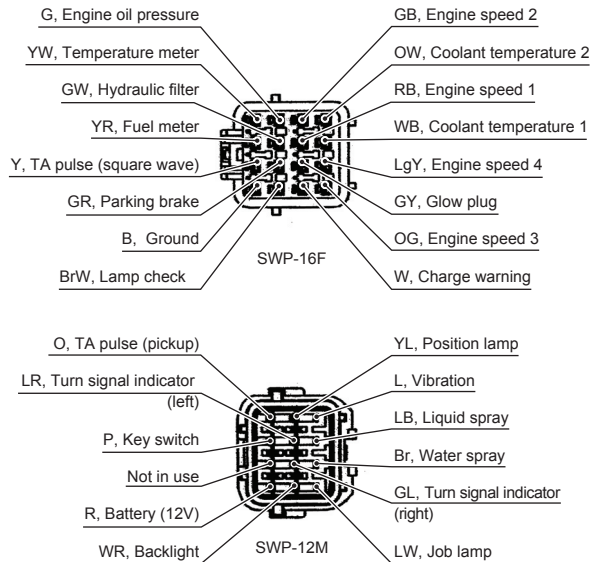

Combination meter connector

2-9-13. Working lamp indicator lamp does not light

- Check that the headlamps and working lamps can be turned on.

Reference Fig. : 2-9-9

Check point	Check/Cause	Action
1. Harness	<ul style="list-style-type: none"> - Measure the resistance between the lighting switch pin 5 inlet RL wire and the combination meter connector pin RL wire 5. Standard resistance: 10 Ω or less - If the resistance is abnormal, the harness is faulty. 	Repair or replace the harness.
2. Combination Meter	<ul style="list-style-type: none"> (1) When the starter switch is ON, measure the voltage between the combination meter terminal R wire (battery terminal) and P wire (starter switch terminal) and the ground terminal B wire. Standard voltage: 12V or more (2) When the starter switch is turned ON and the second stage of the lighting switch is also turned ON, measure the voltage between the combination meter terminal LW wire (working lamp terminal) and the chassis ground. Standard voltage: 12V or more - If the above items (1) and (2) are OK, the combination meter is faulty. 	Replace the combination meter.

2-9-14. Parking brake indicator lamp does not light

Reference Fig. : 2-9-10

Check point	Check/Cause	Action
1. Harness	<ul style="list-style-type: none"> - Measure the resistance between the parking brake switch pin 4 inlet L wire and the combination meter connector pin L wire 18. Standard resistance: 10 Ω or less - If the resistance is abnormal, the harness is faulty. 	Repair or replace the harness.
2. Parking Brake Switch	<ul style="list-style-type: none"> - When the parking brake is turned ON, check the continuity between the parking brake switch pins 4 and 5. There is continuity in the normal condition. - If there is no continuity, the parking brake switch is faulty. 	Replace the parking brake switch.
3. Combination Meter	<ul style="list-style-type: none"> (1) When the starter switch is ON, measure the voltage between the combination meter terminal R wire (battery terminal) and P wire (starter switch terminal) and the ground terminal B wire. Standard voltage: 12V or more (2) When the starter switch is ON, measure the voltage between the combination meter terminal GR wire (parking brake terminal) and the chassis ground. Standard voltage: 12V or more - If the above item (1) is OK and the item (2) is NG, the combination meter is faulty. 	Replace the combination meter.

Fig. : 2-9-10

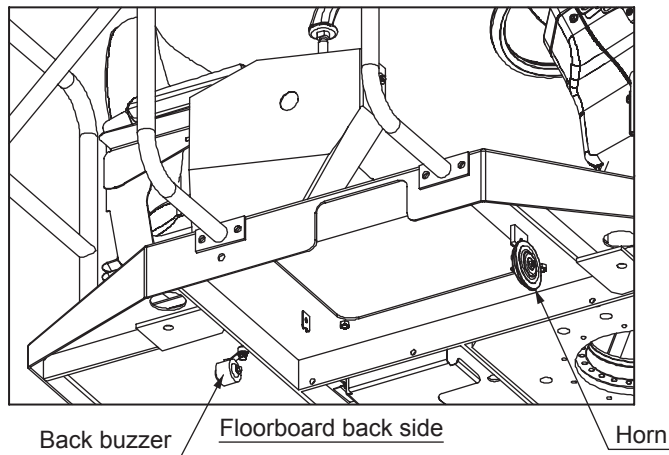
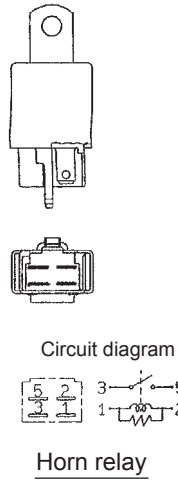
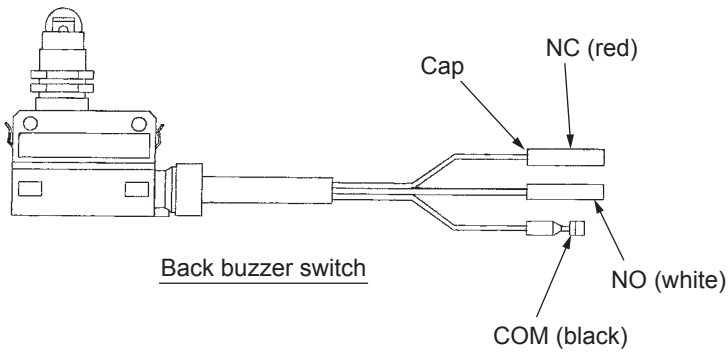
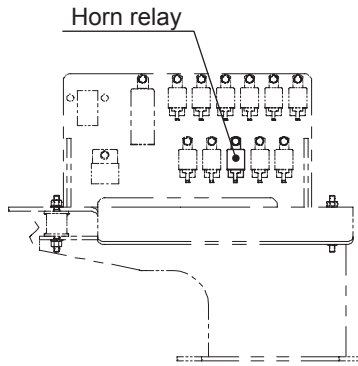
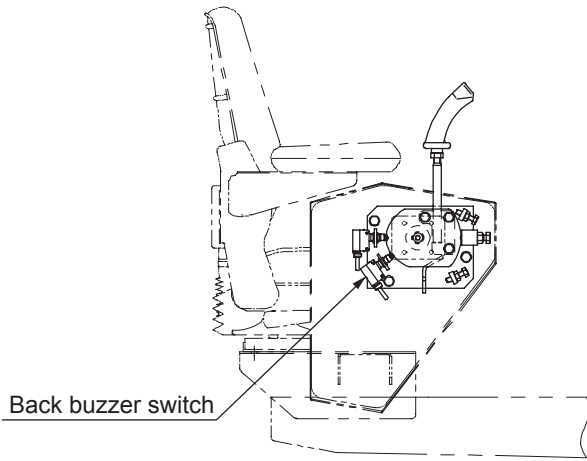
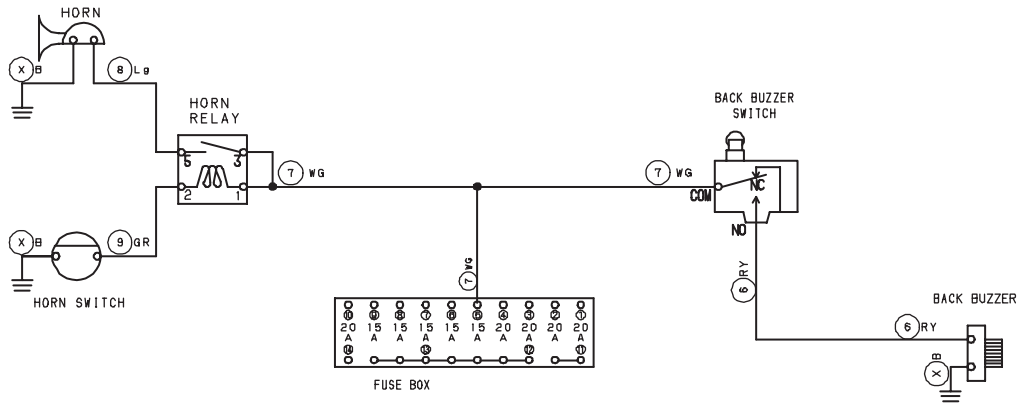

2-9-15. Horn does not sound**Reference Fig. : 2-9-10**

Check point	Check/Cause	Action
1. Horn	- Disconnect the horn and directly connect the battery positive terminal to the horn terminal Lg wire and the negative terminal to the B wire. - If the horn does not sound, the horn is faulty.	Replace the horn.
2. Horn Relay	(1) When the starter switch is turned ON and the horn switch is pressed, measure the voltage between the horn switch relay pin 2 GR wire and the chassis ground. Standard voltage: 12V or more (2) When the starter switch is turned ON and the horn switch is pressed, measure the voltage between the horn switch relay pin 5 Lg wire and the chassis ground. Standard voltage: 12V or more - If the above item (1) is OK and the item (2) is NG, the horn relay is faulty.	Replace the horn relay.
3. Horn Switch	- When the horn switch is OFF, measure the resistance between the horn switch terminals. Standard resistance: 100 Ω or more - If the resistance is abnormal, the horn switch is faulty.	Replace the horn switch.
4. Harness Connecting Between Terminals	- Measure the resistance of the harness connecting between terminals. Standard resistance: 10 Ω or less - If the resistance is abnormal, the harness is faulty.	Repair or replace the harness.

2-9-16. Back buzzer does not sound**Reference Fig. : 2-9-10**

Check point	Check/Cause	Action
1. Back Buzzer	- Disconnect the buzzer and directly connect the battery positive terminal to the buzzer terminal RY wire and the negative terminal to the B wire. - If the buzzer does not sound, the buzzer is faulty.	Replace the back buzzer.
2. Back Buzzer Switch	(1) When the starter switch is ON, measure the voltage between the back buzzer switch COM terminal WG wire and the chassis ground. Standard voltage: 12V or more (2) When the starter switch is ON and the forward-reverse lever is in the reverse position, measure the voltage between the back buzzer switch NO terminal RY wire and the chassis ground. Standard voltage: 12V or more - If the above item (1) is OK and the item (2) is NG, the back buzzer switch is faulty.	Replace the back buzzer switch.
3. Harness Connecting Between Terminals	- Measure the resistance of the harness connecting between terminals. Standard resistance: 10 Ω or less - If the resistance is abnormal, the harness is faulty.	Repair or replace the harness.

3. HYDRAULIC SYSTEM TROUBLESHOOTING

3-1. When Performing Hydraulic System Troubleshooting

- The largest factor in the majority of failures of hydraulic devices operating under conditions of higher pressure and greater precision is the entry of dirt (foreign substances) into the hydraulic circuit. Particular caution is required when supplying hydraulic oil or when disassembling and assembling hydraulic devices.

1) Pay attention to the work environment.

As much as possible, avoid performing tasks such as supplying hydraulic oil, replacing filters and repair work on rainy days, when there is strong wind, or in locations where there is much dust.

2) Disassembly and maintenance work in the field

There is the danger of dust entry when disassembly and maintenance work for hydraulic components is performed in the field. In addition, because performance verification after repairs are completed is difficult, replacement of the entire assembly is preferred. Perform disassembly and maintenance of hydraulic components in a special room protected from dust, and use special testers to verify the performance.

3) Sealing of openings

Use caps, tape, plastic bags or other means to seal the openings of removed pipes and components in order to prevent foreign substances from entering. Never leave the openings exposed or put a shop cloth into them. There is the danger of foreign substances entering or of leaking oil causing environmental contamination.

Do not dispose of waste oil on-site. Either deliver it to the customer and request disposal or take it back with you and dispose of it.

4) Prevent entry of foreign substances when supplying oil.

Take care that foreign substances do not enter when supplying hydraulic oil. Clean the oil supply port and the area around it, as well as the supply pump, oilcan and other items. A more reliable method is to use oil cleaning equipment, which can filter out the contamination that occurred during storage.

5) Change hydraulic oil while the temperature is still high.

All oils, including hydraulic oil, flow more readily when they are warm. Higher temperatures also make it easier to eject the sludge and other substances outside the circuit together with the oil. For these reasons, oil changes should be performed while the oil temperature is high. When changing the oil, it is necessary to drain out as much of the old hydraulic oil as possible. (In addition to the hydraulic oil tank, also drain the oil from the filter and circuit drain plugs.) If old hydraulic oil remains in the system, the contaminants and sludge in the old oil will mix with the new oil and shorten the hydraulic oil lifetime.

3-2. Propulsion

If a problem occurs in the propulsion systems such as the propulsion pump, propulsion motor and brakes, determine the cause and carry out action as required, according to the following general troubleshooting items.

(NOTICE)

- When checking whether or not the pressure is correct, refer to the pressure standard value for each hydraulic circuit.

3-2-1. Vehicle moves neither forward nor backward (1/2)

Check point	Cause	Check/Action
1. Oil Level of Hydraulic Oil Tank	The oil level in the hydraulic oil tank is low.	Fill the tank until the correct oil level is obtained.
2. Bypass Valve	The bypass valve is open.	Close the bypass valve.
3. Propulsion Charge Circuit Pressure	The propulsion pump does not discharge oil because the charge pressure is low.	Measure the charge pressure. If low, check the charge relief valve and then adjust the set pressure or replace the valve.
	The charge pressure decreases due to pressure leakage from the pressure override valve (cut-off valve).	Check and adjust the pressure override valve or, if necessary, replace it.
	Insufficient propulsion charge pump discharge.	Repair or replace the propulsion charge pump.
	The charge pressure decreases due to internal leakage of the solenoid valve connecting the oil supply circuit with the charge circuit. - Brake release solenoid valve	When the solenoid is energized, check if oil flows in the return circuit to the tank. If so, carry out the following action. - Repair or replace the brake solenoid valve.
4. Propulsion Proportional Solenoid Valve	The propulsion pump cannot discharge oil because oil does not flow into the servo cylinder chamber due to a faulty propulsion proportional solenoid valve.	Measure the pressure in the servo cylinder chamber. If the pressure is too low, repair or replace the propulsion proportional solenoid valve.
5. Neutral Solenoid Valve	If the spool of neutral solenoid valve is stuck, the pressure in both sides of the servo cylinder chamber is equalized. This causes the propulsion pump unable to discharge oil.	Measure the pressure in the servo cylinder chambers. If the pressure is equal in both chambers, repair or replace the neutral solenoid valve.
6. Suction Filter for Charge Pump	The charge pump flow is reduced due to a clogged filter.	Clean or replace the suction filter.
7. Propulsion Circuit Pressure	The pump does not discharge oil because the setting pressure of the pressure override valve (cut-off valve) is low.	Measure the propulsion circuit pressure. If low, check the pressure override valve, and then adjust or replace as required.
	The circuit does not obtain the required pressure because the setting pressure of the high-pressure relief valve is low.	Measure the propulsion circuit pressure. If low, check the high-pressure relief valve, and then adjust or replace as required.
8. Propulsion Motor	Internal leakage of the propulsion motor.	Measure the drain quantity from the propulsion motor. If the drain quantity is larger than the standard value, repair or replace the motor.
	Sticking of the disc brakes causes the brakes to remain applied.	Replace the disc brakes.

3-2-1. Vehicle moves neither forward nor backward (2/2)

Check point	Cause	Check/Action
9. Brake Solenoid Valve	Brake remains applied because the spool of the brake solenoid valve does not shift.	Repair or replace the brake solenoid valve.
10. Brake	The brake cannot be disengaged because brake discs in the propulsion motor are stuck.	Measure the brake release pressure. If high, repair or replace brake discs in the propulsion motor.
11. Coupling	Drive torque is not transmitted to the pump due to a faulty coupling.	Replace the coupling.

3-2-2. Vehicle moves in one direction only (forward or backward)

Check point	Cause	Check/Action
1. High-pressure Relief Valve	Low circuit pressure due to incorrect high-pressure relief setting or internal leakage.	Interchange the two high-pressure relief valves. If the faulty condition is accordingly reversed, check and adjust the high-pressure relief valve or, if necessary, replace it.

3-2-3. Slow vehicle speed or small drive force

Check point	Cause	Check/Action
1. Bypass Valve	The bypass valve is slightly open.	Close the bypass valve completely.
2. Charge Circuit Pressure	Stroke of the propulsion pump swash plate is small because the charge pressure is low, decreasing the discharge rate of the propulsion pump.	Measure the charge pressure. If low, check the charge relief valve, and then adjust the set pressure or replace the valve.
	Insufficient charge pump discharge	Repair or replace the charge pump.
	The charge pressure decreases due to internal leakage of the solenoid valve connecting the oil supply circuit with the charge circuit. - Brake solenoid valve	When the solenoid is energized, check if oil flows in the return circuit to the tank. If so, carry out the following action. - Repair or replace the brake solenoid valve.
3. Suction Filter for Charge Pump	The flow rate of the charge pump decreases as well as the charge pressure decreases due to a clogged filter.	Clean or replace the suction filter.
4. Propulsion Motor Inlet Pressure	The propulsion motor inlet pressure is low.	Measure the propulsion motor inlet pressure. If low, check the high-pressure relief valve, and then adjust the set pressure or replace the valve.
5. Internal Leakage of Propulsion Motor	The output of propulsion motor decreases and the number of revolutions decreases due to internal leakage of the propulsion motor.	Measure the drain quantity from the propulsion motor. If the drain quantity is larger than the standard value, repair or replace the motor.
6. Propulsion Pump	The discharge flow rate is insufficient due to efficiency degradation of the propulsion pump.	Measure the discharge flow rate of propulsion pump with a flow meter. If the discharge flow rate is not within the specified range, repair or replace the propulsion pump.

3-2-4. Vehicle does not stop completely with forward/reverse lever in neutral position

Check point	Cause	Check/Action
1. Propulsion Proportional Solenoid Valve	Neutral adjustment for the propulsion proportional solenoid valve is inappropriate.	Check and adjust the propulsion proportional solenoid valve or, if necessary, replace it.
2. Propulsion Pump Servo Cylinder	Faulty propulsion pump servo cylinder or faulty pump swash plate setting.	Replace the propulsion pump.

3-2-5. Propulsion system is overheating

Check point	Cause	Check/Action
1. Oil Level of Hydraulic Oil Tank	The oil level in the hydraulic oil tank is low.	Fill the tank until the correct oil level is obtained.
2. Oil Cooler	Cooling efficiency is reduced due to clogged oil cooler fins.	Clean the oil cooler fins.
3. Flushing Valve	Hydraulic oil in the propulsion closed circuit is insufficiently cooled due to flushing valve shuttle spool sticking.	Repair or replace the flushing valve.
	Hydraulic oil in the propulsion closed circuit is insufficiently cooled because the flushing valve relief setting pressure is excessively high.	Adjust the flushing valve relief setting pressure or replace the flushing valve.
4. Propulsion Circuit Setting Pressure	If the circuit pressure setting is excessively low, the relief valve opens, causing the temperature of the hydraulic oil in the circuit to rise.	Measure the propulsion circuit pressure. If low, increase the relief setting pressure.
	If the load is excessively heavy, the relief valve opens, causing the temperature of the hydraulic oil in the circuit to rise.	Measure the propulsion circuit pressure. If high, decrease the propulsion load.
5. Suction Filter for Charge Pump	The load of the charge pump increases due to a clogged filter, causing the temperature of the hydraulic oil in the circuit to rise.	Clean or replace the suction filter.
6. Charge Line Filter	The charge circuit pressure increases due to clogged filter.	Clean or replace the line filter.

3-2-6. Abnormal noise from propulsion system

Check point	Cause	Check/Action
1. Axle Bearings	The axle bearings supporting the front drum and rear drum are damaged.	Replace the axle bearings.
2. Hydraulic Hose Clamp	Vibrator sound of the hydraulic hose is generated because the clamp securing the hydraulic hose is loose.	Tighten the bolts of the loose hydraulic hose clamp to the specified torque.
3. Suction Filter for Charge Pump	Cavitation is occurring in the charge pump due to a clogged filter.	Clean or replace the suction filter.
4. Charge Circuit Pressure	If the charge pressure is low, the brake cannot be released completely, which causes brake drag.	Measure the charge pressure. If low, check the charge relief valve and then adjust the set pressure or replace the valve.
5. Propulsion Motor	The internal bearing of the propulsion motor is damaged.	Repair or replace the propulsion motor.

3-3. Vibrator System

If a problem occurs in the vibrator systems such as the vibrator pump, vibrator motor and vibrator solenoid valve, determine the cause and carry out action as required, according to the following general troubleshooting items.

(NOTICE)

- **When checking whether or not the pressure is correct, refer to the pressure standard value for each hydraulic circuit.**

3-3-1. No vibration

Check point	Cause	Check/Action
1. Oil Level of Hydraulic Oil Tank	The oil level in the hydraulic oil tank is low.	Fill the tank until the correct oil level is obtained.
2. Vibrator Charge Circuit Pressure	The vibrator pump does not discharge oil due to a low charge pressure.	Measure the charge pressure. If low, check and adjust the charge relief valve or, if necessary, replace it.
	Insufficient discharge rate from the vibrator charge pump.	Repair or replace the vibrator charge pump.
3. Vibrator Proportional Solenoid Valve	The propulsion pump cannot discharge oil because oil does not flow into the servo cylinder chamber due to a faulty vibrator proportional solenoid valve.	Measure the pressure in the servo cylinder chamber. If low, repair or replace the vibrator proportional solenoid valve.
4. Suction Filter for Charge Pump	The flow rate of the vibrator charge pump decreases due to a clogged filter.	Clean or replace the suction filter.
5. Vibrator Circuit Pressure	Necessary circuit pressure cannot be obtained because the setting pressure of the main high-pressure relief valve or port relief valve is too low.	Measure the vibrator circuit pressure. If low, check and adjust the main high-pressure relief valve or port relief valve or, if necessary, replace it.
6. Vibrator Solenoid Valve (for Bypassing)	Vibrator pressure is bypassed because the vibrator solenoid valve spool does not switch.	If the vibrator solenoid valve spool does not switch, repair or replace the vibrator solenoid valve.
7. Vibrator Pump	Insufficient discharge rate from the vibrator pump due to reduced efficiency of the vibrator pump.	Measure the discharge flow rate of the vibrator pump with a flow meter. If the discharge flow rate is not within the specified range, repair or replace the vibrator pump.
	Insufficient pump discharge due to wear of the vibrator pump drive shaft spline.	Replace the vibrator pump.
8. Vibrator Motor	Internal leakage of the vibrator motor.	Measure the drain quantity from vibrator motor. If the drain quantity is larger than the standard value, repair or replace the motor.
	Output torque is not transmitted due to the worn spline of the vibrator motor output shaft.	Replace the vibrator pump.

3-3-2. Only front or rear vibratory drum can vibrate (two-drum vibration cannot be performed)

Check point	Cause	Check/Action
1. Vibrator Solenoid Valve (for Bypassing)	Vibrator pressure is bypassed because the vibrator solenoid valve spool does not switch.	If the vibrator solenoid valve spool does not switch, repair or replace the vibrator solenoid valve.
2. Vibrator Motor	Internal leakage of the vibrator motor.	Measure the drain quantity from the vibrator motor. If the drain quantity is larger than the standard value, repair or replace the motor.
	Output torque is not transmitted due to the worn spline of the vibrator motor output shaft.	Replace the vibrator pump.

3-3-3. Vibrator frequency is too low

Check point	Cause	Check/Action
1. Oil Level of Hydraulic Oil Tank	The oil level in the hydraulic oil tank is low.	Fill the tank until the correct oil level is obtained.
2. Vibrator Charge Circuit Pressure	The vibrator pump does not discharge oil due to a low charge pressure.	Measure the charge pressure. If low, check and adjust the charge relief valve or, if necessary, replace it.
	Insufficient discharge rate from the vibrator charge pump.	Repair or replace the vibrator charge pump.
3. Vibrator Solenoid Valve (for Bypassing)	Vibrator pressure is bypassed due to internal leakage of the vibrator solenoid valve.	Repair or replace the vibrator solenoid valve as necessary.
4. Vibrator Circuit Pressure	Decrease in circuit pressure due to internal leakage in the main high-pressure relief valve or port relief valve.	Measure the vibrator circuit pressure. If low, check and adjust the main high-pressure relief valve or port relief valve or, if necessary, replace it.
5. Internal Leakage in Vibrator Motor	Decrease in vibrator motor rpm due to internal leakage in the vibrator motor.	Measure the drain quantity from the vibrator motor. If the drain quantity is larger than the standard value, repair or replace the motor.
6. Vibrator Pump	Decrease in discharge rate from the vibrator pump due to reduced vibrator pump efficiency.	Measure the discharge flow rate of the vibrator pump with a flow meter. If the discharge flow rate is not within the specified range, repair or replace the vibrator pump.

3-3-4. Amplitude cannot be switched between high and low

Check point	Cause	Check/Action
1. Vibrator Proportional Solenoid Valve	Oil flows into only one servo cylinder chamber due to a faulty vibrator proportional solenoid valve. This causes oil discharge from only one propulsion pump.	Measure the pressure in the servo cylinder chamber. If there is no difference between two chambers, repair or replace the vibrator proportional solenoid valve.
2. Vibrator Pump	Only one vibrator pump discharges oil.	Replace the vibrator pump.

3-3-5. Vibrator does not stop

Check point	Cause	Check/Action
1. Vibrator Proportional Solenoid Valve	Incorrect neutral adjustment for the propulsion proportional solenoid valve	Check and adjust the vibrator proportional solenoid valve or, if necessary, replace it.
2. Vibrator Pump Servo Cylinder	Faulty vibrator pump servo cylinder or incorrect setting of the vibrator pump swash plate	Replace the vibrator pump.

3-3-6. Vibrator system is overheating

Check point	Cause	Check/Action
1. Oil Level of Hydraulic Oil Tank	The oil level in the hydraulic oil tank is low.	Fill the tank until the correct oil level is obtained.
2. Oil Cooler	Cooling efficiency is reduced due to clogged oil cooler fins.	Clean the oil cooler fins.
3. Flushing Valve	Hydraulic oil in the vibrator closed circuit is insufficiently cooled due to flushing valve shuttle spool sticking.	Repair or replace the flushing valve.
	Hydraulic oil in the vibrator closed circuit is insufficiently cooled because the flushing valve relief setting pressure is excessively high.	Adjust the flushing valve relief setting pressure or replace the flushing valve.
4. Vibrator Circuit Setting Pressure	If the circuit pressure setting is excessively low, the relief valve opens, causing the temperature of the hydraulic oil in the circuit to rise.	Measure the vibrator circuit pressure. If low, increase the relief setting pressure.
	If the load is excessively heavy, the relief valve opens, causing the temperature of the hydraulic oil in the circuit to rise.	Measure the vibrator circuit pressure. If high, decrease the vibration load.
5. Suction Filter for Charge Pump	The load of the charge pump increases due to a clogged filter, causing the temperature of the hydraulic oil in the circuit to rise.	Clean or replace the suction filter.
6. Charge Line Filter	The charge circuit pressure increases due to a clogged filter.	Clean or replace the line filter.

3-3-7. Abnormal noise from vibrator system

Check point	Cause	Check/Action
1. Vibrator Bearings	The vibrator bearings supporting the eccentric shaft are damaged.	Replace the vibrator bearings.
2. Hydraulic Hose Clamp	Vibrator sound of the hydraulic hose is generated because the clamp securing the hydraulic hose is loose.	Tighten the bolts of the loose hydraulic hose clamp to the specified torque.
3. Suction Filter for Charge Pump	Cavitation is occurring in the charge pump due to a clogged filter.	Clean or replace the suction filter.
4. Vibrator Motor	The internal bearing of the vibrator motor is damaged.	Repair or replace the vibrator motor.

3-4. Steering

If a problem occurs in the steering systems such as the steering pump and orbitrol, determine the cause and carry out action as required, according to the following general troubleshooting items.

(NOTICE)

- **When checking whether or not the pressure is correct, refer to the pressure standard value for each hydraulic circuit.**

3-4-1. Steering wheel is hard to turn

Check point	Cause	Check/Action
1. Oil Level of Hydraulic Oil Tank	The oil level in the hydraulic oil tank is low.	Fill the tank until the correct oil level is obtained.
2. Orbitrol	The relief valve is open or the setting pressure is low.	Measure the steering circuit pressure. If low, check relief valve and then clean or replace as required.
	Flow to the steering cylinder circuit is insufficient due to leakage from the check valve.	Check the check valve, and then clean or replace as required.
	The spool and sleeve of the orbitrol are contaminated or the clearance is incorrect.	Check the orbitrol, and then clean or replace as required.
3. Steering Circuit Pressure	Pressure in the return circuit from orbitrol increases due to a clogged charging line filter.	Clean or replace the line filter.
4. Steering Cylinder	The cylinder thrust decreases due to internal leakage of the steering cylinder.	Repair or replace the steering cylinder.
5. Suction Filter for Steering Pump	The steering pump discharge rate decreases due to a clogged filter.	Clean or replace the suction filter.
6. Steering Pump	Discharging pressure is insufficient due to efficiency degradation of the steering pump.	Measure the steering circuit pressure. If low, replace the steering pump.
7. Steering Column	The column shaft and orbitrol shaft center are misaligned.	Align the column shaft with the orbitrol shaft center or replace the column shaft.
	The column shaft bearing is worn or damaged.	Repair or replace the column shaft.

3-4-2. Steering response is slow

Check point	Cause	Check/Action
1. Oil Level of Hydraulic Oil Tank	The oil level in the hydraulic oil tank is low.	Fill the tank until the correct oil level is obtained.
2. Orbitrol	Oil is bypassing because the relief valve is open.	Measure the steering circuit pressure. If low, check and adjust the relief valve or, if necessary, replace it.
3. Steering Cylinder	Internal leakage of the steering cylinder	Repair or replace the steering cylinder.
4. Suction Filter for Steering Pump	The steering pump discharge rate decreases due to clogged filter.	Clean or replace the suction filter.
5. Steering Pump	Discharging pressure is insufficient due to efficiency degradation of the steering pump.	Measure the steering circuit pressure. If low, replace the steering pump.

3-4-3. Steering wheel backlash or play is large

Check point	Cause	Check/Action
1. Steering Column	The spline of the column shaft or the orbitrol is worn.	Replace the column shaft or orbitrol.
	The column shaft bearings are worn.	Replace the column shaft bearings.
2. Steering Wheel	The serration (spline) of the wheel or column shaft is worn.	Replace the wheel or column shaft.

3-4-4. Steering system is overheating

Check point	Cause	Check/Action
1. Oil Level of Hydraulic Oil Tank	The oil level in the hydraulic oil tank is low.	Fill the tank until the correct oil level is obtained.
2. Oil Cooler	Cooling efficiency is reduced due to clogged oil cooler fins.	Clean the oil cooler fins.
3. Steering Circuit Setting Pressure	If the circuit pressure setting is excessively low, the relief valve is open, causing the temperature of the hydraulic oil in circuit to rise.	Measure the steering circuit pressure. If low, replace the relief valve.
	If the load is excessively heavy, the relief valve is open, causing the temperature of the hydraulic oil in the circuit to rise.	Measure the steering circuit pressure. If high, decrease the steering load.
4. Suction Filter for Steering Pump	The load of the steering pump increases due to clogged filter, causing the temperature of the hydraulic oil in the circuit to rise.	Clean or replace the suction filter.

3-4-5. Abnormal noise from steering system

Check point	Cause	Check/Action
1. Oil Level of Hydraulic Oil Tank	The pump suction pressure is high because the oil level of the hydraulic oil tank is low, causing cavitation in the steering circuit system.	Fill the tank until the correct oil level is obtained.
2. Air in Steering Circuit	Cavitation is caused by air in the circuit.	Bleed the circuit.
3. Hydraulic Hose Clamp	Vibrator sound of the hydraulic hose is generated because the clamp securing the hydraulic hose is loose.	Tighten the bolts of the loose hydraulic hose clamp to the specified torque.
4. Suction Filter for Steering Pump	Cavitation is occurring in the steering pump due to a clogged filter.	Clean or replace the suction filter.

SAKAI HEAVY INDUSTRIES, LTD.

Head office: 1-4-8, Shiba-Daimon, Minato-ku
Tokyo, Japan

Telephone: Tokyo (03) 3431-9971

Facsimile: (03) 3431-6212