

**⚠ Read this handbook thoroughly and understand the whole information contained before trying to operate, inspect and service your machine!**

**OPERATING &  
MAINTENANCE  
INSTRUCTIONS**

VIBRATING  
ROLLER

MODEL

**SW880**

**SW990**

From SW880 → VSW40 – 10101 ~  
SW990 → VSW41 – 10101 ~

**SAKAI®**

## PREFACE

This operator's manual serves as a guide for the use of your Sakai SW880, SW990 Vibrating Roller for those who are new to the machine, and also for the people who have experience in using the machine and want to refresh their knowledge for the machine.

Read this manual thoroughly and try to fully understand the information before operating your machine. Keep this handbook at hand whenever you do your work.

The main subjects of this manual are:

(1) Basic precautions for safety, (2) Operation, (3) Daily maintenance and (4) Specifications. For operation and maintenance of the engine, refer to the Engine Instruction Manual furnished separately. Descriptions in this manual can differ from the machine instructions of your machine due to the results of the investigation and improvement in its design. If you have any inquiry regarding your Machine or this manual, contact our distributors.

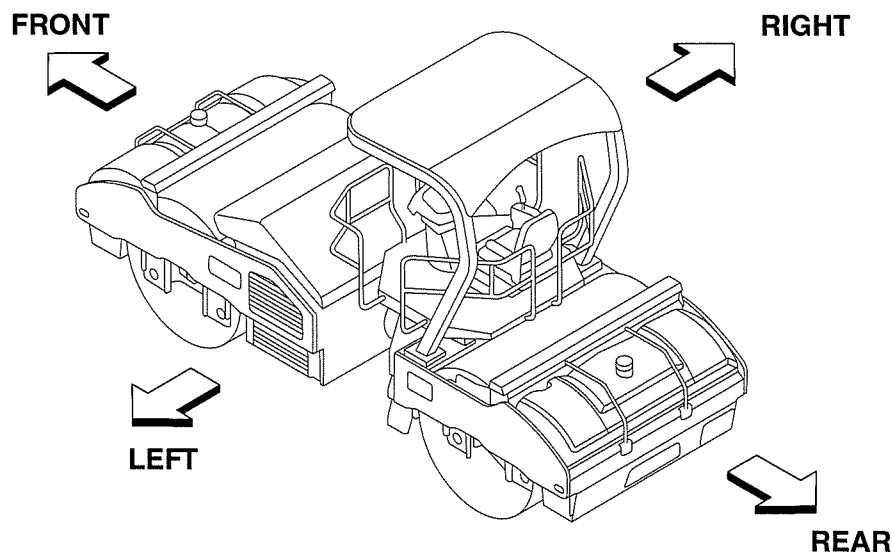

SW880, SW990

**CONTENTS**

## PREFACE

MACHINE AND ENGINE IDENTIFICATION NUMBERS .....	1
SAFETY NOTICES .....	2
<b>1 BASIC SAFETY PRECAUTIONS .....</b>	<b>4</b>
1.1 General Precautions.....	4
1.2 Preparation for Safe Operation .....	6
1.3 Before Starting the Engine .....	7
1.4 After Starting the Engine .....	8
1.5 During Operation .....	8
1.6 Loading and Unloading .....	10
1.7 Transportation .....	11
1.8 Handling the Battery .....	11
1.9 Towing.....	12
1.10 Before Servicing .....	13
1.11 During Servicing .....	14
1.12 Safety Decals .....	16
<b>2 OPERATION.....</b>	<b>18</b>
2.1 Instruments and Controls .....	18
2.1.1 Operator's station .....	18
2.1.2 Gauges, indicator lamps and warning lamps.....	19
2.1.3 Switches .....	22
2.1.4 Operating levers / pedals.....	30
2.1.5 Fuse box and line fuse.....	32
2.2 Handling and Adjustments .....	32
2.2.1 Seat adjustment.....	32
2.2.2 Scraper adjustment or replacement.....	33
2.2.3 Disengaging the brake when towing.....	34
2.2.4 Steering wheel position adjustment .....	35
2.2.5 Operator's platform position adjustment .....	35
2.3 Operation.....	36
2.3.1 Before-starting inspection .....	36
2.3.2 Starting the engine.....	37
2.3.3 After starting the engine.....	38
2.3.4 Engine diagnoses .....	39
2.3.5 Traveling .....	40
2.3.6 Stopping and parking.....	43
2.3.7 AUTO SPEED.....	44
2.3.7.1 Setting.....	44
2.3.7.2 Canceling AUTO SPEED .....	45
2.3.8 Stopping the engine.....	46
2.3.9 Check after stopping the engine .....	46

2.4	Vibratory Operation .....	47
2.5	Water Spray System .....	49
2.6	EXACT COMPACT Operation (Impact Space Indicator & Speed Mater) .....	52
2.6.1	Function .....	52
2.6.2	Operating instruction.....	52
2.6.3	Operation .....	54
2.7	Vehicle Controller Diagnoses .....	55
2.8	Precautions for Work.....	56
2.8.1	Compaction operation.....	56
2.8.2	When going downhill.....	56
2.8.3	On a slope .....	56
2.9	Applicable Jobs .....	56
2.10	After Operation .....	57
2.11	Loading and Unloading .....	58
2.11.1	Use of a trailer equipped with a winch .....	58
2.11.2	Self-propelling .....	59
2.12	After Loading the Machine .....	59
2.13	Transportation .....	60
2.14	Operation in Cold Weather.....	60
2.14.1	Fuel oil and grease .....	60
2.14.2	Coolant .....	60
2.14.3	Battery .....	62
2.15	When the Cold Season is Over .....	62
2.16	For a Long Storage Period .....	63
2.17	During the Storage Period.....	63
2.18	When the Battery has Discharged.....	64
2.18.1	Connection and disconnection of booster cables .....	64
3	PERIODIC MAINTENANCE .....	66
3.1	Precautions .....	66
3.1.1	Lifting the machine on a hoist .....	68
3.2	Walk-around Checking .....	69
3.3	Periodic Maintenance Points.....	70
3.4	Maintenance Procedure .....	72
(1)	Every 10 hours or daily .....	72
(2)	Every 50 hours .....	73
(3)	Every 250 hours .....	74
(4)	Every 500 hours .....	76
(5)	Every 1000 hours .....	77
(6)	As required .....	83
3.5	Fluid and Lubricant Capacities .....	85
3.6	Electric Wiring Diagram.....	87
4	SPECIFICATIONS.....	89

## MACHINE AND ENGINE IDENTIFICATION NUMBERS

When ordering parts or making inquiries about your machine, the following information is requested:

### (1) Machine model

Indicated on the dashboard in the operator's station.

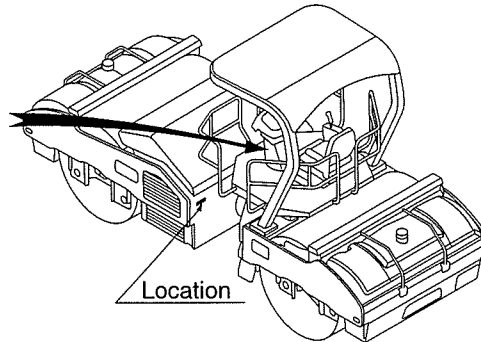
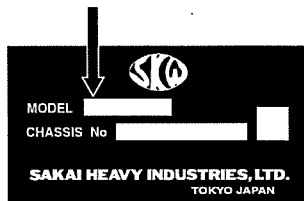

### (2) Machine serial number

SW880 → VSW40 – ○○○○○○  
SW990 → VSW41 – ○○○○○○

### (3) Engine serial number (2 locations)

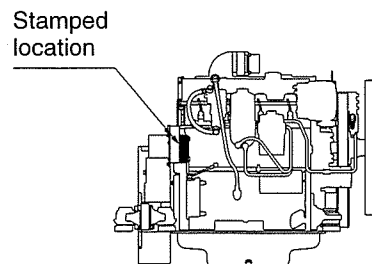
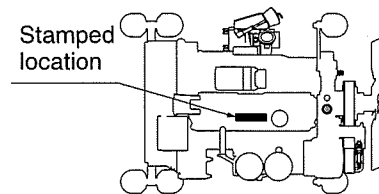







## **SAFETY NOTICES**

For the safe use of your machine, correct handling and periodic maintenance are of utmost importance. Thoroughly read the safety precautions described in this manual. Do not attempt to operate and maintain your machine until you gain a full understanding of these safety statements.

This manual covers the proper and safe method of driving and handling of this machine for its intended use. When this machine is used a manner, other than that covered in this manual, you must assume responsibility for your own personal safety.

In this manual and on the machine, you will find safety notices. Each safety notice starts with a signal word as shown below:

- |  |  |
|--|--|
|  <b>DANGER</b>    | <b>Denotes that there is an extreme hazard. If you fail to take proper precautions, it is highly likely that you could be killed or seriously injured (The color of the symbol  is red).</b> |
|  <b>WARNING</b> | <b>Denotes that there is a hazard. If you fail to take proper precautions, you could be killed or seriously injured (Symbol  is orange).</b>  |
|  <b>CAUTION</b> | <b>Calls attention to safety practices. If you fail to take proper precautions, you could be injured or cause damage to the machine (Symbol  is yellow).</b>                                 |

It is almost impossible for the safety notices in this manual and or the machine to cover all the potential dangers. Keep alert to possible dangers not mentioned in this manual and on the decals.

 **WARNING**

**Do not operate your machine before you read its operator's manual thoroughly.**

**Incorrect operation can kill or cause injury.**

**It is your responsibility to operate the machine safely.**

- ☆ Non-approved modifications can pose safety-related problems. Before making any modifications, consult your distributor. For an injury or damage to the machine caused by non-approved modifications, Sakai accepts no responsibility.
- ☆ Basic precautions for safe operation of your machine are discussed beginning on page 4.
- ☆ To operate and work with your machine, you must be qualified.

## 1. BASIC SAFETY PRECAUTIONS

### 1 BASIC SAFETY PRECAUTIONS

#### 1.1 General Precautions

##### ■ Read the operator's manual thoroughly

- Understand the functions of the controls and gauges. Familiarize yourself with their location and how to operate them. Understand the meaning of all the symbols.



##### ■ Obey the worksite rules

- Follow the worksite rules such as posted warnings, precautions, and hazards. Follow work procedures established for your job site.

##### ■ Wear protective clothing to suit the work

- Wear personal protective equipment such as, but not limited to, hearing protection, safety shoes and hard hat.
- Do not wear loose clothing and accessories that could get caught in the controls or protruded portions of the machine. Do not wear oily clothing.
- According to the type of jobs, wear safety goggles or mask.



##### ■ Know the work area in advance

- Know the terrain, geology and conditions of the road surface at the worksite. Beware of weak spots in the base that could collapse, causing the machine to tip over.

##### ■ Provide against an accident

- Decide in advance the means of communication in an emergency. Know the location and use of a fire extinguisher and first-aid kit.

##### ■ Know the capability of the machine

- Thoroughly understand the performance of your machine and correctly operate the machine to meet the requirements of the job site. Operating the machine beyond its capabilities may lead to an accident. Use your machine within its capability.



**⚠ WARNING:** Negligence of these instructions can lead to accidents.

## 1. BASIC SAFETY PRECAUTIONS

### ■ Do not use a machine which has not been serviced correctly at regular intervals

- Before working, perform necessary inspections. Start operation only after making certain the machine is in good operating condition. If found to be abnormal, report to the responsible person and have the fault corrected. Operate the machine after making sure that it is safe to operate.

### ■ Do not allow anyone to enter the work area except for authorized personnel

- Always conduct the work paying attention to the workers around the machine.



### ■ Be careful of hot parts

- After your machine has operated for some time, the coolant, engine oil and hydraulic fluid will become hot and the pressure will build up. If, in this state, you try to remove the filler caps, drain the oil or replace the filters, you can get burned. Perform this work in accordance with the correct procedures with the machine cooled down.
- To remove the radiator cap, shut off the engine, allow the coolant to cool down, then using a rag to cover the radiator cap, slowly loosen the cap and relieve the pressure. (For the radiator cap with a lever, lift the lever to release the trapped pressure.)
- When removing the filler cap on the hydraulic tank, release the trapped pressure by turning it slowly to prevent the oil from gushing out.
- Do not touch the muffler while the engine is running or immediately after it has been shut down. You can get burned.



### ■ Be careful with fire

- The fuel, oil, and anti-freeze will catch fire if they are exposed to, or come in contact with open flames or ignition sources. Fuel is especially flammable and explosive.
- Do not smoke or use a match or cigarette lighter close to inflammables (combustibles).
- When refueling, stop the engine and do not smoke.
- The filler caps of the fuel and oil tanks must be kept tight.



## **1. BASIC SAFETY PRECAUTIONS**

### **■ Mount on or dismount from your machine after it has come to a complete stop**

- For getting on and off, face the machine and use the handrail and step.
- Do not jump on or off a machine, particularly when it is moving.

### **■ To handle the hydraulic fluid**

- Wear safety goggles to protect your eyes from contact with hydraulic fluid. It can irritate your eyes.  
If the fluid contacts your eyes, flush with clean water for 15 minutes and get medical aid.
- The fluid can also irritate your skin. When handling it, wear rubber gloves to avoid contact with it. In case of skin contact, wash with soap and water.
- Be careful not to swallow the fluid. It can cause diarrhea and emesis.  
If swallowed, do not try to vomit. Get medical help immediately.



## **1.2 Preparation for Safe Operation**

### **■ Clean the step, operator's station and floor board**

- Do not place parts, tools or unnecessary articles on the step, operator's station and floor board.
- Keep the step, floor board, controls and handholds free from muds, oil, ice or water, as they can cause slippage. Repair them if found to be damaged. Tighten loose bolts.
- Keep your boot soles free of oil or muds. They can slip, leading to an accident.

### **■ Inspect your machine before operation**

- Check your machine for damage such as cracks and deformation. If found to be abnormal, operate the machine after taking a proper measure to secure safety.
- Check the level of fluids (fuel, engine oil, coolant, anti-freeze and hydraulic oil). Add as necessary.
- Check the area where the machine has parked for signs of leakage of oil, fuel and water. If any leakage is noticeable, determine the cause and make corrections immediately.

**⚠ WARNING:** Negligence of these instructions can lead to accidents.

## 1. BASIC SAFETY PRECAUTIONS

### ■ Know the stopping distance

- When traveling on a road, bear in mind the stopping distance. Avoid excessive speed, and abrupt starting and stopping, and moving in a zigzag direction.

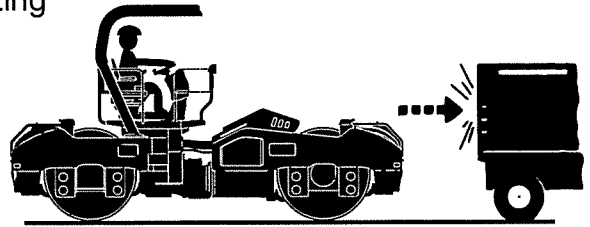

## 1.3 Before Starting the Engine

### ■ Adjust the operator's seat to your most effective operating position

- Sit on the operator's seat. Adjust the seat so that your back will make contact with the seat back when the brake pedal is depressed to the full extent. Check to be sure that the brake pedal can be fully depressed without difficulty when you twist your body for reverse run.

### ■ Secure forward and backward visibilities

- Adjust the rear view mirrors and under mirrors for good visibility. If dirty, clean them. If damaged, replace.

### ■ Check that the horn, lamps and gauges work correctly

### ■ Before starting, make certain that each lever is in the neutral position and the parking brake is applied

### ■ When starting, sound the horn

- Before starting the engine. Make sure there is no one in the immediate vicinity and there are no obstructions around the machine.



## **1. BASIC SAFETY PRECAUTIONS**

### **■ Pay attention to ventilation**

- Exhaust fumes are dangerous if breathed in. When starting the engine in an enclosed area, provide good ventilation with windows and doors opened.

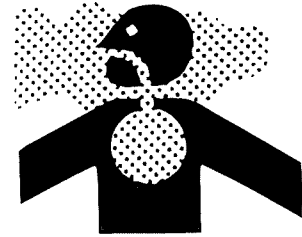

### **■ Do not stand close to the exhaust gas pipe opening**

- Exhaust fumes are noxious if breathed in.

## **1.4 After Starting the Engine**

### **■ Secure safety around the machine**

- Ensure that the area around the machine is clear of personnel and obstructions. Pay particular attention to dead spaces. Before starting, sound the horn.



### **■ Warm up the engine**

- Do not put your machine into motion immediately after the engine has started, let it idle for several minutes until it is at operating temperature.

### **■ Have a trial run**

- Make a test run in a safe place to check that there are no abnormal signs. If found to be abnormal, rectify the fault before traveling again.
- Listen for unusual sounds, and check for abnormal temperature rise. If abnormal, park the machine in a safe location and find the source of trouble before operating.

## **1.5 During Operation**

### **■ No other person but the operator**

- This machine is a one-man roller. Do not allow anyone to get on. Only the operator is allowed on this machine while it is running or in operation. Radios are not permitted.

### **■ Sit in the driver's seat before starting operation**

- Sit in the driver's seat before starting operation. Be sure to wear the seat belt when provided.

### **■ Before mounting, be sure areas around the machine are safe**

- Before getting on the machine, make certain that there are no obstacles around the machine and no workers under it. If some workers are present or close to the machine, tell them that the machine is about to move, warning them to stay away from it.

**⚠ WARNING:** Negligence of these instructions can lead to accidents.

## 1. BASIC SAFETY PRECAUTIONS

### ■ Do not try to get on or off a moving machine

- Get on or off the machine after making sure it has come to a complete stop and the parking brake is applied.

### ■ To go uphill or downhill, run at low speeds. Do not attempt to shift speeds while traveling on a grade

- Shifting speeds on a slope can cause unexpected running down the slope.
- Going down hill at speeds other than low range can cause the machine to run down violently.

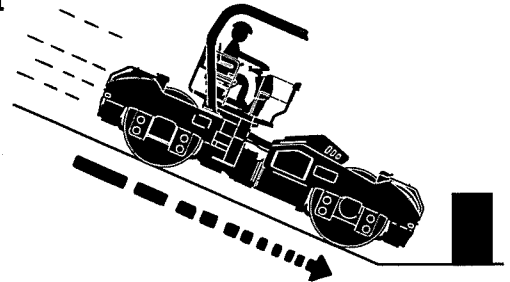

### ■ Refrain from inattentive driving

- Inattentive driving or driving relying on guess work can cause an accident. Use extreme care for workers present in the path of the roller or around it. In case of danger, stop and sound the horn, and proceed when the area is clear of personnel or obstructions.

### ■ When changing the direction of travel, secure the safety on the path in the travel direction

### ■ Keep everyone away from the pinch points

- When making turns, do not allow anyone to come close to the pinch point.

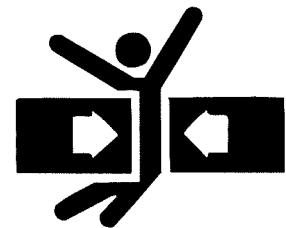

### ■ At night, carefully drive the machine

- Nighttime driving tends to impair the sense of distance. Carefully drive the machine at a speed suited to illumination. Keep the headlamps and flood lamps on. If necessary, provide extra lighting in the work area.

### ■ Repair as soon as possible if found to be defective

- If the machine is found to be faulty, stop the machine and repair it. Do not operate the machine until the problem is corrected. When any warning lamp indicates faulty operation, inspect the machine after moving it to the nearest safe location.

## 1. BASIC SAFETY PRECAUTIONS

- Do not operate the machine except from the operator's seat. Do not drive in a standing posture
- While making turns, do not run at a high speed and do not turn the steering wheel abruptly and sharply. High speed turns, especially on soft or uneven ground, could result in a rollover
- For the traveling on structures such as a bridge, make certain that they can support your machine. Before traveling on the structure, you must know the load capacity of the structure and the load weight of the machine you are operating to ensure safe travel across the structure
- Do not make turns on a slope and do not travel across sidehill. If necessary to do so, go down straight along the slope to the flat ground, move sideways and go up straight to the destination

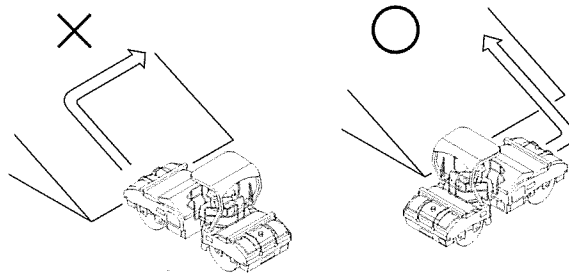

### ■ When parking

- Select level and hard ground. If necessary to park on a slope, block the front of the drums on the downside of the slope.
- When required to park on a public road, provide necessary delineators such as flags, barriers and illumination. However, be sure they do not obstruct traffic.
- When getting off the machine, stop the engine and remove the key from the ignition switch.

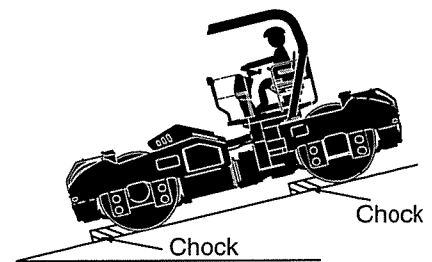

## 1.6 Loading and Unloading

- Loading and unloading can be very dangerous. Use extreme care.
- Select level and hard ground leaving a sufficient distance from the shoulder.
- Use sturdy ramps with proper width, length and thickness which allow safe loading and unloading. If they deflect considerably under load, apply wooden blocks to reinforce the ramps.

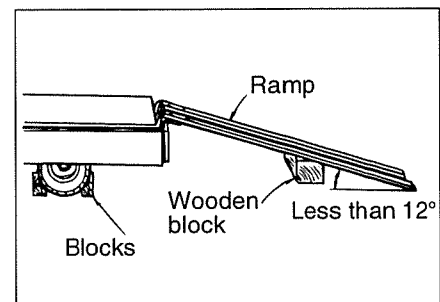

**⚠ WARNING:** Negligence of these instructions can lead to accidents.

## 1. BASIC SAFETY PRECAUTIONS

- To prevent your machine from crosswise slippage, keep the ramps free from oil, mud, debris, etc. The drum must also be free from extraneous matter that can cause slippage.
- Do not steer your machine on the ramps. If the machine is facing in the wrong direction, allow it to dismount from the ramps, correct the direction and try again.
- Do not use kinked, twisted or damaged cables for crane or winch operation. Use cables with ample strength.
- When loading is complete, secure the machine with wooden blocks placed under the drums and chains fastened to the machine.

### 1.7 Transportation

- Follow required regulations.
- Select a transporting route according to the overall width, overall height and gross weight of the trailer with the roller loaded.
- Know the maximum height clearance of the machine loaded on the transport trailer before hauling under bridges and other structures.

### 1.8 Handling the Battery

#### ■ When handling the battery

- Battery electrolyte contains sulphuric acid. It will destroy clothing and skin. If it touches your clothing or skin, flush with large quantities of water.
- In case of eye contact, flush with clean water and seek medical help.
- If swallowed, drink large amount of water, milk, beaten egg or vegetable oil, and get medical help.
- Wear safety goggles when handling the battery. Wear safety goggles, full face shield, rubber gloves and rubber apron when adding fluids to the battery.
- The battery generates flammable gases that can cause an explosion. Do not smoke close to the battery. Keep the battery away from flames, sparks and ignition sources.



#### ⚠ WARNING

**Battery posts, terminals, and related accessories contain lead and lead compounds, chemicals known to the State of California to cause cancer and reproductive harm.  
Wash hand after handling.**

## 1. BASIC SAFETY PRECAUTIONS

- Inspect or handle the battery with the engine shut down and the starter key in the OFF position.
- Keep metallic items such as tools away from the battery terminals.
- Loose terminals can cause sparks leading to an explosion. Secure the terminals tightly.

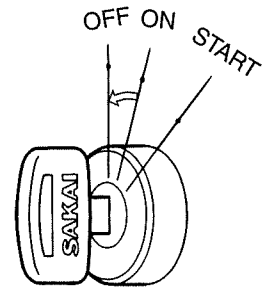

### ■ Jump-starting the engine

- Wear safety goggles when jump-starting the machine.
- When starting from another machine, do not allow the two machines to make contact with each other.
- When connecting the battery cables, start with the positive terminal. For disconnection, start with the negative one.
- Do not allow a tool to bridge and make a connection between the positive terminal and machine body. This can generate dangerous sparks.
- Do not connect the booster cable to wrong terminal. Never connect the positive terminal to the negative.
- Final connection to the engine block of the disabled machine can cause sparks. The connecting point should be as far as possible from the battery.

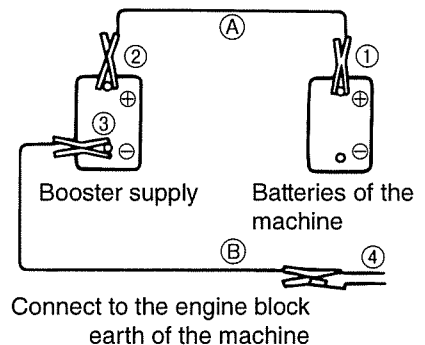
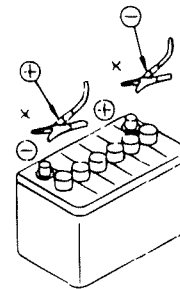

## 1.9 Towing

- To tow the machine, use cables with ample strength.
- Do not perform towing on a slope.
- Do not use twisted, kinked or damaged cables when towing.
- Keep everyone away from the space between the machine and the towing vehicle when connecting the two.
- Align the connection points of the disabled machine and the towing vehicle in a straight line when connecting the machines.



**⚠ WARNING:** Negligence of these instructions can lead to accidents.

## 1. BASIC SAFETY PRECAUTIONS

### 1.10 Before Servicing

#### ■ Attach warning tags when servicing the machine

- Serious accidents can occur if the machine is unexpectedly started or controls carelessly touched by an unauthorized person.
- Attach a warning tag at a clearly visible location in the operator's station and insure the key has been removed from the ignition switch.



#### ■ Use proper tools

- It is very dangerous to use damaged or deteriorated tools or to use tools for purposes other than intended. Use correct tools for their intended use only.



#### ■ Change safety-related parts at regular intervals

- Replace fuel hose and high pressure hydraulic hoses regularly to prevent fire. Replace high pressure hoses of the power steering system every two years.
  - ☆ Change these parts at regular intervals even if found to be normal. They deteriorate over time.
  - ☆ Change any hose found to be abnormal even if it is before its recommended service interval.

#### ■ Inspect or service your machine with the engine stopped

- If required to keep the engine running in such as when flushing the radiator, perform the work with two persons. One person should sit on the operator's seat ready to shut down the engine if necessary. He must take care not to touch any of controls carelessly. Maintenance personnel must exercise extreme caution not to make contact with moving parts.

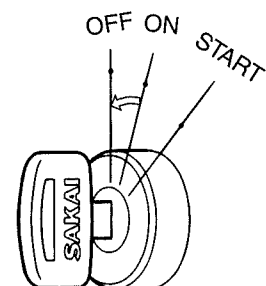

## **1. BASIC SAFETY PRECAUTIONS**

### **■ Supplying fuel and oils**

- Spilled fuel or oil will be slippery. Wipe up immediately. Keep the filler caps tight. Do not use fuel as a flushing oil. Handle fuel and oil in a well ventilated area.

### **■ Check the coolant level in the radiator**

- To check the coolant level, shut down the engine and allow the engine and radiator to cool down before removing the radiator cap. Remove the cap by covering it with a rag before removing to prevent any fluid that could spray under pressure from causing a burn.

### **■ Illumination**

- For inspecting the level of the fuel, oil, coolant and battery electrolyte, use burn-proof illuminations. Failure to use this type of illumination can result in an explosion.

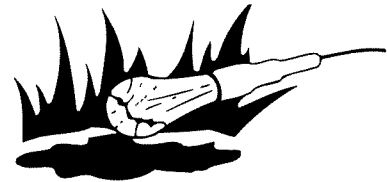

## **1.11 During Servicing**

### **■ Keep unauthorized persons away**

- During service, do not allow persons not concerned to enter the work area, particularly when grinding or welding operation is performed or heavy hammers are being used.



### **■ Keep your machine clean**

- Spilled oil, grease or scattered debris are dangerous. Always keep your machine clean. Moisture that penetrates into the electrical system can cause malfunctions. Do not use water to clean sensors, connectors and the operator's station.

### **■ When repairing the electrical system**

- For repairing the electrical system or for conducting welding, disconnect the negative cable from the battery to shut off the electricity.



### **■ Carefully handle high pressure hoses**

- Do not try to bend or hit hoses against a hard object. Do not use hoses or pipes that are bent or damaged. They will burst.
- Replace damaged fuel hose and hydraulic hoses. An oil or hydraulic fluid spill can cause a fire.

**⚠ WARNING:** Negligence of these instructions can lead to accidents.

## 1. BASIC SAFETY PRECAUTIONS

### ■ Be careful of high pressure hydraulic fluid

- Bear in mind that the working equipment hydraulic systems are under internal pressure. Do not perform adding, draining, inspection or servicing of the hydraulic systems until the internal pressure has been relieved. Hydraulic fluid leaking through a fine hole at high pressure can penetrate your skin and eyes. Inspect any leakage by holding a hard board close to suspected leaks and wear goggles. If skin or eyes are penetrated by high pressure oil, get medical help immediately.

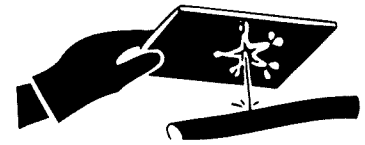

### ■ Be careful of hot parts

- After the machine has been operated for some time, the coolant, engine oil and hydraulic fluid will become hot.
- Removing the radiator cap or draining the coolant or oil can burn you. Perform this work in accordance with correct procedures after the systems have cooled down.

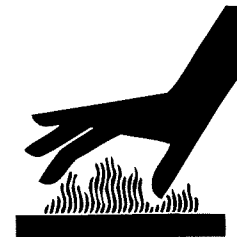

### ■ Use care when inspecting or servicing fan or belts in motion

- Secure loose clothing and keep articles away that could get caught in moving parts.
- Do not let your body or tools make contact with the fan blades or belts. Moving fan belts and blades can cause serious injury or death.



### ■ Used oil disposal

- Do not throw used oil into a drain or waterway. Drain the oil from the machine into a proper container. Do not drain directly on the ground.
- Obey all local, state and federal environment regulations for the proper disposal of oil, fuel, coolant, battery electrolyte or any other fluids.

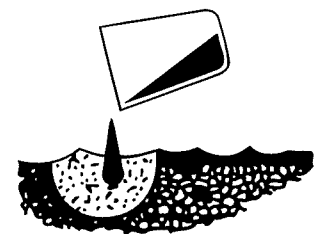

**1. BASIC SAFETY PRECAUTIONS**

**1.12 Safety Decals**

Keep all decals clean. If lost, replace with new one. There are decals other than those shown below: Treat them in the same manner as the one shown here.

① 3998-16504-0

<b>⚠ WARNING</b>
<p><b>1. When Handling the Machine:</b></p> <ul style="list-style-type: none"> <li>Operate only while seated.</li> <li>Use the handrails and steps when boarding and getting off.</li> <li>Never carry passengers.</li> <li>Never attempt to board or get off the machine while it is moving.</li> </ul> <p><b>2. Preparation for Safe Operation</b></p> <ul style="list-style-type: none"> <li>Clean the steps, operator's station and floorboards.</li> <li>Obey the worksite rules.</li> <li>Sakai accepts no responsibility for any injury or damage to the machine caused by unapproved modification.</li> <li>Do not use a machine which needs repair or maintenance.</li> <li>Sound the horn immediately prior to starting the engine to warn people in the vicinity.</li> </ul> <p><b>3. Starting the Engine</b></p> <ul style="list-style-type: none"> <li>Check that all operating levers are in the neutral position.</li> <li>Idle the engine for about 5 minutes to warm it up prior to commencing work.</li> </ul> <p><b>4. Parking Precautions</b></p> <ul style="list-style-type: none"> <li>When parking the machine, park it on level ground, set the parking switch and set the roller chocks.</li> <li>Allow the engine to cool off by running it for about 5 minutes before stopping.</li> <li>When getting off the machine, remove the key from the ignition switch.</li> </ul>
<small>3998-16504-0</small>

⑤ 3998-16502-0

<b>⚠ DANGER</b>	
	<ul style="list-style-type: none"> <li>Do not approach, or allow objects to touch the rotating parts.</li> <li>Body parts which make contact with rotating mechanism will be severed.</li> </ul>
	<ul style="list-style-type: none"> <li>Do not open the radiator cap when fluid is hot.</li> <li>Radiator fluid is flammable. Avoid exposure to flame when radiator cap has been removed.</li> </ul>
	<ul style="list-style-type: none"> <li>Avoid contact with machine parts in the vicinity of the engine while engine is running and after it has been stopped. Contact with hot part will cause burns.</li> </ul>
<small>3998-16502-0</small>	

⑨ 3998-06139-0

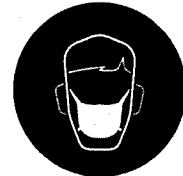

⑩ 3998-16510-0

<b>⚠ CAUTION</b>
<p>Refill the specified quantity of oil in the vibrator case when changing oil.</p>
<small>3998-16510-0</small>

② 3998-16499-0

<b>⚠ WARNING</b>
<ul style="list-style-type: none"> <li>Do not open the hood with the engine running.</li> <li>Contact with hot parts will cause burns.</li> <li>Contact with rotating parts will cause severe injury.</li> </ul>
<small>3998-16499-0</small>

⑥ 3998-16505-0

<b>⚠ DANGER</b>	
	<p><b>Roll Over Prevention</b></p> <ul style="list-style-type: none"> <li>Do not work in the vicinity of overhanging banks, or on grades steep enough to cause the machine to slide or roll over.</li> <li>Reduce speed prior to making turns.</li> <li>Pay particular attention when operating on uneven surfaces, as the machine may become unstable.</li> </ul>
	<small>3998-16505-0</small>

⑪ 3998-16507-1

<b>⚠ CAUTION</b>
<p>Lubricate all grease fittings daily prior to commencing work.</p>
<small>3998-16507-1</small>

⑦ 3998-36002-0 (2 locations)



⑫ 3998-16489-0

<p><b>CALIFORNIA</b> Proposition 65 Warning</p> <p>Diesel engine and some of its constituents are known to the State of California to cause cancer, birth defects, and other reproductive harm.</p>
<small>3998-16489-0</small>

③ 3998-16500-0

<b>⚠ WARNING</b>
<ul style="list-style-type: none"> <li>Avoid inhalation of exhaust gas.</li> <li>Avoid contact with exhaust pipe while engine is running and after it has been stopped. Contact with hot exhaust pipe will cause burns.</li> </ul>
<small>3998-16500-0</small>

⑬ 3998-16547-0(4 locations)

<b>⚠ WARNING</b>
<p>Take care to avoid pinching of hands or fingers when closing this cover.</p>
<small>3998-16547-0</small>

⑧ 3998-16501-0

<b>⚠ DANGER</b>	
<p><b>Be Careful with Fire</b></p> <ul style="list-style-type: none"> <li>When refueling, stop the engine and do not smoke.</li> <li>The filter cap of the fuel tank must be kept tight.</li> </ul>	
<small>3998-16501-0</small>	

⑭ 1568-19011-1

<b>⚠ WARNING</b>
<p>1. This vehicle may malfunction from a strong electromagnetic wave in its neighboring environment. Control is maintained using electronics. Do not use this vehicle in an environment that may expose it to a strong electromagnetic wave. Do not use a device with a strong electromagnetic wave on or near this vehicle.</p> <p>2. Electronics on this vehicle emit a minor electromagnetic wave. Do not operate this vehicle if you wear a pacemaker. Long term operation may cause damage to your health from the electromagnetic wave.</p>
<small>1568-19011-1</small>

④ 3998-16497-1

<b>⚠ WARNING</b>
<ul style="list-style-type: none"> <li>Thoroughly read the operator's manual before using the machine.</li> <li>Incorrect operation can cause severe injury or death.</li> <li>It is your responsibility to operate the machine safely.</li> </ul>
<small>3998-16497-1</small>

⑮ 2998-96001-1

<b>⚠ CAUTION</b>
<p><b>USE SPECIFIED FUEL ONLY</b></p> <ul style="list-style-type: none"> <li>Use of other than the specified fuel may result in damage to the engine.</li> <li>Please refer to the manual for details.</li> </ul>
<small>2998-96001-1</small>

**⚠ WARNING:** Negligence of these instructions can lead to accidents.

**1. BASIC SAFETY PRECAUTIONS**

SW880, SW990

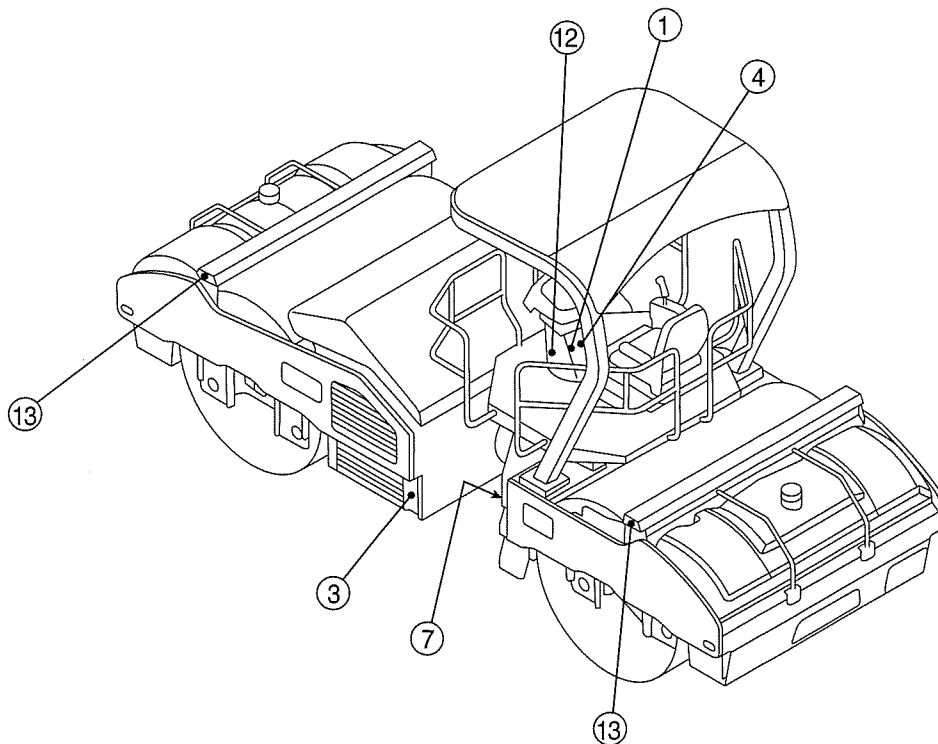
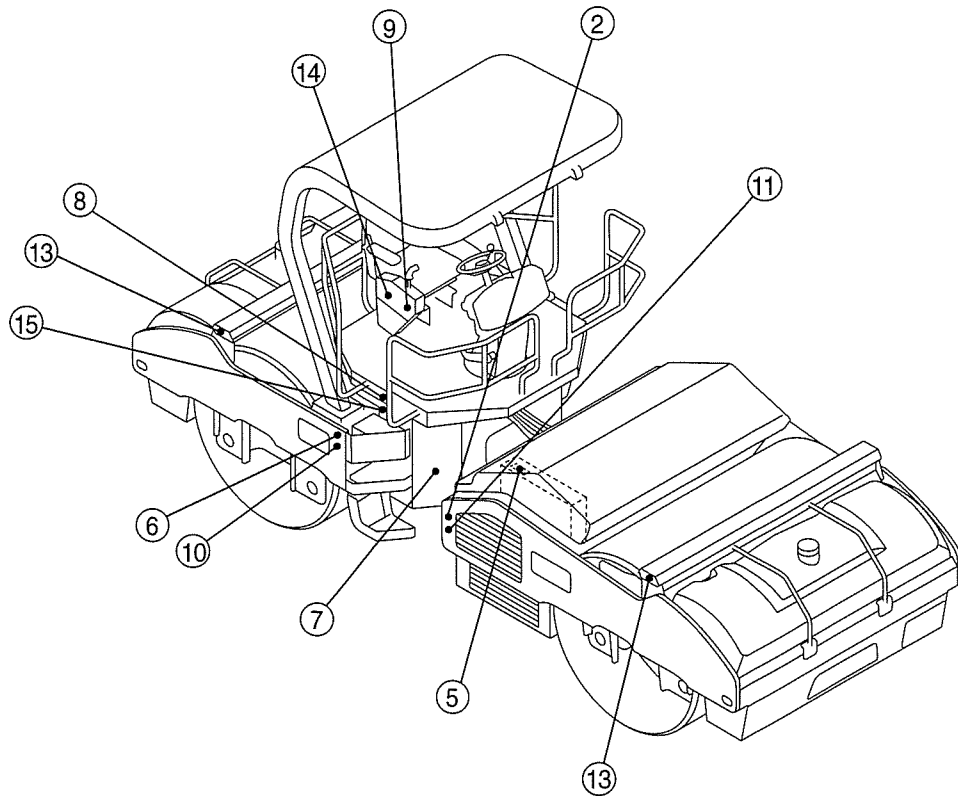

## 2. OPERATION

### 2 OPERATION

#### 2.1 Instruments and Controls

##### 2.1.1 Operator's station

NOTE:

\*marked switches are responded only when the F-N-R lever is in the neutral position.

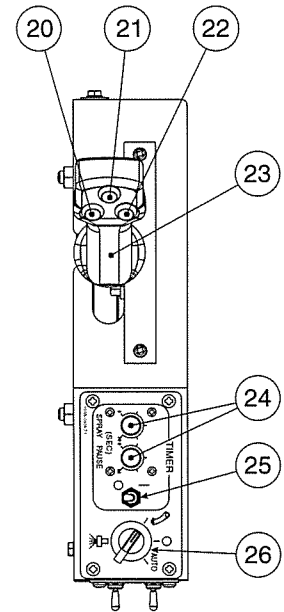
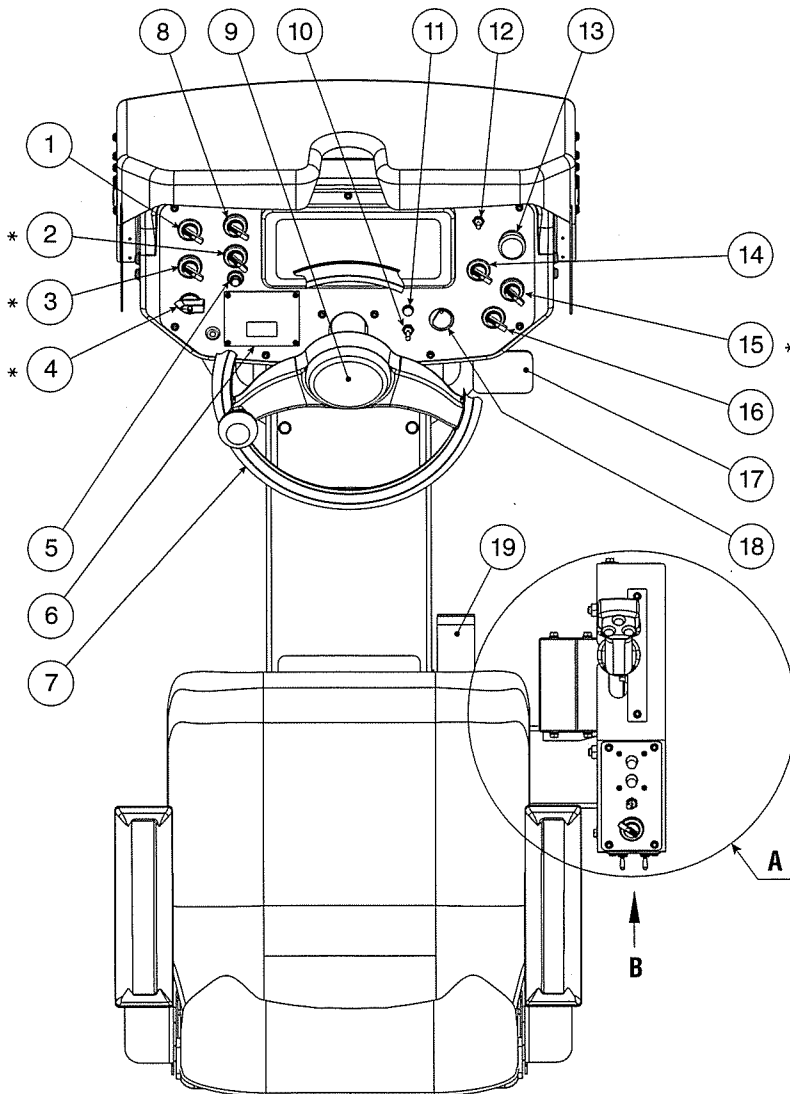

DETAIL A

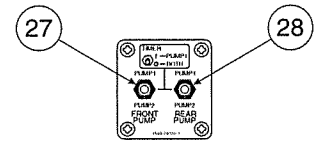

VIEW B

- |  |  |
|--|--|
| ① Vibration drum selector switch                             | ⑮ Propel speed selector switch                           |
| ② Vibration amplitude selector switch                        | ⑯ Engine speed selector switch                           |
| ③ Vibration frequency selector switch                        | ⑰ Brake pedal  |
| ④ IPF selector switch  | ⑱ Starter switch   |
| ⑤ AUTO SPEED indicator lamp                                  | ⑲ Swivel release pedal                                   |
| ⑥ EXACT COMPACT METER  | ⑳ Vibration switch                                       |
| ⑦ Steering wheel   | ㉑ AUTO SPEED set switch                                  |
| ⑧ Vibration mode selector switch<br>(Manual or Auto control) | ㉒ Spray switch   |
| ⑨ Horn switch button   | ㉓ Forward-Neutral-Reverse lever (F-N-R lever)            |
| ⑩ Engine diagnostic switch                                   | ㉔ Spray timer dial                                       |
| ⑪ Engine check lamp  | ㉕ Spray timer switch                                     |
| ⑫ Emergency propel switch                                    | ㉖ Spray mode selector switch<br>(Manual or Auto control) |
| ⑬ Parking brake switch                                       | ㉗ Front spray pump selector switch                       |
| ⑭ Lamp switch  | ㉘ Rear spray pump selector switch                        |

### 2.1.2 Gauges, indicator lamps and warning lamps

For safe execution of your job, fully understand the role and function of the systems involved.

#### Combination meter

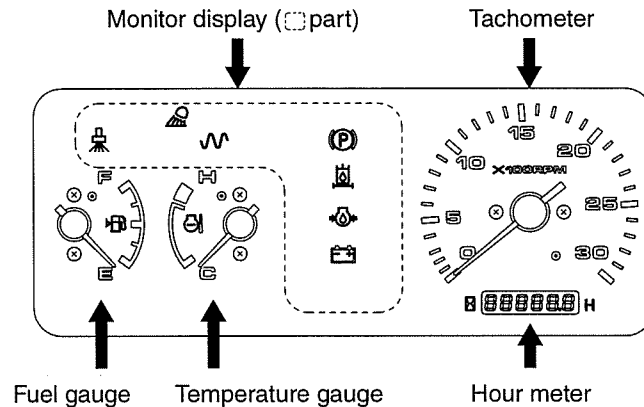

#### Tachometer / Hour meter

Indicates the engine RPM. The hour meter shows total operating hours. The service interval recommendation in this manual should be based upon the hour meter readings.

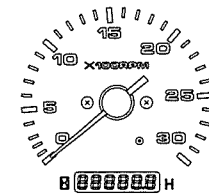

Tachometer / Hour meter

#### Temperature gauge

Indicates the coolant temperature. Zone close to symbol H indicates overheating. In case of overheating, run the engine at idling for about ten minutes before shutting it down. Then determine the cause.

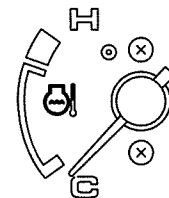

Temperature gauge

#### Fuel gauge

Indicates the fuel level in the tank.

- E: The tank is empty.
- F: The tank is full.

Replenish fuel appropriately before the fuel runs down.

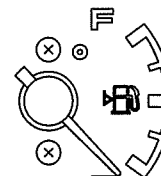

Fuel gauge

#### **CAUTION**



Be sure to use fuel recommended by SAKAI (refer to page 86).

## 2. OPERATION

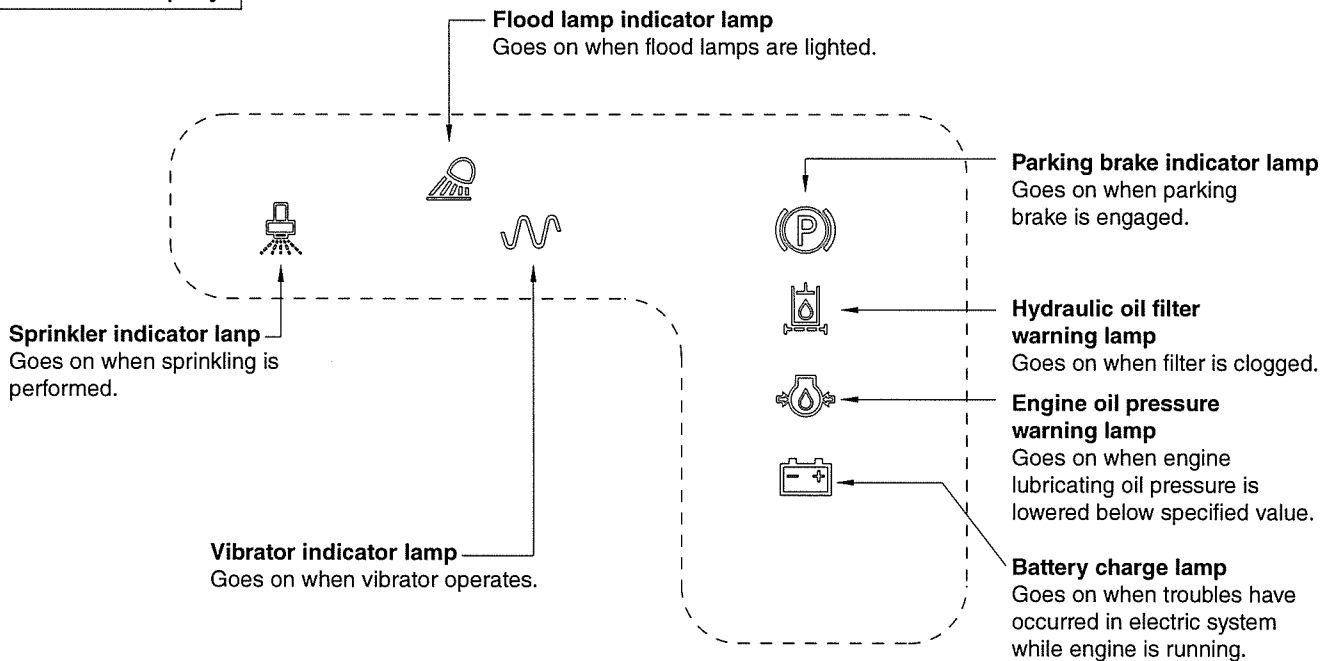
### Monitor display



★ Indicator lamps [ (P)    ]  
Light up when corresponding systems are operating.

★ Warning lamps [    ]  
Go on when the starter switch is turned to the ON position and go off when the engine has started. If any light up while the engine is running, this indicates a faulty condition. Stop the engine and trace the source of trouble.

= Checking for warning lamp and parking brake indicator lamp =  
They should turn on light when the starter switch in ON position.  
If not, there is some trouble.  
Check and repair the combination meter or wiring harness.

=The window of the combination meter=  
The window of the combination meter may become invisible because of aged deterioration caused by fine sand or dust or ultraviolet ray. When any flaw or mist is found on the window, contact our branch offices or designated factory.

### ⚠ CAUTION

- Hydraulic oil filter warning lamp may go on when the engine rpm is increased before the engine has been warmed up enough. Keep the engine idling until the lamp goes off, before starting your work.
- The window of the combination meter may become invisible because of aged deterioration caused by fine sand or dust or ultraviolet ray. When any flaw or mist is found on the window, contact our branch offices or designated factory.



Engine check lamp

- Lamp check : The lamp lights up for approx. 2 sec. after switching on the starter switch.
- Steady Light : A system error or an engine variable value (temperature or pressure etc.) is in the warning range is occurred.  
See 2.3.4 Engine Diagnosis Page 39.
- Fast flashing : The engine is in danger condition. Stop the vehicle immediately as soon as it is safe to do so.  
See 2.3.4 Engine Diagnosis Page 39.

ENGINE CHECK



**IMPORTANT**

**When the engine malfunctions or fails, contact your SAKAI Dealer immediately for appropriate diagnosis inspection, maintenance, or repair.**

AUTO SPEED lamp

- Steady light : Goes on when the “ AUTO SPEED ” is selected by pressing the “ AUTO SPEED ” button.
- Slow flicker : Goes on when the “ AUTO SPEED ” is cancelled by pressing the “ AUTO SPEED ” button.
- Fast flicker : Goes on when the either of “ IPF ” “ Propel speed ” “ Vibration frequency ” “ Vibration amplitude ” “ Engine speed ” position is changed while in the “ AUTO SPEED ” mode.



AUTO SPEED

EXACT COMPACT METER

Impact frequency lamp  
The lamp flashes depending on the rolling speed and IPF setting.

Rolling speed  
or  
Error codes  
or  
Temperature Display

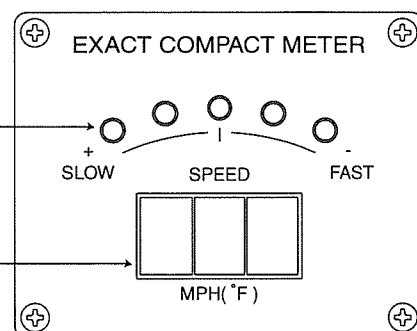

## 2. OPERATION

### 2.1.3 Switches

#### Starter switch

Starts and stops the engine.

**OFF** : The key can be removed in this position. All the electric systems are switched off. To shut down the engine, move the key to this position.

**ON** : The charging circuit and lamp circuit are charged with electricity. Leave the key in this position after the engine has started.

**START** : The engine is cranked and gets started. The moment the engine has started, release the key. It will automatically return to the ON position.

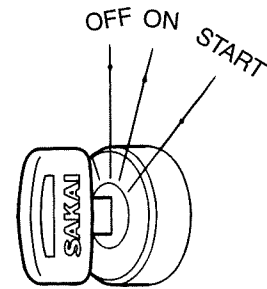

#### ⚠ CAUTION

**Set the forward-reverse (F-R) lever in the neutral position and press down the parking brake switch before starting the engine. Unless these conditions are met, the engine will not start.**

#### Lamp switch

- position : All lamps are switched off.
- ☹ position : Illuminates the dash panel and front lamps go on.
- ☹☹ position : All lamps are switched on.

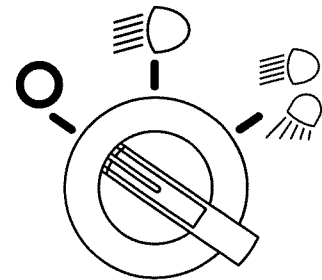

#### Engine speed selector switch

Selects engine speed.

**IDLE** position : Warm up the engine

**MID** position : Propel the vehicle (travel mode without vibration)

**FULL** position : Propel the vehicle with vibration

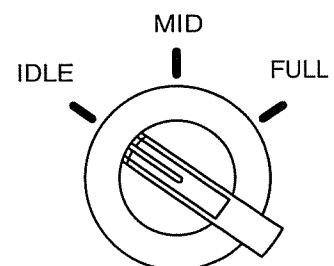

Parking brake switch

If switch (P) is pressed down, the parking brake will be applied with the indicator lamp (P) on the dashboard lit up.

When pressed again, the brake is released and the indicator lamp goes off.

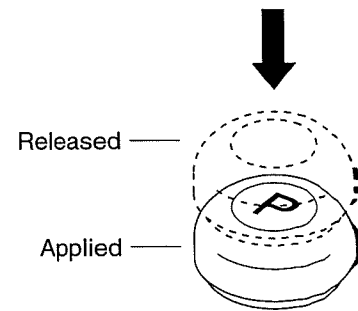

**⚠ WARNING**

- To disengage the brake, be sure to press the button again instead of pulling it.
- Always press the button to apply the parking brake before dismounting from the machine.

**⚠ CAUTION**

Never pull the switch up.

**IMPORTANT**

In an emergency, depress the brake switch.

Horn switch button

Pressing the button at the center of the steering wheel sounds the horn.

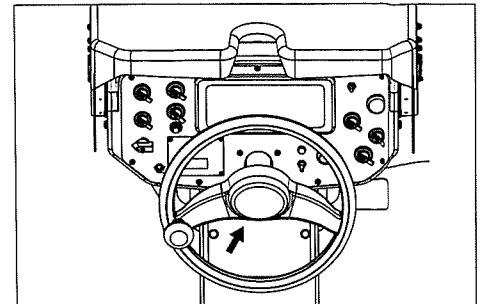

## 2. OPERATION

### Propel speed selector switch

Select mode according to propel condition.



position : Work condition

- The Auto speed function can be controlled with this mode. (See page 44)
- Maximum speed is regulated by each vibration frequency.

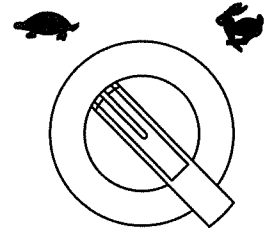



Vibration Frequency vpm	Propel speed mile / h (km / h)
2500	0 ~ 2.8 (0 ~ 4.5)
3000	0 ~ 3.4 (0 ~ 5.5)
4000	0 ~ 4.5 (0 ~ 7.2)



position : Traveling 0 ~ 6.8 mile / h (0 ~ 11 km / h)



- NOTE:
- Vehicle speed can be operated under at FULL position of Engine speed selector switch.  
Maximum speed is reference value.
  - Selection is applied only when the F-N-R lever is in the neutral position.

Vibration mode selector switch

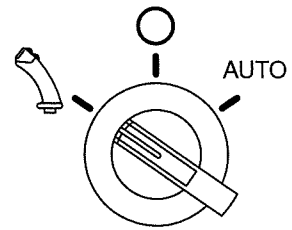
-  position : Vibration can be controlled by the vibration switch on the F-N-R lever
-  position : Vibration is shut off
- AUTO position : Vibration automatically engages when the F-R lever is moved into the forward or reverse



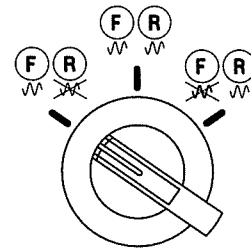

Vibration drum selector switch

-  position : Only the front drum will vibrate
-  position : Both drums will vibrate
-  position : Only the rear drum will vibrate



Vibration amplitude selector switch

-  position : Low amplitude vibration
-  position : High amplitude vibration

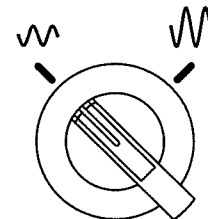

NOTE: Selection is applied only when the F-N-R lever is in the neutral position.

Vibration frequency selector switch

- 2500 position : Vibration can be set at 2500 vpm in the low or high amplitude position.
- 3000 position : Vibration can be set at 3000 vpm in the low or high amplitude position.
- 4000 position : Vibration can be set at 4000 vpm in the low amplitude position only. Vibration will automatically be limited to 3000 vpm when high amplitude is selected, regardless of the frequency selection. This machine can not operate at 4000 vpm in high amplitude.

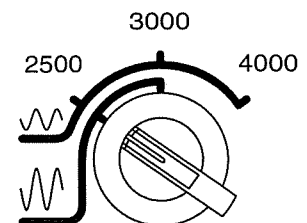

NOTE: Selection is applied only when the F-N-R lever is in the neutral position.

## 2. OPERATION

### Vibration switch

The vibration switch is integrated on the F-N-R lever. The green button toggles vibration “ on ” and “ off ”. When the green button is depressed the first time, vibration will turn on. When the green button is depressed a second time, vibration will shut off. The button must be depressed and held for one second in order to engage. It works only when “  ” is selected on the “ Vibration mode ” selector switch

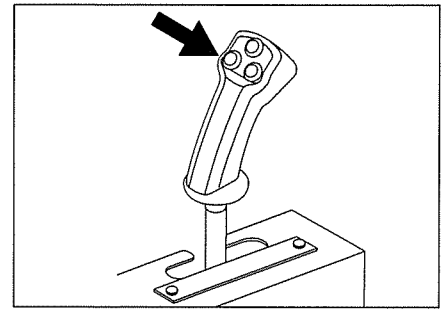

NOTE: For vibratory compaction, the “ Engine Speed ” selection switch must be in the FULL position.

The vibrator indicator lamp stays lit at all times when the machine is running in vibratory mode.

### IMPORTANT

- Do not operate the vibrator on a hard area such as cement concrete pavement surface or the ground covered by thick steel sheets.
- Turn the vibrator off when the machine is at rest.
- Shut off the vibrator immediately if the machine gets stuck in the mud during vibratory operation.

### IPF selector switch

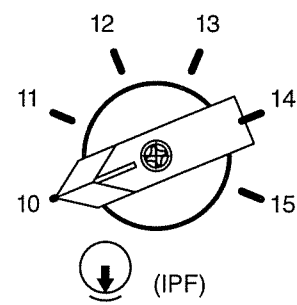

The Number of Impacts Per Foot (IPF) can be selected for when using the “ EXACT COMPACT METER ”.  
See 2.1.2 Exact Compact Operation Page 21  
IPF number can be set at 10, 11, 12, 13, 14, 15

NOTE: Selection is applied only when the F-N-R lever is in the neutral position.



Spray mode selector switch / Spray switch / Spray timer switch / Spray timer dial

Spray mode selector switch

-  position : Spray system can be controlled by the blue button switch on the F-N-R lever.
-  position : Spray system is shut off.
- AUTO position : Spray system is actuated when the F-N-R lever is in the forward or reverse position and deactivated when the F-N-R lever is moved to the Neutral position.

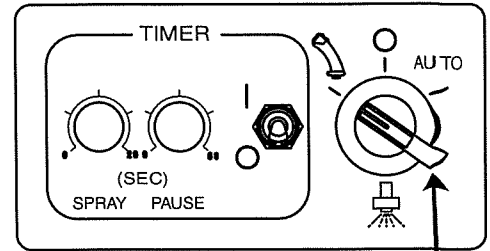



Spray mode selector switch

Spray switch

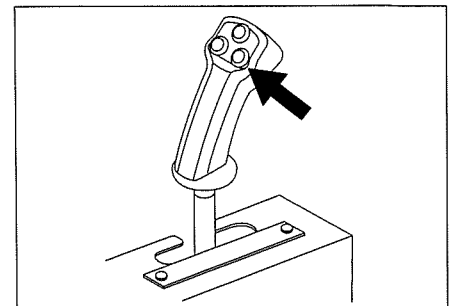
The spray sprinkler switch is integrated on the F-R lever. The blue button toggles the spray system on and off. Spray pumps will turn on when the blue button is depressed once and then turn off when the blue button is depressed a second time. Be sure to hold the button for at least one full second in order for it to engage. It works only when the " Spray mode selector switch " is set in the "  " position.



Spray timer switch

-  position : Spray timer is activated
-  position : Spray timer is shut off

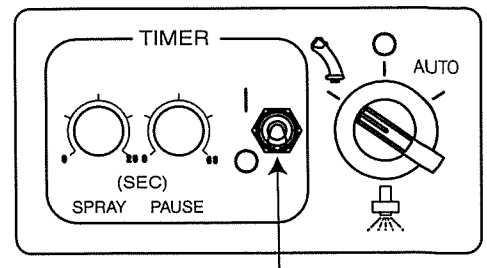

Spray timer switch

## 2. OPERATION

### Spray timer SPRAY dial

Spray time can be set from 0 ~ 20 seconds by turning this dial.

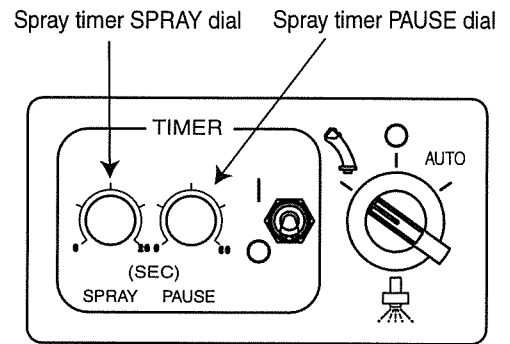

### Spray timer PAUSE dial

Sprinkling pause interval can be set from 0 ~ 60 seconds by turning this dial.

NOTE: The spray indicator lamp stays illuminated whenever water is spraying. In timer mode, the lamp will turn on (indicating spray) and off (indicating pause).

### Front spray pump selector switch

### Rear spray pump selector switch

There is a total of four spray bars on the SW Series rollers. Two spray bars on the front drum and two spray bars on the rear drum. Each spray bar has one water pump dedicated to it, for a total of four water pumps, one for each spray bar. When pump 1 is selected for either the front or rear drum, one spray bar is operational. When pump 2 is selected for either the front or rear drum, the second spray bar is operational. When "Both" is selected for either the front or rear drum, both spray bars operate, providing double the volume of water going to wet the drum. In most cases, only pump 1 or pump 2 is selected. In a few situations, where a heavy application of water is required on the drum, such as in very windy and/or dry desert conditions, both pumps are used simultaneously.

When only one pump is required, it is recommended to alternate pumps so that they both wear evenly. Alternating pump use also helps to keep them in better operating condition by running water through them to keep the inside of the pump wet. For example, on a multi-day project, it is recommended to use pump 1 on the first day, pump 2 on the second day, and alternate each day.

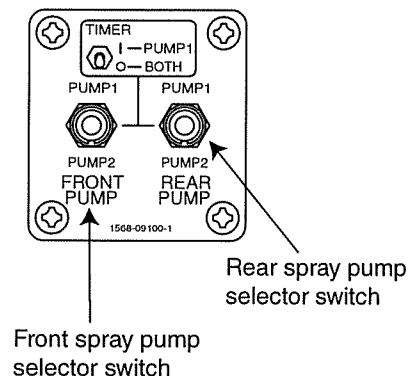

PUMP1 position : Actuate #1 pump

Center position : #1 pump when deselect intermittent spray (see4)

#1 & #2 pumps when select intermittent spray (see4)

PUMP2 position : Actuate #2 pump



Engine diagnostic switch

Activates the diagnosis function of engine control unit. Turn the switch lever to the “ I ” position and hold for at least two seconds. After releasing the switch lever, the existing faults are read out as blonk code via Engine check lamp.

See.2.3.4 Engine diagnoses Page 39 for detail.



Emergency propel switch

Propel the vehicle with this switch if the vehicle can't be propelled with F-N-R lever.

Sometimes called a “ limp home ” switch, this function will only work after MANUALLY plugging in the appropriate wire harness connection.

See 2.3.5 Traveling Page 42 for the detailed procedure on how to plug in the wire harness.



AUTO SPEED set switch

The AUTO SPEED set switch is the top button on the F-N-R lever.

The speed that the roller is traveling at when the button is depressed will be recorded into memory. The Button must be depressed and held for at least one second.

When auto speed is set, the machine will run at the preset speed when the F-N-R lever is moved to the full forward or full reverse position.

The auto speed memory is cancelled when the button is pushed a second time and held for one second or longer.

See 2.3.7 AUTO SPEED Page 44 for full operational instructions.

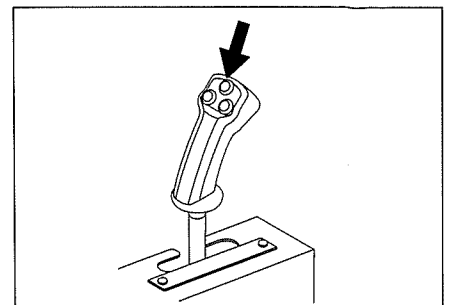

## 2. OPERATION

### 2.1.4 Operating Levers / pedals

#### Forward-Neutral-Reverses lever (F-N-R lever) with AUTO SPEED / Vibration / Spray switch

Moving the F-N-R lever forward or backward makes the machine travel forward or backward respectively. The neutral position brings the machine to a stop. The vehicle speed increases or decreases in proportion to the lever displacement. AUTO SPEED / Vibration / Spray switches are integrated on this lever.

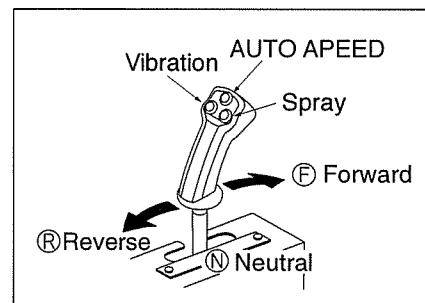

#### IMPORTANT

**In an emergency, depress the brake pedal or press the parking brake button.**

#### Brake pedal

In an emergency, press the brake pedal to the full extent, then the vehicle will stop suddenly together with its engine.

NOTE: The F-N-R lever must be in the neutral position to release the brake for the travel again.

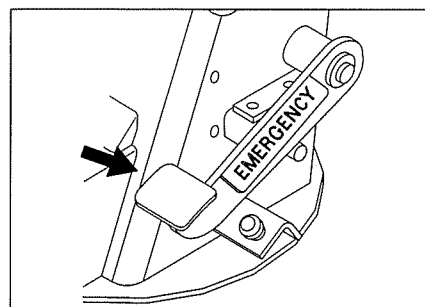

#### IMPORTANT

**Do not use the brake pedal for normal machine operation. Use only in an emergency. Use the F-N-R lever to stop the machine under normal operating conditions. Continuous use of the emergency brake pedal will damage the brake.**

### Unloader valve

The unloader valve disengages the drive, similar to a clutch. Use this valve for towing the machine when the engine is disabled or when trouble has developed in the hydraulic drive.

For towing:

Turn the lock knob counter – clockwise, then turn the hand knob counter - clockwise fully. It is now in the UNLOAD position.

For normal traveling:

Make sure the lock knob is turned counter - clockwise fully, then turn the hand knob clockwise fully, then turn the lock knob clockwise to lock the handle. It is now in the ONLOAD position.

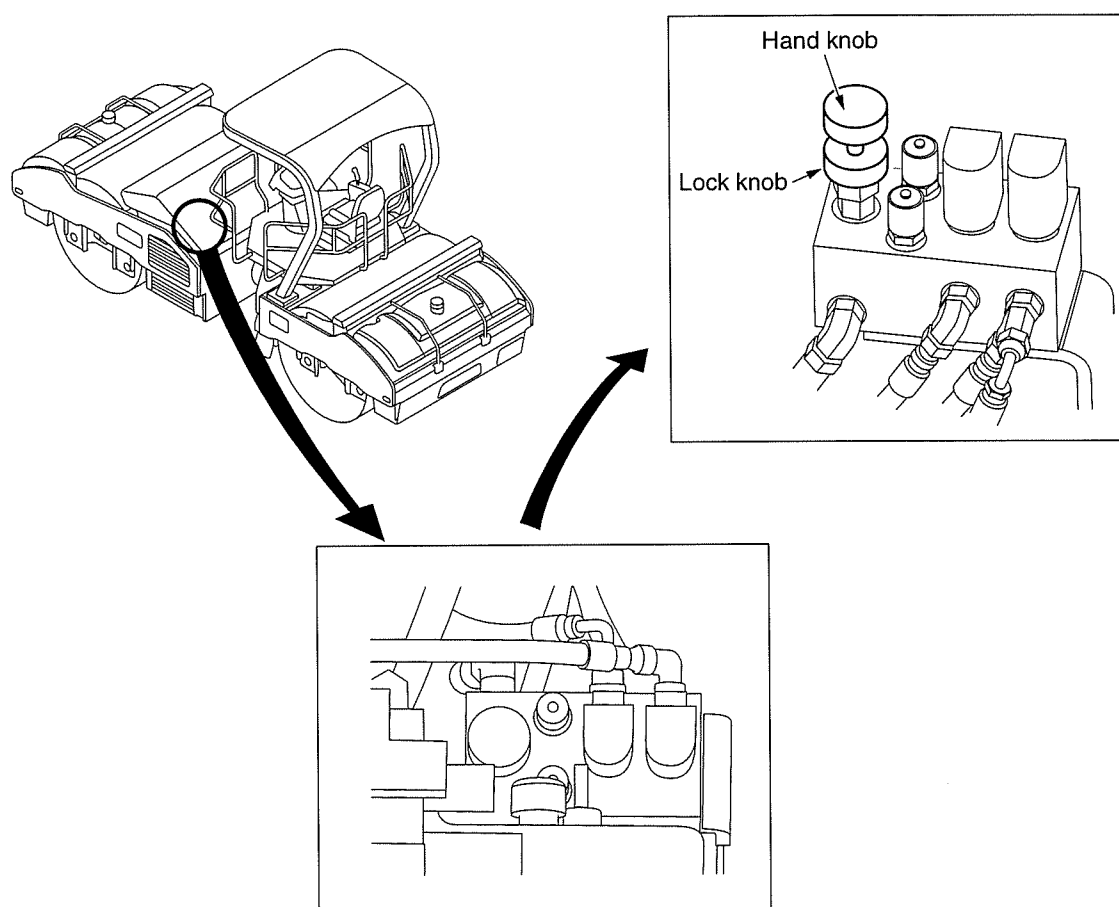

### ⚠ WARNING

- On a slope, chock the wheels and use extreme care when using the unloader valve and towing the machine.
- Be sure to apply the parking brake when operating the unloader valve.

NOTE: For normal travel, be sure that the unloader valve is in the ONLOAD position.

## 2. OPERATION

### 2.1.5 Fuse box and line fuse

#### **⚠ WARNING**

When changing a fuse, cut the power supply by turning the starter switch to the OFF position.

Fuses protect electrical components and wiring from burning. Change any fuse which has become powder-coated due to deterioration or which has play between it and fuse holder. To replace fuses, take off the cover. Be sure to use fuses of correct capacity.

Using improperly rated fuses may result in poor machine performance, damage to the electrical system, or safety problems, such as an electrical fire.

See page 88 for location.

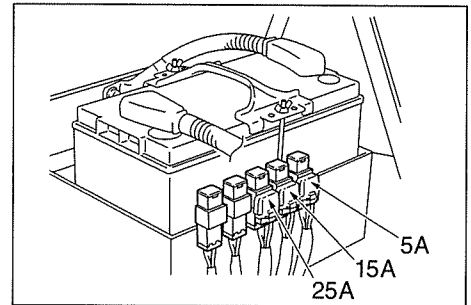
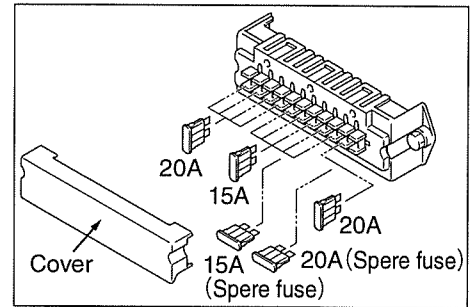

## 2.2 Handling and Adjustments

### 2.2.1 Seat adjustment

Adjust the seat for your best operating position. Move the lever as shown by arrow. With the lever held in that position, slide the seat forward or backward as desired. When properly adjusted, release the lever.

Adjust your seat position to suit you as follows:

- 1) Pull the lever ① and adjust seat position longitudinally.
- 2) Turn the backrest adjust pull the lever ② for optimum angle.
- 3) Move the suspension lever ③ to select suitable suspension for your body weight.

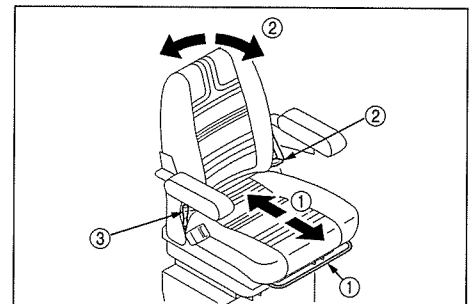

#### **⚠ WARNING**

The adjustment will be necessary when operating the machine first or when operators are alternated.

#### **IMPORTANT**

Be sure to wear the seatbelt during operation.

### 2.2.2 Scraper adjustment and replacement

#### Scraper

Adjusting the gap between scraper blade (a) and drum.

- 1) Loosen lock nuts (b) at 2 locations and nuts (c) at 7 locations.
- 2) Adjust scraper blade (a) to eliminate the clearance between scraper blade (a) and drum.
- 3) Tighten nuts (c).
- 4) Make fine adjustment of the gap between scraper blade (a) and drum by set bolt (d).
- 5) Tighten lock nuts (b).

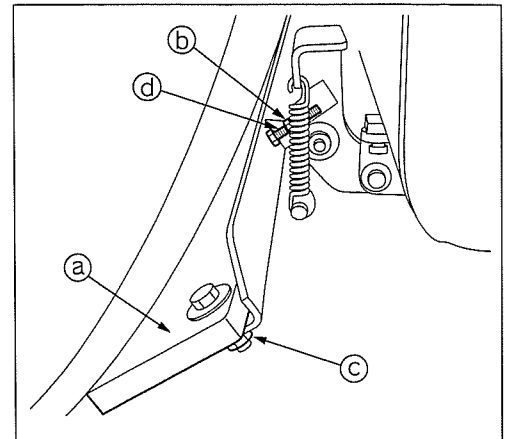
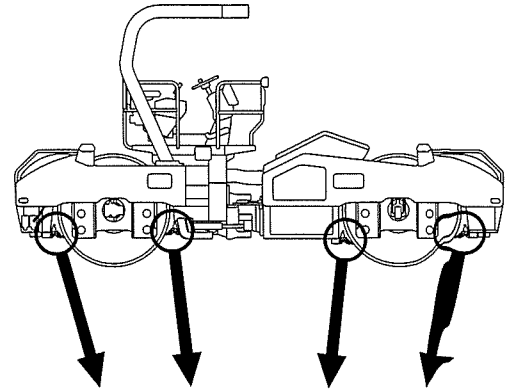

Replacing the scraper blade.

- 1) Remove bolts and nuts (c) at 7 locations.
- 2) Replace scraper blade (a) with new one.
- 3) Reinstall and tighten the bolts and nuts (c).

## 2. OPERATION

### 2.2.3 Disengaging the brake when towing

#### ⚠ WARNING

On a slope, chock the drums and prepare for towing before disengaging the brake.

For towing the machine when the engine is disabled or when trouble has developed in the hydraulic propulsion system, disengage the brake as instructed below:

Use the same procedure for both front and rear drums.

- 1) Remove the brake-disengaging bolts and washers (two each) from the machine frame.

Brake-disengaging bolts and washers (red)

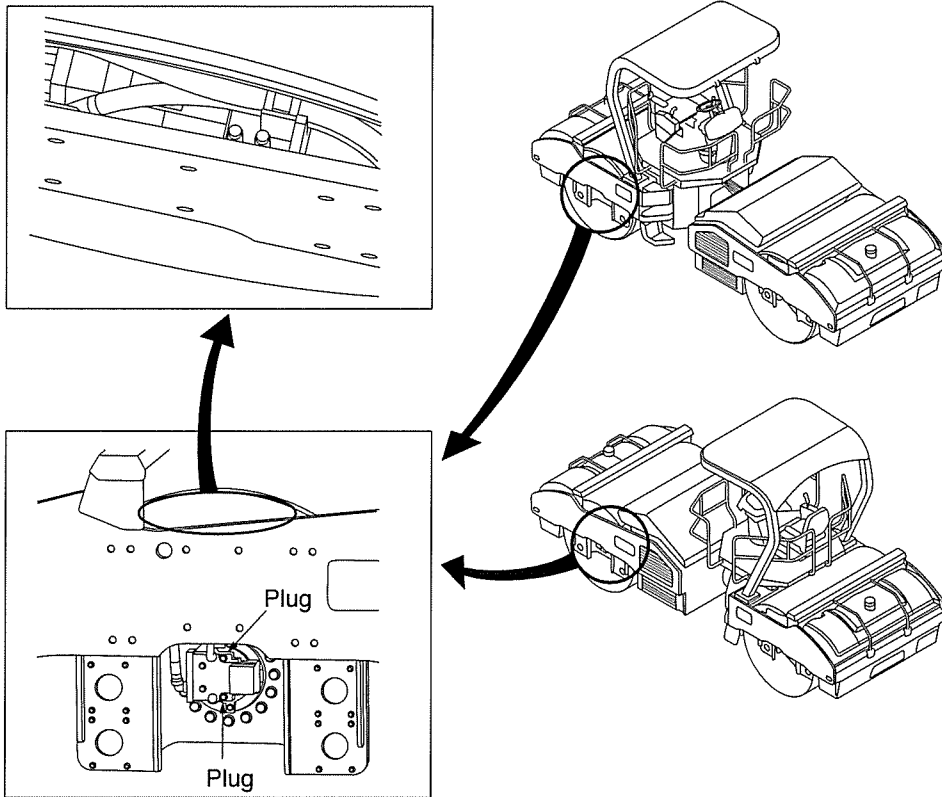

#### ⚠ WARNING

- Do not try to release the brake immediately after a hot engine has been stopped. Let the oil cool down.
- For the brake disengagement, wear hard hat and safety goggles and protector glove.

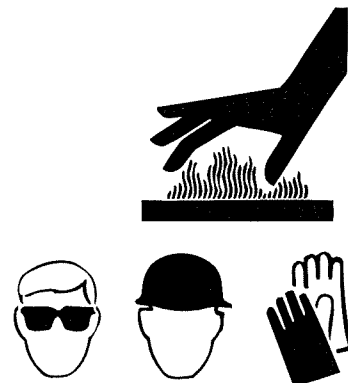

- 2) Remove the plugs (2 locations) from the motor.

NOTE: Conduct the work rapidly, as the oil will gush out when the plugs are taken off.

- 3) Screw in the removed bolts with the washers into the plug holes. Screwing in them until they become a little tight will disengage the brake.

NOTE: Wash clean the brake release bolts and blank plugs before fitting to the motors.

- 4) After towing, replace the bolt and washer to original position and tighten the plug securely to the motor.

### 2.2.4 Steering wheel position adjustment

- 1) Pull the lever (a) upward. Doing so disengages the lock off the wheel.
- 2) Position the wheel for your operating comfort.
- 3) Lower the lever (a) to lock the wheel in place.

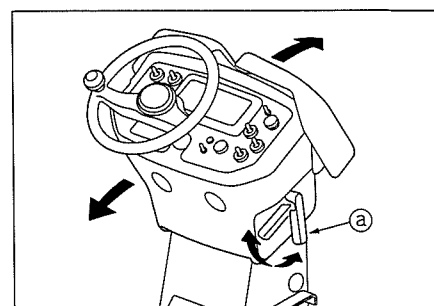

### 2.2.5 Operator's platform position adjustment

Operator's platform rotates by 60 and 90 degrees, clockwise or counterclock – wise.

Set it at the desired angle to allow you to easily see the drum edge during work.

- 1) While depressing the swivel pedal (b), rotate the operator's platform by pushing or pulling with your other foot.
- 2) As soon as it starts rotating, release the swivel pedal (b) and continue to push the operator's platform at 60 degrees, it will automatically lock into position.
- 3) Continuing the same action while depressing the swivel lever (b) will allow the operator's platform to lock automatically at 90 degrees.

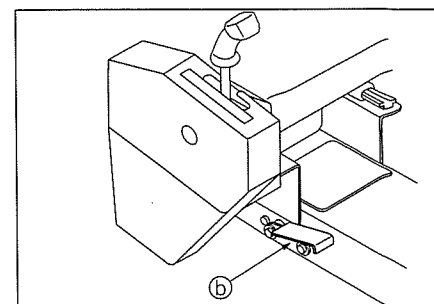

### ⚠ CAUTION

**Sit down on the seat during this operation for your safety.**

Make sure the operator's platform is completely locked in place before continuing to operate the machine. If the operator's platform is not locked in place, it could unexpectedly rotate during operation and cause the operator to lose control of the machine and result in an accident with the potential for injury or death.

## 2. OPERATION

### 2.3 Operation

#### ⚠ WARNING

- This machine is a one-man roller.
- Operate the machine from the operator's seat with seatbelt properly fastened.

#### 2.3.1 Before-starting inspection

- 1) Check that the steering lock bar is in the carrying position.

#### ⚠ WARNING

Make sure that the steering lock bar is connected in the carrying position before putting the machine in motion. Steering is impossible if the bar is in the steering lock position.

The bar is located at the right of the center of the machine.

To unlock the bar

- ① Remove the spring pin.
  - ② Pull out the lock pin.
  - ③ Set the bar in the carrying position.
  - ④ Retain the lock bar in the locked position by inserting the lock pin into the lock holes.
  - ⑤ Secure the lock pin with the spring pin.
- 2) Check that the F-N-R lever is in the neutral position (N) .

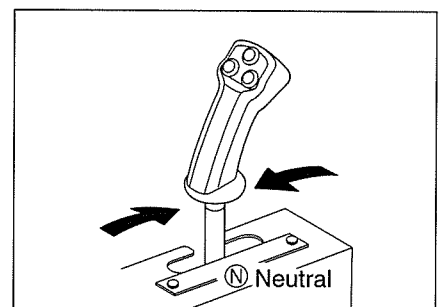
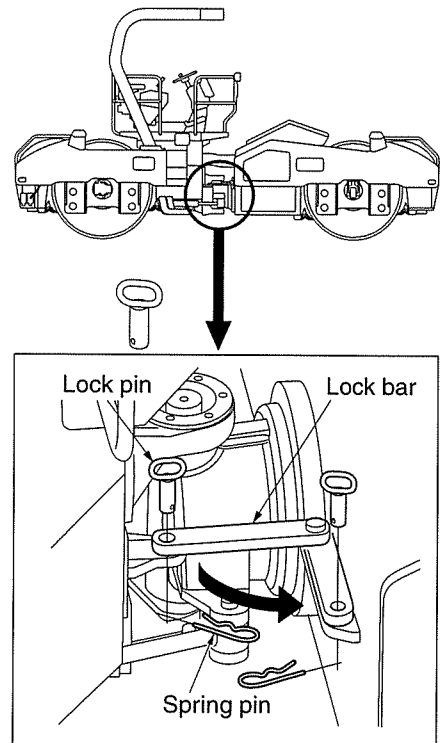

- 3) Check the parking brake switch is applied.

NOTE: Set the forward reverse (F-R) lever in the neutral position and press down the parking brake switch before starting the engine. Unless these conditions are met, the ENGINE will not start.

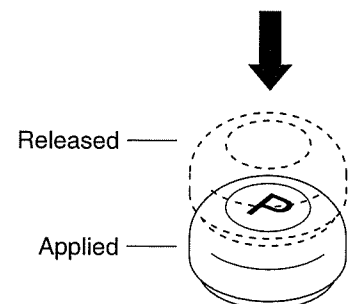



## 2.3.2 Starting the engine

**⚠ WARNING**

- Check that there are no people or obstacles around the vehicle and beep the horn before starting the engine.
- Set the Forward-Neutral-Reverse (F-N-R) lever in the neutral position and press down the parking brake switch before starting the engine.  
Unless these conditions are met, the ENGINE will not start.

1) Select IDLE position of Engine speed selector switch.

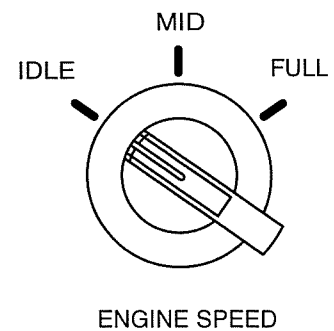

2) Turn the starter switch to the ON position and check that the warning lamps and parking brake indicator lamp on the monitor display are on.

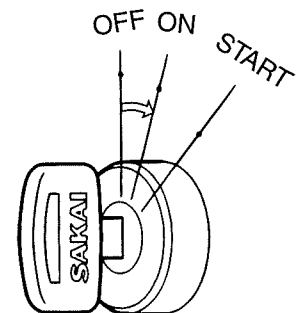
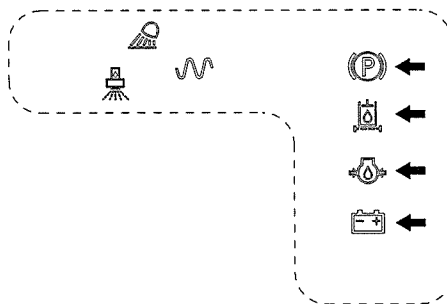

Also the “ Engine Check ” lamp lights up for approx. 2 sec. and goes out.

ENGINE  
CHECK



## 2. OPERATION

- 3) Turning the key to the START position to start the engine. Release the key the moment the engine has started. The key will automatically return to the ON position.

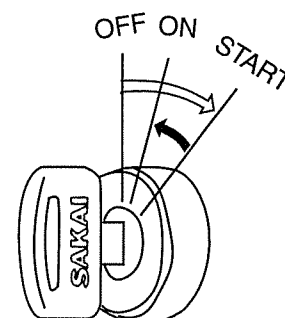

### ⚠ CAUTION

- Do not allow the starter key to stay in the START position for more than 15 seconds.
- If the engine does not start, wait until the Engine Check lamp goes out before attempting to re-start the engine.
- Check that the warning lamps on the monitor display go off immediately after the engine is started. If any of these warning lamps stay on while the engine is running, shut down the machine, determine the cause and rectify the fault.

### 2.3.3 After starting the engine

Try not to move the machine immediately after starting but practice the following:

### IMPORTANT

**Avoid increasing the engine speed abruptly before warming-up run is completed.**

- 1) Run the engine IDLE position of Engine speed selector switch for about 5 minutes to warm it up. Warming-up run allows the lubricating oil to reach the vital parts of the engine and hydraulic system, while gradually bringing up the engine oil and hydraulic oil to the working temperature.
- 2) After the warm-up operation, check that:
  - Temperature gauge .....Pointer falls near the center zone
  - Fuel gauge .....Pointer falls between the E and F marks
  - Charge lamp .....Has gone off
  - Engine oil pressure warning lamp.....Has gone off
  - Engine check lamp.....Has gone off
- 3) Check for the color of exhaust gas, listen for unusual sounds and vibration. If abnormal, determine the cause and correct the problem.

### 2.3.4 Engine diagnoses

If ENGINE CHECK lamp stays illuminated or is flashing rapidly, an engine error has been detected. Error codes can be read out according to the procedure below.

With the DIAGNOSTIC switch ①, it is possible to read the existing faults as blink codes. The DIAGNOSTIC switch ① and ENGINE CHECK lamp ② are on the instruments panel.

Faults are indicated by a blinking or steady lighting of the ENGINE CHECK lamp ②.

More detailed information regarding all faults can be read out in the form of a blink code, only when the engine is not running, in the following manner.

After actuating the DIAGNOSTIC switch ① for at least two second, the ENGINE CHECK lamp ② goes out and the first fault is output after releasing the DIAGNOSTIC switch ① as a blink code. Evaluate blink code as per the table on the engine manual. After outputting the fault blink code, ENGINE CHECK lamp ② goes out for five seconds.

Then the next existing fault (i.e. the following one in the fault memory) can be shown by actuating the DIAGNOSTIC switch ① again. After the last existing fault is shown, by actuating the DIAGNOSTIC switch ① the first fault will be shown again.

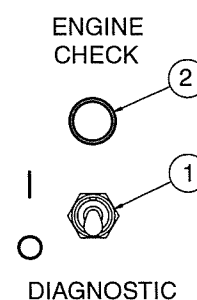

#### Examples

Blink code	Function / Component	Service
1-3-6	Monitoring air filter	Clean or replace element
2-2-8	Monitoring fuel filter water level	Drain water
2-3-5	Monitoring coolant state	Add coolant necessary

The blink code values in the first column indicate the number of preliminary short blink signals (illuminated duration approx. 0.4 s), the number of subsequent long blink signals (illuminated duration approx. 0.8 s), as well as the number of concluding short blink signals.

The code 1-3-6 for the fault "Monitoring air filter" is made up of one short, three long and six short blink signals, for example.

Other possible blink codes, their meaning and measures for correcting faults can be found in the table in the engine manual.

#### IMPORTANT

**When the engine malfunctions or fails, contact your SAKAI Dealer immediately for appropriate inspection, maintenance, or repair.**

## 2. OPERATION

### 2.3.5 Traveling

#### ⚠ CAUTION

While travelling, do not turn the ignition key OFF.

#### ⚠ WARNING

- When starting, operate the horn after securing the safety around the machine.
- Be sure to wear the seatbelt during operation.

1) Select mode according to propel condition.

 position : Work condition

- The AUTO SPEED function can be controlled with this mode. (See page 44)
- Maximum speed is regulated by each vibration frequency.

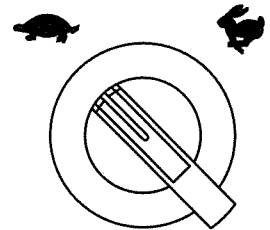

Vibration Frequency vpm	Propel speed mile / h (km / h)
2500	0 ~ 2.8 (0 ~ 4.5)
3000	0 ~ 3.4 (0 ~ 5.5)
4000	0 ~ 4.5 (0 ~ 7.2)

At FULL position of Engine speed selector switch.

 position : Traveling condition 0 ~ 6.8 mile / h (0 ~ 11 km / h).

NOTE: Selection is applied only when the F-N-R lever is in the neutral position.

2) Select MID or FULL position of Engine speed selector switch.

NOTE: Vehicle speed can be operated under at FULL position of Engine speed selector switch. Maximum speed is reference value.

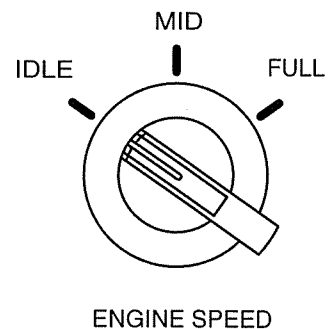

- 3) Press down the parking brake switch button to release the brake. Check that indicator lamp (P) on the monitor display goes off.

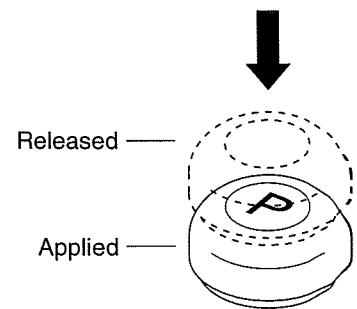

- 4) Move the F-N-R lever in the direction to travel, and the machine will begin traveling.

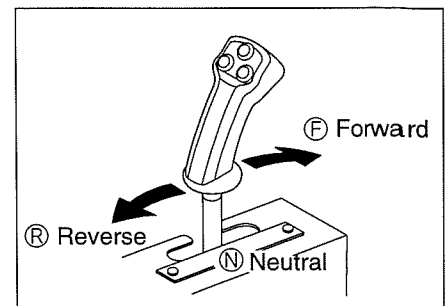

NOTE: The travel speed can be controlled by the F-N-R lever and the Engine speed selector switch.

### ⚠ CAUTION

Avoid abrupt operation of the F-N-R lever.

### ⚠ WARNING

- Pay extreme attention to the area behind the machine when backing, since the space immediately behind tends to be a blind spot.
- Pay careful attention to your surroundings and maintain control of the machine when changing switch positions. Whenever possible, stop the machine to change switch settings before continuing operation.

## 2. OPERATION

### Emergency traveling

If the vehicle doesn't move when you operate the forward and reverse control lever while the engine is running, there maybe a problem with the control system.

In this case, you may bypass the controller to temporarily drive the vehicle by following the procedure below.

- 1) Push on the parking brake. Shut off the engine and make sure the emergency propel switch is in the neutral position.

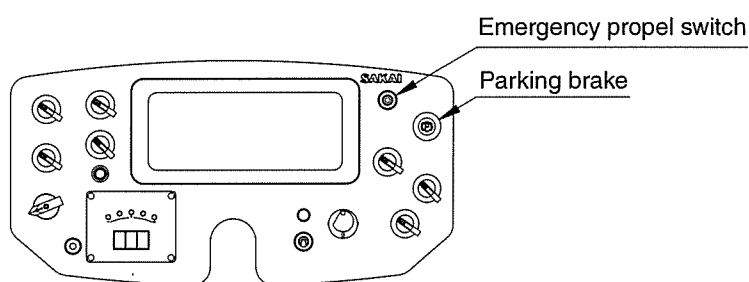

- 2) Identify the connectors " PRO " & " EME " between the valve blocks on the left side of the machine.

- 3) Remove the plugs from connector " PRO " then exchange connectors " PRO " and " EME ".

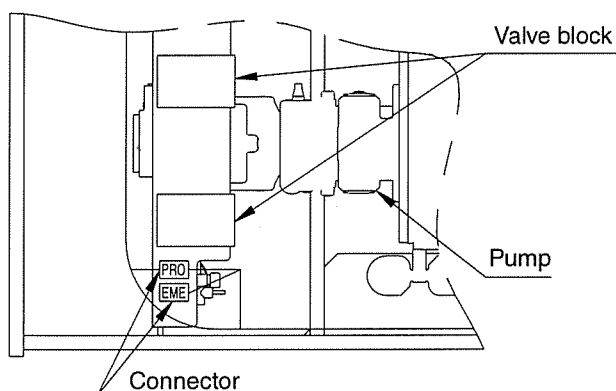

- 4) Make sure the connectors are properly connected, close the hood but do not start the engine until you have checked the surrounding area for obstacles. Also make sure that the emergency switch and traveling direction of the vehicle are the same. Now it will be safe to move the machine to a safe area.

If the vehicle will not move at this point there are other problems. You will have to tow the vehicle to safe area.

When you exchange connectors again, follow the procedure below.

- Push on the parking brake.
- Shut off the engine.
- Be sure the F-N-R over ride switch is in neutral.
- Contact your servicing dealer.

### IMPORTANT

Contact your Sakai Dealer to service the vehicle, after the vehicle is transported to a safe place.

### 2.3.6 Stopping and parking

#### ⚠ WARNING

- Avoid abrupt braking. Leave enough space for braking safely.
- Avoid parking on a grade.
- If necessary to park on a grade, block the drums to prevent unexpected moving down the grade.

- 1) Move the F-N-R lever to the neutral position (N), and the vehicle will stop.

#### ⚠ CAUTION

For normal braking, move the F-R lever to the neutral position. In an emergency, depress the brake pedal.

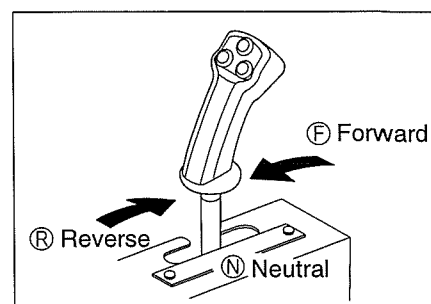

#### IMPORTANT

After depressing the brake pedal, return the F-R lever to the neutral position, otherwise the vehicle will not start.

- 2) Press the parking switch button securely, and check that indicator lamp (P) illuminates.

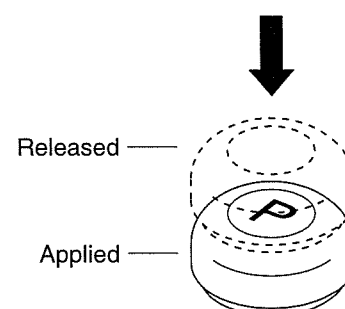

## 2. OPERATION

### 2.3.7 AUTO SPEED

#### 2.3.7.1 Setting

The vehicle propel speed can be memorized by the vehicle controller and the speed is controlled automatically. It will help to easily control your speed to a preset value when a certain speed is required on the work site.

NOTE: The AUTO SPEED function only operates when the Engine Speed selection switch is set to FULL and the Propel speed selection is in the “” position.

NOTE: The minimum allowable AUTO SPEED setting is 1.5 miles per hour.

- 1) With the machine in moving at the desired AUTO SPEED setting, press the TOP button on the F-N-R lever and hold for at least one second to set the AUTO SPEED equal to the current machine speed.

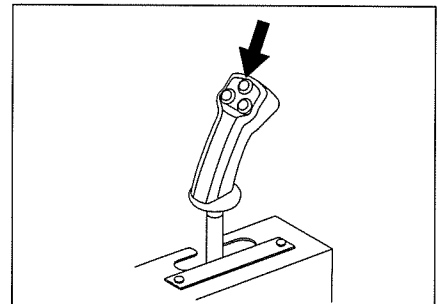

- 2) Check the AUTO SPEED lamp  
If the AUTO SPEED is successfully set up in Step 1, the AUTO SPEED lamp will remain lit. If the lamp is not illuminated, repeat Step 1.



AUTO SPEED

- 3) After setting the AUTO SPEED in Step 1, move the F-N-R lever to the neutral position (N).  
The AUTO SPEED feature is now set so that the machine will travel at the preset speed when the F-N-R lever is in the full forward or full reverse position.

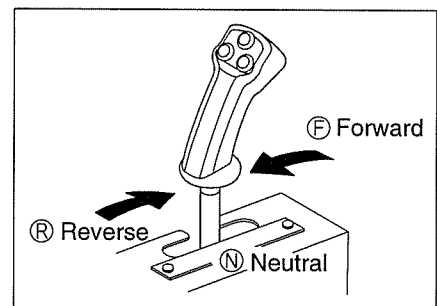

#### CAUTION

**Do not change the IPF / Vibration Frequency / Vibration Amplitude / Propel Speed / Engine Speed switch setting after setting the AUTO SPEED without first canceling the AUTO SPEED. Doing this will cause the AUTO SPEED lamp flicker until the IPF / Vibration Frequency / Vibration Amplitude / Propel Speed / Engine Speed switch is set back to the position it was in when AUTO SPEED was set.**



### 2.3.7.2 Canceling AUTO SPEED

- 1) Press and hold the Top button on the F-N-R lever for at least one second when the AUTO SPEED lamp is lighted on.
- 2) Check the AUTO SPEED lamp.  
It is ready to cancel the AUTO SPEED, the lamp will flicker. If the lamp is not flickering, press the Top button again and hold for at least one second.
- 3) Move back the F-N-R lever to neutral position (N).  
AUTO SPEED is cancelled after the machine stops.
- 4) Check the AUTO SPEED lamp.  
When the AUTO SPEED is cancelled completely, the lamp goes off.

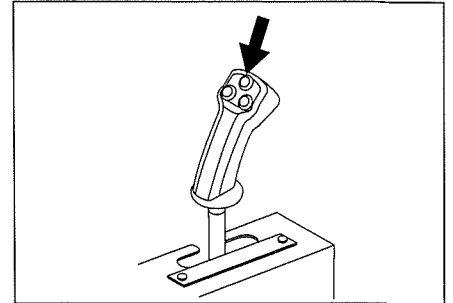

AUTO SPEED

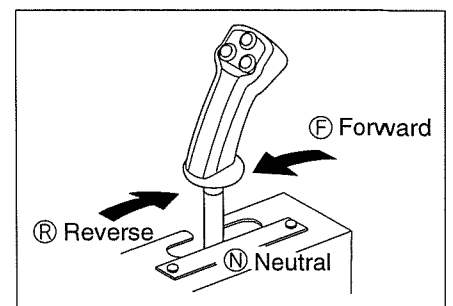

#### ⚠ CAUTION

Move the F-N-R lever slowly at first after the AUTO SPEED feature has been canceled because the vehicle response will be faster now.

## 2. OPERATION

### 2.3.8 Stopping the engine

- 1) Gradually cool down the engine by running at low idle for about 5 minutes.

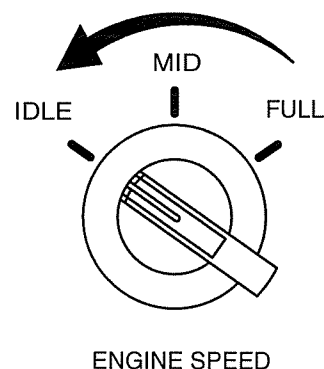

#### IMPORTANT

- Do not bring a hot engine to a sudden stop except for an emergency. This will shorten the life of its component parts.
- Do not allow an overheated engine to come to a sudden stop, but run it at middle idling speed for gradual cooling down before shutting off.

- 2) Turn the ignition key to the OFF position to stop the engine.

#### CAUTION

Do not turn the starter switch OFF while the machine is in motion.

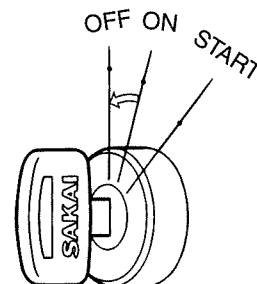

- 3) Remove the ignition key.

#### WARNING

- When dismantling from the machine, apply the brake by pressing the parking brake switch. If necessary to park on a grade, block the wheels to prevent unexpected moving down the grade.
- Never fail to remove the starter key

### 2.3.9 Check after stopping the engine

- 1) Perform the walk-around checks for oil and water leakage, abnormal signs around the drums.
- 2) Fill the fuel tank.
- 3) Remove waste paper if any from the engine compartment, as this will pose a possible fire hazard.
- 4) Scrape mud or other materials from and around the drums

## 2.4 Vibratory Operation

- 1) Select FULL position of Engine speed selector switch.  
Appropriate vibration force is engaged when the Engine Speed selector is in the FULL position.

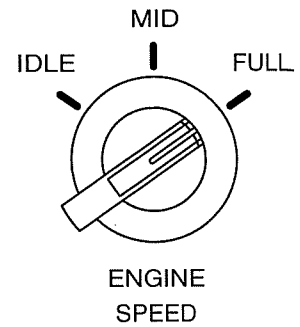



- 2) Select  or AUTO position of Vibration mode selector switch.

 position : Vibration can be controlled by the vibration switch on the F-N-R lever

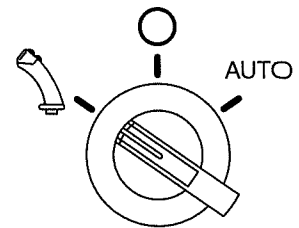
AUTO position : Vibration is automatically engaged when the F-N-R lever is moved into the forward or reverse positions



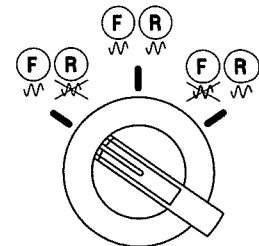

- 3) Select Vibration drum of Vibration drum selector switch.

-  position : Only the front drum will vibrate
-  position : Both drums will vibrate
-  position : Only the rear drum will vibrate



- 4) Select Vibration amplitude

-  position : Low amplitude vibration
-  position : High amplitude vibration

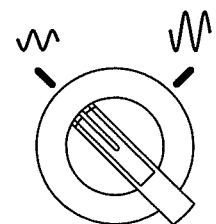

NOTE: Selection is applied only when the F-N-R lever is in the neutral position.

## 2. OPERATION

### 5) Select Vibration frequency.

2500 position : Vibration can be generated at 2500 vpm at low or high amplitude.

3000 position : Vibration can be generated at 3000 vpm at low or high amplitude.

4000 position : Vibration can be generated at 4000 vpm only in the low amplitude setting.

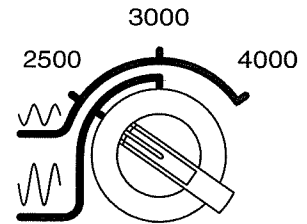

NOTE:

- If 4000vpm is selected and the machine is set on the high amplitude, it will default to operating in high amplitude at a frequency of 3000 vpm.
- Selection is applied only when the F-N-R lever is in the neutral position.

### 6) Select Impacts per Foot using the IPF selector switch.

Number of Impacts Per Foot is selected as an input value for the " EXACT COMPACT METER ".

See 2.6 Exact Compact Operation page 52

IPF number can be selected from 10, 11, 12, 13, 14, 15

The green lights on the EXACT COMPACT METER will light up when the vehicle speed matches the desired IPF number.

See 2.6 Exact Compact Operation page 52 for more details.

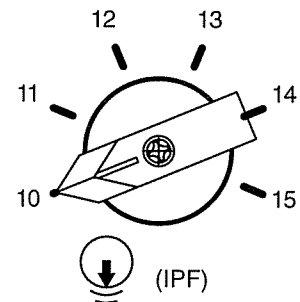

NOTE: Selection is applied only when the F-N-R lever is in the neutral position.

### 7) To generate vibration.

When the AUTO mode is enabled as described in Step 2 above, placing the F-N-R lever in the Forward or Reverse positions will cause the vibration to engage automatically when the machine starts in motion.

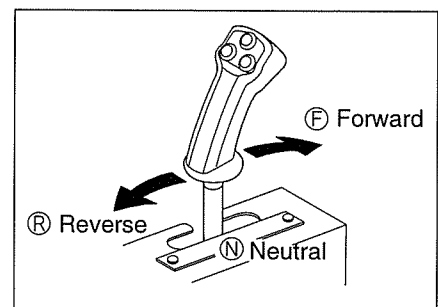

NOTE: Vibration can not be controlled by the vibration switch on the F-N-R lever in Auto speed mode.

When  position is selected in Step 2, press and hold the vibration switch (green button) for at least one second to start vibration. The vibration indicator lamp on the F-N-R lever will illuminate.

To shut off vibration, press and hold the green button on the F-N-R lever for at least one second. The vibration indicator lamp will shut off when no vibration is occurring.

**⚠ CAUTION**

- Keep the vibrator shut off when the machine is not rolling.
- Shut off the vibrator immediately if the machine becomes stuck in soil during vibratory operation.

**⚠ WARNING**

Pay careful attention to your surroundings and maintain control of the machine when changing switch positions. Whenever possible, stop the machine to change switch settings before continuing operation.

## 2.5 Water Spray System

- 1) Before turning the spray system on, check level in the water tank with the sight gauge. Add water as necessary.

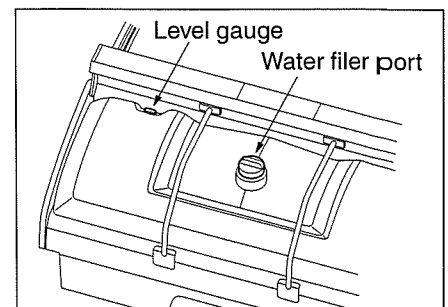

**IMPORTANT**

Use clean water wherever practicable.

- 2) Select  or AUTO position of Spray mode selector switch.



position : Spray system can be controlled by the blue button switch on the F-N-R lever



position : Spray system is shut off

AUTO position : Spray system is actuated when the F-N-R lever is in the forward or reverse position and deactivated when the F-N-R lever is moved to the Neutral position

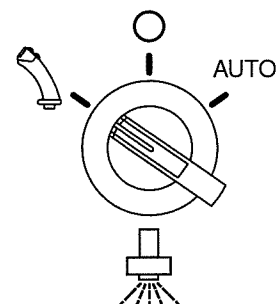

- 3) Select water pumps for front and rear drums.

Two each of same water pumps are installed to front drum and rear drum spray system. There are three positions at each switch.

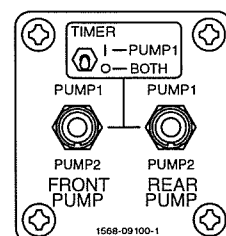

PUMP1 position : Actuate #1 pump

Center position : #1 pump when deselect intermittent spray (see4)  
#1 & #2 pumps when select intermittent spray (see4)

PUMP2 position : Actuate #2 pump

## 2. OPERATION

4) Select I position of timer switch for intermittent spray.

- I position : Spray timer is activated
- O position : Spray timer is shut off

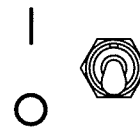

5) Adjust spray time and pause time.

Spray time is adjustable between 0 ~ 20 seconds using the SPRAY Dial and pause time is adjustable between 0 ~ 60 seconds with PAUSE Dial as desired. Adjust according to the job site conditions.

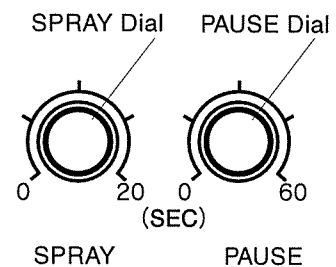

6) To start spraying.

When AUTO position is selected, placing the F-N-R lever in the Forward or Reverse position causes travel and sprinkling to start simultaneously.

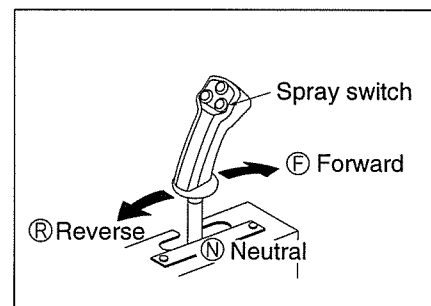

NOTE: The water can not be controlled by the spray switch.

When  position is selected, press the blue button and hold for at least one second and the system will start spraying. The spray lamp will illuminate.

Pressing and holding the blue button for at least one second while the system is spraying will cause the sprinkling to stop.

The spray indicator lamp will turn off.

### IMPORTANT

When starting asphalt compaction, place the spray switch in the  position and moisten the drum surface completely before selecting TIMER spray. For resuming work after a short break, follow the same procedure.

### WARNING

Pay careful attention to your surroundings and maintain control of the machine when changing switch positions. Whenever possible, stop the machine to change switch settings before continuing operation.

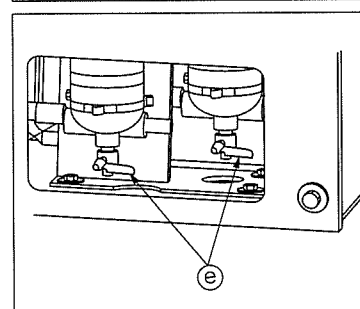
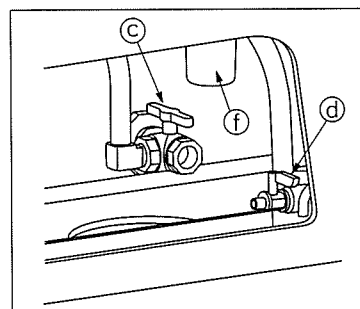
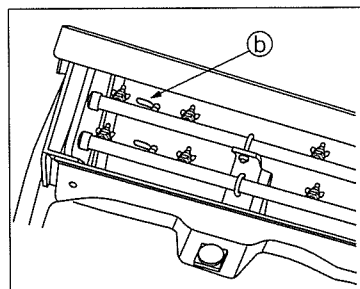
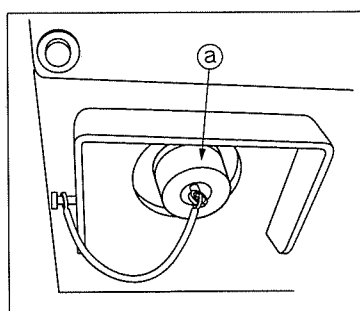

Spray bars and drain cocks

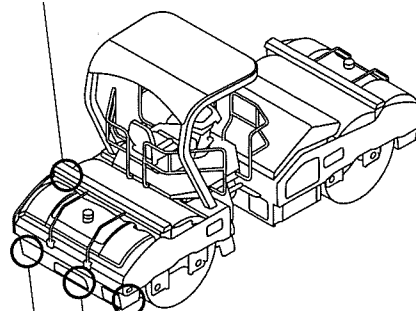
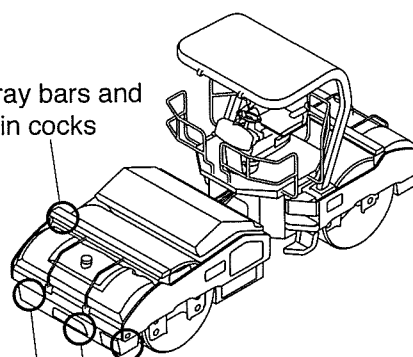
Water pump drain cocks  
Water filter / water tank selector valve  
Water tank drain hole capSpray bars and  
drain cocksWater pump drain cocks  
Water filter / water tank selector valve  
Water tank drain hole cap**To drain water**

- 1) Take off the drain caps (a) of water tanks and drain water from the tanks completely.
- 2) Open drain cocks (b) of spray bars at front and rear, to drain water completely.
- 3) Turn the lever of water tank selector valve (c) counterclockwise, open the drain cocks (d) of water filters and open the drain cocks (e) of water pumps.  
Take off the bowl (f) from water filters then throw away water in the bowl then put the bowl back on the water filters.
- 4) Run the water pumps approximately 30 seconds with the drain cocks open.
- 5) Make sure water is completely drained from all hoses, water pumps and spray nozzles.

**⚠ CAUTION**

- To avoid freezing, fully drain the water tank, pipes and filters in cold weather.
- Pay attention to the water level because turning the pump with an empty water tank will damage the pumps.

## 2. OPERATION

### 2.6 EXACT COMPACT Operation (Impact Space Indicator & Speed Meter)

#### 2.6.1 Function

- 1) Indicates if the roller is achieving the desired number of impacts per foot based on the inputs of rolling speed and the operating frequency of the roller. The information is visually displayed by yellow, green, and red LED lights.
- 2) Indicates the rolling speed.
- 3) Indicates the error codes of the vehicle controller.
- 4) Indicates the rolling surface temperature. (OPTION)

#### 2.6.2 Operating instruction

##### IPF selector switch

The desired number of Impacts Per Foot can be selected as an input for the EXACT COMPACT METER.

IPF number can be selected from 10, 11, 12, 13, 14, 15.

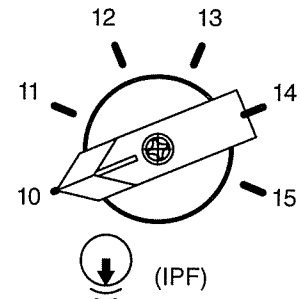

NOTE: Selection is applied only when the F-N-R lever is in the neutral position.

##### Display

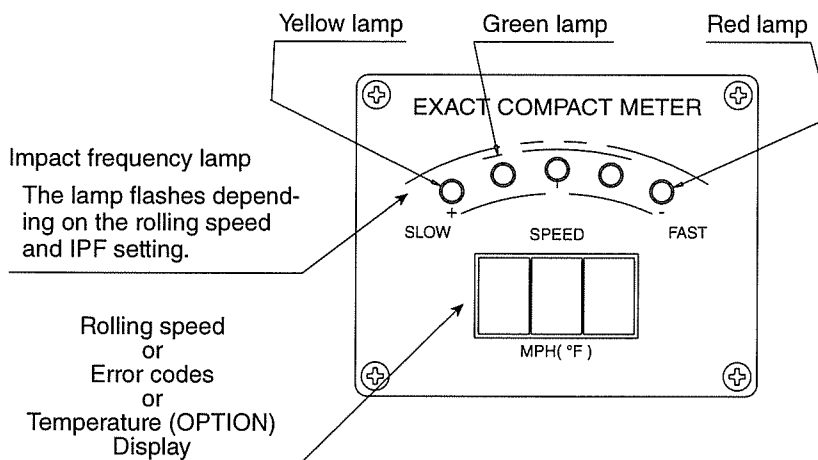



## 1) Impact frequency lamp

The position where the impact frequency lamp flashes, indicates whether actual impact frequency is greater or fewer than the preset IPF.

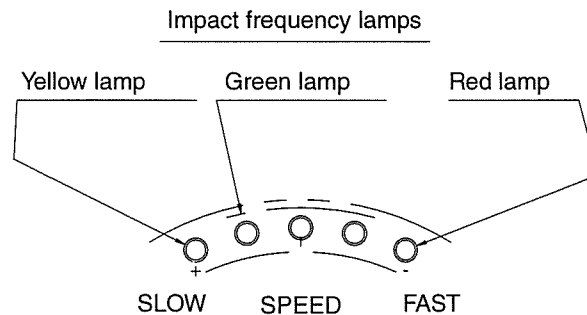

- Yellow light :  $+3 < \text{Difference comparing to IPF numbers}$   
 Left green light :  $+1 < \text{Difference comparing to IPF numbers} \leq +3$   
 Center green light :  $-1 \leq \text{Difference comparing to IPF numbers} \leq +1$   
 Right green light :  $-3 \leq \text{Difference comparing to IPF numbers} < -1$   
 Red light :  $\text{Difference comparing to IPF numbers} < -3$

## 2) Rolling speed / Error codes / Temperature display

When the ignition key is turned to the ON position, PON shows up for approximate 2 seconds.

After that, the rolling speed is displayed. If there is an error in the system, the error code is displayed.

Temperature is displayed when the Temperature / Vehicles speed selector switch is selected to F position ( NOTE: Temperature display function is OPTIONAL) .

## 2. OPERATION

### 2.6.3 Operation

- 1) When the ignition is turned to the " ON " position, the rolling speed display shows [0.0] after approximate 2 seconds. If the display shows any other message, there may be problems. See page 55 for detail.
- 2) Select the desired frequency from 2500vpm, 3000vpm, or 4000vpm by means of Vibration frequency selector switch.
- 3) Select the desired impacts per foot from 10, 11, 12, 13, 14, 15 IPF by means of the IPF selector switch.
- 4) When the vehicle travels with vibration on, the illuminated color of the impact frequency lamp moves in accordance with the rolling speed and the impacts per foot selection.
- 5) In order to execute compaction work at the desired vibration frequency and IPF setting, the work should be performed at the rolling speed where the center green light stays illuminated.
- 6) Using the AUTO SPEED function (See page 44) will assist compaction work. Following table shows reference with Frequency / I.P.F./ Propel speed..

Frequency (vpm)	I.P.F. (MPH)					
	10	11	12	13	14	15
2500	2.8	2.6	2.4	2.2	2.0	1.9
3000	3.4	3.1	2.8	2.6	2.4	2.3
4000	4.5	4.1	3.8	3.5	3.2	3.0

NOTE : Increase the rolling speed when Yellow light is illuminated.  
Reduce the rolling speed when the Red light is illuminated.

#### **⚠ CAUTION**

- When using the Exact Compact meter in vibratory mode, be sure to run the engine at FULL engine speed.
- If the engine is not running at the FULL speed position, the Exact Compact meter may display inaccurate results.

## 2.7 Vehicle Controller Diagnoses

If error code like as “ E XX ” is displayed on the EXACT COMPACT METER, some kind of error has been detected.

### ⚠ CAUTION

**When an error is detected, the engine may stop to urgently stop the vehicle.**

Error code	Function / Component	Error	Engine stop
E01	Potentiometer	Output voltage to Vehicle controller is grounded	Yes
E02	Potentiometer	Output voltage to Vehicle controller is power supply voltage	Yes
E03	Neutral switch	Short circuit to Vehicle controller	Yes
E04	Neutral switch	Broken wire	Yes
E05	Backward switch	Short circuit to Vehicle controller	Yes
E06	Backward switch	Broken wire	Yes
E11	Speed sensor	Broken wire	Yes (*)
E21	Vibration selector switch	Broken wire / Short circuit to Vehicle controller	No
E22	IPF selector switch	Broken wire / Short circuit to Vehicle controller	No
E31	Current control / Propel pump solenoid for forward	Current outside the nominal range	Yes
E32	Current control / Propel pump solenoid for backward	Current outside the nominal range	Yes
E33	Current control / Vibration pump solenoid for left	Current outside the nominal range	No
E34	Current control / Vibration pump solenoid for right	Current outside the nominal range	No
E41	CAN BUS / ECU	Signal defect to Vehicle controller	Yes (*)
E42	Display	Signal defect to display	Yes
E43	Display / Controller	Signal defect to Vehicle controller	No

### IMPORTANT

**When the vehicle controller malfunctions or fails, contact your SAKAI Dealer immediately for appropriate inspection, maintenance, or repair.**

NOTE: Refer to “Emergency traveling” on page 42 when it is necessary to move the vehicle urgently.

\* Only AUTO SPEED mode, see 2.3.7 AUTO SPEED.

## 2.8 Precautions for Work

### 2.8.1 Compaction operation

#### ■ Do not operate the vibrator on a hard surface

- Do not work the vibrator on a hard surface such as concrete pavement, as this can cause the machine to jump and give abnormal shock load. Damage to shock isolators will result.

#### ■ Change the direction of travel gently

- When changing the direction of travel during asphalt mix compaction, slowly shift the F-N-R lever.

### 2.8.2 When going downhill

#### ■ Use the F-R lever

- Run slowly going downhill. Do not use excessive speed. Avoid changing speed if possible when going downhill. Start slowly and end slowly on steep downgrades.

#### ■ Use the engine brake

- Go downhill by applying the engine brake along with the F-N-R lever operation.

### 2.8.3 On a slope

#### ■ Working on a sidehill

- Work in an uphill / downhill direction, and avoid working on sidehill with the machine inclining sideways.

## 2.9 Applicable Jobs

The machines do a variety of jobs as listed below:

### Work

- Asphalt road paving
- Dust removal treatment for road
- Road improvement
- Embankment construction
- Dam construction
- Construction of forestry and farm roads
- Foundation building
- Construction of sidewalk, shoulder and gutter foundation

### Material to be compacted

- Asphalt pavement
- Crusher run
- Cement concrete

- Sands
- Soils
- Slag
- Soft rock
- Roller compacted concrete

**Layers to be compacted**

- Surface course, Binder course
- Base course
- Subgrade
- Embankment
- Shoulder
- Sidewalk

**2.10 After Operation**

Check for the coolant temperature, engine oil pressure and fuel level.

Follow the procedures below to prevent the machine from falling into an unworkable condition the following morning caused by muds and other extraneous matter on the drum, or frozen drums:

- 1) Remove soil and water from the machine. Muds can get into the seals together with water drops on the hydraulic cylinder piston rod. Damaged seals will result.
- 2) Park the machine on a hard and dry surface. If such a place is not available, cover the ground with hard plates.
- 3) Low temperature will cause a significant reduction of battery efficiency. Cover batteries or take them off the machine and store in a warm place for the following day's operation.
- 4) To prevent freezing, drain water from the spray system (See Water spray system on page 51).

**IMPORTANT**

**Insufficient draining of water can cause damage to the machine.**

## 2. OPERATION

### 2.11 Loading and Unloading

#### ⚠ WARNING

- Use sturdy ramps with proper width, length and thickness which allow safe loading and unloading.
- If the ramps deflect considerably under load, apply wooden blocks to reinforce them.
- Loading should be conducted on a level and hard ground. Leave a sufficient distance between the machine and the shoulder.
- To prevent slippage on the ramps, keep the drums free from mud, oils, etc. The ramps must also be free of grease, oil and ice.
- Do not steer the machine on the ramps. If the machine is facing in the wrong direction, allow it to dismount from the ramps and correct the direction.

For loading and unloading, use ramps or a proper loading stand.

#### 2.11.1 Use of a trailer equipped with a winch

#### ⚠ WARNING

Placing the unloader valve in UNLOAD position disrupts the power for traction. Do not enter the areas ahead of and behind the machine. It is very dangerous.

- 1) Engage the trailer brake and chock its wheels. Fix the ramps so that the machine and trailer are completely aligned.
  - ☆ The angle between the ramps and ground must be less than 12 degrees.
  - ☆ Leave a proper space between the ramps according to the width of the roller drum.
- 2) Decide the correct direction of run and make the machine run forward to the ramps.
- 3) Draw the wire rope from the trailer winch and put its hook on the hooking point ① or ② (One each on right and left) of the roller.
- 4) Place the unloader valve located at the engine room to the UNLOAD position (See “Unloader valve” on page 31).

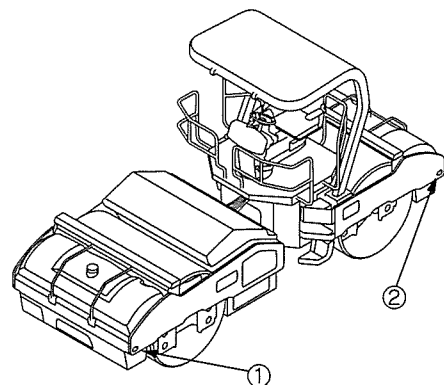
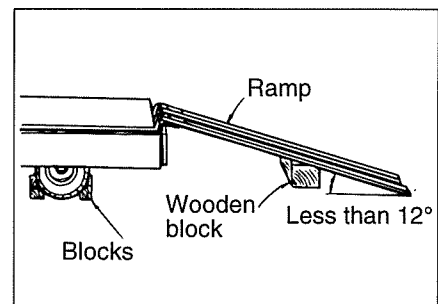

- 5) With the engine running at idle, perform loading by means of the trailer winch.
- 6) When the loading is completed, set the unloader valve back in the ONLOAD position.
- 7) Correctly secure the machine to the trailer for transport.

### 2.11.2 Self-propelling

- 1) Engage the trailer brake and chock its wheels. Fix the ramps so that the machine and trailer are completely aligned.

☆ The angle between the ramps and ground must be less than 12 degrees.

☆ Leave a proper space between the ramps according to the width of the roller drum.

- 2) Decide the correct direction of run and conduct loading or unloading at low speed.

For loading, run forward at low speed.

For unloading, run backward at low speed.

- 3) Locate the machine correctly on the trailer.

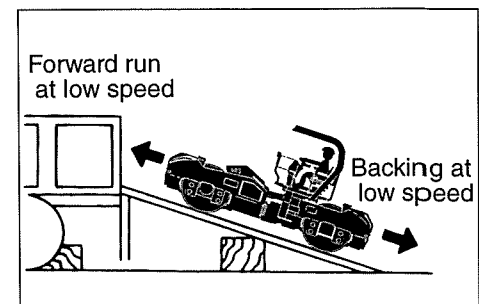
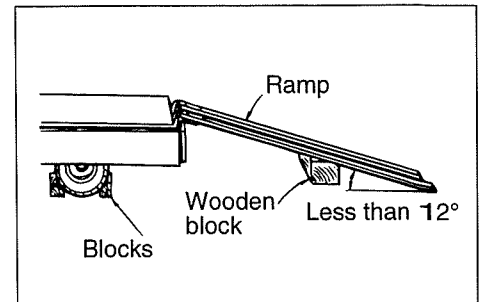

### 2.12 After Loading the Machine

When the machine has been located properly on the trailer, tie it down as follows:

- 1) Press the parking switch button to apply the parking brake. Place wooden blocks under the drums to prevent movement.
- 2) Fix the machine with ropes tied at the front and rear towing hook holes. Particularly, pay attention to sideways skidding.

## 2. OPERATION

### 2.13 Transportation

#### **⚠ WARNING**

To decide the transporting route, check the width of the road, height and weight (including the roller) of the trailer. Obey relevant regulations.

For transportation, obey traffic regulations.

### 2.14 Operation in Cold Weather

In cold weather, take the following measures to prevent troubles such as starting difficulty and coolant freeze-up.

#### 2.14.1 Fuel oil and grease

Use fuel and oil with low viscosity. See " Rating " on page 86.

#### 2.14.2 Coolant

#### **⚠ WARNING**

Do not bring an open flame to the antifreeze or do not smoke when handling it. It is inflammable.

#### **⚠ CAUTION**

Never use methanol-, ethanol- and propanol-base antifreeze.

Use soft water for coolant.

In freezing weather, add antifreeze to the coolant referring to the table below. Select the most suitable mix ratio according the lowest temperature in the job location.



SW880

CAPACITY LITER (QUART)

Ambient temperature	-33°C (-27.4°F)	-26°C (-14.8°F)	-20°C (-4°F)	-16°C (3.2°F)
Amount of anti-freeze	8.5 ℓ (9.0)	7.7 ℓ (8.1)	6.8 ℓ (7.2)	6.0 ℓ (6.3)
Amount of water	8.5 ℓ (9.0)	9.3 ℓ (9.9)	10.2 ℓ (10.8)	11.0 ℓ (11.7)
Ratio	50 %	45 %	40 %	35 %

SW990

CAPACITY LITER (QUART)

Ambient temperature	-33°C (-27.4°F)	-26°C (-14.8°F)	-20°C (-4°F)	-16°C (3.2°F)
Amount of anti-freeze	9.5 ℓ (10.0)	8.6 ℓ (9.0)	7.6 ℓ (8.0)	6.7 ℓ (7.0)
Amount of water	9.5 ℓ (10.0)	10.5 ℓ (11.0)	11.4 ℓ (12.0)	12.4 ℓ (13.0)
Ratio	50 %	45 %	40 %	35 %

Long life coolant is used in our roller. Useful life of this antifreeze coolant is 2 years.

**IMPORTANT**

**Use of a high consistency antifreeze coolant in summer time can cause the engine to overheat depending upon job conditions. Use a coolant with the water-antifreeze ratio of 65 to 35.**

## 2. OPERATION

### 2.14.3 Battery

#### **⚠ WARNING**

- **Batteries generate explosive gases. Do not use an open flame close to batteries.**
- **The battery electrolyte is corrosive. Keep the electrolyte away from your eyes and skin. If you are affected by the electrolyte, flush with large quantities of water and get medical help.**

At low temperature, batteries are less efficient. The level of charge is lowered and batteries will tend to freeze. Maintain batteries fully charged wherever practicable, and give attention to heat insulation at night for the next day's operation.

For the level of charge, check the specific gravity of electrolyte and use the following table of conversion.

Temperature Level of charge (%)	20°C (68°F)	0°C (32°F)	-10°C (14°F)	-20°C (-4°F)
100		1.29	1.30	1.31
90	1.26	1.27	1.28	1.29
80	1.24	1.25	1.26	1.27
75	1.23	1.24	1.25	1.26

### 2.15 When the Cold Season is Over

When winter is over and the warm season has come, proceed as follows:

- 1) Change oil and fuel with those for use in warm season referring to "Rating" on page 86.
- 2) If AF-PT antifreeze is in use, drain the coolant completely, wash clean inside the cooling system, and then fill with clean water (city water).

## 2.16 For a Long Storage Period

For leaving the machine unused for longer than one month, proceed as follows:

- 1) Store the machine in a closed area after cleaning.
- 2) Conduct oiling, greasing and changing of oil.
- 3) Grease lubricate the exposed portion of hydraulic cylinder piston rods.
- 4) Cover the battery after disconnecting the negative cable or take off the battery from the machine and store in a safe place.
- 5) If the temperature is expected to go down below 0°C, add antifreeze to the coolant.
- 6) Completely drain the spray system.
- 7) Place the F-N-R lever in the neutral position (N), and apply the parking brake.
- 8) Chock the machine.
- 9) Remove the ignition key.

## 2.17 During the Storage Period

### **⚠ WARNING**

**If necessary to operate the machine in indoor storage space, ensure good ventilation keeping windows and doors open to prevent gas poisoning.**

During storage, operate the machine at least once a month to prevent the oil films on the lubricated parts from deteriorating and to charge the batteries.

## 2.18 When the Battery has Discharged

### ⚠ WARNING

- To check and handle the batteries, keep the engine stopped with the starter switch in the OFF position.
- The batteries give off explosive gases. Do not smoke close to the batteries. Keep flames and sparks away from the batteries.
- The electrolyte is very corrosive and will harm your clothing or skin. If the electrolyte has come into contact with your clothing or skin, flush with sufficient amount of water. In case the electrolyte has gotten into your eyes, flush with water and get medical help.
- To disconnect the battery cables, start with the negative terminal (earth). When connecting, start with the positive terminal. Do not allow a metallic item to bridge between the positive terminal and machine body. This can generate sparks, causing an explosion.
- Loose battery terminals can cause sparks. An explosion will result. When connecting the terminals, make certain that they are tight.

Disconnect with negative cable first

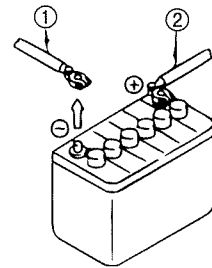

Connect with positive cable first

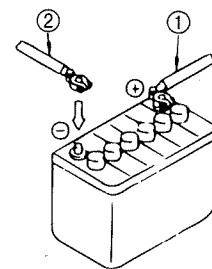

### 2.18.1 Connection and disconnection of booster cables

When jump-starting the engine, connect the booster cables as follows:

#### ■ Connection of booster cables

- 1) Connect one end of the positive booster cable (A) to the positive  $\oplus$  terminal of the dead battery on the machine.
- 2) Connect the other end of the positive booster cable to the positive  $\oplus$  terminal of the live power supply.
- 3) Connect the negative booster cable (B) to the negative  $\ominus$  terminal of the live power supply.
- 4) Connect the other end of the negative booster cable to a good earth ground on the engine block of the machine.

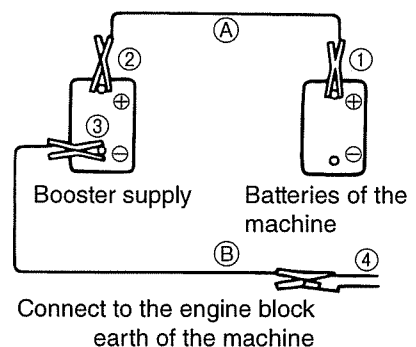

### ■ Disconnection of booster cables

- 1) Disconnect the negative booster cable (B) from the engine block earth.
- 2) Disconnect the negative booster cable (B) from the booster supply.
- 3) Disconnect the positive booster cable (A) from the booster supply.
- 4) Disconnect the positive booster cable (A) from the machine.

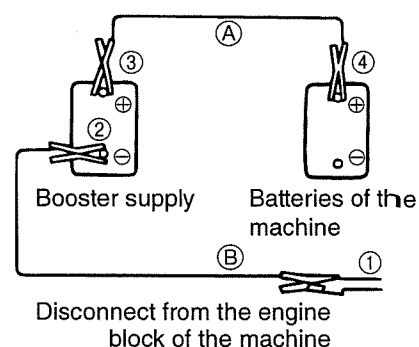

### ⚠ WARNING

- Do not allow the positive  $\oplus$  terminal to make contact with the negative  $\ominus$  terminal when connecting the booster cables.
- Wear safety goggles when jump-starting the engine.
- Do not allow the machine to make contact with the booster supply.
- Do not make wrong connections. Connect the negative  $\ominus$  cable to the engine block earth far away from the battery, as sparks may occur when connecting.

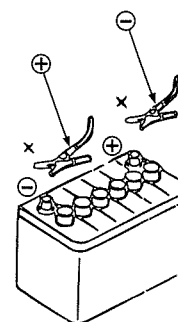

### ⚠ CAUTION

- Use booster cables and end clips of proper size suited to the battery capacity.
- Use the batteries of the equal capacity for the machine and booster supply.
- Check booster cables and end clips for signs of damage and corrosion.
- Securely connect the clips.

## 3 PERIODIC MAINTENANCE

### 3.1 Precautions

Whether or not the inspection service and lubrication are performed at the correct regular intervals exerts significant influence on the occurrence of problems and service life of the machine. In this manual, typical intervals for inspection and service are given. However, flexibility should be exercised as to interval or type of services to enable your machine to always operate in the best condition.

#### **IMPORTANT**

**After maintenance and inspection, record the result of inspection. Remember that replacement of filters and elements, replenishment and change of oil and grease, and cleaning of the radiator fins is important.**

#### **General precautions**

- 1) Always use Sakai genuine parts for replacement.
- 2) Use lubricants recommended by Sakai. Avoid mixing different brand lubricants.
- 3) For hydraulic oil replenishment, changing, level checking, filter cleaning or replacement, oiling and greasing, use extreme care to prevent dust from entering.
- 4) For checking oil level or changing oil, park the machine on a level and hard surface.
- 5) Change oil while its temperature remains high after operation.
- 6) For a long-term storage, fill the fuel tank, lubricate necessary points and run the machine for more than 20 minutes once a month.
- 7) In freezing weather, add antifreeze to the coolant according to the ambient temperature.
- 8) For the hydraulic pump and motor, have them serviced at authorized service shops.
- 9) Turn the starter switch OFF when performing services such as repairing broken wires, short circuits and tightening loose terminals.

#### **Periodic replacement of essential maintenance parts**

In order secure safety for work and travel, conduct inspection and services.

Further, for enhanced safety, following parts and components should be replaced periodically. These parts are prone to material deterioration due to aging or physical change due to wear, it is difficult to determine their useful limit by regular inspection, which makes it necessary to replace with new ones after certain period of service to ensure they function as intended. If any defects are detected such as crack, deformation, wear or oil leakage, go ahead and replace them even if it is within scheduled replacement time.

### 3. PERIODIC MAINTENANCE

System or Mechanism	Part name	Periodical replacement maintenance part	Replacement period	Remarks
1 Brake system	Master cylinder	Seals (rubber parts)	2 years	
	Wheel cylinder	Seals (rubber parts)	2 years	
	Brake piping parts	Brake hose	2 years	
		Air hose	2 years	
	Operating parts	Cable	4 years	
2 Steering system	Orbitrol	Seals (rubber parts)	2 years	
	Hydraulic piping parts	Hydraulic hose	2 years	
	Steering cylinder	Seals (rubber parts)	2 years	
	Hydraulic pump	Seals (rubber parts)	4 years	
3 Power transmission system (inclusive of axle)	Axle	Seals (rubber parts)	4 years	
	Travel pump	Seals (rubber parts)	4 years	
	Travel motor	Seals (rubber parts)	4 years	
	Hydraulic piping parts	Hydraulic hose	4 years	
	Isolation rubber	Isolation rubber itself	4 years	
4 Fuel system	Piping parts	Fuel hose	2 years	
5 Engine related	Engine mounting parts	Isolation rubber	4 years	
	Seals (rubber parts)	Packing and others	4 years	
	Drive parts	V-belt	2 years	or 500 hours
	Piping parts	Engine drain hose	4 years	
6 Cooling system	Piping parts	Radiator hose	2 years	
		Radiator drain hose	4 years	
7 Control related parts	Cable	Cable	4 years	
8 Intake system	Piping parts	Intake hose	2 years	
		CAC hose	2 years	
9 Flood system	Hydraulic piping parts	Fuel hose	4 years	

#### ⚠ CAUTION

- With a new machine, change the engine oil and change the engine oil filter element after 50 hours of operation for the first time only. (Refer to page 74)
- When trouble occurs in the location indicated by the indicator lamp on the dashboard display, sensor will work and corresponding lamp comes on. If this occurs, conduct necessary service regardless of the periodical service interval recommendation.
  - 1) The hydraulic filter (line filter) warning lamp ⇨ Replace elements
- Check the electric wiring at a regular interval not exceeding one month:
 

If there are some trouble on the electric wiring, replace them with new one.

  - 1) Damage to the wire harness and loose clamps
  - 2) Loose sockets
  - 3) Function of electrical systems
- For the parts other than listed above, if there are some trouble on the parts at periodical inspection or daily check, replace them as soon as possible.

### 3. PERIODIC MAINTENANCE

#### 3.1.1 Lifting the machine on a hoist

##### ⚠ WARNING

- Get qualified personnel to lift and lower the machine on a hoist.
- Use sturdy wire ropes.
- Lock articulation by means of lock bar located at the center of machine.

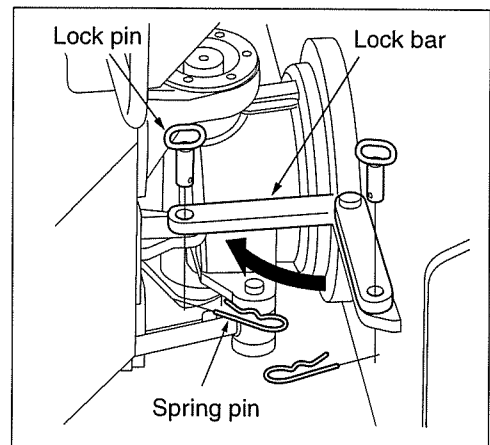
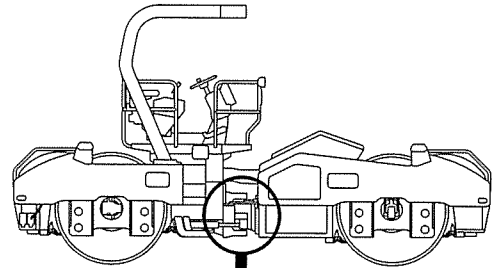

##### ⚠ CAUTION

Remove rops before starting lifting work.

1) Put wire ropes securely on the hook and lifting points as shown.

NOTE: Use appropriate wire rope size.

- 2) If wire ropes make contact with other parts of the machine, put pieces of cloth or wooden blocks at the contact points. Carefully perform lifting.
- 3) When lifting, keep the machine properly ballanced.

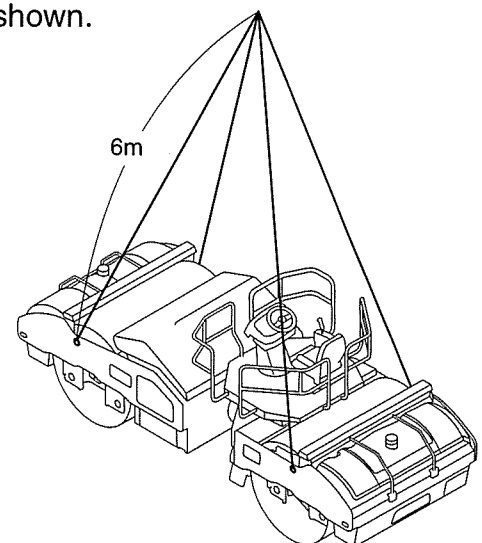

##### ⚠ WARNING

Make sure wire ropes are not damaged.



### 3.2 Walk-around Checking

For efficient operation, daily, before-operation checking is very important. Before starting, perform walk-around checking for loose bolts, nuts and signs of leakage in addition to items as shown below:

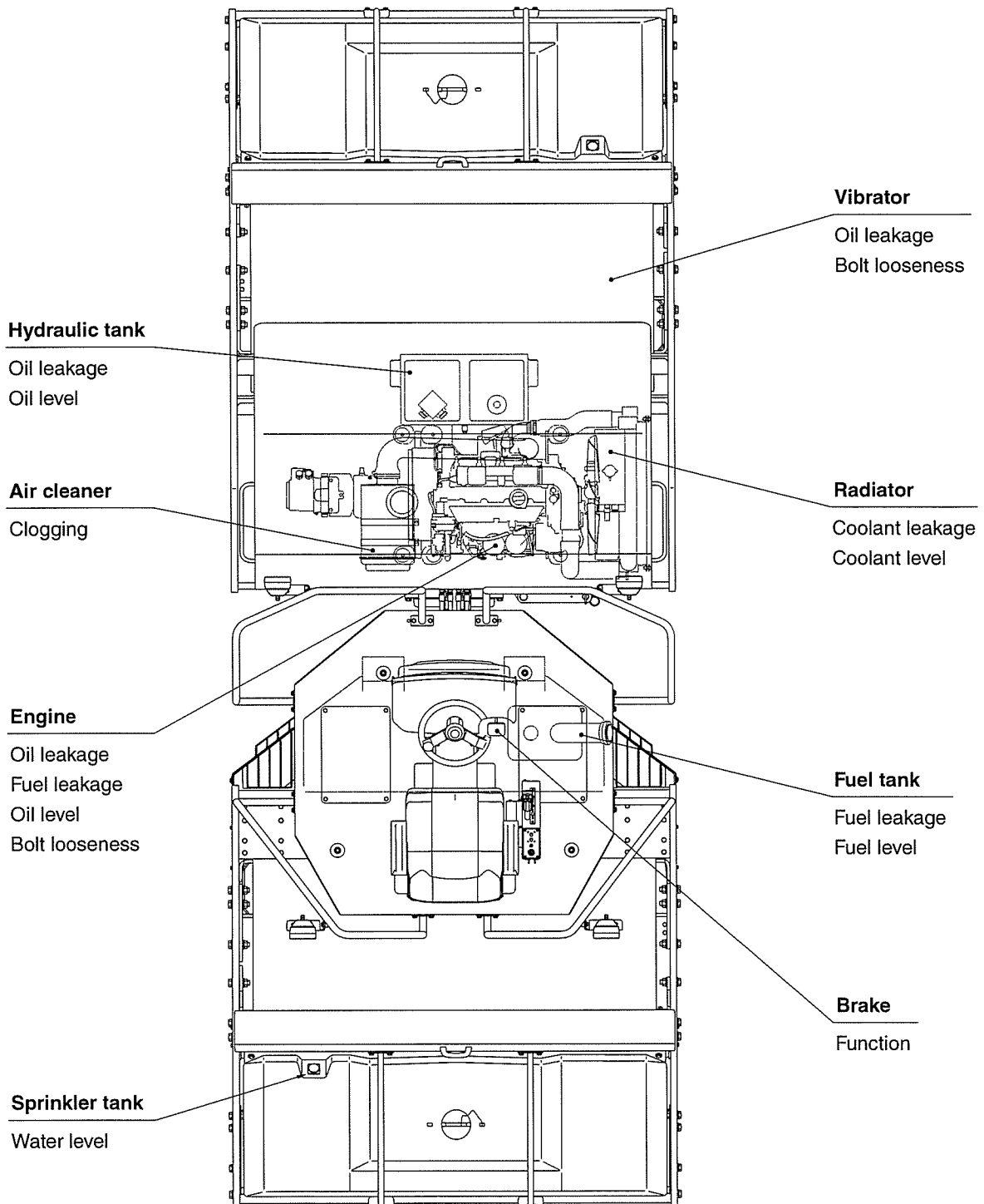

### 3. PERIODIC MAINTENANCE

#### 3.3 Periodic Maintenance Points

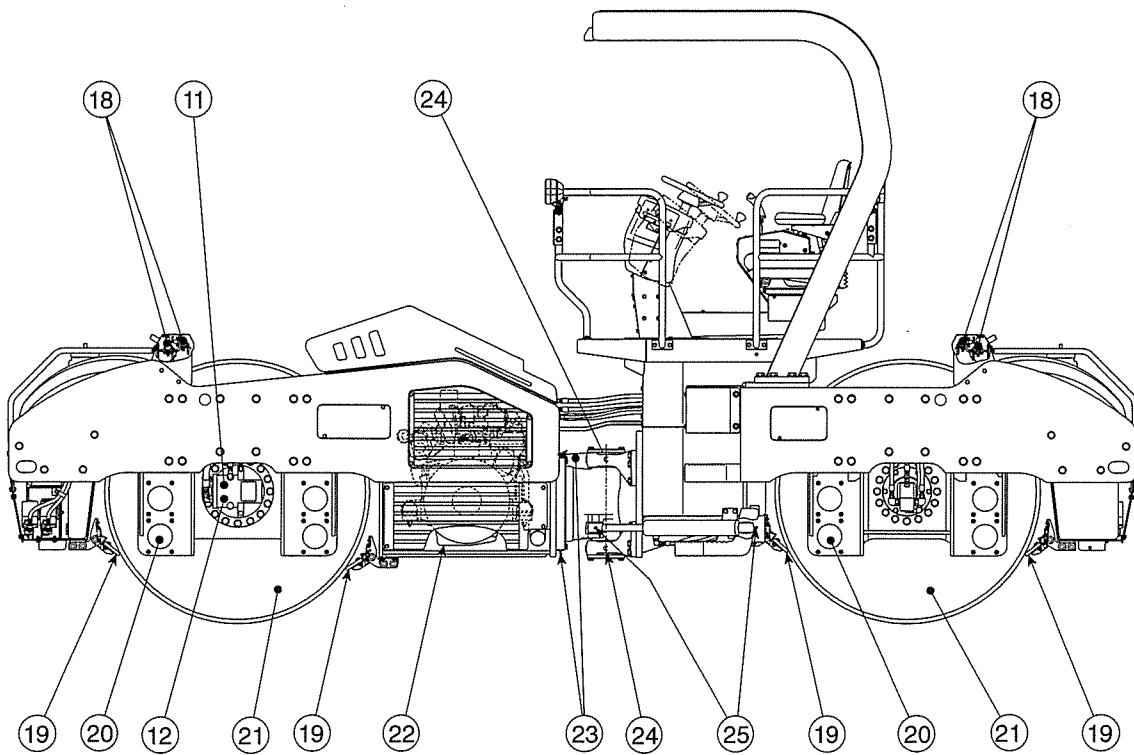
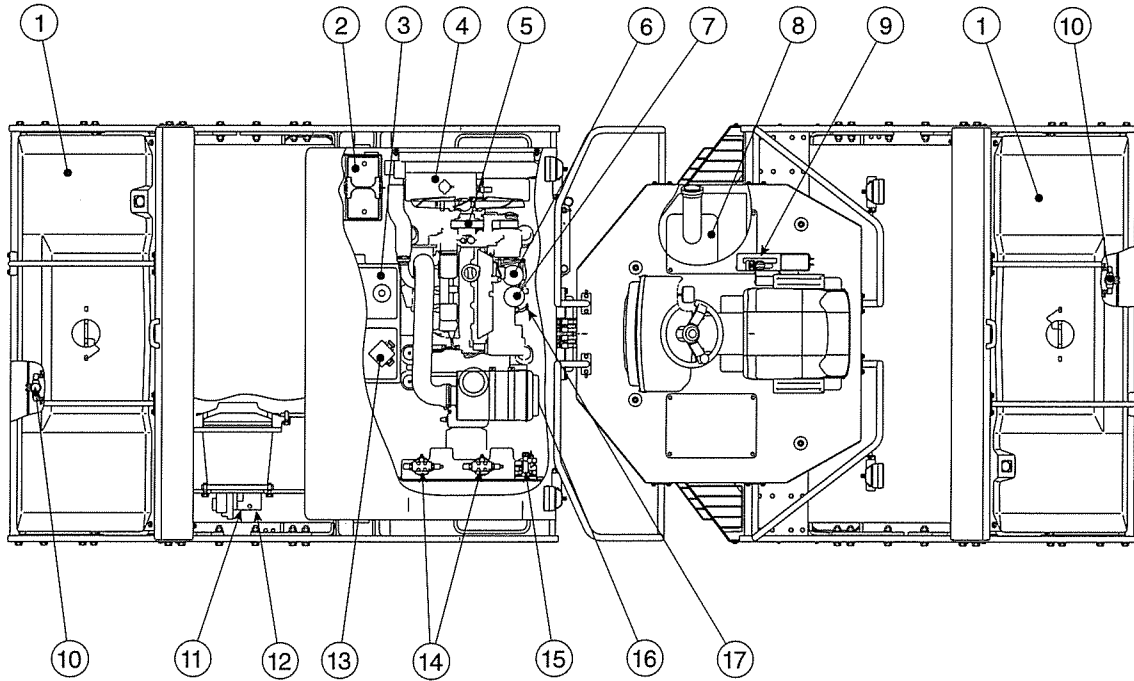

### 3. PERIODIC MAINTENANCE

Interval	Ref. No.	Item	Service	Lubricant	Q'ty
Every 10 hours or daily	④	Radiator reserve tank	Check coolant level, add as necessary	Coolant	1
	⑰	Engine oil level gauge	Check oil level, add as necessary	Engine oil	1
Every 50 hours	②	Battery	Check looseness of terminal	Battery fluid	1
	③	Hydraulic oil tank	Check oil level, add as necessary	Hydraulic oil	1
	⑩	Water filter	Clean element		2
	⑮	Fuel sedimenter (with fuel prefilter)	Check and drain water and dirt		1
Every 250 hours	⑤	Fan belt	Check looseness, adjust as necessary		1
	⑥	Engine oil filter	Change element		1
	⑱	Spray bar, nozzle	Clean		4
	⑳	Shockmounts (Roll mount)	Check cracks		24
	㉑	Vibrator	Check oil level	Gear oil	2
	㉒	Engine oil pan	Change oil	Engine oil	1
Every 500 hours	⑦	Fuel filter	Replace element		1
	⑨	Control unit	Check looseness and adjust Apply grease	Grease	1
	⑭	Line filter	Replace element		2
	⑮	Fuel prefilter (with fuel sedimenter)	Replace element		1
	㉓	Tilt pin bearing	Apply grease	Grease	2
	㉔	Center pin bearing	Apply grease	Grease	2
	㉕	Steering cylinder	Apply grease	Grease	4
Every 1000 hours	③	Hydraulic oil tank	Change oil	Hydraulic oil	1
	⑪	Gear case / Wheel motor	Change oil	Gearoil	2
	⑫	Brake	Check brake disk thickness or replace		2
	⑬	Suction filter	Clean element		2
	㉑	Vibrator	Change oil	Gearoil	2
As required	①	Water tank	Clean inside		2
	⑧	Fuel tank	Clean inside		1
	⑯	Air cleaner	Clean or replace element		1
	⑲	Scraper	Adjust or replace blade		4

### 3. PERIODIC MAINTENANCE

#### 3.4 Maintenance Procedure

➔ For servicing the engine, see the separate engine manual.

##### (1) Every 10 hours or daily

##### ④ Radiator reserve tank

Check to see coolant level in the sight glass, if coolant can not be seen, replenish with the tank cap removed. Use soft water only.

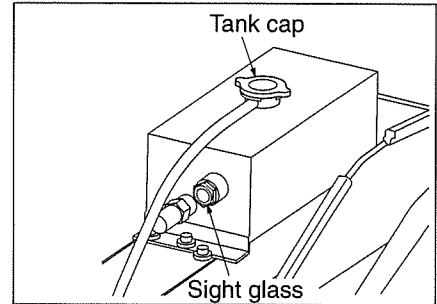

##### ⚠ WARNING

Do not remove the radiator cap while the coolant is hot.



##### ⑰ Engine oil level gauge

Shut down the engine and check the engine oil level. If it is not between MAX and MIN marks, add oil through the fill hole.

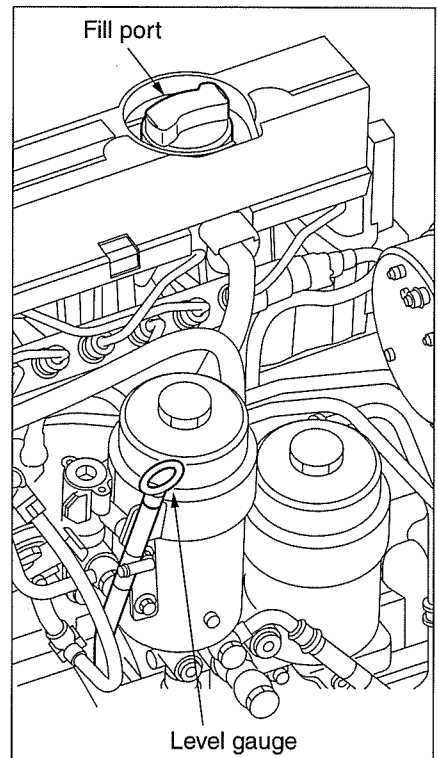

(2) Every 50 hours

② Battery

- 1) When the terminal is loose, tighten it up and thinly apply vaseline or grease for rust prevention.
- 2) Check that there is no abnormality on the surface.

③ Hydraulic oil tank

Check the oil level with the sight glass on the side of tank. The level is proper if it is aligned with the red line between H and L marks when cold. Of necessary, add the hydraulic oil from the fill port.

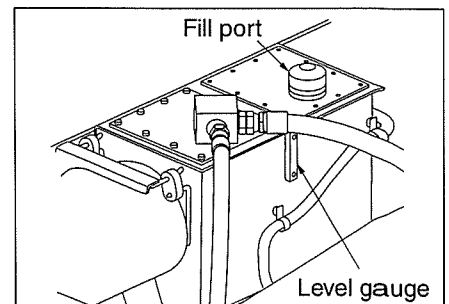

⑩ Water filter

Take off the filter bowl by turning counter-clockwise as viewed from the bottom. Clean the element.

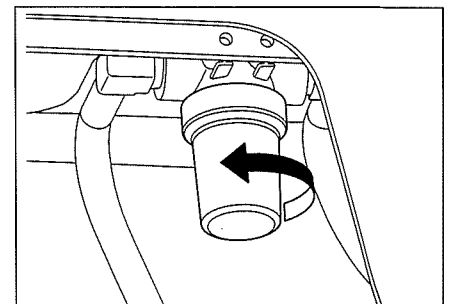

⑮ Fuel sedimenter

Drain water by turning clock - wise as viewed from the top.

➔ See the separate engine manual.

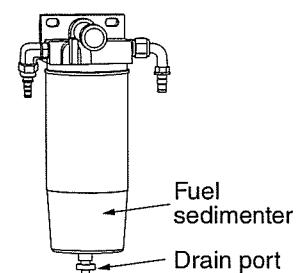
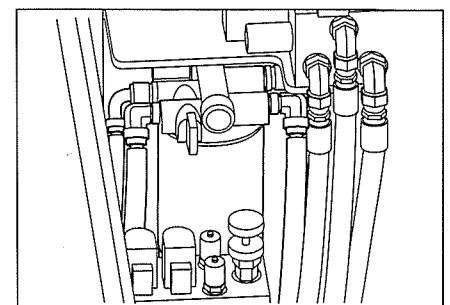

### 3. PERIODIC MAINTENANCE

#### (3) Every 250 hours

##### ⑤ Fan belt

- 1) Check the fan belt for wear and damage. Replace as necessary.
- 2) The wear limit of the V-rib belt is checked as below:  
Check the distance between the projection of the moving tension arm and the contact with the fixed tensioner housing.  
If the distance "a" is less than 3 mm, the V-rib belt should be changed.

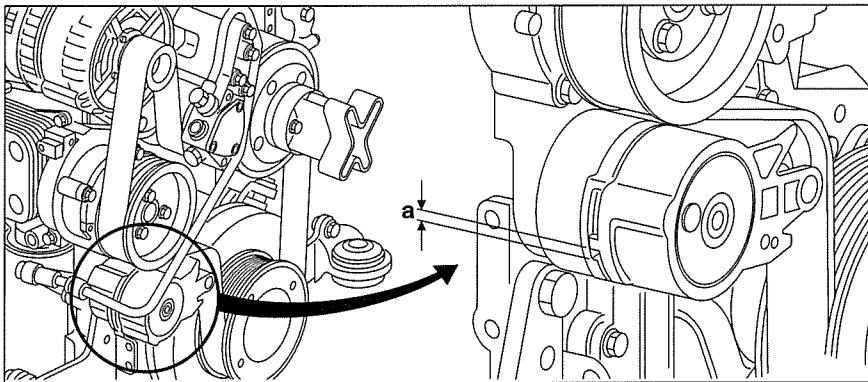

#### 3) V-rib belt tension:

The V-belt has a spring-loaded tension pulley which tightens automatically and is not re-tightened.

##### ⑥ Engine oil filter

##### ⑳ Engine oil pan

➔ See the separate engine manual.

- 1) After completion of operation and while the oil is warm, drain the oil with the drain plug removed.

#### ⚠ WARNING

When draining a hot oil, use care not to get burned.

- 2) Refit the drain plug and fill the crankcase with the engine oil from fill port on the cylinder head cover.
- 3) Change the oil filter

NOTE: For a new machine, change oil at 50 operating hours for the initial time only.

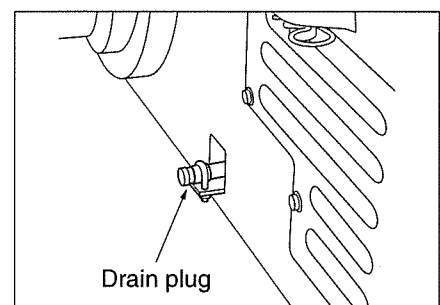
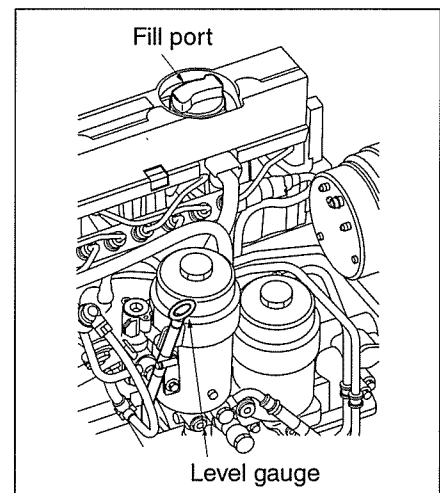

### 3. PERIODIC MAINTENANCE

#### 18 Spray bar, nozzle

- 1) Spray bar
  - Remove the cap from both ends of each spray bar.
  - Operate the spray pump to wash out dust from inside the pipe.
- 2) Nozzle
  - Remove the nozzles from the spray bars and separate the filter from each nozzle.
  - Clean the filters. Use a needle or the like to clean nozzle hole. Refit the filters to the nozzles.
  - Fit the nozzles to the pipes so that the water is sprayed in the form of a hand fan in parallel with the pipe.

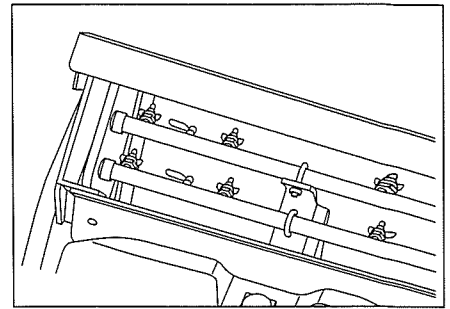

#### 20 Shock mounts : Roll mount

Check the rubber blocks for cracks, and their mounting bolts for looseness.

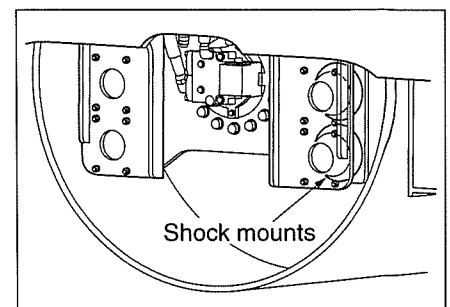

#### 21 Vibrator

Check for the oil level and leakage.

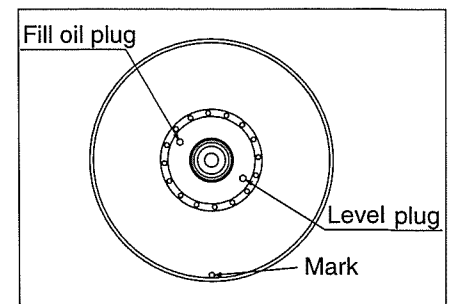

### 3. PERIODIC MAINTENANCE

#### (4) Every 500 hours

⑦ Fuel filter

⑮ Fuel prefilter

➔ See the separate engine manual.

Change the filter cartridge.

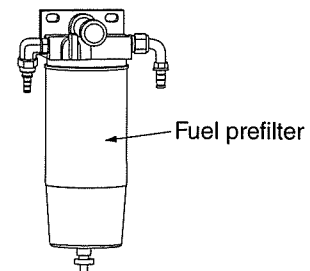
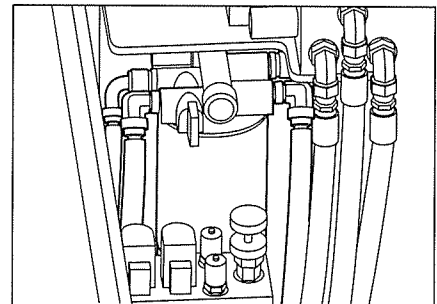
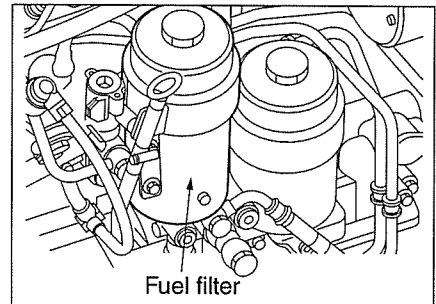

⑨ Control unit

Remove the cover.  
Check the bolts and nuts for looseness.

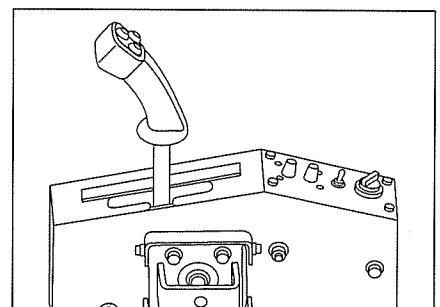

⑭ Line filter

Turn-out and remove filter element by turning it counter clockwise before replacing it.

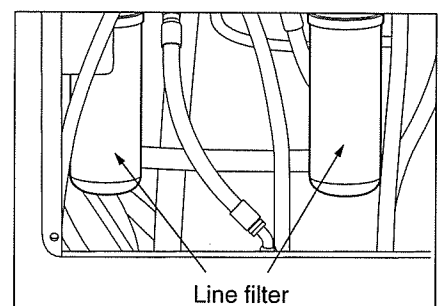



### 3. PERIODIC MAINTENANCE

#### ②③ Tilt pin bearing

#### ②④ Center pin bearing

Grease lubricate two locations.

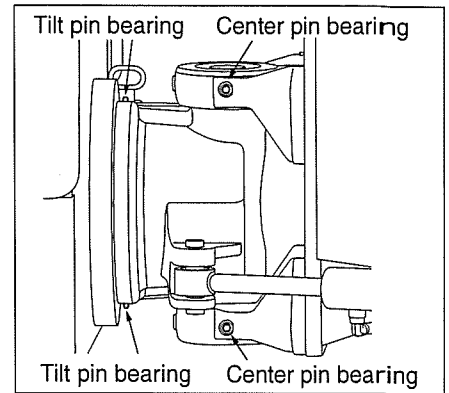

#### ②⑤ Steering cylinder : 2 pieces

Grease lubricate four locations.

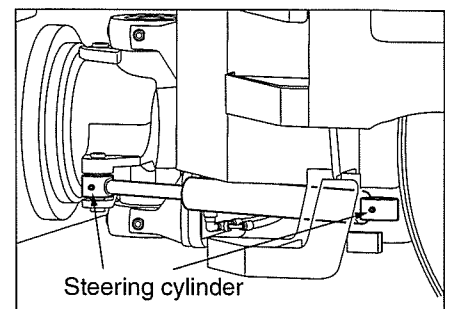

### (5) Every 1000 hours

#### ③ Hydraulic oil tank

- 1) Remove the drain plug, and drain oil while it is warm.
- 2) Clean inside of the tank, and fill fresh oil to the specified level.
- 3) Start and run the engine at idling for 2 to 5 minutes. When the hydraulic oil has become free from air bubbles, stop the engine and recheck the oil level.

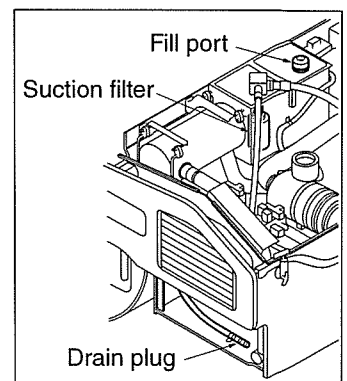

#### ①① Gear case / Wheel motor

- 1) Position it so that drain plug comes to the bottom.
- 2) While oil is warm, drain it with drain plug and level plug removed.
- 3) Rotate the roll so that drain port comes to top (or side) and level plug to side (or top). Feed oil until it overflows from the level port.
- 4) Replace the drain plug and level plug to original positions.

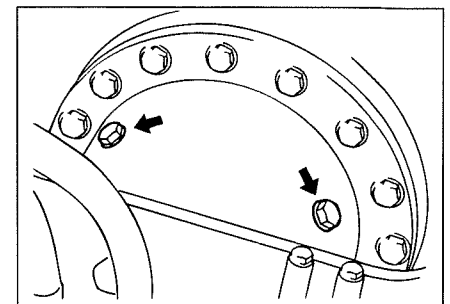

#### ⚠ WARNING

When draining a hot oil, use care not to get burned.

### 3. PERIODIC MAINTENANCE

#### 12 Brake

- 1) Loosen hex socket bolts (6 bolts) which have been fixing end cap.  
Loosen them uniformly because the brake spring tends to push up the end cap.

Bold size	M16 × 50L
Hex socket head across flats	14

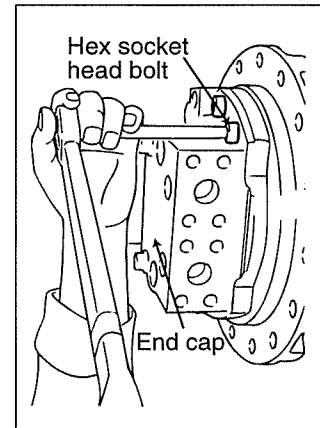

#### ⚠ CAUTION

Mating surfaces of end cap, valve plate and cylinder block having been lapped, care should be taken not to damage them.

- 2) Remove following parts which will be exposed after removing the end cap.

Item	Quantity
Valve plate	1
Brake spring	8
Pin	2
O-Ring (large)	1
O-Ring (Small)	1

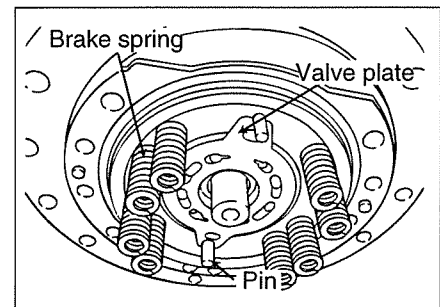

It is recommended that O-Rings are replaced with new ones.

- 3) Blowing compressed air of 2-3 kgf / cm<sup>2</sup> into hole shown in sketch, brake piston will come up. (Have the opposite side hole plugged.)  
Or, with M10 x 25 ~ 30L bolt turned into tapped hole at 2 locations of brake piston, lift it alternately using a wrench or the like as fulcrum point.

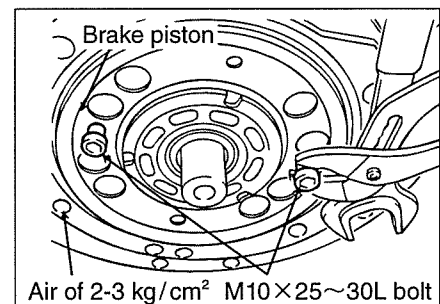
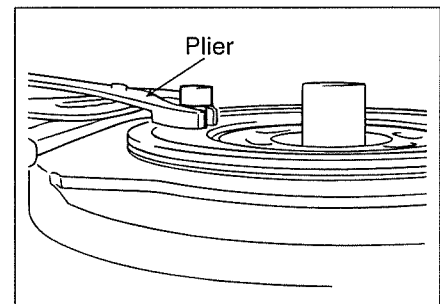

### 3. PERIODIC MAINTENANCE

4) Take out separate and friction plates. Using a wire with its end bent, will allow you to take them out more easily.

Item	Quantity
Separate sheet	4
Friction plate	3

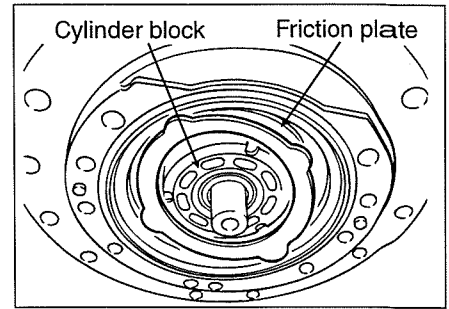

#### ⚠ CAUTION

**Do not pull out the cylinder block. Pulling it out at this stage makes it impossible to reassemble.**

5) Install separate plate and friction plate alternately. Be careful to install them in the correct quantity and order.

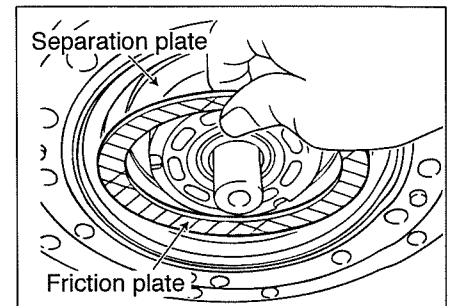
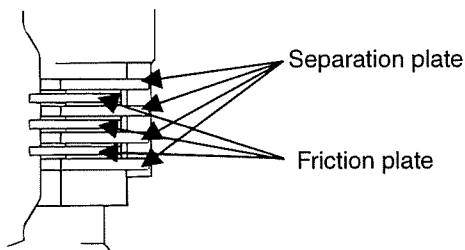

6) Remove brake releasing port plug (19 across flats) from end cap. Sub-assemble, with M10 bolt, the brake spring, valve plate and pin so that they are held between the end cap and brake piston (provisional assembling).

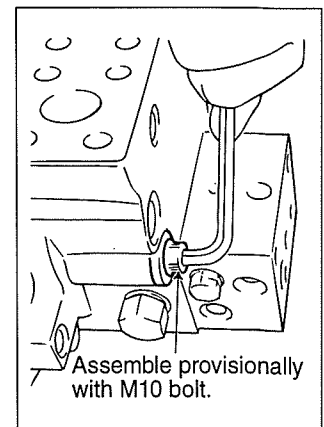
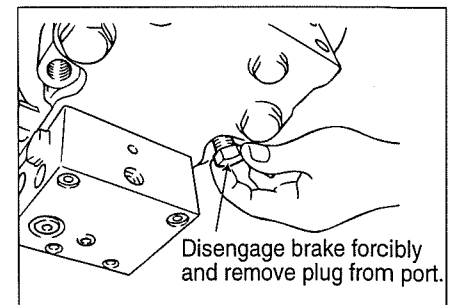
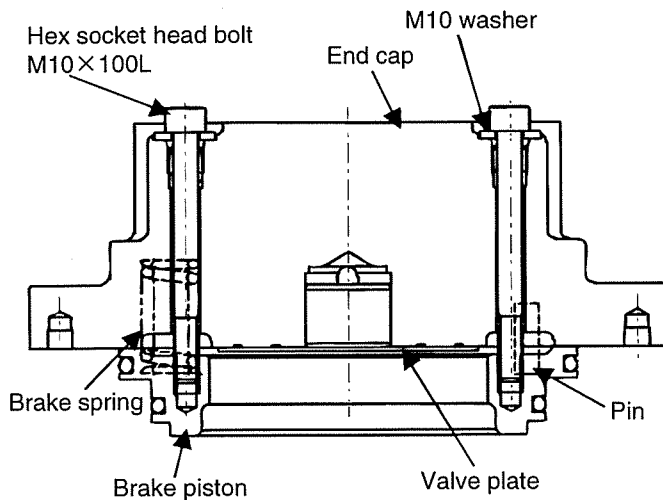

### 3. PERIODIC MAINTENANCE

7) Tighten thus sub-assembled end cap to the housing with hex socket head bolt.

**⚠ CAUTION**

**Install as straightly as possible so that the shaft end does not damage journal bearing which has been press-fit to end cap.**

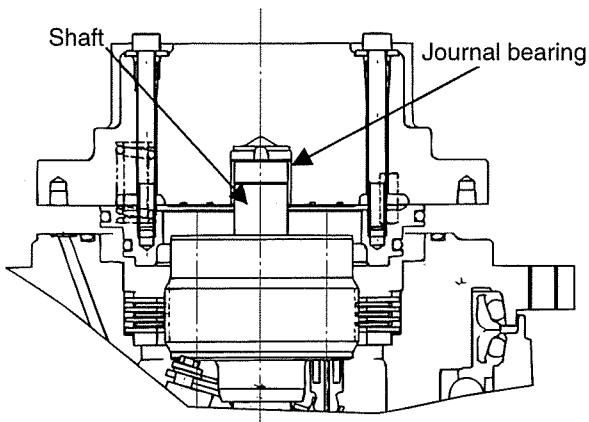

Remove M10 bolt for provisional assembly and install formal plug.

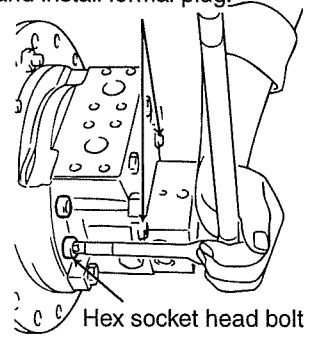

< Tightening torque for the hex socket head bolt >

Bolt size	M16 × 50L
Tightening torque	340-425 ft lb

< Tightening torque for the hex socket head bolt >

Plug size	9 / 16-18 UNF
Tightening torque	40-70 ft lb

**List of replacement parts**

It is recommendable that, in addition to friction and separate plates, relevant O-Ring are replaced with new ones as well.

No	Item	Quantity	Drawing # (DAIKIN Dwg.# (Standard JIS Nominal)
			BMV75, BM75
7	O-Ring	4 (2)	KP1B010A / 1BP10A
29	Separate plate	4	1731874
30	Friction plate	3	SP1051
33	O-Ring	1	KG1B185 / 1BG185
34	O-Ring	1	SP1092 / WG45
37	O-Ring	1	KG1B160 / 1BG160

NOTE: Quantity for No.7 O-ring: 4 for BMV75 and 2 for BM75.

For BMV series, as the seal for the second speed selection passage, 2 more are in use than for BM series.

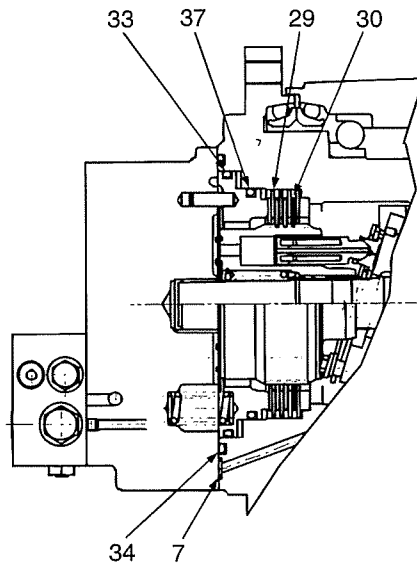

If it falls in any of the following cases, without waiting for 1,000 operating hours, replace the friction and separate plates altogether.

- 1) When the braking force becomes weaker than driving force of hydraulic motor (Despite that the brake is being actuated, hydraulic motor rotates when HST drive is engaged)  
 Checking procedure: While depressing the parking brake switch, open the throttle fully and engage the reversible travel lever. If traveling starts, replace the plates.
- 2) When total thickness of friction and separate plate falls short of the value in the chart below.

### 3. PERIODIC MAINTENANCE

Standard dimensions		
Separate plate	4 plates:	2.3 (per plate)
Friction plate	3 plates:	3.3 (per plate)
Total thickness		19.1
Standard total thickness for replacement		
		18.5

Thickness of separate and friction plates for SW880 and SW990 are the same.

→ Checking procedure: Disassemble and measure the plate thickness in every 500 hours of operation in accordance with the instruction given earlier.

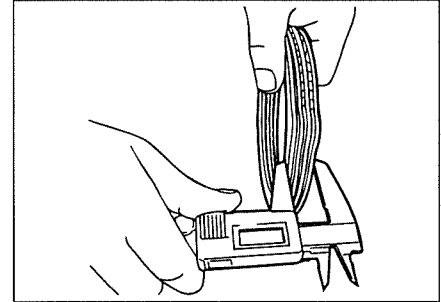

#### ⑬ Suction filter

Take off the hydraulic tank cover. Take out and clean the strainer, change the strainer if necessary.

#### ⑳ Vibrator

- 1) Rotate the drum till the drain plug comes to bottom.
- 2) Remove the drain and level plugs.
- 3) Drain the vibrator oil.
- 4) Rotate the roll until the mark on its inside comes to the bottom.
- 5) Feed oil from top filler port until oil overflows out of level gauge port.
- 6) After cleaning, reinstall level gauge plug and filler ports plug.

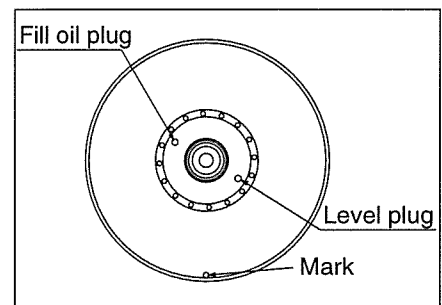

(6) As required

① Water tank

- 1) With the drain cap removed, remove the water and sediment from the bottom of the tank.
- 2) If sedimentation is substantial, remove the drain plug and clean the interior of the tank.
- 3) When the necessary work is complete, refit the drain cap and filler cap.

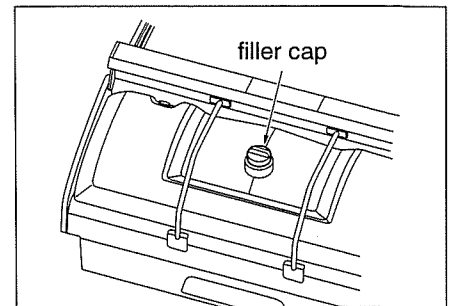
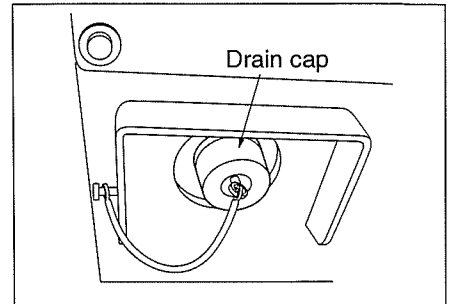
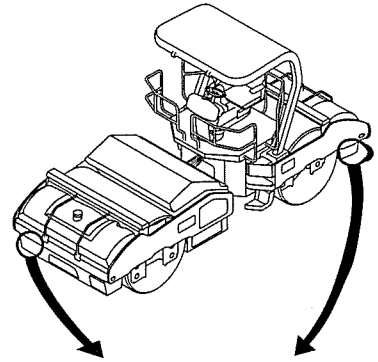

⑧ Fuel tank

- 1) With the drain plug removed, remove the water and sediment from the bottom of the tank.
- 2) If sedimentation is substantial, remove the drain plug and clean the interior of the tank.
- 3) When the necessary work and refueling are complete, tighten the filler cap positively.

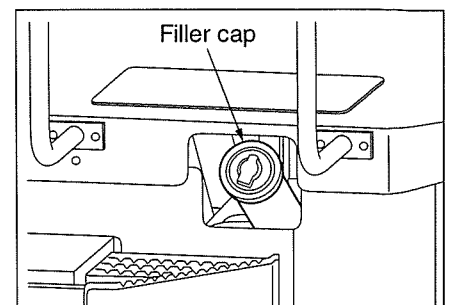
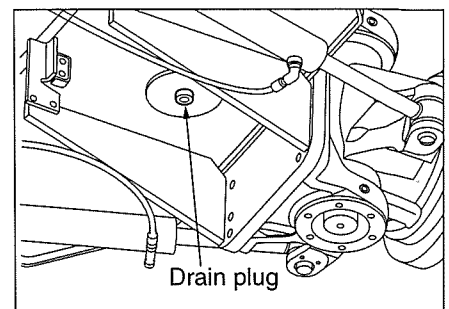

### 3. PERIODIC MAINTENANCE

NOTE: When removing the water and sediment from the tank filled with the fuel, the fuel will gush out if the drain plug is screwed out completely.

#### **⚠ WARNING**

- The fuel will catch fire if open flames or ignition sources are used close to it.
- Do not smoke or use a match or cigarette lighter close to it.



#### ⑩ Air cleaner

Clean the element as described below:

- 1) Take off clips and then the cover, and pull out element.
- 2) Blow compressed air from inside of the element to clean.

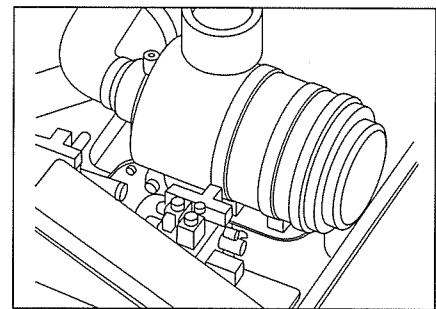

#### **⚠ WARNING**

Exercise caution not to get dust blown in your eyes.

- 3) Check the element to see if there is any damage or not. If there is any damage replace element.
- 4) Assembly the element and cover.

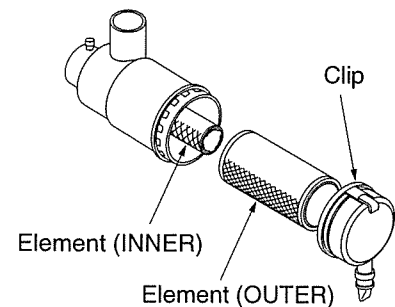

NOTE: Replace the element once in every sixth cleaning.

#### **⚠ CAUTION**

When the air cleaner is clogged with in dust, the engine check lamp will come on.



**19 Scraper**

When the blade is worn, adjust the scraper properly.

See page 33 for adjustment. If the clearance is beyond the adjustable range, change the blade.

**⚠ WARNING**

**Be careful not to pinch your fingers between the drum and blade.**

**3.5 Fluid and Lubricant Capacities****1 General rules**

- 1) Never fill with water or lubricants with the strainer removed.
- 2) Use recommended lubricant and hydraulic fluid.
- 3) Do not use lubricants and hydraulic fluid of different brands.
- 4) When replacing oil, drain it completely and clean the container with flushing oil before filling with new oil.
- 5) Be sure to use fuels and greases designated / recommended by SAKAI. Faulty due to the use of those not designated/recommended by SAKAI is out of the scope of repair and guarantee.

**2 Capacity**

Compartment	Type of fluid	Capacity in liters (gal.)	
		SW880	SW990
Engine oil pan	Engine oil	11 l (2.9)	15.5 l (4.1)
Front drum motor	Gear oil	3.6 l (0.95)	3.6 l (0.95)
Rear drum motor	Gear oil	3.6 l (0.95)	3.6 l (0.95)
Vibrator	Gear oil	22 l × 2 (5.8 × 2)	22 l × 2 (5.8 × 2)
Hydraulic tank	Hydraulic oil	55 l (15)	55 l (15)
Fuel tank	Diesel fuel	315 l (83)	315 l (83)
Radiator	Coolant	17 l (4.5)	19 l (5.0)
Sprinkler tank	Water	600 l × 2 (159 × 2)	600 l × 2 (159 × 2)

### 3. PERIODIC MAINTENANCE

#### 3 Rating

Lubricant	Service classification	Ambient temp. and applicable viscosity rating			Applicable standards
		-15 ~ 30°C (5 ~ 86°F) Cold	0 ~ 40°C (32 ~ 104°F) Moderate	15 ~ 55°C (59 ~ 131°F) Tropical	
Engine oil	API grade CH-4	SAE 10W-30	SAE 30	SAE 40	MIL-L-2104D
Gear oil	API grade GL4	SAE 80W-90	SAE 90	SAE 140	MIL-L-2105
Hydraulic oil	Wear resistant	ISO-VG32 over VI 140	ISO-VG46 over VI 140	ISO-VG68 over VI 110	ISO-3448
Grease	Lithium type extreme pressure				NLGI-2
Fuel	Diesel fuel				ASTM D975-2D

#### 4 Recommended lubricants

Lubricant Oil company	Engine oil API CH – 4	Gear oil API GL – 4	Hydraulic oil VG 46	Grease (NLGI – 2)
CALTEX	DELO 400 oil	Universal Thuban 90	Rando Oil HD 46	Martifack EP 2
BP	BP Vanellus MG	BP Gear Oil EP 90	BP Energol HLP 46	BP Energrease LP – EP 2
ESSO	Esso Lube XD – 3 extra	Esso Gear Oil GP 90	Nuto H 46	Beacon EP 2
MOBIL	Mobil Delvac 1300 super	Mobil Pegasus Gear Oil 90	Mobil DTE 25	Mobilux EP 2
SHELL	Shell Rotella T	Shell Spirax 90 EP	Shell Tellus Oil T46	Shell Alvania EP Grease 2

### 3.6 Electric Wiring Diagram

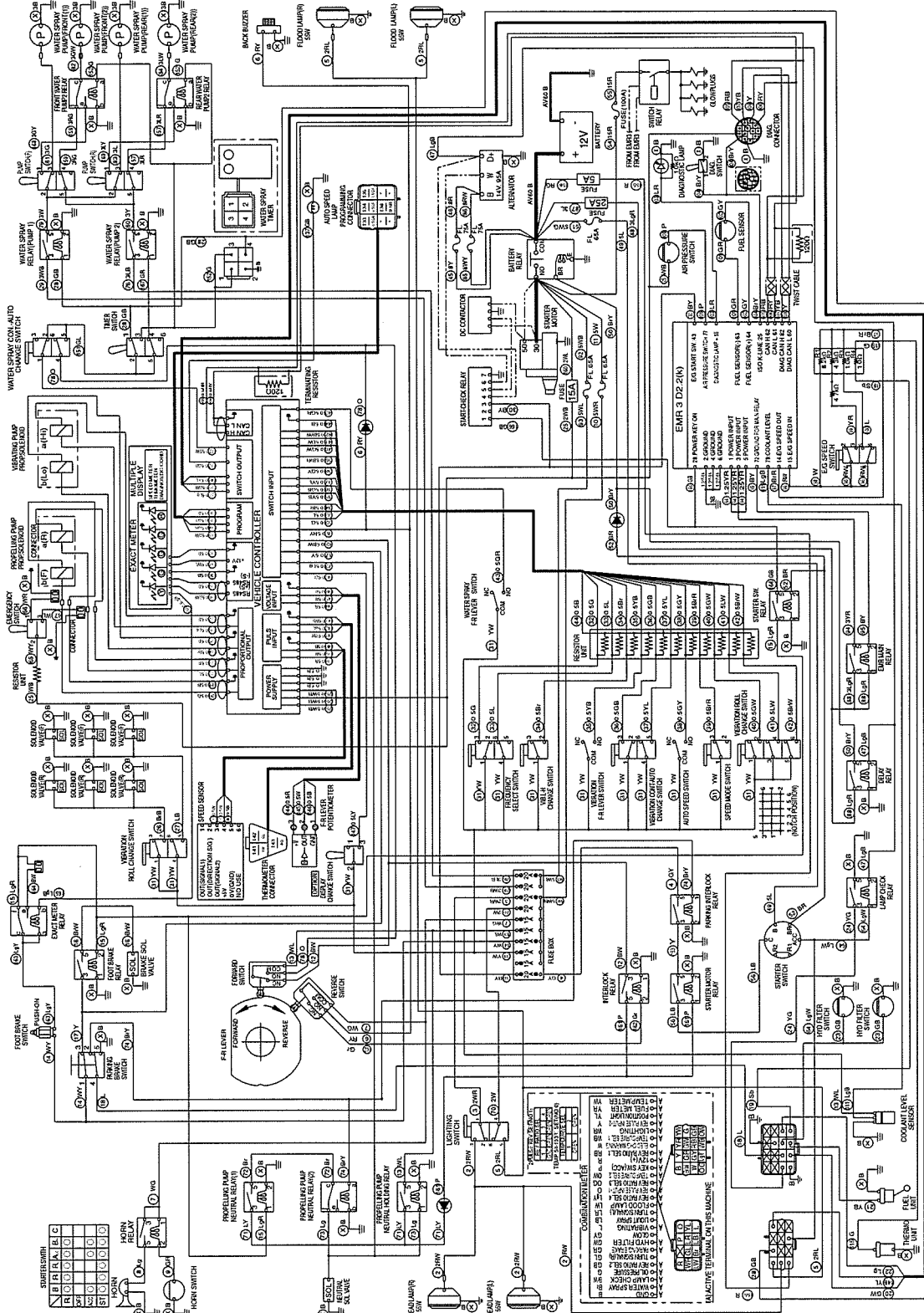

CAUTION: Size of wires not indicated by letters are AVS 0.85.

Color of wire	B	BR	BRW	GR	GRN/Red stripe	LR	Blue/Red stripe	P	Pink	RW	Red/White stripe	WR	White/Red stripe	YR	Yellow/Red stripe	LB	Blue/Black stripe
	Black	Black/Red stripe	Brown/White stripe	Green/White stripe	Green/White stripe	LW	Blue/White stripe	R	Red	RY	Red/Yellow stripe	Y	Yellow	YW	Yellow/White stripe	WG	White/Green stripe
	Black/White stripe	Green	Green/Black stripe	Green/Yellow stripe	Green/Yellow stripe	LY	Blue/Yellow stripe	RB	Red/Black stripe	W	White	YB	Yellow/Black stripe	BRY	Brown/Yellow stripe		
	Black/Yellow stripe	Green/Black stripe	Gray	Gray	Light green	Lg	Light green	RG	Red/Green stripe	WB	White/Black stripe	YG	Yellow/Green stripe	Sb	Blue		
	Brown	Green/Blue stripe	L	Blue	O	Orange	RL	Red/Blue stripe	WL	White/Blue stripe	YL	Yellow/Blue stripe	BG	Black/Green stripe			

### 3. PERIODIC MAINTENANCE

#### Fuse box

The fuse box houses five 15A- and five 20A- fuses lined up with spares fitted for 15A- and 20A- fuses. Use fuses of correct capacity. See page 32.

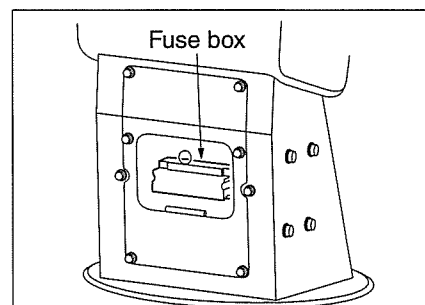

#### Line fuse

The line fuse holders 5A, 15A, 25A, are located on the front of the battery. Use fuses of correct capacity. See page 32.

NOTE: When a fuse is burned, determine the cause before replacing.

#### Battery

- 1) Leaving the battery unused for long periods of time without attention or draining it completely down can cause damage to the plates, leading to a shortened life.
- 2) For long-term storage, charge it fully, tighten the caps securely, store in a cool and dry place, and check the level of charge at least once a month.
- 3) Maintain the level of charge above 75%.
- 4) In cold weather, it is desirable to start the engine with the battery charged 100%. Do not try to start the engine with less than 75%.

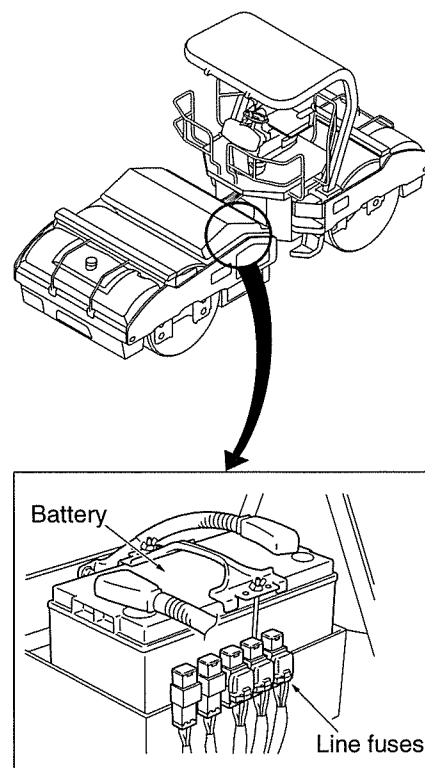

## 4 SPECIFICATIONS

### (1) SW880

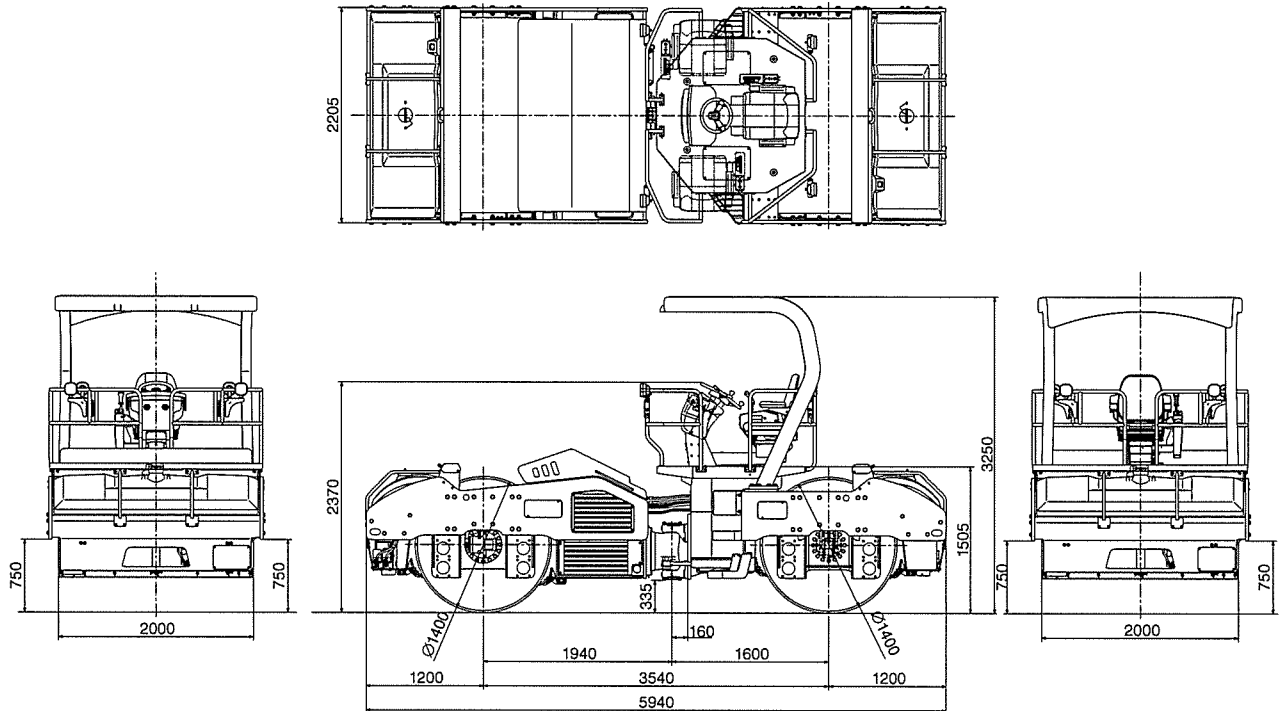

Model	SW880		
<b>Weight</b>			
Gross weight	13,410 kg (29,560 lbs)		
Empty weight	12,210 kg (26,920 lbs)		
<b>Dimension</b>			
Overall length	5,940 mm (234")		
Overall width	2,205 mm ( 87")		
Overall height			
Steering wheel	2,370 mm ( 93")		
ROPS	3,250 mm (128")		
Wheelbase	3,540 mm (139")		
Wheel			
Front	Roll (dia. x width) 1,400 x 2,000 mm (55" x 79")		
Rear	Roll (dia. x width) 1,400 x 2,000 mm (55" x 79")		
<b>Performance</b>			
Travel speed (forward/reverse)	0 ~ 11 km / h (0 ~ 6.8 mile / h)		
<b>Vibrating power</b>			
Gradability	29 % (16.5°)		
Rolling width	2,000 mm (79")		
Minimum turning radius	6.4 m (252")		
<b>Vibrating power</b>			
Low amplitude			
Frequency	67 Hz (4,000 vpm)	50 Hz {3,000 vpm}	42 Hz {2,500 vpm}
Centrifugal force	160 kN (35,970 lbs)	90 kN (20,235 lbs)	63 kN (14,165 lbs)
High amplitude			
Frequency	50 Hz {3,000 vpm}		42 Hz {2,500 vpm}
Centrifugal force	177 kN (39,790 lbs)		123 kN (27,650 lbs)
<b>Engine</b>			
Model	DEUTZ *TCD2012L04 2V" Diesel Engine (EPA Tire3) (with turbo charger)		
Total displacement	4.038 l (246 cu.in)		
Rated output	98 kW / 2,400 min <sup>-1</sup> {rpm} (131 HP / 2,400 rpm)		
Max. torque	495 N·m / 1,600 min <sup>-1</sup> {rpm} (365 ft-lb / 1,600 rpm)		
<b>Tank capacity</b>			
Fuel tank	315 liters (83 gal)		
Hydraulic tank	55 liters (15 gal)		
Sprinkler tank	600 liters x 2 (159 gal x 2)		

**NOTE:** Gradability is the calculated value. It may vary with ground surface conditions.

## 4. SPECIFICATIONS

### (2) SW990

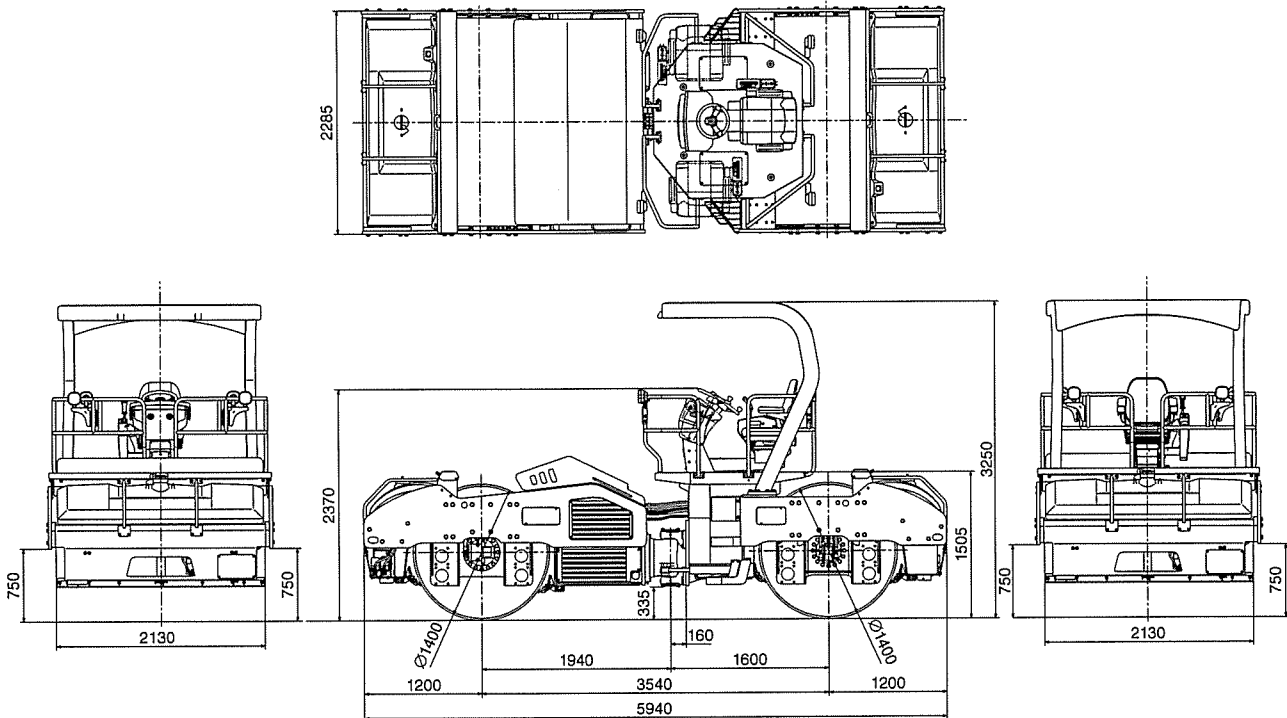

<b>Model</b>	<b>SW990</b>
<b>Weight</b>	
Gross weight	13,970 kg (30,800 lbs)
Empty weight	12,770 kg (28,150 lbs)
<b>Dimension</b>	
Overall length	5,940 mm (234")
Overall width	2,285 mm ( 90")
Overall height	
Steering wheel	2,370 mm ( 93")
ROPS	3,250 mm (128")
Wheelbase	3,540 mm (139")
<b>Wheel</b>	
Front	Roll (dia. x width) 1,400 x 2,130 mm (55" x 84")
Rear	Roll (dia. x width) 1,400 x 2,130 mm (55" x 84")
<b>Performance</b>	
Travel speed (forward/reverse)	0 ~ 11 km / h (0 ~ 6.8 mile / h)
<b>Vibrating power</b>	
Gradability	28 % (15.5°)
Rolling width	2,130 mm (84")
Minimum turning radius	6.5 m (256")

<b>Vibrating power</b>			
Low amplitude			
Frequency	67 Hz {4,000 vpm}	50 Hz {3,000 vpm}	42 Hz {2,500 vpm}
Centrifugal force	173 kN (38,890 lbs)	98 kN (22,030 lbs)	68 kN (15,285 lbs)
High amplitude			
Frequency	50 Hz {3,000 vpm}	42 Hz {2,500 vpm}	
Centrifugal force	185 kN (41,590 lbs)	128 kN (28,775 lbs)	
<b>Engine</b>			
Model	DEUTZ *TCD2012L06 2V* Diesel Engine(EPA Tire3) (with turbo charger)		
Total displacement	6.067 ℓ (370 cu.in)		
Rated output	124 kW / 2,400 min <sup>-1</sup> {rpm} (166HP / 2,400 rpm)		
Max. torque	680 N·m / 1,600 min <sup>-1</sup> {rpm} (502 ft·lb / 1,600 rpm)		
<b>Tank capacity</b>			
Fuel tank	315 liters (83 gal)		
Hydraulic tank	55 liters (15 gal)		
Sprinkler tank	600 liters x 2 (159 gal x 2)		

**NOTE:** Gradability is the calculated value. It may vary with ground surface conditions.

**SAKAI HEAVY INDUSTRIES, LTD.**

Head Office: 1-4-8, Shiba Daimon, Minato-ku,  
Tokyo, Japan

Telephone: Tokyo (03) 3431-9971

Facsimile: (03) 3436-6212