

PREFACE

Generally, rollers tend to come large-sized and find their applications in dangerous fields such as rough terrain, steep slopes or slippery areas. Faulty rollers may risk a grave accident.

For purpose-built rollers to negotiate problem terrain with the ultimate in performance maintained free from failure over the longest possible period of time, adequate handling and regular preventive maintenance recommended are of prime importance. If a trouble develops, it should be effectively corrected with proper safety measures taken.

This service manual is intended to serve as a guide particularly for maintenance personnel to perform quality service by gaining working knowledge of and reliable maintenance techniques for machines in question.

Included in this literature are descriptions of SPECIFICATIONS, STRUCTURE & OPERATION, INSPECTION & ADJUSTMENT, FAULT DIAGNOSIS and DISASSEMBLY & ASSEMBLY. Systematic explanations are being given to each of these five categories in this sequence.

Rollers principally concern qualitative factors as represented by 'compaction density', to say nothing of quantitative elements like 'productivity'. SPECIFICATIONS section includes performance data of major significance e.g. 'vibratory frequency' to be checked when servicing machines in question.

For reasonable maintenance services, it is a precondition to know the vital portions of machines in question and how they work. Referring to relevant electric wiring and hydraulic circuit diagrams, STRUCTURE & OPERATION instructs location of key units and function of systems into which the key units are assembled.

Adjustment practice to restore a faulty machine to the normal operating state involves measurement procedure which compares measured figures with the standard values. INSPECTION & ADJUSTMENT specifies conditions to measurement and standard values. Safety precautions are also given where necessary. Illustrations included indicate important points like gauge connection location.

Numerous ways are available to track down the cause of trouble. Important is, of course, to make a diagnosis in a reasonable manner, not blindly. FAULT DIAGNOSIS provides a detailed description of 'Precautions for Trouble Diagnosis' and 'How to Make a Diagnosis' first, then proceeds to instruction of diagnosis procedures on a variety of fault diagnosis modes. For effective fault finding, this chapter employs block-type flow charts easy to handle. Electric wiring diagrams used herein identify wires by means of color coding and identification numbers. Standard values or fault finding conditions are noted where necessary.

In the final section, DISASSEMBLY & ASSEMBLY, descriptions are being given of removal, reinstallation, disassembly and reassembly procedures of key units in this order with many solid illustrations easy to understand in order to display vital part of units to handle. Because works to be performed in this category will inevitably have a high potential to invite danger, this section involves many precautionary statements.

Fully understand the contents of this manual and make the best of it. We will make utmost efforts to make this manual more useful through revisions. Your opinions and advices will be particularly welcome and carefully considered.

CONTENTS

SPECIFICATIONS	1-001
STRUCTURE AND OPERATION	2-001
INSPECTION AND ADJUSTMENT	3-001
FAULT DIAGNOSIS	4-001
DISASSEMBLY AND ASSEMBLY	5-001

SPECIFICATIONS

SPECIFICATIONS

1. External Views and Specification Data

1-1. SW352	1-002
1-2. TW352	1-003
1-3. SW502	1-004
1-4. TW502	1-005

1.External Views and Specification Data

1-1. SW352

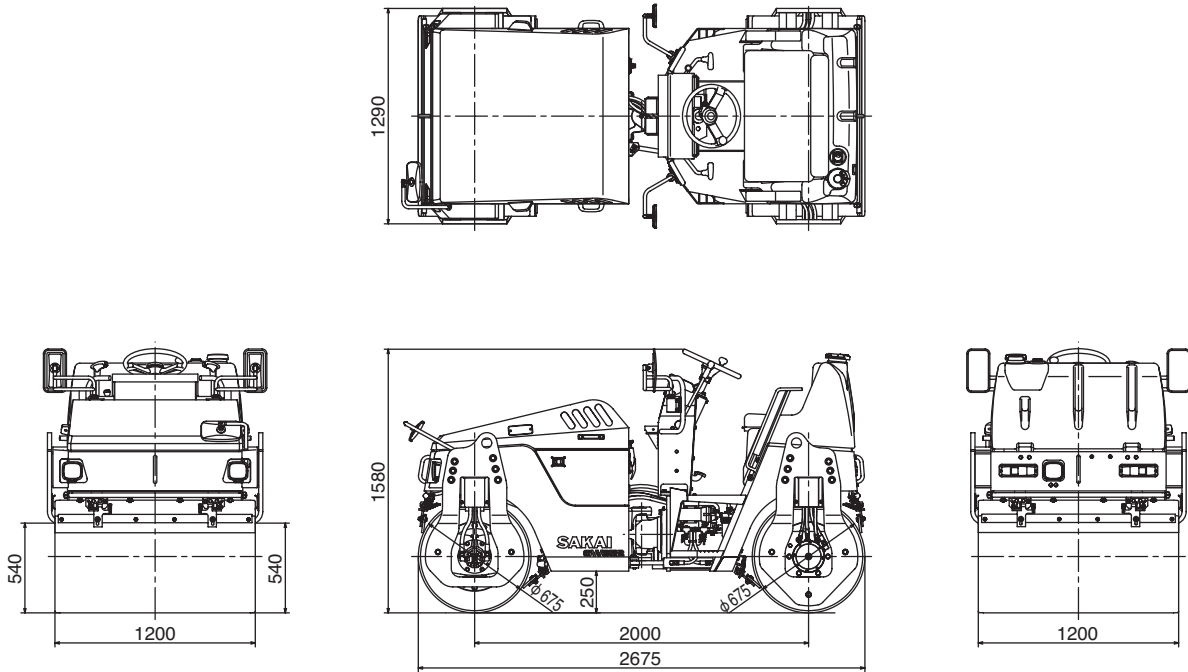

TW5021001

Model		SW352	
Weight:			
Gross weight	2,940 kg (6,485 lbs)		
Empty weight	2,740 kg (6,045 lbs)		
Dimension:			
Overall length	2,675 mm (105")		
Overall width	1,290 mm (51")		
Overall height	1,580 mm (62")		
Wheelbase	2,000 mm (79")		
Wheel			
Front	Roll (dia. x width)		
	675 x 1,200 mm (27" x 47")		
Rear	Roll (dia. x width)		
	675 x 1,200 mm (27" x 47")		
Performance:			
Travel speed			
(forward/reverse)			
Low	0 ~ 9 km/h (0 ~ 5.6 mile/h)		
High	0 ~ 12 km/h (0 ~ 7.5 mile/h)		
Vibrating power:			
Frequency	55 Hz		
Centrifugal force	20.6 kN (4,630 lbs)		
Gradability	21 degrees		
Rolling width	1,200 mm (47")		
Minimum turning radius	3.8 m (150")		
Engine:			
Model	KUBOTA "D1503-KA" Diesel Engine		
Total displacement	1.499 liters (91 cu.in)		
Rated output	20.1 kW/2,300 min ⁻¹ (27 HP/2,300 min ⁻¹)		
Max. torque	97 N·m/1,500 min ⁻¹ (72 ft-lb/1,500 rpm)		
Tank capacity:			
Fuel tank	40 liters (10.6 gal)		
Hydraulic tank	43 liters (11.4 gal)		
Sprinkler tank	200 liters (53 gal)		

NOTE: Gradability is the calculated value. It may vary with ground surface conditions.

1-2. TW352

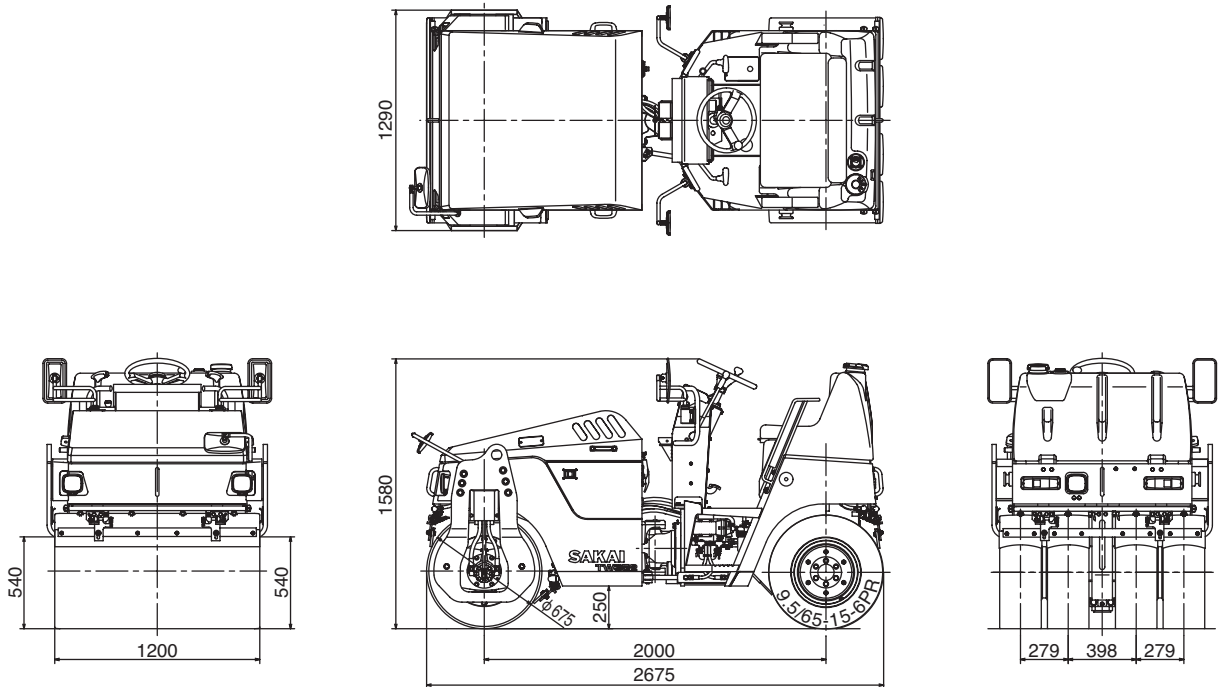

TW5021002

Model		TW352	
Weight:			
Gross weight		2,640 kg (5,820 lbs)	
Empty weight		2,440 kg (5,380 lbs)	
Dimension:			
Overall length		2,675 mm (105")	
Overall width		1,290 mm (51")	
Overall height		1,580 mm (62")	
Wheelbase		2,000 mm (79")	
Wheel			
Front		Roll (dia. x width)	
		675 x 1,200 mm (27" x 47")	
Rear		Tire	
		9.5/65-15-6PR	
Performance:			
Travel speed			
(forward/reverse)			
Low		0 ~ 9 km/h (0 ~ 5.6 mile/h)	
High		0 ~ 12 km/h (0 ~ 7.5 mile/h)	
Vibrating power:			
Frequency		55 Hz	
Centrifugal force		20.6 kN (4,630 lbs)	
Gradability		21 degrees	
Rolling width		1,200 mm (47")	
Minimum turning radius		3.8 m (150")	
Engine:			
Model		KUBOTA "D1503-KA" Diesel Engine	
Total displacement		1.499 liters (91 cu.in)	
Rated output		20.1 kW/2,300 min ⁻¹ (27 HP/2,300 min ⁻¹)	
Max. torque		97 N·m/1,500 min ⁻¹ (72 ft·lb/1,500 rpm)	
Tank capacity:			
Fuel tank		40 liters (10.6 gal)	
Hydraulic tank		43 liters (11.4 gal)	
Sprinkler tank		200 liters (53 gal)	
Liquid tank		10 liters (2.6 gal)	

NOTE: Gradability is the calculated value. It may vary with ground surface conditions.

SPECIFICATIONS

1-3. SW502

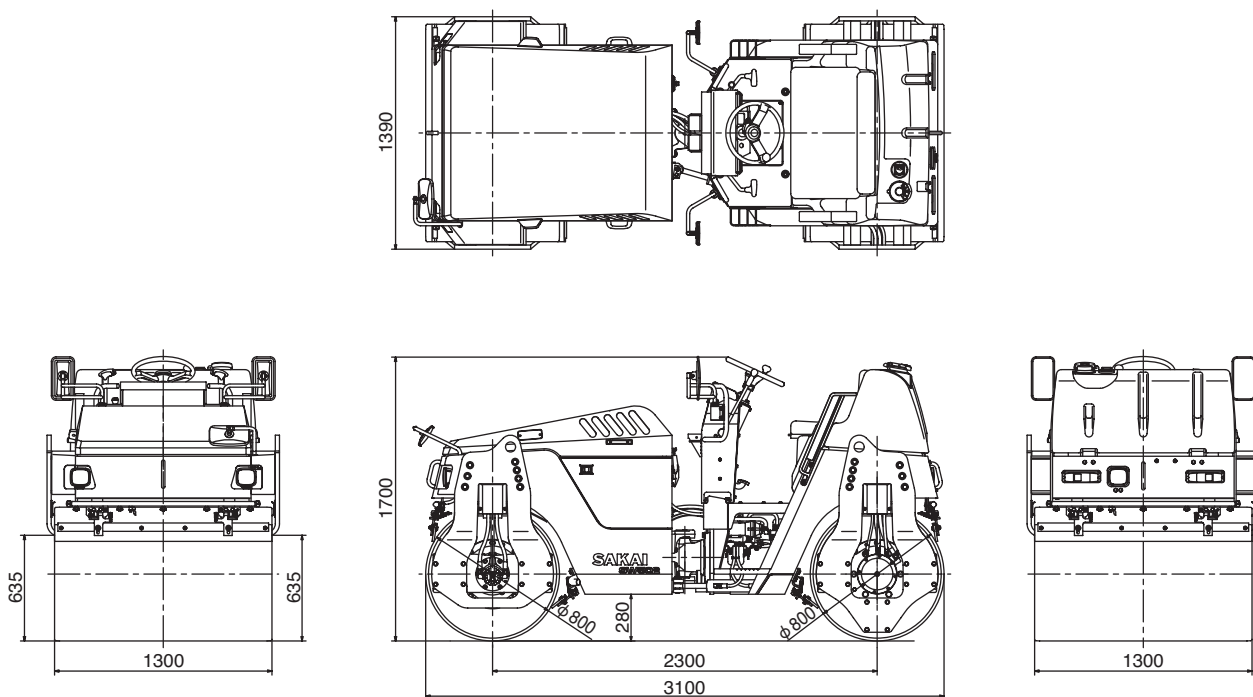

TW5021003

Model	SW502		Vibrating power:	Low	High
Weight:			Frequency	55 Hz	55 Hz
Gross weight	4,090 kg (9,020 lbs)		Centrifugal force	26.5 kN (5,955 lbs)	34.3 kN (7,710 lbs)
Empty weight	3,780 kg (8,335 lbs)		Gradability	21 degrees	
Dimension:			Rolling width	1,300 mm (51")	
Overall length	3,100 mm (122")		Minimum turning radius	4.3 m (169")	
Overall width	1,390 mm (55")		Engine:		
Overall height	1,700 mm (67")		Model	KUBOTA "V2203KA"	
Wheelbase	2,300 mm (91")		Total displacement	2.197 liters (134 cu.in)	
Wheel			Rated output	30.6 kW/2,300 min ⁻¹ (41 HP/2,300 min ⁻¹)	
Front	Roll (dia. x width)		Max. torque	141 N·m/1,600 min ⁻¹ (104 ft-lb/1,600 rpm)	
	800 x 1,300 mm (31" x 51")		Tank capacity:		
Rear	Roll (dia. x width)		Fuel tank	50 liters (13 gal)	
	800 x 1,300 mm (31" x 51")		Hydraulic tank	49 liters (12.9 gal)	
Performance:			Sprinkler tank	310 liters (82 gal)	
Travel speed					
(forward/reverse)					
Low	0 ~ 7.5 km/h (0 ~ 4.7 mile/h)				
High	0 ~ 10.0 km/h (0 ~ 6.2 mile/h)				

NOTE: Gradability is the calculated value. It may vary with ground surface conditions.

1-4. TW502

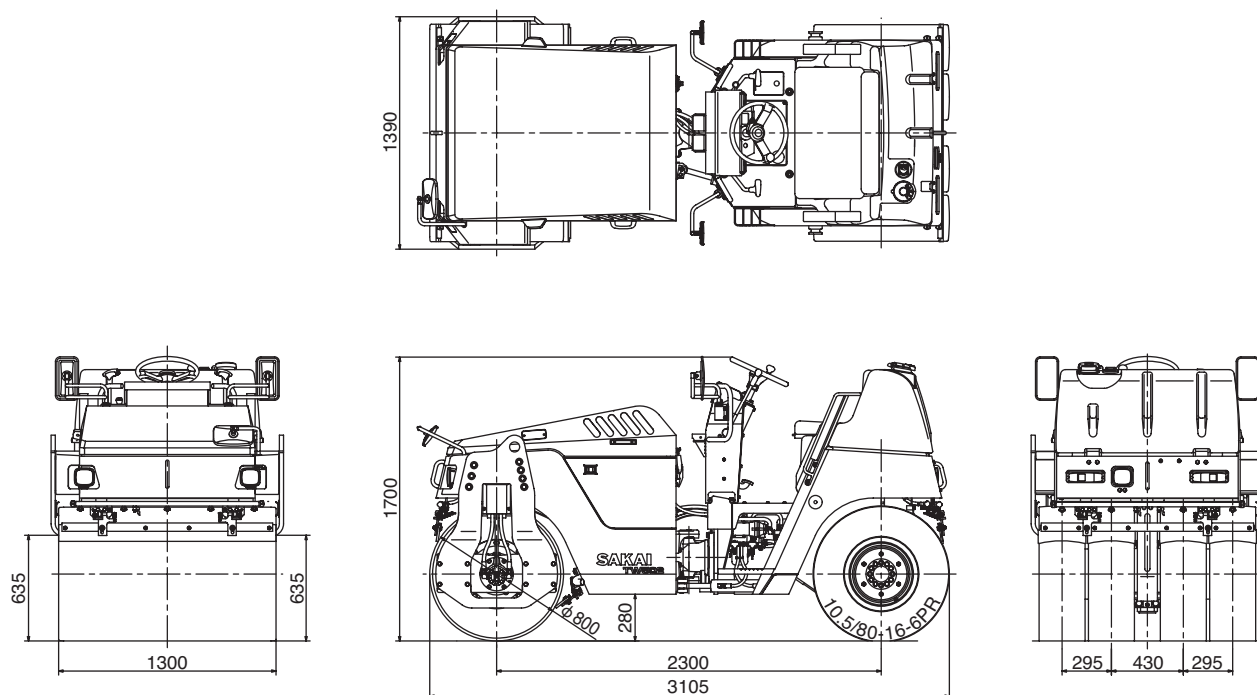

TW5021004

Model		TW502	
Weight:			
Gross weight		3,540 kg (7,800 lbs)	
Empty weight		3,230 kg (7,120 lbs)	
Dimension:			
Overall length		3,105 mm (122")	
Overall width		1,390 mm (55")	
Overall height		1,700 mm (67")	
Wheelbase		2,300 mm (91")	
Wheel			
Front		Roll (dia. x width)	
		800 x 1,300 mm (31" x 51")	
Rear		Tire	
		10.5/80-16-6PR (OR)	
Performance:			
Travel speed		(forward/reverse)	
Low		0 ~ 9.0 km/h (0 ~ 5.6 mile/h)	
High		0 ~ 12.0 km/h (0 ~ 7.5 mile/h)	
Vibrating power:			
		Low	High
Frequency		55 Hz	55 Hz
Centrifugal force		26.5 kN (5,955 lbs)	34.3 kN (7,710 lbs)
Gradability		21 degrees	
Rolling width		1,300 mm (51")	
Minimum turning radius		4.3 m (169")	
Engine:			
Model		KUBOTA "D1503-T-K2A" Diesel Engine (With turbo charger)	
Total displacement		1.499 liters (91 cu.in)	
Rated output		25.7 kW/2,300 min ⁻¹ (34 HP/2,300 min ⁻¹)	
Max. torque		122 N·m/1,600 min ⁻¹ (90 ft·lb/1,600 rpm)	
Tank capacity:			
Fuel tank		50 liters (13 gal)	
Hydraulic tank		49 liters (12.9 gal)	
Sprinkler tank		310 liters (82 gal)	
Liquid tank		10 liters (2.6 gal)	

NOTE: Gradability is the calculated value. It may vary with ground surface conditions.

STRUCTURE AND OPERATION

STRUCTURE AND OPERATION

1. Location of Engine-related Units

1-1. Engine mount	2-003
1-2. Intake system	2-004
1-3. Intake system	2-005
1-4. Exhaust system	2-006
1-5. Exhaust system	2-007
1-6. Cooling piping and radiator	2-008
1-7. Fuel piping and fuel tank	2-009
1-8. Fuel controls	2-010

2. Description and Operation of Hydraulic System

2-1. Hydraulic pump	
2-1-1. Propulsion pump assembly	2-011
2-1-2. Rear vibrator pump assembly (SW352, SW502)	2-012
2-1-3. Front vibrator pump assembly and steering/charge pump assembly	2-013
2-1-4. Hydraulic circuit diagram (SW352)	2-014
2-1-5. Hydraulic circuit diagram (SW502)	2-015
2-1-6. Hydraulic circuit diagram (TW352)	2-016
2-1-7. Hydraulic circuit diagram (TW502)	2-017
2-2. Propulsion line	
2-2-1. Hydraulic piping (front)	2-018
2-2-2. Hydraulic piping (rear)	2-019
2-2-3. Hydraulic piping (rear)	2-020
2-2-4. Propulsion motor (cam motor) assembly (front)	2-021
2-2-5. Propulsion motor (cam motor) assembly (rear)	2-022
2-2-6. Description and operation of cam motor	2-023
2-2-7. Rear axle assembly (TW352, TW502)	2-027
2-2-8. Propulsion controls	2-028
2-2-9. Propulsion circuit diagram (SW352, SW502)	2-029
2-2-10. Propulsion circuit diagram (TW352, TW502)	2-030
2-2-11. Description and operation of propulsion system	2-031
2-3. Vibrating system	
2-3-1. Hydraulic piping (SW352)	2-036
2-3-2. Hydraulic piping (SW502)	2-037
2-3-3. Hydraulic piping (TW352)	2-038
2-3-4. Hydraulic piping (TW502)	2-039
2-3-5. Vibrator motor assembly	2-040
2-3-6. Radiator fan motor assembly	2-041
2-3-7. Vibrator (SW352, TW352)	2-042
2-3-8. Vibrator (SW502, TW502)	2-043
2-3-9. Vibrator circuit diagram (SW352, TW352)	2-044

2-3-10. Vibrator circuit diagram (SW502, TW502)	2-045
2-3-11. Description and operation of vibrating system	2-046
2-4. Steering system	
2-4-1. Hydraulic piping	2-048
2-4-2. Steering valve (Orbitrol)	2-049
2-4-3. Steering cylinder assembly	2-050
2-4-4. Steering circuit diagram	2-051
2-4-5. Description and operation of steering circuit	2-052

3. Brake System

3-1. Brake pedal	2-053
3-2. Description and operation of parking brake (negative brake) circuit	2-054

4. Sprinkler

4-1. Sprinkler piping	2-055
-----------------------------	-------

5. Liquid Sprayer

5-1. Liquid sprayer piping	2-056
----------------------------------	-------

6. Electric System

6-1. Location of instrument panel and key units	2-057
6-2. Location of key units	2-058
6-3. Electric wiring diagram (SW352)	2-059
6-4. Electric wiring diagram (TW352)	2-060
6-5. Electric wiring diagram (SW502)	2-061
6-6. Electric wiring diagram (TW502)	2-062

1. Location of Engine-related Units

1-1. Engine mount

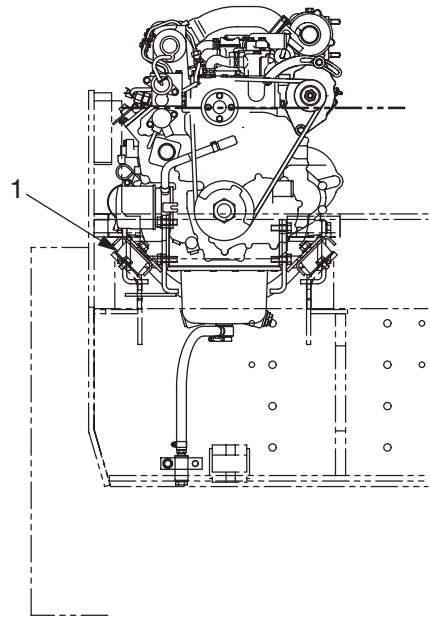
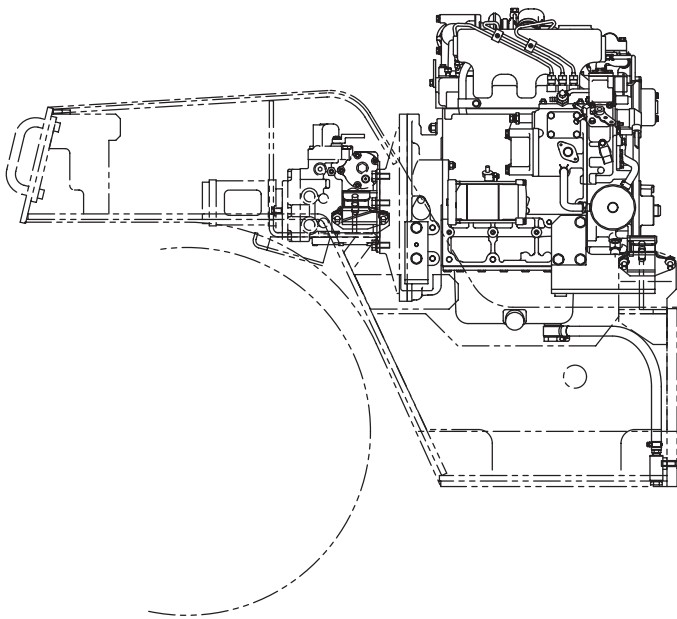
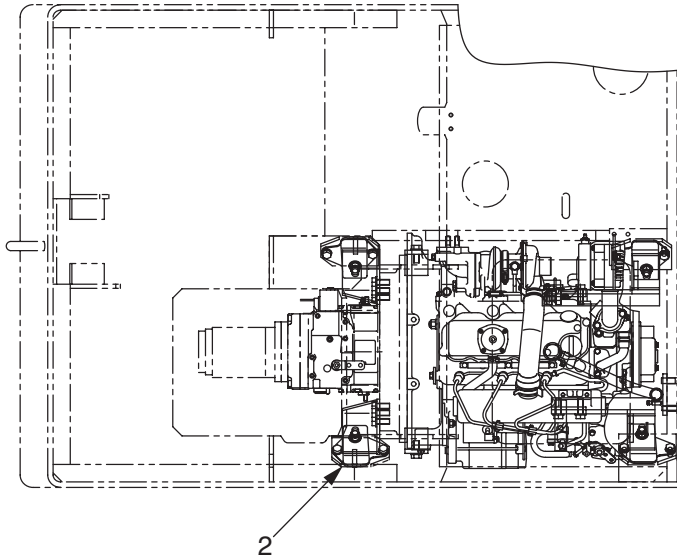

TW5022001

- 1. Engine mount (front)
- 2. Engine mount (rear)

★ Above illustrations show the engine mount of TW502.

1-2. Intake system

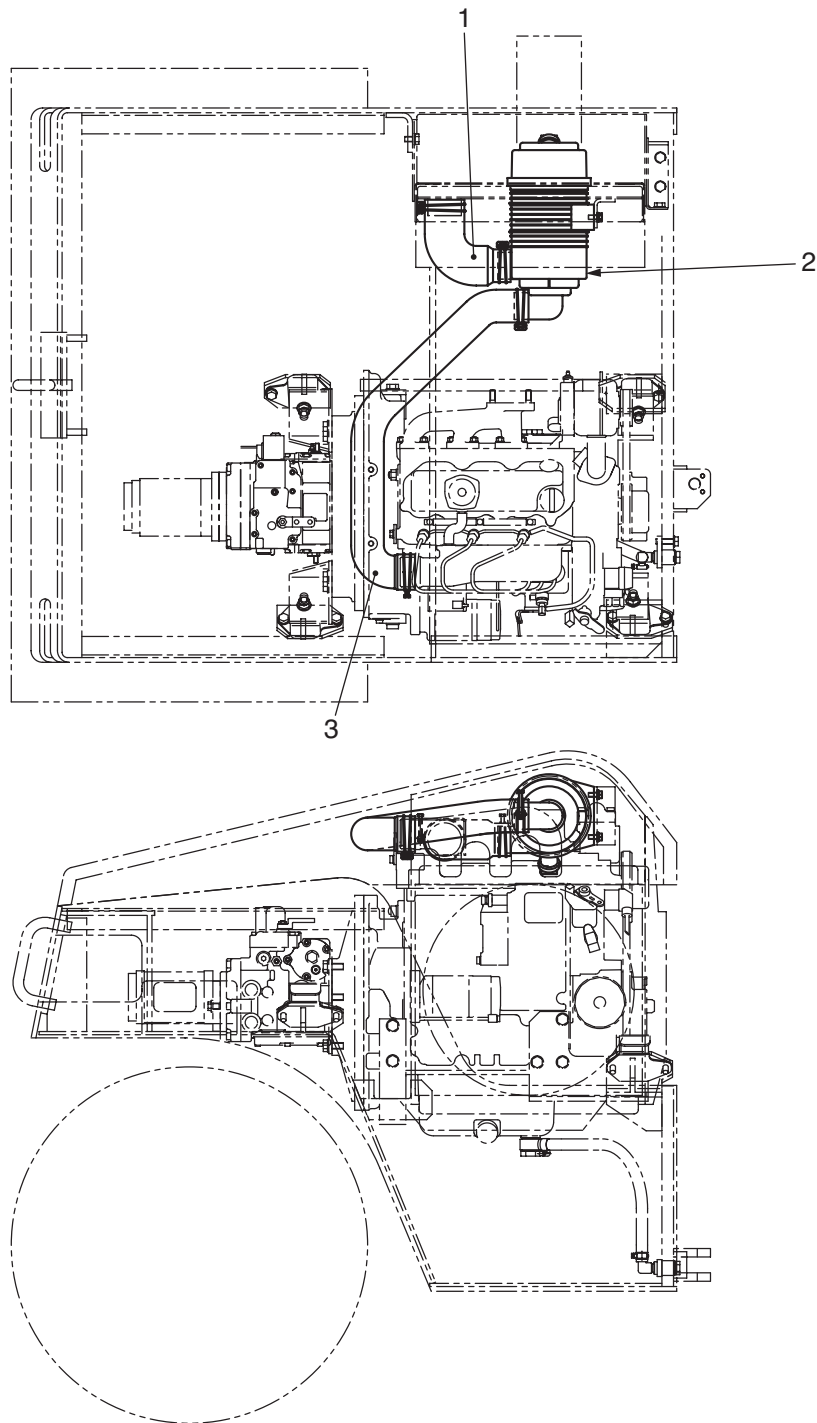

- 1. Intake hose
- 2. Air cleaner
- 3. Intake hose

★ Above illustrations represent the intake items of SW352, TW352.

1-3. Intake system

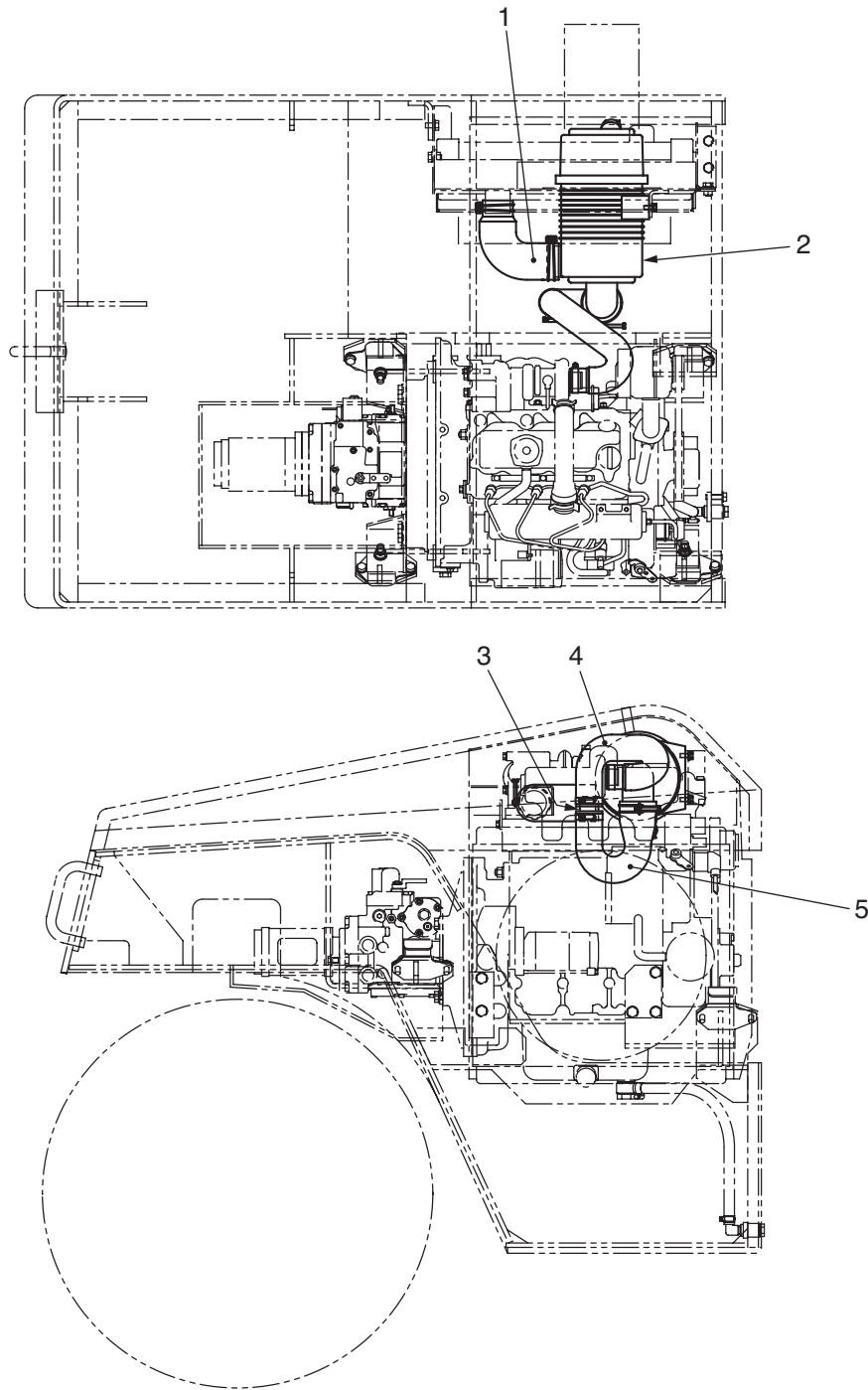

- 1. Intake hose
- 2. Air cleaner
- 3. Intake pipe

- 4. Intake hose
- 5. Intake hose

★ Above illustrations are the intake items of TW502.

TW5022002

1-4. Exhaust system

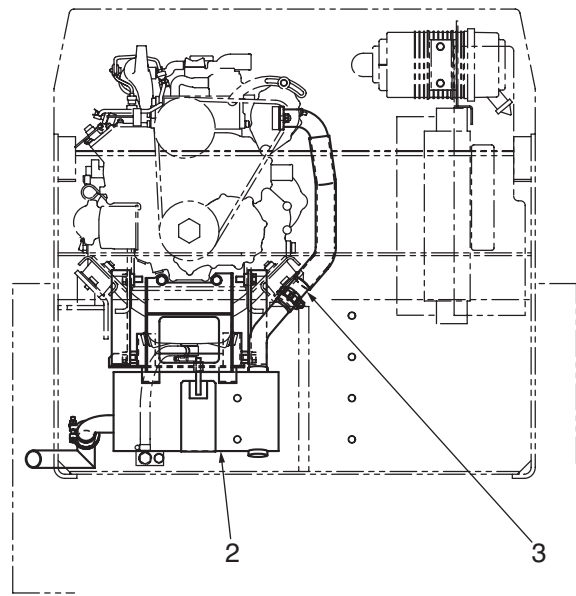
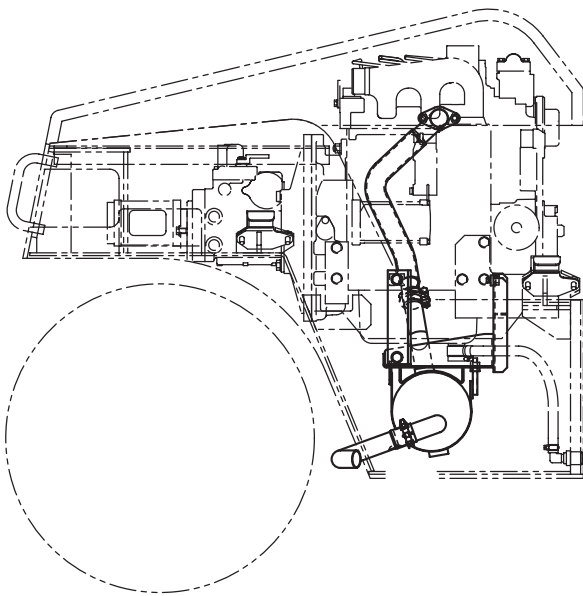
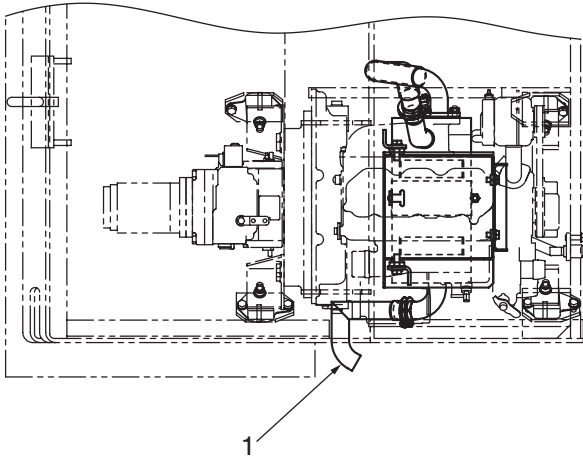

TW5022005

- 1. Exhaust pipe
- 2. Muffler
- 3. Exhaust pipe

★ Above drawings illustrate the exhaust items of SW352, TW352.

1-5. Exhaust system

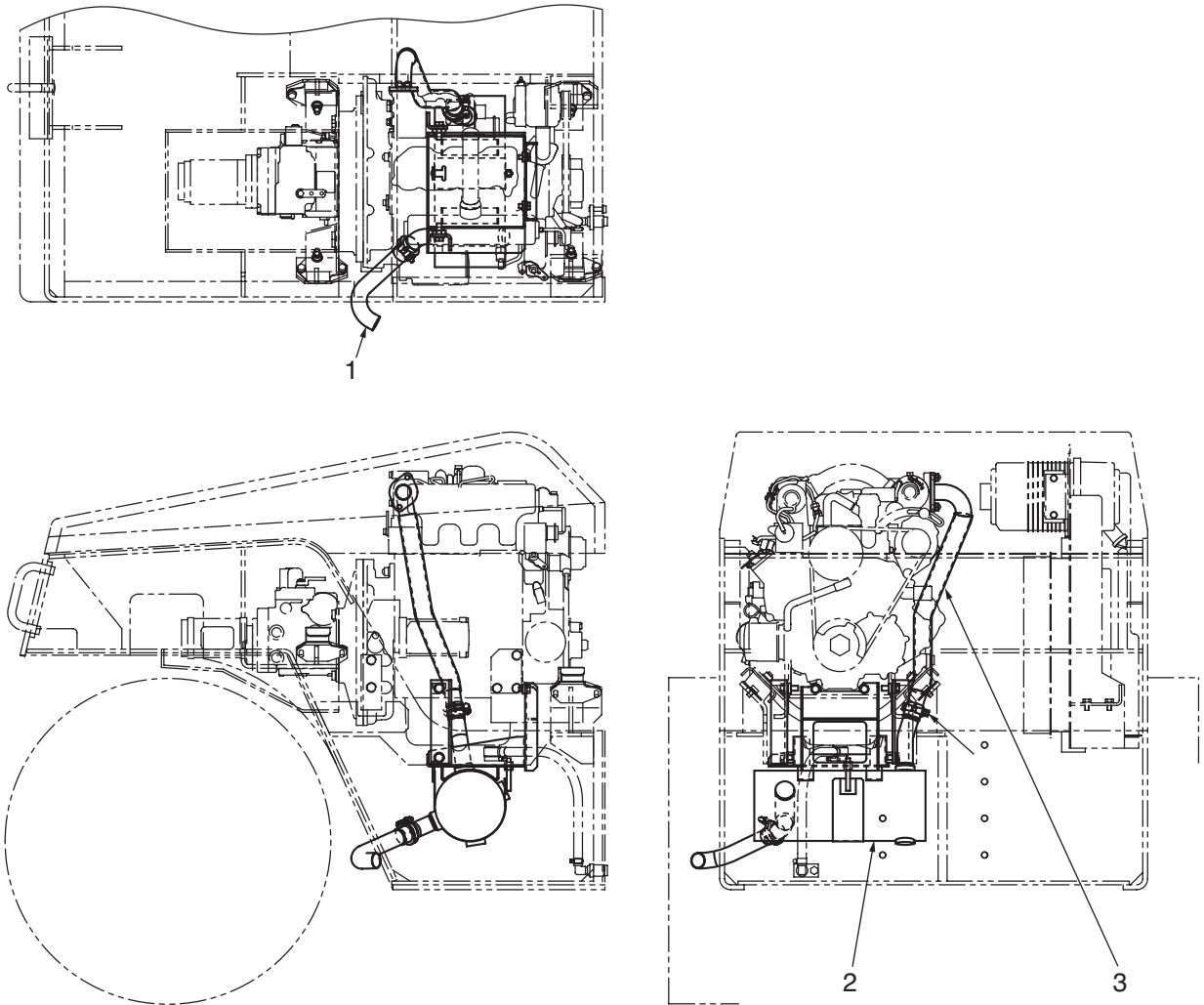

1. Exhaust pipe
2. Muffler
3. Exhaust pipe

TW5022004

★ Above figures represent the exhaust items of TW502.

1-6. Cooling piping and radiator

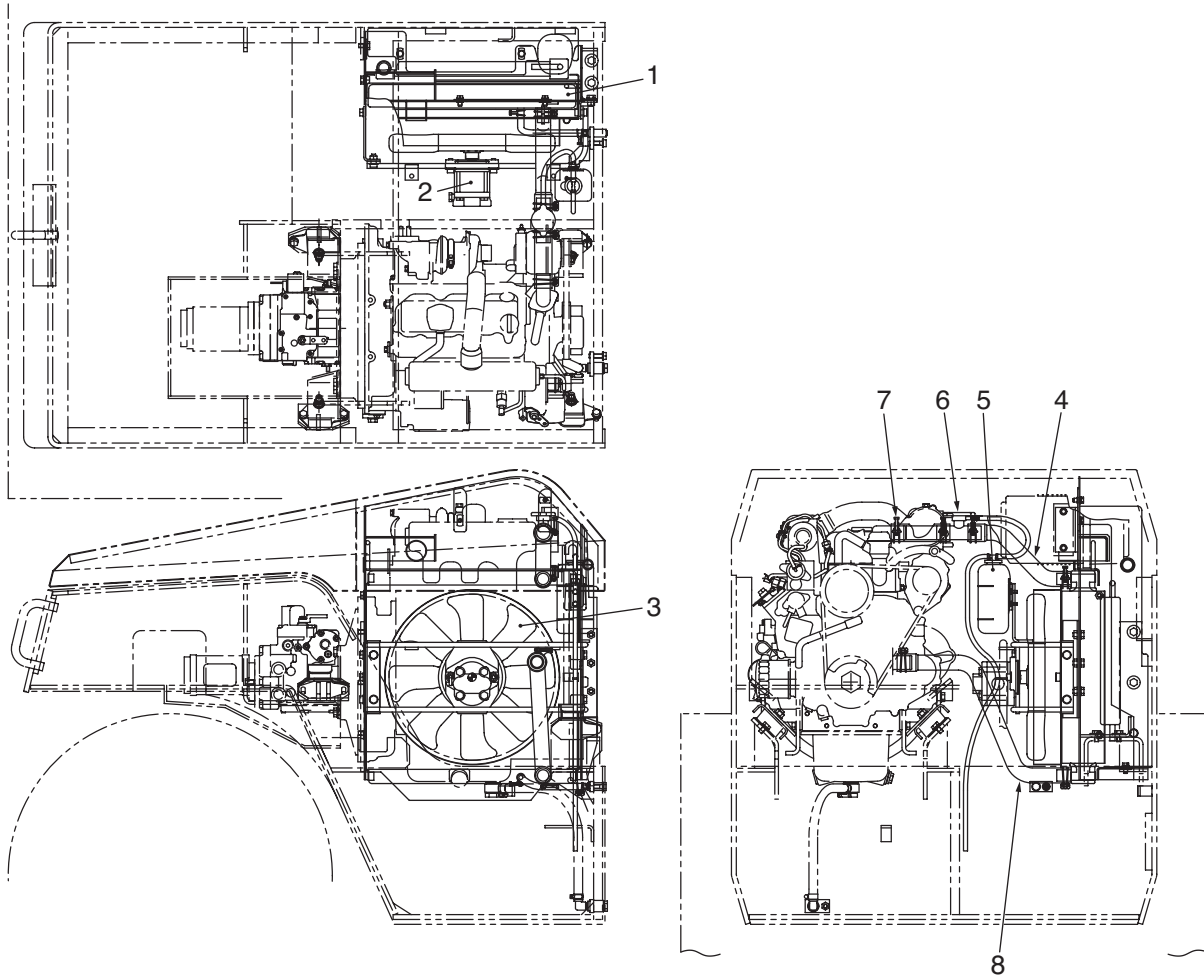

- | | |
|------------------------|-------------------------|
| 1. Radiator | 5. Sub tank |
| 2. Radiator fan motor | 6. Pipe |
| 3. Radiator fan | 7. Hose |
| 4. Radiator inlet hose | 8. Radiator outlet hose |

TW5022057

1-7. Fuel piping and fuel tank

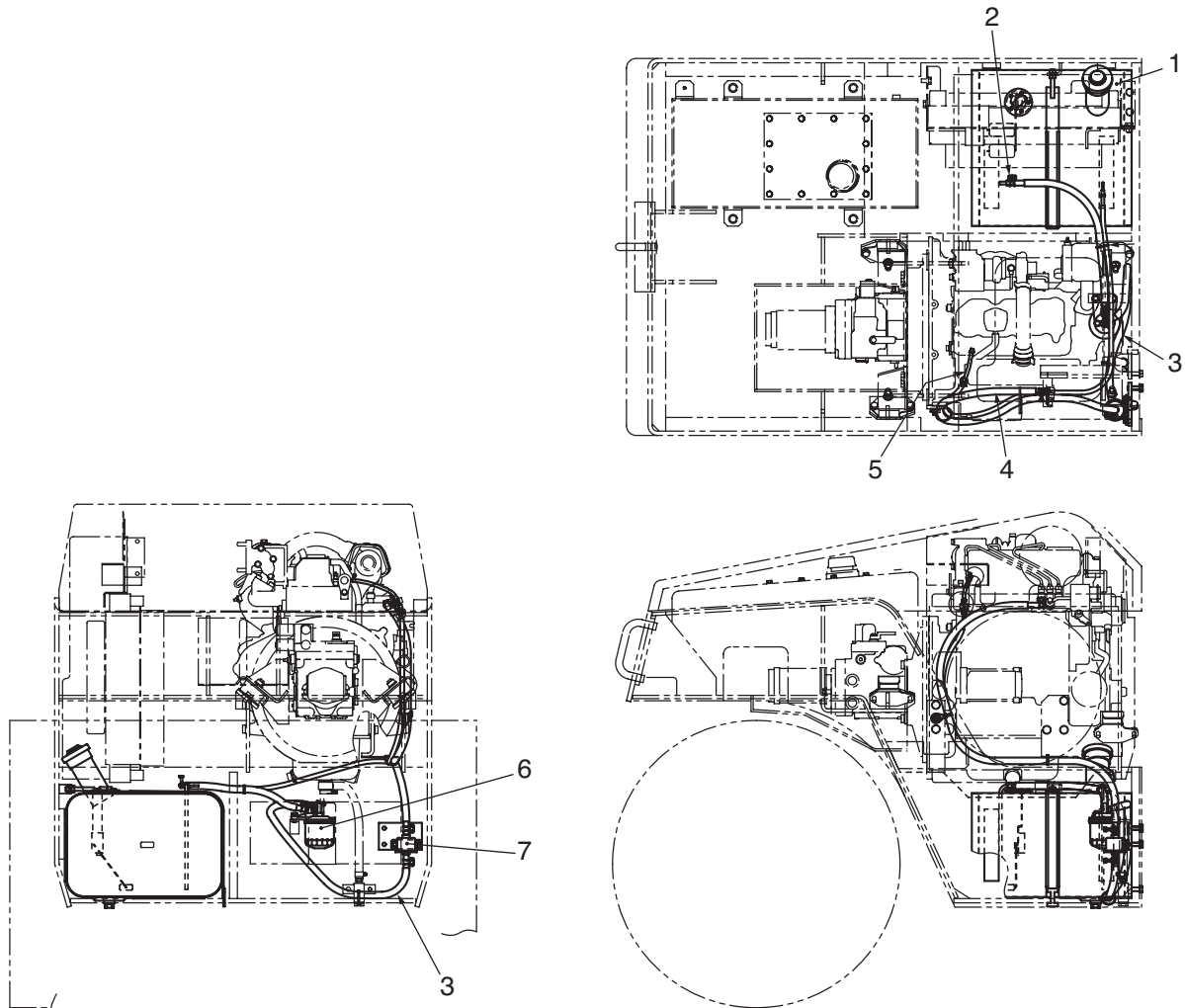

TW5022006

1. Fuel tank
2. Hose (fuel tank to filter)
3. Hose (filter to fuel pump)
4. Hose (fuel pump to injection pump)

5. Hose (injection pump to fuel tank)
6. Fuel filter
7. Fuel pump

1-8. Fuel controls

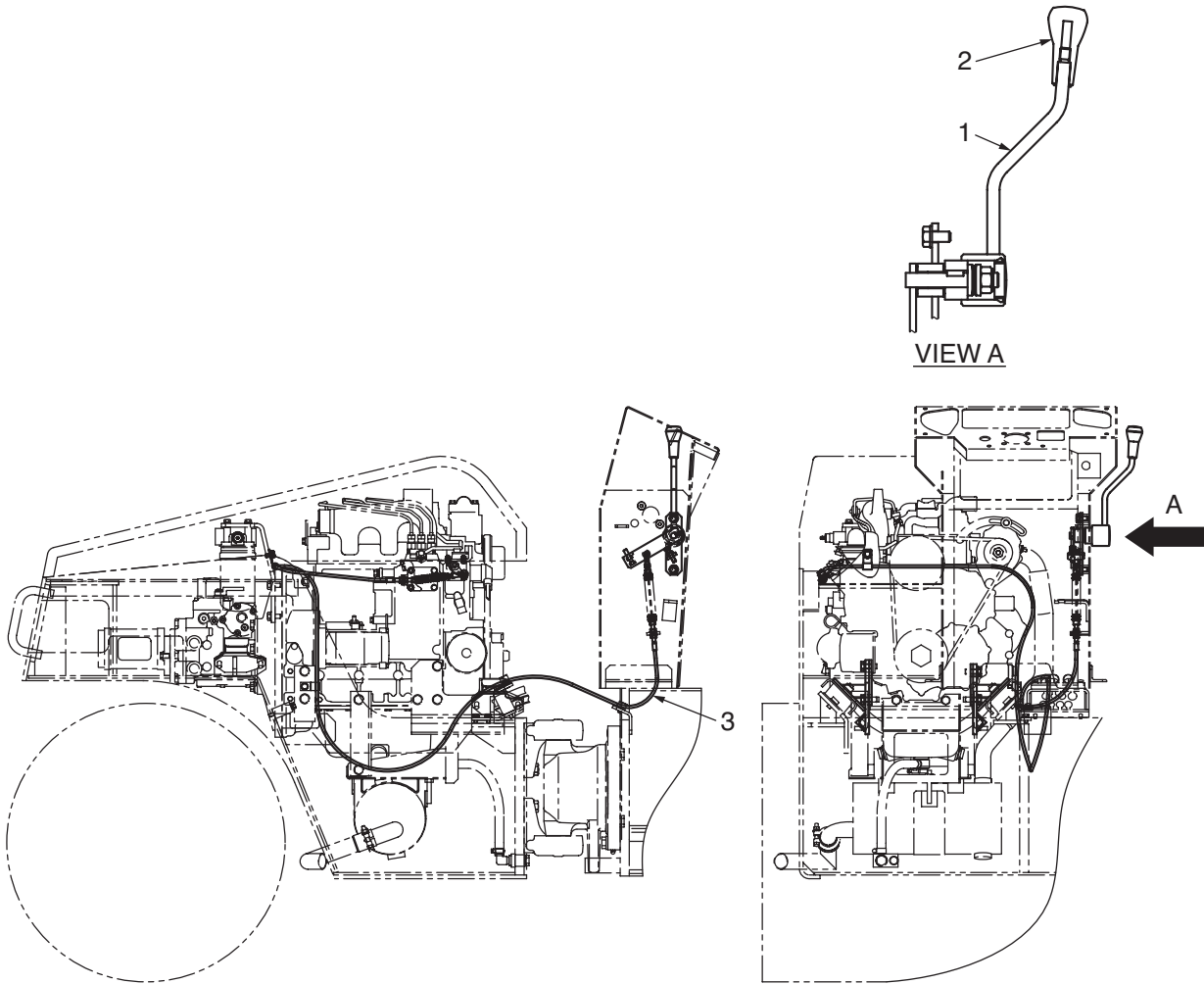

TW5022007

- 1. Throttle lever
- 2. Knob
- 3. Throttle cable

2. Description and Operation of Hydraulic system

2-1. Hydraulic pump

2-1-1. Propulsion pump assembly

★ Both pumps have the same shape but different displacement.

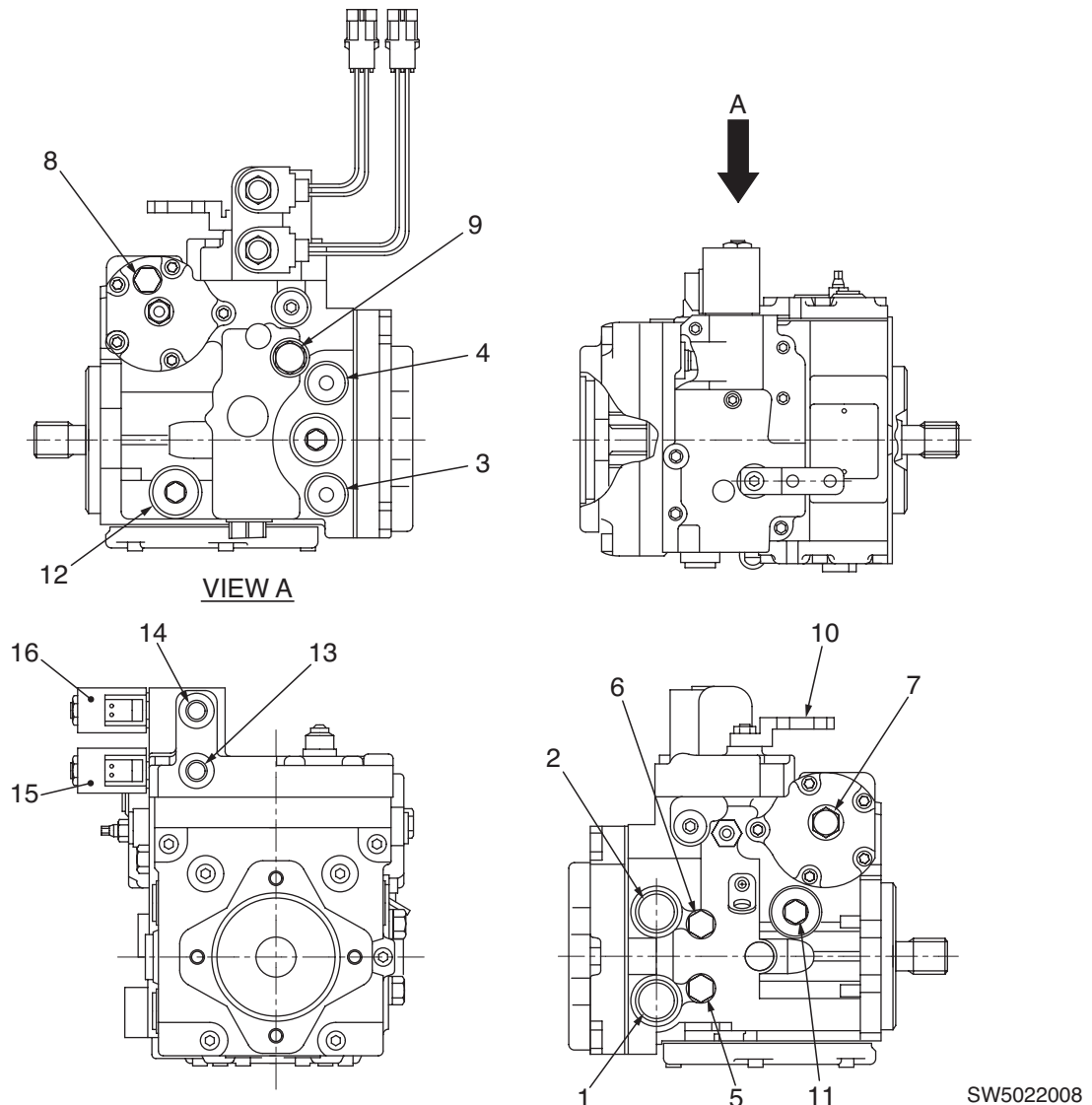

- | | |
|--------------------------------------|-----------------------------------|
| 1. Port A (forward travel) | 10. Control lever |
| 2. Port B (reversing) | 11. Case drain port |
| 3. Multi-function valve (port A) | 12. Case drain port |
| 4. Multi-function valve (port B) | 13. Brake release pressure port |
| 5. High pressure gauge port (port A) | 14. Speed shift pressure port |
| 6. High pressure gauge port (port B) | 15. Brake release solenoid valve |
| 7. Servo pressure gauge port | 16. Speed selector solenoid valve |
| 8. Servo pressure gauge port | |
| 9. Charge port | |

- Technical data (SW352, TW352)
- Model PVM28-608
 - Displacement: 28.0 cm³/rev (1.7 cu.in/rev)
 - Pressure setting: 34.5 MPa (352 kgf/cm²)
- Technical data (SW502, TW502)
- Model PVM32-604
 - Displacement: 31.5 cm³/rev (1.9 cu.in/rev)
 - Pressure setting: 34.5 MPa (352 kgf/cm²)

2-1-2. Rear vibrator pump assembly (SW352, SW502)

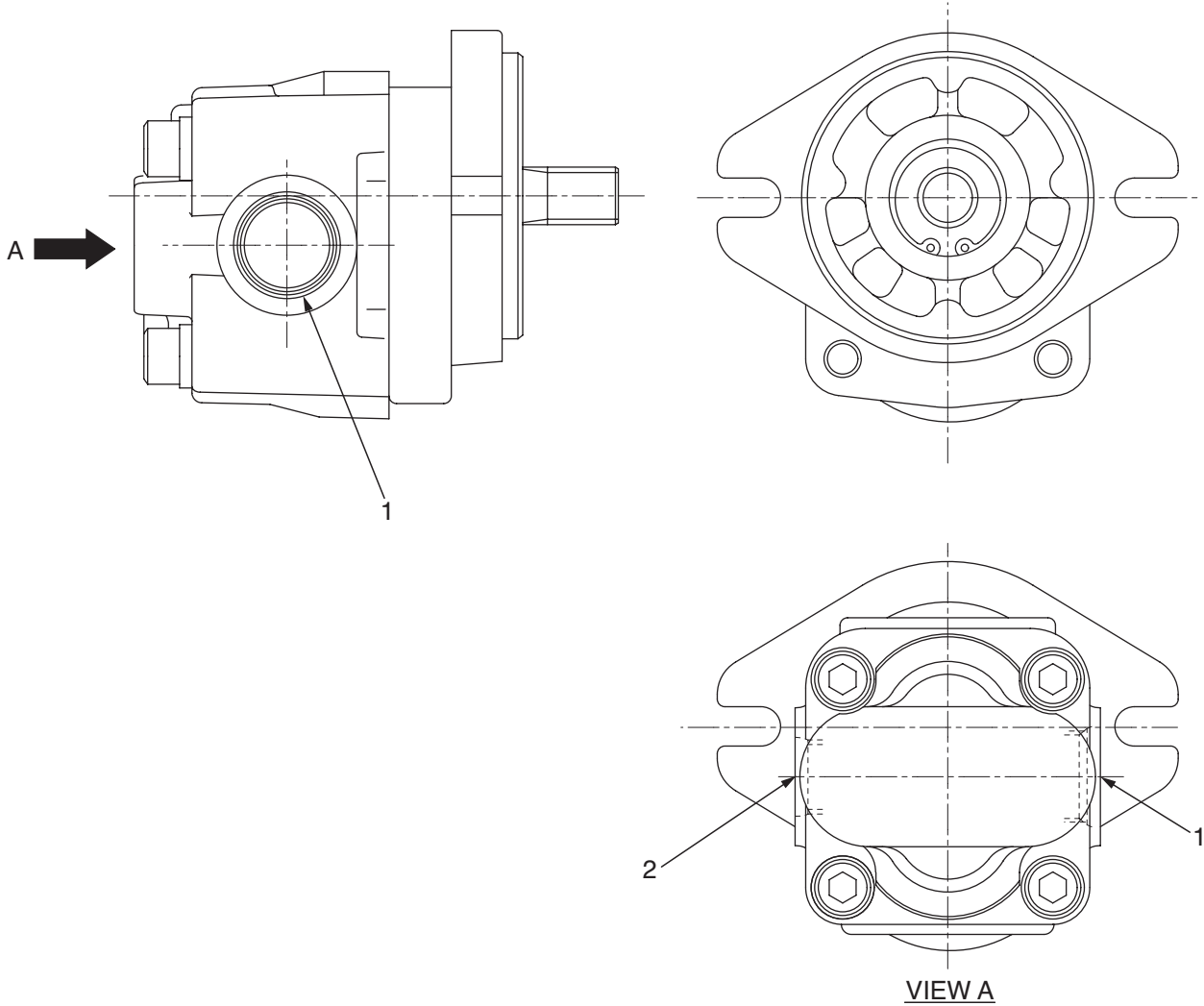

SW5022009

1. Inlet port
2. Outlet port

Technical data

- Model YP15A13A
- Displacement: 12.87 cm³/rev (0.8 cu.in/rev)
- Pressure setting: 12.7 MPa (130 kgf/cm³)

2-1-3. Front vibrator pump and steering/charge pump assembly

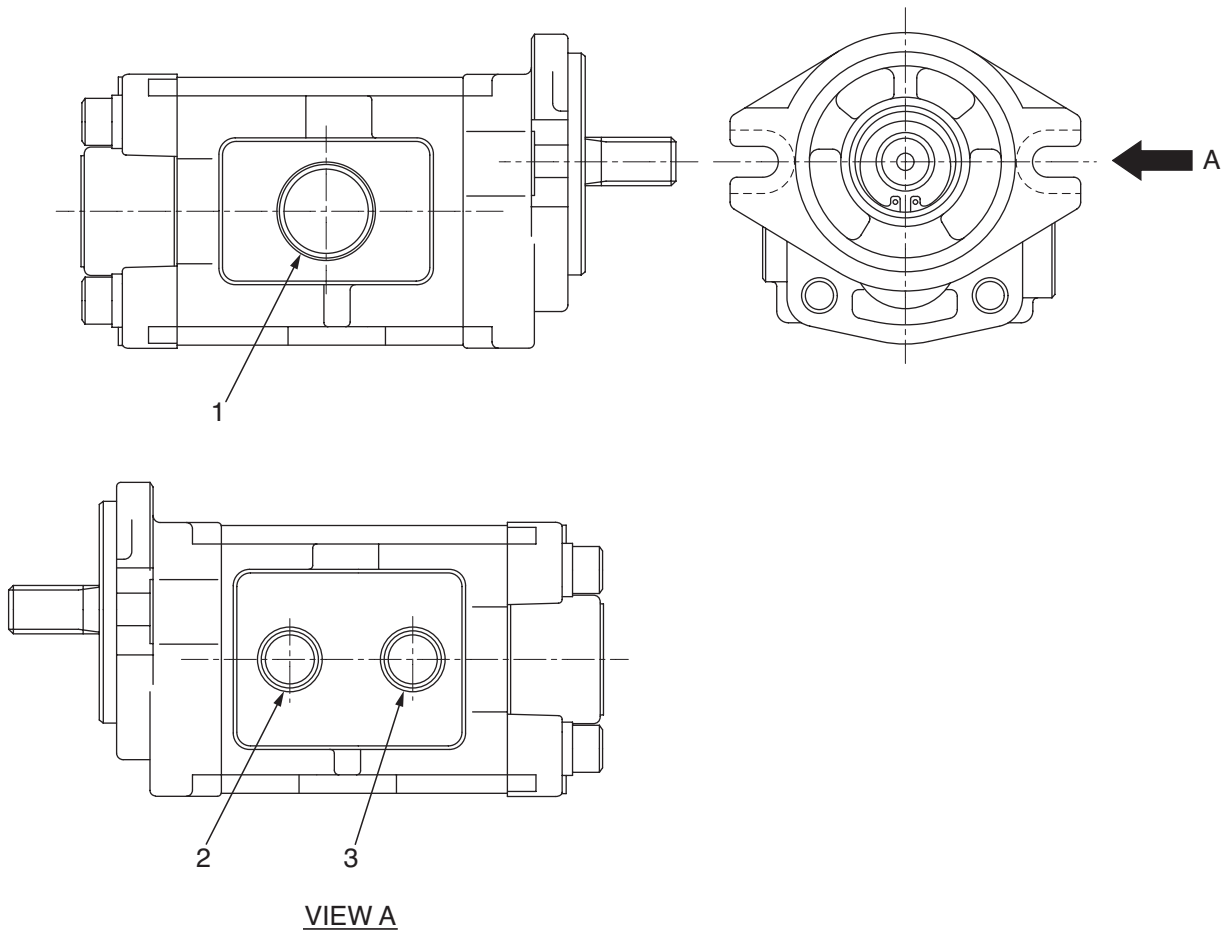

1. Inlet port
2. Outlet port (No.1 pump: Front vibrator)
3. Outlet port (No.2 pump: Steering/charge)

Technical data (No.1 pump)

- Model: DDG1A15·12
- Displacement: 15 cm³/rev (0.9 cu.in/rev)
- Pressure setting: 12.7 MPa (130 kgf/cm³)
(SW352, TW352)
- 14.4 MPa (147 kgf/cm³)
(SW502, TW502)

Technical data (No.2 pump)

- Displacement: 12.5 cm³/rev (0.8 cu.in/rev)
- Pressure setting: 3.5 MPa (138 kgf/cm³)

SW5022010

2-1-4. Hydraulic circuit diagram (SW352)

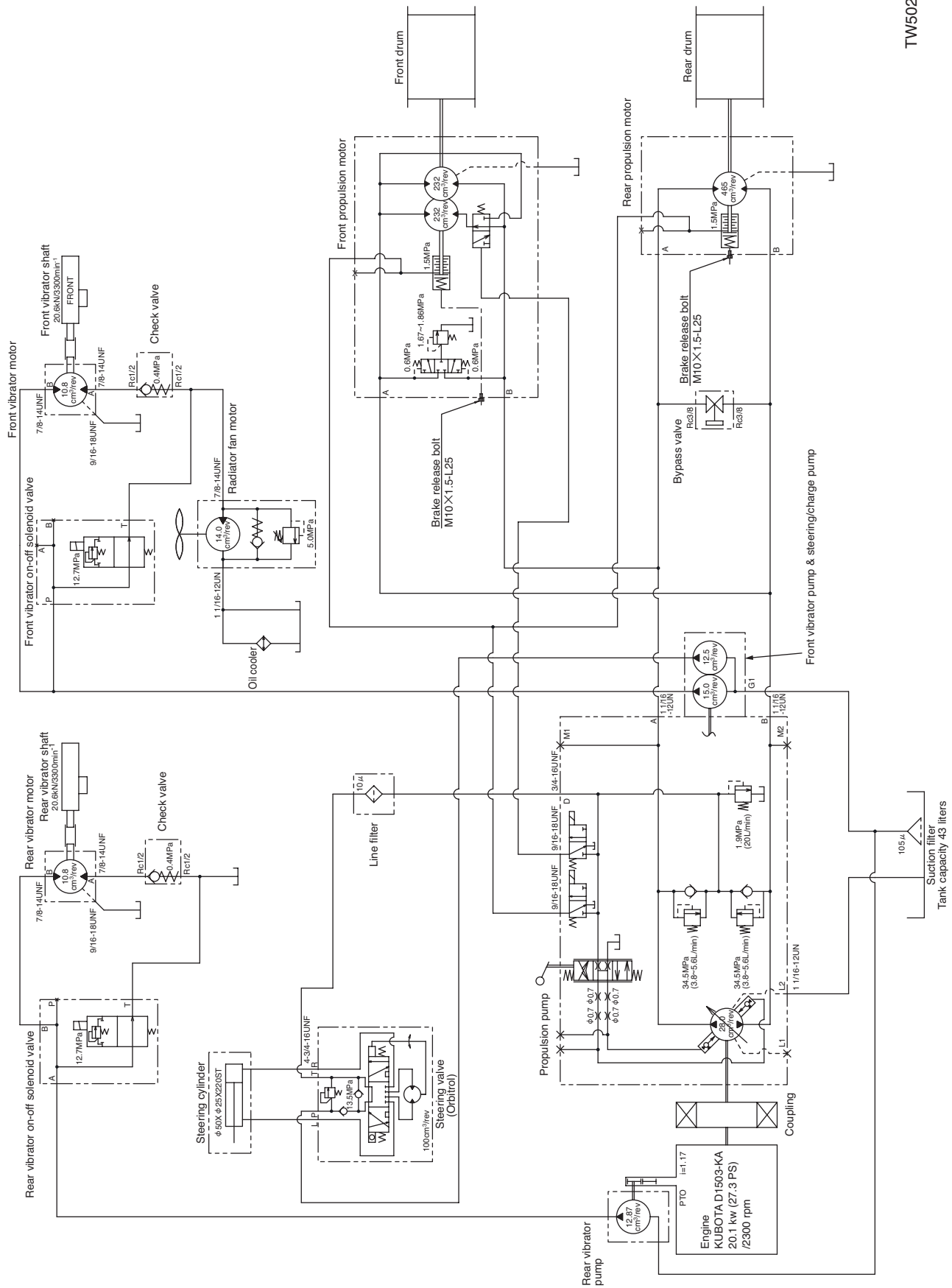

TW5022011

2-1-5. Hydraulic circuit diagram (SW502)

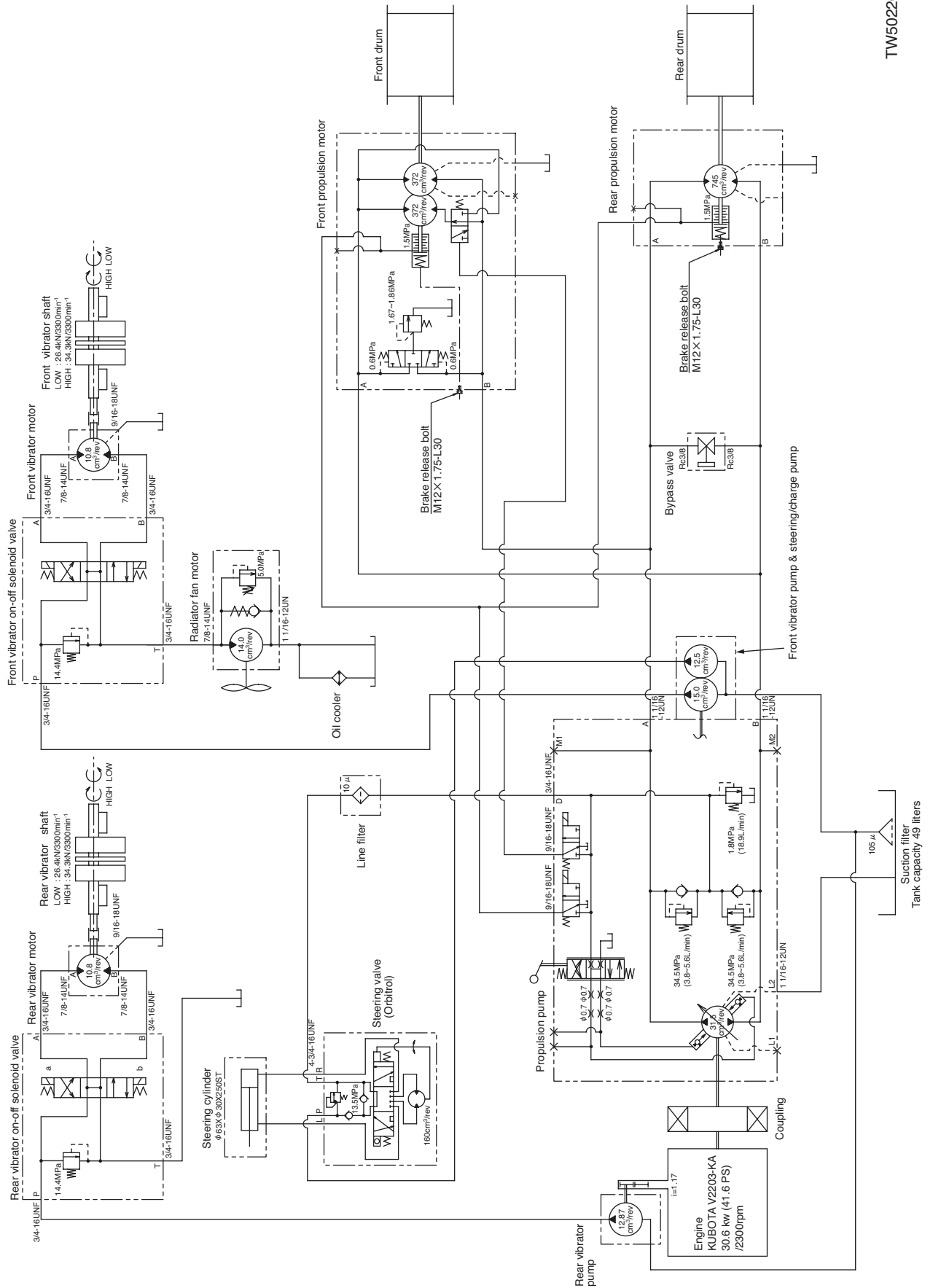

TW502012

2-1-6. Hydraulic circuit diagram (TW352)

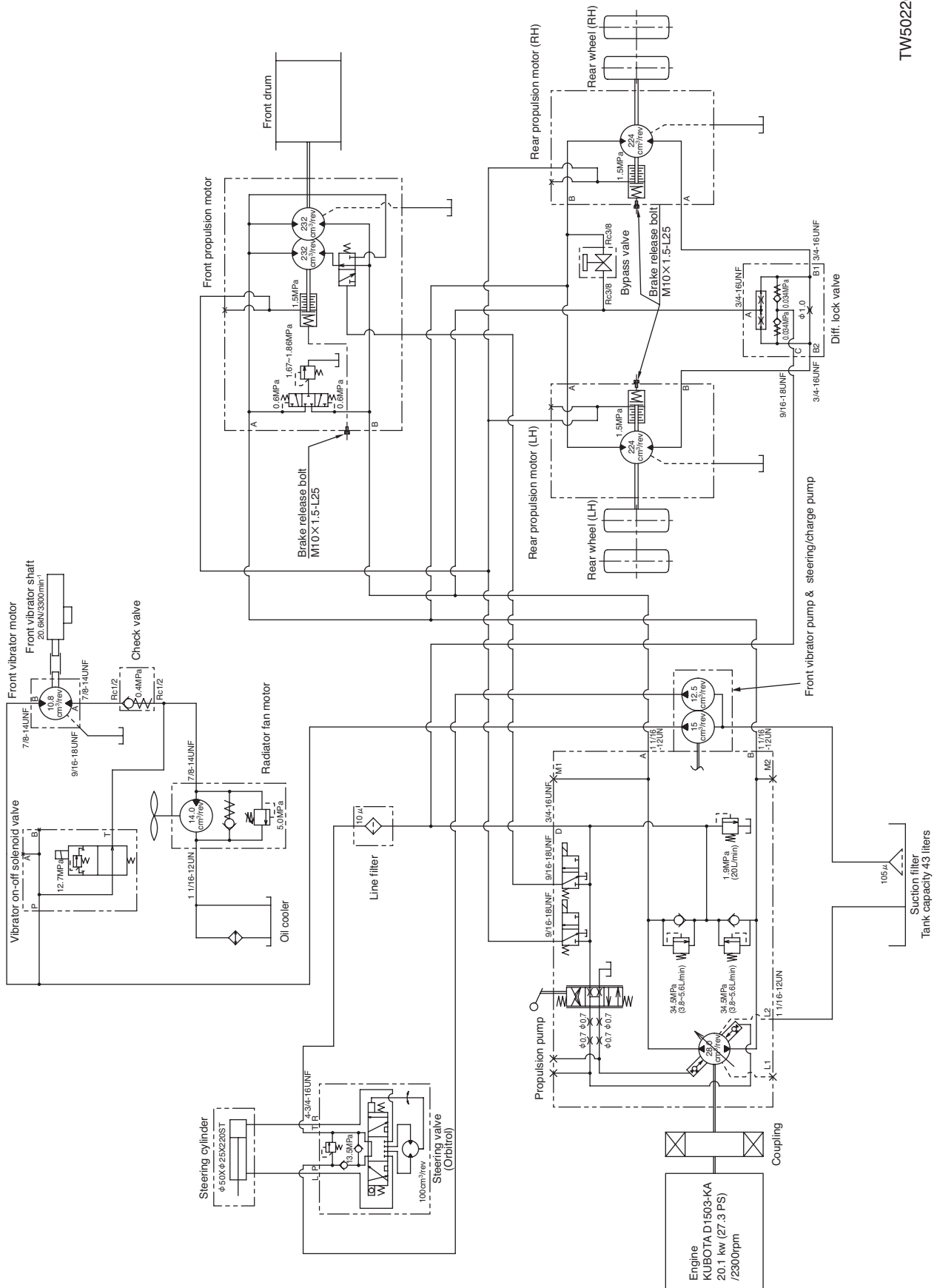

TW5022013

2-1-7. Hydraulic circuit diagram (TW502)

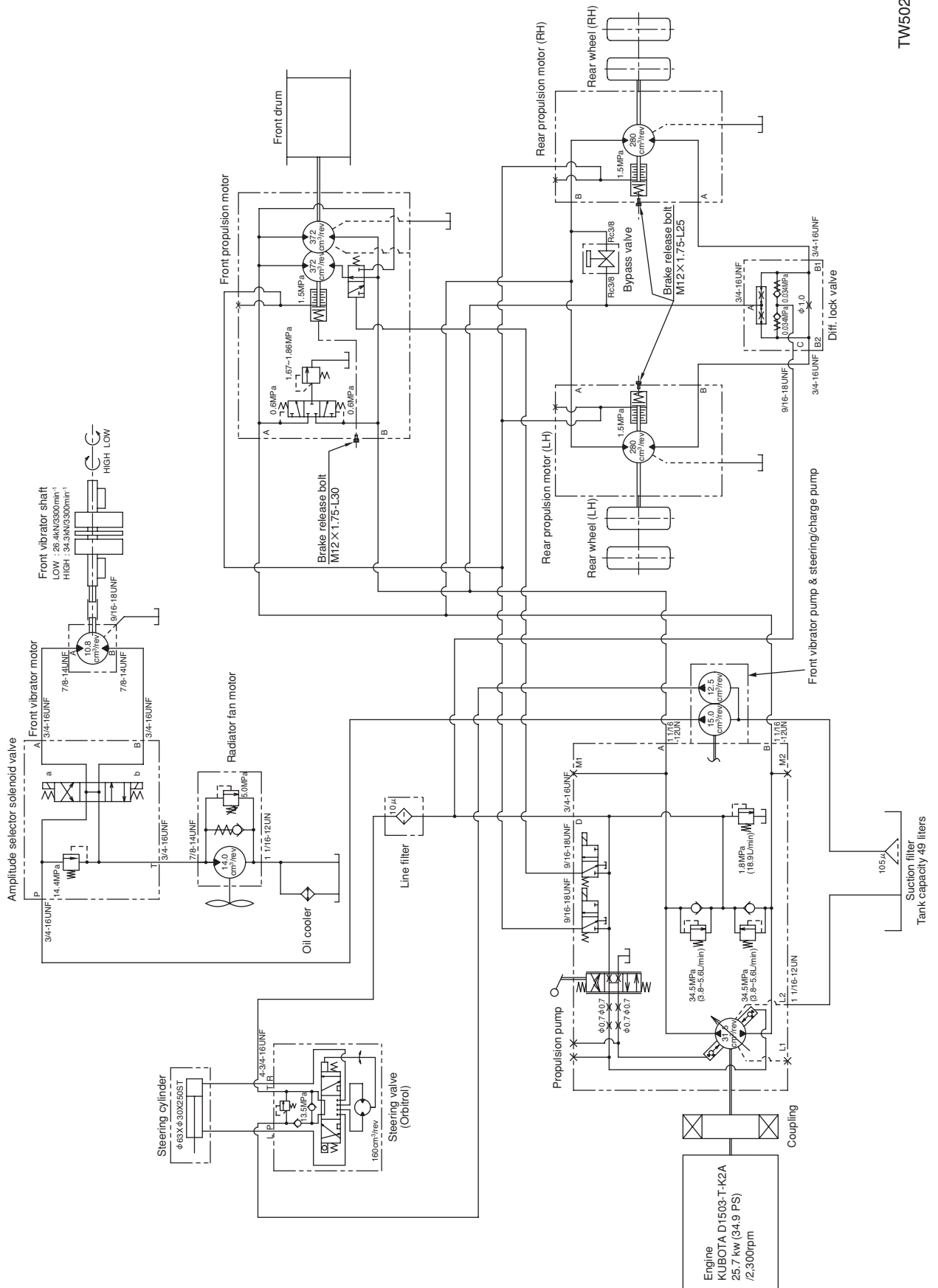

TW5020214

2-2. Propulsion line

2-2-1. Hydraulic piping (front)

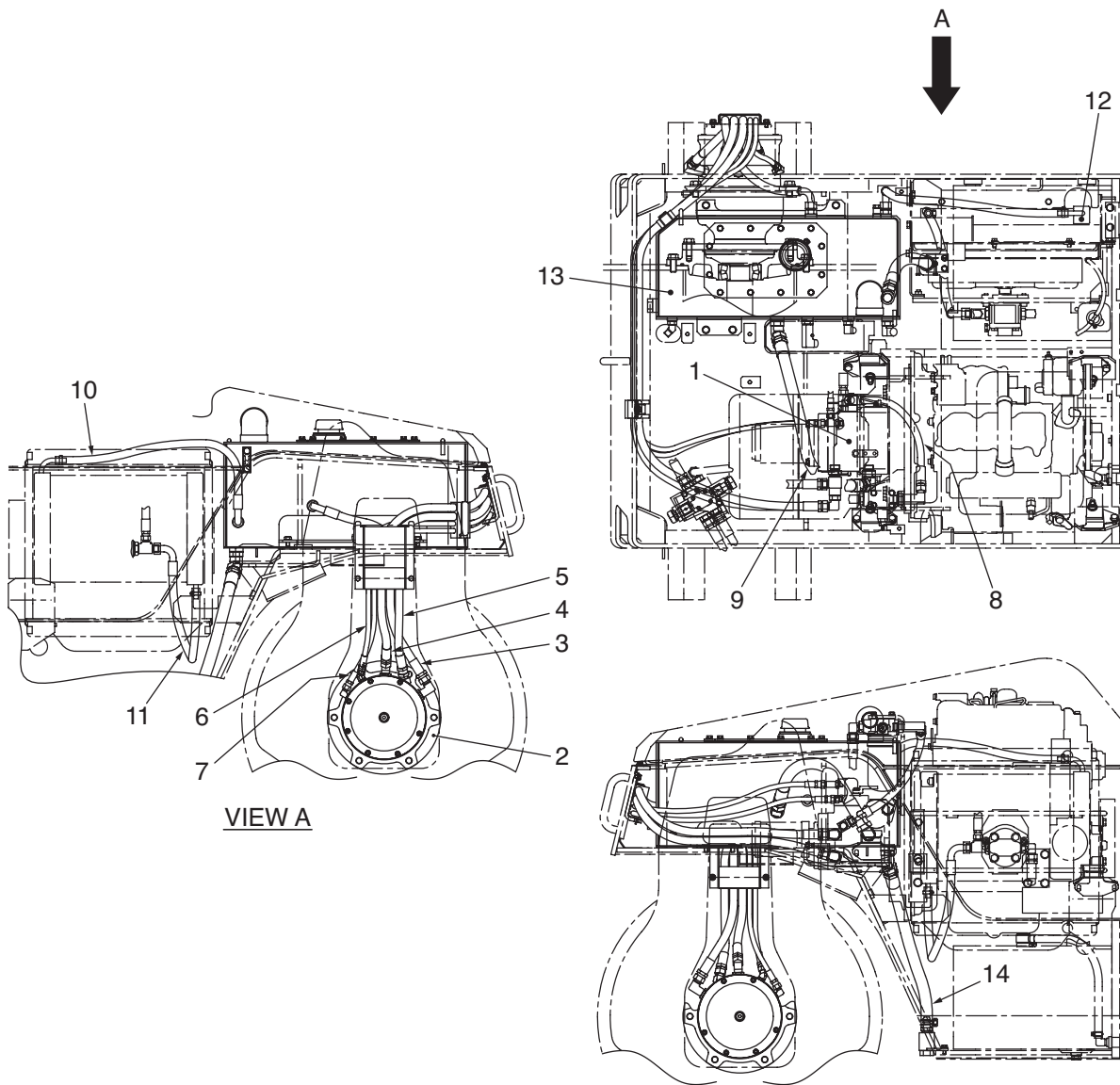

TW5022015

- | | |
|--|---------------------------------|
| 1. Propulsion pump | 8. Charge hose |
| 2. Propulsion motor (front) | 9. Drain hose (pump) |
| 3. High pressure hose (forward travel) | 10. Oil cooler outlet hose |
| 4. High pressure hose (reversing) | 11. Oil cooler inlet hose |
| 5. Drain hose (front motor) | 12. Oil cooler |
| 6. Brake release hose | 13. Hydraulic tank |
| 7. Speed selector hose | 14. Drain hose (hydraulic tank) |

★ Above figures illustrate the hydraulic piping of TW502.

2-2-2. Hydraulic piping (rear)

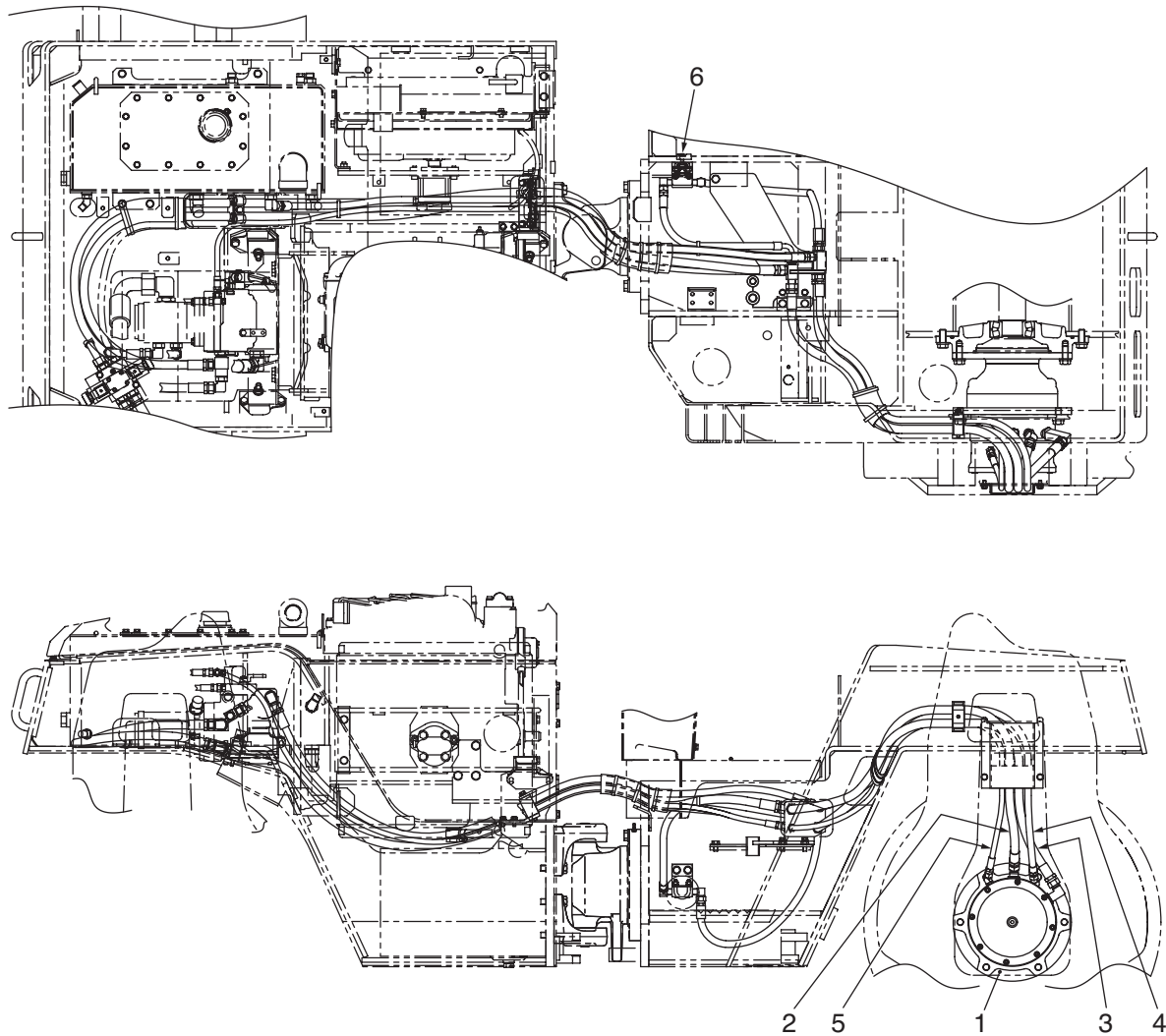

TW5022016

1. Rear propulsion motor
2. High pressure hose (forward travel)
3. High pressure hose (reversing)
4. Rear motor drain hose
5. Brake release hose
6. Bypass valve

★ Above illustrations represent the hydraulic piping of SW502.

2-2-3. Hydraulic piping (rear)

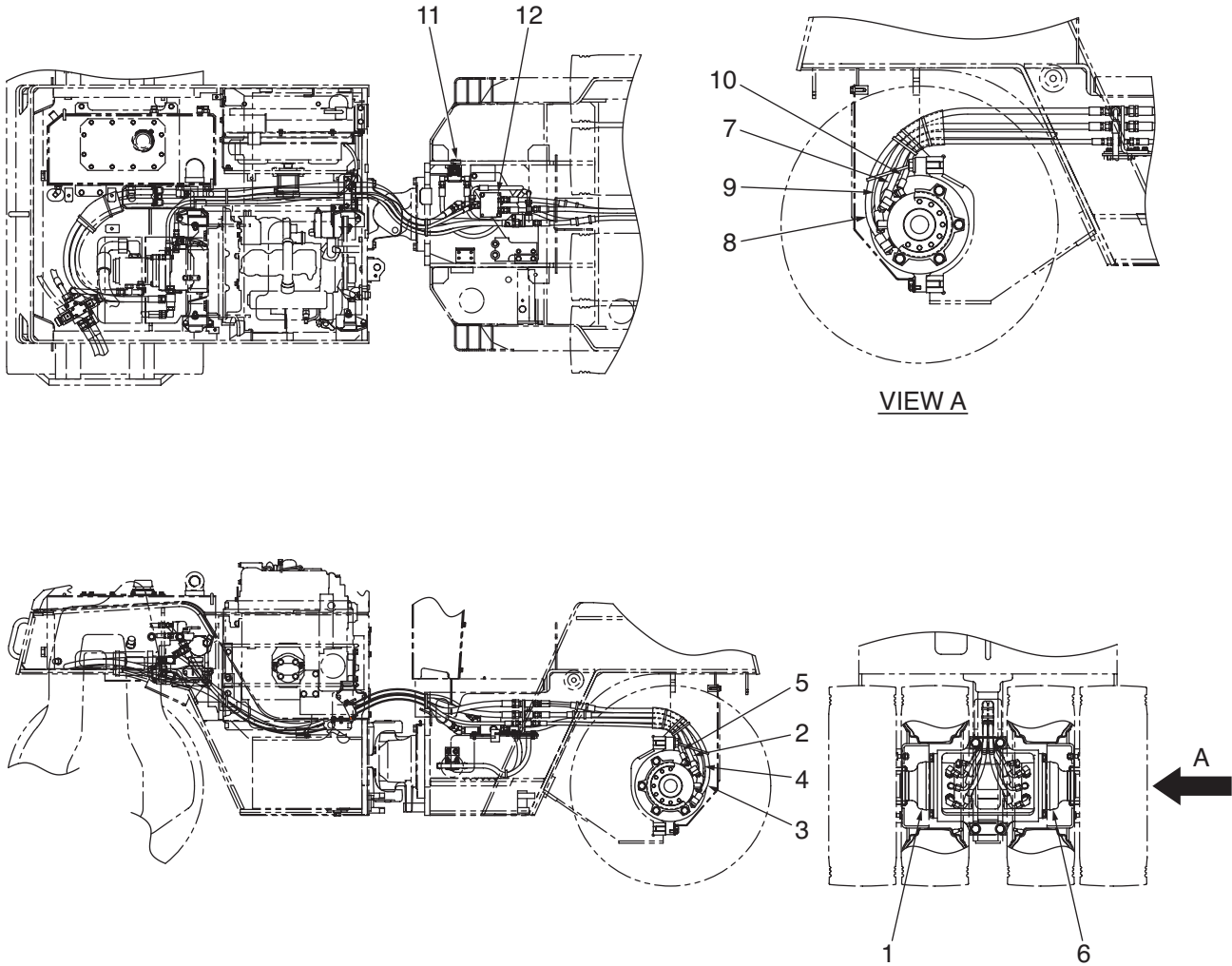

- | | |
|--|--|
| 1. Front propulsion motor (L.H.) | 7. High pressure hose (forward travel) |
| 2. High pressure hose (forward travel) | 8. High pressure hose (reversing) |
| 3. High pressure hose (reversing) | 9. Rear motor drain hose |
| 4. Rear motor drain hose | 10. Brake release hose |
| 5. Brake release hose | 11. Bypass valve |
| 6. Rear propulsion motor (R.H.) | 12. Diff. lock valve |

TW5022017

★ Above illustrations show the hydraulic piping of TW502.

2-2-4. Propulsion motor (cam motor) assembly (front)

★ Both motors have the same shape with different displacement.

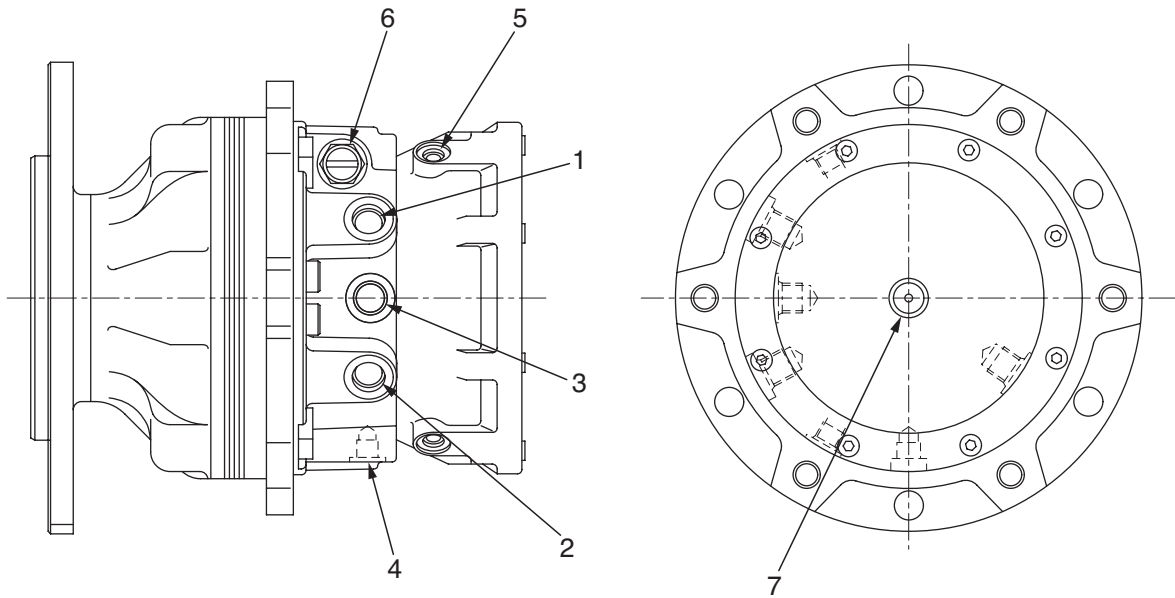

1. Port B (forward travel)
2. Port A (reversing)
3. Drain port
4. Speed selector port
5. Brake release port
6. Charge relief valve
7. Brake release port

Technical data (front of SW352, TW352)

- Model DCM0280-536
- Max. displacement: 465 cm³/rev (28.4 cu.in/rev)
- Min. displacement: 232 cm³/rev (14.2 cu.in/rev)
- Pressure setting: 34.3 MPa (350 kgf/cm³)

Technical data (front of SW502, TW502)

- Model DCM0560-548
- Max. displacement: 745 cm³/rev (45.4 cu.in/rev)
- Min. displacement: 372 cm³/rev (22.7 cu.in/rev)
- Pressure setting: 34.3 MPa (350 kgf/cm³)

TW5022018

2-2-5. Propulsion motor (cam motor) assembly (rear)

★ Both motors have the same shape but the displacement is different.

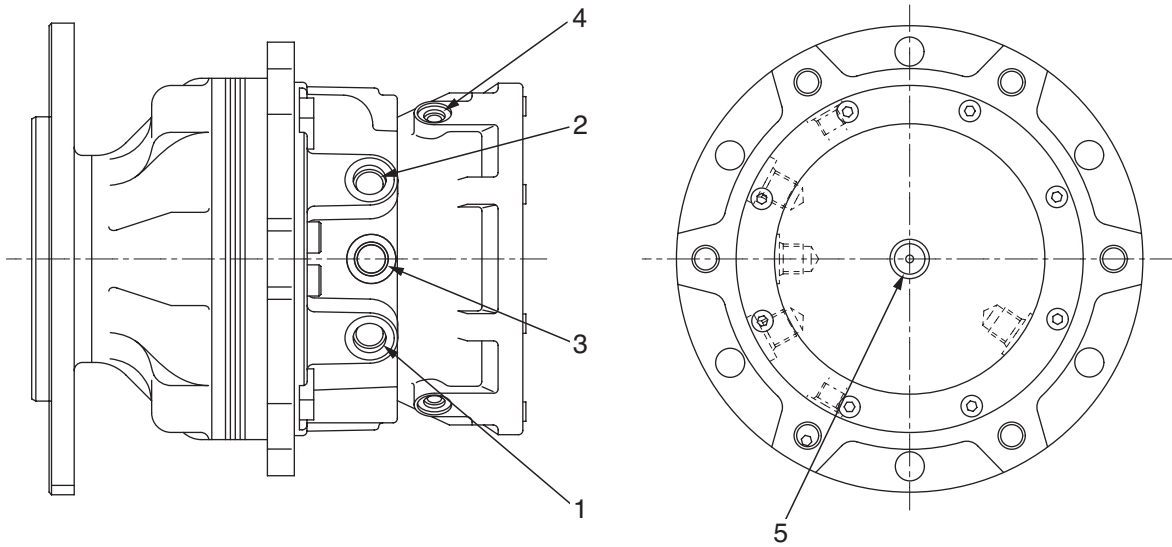

TW5022019

1. Port A (forward and reversing)
2. Port B (forward and reversing)
3. Drain port
4. Brake release port (imergency release)
5. Brake release port

Technical data (rear of SW352)

- Model: DCM0280-541
- Displacement: 465 cm³/rev (28.4 cu.in/rev)
- Pressure setting: 34.3 MPa (350 kgf/cm²)

Technical data (rear of TW352)

- Model: DCM0280-540
- Displacement: 224 cm³/rev (13.7 cu.in/rev)
- Pressure setting: 34.3 MPa (350 kgf/cm²)

Technical data (rear of SW502)

- Model: DCM0560-549
- Displacement: 745 cm³/rev (45.4 cu.in/rev)
- Pressure setting: 34.3 MPa (350 kgf/cm²)

Technical data (rear of TW502)

- Model: DCM0280-542
- Displacement: 280 cm³/rev
- Pressure setting: 41.2 MPa (420 kgf/cm²)

2-2-6. Description and operation of cam motor

Construction of cam motor

- The cam motor is made up of output flange (1), housing (2), cam ring (4), end cap (5), brake housing (6), brake cover (9), cylinder block (10), distributor (11), speed selector valve (12) and flushing valve (13), etc.
- ★ The front propulsion line uses cam motors with speed selector valve (12) built in it.
- Eight sets of piston (3) stay assembled into cylinder block (10), while brake housing (6) houses brake spring (7), brake piston (8) and brake discs (14).
- Housing (2), cam ring (4), end cap (5), brake housing (6) and brake cover (9) form one body fastened together with securing bolts.
- Cylinder block (10) is spline-fitted to output flange (1) and rotates together when the hydraulic pressure is fed. Cylinder block (10) has twelve oil ports which align with corresponding ports of distributor (11).
- Distributor (11) fitted to end cap (5) with a dowel pin feeds oil fed from port A or port B of end cap (5) to cylinder block (10) and also displaces oil from cylinder block (10). For this purpose, there are twelve oil ports in distributor (11) to negotiate the six cam shapes of cam ring (4).

Front propulsion motor

- Speed selector valve (12) is fitted between ports A and B of end cap (5) and distributor (11). One port of speed selector valve (12) leads to three ports of distributor (11).

Rear propulsion motor

- Port A of end cap (5) connects to six ports of distributor (11) and the other port B to remaining six ports of the distributor.
- Cam ring (4) has six cam profiles on its inside surface (See P.2-024) along which the pistons move to provide a rotary motion.
- Eight sets of pistons (3) are assembled into cylinder block (10) and the whole cylinder block assembly is housed inside cam ring (4).

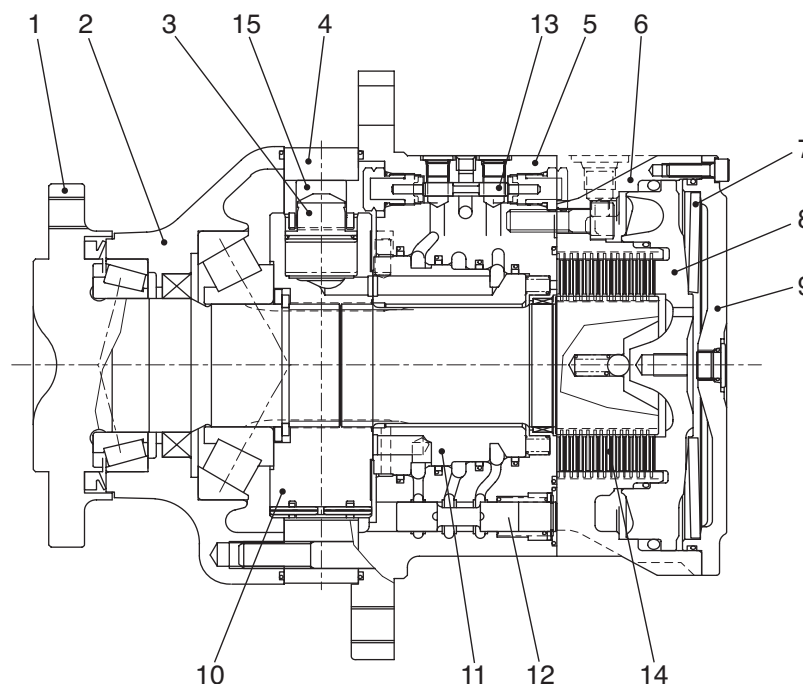

TW5022020

Font propulsion motor (cam motor fitted with speed selector valve)

Operation

★ It is assumed that oil is fed into port A of the motor.

Selection of low speed

★ Spool operating pressure: lower than 0.2 MPa (2 kgf/cm²)

• Pump flow into port A of end cap (5) is distributed, from two ports of speed selector valve (12), into six ports of distributor (11).

★ Remaining six ports act as exhaust ports.

• Pistons (3) moving together with rollers (15) along the cam profiles make cylinder block (10) create a rotary force. This force is conveyed to output flange (1) spline-fitted to cylinder block (10).

• At the same time, pistons (3) leading to exhaust port (port B) move along the cam profile and toward the center of cylinder block (10) to exhaust oil from port B.

★ If pump flow is fed to port B, output flange (1) spins in the opposite direction.

■ : High main pressure
□ : Low main pressure

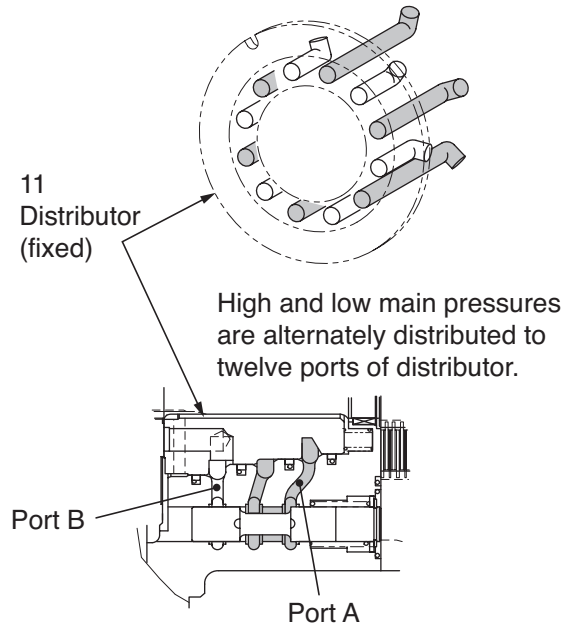

TW5022021

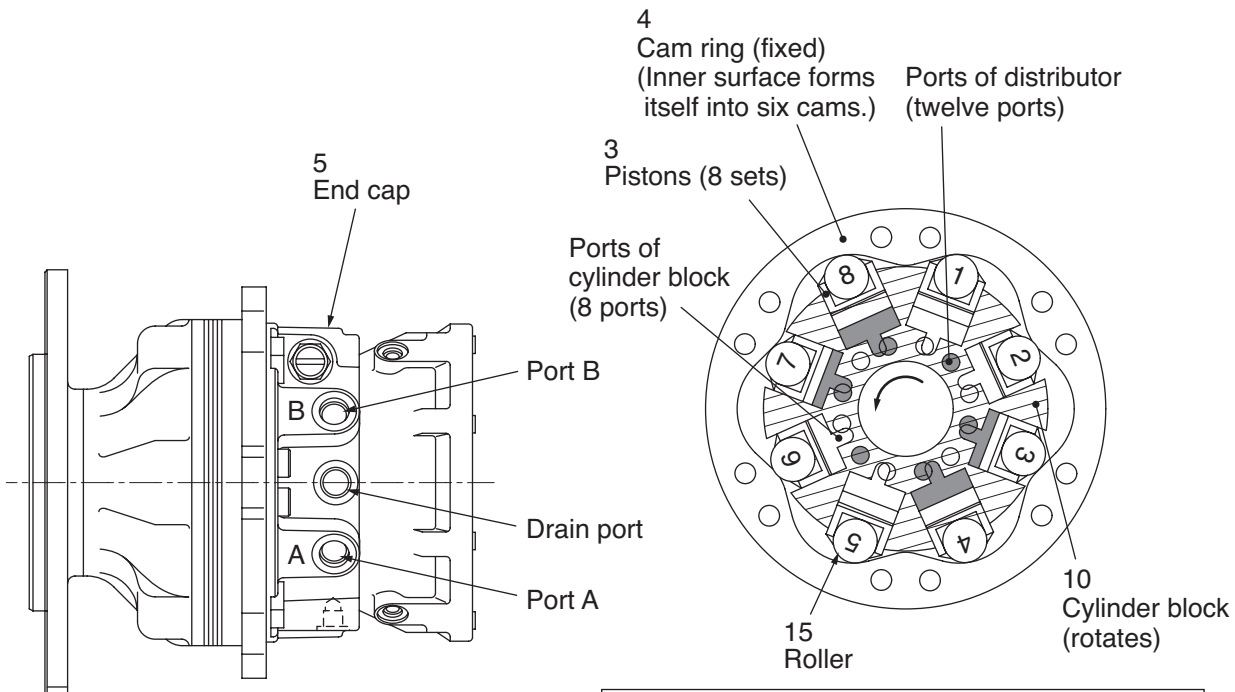

TW5022023

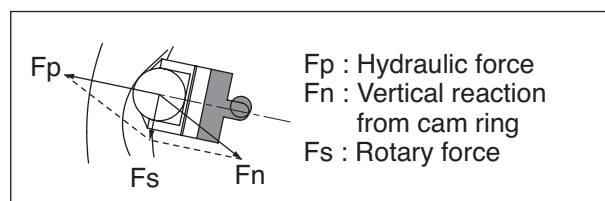

TW5022022

Selection of High speed

★ **Spool operating pilot pressure: 1.0-4.9 MPa (10-50 kgf/cm²)**

- Two of three ports lead to distributor (11) with speed selector valve (12) moved in the direction shown by arrow.
- This movement causes the high-pressure oil to flow into three of twelve ports of distributor (11). Other three ports connect to the low-pressure ports with the remaining six ports leading to the charge pressure circuit.
- This action feeds high-pressure oil into three of twelve ports of cylinder block (10). As a result, only a half of ports feeds the pressurized oil to pistons (3). This drives pistons (3) faster with the pump delivery remaining constant. The motor runs more rapidly.

: Main high pressure
 : Main low pressure
 : Charge pressure

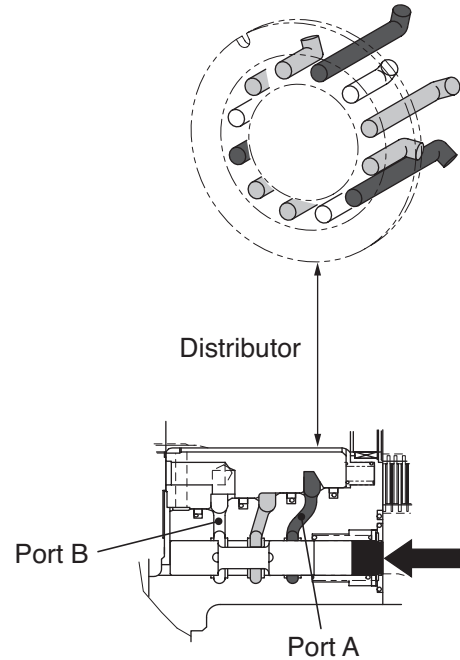

TW5022024

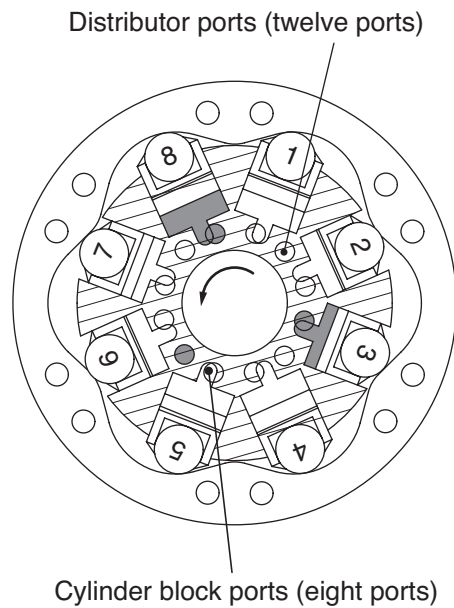

TW5022025

Rear propulsion motor (cam motor with speed selector valve not fitted)

Operation

★ It is assumed oil is fed into port A of motor.

- Pump flow into port A of end cap (5) is distributed to six ports of distributor (11) which lead to port A.
- ★ The remaining six ports act as exhaust ports.
 - If six ports of cylinder block (10) lead to six ports of distributor (11), high pressure-oil moves pistons outward.
 - Because pistons (3) move along the cam profiles together with rollers (15), rotary force is generated in cylinder block (10). This rotary force is transmitted to output flange (1) spline-fitted to cylinder block (10). Output flange (1) is driven.
 - Simultaneously, pistons (3) leading to the exhaust port (port B) move along the cam profiles and, at the same time, outward to exhaust oil from port A.
- ★ If pump flow is fed to port B, output flange (1) turns in the reverse direction.

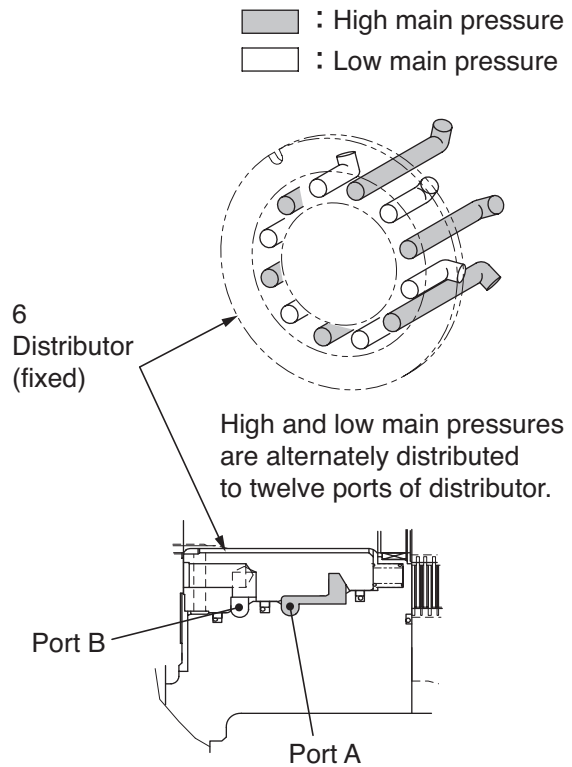

TW5022026

2-2-7. Rear axle assembly (TW352, TW502)

★ Wide tire version

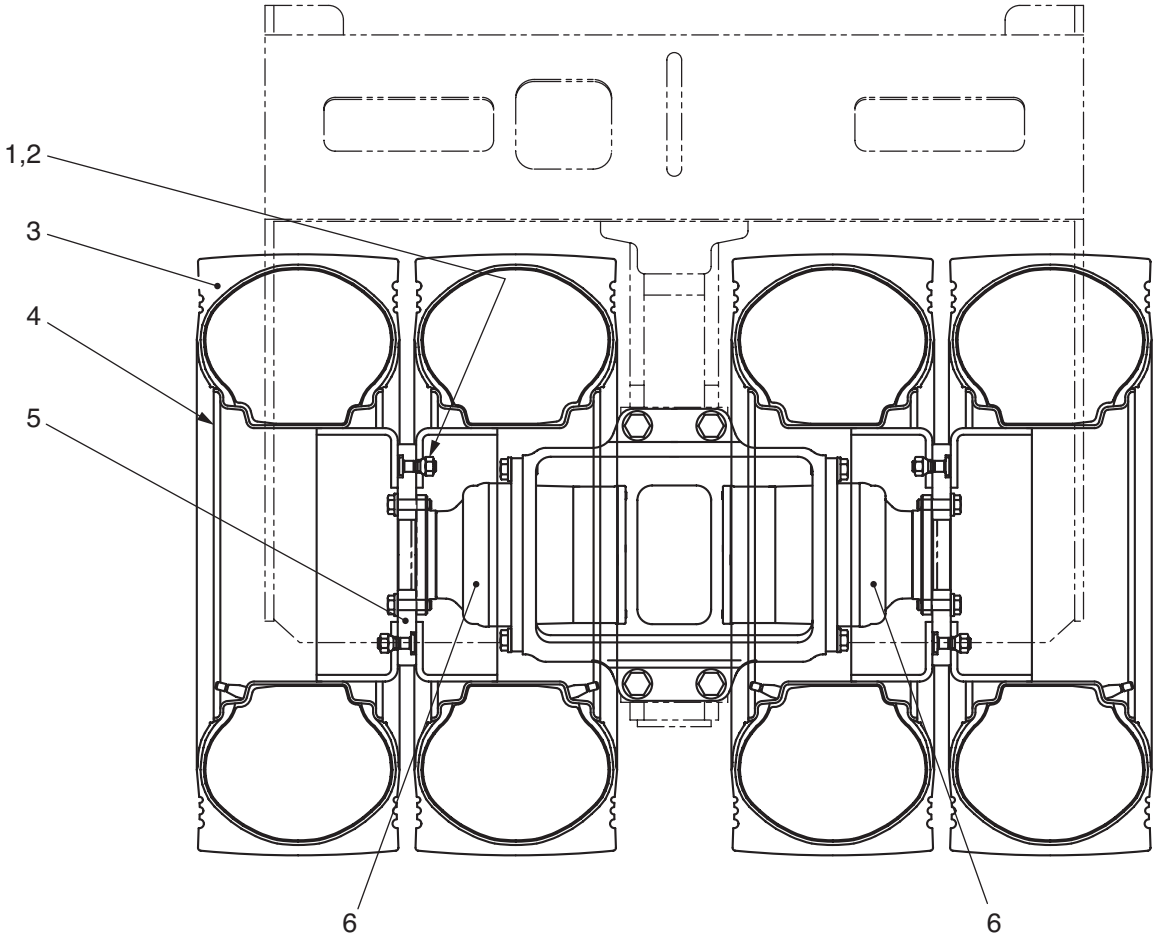

TW5022027

- 1. Hub bolt
- 2. Hub nut
- 3. Tire

- 4. Disc wheel
- 5. Disc
- 6. Propulsion motor

2-2-8. Propulsion controls

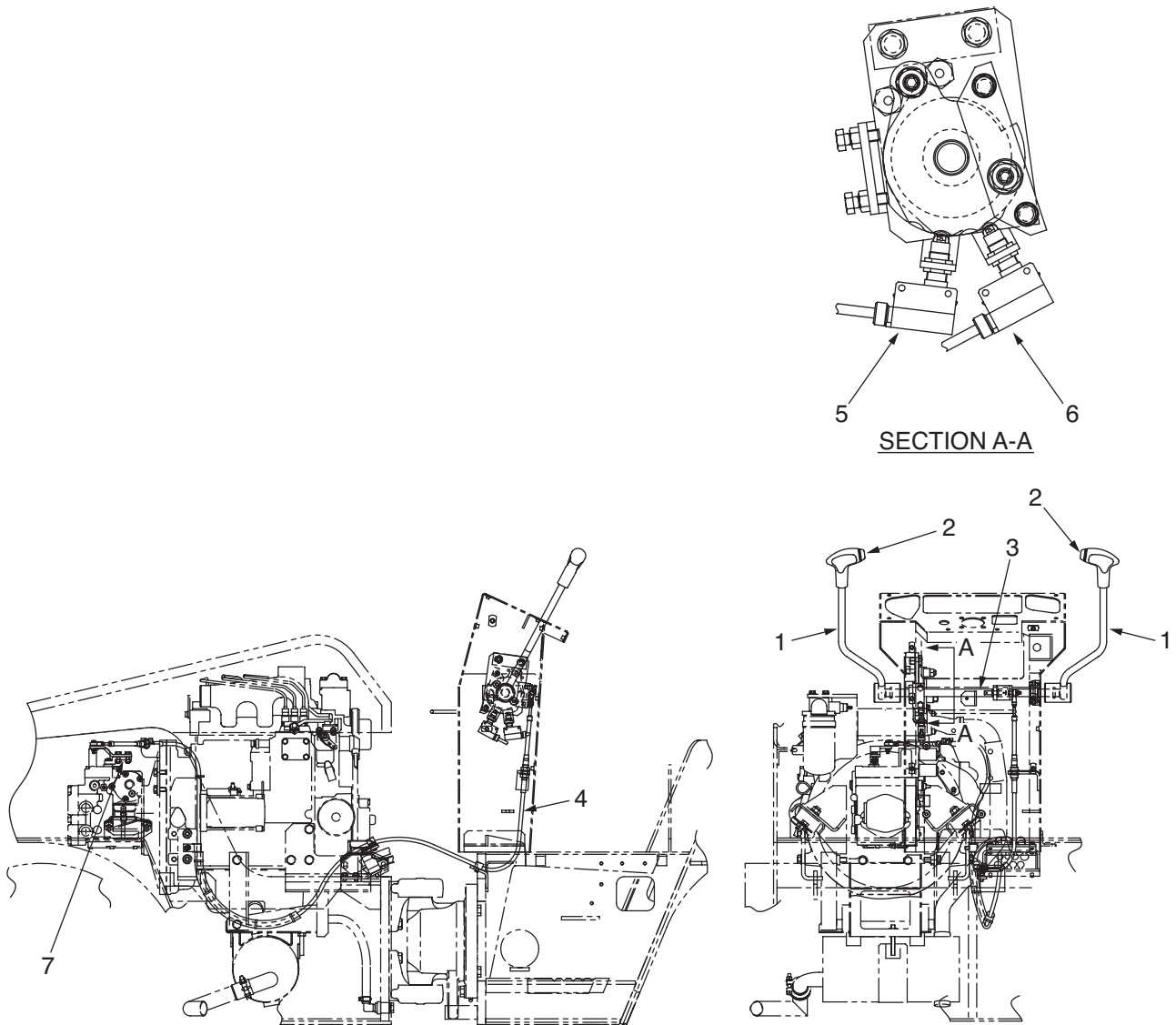

- | | |
|--------------------------------|-------------------------|
| 1. Forward-reverse (F-R) lever | 5. Interlock switch |
| 2. Vibrator on-off switch | 6. Reverse alarm switch |
| 3. Shaft | 7. Control lever |
| 4. Control cable | |

TW5022028

2-2-9. Propulsion circuit diagram (SW352, SW502)

1. Engine
2. Coupling
3. Propulsion pump
 - a. Control valve
 - b. Servo piston
 - c. Multi-function valve
 - d. Charge relief valve
 - e. Brake release solenoid valve
 - f. Speed selector solenoid valve
4. Steering/charge pump
5. Bypass valve
6. Front propulsion motor assembly (cam motor)
 - g. Speed selector valve
 - h. Spring-applied hydraulically released brake
 - i. Flushing valve
 - j. Low pressure relief valve
 - k. Brake release bolt
7. Front drum
8. Rear propulsion motor assembly (cam motor)
9. Rear drum
10. Suction filter
11. Steering valve (Orbitrol)
 - m. Pressure relief valve
12. Line filter

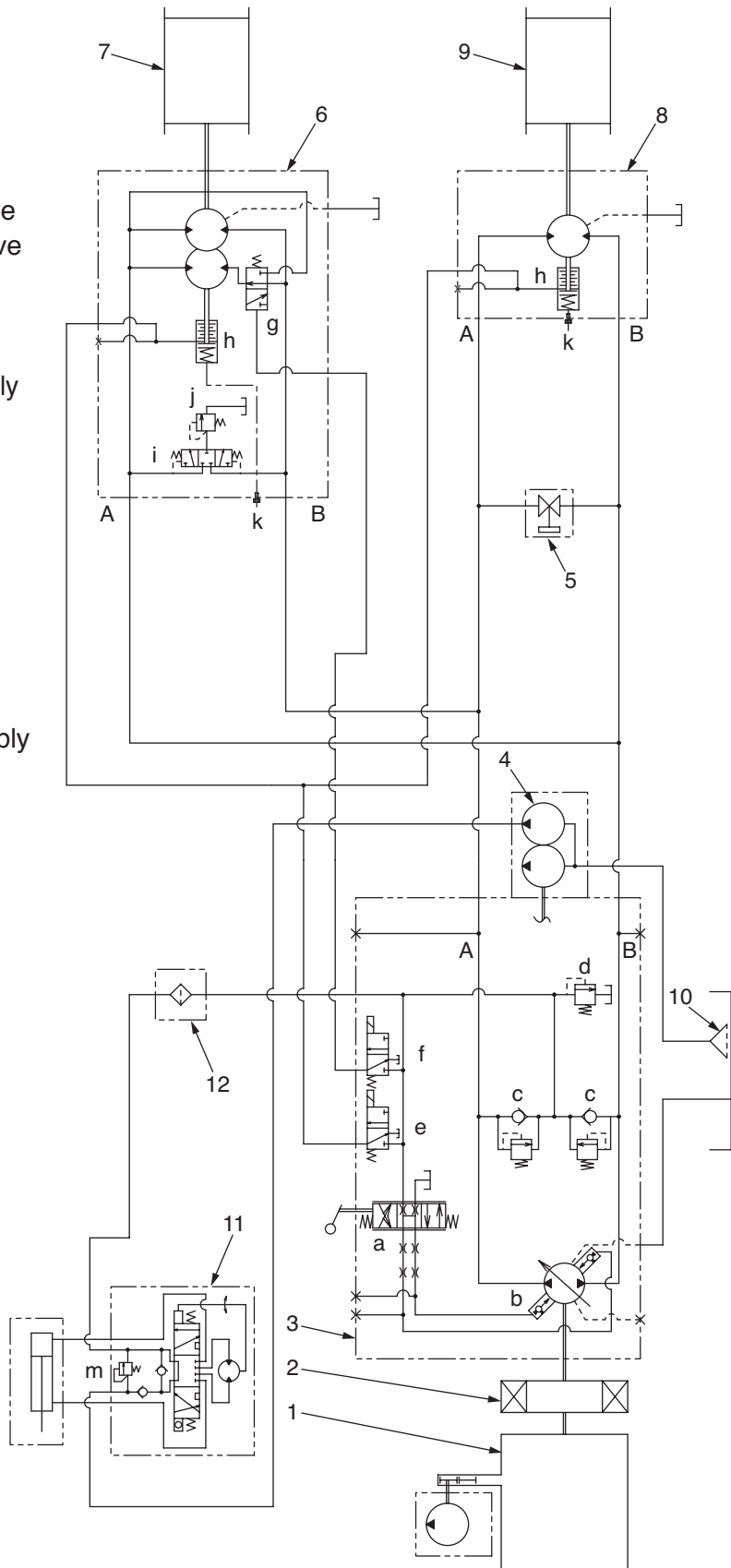

TW5022029

2-2-10. Propulsion circuit diagram (TW352, TW502)

1. Engine
2. Coupling
3. Propulsion pump
 - a. Control valve
 - b. Servo piston
 - c. Multi-function valve
 - d. Charge relief valve
 - e. Brake release solenoid valve
 - f. Speed selector solenoid valve
4. Steering/charge pump
5. Front propulsion motor assembly (cam motor)
 - g. Speed selector valve
 - h. Spring-applied hydraulically released brake
 - i. Flushing valve
 - j. Low pressure relief valve
 - k. Brake release bolt
6. Front drum
7. Left-hand rear propulsion motor assembly (cam motor)
8. Left-hand rear wheel
9. Right-hand rear propulsion motor assembly (cam motor)
10. Right-hand rear wheel
11. Steering valve (Orbitrol)
 - m. Pressure relief valve
12. Line filter
13. Differential lock valve assembly
14. Bypass valve
15. Suction filter

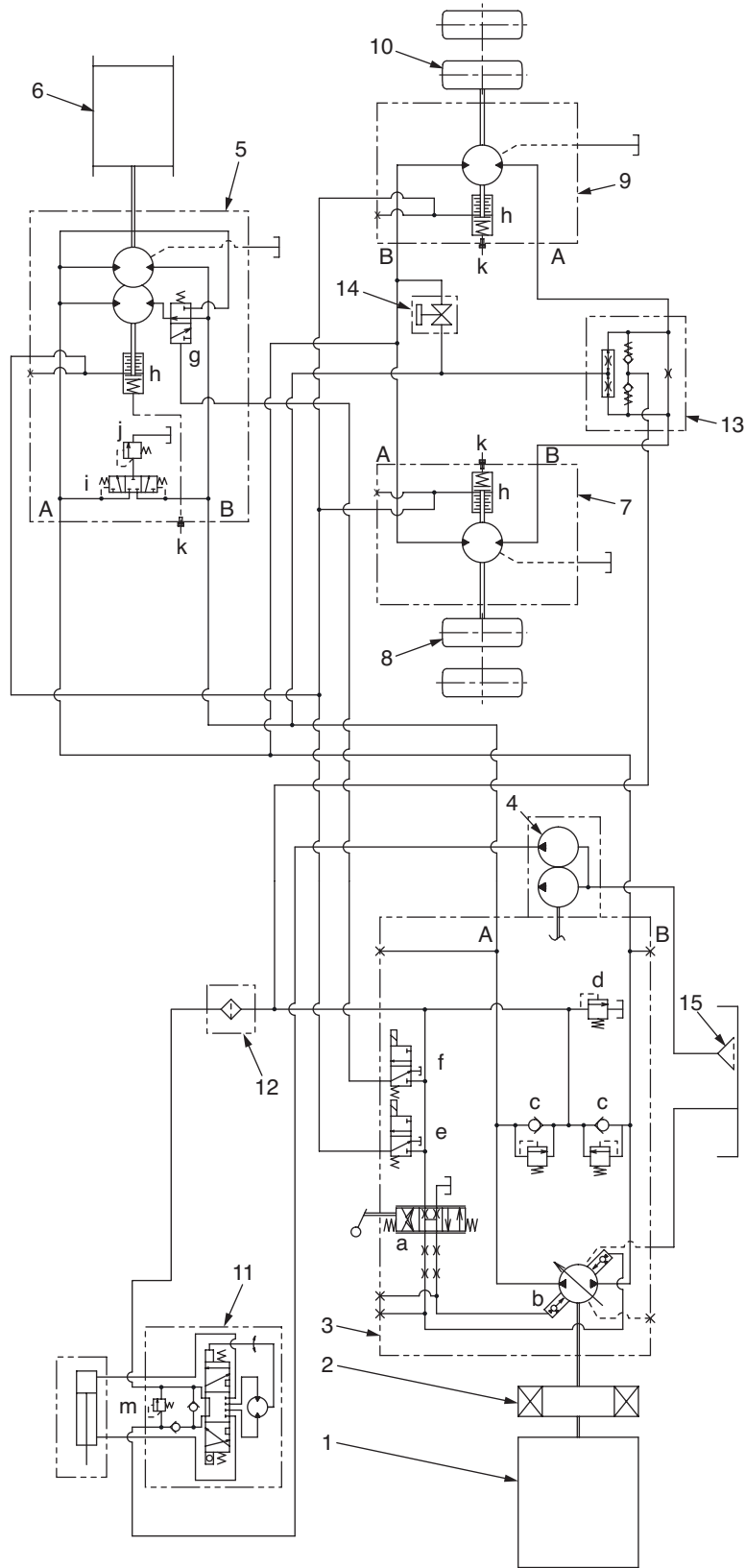

TW5022030

2-2-11. Description and operation of propulsion system

*** See the hydraulic circuit diagrams, pages 2-029 and 2-030.**

Description of propulsion system

SW352, SW502

- Comprises propulsion pump (3), front propulsion motor (cam motor) (6), front drum (7), rear propulsion motor (cam motor) (8) and rear drum (9). Brake release solenoid valve (e) and speed selector valve (f) are built into the propulsion pump.

TW352, TW502

- Consists of propulsion pump (3), front propulsion motor (cam motor) (5), front drum (6), left-hand rear propulsion motor (cam motor) (7), right-hand rear propulsion motor (cam motor) (9), left-hand rear wheels (8) and right-hand rear wheels (10). Brake release solenoid valve (e) and speed selector valve (f) are built into the propulsion pump.

Fundamental function of propulsion pump and propulsion motor

Propulsion pump

- A piston pump shifts speed and selects forward travel, neutral drive and backing by varying the angular position of swashplate, and thus varying the piston stroke.

Front propulsion motor

- A radial piston motor (cam motor) selects speed by operating the speed selector valve built in the motor. Feeding the pump flow to four of eight pistons offers 'Low speed range', while supplying to two pistons selects 'High speed'.

Rear propulsion motor

- The rear propulsion motor (SW352, TW352, SW502, TW502) uses a fixed displacement radial piston motor (cam motor). Choice of two speeds in the front motor varies the amount of oil flowing into the rear motor.

Operation

- ★ It is assumed that the machine is propelled forward.
- ★ The spring-applied hydraulically released brake (negative brake) is supposed to remain released.
- ★ Assemblies such as pump assembly and motor assembly are indicated by numbers such as (1) and (2), while component parts of assemblies are shown by small letters like (a) and (b).

SW352, SW502

- ★ The front and rear motors connect together in parallel in their hydraulic circuit.
- Moving the forward-reverse (F-R) lever forward makes control valve (a) work to allow servo piston (b) to tilt the pump swashplate in the forward travel direction.
- Propulsion pump (3) feeds oil from its port A (forward travel circuit) into the forward travel line, then the flow branches into two lines; one line connecting to forward travel port B of front motor (6), and the other line leading to forward travel port A of rear motor (8).
- The oil fed to the forward travel port of motors drives the motors, flowing out from the opposite side ports and joins again to flow into inlet port B of propulsion pump (3). At the same time, part of oil in the circuit connecting to port A of front motor (6) passes through flushing valve (i), opens low pressure relief valve (j), and is drained into the tank through the motor casing. Flushing valve (i) makes part of oil in the circuit return to the tank to remove foreign material present in hydraulic oil, and also to cool oil.
- Because front motor (6) and rear motor (8) are of a cam type, they have a characteristic of reducing speed, directly driving front drum (7) and rear drum (9).
- ★ Because the propulsion circuit is a closed loop circuit, the suction port and exhaust port exchange their role each other when the travel direction is reversed. (The direction of oil flow is reversed.)

Releasing of spring-applied hydraulically released brake (negative brake)

- When energized, brake release solenoid valve (e) feeds oil from the charge circuit into the brake release ports of front motor (6) and rear motor (8).
- Oil then flows into the cylinder built in brake unit (h). The piston inside the cylinder moves in the direction to release the brake against the compression spring load.

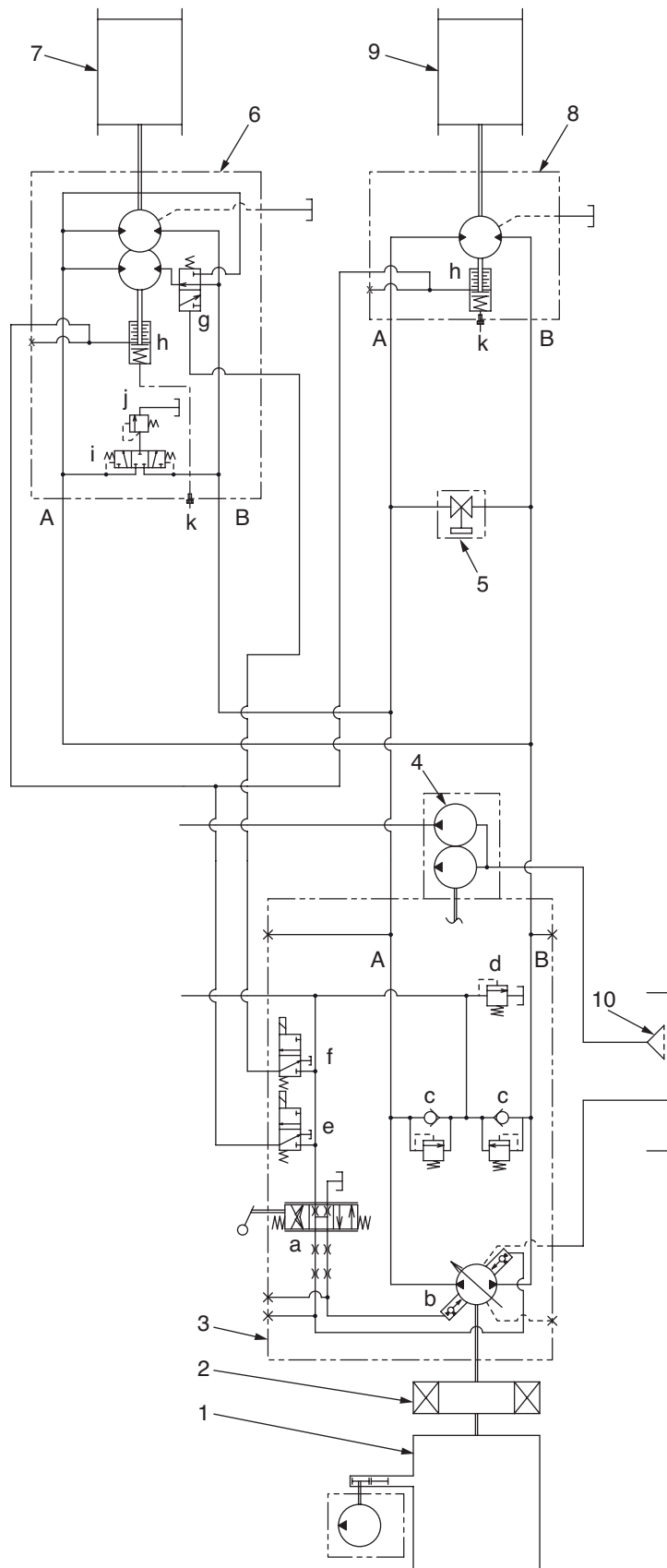

TW5022031

TW352, TW502

- The propulsion system is a combination of a propulsion pump and three propulsion motors (cam motors). The front and rear motors connect with each other in parallel in their hydraulic circuit.
- Moving the forward-reverse lever forward makes servo piston (b) of control valve (a) function to tilt the pump swashplate in the forward drive direction.
- By this operation, propulsion pump (3) feeds oil from its port A into the forward drive line, then the flow branches into three lines; one line connecting to forward drive port B of front motor (5), the other line leading to forward drive port B of rear motor (L.H.) (7) and another line going to forward drive port A of rear motor (R.H.) (9).
- Because front motor (5), left-hand rear motor (7) and right-hand rear motor (9) are cam motors, they have a speed reducing characteristic, directly driving front drum (6), left-hand rear wheels (8) and right-hand rear wheels (10).
- ★ Because the propulsion circuit is a closed loop circuit, the suction port and exhaust port exchange their role when the travel direction is reversed. (The direction of oil flow is reversed.)

Releasing of spring-applied hydraulically released brake

- When energized, brake release solenoid valve (e) feeds oil from the charge circuit into the brake release ports of front motor (5), left-hand rear motor (7) and right-hand rear motor (9).
- Oil then flows into the cylinder built in brake unit (h). The piston inside the cylinder releases the brake against the compression spring force.

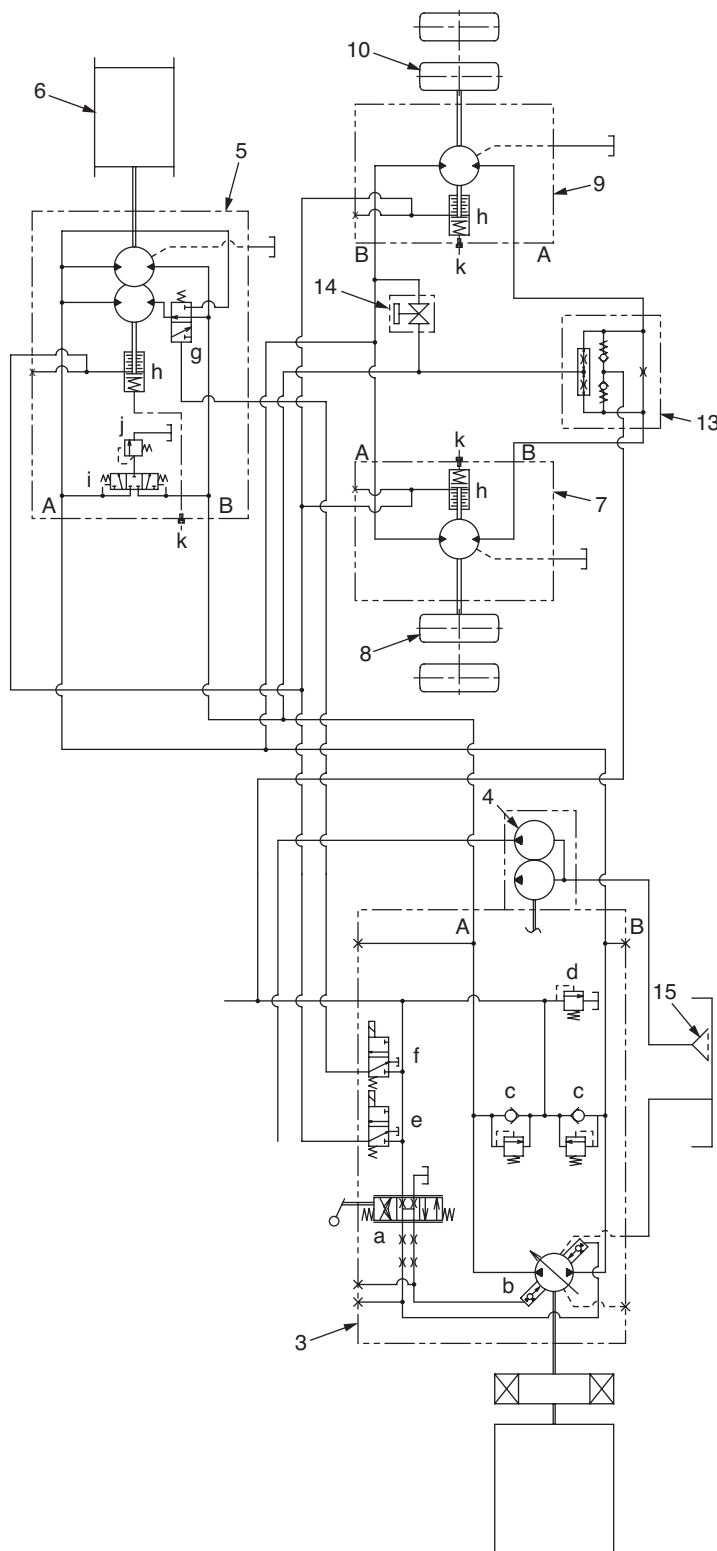

Speed selection

* See hydraulic circuit diagrams on pages 2-032 and 2-033.

- When speed selector solenoid valve (f) becomes energized, oil from the charge circuit is fed into the speed selection port of front propulsion motor (cam motor) (5) to actuate speed selector valve (g).
- With valve (g) actuated, oil that has been fed into six of twelve ports of distributor (11) while the machine is running at 'Low speed' changes its direction of flow to flow into three ports alone. This provides 'High speed'.

* See 'Description and operation of cam motor', page 2-023.

- Compared with the amount of hydraulic fluid required for the motor output shaft to make one turn at 'Low speed', the motor needs only half the amount if 'High Speed' is selected. This doubles the rotating speed of the motor output shaft. The pump is feeding constant quantity of fluid.
- Upon selecting 'High speed', the front motor runs faster, because amount of oil fed to the front motor per shaft rotation decreases, increasing the amount of oil to the rear motor to let it run faster. As a result, the whole motors gain speed so that the amount of oil needed for both the front and rear motors balance. At this time, they operate at their maximum speed according to the angular position of the pump swashplate.

★ Reversely, when shifting from 'High speed' to 'Low speed', the amount of fluid that the front propulsion motor draws per rotation is doubled.

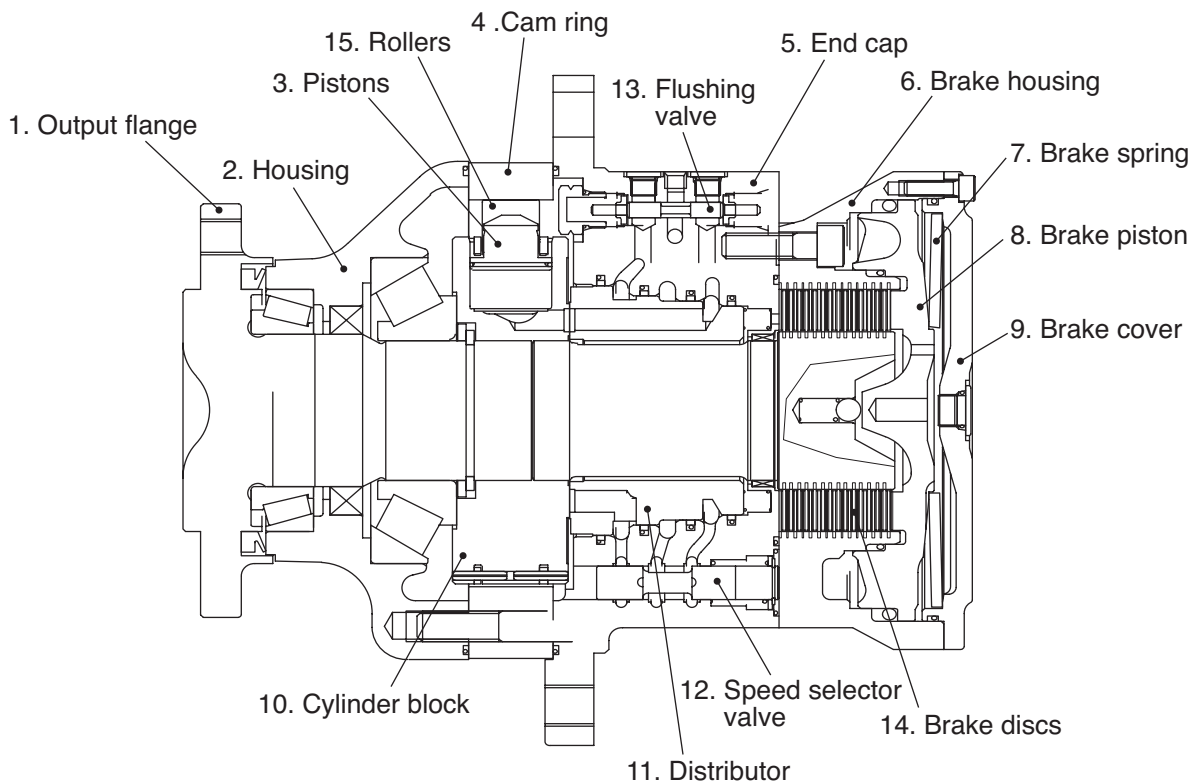

TW5022058

Circuit protection against excessive pressure

- Multi-function valve (c) fitted in the propulsion pump relieves the circuit pressure if it exceeds the setting of the valve, preventing damage to the circuit.

Charge circuit

- The propulsion circuit is of a closed loop circuit. To prevent negative pressure from building up in the low pressure line (pump inlet line) due to a leak in the high pressure line (pump outlet line), the charge check valve built in multi-function valve (c) feeds oil into the low pressure line to supply a deficiency.
- In the charge circuit, steering/charge pump (4) flow is fed into steering valve (Orbitrol) (11), then the full flow goes to propulsion pump (3) via line filter (12) irrespective of the steering wheel operation. When the F-R lever is in the neutral position, charge relief valve (d) opens to make the steering line lead to the tank. When travelling, the pressure in the high pressure line actuates flushing valve (i) so that the oil in the low pressure line leads to the tank through valves (i) and (j). To prevent charge relief valve (d) from opening while travelling, the pressure setting of valve (d) is set higher than that of valve (j).

Differential lock circuit (TW352, TW502)

- In normal travelling, differential function is automatically achieved by regulating the oil flow by means of the orifice provided inside differential lock valve (13).
- If rear wheels on one side begin skidding, differential lock valve (13) feeds more oil to the wheels on the other side which are not skidding.

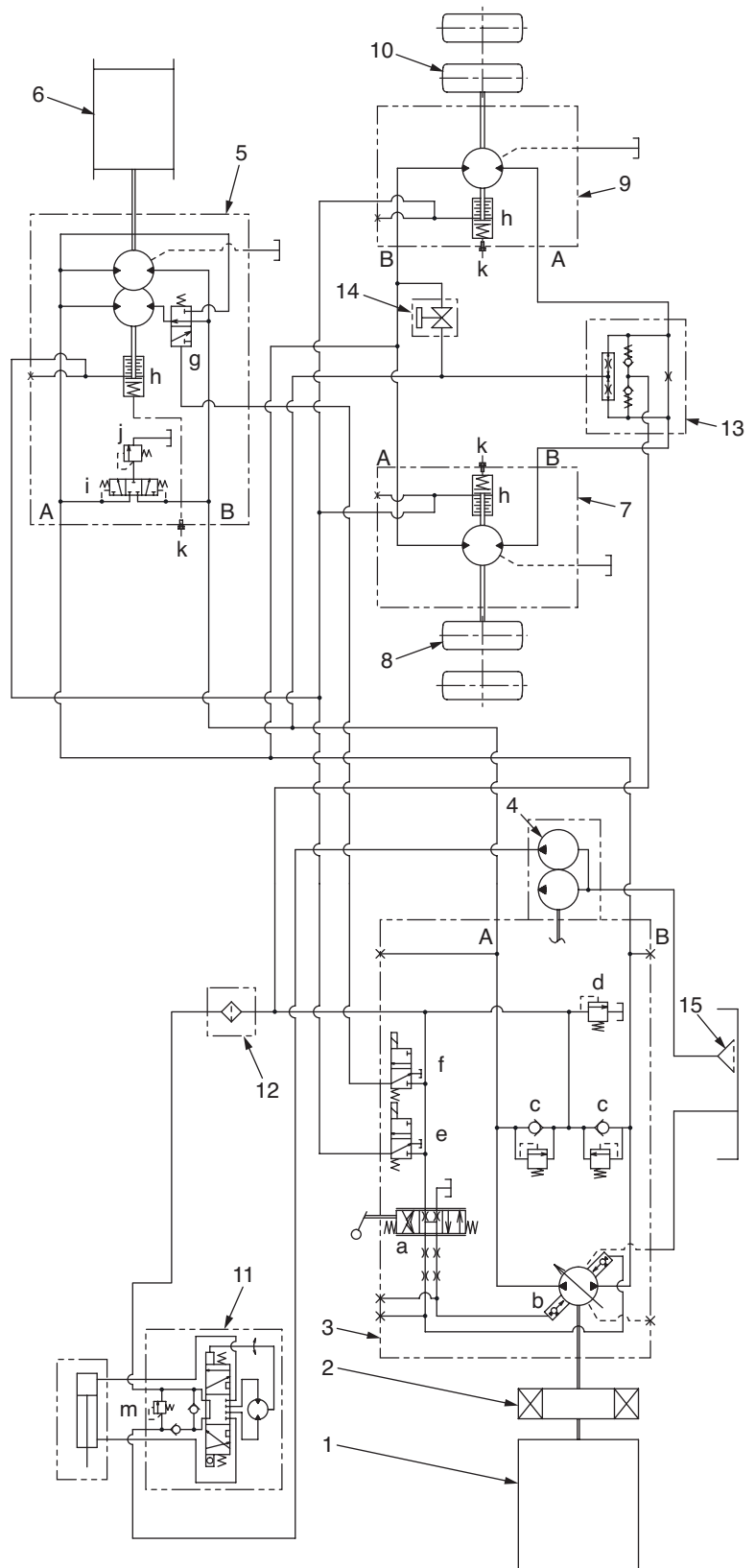

TW5022030

2-3. Vibrating system

2-3-1. Hydraulic piping (SW352)

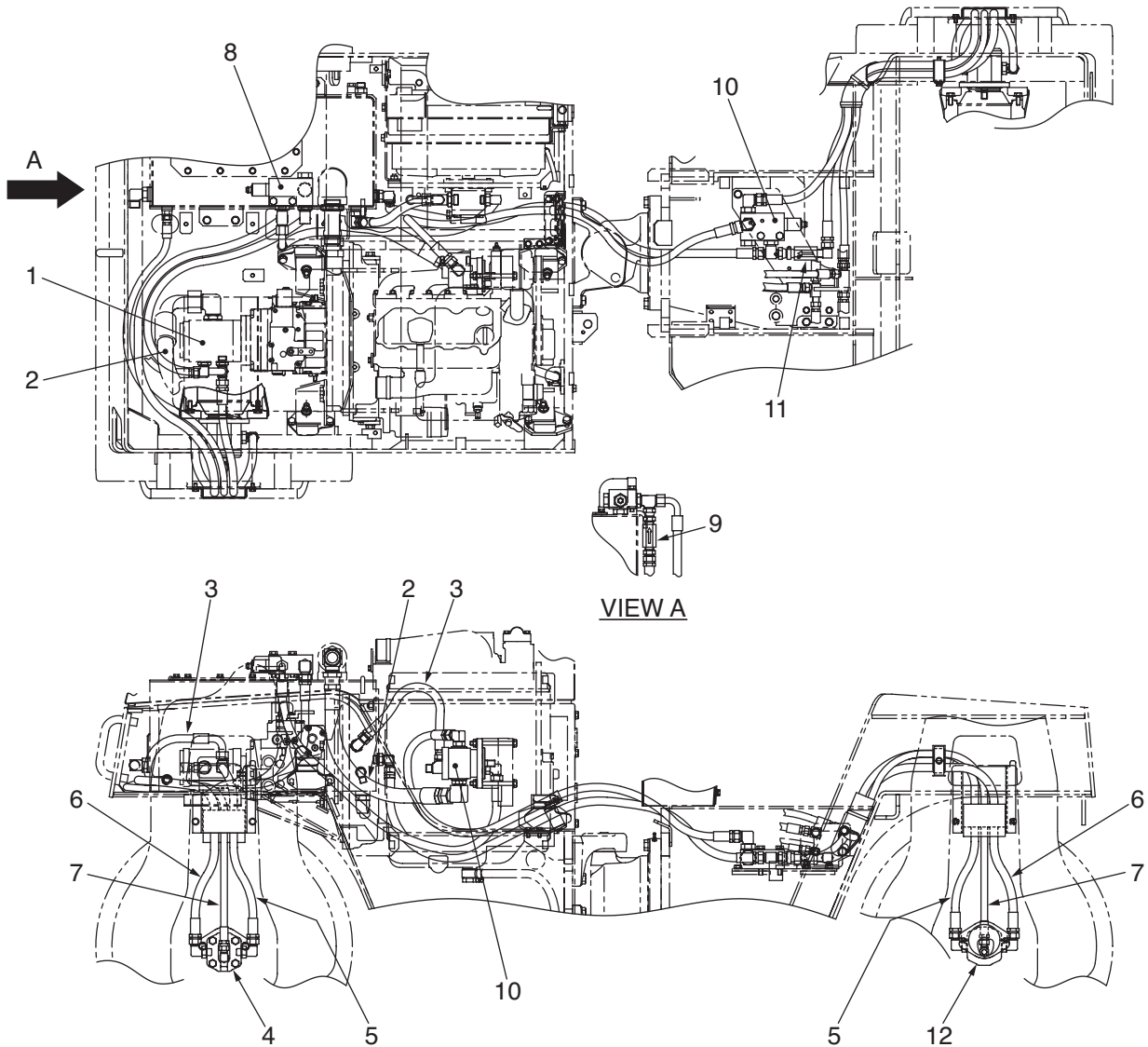

TW5022033

1. Front vibrator pump & steering/charge pump
 2. Suction hose
 3. Pump outlet hose
 4. Front vibrator motor

5. High pressure hose
 6. Return hose
 7. Drain hose
 8. Front vibrator on-off solenoid valve

9. Front check valve
 10. Rear vibrator on-off solenoid valve
 11. Rear charge valve
 12. Rear vibrator motor

2-3-2. Hydraulic piping (SW502)

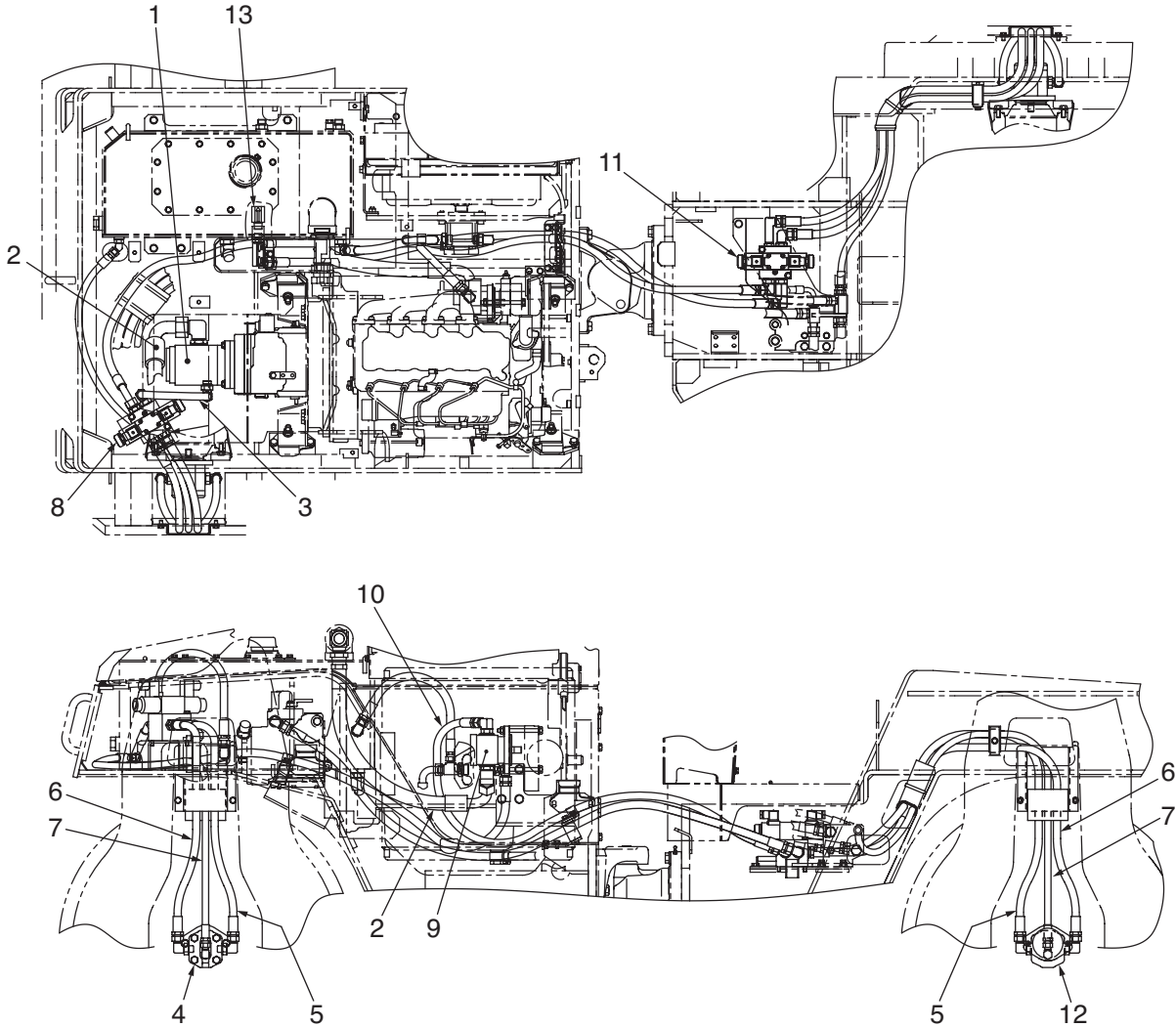

TW5022034

- 1. Front vibrator pump & steering/charge pump
- 2. Suction hose
- 3. Front pump outlet hose
- 4. Front vibrator motor
- 5. High pressure hose (high amp.)
- 6. High pressure hose (low amp.)
- 7. Drain hose
- 8. Front amplitude selector solenoid valve
- 9. Rear vibrator pump
- 10. Rear pump outlet hose
- 11. Rear amplitude selector solenoid valve
- 12. Rear vibrator motor
- 13. Check valve

2-3-3. Hydraulic piping (TW352)

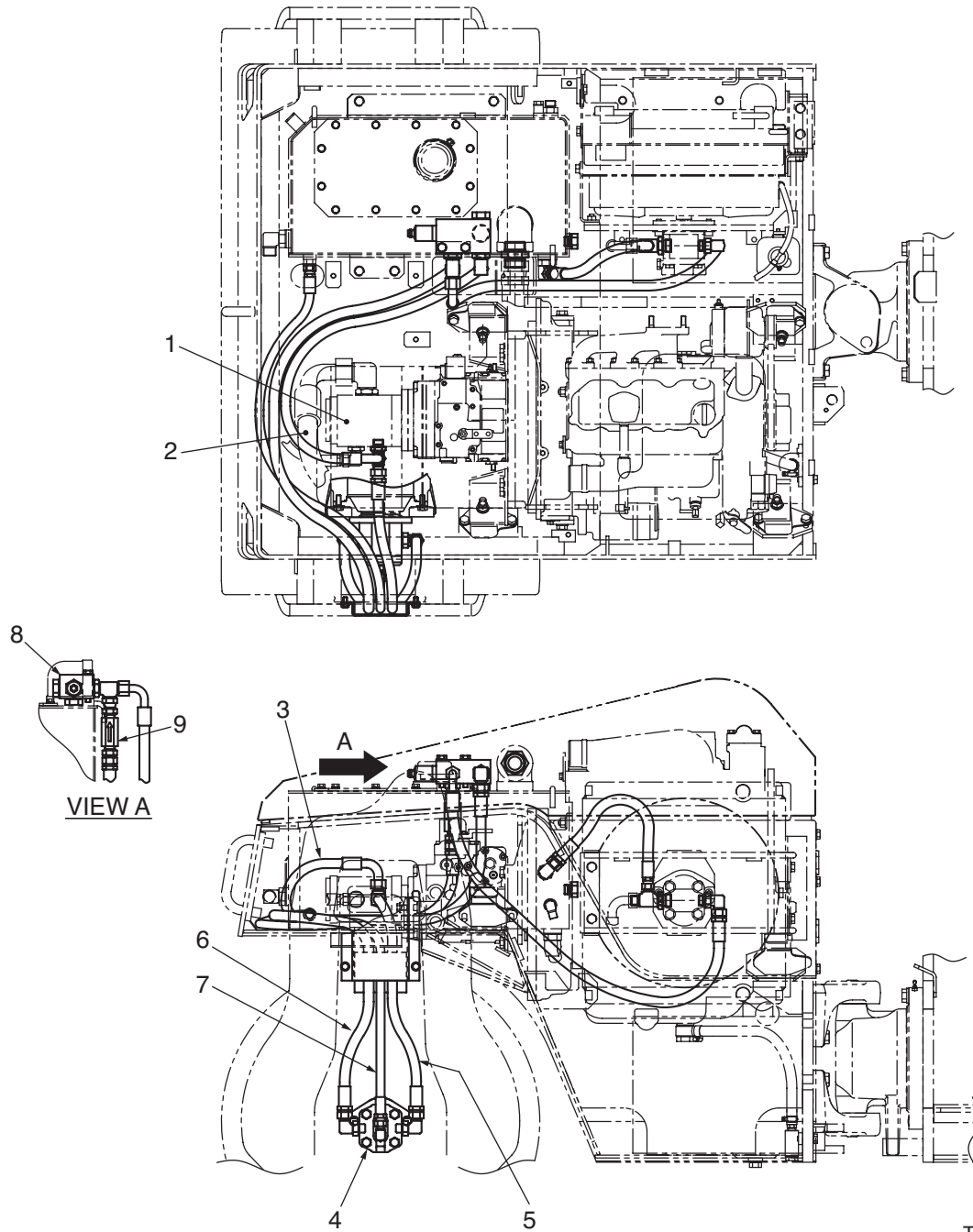

TW5022035

- | | |
|---|-----------------------------------|
| 1. Vibrator pump & steering/charge pump | 5. High pressure hose |
| 2. Suction hose | 6. Return hose |
| 3. Pump outlet hose | 7. Drain hose |
| 4. Vibrator motor | 8. Vibrator on-off solenoid valve |
| | 9. Check valve |

2-3-4. Hydraulic piping (TW502)

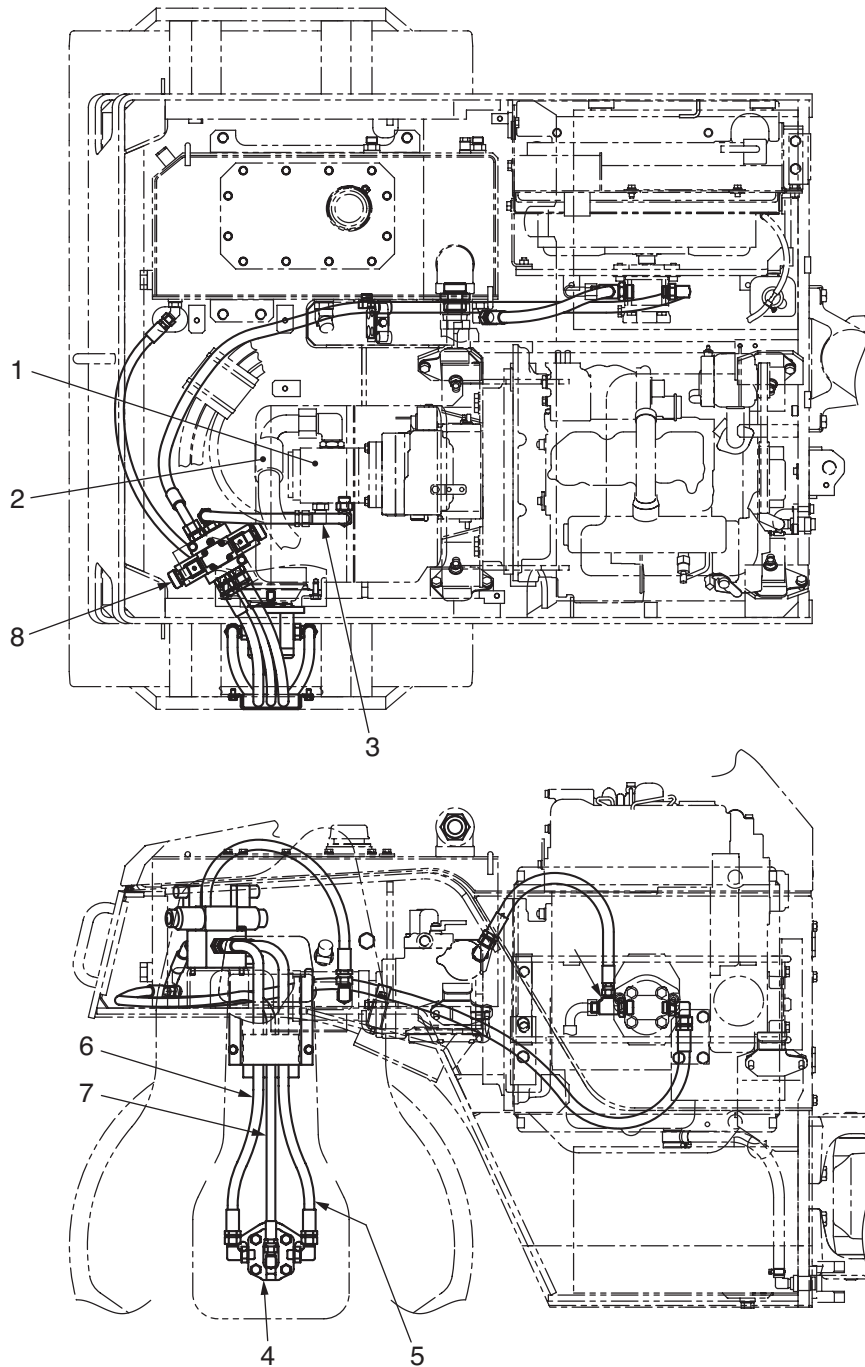

TW5022036

- | | |
|---|--------------------------------------|
| 1. Vibrator pump & steering/charge pump | 5. High pressure hose (high amp.) |
| 2. Suction hose | 6. High pressure hose (low amp.) |
| 3. Pump outlet hose | 7. Drain hose |
| 4. Vibrator motor | 8. Amplitude selector solenoid valve |

2-3-5. Vibrator motor assembly

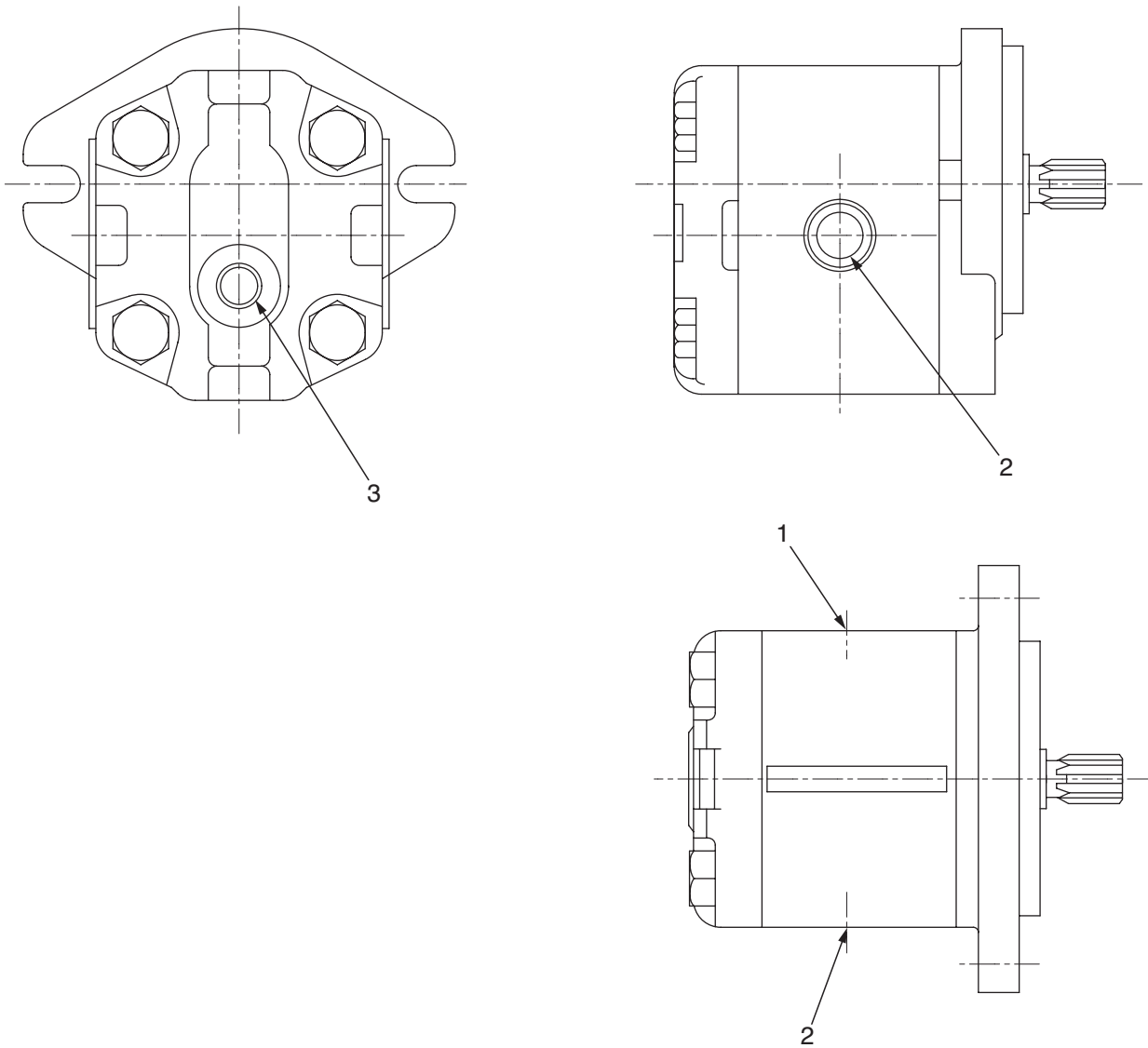

TW5022037

1. Port A (inlet/outlet port)
2. Port B (inlet/outlet port)
3. Drain port

Technical data

- Model: SNM2/11
- Displacement: 10.8 cm³/rev (0.7 cu.in/rev)
- Pressure setting: 12.7 MPa (130 kgf/cm²)
(SW352, TW352)
14.4 MPa (141 kgf/cm²)
(SW502, TW502)

2-3-6. Radiator fan motor assembly

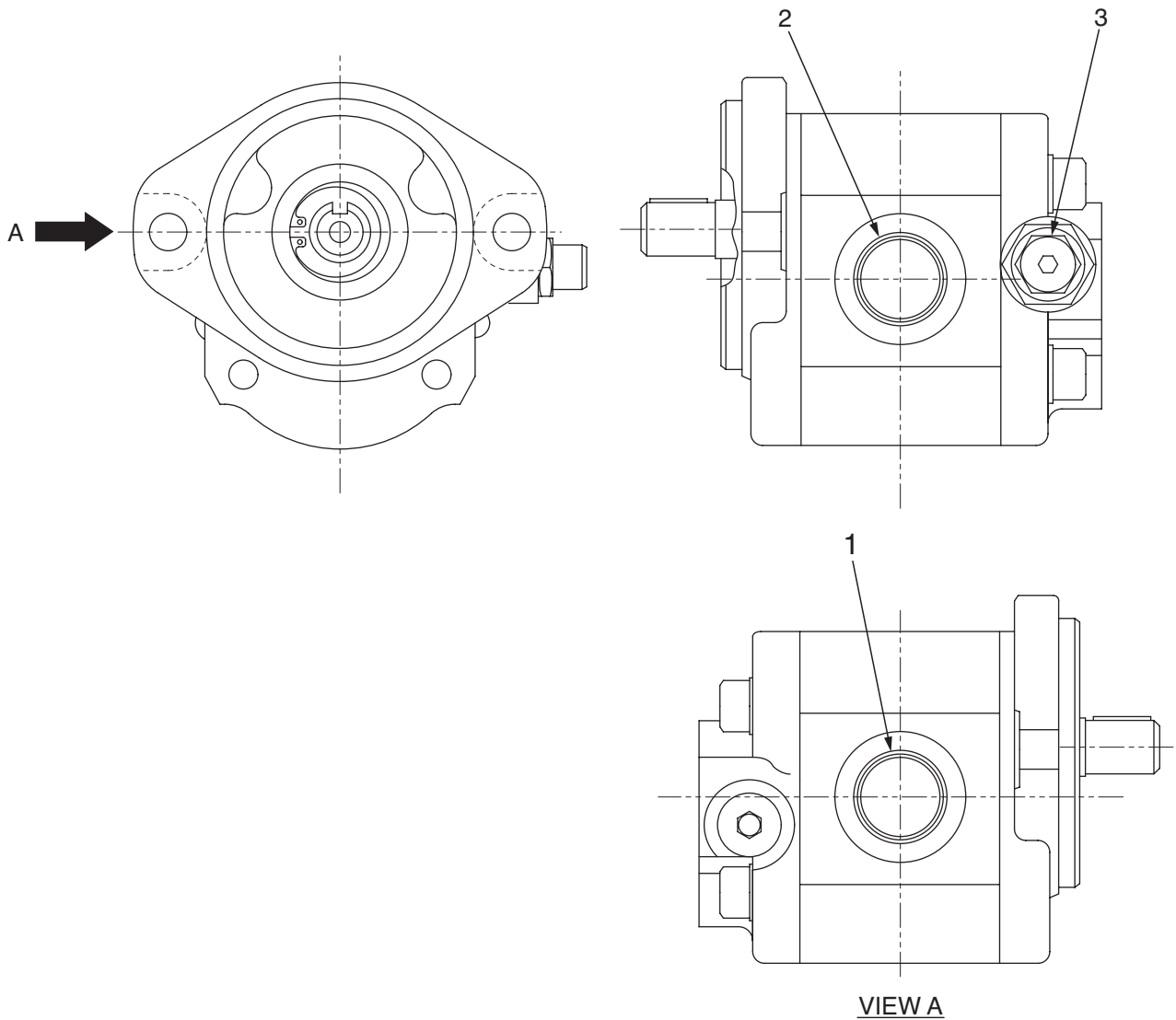

1. Inlet port
2. Outlet port
3. Pressure relief valve

Technical data

- Model: WM09A1C
- Displacement: 14.0 cm³/rev (0.9 cu.in/rev)
- Pressure setting: 5.0 MPa (51 kgf/cm²)

TW5022038

2-3-7. Vibrator (SW352, TW352)

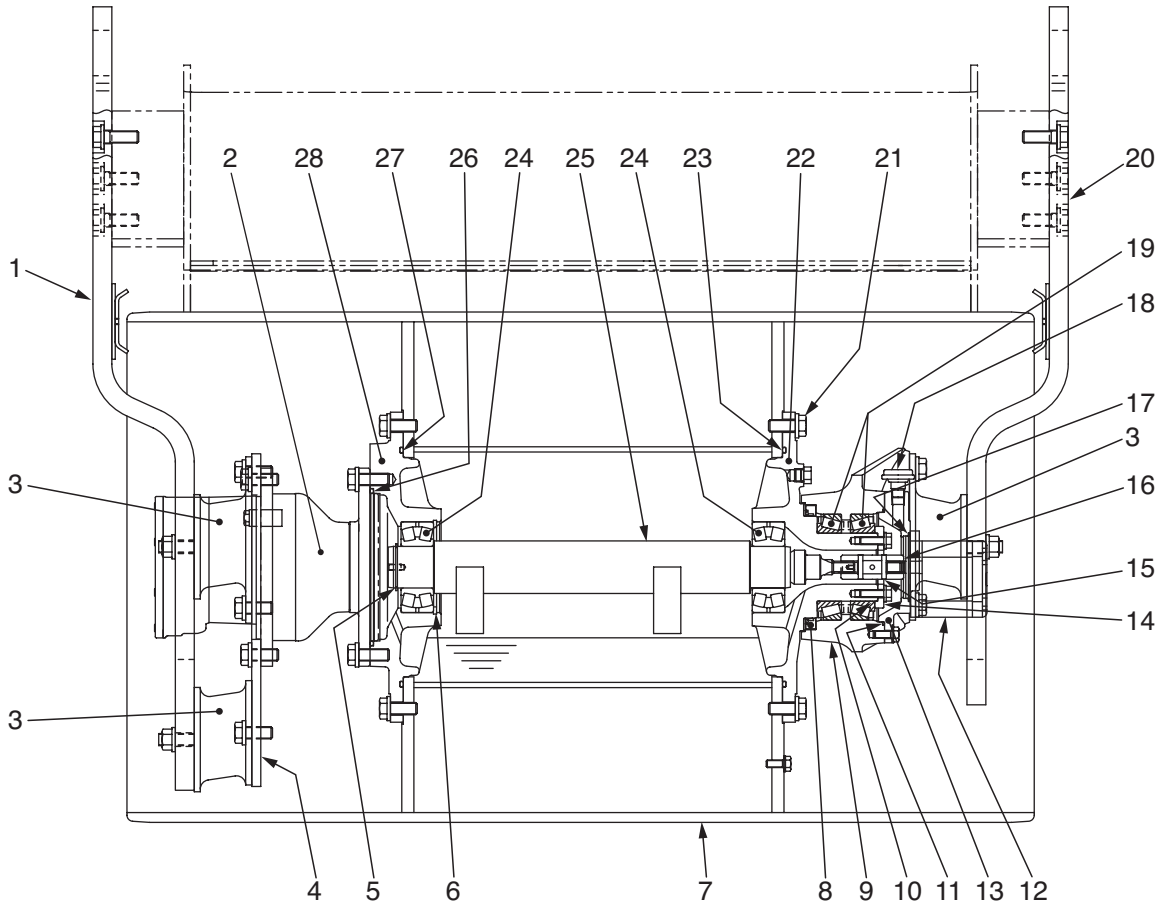

TW5022039

- | | | | |
|--------------------|--------------------|--------------------------|------------|
| 1. Side plate | 9. Disc | 17. O-ring | 25. O-ring |
| 2. Propulsor motor | 10. Shim | 18. Breather | 26. O-ring |
| 3. Shockmount | 11. O-ring | 19. Taper roller bearing | 27. O-ring |
| 4. Disc | 12. Vibrator motor | 20. Side plate | 28. Holder |
| 5. Lock ring | 13. Cover | 21. Plug | |
| 6. Lock ring | 14. Cover | 22. Boss | |
| 7. Drum | 15. Spring pin | 23. O-ring | |
| 8. Oil seal | 16. Sleeve | 24. Roller bearing | |

2-3-8. Vibrator (SW502, TW502)

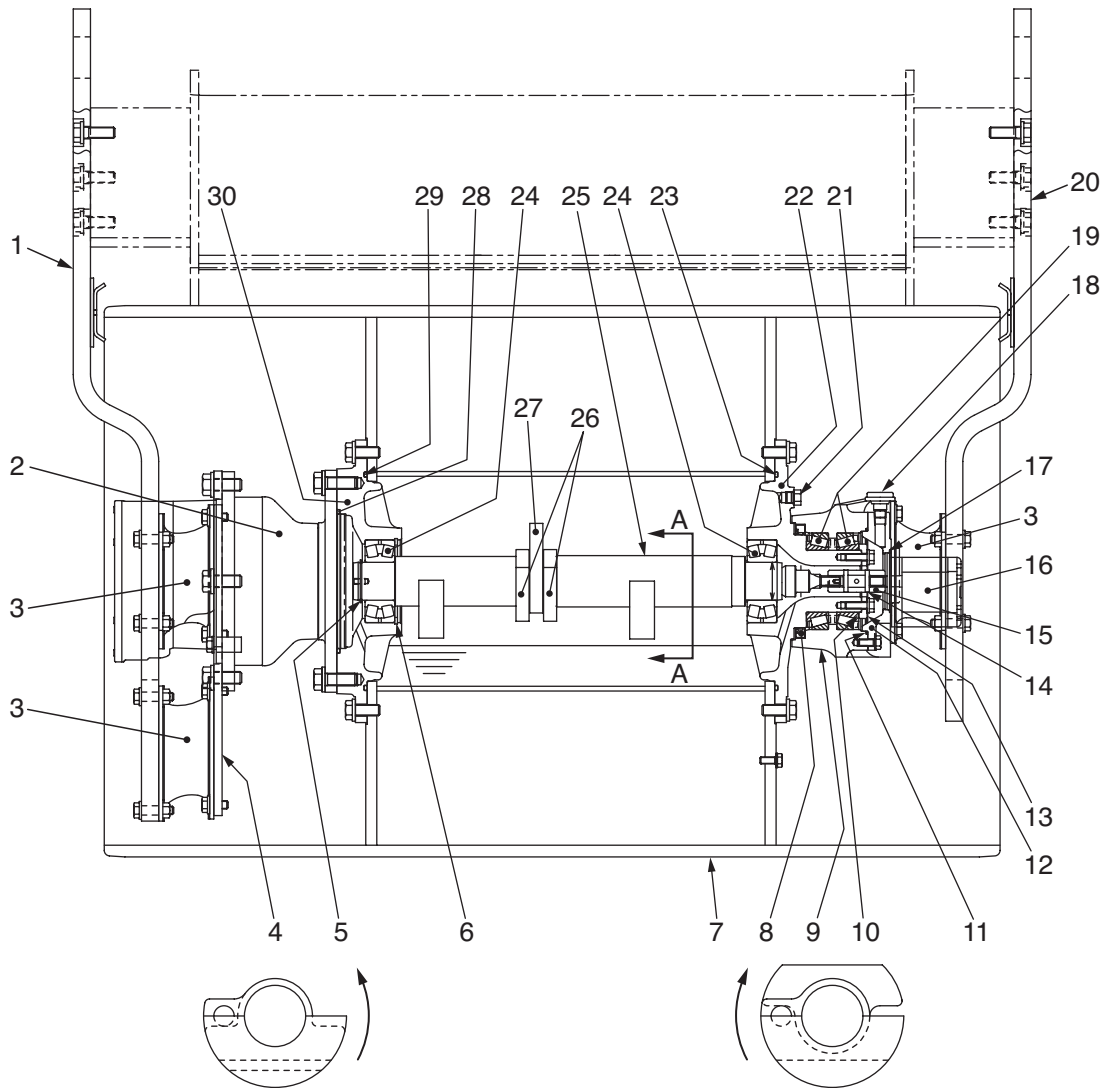

Counterclockwise rotation-High amp.

Clockwise rotation-Low amp.

SECTION A-A

TW5022040

- | | | | |
|---------------------|--------------------|--------------------------|--------------------|
| 1. Side plate | 9. Disc | 17. O-ring | 25. Shaft |
| 2. Propulsion motor | 10. Shim | 18. Breather | 26. Fixed weight |
| 3. Shockmount | 11. O-ring | 19. Taper roller bearing | 27. Movable weight |
| 4. Disc | 12. Cover | 20. Side plate | 28. O-ring |
| 5. Lock ring | 13. Cover | 21. Plug | 29. O-ring |
| 6. Lock ring | 14. Spring pin | 22. Boss | 30. Holder |
| 7. Drum | 15. Sleeve | 23. O-ring | |
| 8. Oil seal | 16. Vibrator motor | 24. Roller bearing | |

2-3-9. Vibrator circuit diagram (SW352, TW352)

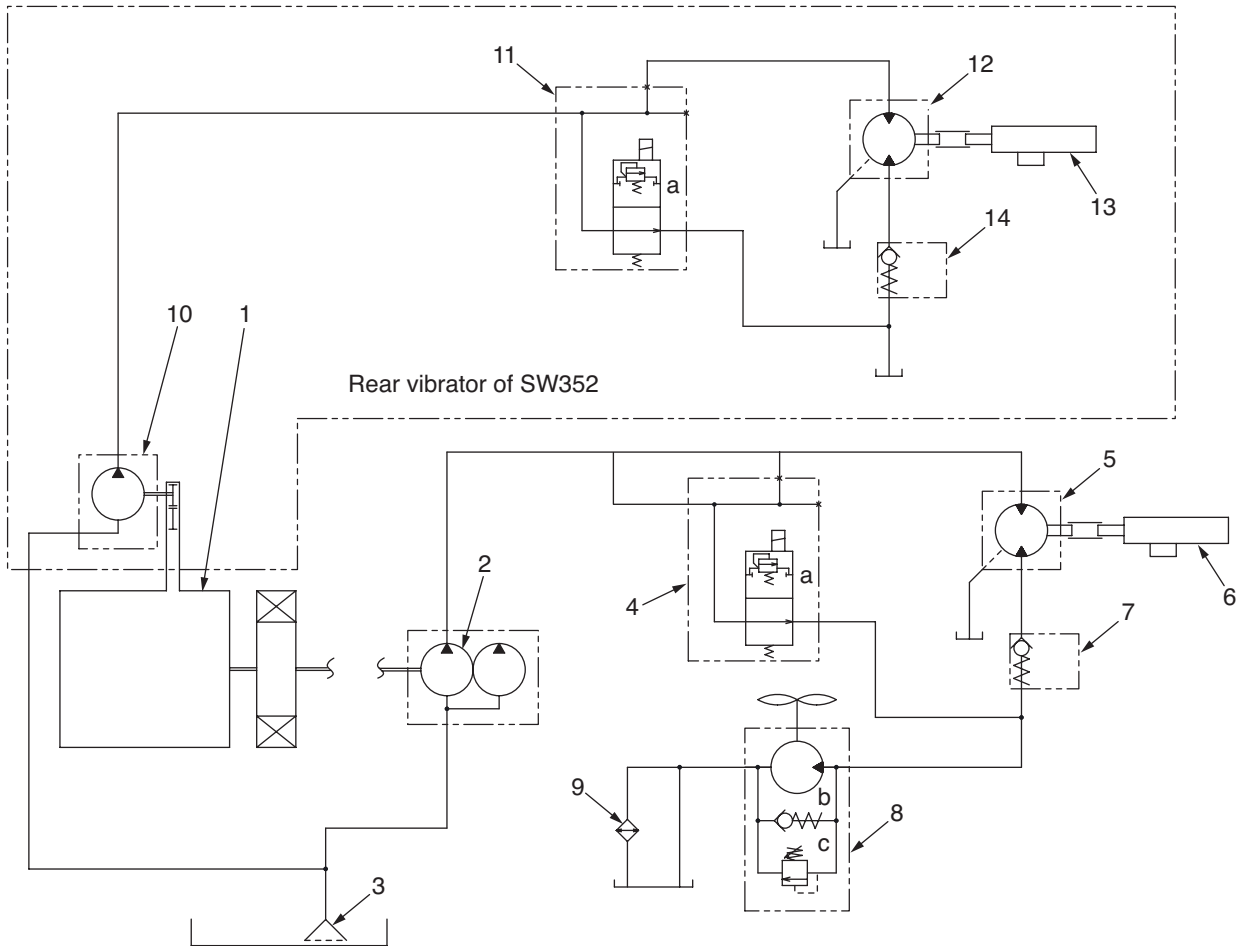

TW5022041

- | | |
|---|--|
| 1. Engine | 8. Radiator fan motor
(with check valve and relief valve) |
| 2. Vibrator pump | 9. Oil cooler |
| 3. Suction filter | 10. Rear vibrator pump |
| 4. Vibrator on-off solenoid valve
(with pressure relief valve) | 11. Vibrator on-off solenoid valve |
| 5. Front vibrator motor | 12. Rear vibrator motor |
| 6. Front vibrator | 13. Rear vibrator |
| 7. Check valve | 14. Check valve |

★ TW352 has vibrating unit in the front drum only.

2-3-10. Vibrator circuit diagram (SW502, TW502)

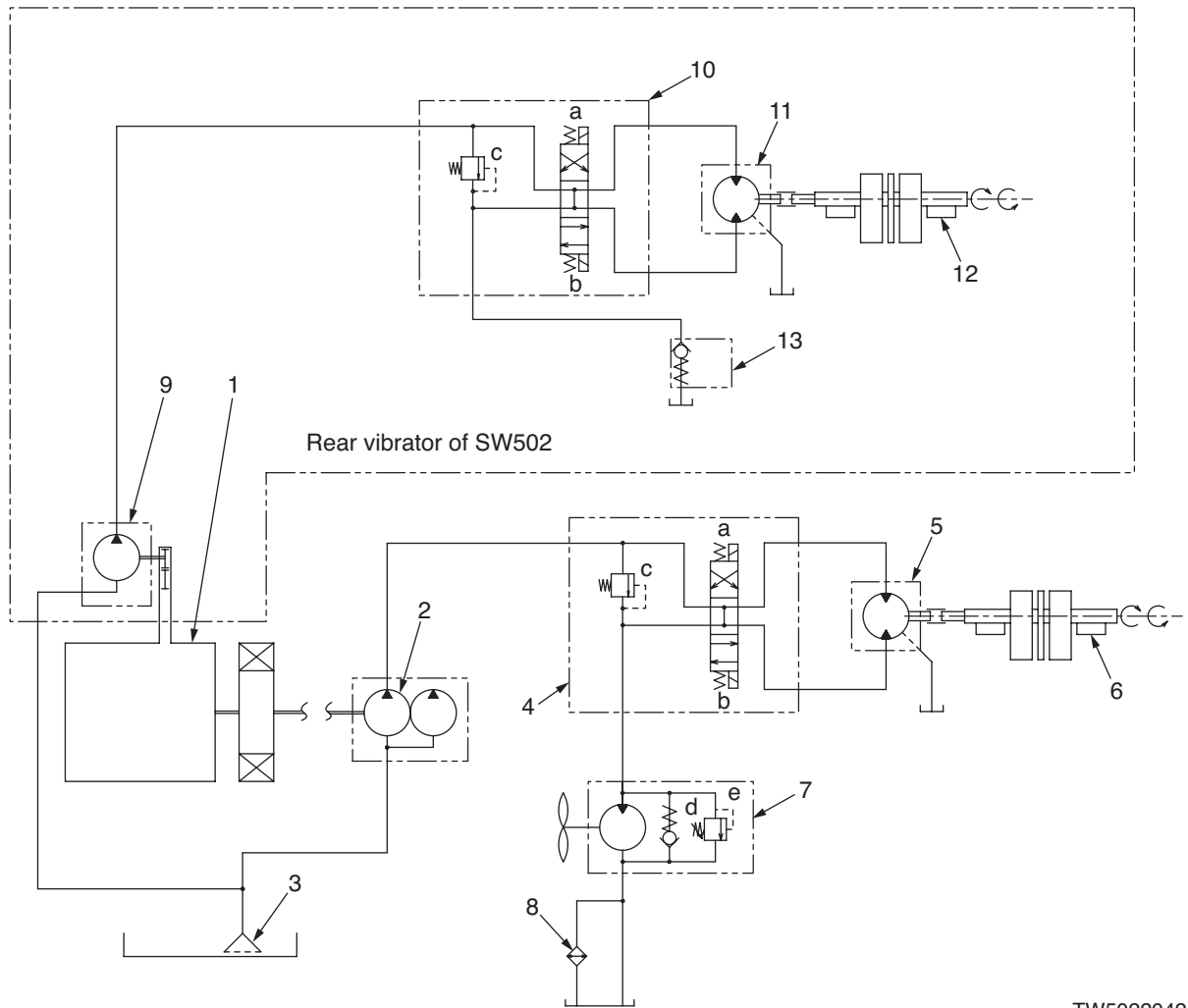

TW5022042

- | | |
|--|---|
| 1. Engine | 8. Oil cooler |
| 2. Front vibrator pump | 9. Rear vibrator pump |
| 3. Suction filter | 10. Amplitude selector solenoid valve
(with pressure relief valve) |
| 4. Amplitude selector solenoid valve
(with pressure relief valve) | 11. Rear vibrator motor |
| 5. Front vibrator motor | 12. Rear vibrator |
| 6. Front vibrator | 13. Check valve |
| 7. Radiator fan motor
(with check valve and relief valve) | |

★ TW502 has vibrating unit in the front drum only.

2-3-11. Description and operation of vibrating system

Description of vibrator circuit

SW352, TW352

* See hydraulic circuit diagrams on page 2-044.

- The front vibrator circuit comprises front vibrator pump (2), vibrator on-off solenoid valve (4), front vibrator motor (5), front vibrator (6), radiator fan motor (8) and oil cooler (9). Vibrator on-off solenoid valve (4) has pressure relief valve (a) in it, while check valve (b) and pressure relief valve (c) are built into the radiator fan motor.

The rear vibrator circuit consists of rear vibrator pump (10), vibrator on-off solenoid valve (11), rear vibrator motor (12), rear vibrator (13) and check valve (14). Vibrator on-off solenoid valve (11) has built-in pressure relief valve (a).

★ TW352 has front vibrating unit alone.

SW502, TW502

* See hydraulic circuit diagrams on page 2-045.

- The front vibrator circuit is made up of front vibrator pump (2), amplitude selector solenoid valve (4), front vibrator motor (5), front vibrator (6), radiator fan motor (7) and oil cooler (8). Pressure relief valve (c) is built into amplitude selector solenoid valve (4), while radiator fan motor (7) has check valve (d) and pressure relief valve (e).
- The rear vibrator circuit consists of rear vibrator pump (9), amplitude selector solenoid valve (10), rear vibrator motor (11), rear vibrator (12) and check valve (13). Amplitude selector solenoid valve (10) has pressure relief valve (c) built in it.

★ TW502 has front vibrator alone.

Fundamental function of vibrator pump and vibrator motor.

Vibrator pump

- A gear pump is employed. Its delivery per shaft rotation remains constant.

Vibrator motor

- Same type as the vibrator pump.

Operation

SW352, TW352 (front vibrator)

* See hydraulic circuit diagrams on page 2-044.

- Vibrator pump (2) feeds oil all the time that the engine is running. When the vibrator is not in use, oil is fed to radiator fan motor (8) via vibrator on-off solenoid valve (4) to drive it and then exhausted to the tank either through the oil cooler or directly.
- With the vibrator switch ON, vibrator on-off solenoid valve (4) blocks the line to radiator fan motor (8) to operate vibrator motor (5). Then the vibrator motor flow is fed to radiator fan motor (8) via check valve (7) and exhausted to the tank either directly or through the oil cooler.

SW352 (rear vibrator)

*** See hydraulic circuit diagrams on page 2-044.**

- Being a gear pump, rear vibrator pmp (2) discharges oil as long as it is driven. When the vibrator is not in use, it is unloaded by vibrator on-off solenoid valve (11).
- With the vibrator on-off switch ON, vibrator on-off solenoid valve (11) closes the unload circuit, making the vibrator circuit energize. The oil under pressure drives vibrator motor (gear motor) (12), and then flows back to the tank.

SW502, TW502 (front vibrator)

*** See hydraulic circuit diagrams on page 2-045.**

- Because vibrator pump (2) is a gear pump, it continues discharging oil as long as it is driven. With amplitude selector solenoid valve (4) in the neutral position (all ports open), the pump is put under no load. Oil in the unload circuit or oil displaced from vibrator motor (5) is fed into radiator fan motor (7) circuit to drive radiator fan motor (7). Then oil is drained to the tank either directly or via oil cooler (8).
- Energizing of amplitude selector solenoid (a) or (b) selects Low amplitude or High amplitude respectively by reversing rotating direction of gear motor (5).

★ A choice of amplitude is made as follows:

- Oil drawn from port B of gear motor (5) → High amplitude
- Oil drawn from port A of gear motor (5) → Low amplitude

SW502 (rear vibrator)

*** See hydraulic circuit diagrams on page 2-045.**

- Operation is same as the front vibrator except for the return line. Oil displaced from vibrator motor (11) returns to the tank through check valve (13).

Protection of vibrator circuit from excessive pressure

SW352, TW352

*** See hydraulic circuit diagrams on page 2-044.**

- Pressure relief valves (a) built in vibrator on-off solenoid valves (4) and (11) vent the pressure to the tank if it exceeds the preselected setting of the valve.

SW502, TW502

*** See hydraulic circuit diagrams on page 2-045.**

- Pressure relief valves (c) built in amplitude selector solenoid valves (4) and (10) relieve the pressure if it exceeds the setting of the valve.

Protection of radiator fan motor circuit from excessive pressure

- Pressure relief valve (e) in the radiator fan motor relieves the pressure in this line if it exceeds the setting of the valve.

2-4. Steering system

2-4-1. Hydraulic piping

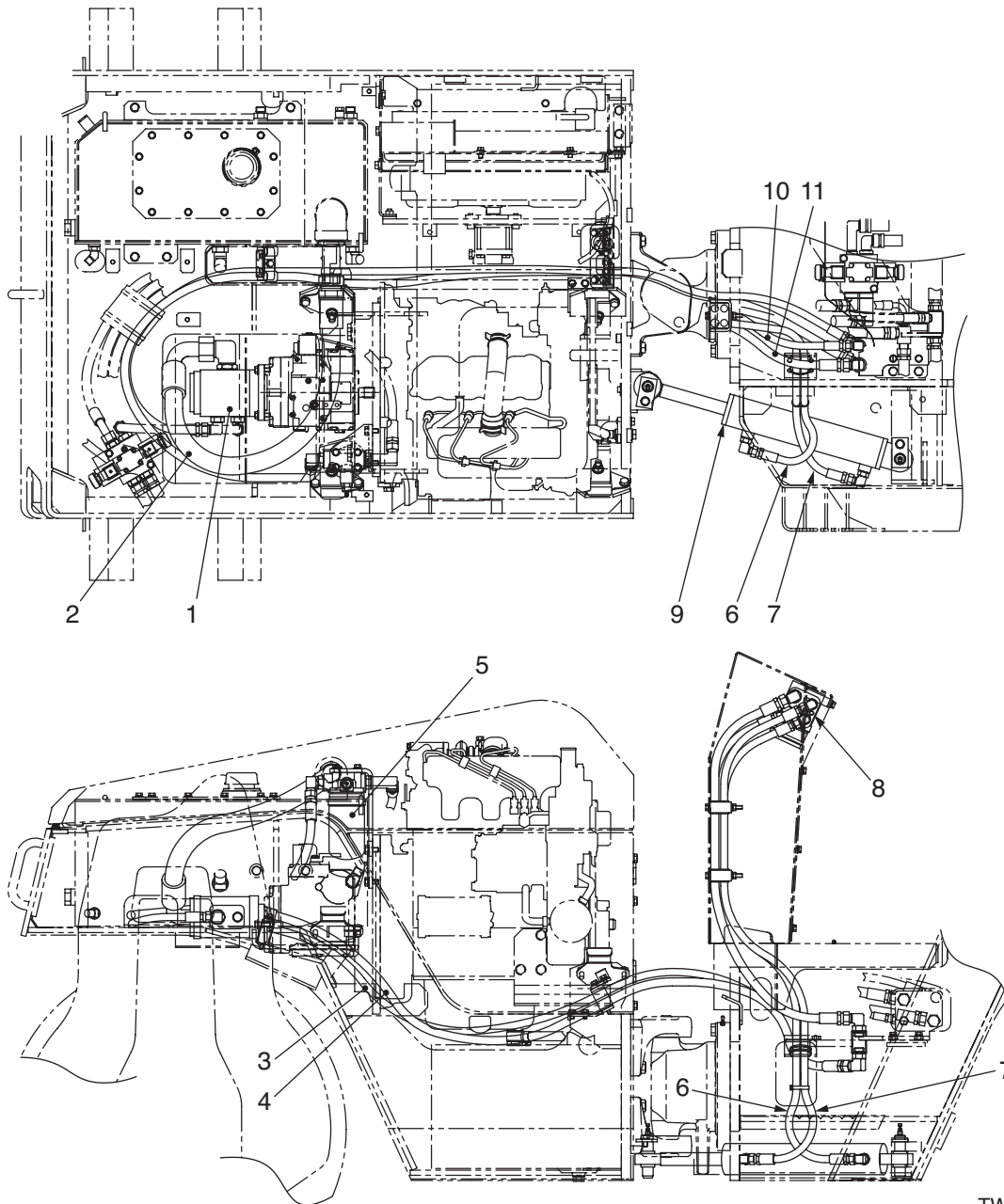

TW5022043

- | | |
|------------------------------------|-----------------------------------|
| 1. Steering/charge pump | 7. High pressure hose (left turn) |
| 2. Suction hose | 8. Steering valve (Orbitrol) |
| 3. Pump outlet hose (1) | 9. Steering cylinder |
| 4. Charge circuit hose (1) | 10. Pump outlet hose (2) |
| 5. Line filter (charge circuit) | 11. Charge circuit hose (2) |
| 6. High pressure hose (right turn) | |

2-4-2. Steering valve (Orbitrol)

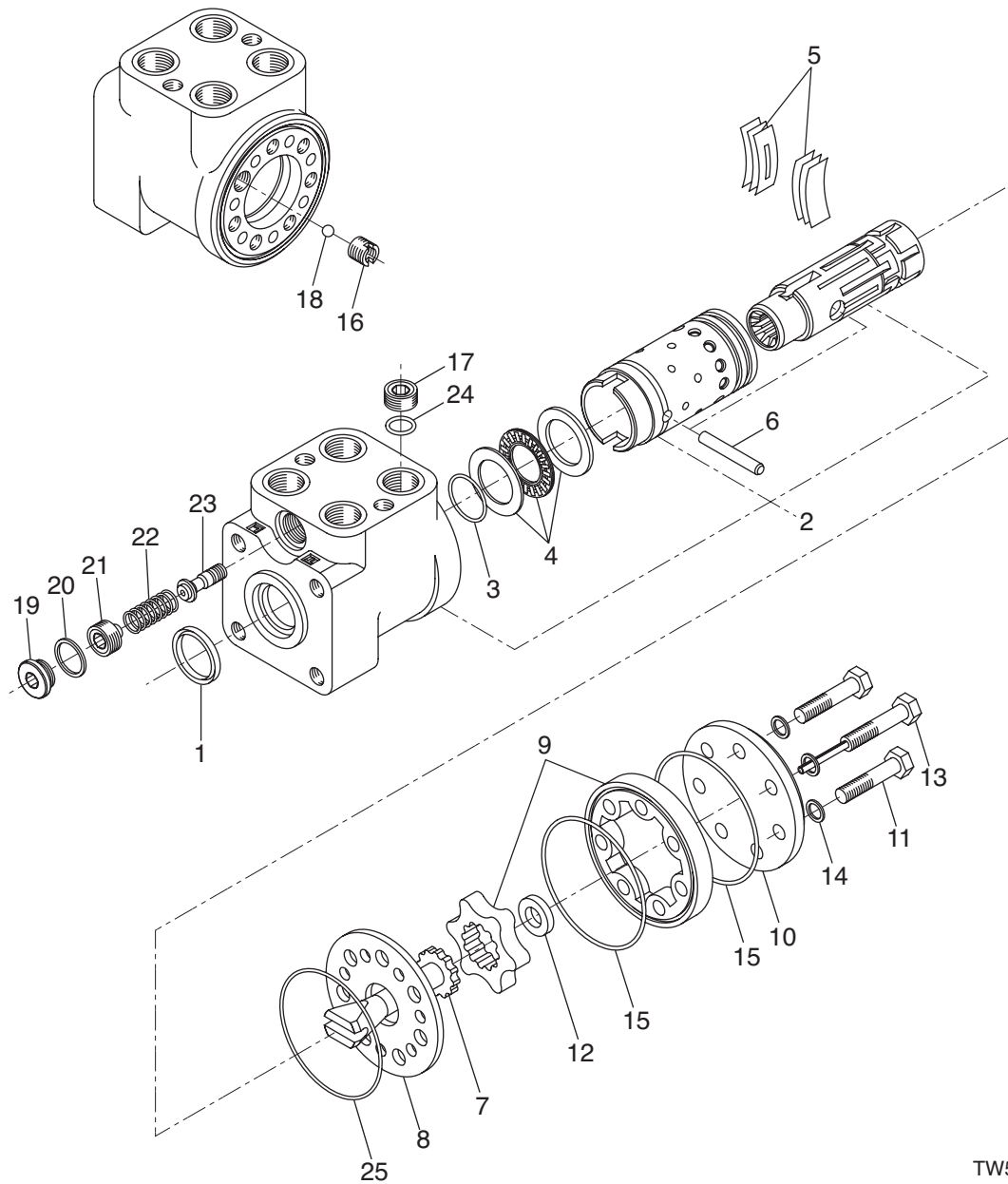

TW5022044

- | | | | |
|----------------------------------|-----------------|------------|-------------|
| 1. Dust seal ring | 10. End cover | 20. Washer | 23. Plunger |
| 2. Housing/spool/sleeve assembly | 11. Bolt | 21. Plug | 24. O-ring |
| 3. O-ring | 12. Spacer | 22. Spring | 25. O-ring |
| 4. Bearing assembly | 13. Bolt | | |
| 5. Spring | 14. Washer | | |
| 6. Cross pin | 15. O-ring | | |
| 7. Drive | 16. Bush | | |
| 8. Distributor plate | 17. Check valve | | |
| 9. Gerotor set | 18. Ball | | |
| | 19. Plug | | |

Technical data

- Valve system: Open center non-load reaction
- Displacement: 100 cm³/rev (6.1 cu.in/rev) (SW352, TW352)
160 cm³/rev (9.8 cu.in/rev) (SW502, TW502)
- Relief valve setting: 13.5 MPa (138 kgf/cm²)

2-4-3. Steering cylinder assembly

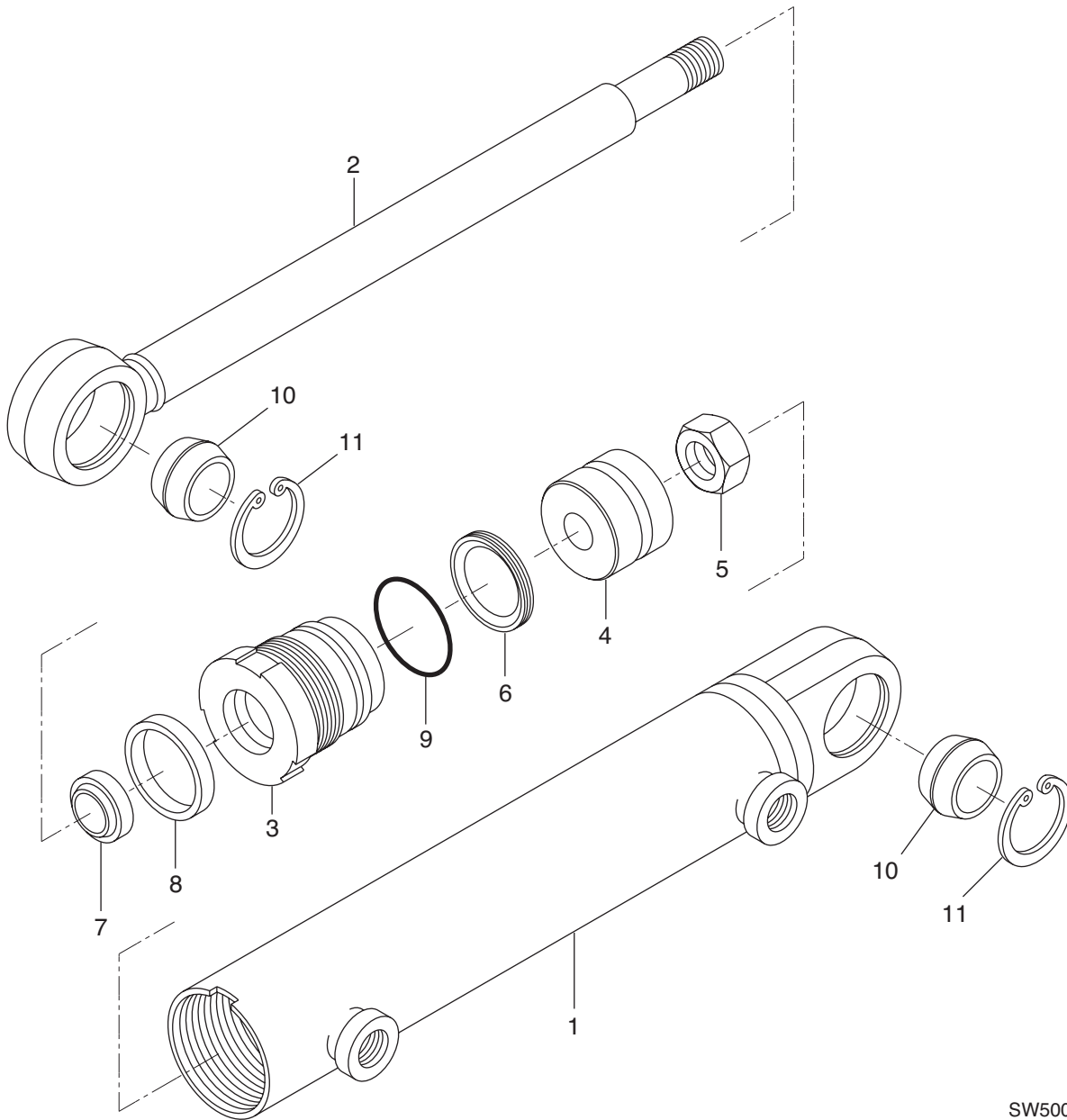

SW5002040

- 1. Cylinder
- 2. Piston rod
- 3. End cap
- 4. Piston

- 5. Nut
- 6. Seal
- 7. Dust seal
- 8. U-ring

- 9. O-ring
- 10. Spherical bearing
- 11. Lock ring

2-4-4. Steering circuit diagram

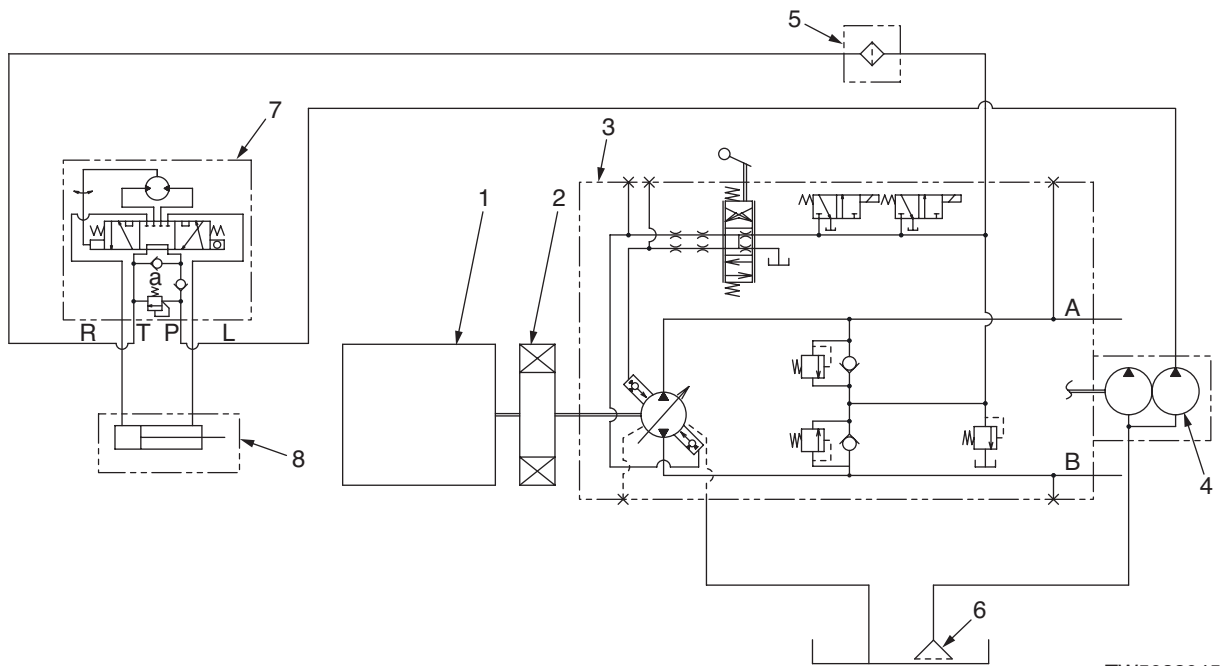

TW5022045

- | | |
|-------------------------|------------------------------|
| 1. Engine | 6. Suction filter |
| 2. Coupling | 7. Steering valve (Orbitrol) |
| 3. Propulsion pump | a. Relief valve |
| 4. Steering/charge pump | 8. Steering cylinder |
| 5. Line filter | |

2-4-5. Description and operation of steering circuit

Description

- The steering system consists of steering/charge pump (4), line filter (5), steering valve (Orbitrol) (7) and steering cylinder (8). The steering mechanism is of an articulated type in which the machine frame is articulated at its center.

Operation

- Oil from gear pump (4) enters steering valve (7). Then the valve feeds an amount of oil into cylinder (8) in accordance with the direction and speed in and at which the steering wheel is rotated.
- The steering fluid fed into steering cylinder (8) moves the piston rod to achieve steering. The fluid displaced from the opposite side of the piston flows, through steering valve (7) and line filter (5), to the charge circuit of the propulsion pump.
- Relief valve (a) built in steering valve (7) opens to vent the excessive pressure to the tank if it exceeds the setting of the relief valve, thus preventing damage to the steering system.

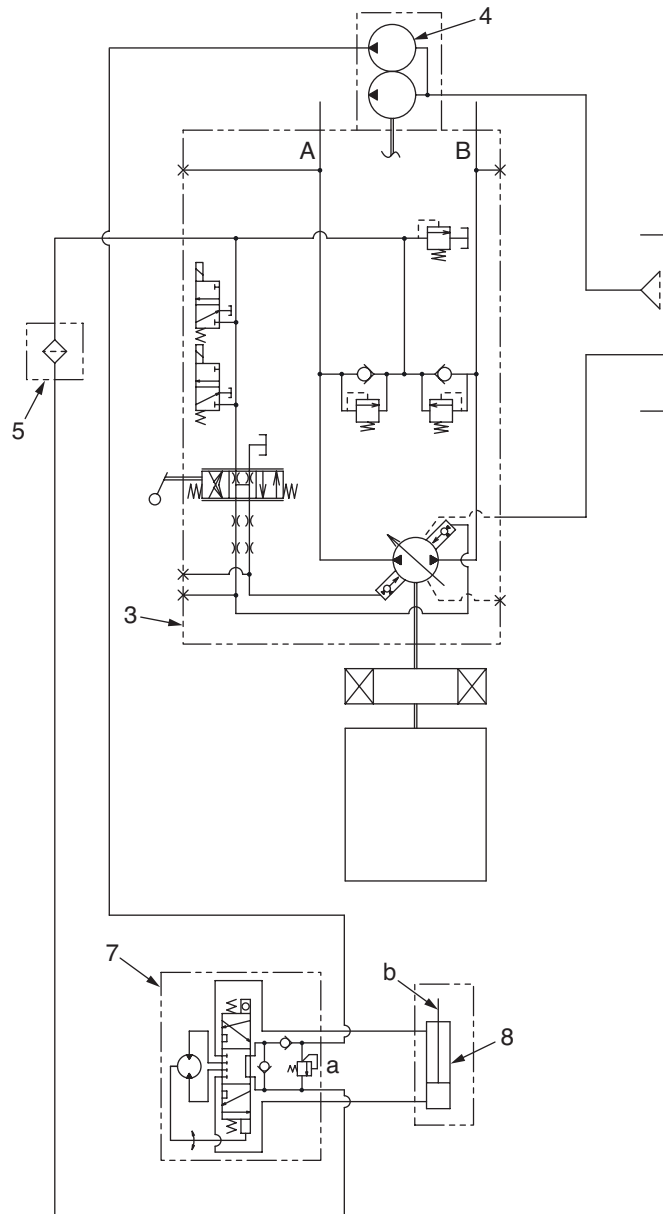

TW5022046

3. Brake System

3-1. Brake pedal

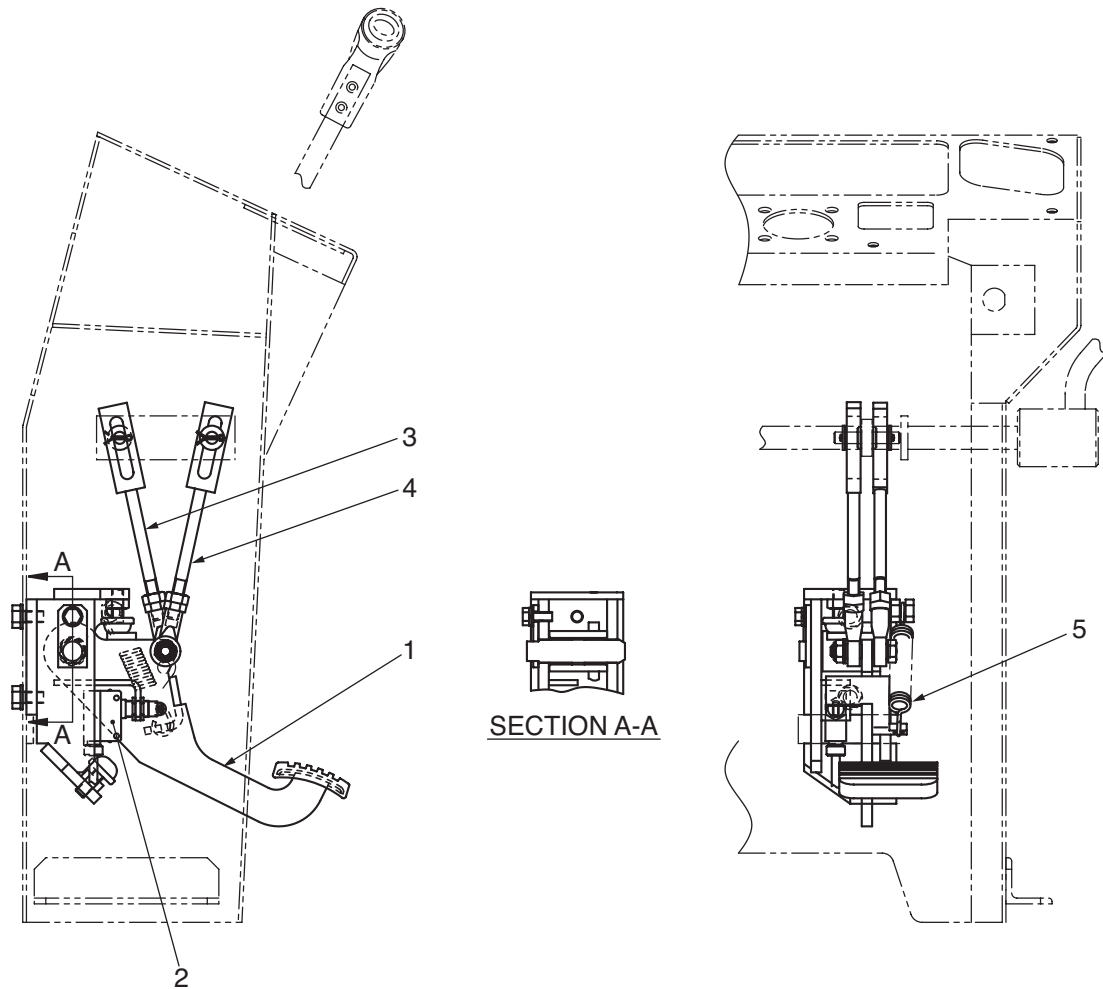

1. Brake pedal
2. Brake pedal switch
3. F-R lever rod (centering rod)
4. F-R lever rod (centering rod)
5. Spring

TW5022047

3-2. Description and operation of parking brake (negative brake) circuit

Description

- Consists of brake pedal (1), foot brake switch (2), centering rods (3), (4), parking brake switch (5), F-R lever (6), brake release solenoid valve (7), parking brakes (negative brakes) (8), (9), (10) and brake lamp relay (11).

Operation

Parking brake switch set to PARKING position

- The contact points of parking brake switch (5) open the circuit to the brake release solenoid valve (7) and energizes the indicator lamp circuit.
- The indicator lamp comes on. The parking brakes (8), (9) and (10) are applied.

★ **The brake release solenoid valve becomes deenergized.**

Parking brake switch set to RELEASE position.

- The contact points of parking brake switch (5) close the circuit to the brake release solenoid valve (7) and open the brake indicator lamp circuit.
- The indicator lamp comes off. Parking brakes (8), (9) and (10) are released.

★ **The brake release solenoid valve is energized.**

Braking in an emergency

- Depressing brake pedal (1) as far as it will go breaks the contact points of foot brake switch (2), opening the circuit of brake release solenoid. At the same time, the pedal movement moves either centering rod (3) or (4) to bring the F-R lever to the neutral position. This deenergizes the brake release solenoid circuit to apply the parking brake (negative brake) by means of the compression spring load. Dynamic braking takes place.

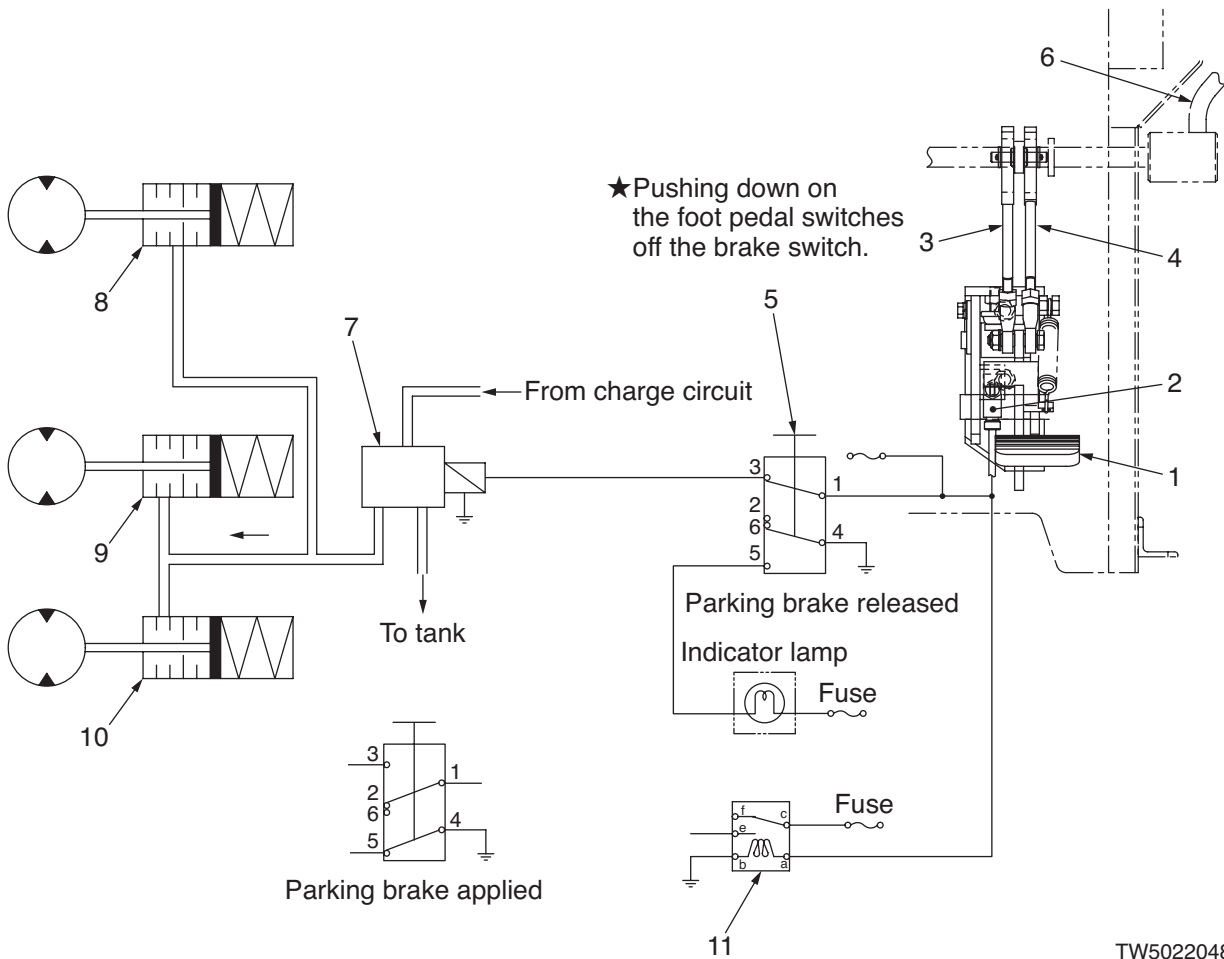

TW5022048

★ The schematic drawing above is the circuit of TW352 and TW502.

4. Sprinkler

4-1. Sprinkler piping

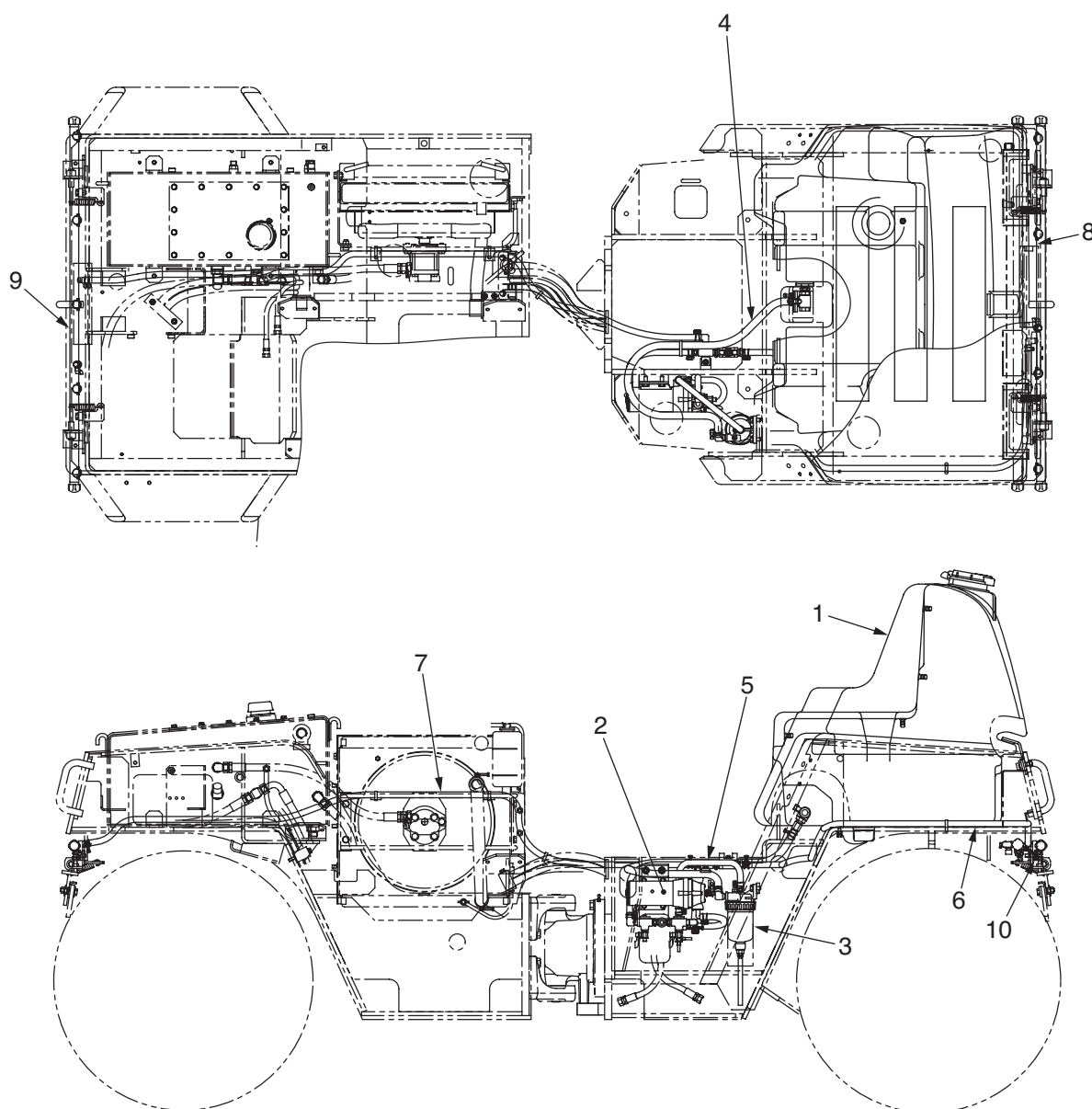

TW5022049

1. Sprinkler tank
2. Sprinkler pump
3. Sprinkler filter
4. Hose (tank to filter)
5. Hose (filter to pump)

6. Hose (pump to rear pipe)
7. Hose (pump to front pipe)
8. Sprinkler pipe (rear)
9. Sprinkler pipe (front)
10. Sprinkler nozzle

5. Liquid Sprayer

5-1. Liquid sprayer piping

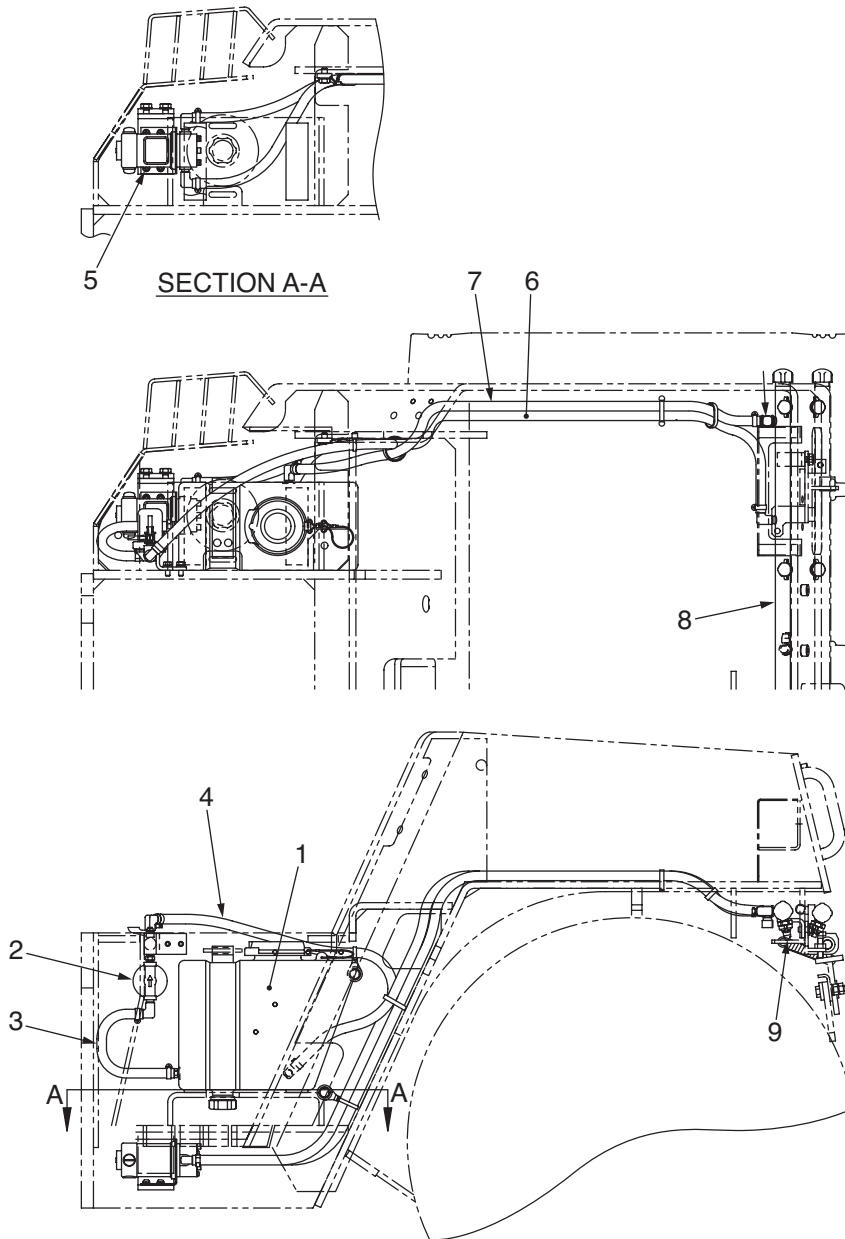

1. Liquid tank
2. Liquid filter
3. Hose (tank to filter)
4. Hose (filter to pump)
5. Liquid spray pump

6. Hose (pump to pipe)
7. Hose (pipe to pump)
8. Liquid pipe
9. Liquid nozzle

TW5022050

★ Above illustrations represent liquid spray system for TW352 and TW502.

6. Electric System

6-1. Location of instrument panel and key units

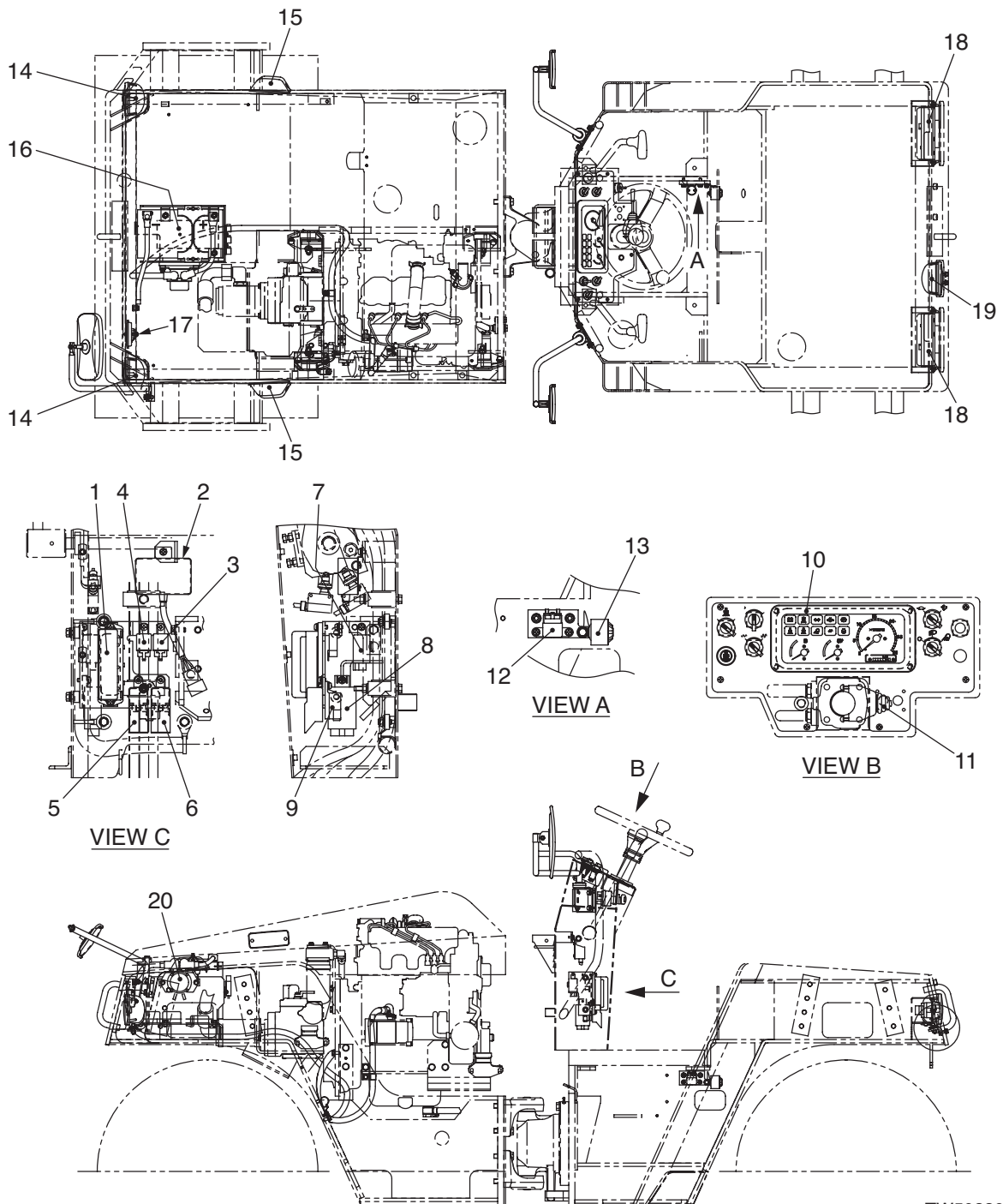

TW5022051

- | | | |
|------------------------|------------------------|----------------------|
| 1. Fuse box | 8. Vibrator relay | 15. Turn signal lamp |
| 2. Control box | 9. Glow lamp timer | 16. Battery |
| 3. Horn relay | 10. Combination meter | 17. Horn |
| 4. Vibrator lamp relay | 11. Turn signal switch | 18. Combination lamp |
| 5. Interlock relay | 12. Sprinkler relay | 19. Work lamp |
| 6. Brake lamp relay | 13. Reverse alarm | 20. Battery relay |
| 7. Flasher unit | 14. Head lamp | |

6-2. Location of key units

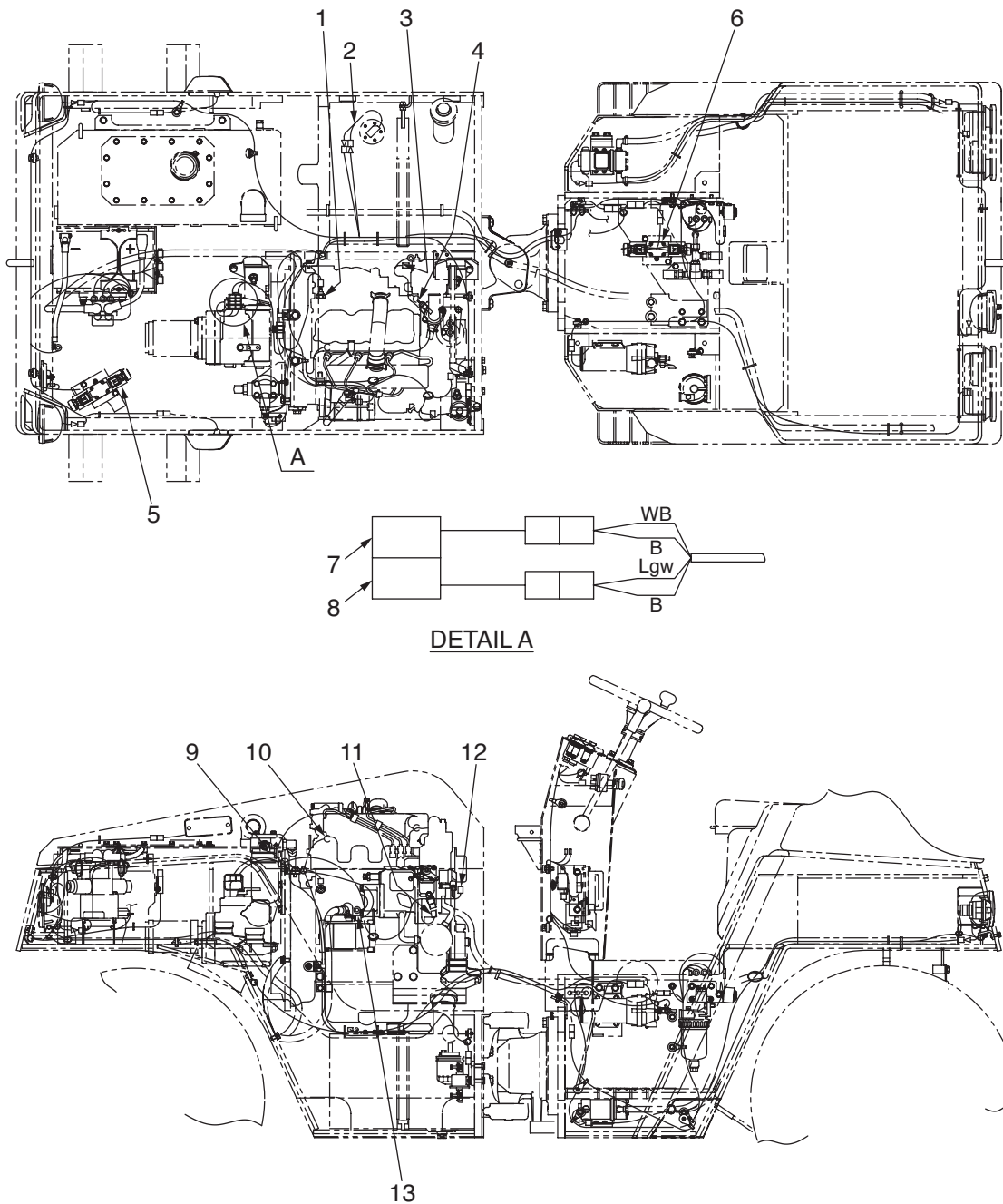

TW5022052

- | | | |
|--|---|--------------------------|
| 1. Engine oil pressure switch | 6. Amplitude selector solenoid valve (rear) | 10. Glow plug |
| 2. Fuel unit | 7. Brake release solenoid valve | 11. Tachometer sensor |
| 3. Alternator | 8. Speed selector solenoid valve | 12. Engine stop solenoid |
| 4. Thermo unit | 9. Hydraulic oil filter switch | 13. Starter |
| 5. Amplitude selector solenoid valve (front) | | |

★ Above figures illustrate location of electric key units of SW502.

6-4. Electric wiring diagram (TW352)

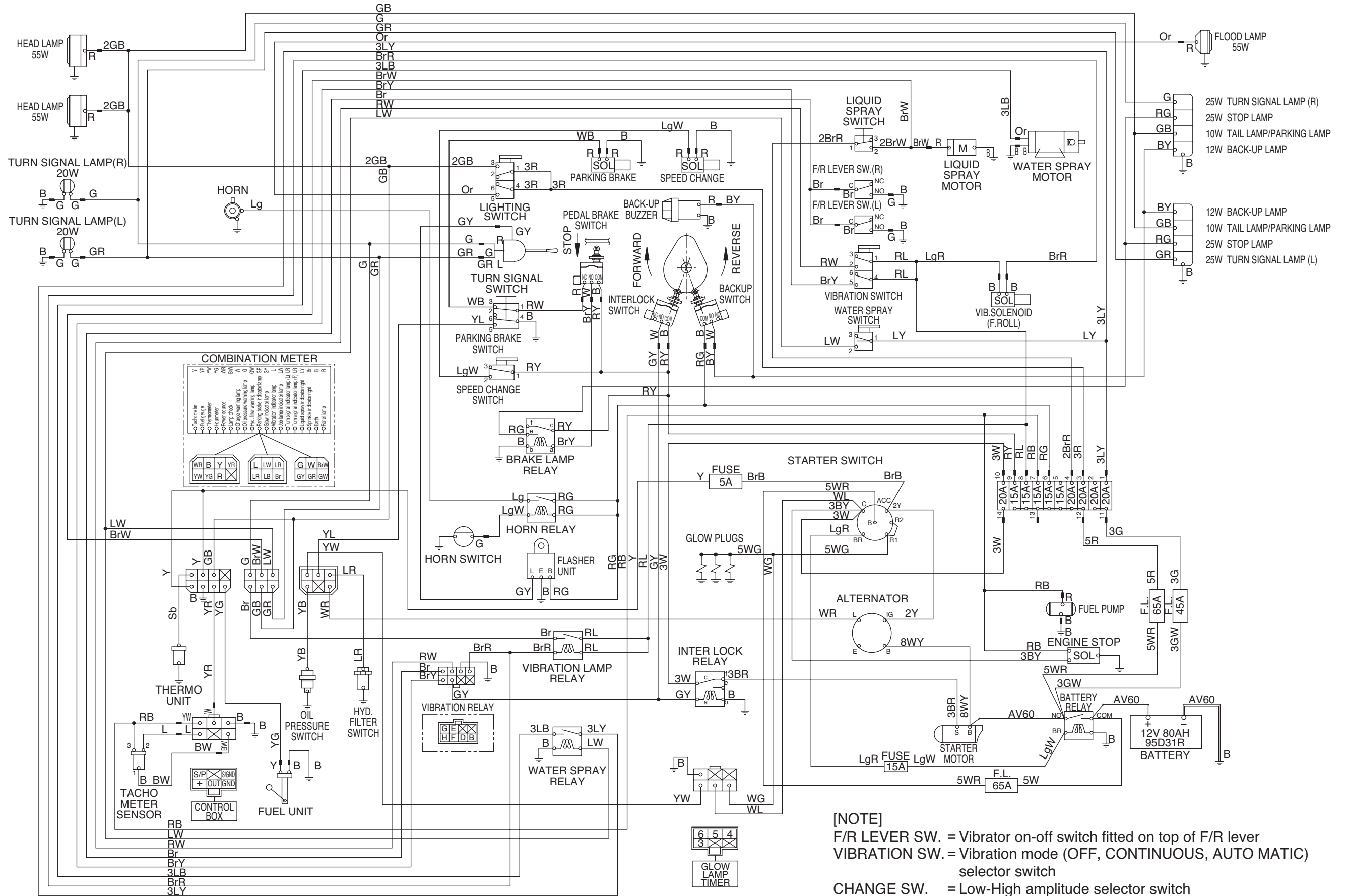

TW352

6-5. Electric wiring diagram (SW502)

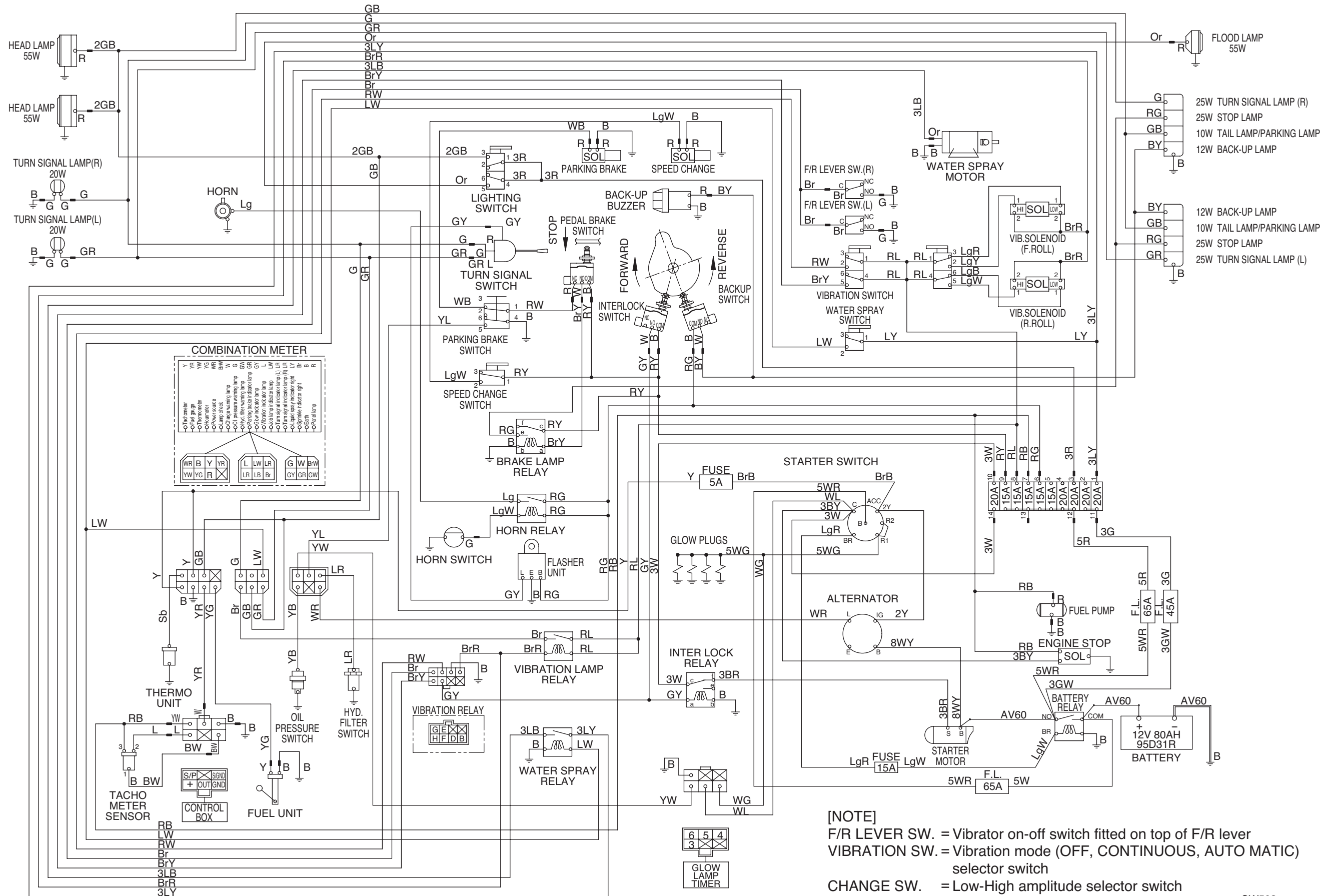

SW502

6-6. Electric wiring diagram (TW502)

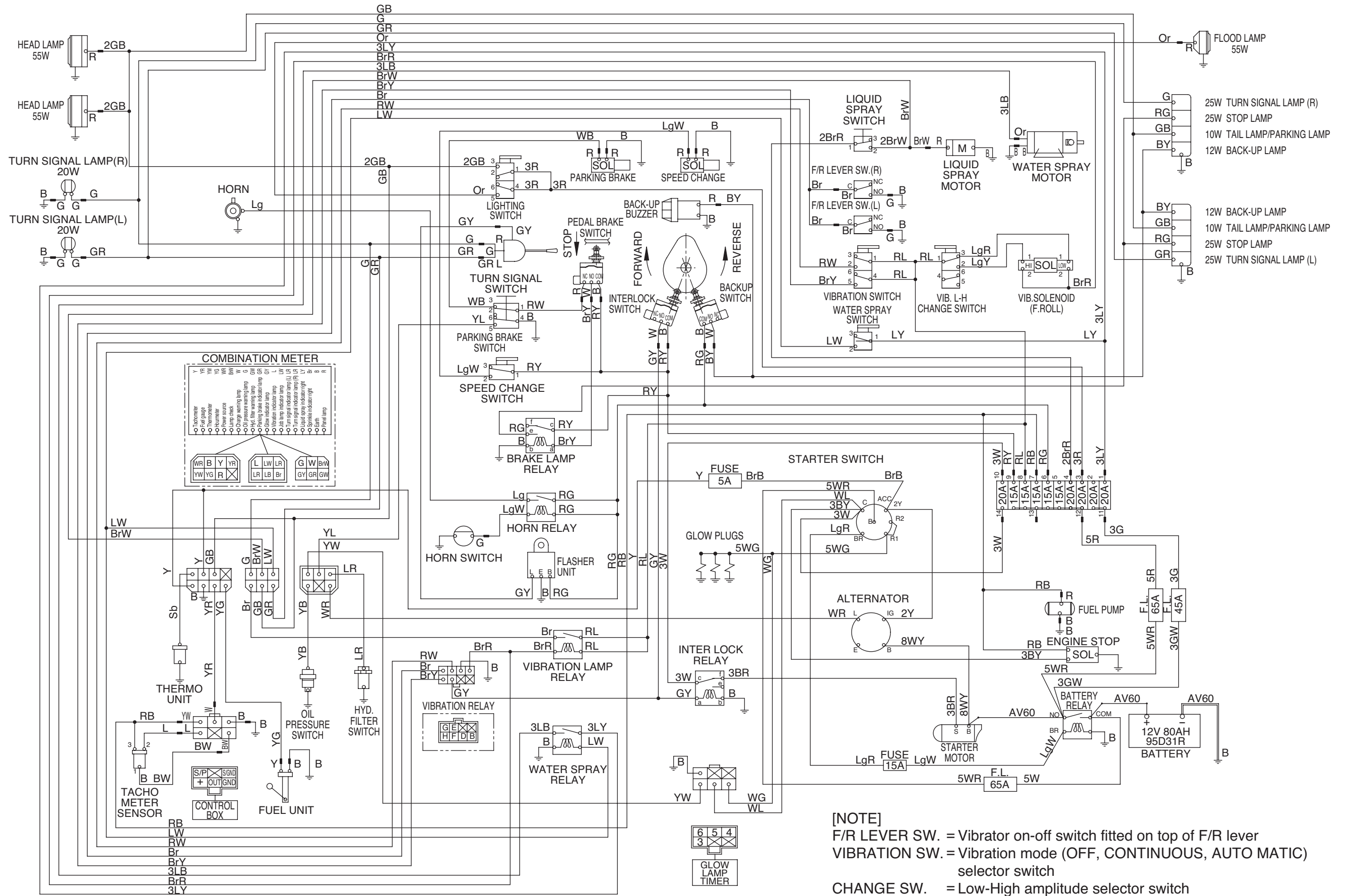

[NOTE]
 F/R LEVER SW. = Vibrator on-off switch fitted on top of F/R lever
 VIBRATION SW. = Vibration mode (OFF, CONTINUOUS, AUTO Matic) selector switch
 CHANGE SW. = Low-High amplitude selector switch

INSPECTION AND ADJUSTMENT

INSPECTION AND ADJUSTMENT

1. Standard Value Chart

1-1. SW352, TW352	3-002
1-2. SW502, TW502	3-003

2. Inspection and Adjustment

2-1. Measurement and adjustment of pressure in propulsion main circuit	3-101
2-2. Measurement and adjustment of propulsion charge circuit pressure	3-102
2-3. Measurement of propulsion motor speed selecting pressure	3-103
2-4. Measurement of brake release pressure	3-104
2-5. Measurement of vibrator circuit pressure	3-105
2-6. Measurement and adjustment of steering circuit pressure	3-107
2-7. Throttle linkage adjustment	3-108
2-8. Adjustment of F-R lever linkage stroke	3-109

Precautions for Use of Standard Value Chart

- 1) Values in the chart are based upon ones approved when the machine leaves the factory. They should be used for estimation of parts wear after extended operation and for guidance of repair.
- 2) Values in the chart are ones based on various test results etc. They should be used for a guide for fault finding practice in due consideration of the past repair frequency and operating record of the machine.
- 3) Values in the chart should not be used as standard for claim application.

Precautions for Checking, Adjustment and Fault Diagnosis

- * For checking, adjustment and fault diagnosis, park the machine on level ground and engage the safety pins.
- * When working with other workers, use hand signals positively and keep people not concerned away from the work area.
- * Cool off the engine coolant or hydraulic fluid when removing the radiator cap or the hydraulic tank filler cap. Hot fluids can burn you.
- * Do not put your hands close to parts in motion such as fan belts.

1. Standard Value Chart

1-1. SW352, TW352

Item			Measuring conditions	Unit	Standard value for new machine	Permissible range	
Engine	Speed	Low idle	<ul style="list-style-type: none"> Coolant temp. : Displayed on gauge Hydraulic oil working temperature : 50±5 °C 	min ⁻¹ (rpm)	950±25	←	
		High idle			2450±50	←	
		Rated speed			2300	←	
Travel speed	SW352	Forward	<ul style="list-style-type: none"> Engine: full throttle Coolant temp. : Displayed on gauge Hydraulic oil working temperature : 50±5 °C 	km/h	0~9.0±1.0	←	
					Hi	0~12.0±1.0	←
		Reverse			Lo	0~9.0±1.0	←
					Hi	0~12.0±1.0	←
	TW352	Forward			Lo	0~9.0±1.0	←
					Hi	0~12.0±1.0	←
		Reverse			Lo	0~9.0±1.0	←
					Hi	0~12.0±1.0	←
Hydraulic Oil pressure	Propulsion	Main circuit	<ul style="list-style-type: none"> Engine at full throttle Hydraulic oil working temperature : 50±5 °C See measurement procedure of pressure in each circuit. 	MPa (kgf/cm ²)	34.5±1 (350±10)	31.7 (323)	
		Charge circuit			1.9±0.2 (19.4±2)	1.8 (18.4)	
	Vibrator circuit	SW352			12.7±0.5 (130±5)	11.3 (115)	
		TW352			12.7±0.5 (130±5)	11.3 (115)	
	Steering circuit				13.5±0.5 (138±5)	12.4 (127)	
	Speed selector circuit				1.9±0.2 (19.4±2)	1.8 (18.4)	
	Brake release circuit				1.9±0.2 (19.4±2)	1.8 (18.4)	

1-2. SW502, TW502

Item			Measuring conditions	Unit	Standard value for new machine	Permissible range	
Engine	Speed	Low idle	<ul style="list-style-type: none"> Coolant temp. : Displayed on gauge Hydraulic oil working temperature : 50±5 °C 	min ⁻¹ (rpm)	950±25	←	
		High idle			2450±50	←	
		Rated speed			2300	←	
Travel speed	SW502	Forward	<ul style="list-style-type: none"> Engine: full throttle Coolant temp. : Displayed on gauge Hydraulic oil working temperature : 50±5 °C 	km/h	0~7.5±1.0	←	
					Hi	0~10.0±1.0	←
		Reverse			Lo	0~7.5±1.0	←
					Hi	0~10.0±1.0	←
	TW502	Forward			Lo	0~9.0±1.0	←
					Hi	0~12.0±1.0	←
		Reverse			Lo	0~9.0±1.0	←
					Hi	0~12.0±1.0	←
Hydraulic Oil pressure	Propulsion	Main circuit	<ul style="list-style-type: none"> Engine at full throttle Hydraulic oil working temperature : 50±5 °C See measurement procedure of pressure in each circuit. 	MPa (kgf/cm ²)	34.5±1 (350±10)	31.7 (323)	
		Charge circuit			1.8±0.2 (18.4±2)	1.6 (16.3)	
	Vibrator circuit	SW502			14.4±0.5 (147±5)	13.2 (135)	
		TW502			14.4±0.5 (147±5)	13.2 (135)	
	Steering circuit				13.5±0.5 (138±5)	12.4 (127)	
	Speed selector circuit				1.8±0.2 (18.4±2)	1.6 (16.3)	
	Brake release circuit				1.8±0.2 (18.4±2)	1.6 (16.3)	

2. Inspection and Adjustment

2-1. Measurement and adjustment of pressure in propulsion main circuit

1. Measurement

· Hydraulic oil temperature: 50 ± 5 °C

- ⚠ Park the machine on level ground. Stop the engine. Block the wheels.
- ⚠ Make certain that the parking brake functions correctly.

1) Remove plugs (1) and (2) from the gauge ports of propulsion pump. Fit a pressure gauge with adapter ①.

- Gauge port: 9/16-18UNF-2B
- Forward travel gauge port: (1)
- Reverse travel gauge port: (2)
- Pressure gauge: 0-49.0 MPa
(0-500 kgf/cm²)

2) Apply the parking brake by pressing the parking brake switch button. Set the speed selector switch to the HIGH speed range (↔).

3) Start the engine and move the F-R lever slowly in either direction forward or backward as required until the engine reaches its rated speed. Then take the pressure gauge reading at the rated speed.

★ When the measurement is complete, return the F-R lever to the neutral position immediately.

2. Adjustment

* If the measured value falls outside the permissible range, disassemble and wash clean or renew the pressure relief valve assembly.

★ The valve is of a non-adjustable type. Do not try to adjust it.

- ⚠ Carefully perform disassembly and reassembly to prevent ingress of foreign matter.

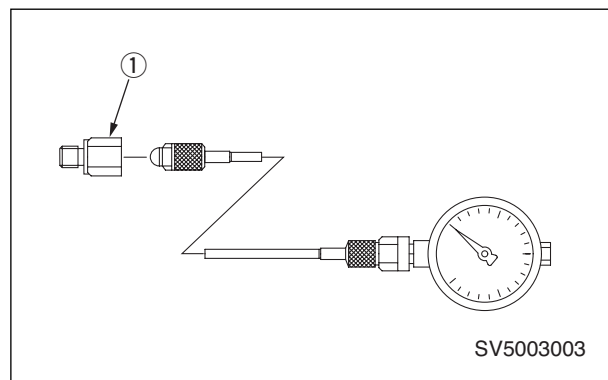
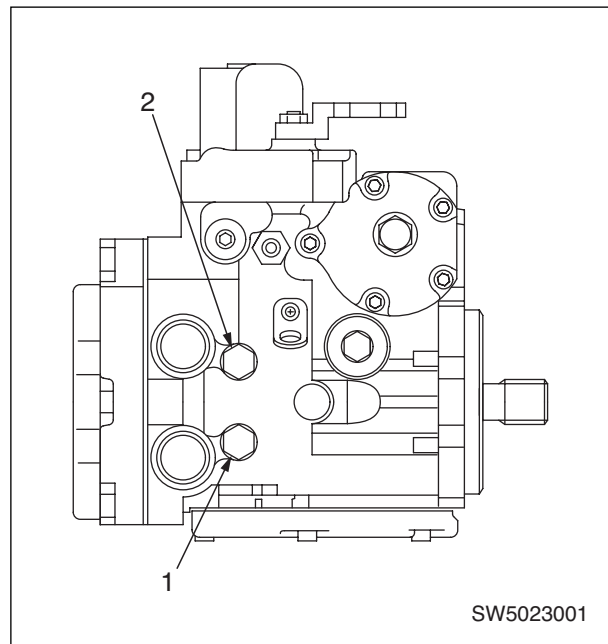

2-2. Measurement and adjustment of propulsion charge circuit pressure

1. Measurement

- Hydraulic oil temperature: 50 ± 5 °C

▲ Position the machine on level ground.

Stop the engine and chock the wheels.

★ Because oil is supplied from the steering/charge pump, make sure, prior to measurement, that the steering system works correctly.

★ Ensure that the pump swashplate is in the exact neutral position with the F-R lever placed in the neutral position.

- Remove plugs from servo pressure gauge points (1) and (2) of the propulsion pump. Attach a pressure gauge with adapter (2).
 - Servo pressure gauge port: 9/16-18UNF-2B
 - Pressure gauge: 0-4.9 MPa (0-50 kgf/cm²)
- Start the engine and set the throttle lever to the high idle position.
- Make sure that the F-R lever is in the neutral position. Take the gauge reading.

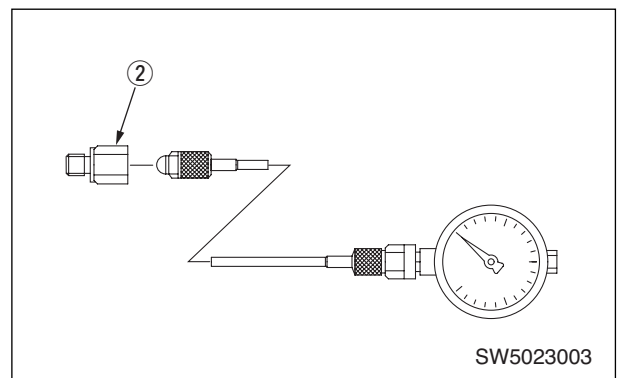
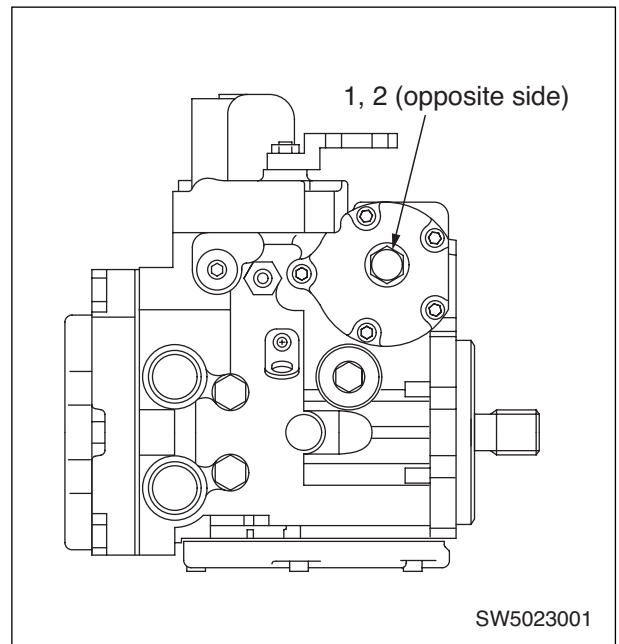

2. Adjustment

If the measured value falls outside the permissible range, disassemble and wash clean or renew the pressure relief valve assembly.

★ The valve is of a non-serviceable item. Do not attempt to adjust it.

▲ Carefully perform disassembly and reassembly to prevent ingress of dirt or other contaminations.

2-3. Measurement of propulsion motor speed selecting pressure

1. Measurement

- Hydraulic oil temperature: 50 ± 5 °C
 - ▲ **Position the machine on level surface.**
Stop the engine and place chock blocks in front and rear of wheels.
 - ★ **Prior to measurement, check that the steering system works correctly, since oil is fed from the steering/charge pump.**
- 1) Disconnect hose (1) in the speed selecting line from the propulsion motor. Attach a pressure gauge with adapter (3).
 - Pressure gauge: 0-4.9 MPa (0-50 kgf/cm²)
- ★ **These procedures should not apply to the rear motors.**
- 2) Start the engine and set the throttle lever to the high idle position.
 - 3) Set the speed selector switch to the High speed range and take the gauge reading.

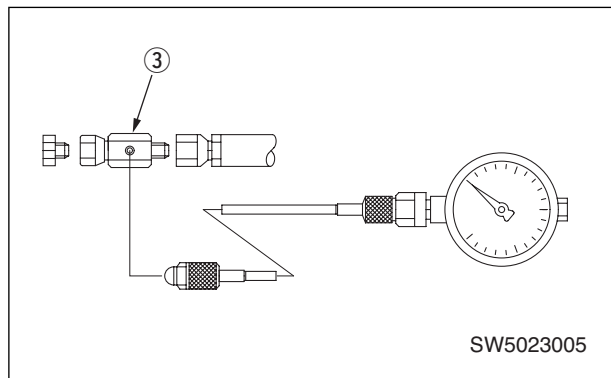
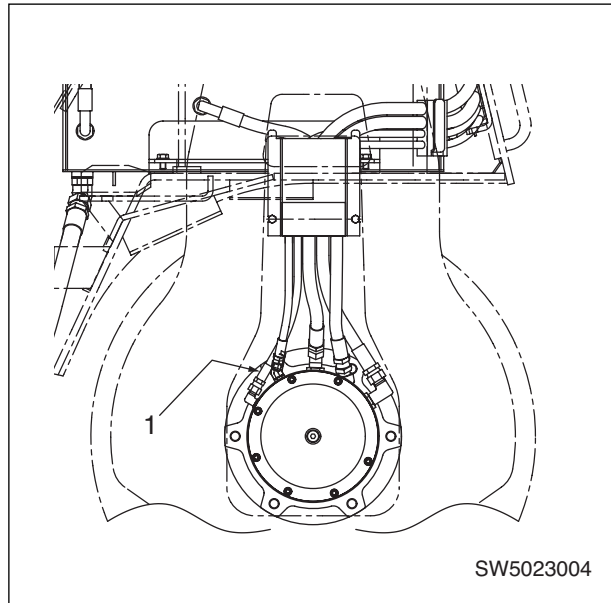

2-4. Measurement of brake release pressure

1. Measurement

· Hydraulic oil temperature: 50 ± 5 °C

▲ Park the machine on level surface. Stop the engine and block the wheels.

★ Make certain that, prior to measurement, the steering system functions correctly, as oil is supplied from the steering circuit.

1) Disconnect hoses (1) to (4) in the brake release line from the relevant propulsion motors. Attach a pressure gauge with adapter ④.

· Pressure gauge: 0-4.9 MPa (0-50 kgf/cm²)

2) Making sure that the F-R lever is in the neutral position, start the engine and put the throttle lever in the high idle position.

3) Take the gauge reading with the parking brake switch set to the RELEASE position.

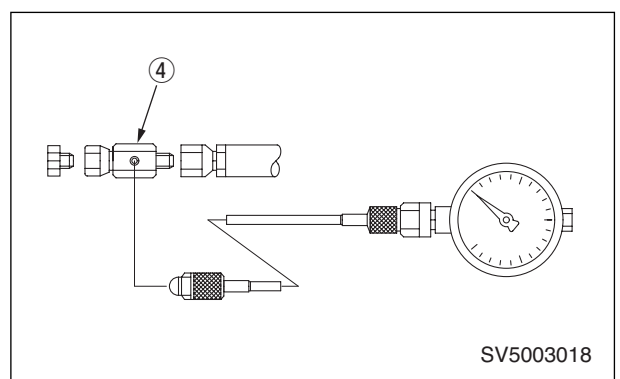
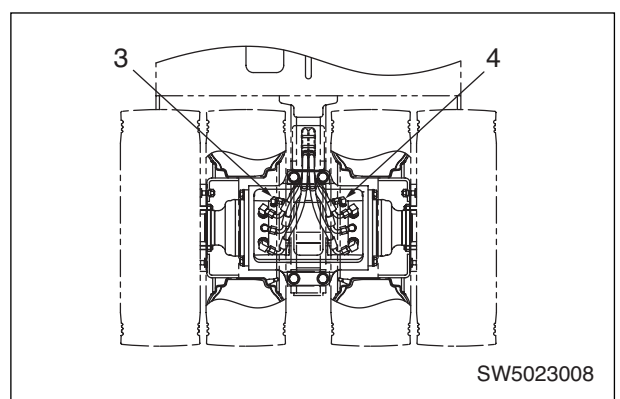
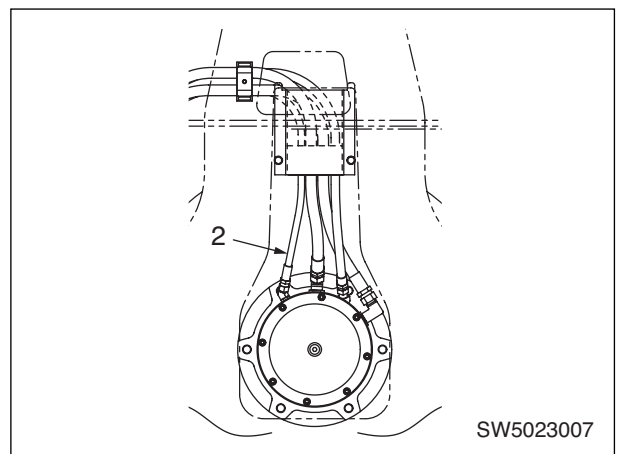
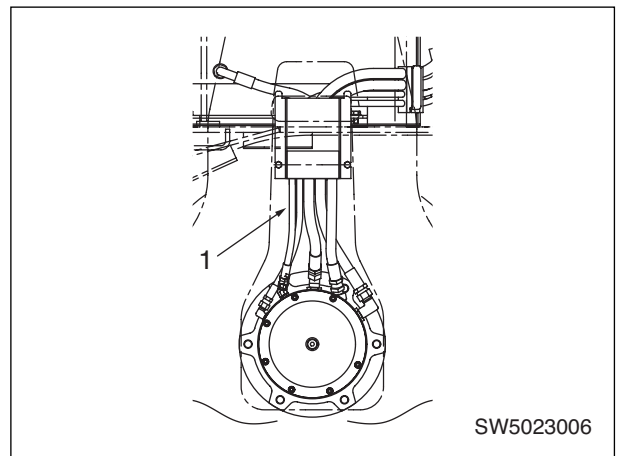

2-5. Measurement of vibrator circuit pressure

1. Measurement

- Hydraulic oil temperature: 50 ± 5 °C

▲ Position the machine on level surface.

Stop the engine and block the wheels.

SW352, TW352

- 1) Disconnect hose (1) at the high pressure inlet port of the front vibrator motor. Fit adapter (5).

★ TW352 has vibrating unit in the front drum alone.

- 2) Install a 0-24.5 MPa (0-250 kgf/cm²) pressure gauge to adapter (5).
- 3) Start the engine. Move the throttle lever to the high idle position.
- 4) Operate the vibrator mode selector switch from OFF to MANUAL mode (☞). Then switch on the vibrator on-off switch located on top of the F-R lever. Take the gauge reading.

★ Use the similar procedures for the rear vibrator motor.

2. Adjustment

If measured values fall outside the specified range, adjust as follows:

- 1) Slacken locknut (3) of the relief valve. Make adjustment by turning adjusting screw (4).
 - Clockwise rotation raises the pressure.
 - Counterclockwise rotation lowers the pressure.

★ Make the adjustment with the solenoid energized.

- 2) When adjustment is complete, check to make sure that the pressure has been correctly set.
- 3) If the valve is beyond adjustment, disassemble and clean or renew the relief valve assembly.

▲ Carefully perform disassembly and reassembly taking necessary means to avoid ingress of dust or other contaminations.

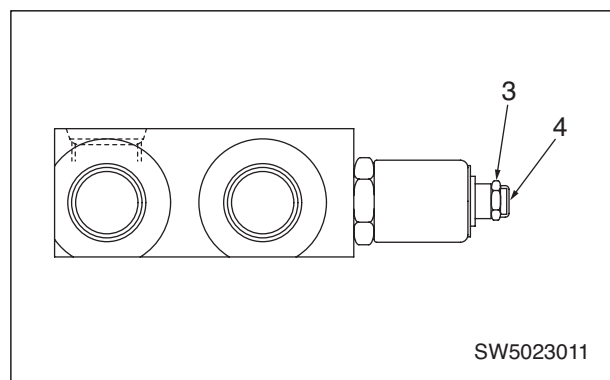
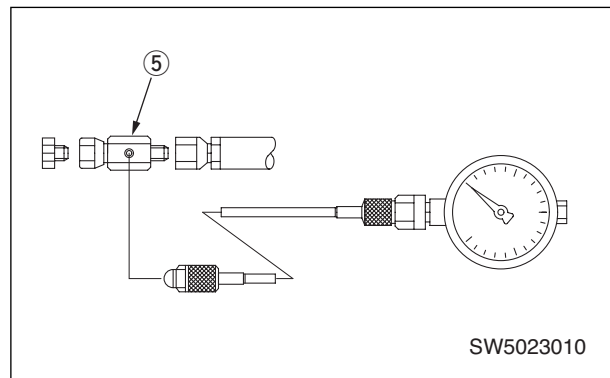
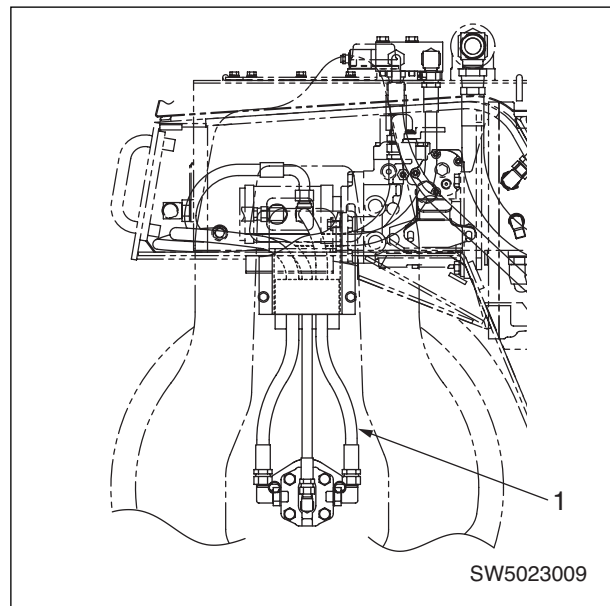

SW502, TW502

- 1) Disconnect hose (1) from the front propulsion motor at the high pressure inlet port for low amplitude or hose (2) at the high pressure inlet port for high amplitude. Fit adapter ⑤.

★ **TW502 has the front vibrator alone.**

- 2) Install a 0-24.5 MPa (0-250 kgf/cm²) pressure gauge to adapter ⑥.
- 3) Start the engine. Set the throttle lever to the high idle position.
- 4) Select LOW amplitude or HIGH amplitude by actuating the amplitude selector switch. Operate the vibrator mode selector switch from OFF to MANUAL mode (☞). Then switch on the vibrator on-off switch located on top of F-R lever, and take the pressure gauge reading.

★ **Use similar procedure for the measurement of the rear vibrating unit.**

2. Adjustment

- ★ If the measured value falls outside the permissible range, renew the relief valve assembly.
- ★ **The valve is of a non-serviceable type. Do not attempt to adjust it.**
- ⚠ **Carefully perform disassembly and reassembly taking necessary means to avoid entry of foreign matter.**

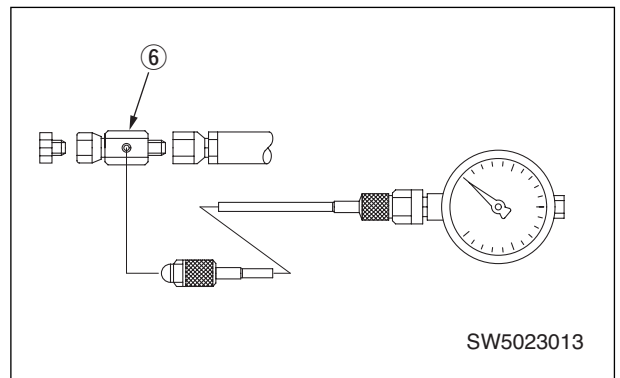
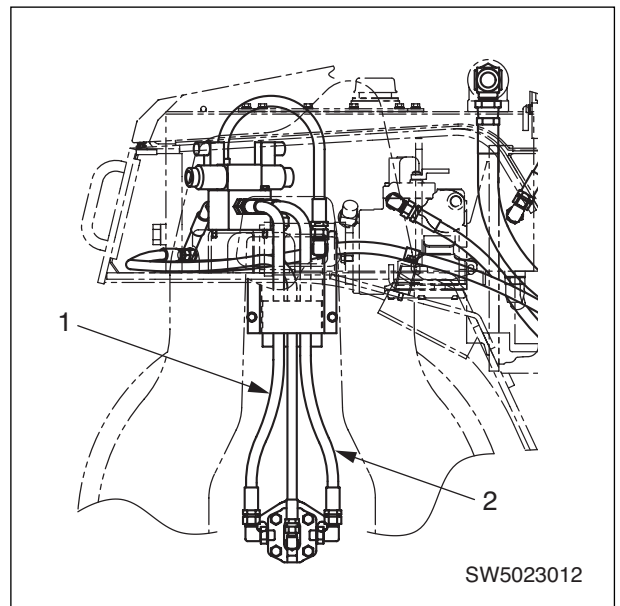

2-6. Measurement and adjustment of steering circuit pressure

1. Measurement

- Hydraulic oil temperature: 50 ± 5 °C

⚠ Position the machine on level ground.

Stop the engine. Chock the wheels.

★ Because the return line of the steering circuit makes the pressure source of the propulsion charge circuit, ensure before measurement, that the steering system operates correctly.

- 1) Disconnect hose (1) at the outlet port of the steering pump, and fit adapter (7). Then reconnect the hose.
- 2) Install a 0-24.5 MPa (0-250 kgf/cm²) pressure gauge to adapter (7).
- 3) Start the engine. Ensuring that the F-R lever is in the neutral position, operate the throttle lever to select the high idle position.
- 4) Rotate the steering wheel clockwise or counterclockwise to full lock in order to allow the pressure relief valve to release the pressure. Take the gauge reading.

* When rotating the steering wheel, do not allow anyone to enter the pinch area of the articulated frame.

2. Adjustment

If the measured value is not within the permissible range, disassemble and clean or renew the relief valve assembly built in Orbitrol.

★ The valve is not adjustable. Do not attempt to adjust it.

⚠ Carefully perform disassembly and reassembly taking necessary means to avoid entry of foreign matter.

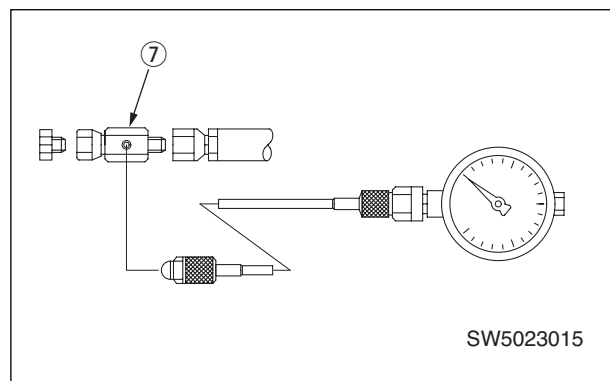
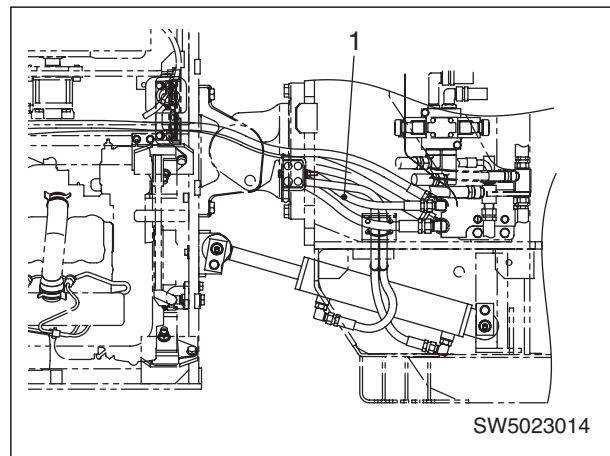

2-7. Throttle linkage adjustment

When the throttle linkage has been renewed or if the high idle or low idle rpm is not to specification, adjust as follows:

1. Adjustment

• **Coolant temperature: As indicated on gauge**

- 1) Set throttle lever (1) to the LOW idle position.
- 2) Connect control cable (2) to fuel injection pump governor lever (3).
- 3) Start the engine. Slacken lock nut (4) and adjust stop bolt (5) until correct low idle revolution is obtained.
 - Low idle: 950±50 rpm for SW352, TW352
 - 950±50 rpm for SW502, TW502
- 4) With throttle lever (1) moved to the full throttle position, loosen locknut (7) and adjust stop bolt (8) so that governor lever (3) makes contact with stopper (6) on the full throttle side.
- 5) Start the engine. Check that the high idle rpm is to specification.
 - High idle: 2450±50 rpm for SW352, TW352
 - 2450±50 rpm for SW502, TW502

★ If high idle is lower than specified with governor lever (3) in contact with the stopper on the full throttle side, adjust the fuel injection nozzles or repair or renew the fuel injection pump.

★ On emission controlled engines, neither Low idle nor high idle is not allowed to adjust.

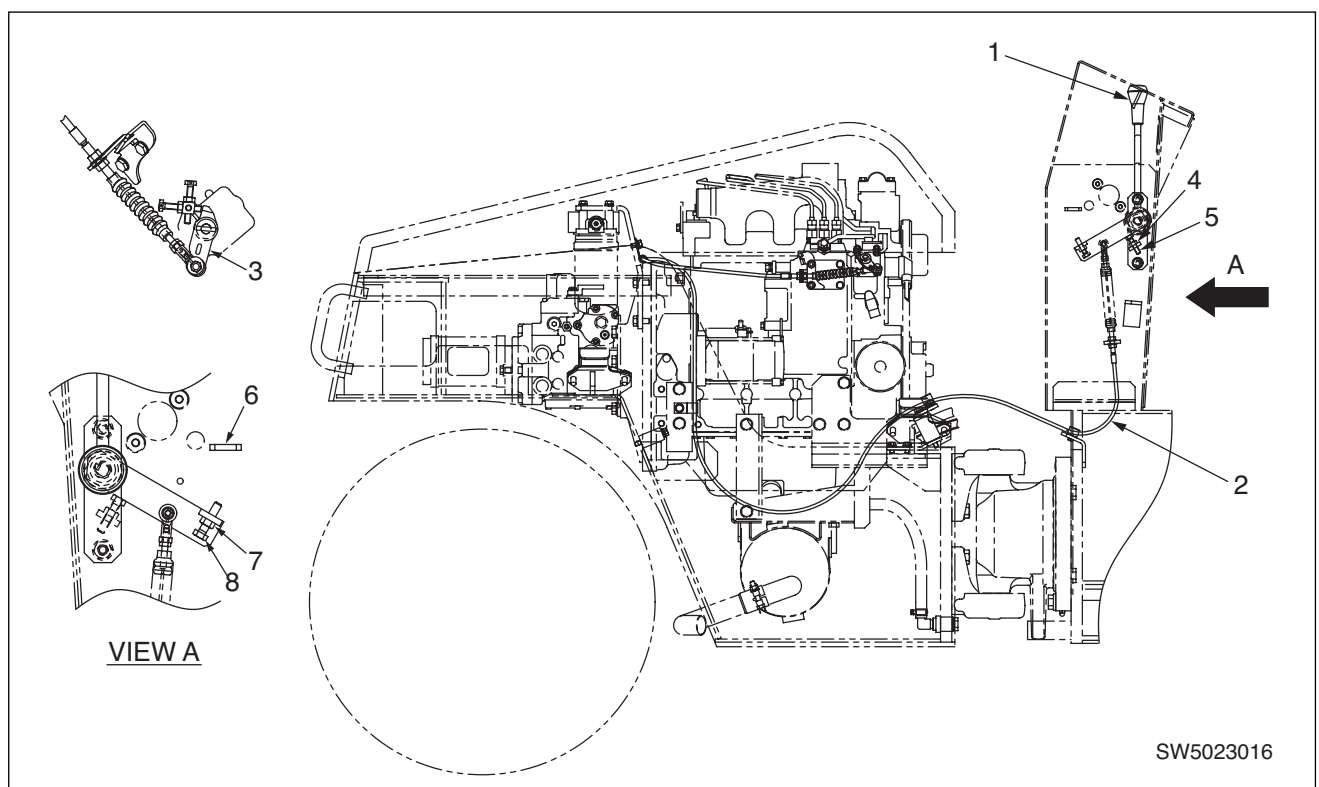

2-8. Adjustment of F-R lever linkage stroke

▲ Park the machine on level ground. Stop the engine. Chock the wheels.

★ When the propulsion pump or F-R lever linkage has been renewed or if the F-R lever fails to move smoothly, adjust the F-R lever stroke as instructed below:

1. Adjustment

· Hydraulic oil temperature: 50 ± 5 °C

★ Because the neutral position of F-R levers (1) and (2) in the driver's station are positively set by a notch ball, check for the stroke of the lever on the pump side.

1) Connect control cable (3) to arm (4).

★ Check that the F-R lever is moved smoothly.

2) Connect control cable (5) to arm (4).

★ Arm (4) fixed to pump control lever (5) keeps the pump control lever in the exact neutral position. Ensure that the stroke of control lever (5) is as specified.

· Maximum stroke of control lever (for forward and reverse each):

a=21 mm (0.83 in)

b=21 mm (0.83 in)

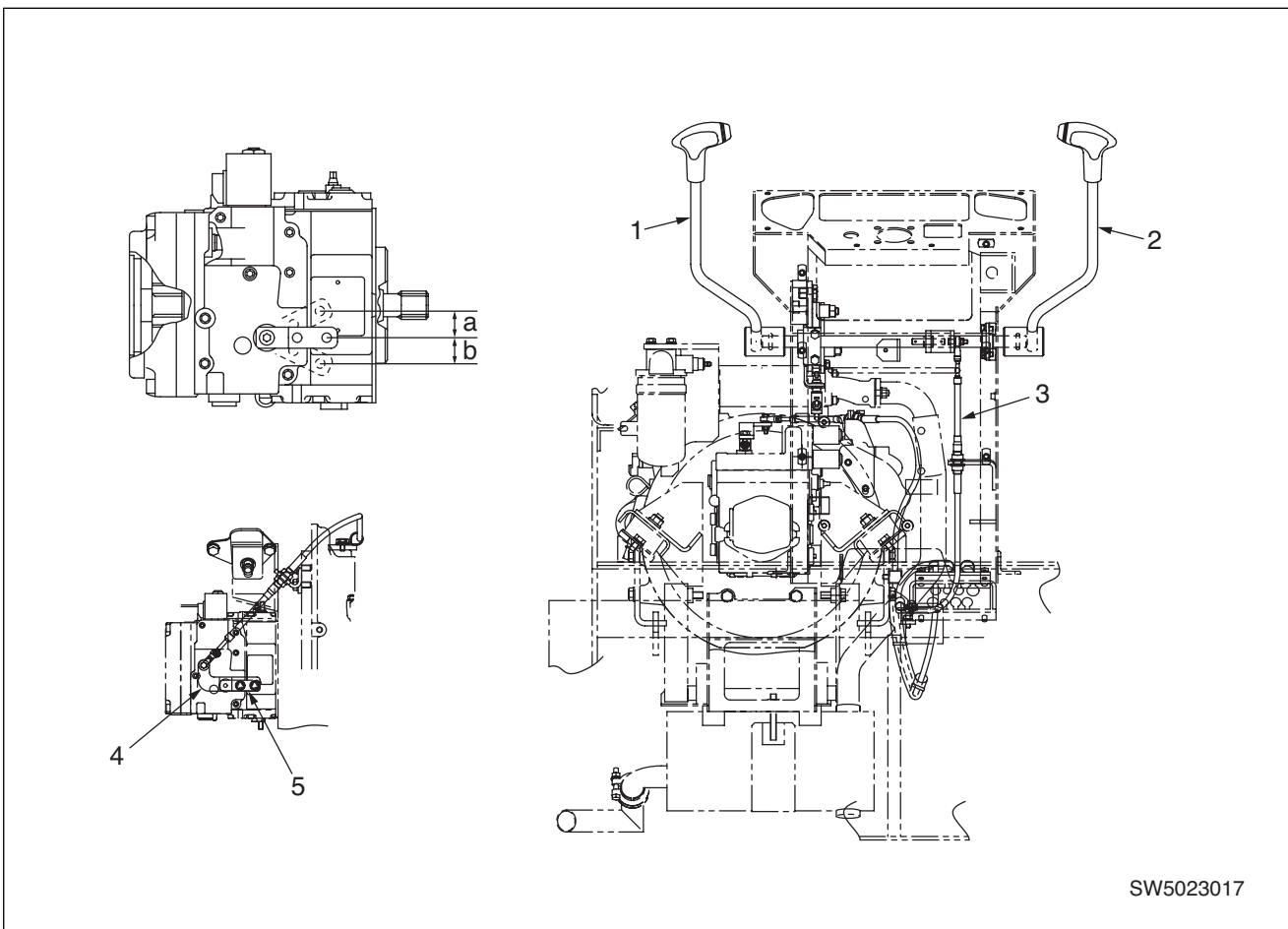

SW5023017

FAULT DIAGNOSIS

FAULT DIAGNOSIS

1. Precautions for Fault Diagnosis	4-002
2. How to Make a Fault Diagnosis	4-003
3. How to Use Fault Diagnosis Flow Chart	4-004
4. Precautions for Fault Diagnosis of Electric System	4-006
5. Fault Diagnosis of Electric System (Mode E)	4-201
6. Fault Diagnosis of Hydraulic and Mechanical Systems (Mode H)	4-401

1. Precautions for Fault Diagnosis

- ⚠️ **Park the machine on level ground. Make sure that the safety pins are engaged, wheels chocked and parking brake applied.**
- ⚠️ **When working with other workmates, use hand signals authorized, and keep people not concerned away from the work area.**
- ⚠️ **If the radiator cap is carelessly removed from a hot engine, hot coolant will gush out to cause a burn. Remove the cap only when the engine has been cooled off.**
- ⚠️ **Exercise care not to touch hot parts or not to get caught in rotating parts.**
- ⚠️ **When disconnecting electric wires, disconnect the battery negative (–) cable.**
- ⚠️ **When taking off plugs or caps from units which are under pressure such as hydraulic, water and air pressures, remove residual pressure first.**

- Fault diagnosis is to determine the root cause of trouble. Repair faulty parts as quickly as practicable, and prevent recurrence of the trouble.
- Important when making a diagnosis is of course to well understand the structure and function of the machines at fault. For effective fault diagnosis, however, it is of prime importance to have a clear picture of the trouble concerned by contacting the operator.

1. When a trouble has occurred, do not attempt to disassemble suspected parts blindly.

Disassembling in a hurry without careful considerations will invite disadvantageous situations as described below:

- Parts which need not be disassembled may be disassembled.
- Tracing the cause of trouble will become more difficult.

These will cause increased service costs because of wasteful service hours, spare parts or expendables like oil or grease. To make matters worse, such a careless practice will invite operator's (customer's) distrust. For these reasons, a full investigation and a prudent diagnosis in accordance with fault diagnosis procedures recommended are essential for efficient fault finding practices.

2. Questions to be addressed to the operator (customer).

- 1) Are there any trouble other than the one in question?
- 2) Had there been any unusual conditions with the machine before the trouble has occurred?
- 3) Has the trouble occurred suddenly without showing any signs of unusual conditions in advance?
- 4) In what occasion has the trouble occurred?
- 5) Had the machine been repaired before the trouble has occurred? If so, when had it been repaired?

- 6) Had similar trouble occurred before the trouble has developed?

3. Before-diagnosis inspections

- 1) Perform daily inspections.
- 2) Perform other inspections necessary for diagnosis.

4. Confirmation of trouble

Know the degree of the trouble. Determine whether the trouble is attributable to a structural defect etc or trouble caused by incorrect handling.

*** When making the trouble recur in an attempt to trace the source of the trouble by putting the machine in motion, use care not to cause more damages to the machine.**

5. Fault diagnosis

From the results of items 2 to 4 above, narrow down the cause of the trouble, and pinpoint its source by utilizing the diagnosis flow chart.

★ **The basic points of the diagnosis are:**

- 1) Start from the simple portion.
- 2) Start from the portion having a high probability.
- 3) Investigate related matters.

6. Fundamental remedy for a trouble

Even if a trouble has been rectified, it will develop again if its cause is not determined. It is of prime importance to grasp the very cause of the trouble.

2. How to Make a Fault Diagnosis

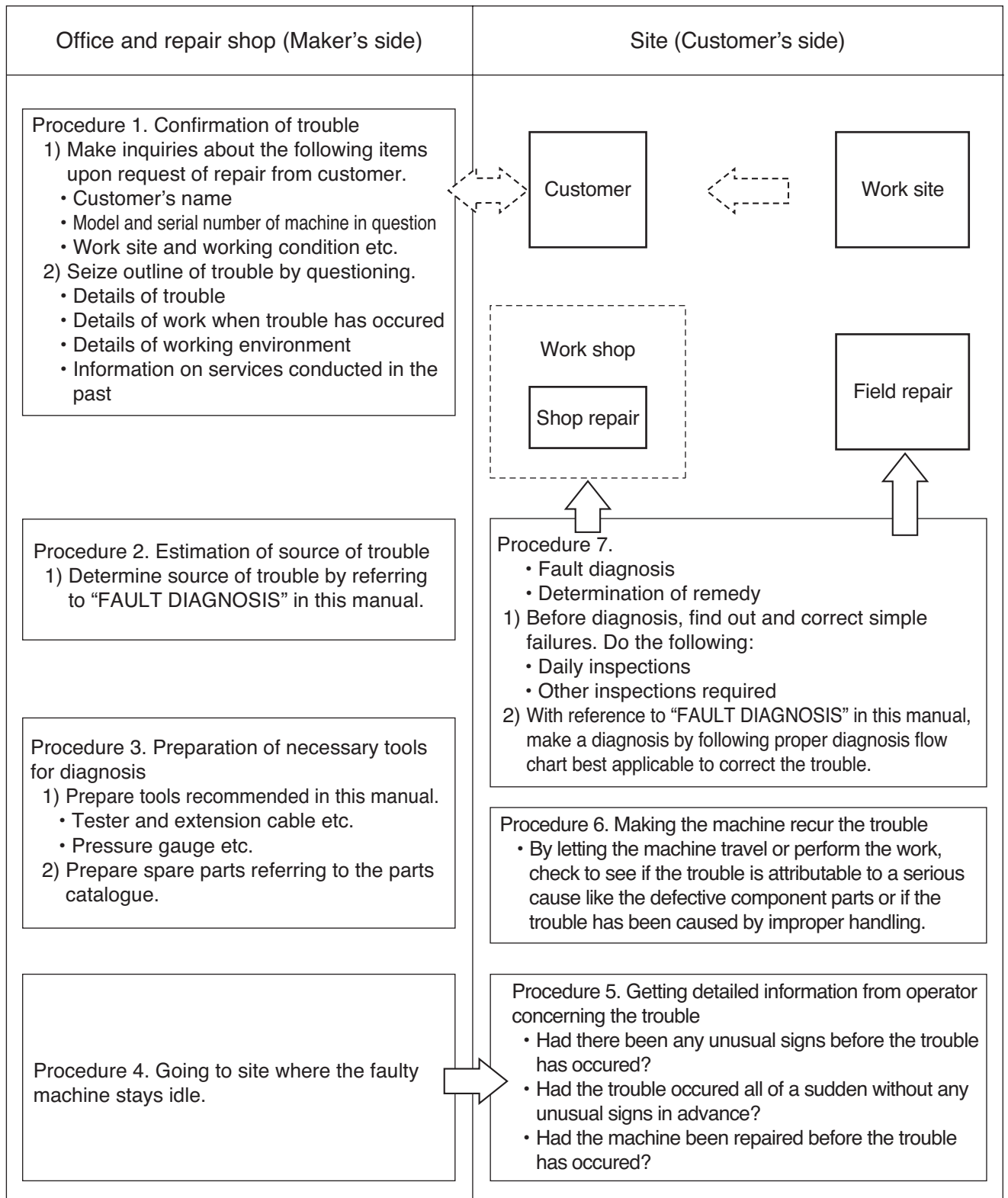

3. How to Use Fault Diagnosis Flow Chart

1. Fault diagnosis code numbers

- 1) Electric system: E-01 to E-09
- 2) Hydraulic and mechanical systems: H-01 to H-09

2. How to use the fault diagnosis flow chart

Example

- ① E-10 Headlamps do not work
- ② ★ It is assumed that other electric circuits are normal.
★ Take the voltage measurement with the starter switch ON.
- ③ a) Tail lamps and work lamps are also faulty.
- ④

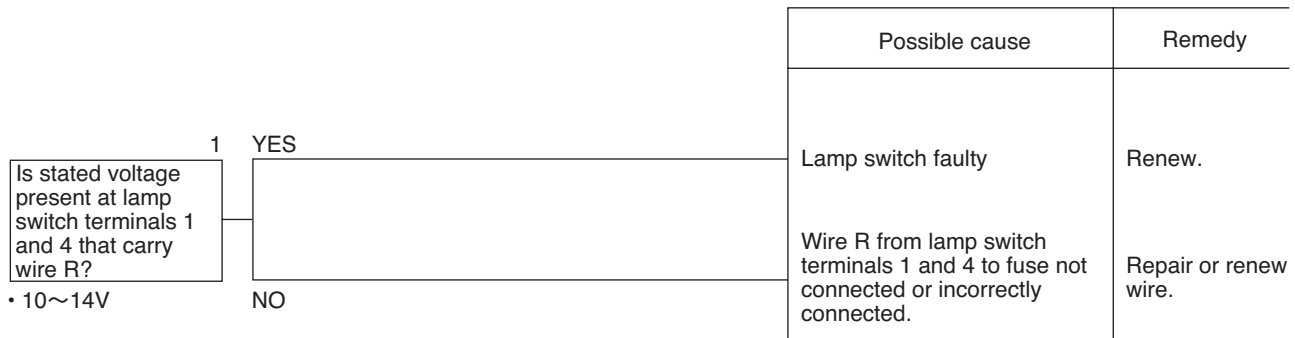

① Fault diagnosis code number and fault symptom

On top of the flow chart are code number and fault symptom.

② General precautions

Under the code number and fault symptom are precautions with mark ★. Take necessary measures as instructed by these precautions when making the inspection described in each checking instruction box (□).

③ Sub classification

To make diagnosis easier or simplify the flow chart, fault symptom is subclassified. Ex. a) Starter does not run.

④ How to make diagnosis

- Each box (□) contains a diagnosis procedure. Depending upon the result inspection or measurement, proceed to YES or NO line.
- Normally, if the result is YES then proceed to the upper line. If NO then go to the lower line.
- ★ The number above each box (□) is a reference number. It does not mean a sequence in which diagnosis procedure should proceed.

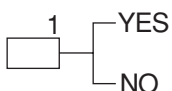

- As a result of checking, if YES line or NO line directly goes to the description in the CAUSE column, take necessary action as indicated in the REMEDY column.
- Under each box (□) are standard value and condition necessary for diagnosis procedure. If the result gives an affirmative answer to the question addressed in the box or agrees with the value indicated under the box, then go to YES line. Otherwise, go to NO line.
- The standard values have been taken from the standard value list.
- For the location of component parts such as relays mentioned in the flow chart, see the drawing which shows the location of key units. The line colors mentioned in the flow charts are indicated in the electric wiring diagram shown under the flow chart. In the actual machine, each wire is also identified by color.

4. Precautions for Fault Diagnosis of Electric System

1. When disconnecting or connecting connectors or harnesses, cut the power supply.
2. Before making a diagnosis, check the connectors or harnesses for poor connection.
★ Check connectors by repeating connection and disconnection practices several times.
3. Before proceeding to the subsequent step, reconnect removed connectors or harnesses in place.
★ If the power source is connected with the connectors disconnected, unusual indication will be given.
4. When making diagnosis of circuit troubles (while performing measurement of voltage, resistance and current or continuity test, etc.), check to see if the tester readings vary by shaking connectors or harnesses.
★ If readings vary, a possible cause is a poor connection of the circuit.
5. For voltage measurement, turn the starter switch ON. For resistance checking, set the switch in the Off position.
★ If necessary to take a measurement of resistance by energizing relays or other units with the starter switch ON, the instruction to do so is given under the checking instruction box (□) in the flow chart.

5. Fault Diagnosis of Electric System (Mode E)

E-01 Engine does not start4-202
 E-02 Engine does not stop4-205
 E-03 Glow Plugs do not become red-hot (difficult starting)4-206
 E-04 No charging (charge indicator lamp on monitor display comes on)4-207
 E-05 Fuel pump does not operate4-207
 E-06 Vibrator does not work4-208
 E-07 Sprinkler does not operate4-214
 E-08 Low-High speed range selection is not available4-215
 E-09 Parking brake is not released4-216

Wire color code

B	Black	BrY	Brown/ Yellow stripe	L	Blue	LgY	Light green/ Yellow stripe	W	White	YL	Yellow/ Blue stripe
BR	Black/ Red stripe	G	Green	LR	Blue/ Red stripe	R	Red	WB	White/ Black stripe	YR	Yellow/ Red stripe
BW	Black/ White stripe	GB	Green/ Black stripe	LW	Blue/ White stripe	RB	Red/ Black stripe	WL	White/ Blue stripe	YW	Yellow/ White stripe
BY	Black/ Yellow stripe	GL	Green/ Blue stripe	LY	Blue/ Yellow stripe	RG	Red/ Green stripe	WR	White/ Red stripe	Gy	Gray
Br	Brown	GR	Green/ Red stripe	Lg	Light green	RL	Red/ Blue stripe	WY	White/ Yellow stripe	O	Orange
BrB	Brown/ Black stripe	GW	Green/ White stripe	LgB	Light green/ Black stripe	RW	Red/ White stripe	Y	Yellow	Sb	Sky blue
BrR	Brown/ Red stripe	GY	Green/ Yellow stripe	LgR	Light green/ Red stripe	RY	Red/ Yellow stripe	YB	Yellow/ Black stripe	P	Pink
BrW	Brown/ White stripe			LgW	Light green/ White stripe			YG	Yellow/ Green stripe		

E-01 Engine does not start

- ★ Set the F-R lever to the neutral position.
- ★ Check for burnt fuse first.
- ★ For voltage measurement, turn the starter switch ON.

a) Starter motor does not operate. (1/2)

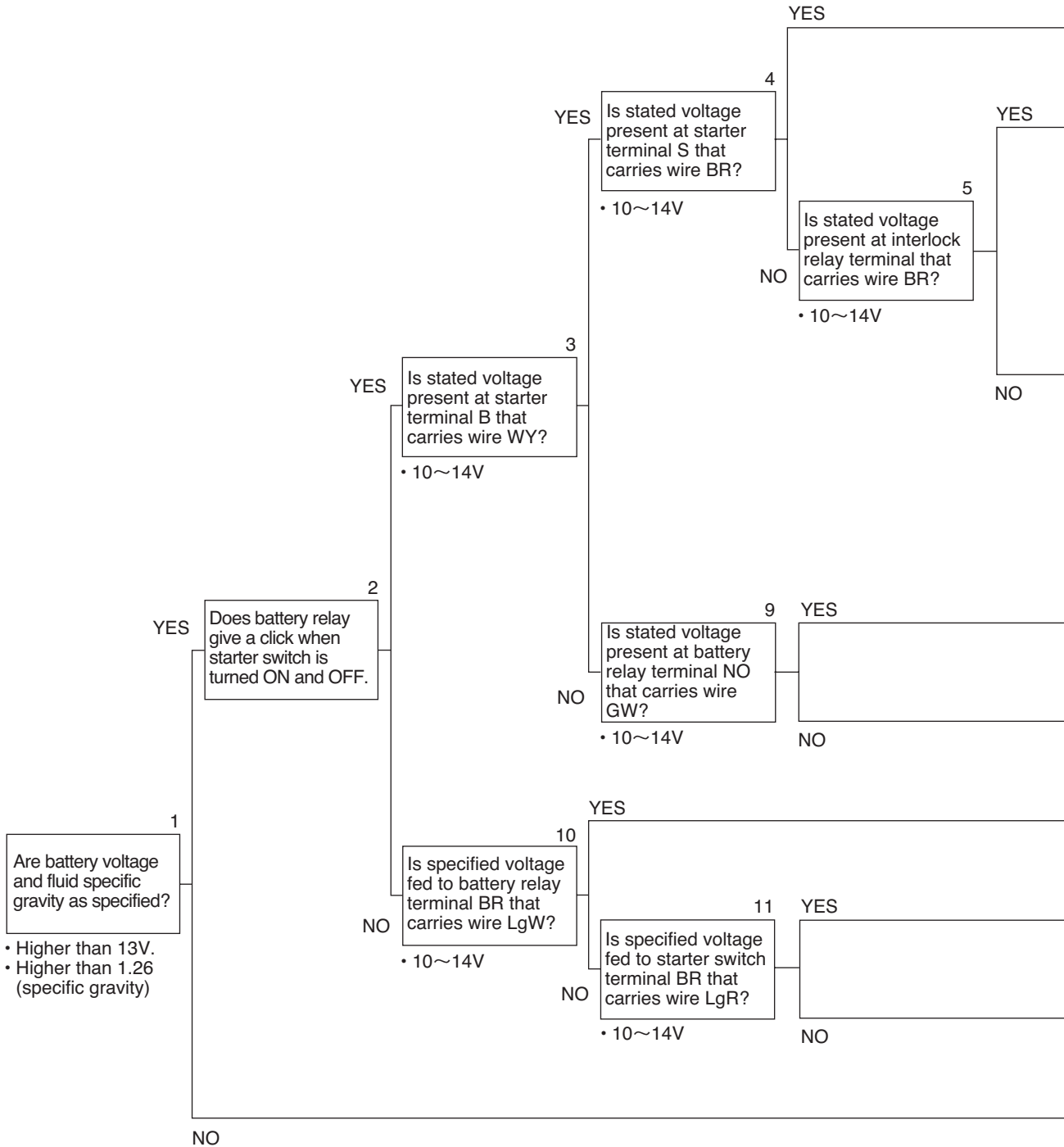

	Possible cause	Remedy
	Starter faulty.	Renew.
	Wire from interlock relay terminal to starter terminal S not connected or incorrectly connected.	Repair or renew wire.
<p>6</p> <p>Is stated voltage present at interlock relay terminal that carries wire W? • 10~14V</p>		
<p>YES</p> <p>7</p> <p>Is stated voltage present at interlock relay coil that carries wire GY? • 10~14V • Turn starter switch to START.</p>	<p>YES</p>	Renew.
<p>NO</p> <p>8</p> <p>Is stated voltage present at starter switch terminal C that carries wire W? • 10~14V • Turn starter switch to START.</p>	<p>NO</p>	Renew.
	Interlock relay faulty.	Renew.
	F-R lever interlock switch faulty.	Renew.
	Wire W from starter switch terminal C to interlock relay terminal not connected or incorrectly connected. (including fuse)	Repair or renew wire.
	Starter switch faulty. (between B and C)	Renew.
	Cable from battery relay terminal NO to starter not connected or incorrectly connected.	Repair or renew wire.
	Battery relay contact faulty.	Renew.
	Battery relay coil faulty.	Renew.
	Wire LgR or LgW from starter switch terminal BR to battery relay terminal BR not connected or incorrectly connected.	Repair or renew wire.
	To A on next page	
	Battery capacity lowered.	Charge or renew battery.

Fault Diagnosis of Electric System (Mode E)

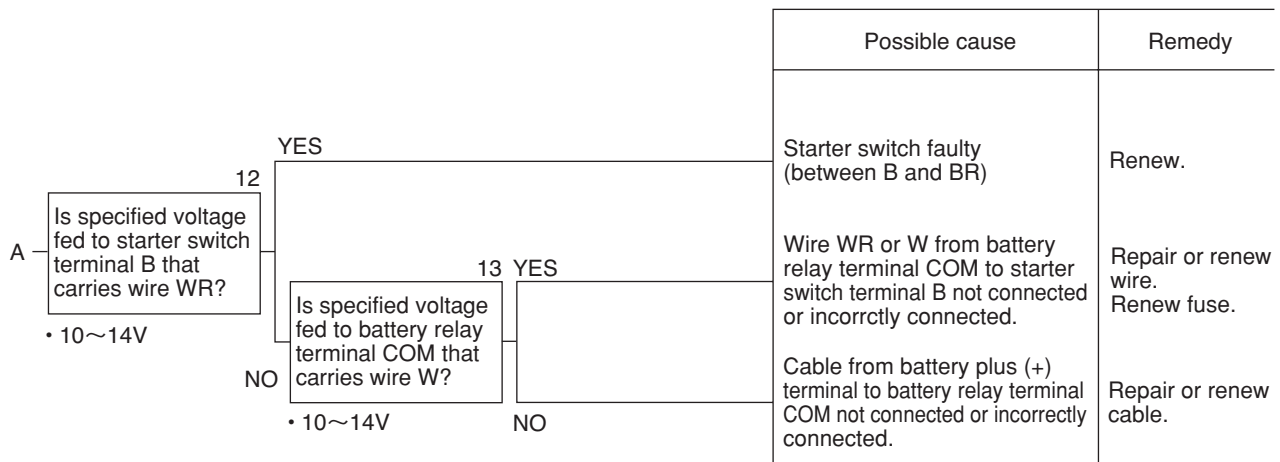

Electric wiring diagram for modes E-01 and E-02

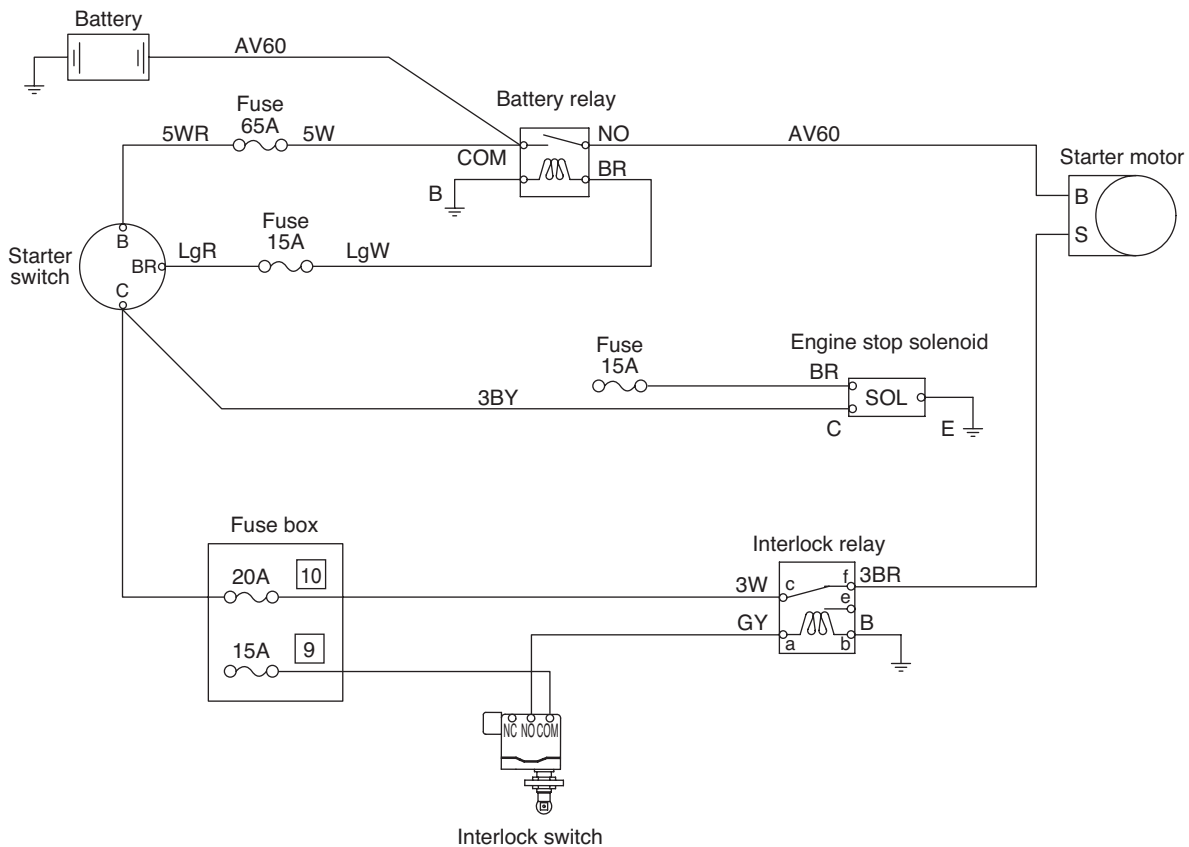

b) Engine stop solenoid does not operate (Starter runs.).

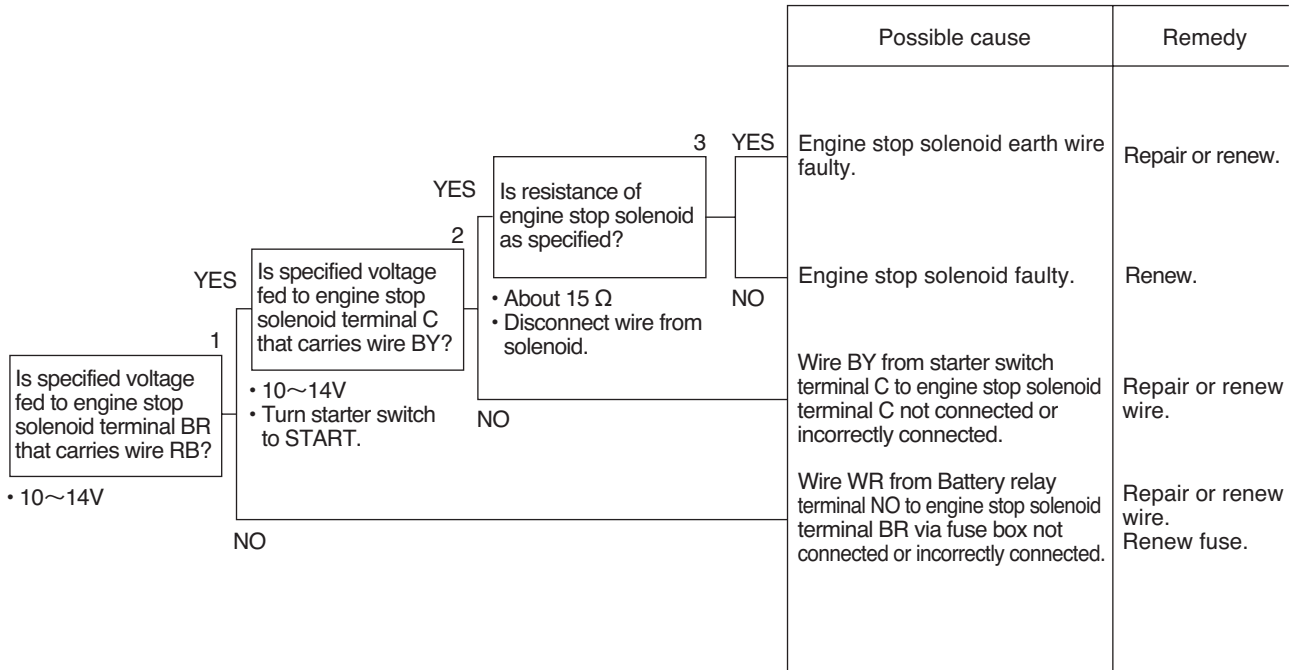

E-02 Engine does not stop

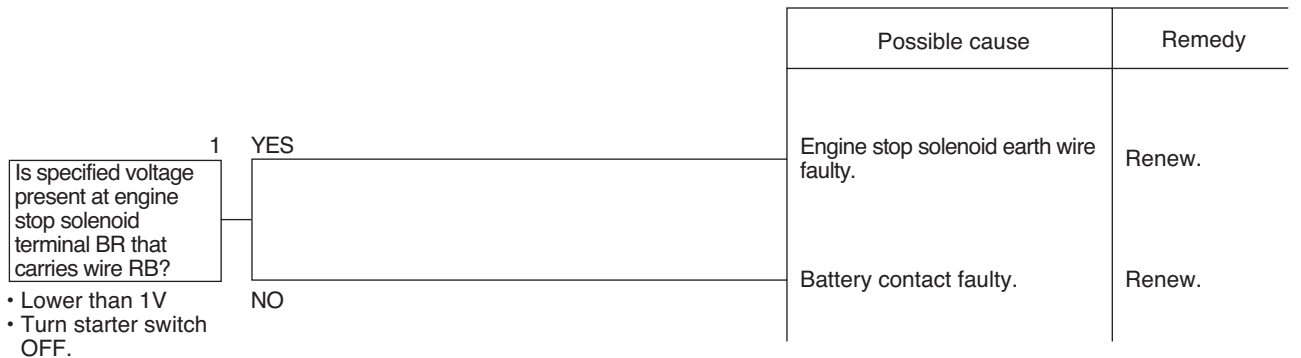

E-03 Glow Plugs do not become red-hot (difficult starting)

★ It is assumed that the starter revolution speed is normal.

★ Check for blown fuse first.

★ Measure the voltage with the starter switch ON.

a) Glow indicator does not become bright. (Lamps work normally.)

★ The glow indicator should become bright when the starter switch is turned to the HEAT position, and come off when preheating is complete.

		Possible cause	Remedy	
<p>1</p> <p>Does stated voltage appear at glow indicator timer connector terminal 4 that carries wire WG?</p> <p>• 10~14V • Turn starter switch to HEAT.</p>	YES	<p>2</p> <p>Does stated voltage appear at glow indicator timer connector terminal 6 that carries wire YW?</p> <p>• 10~14V • Turn starter switch ON. • Heating: Lower than 1V</p>	<p>2</p> <p>Glow indicator relay faulty.</p> <p>Renew.</p>	
	NO			<p>3</p> <p>Does stated voltage appear at combination meter terminal that carries wire YW?</p> <p>• 10~14V</p>
	NO	YES	<p>4</p> <p>Does stated voltage appear at starter switch terminal R1 that carries wire WG?</p> <p>• 10~14V</p>	
		NO	NO	<p>4</p> <p>Starter switch faulty. (between B and R1)</p>
b) Glow indicator becomes bright but engine is hard to start.				
<p>1</p> <p>Does stated voltage appear at glow plug terminal that carries wire WG?</p> <p>• 10~14V • Turn starter switch to HEAT.</p>	YES	Glow plugs faulty.	Renew.	
	NO	Wire WG from starter switch terminal R1 to glow plugs not connected or incorrectly connected.	Repair or renew wire.	

Electric wiring diagram for mode E-03

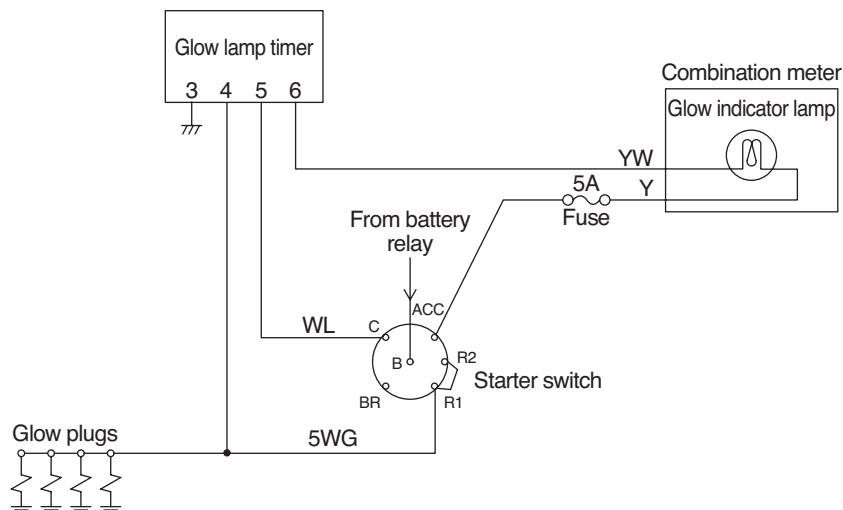

* SW352, TW352 and TW502 have three glow plugs.

E-04 No charging (charge indicator lamp on monitor display comes on)

- ★ Check that fuse is not damaged.
- ★ Measure the voltage with the starter switch ON.

		Possible cause	Remedy	
<p>1</p> <p>Does specified voltage appear at alternator terminal IG that carries wire Y?</p> <p>• 13.5~14.5V • Run engine at above medium speed.</p>	YES	Regulator faulty.	Renew.	
	<p>2</p> <p>Does specified voltage appear at alternator terminal B that carries wire WY?</p> <p>• 10~14V</p>	YES	Alternator faulty.	Renew.
		NO	Wire WY from alternator terminal B to starter terminal B not connected or incorrectly connected.	Repair or renew wire.

Electric wiring diagram for mode E-04

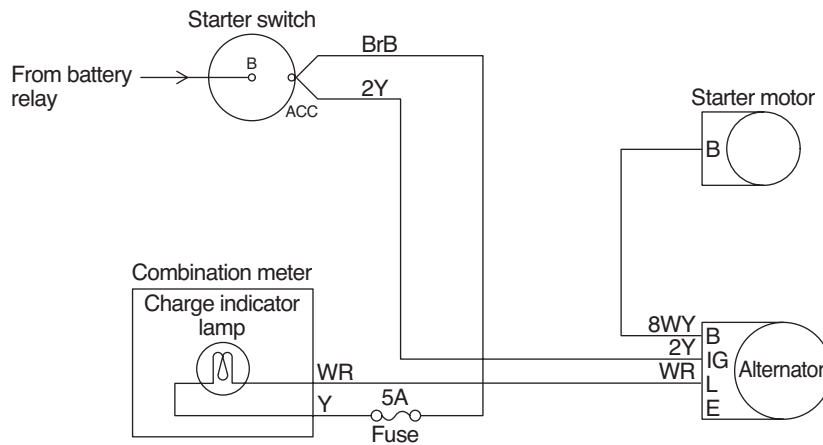

E-05 Fuel pump does not operate

- ★ Take the measurement of voltage with the starter witch ON.

		Possible cause	Remedy	
<p>1</p> <p>Does specified voltage appear at fuel pump terminal R that carries wire RB?</p> <p>• 10~14V</p>	YES	Fuel pump faulty.	Renew.	
	<p>2</p> <p>Is resistance of alternator ground wire as specified?</p> <p>• Lower than 1 Ω • Disconnect wire from alternator.</p>	YES	Fuel pump earth wire not connected or incorrectly connected.	Repair or renew wire.
		NO	Wire RB from fuse to fuel pump not connected or incorrectly connected.	Repair or renew wire.

Electric wiring diagram for mode E-05



E-06 Vibrator does not work

★ Ensure that fuse is not damaged first.

★ Measure the voltage with the starter switch ON.

SW352, TW352

a) Vibrator does not operate with on-off switch on top of F-R lever actuated.

★ Make a diagnosis with MANUAL mode selected.

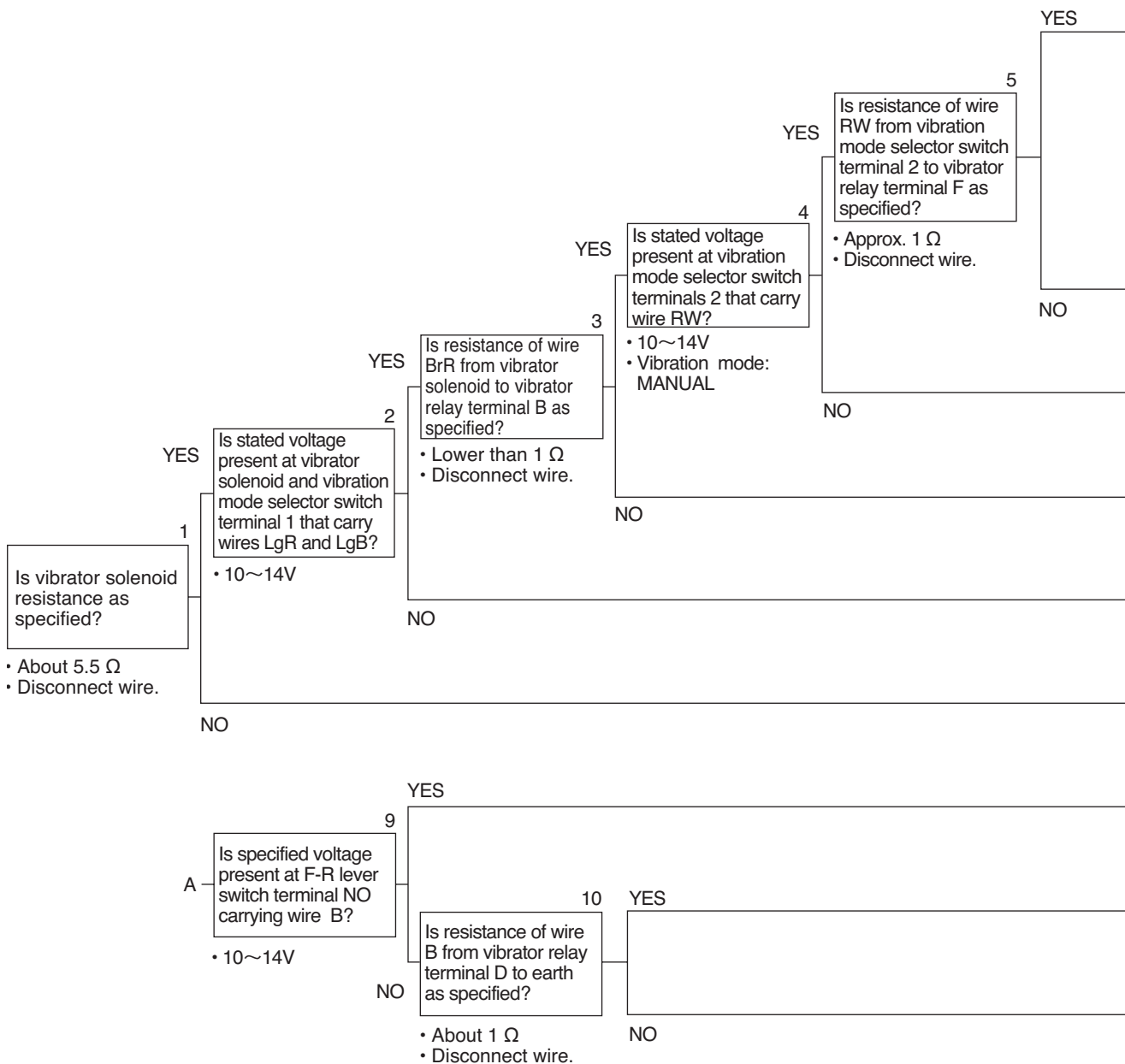

		Possible cause	Remedy
6	YES	To "A" on page 4-208	
	NO	F-R lever switch earth wire not connected or incorrectly connected.	Repair or renew wire.
7	YES	Vibrator relay faulty.	Renew.
	NO	Wire Br from F-R lever switch terminal C to vibrator relay terminal H not connected or incorrectly connected.	Repair or renew wire.
8	YES	Wire RW from vibration mode selector switch terminal 2 to vibrator relay terminal F not connected or incorrectly connected.	Repair or renew wire.
	NO	Vibration mode selector switch faulty.	Renew.
		Wire BrR from vibrator solenoid to vibrator relay terminal B not connected or incorrectly connected.	Repair or renew wire.
		Any wire RL, LgR or LgB running between vibration mode selector switch terminal 1, vibrator solenoids and fuse not connected or incorrectly connected.	Repair or renew wire.
		Vibrator solenoid faulty.	Renew.
		F-R lever switch faulty.	Renew.
		Vibrataor relay faulty.	Renew.
		Vibrator relay earth wire B not connected or incorrectly connected.	Repair or renew wire.

Is stated voltage present at F-R lever switch terminal C that carries wire Br?
• 10~14V

7 YES
Is resistance of F-R lever earth wire as specified?

- About 1 Ω
- Disconnect wire.

8 YES
Is resistance of wire Br from F-R lever switch terminal C to vibrator relay terminal H as specified?

- About 1 Ω
- Disconnect wire.

Fault Diagnosis of Electric System (Mode E)

SW502, TW502

a) Vibrator does not operate with on-off switch on top of F-R lever actuated.

★ Make a diagnosis with MANUAL mode and LOW amplitude or High amplitude selected.

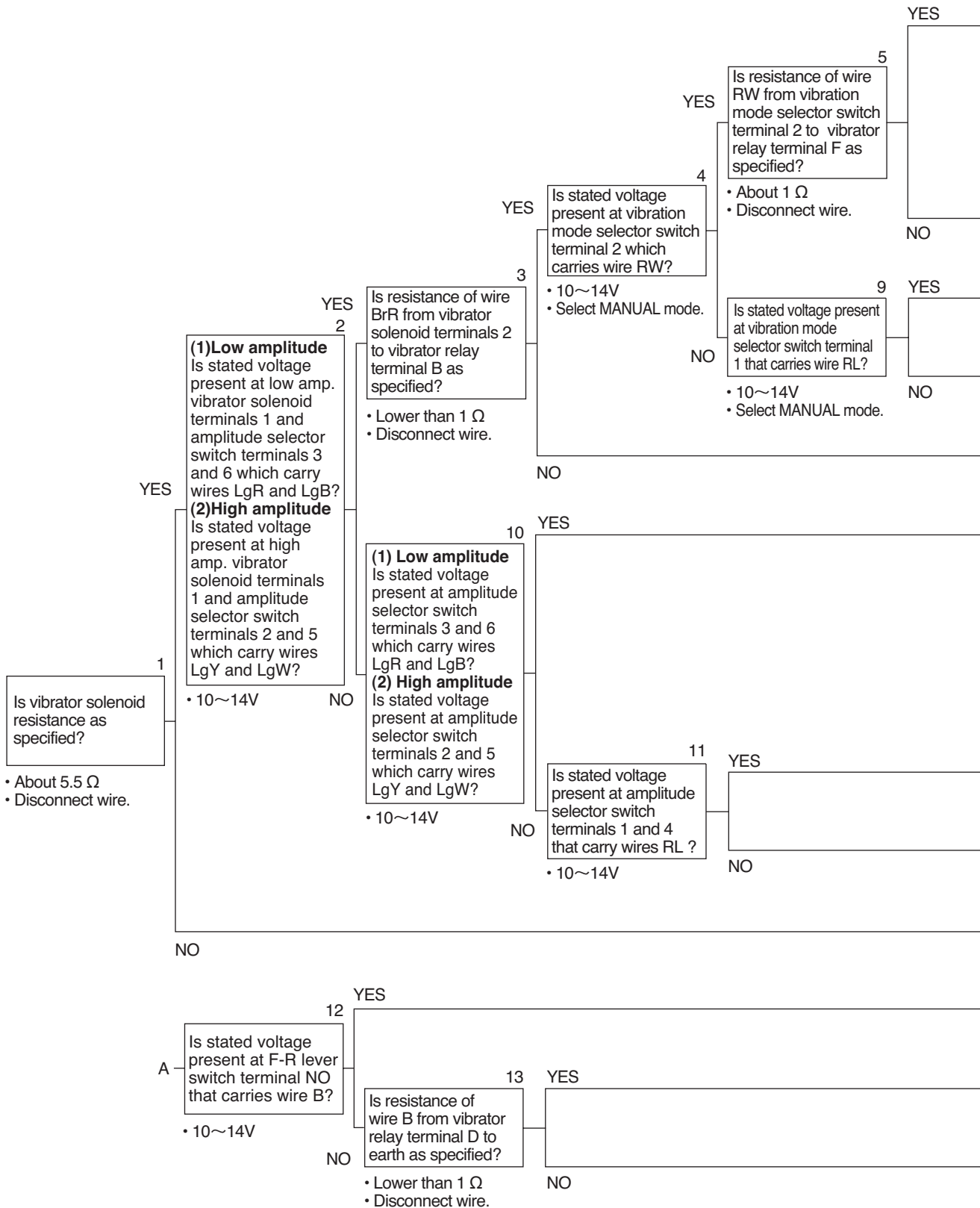

Fault Diagnosis of Electric System (Mode E)

	Possible cause	Remedy
<div style="display: flex; align-items: center;"> <div style="border: 1px solid black; padding: 5px; margin-right: 10px;"> Is stated voltage present at F-R lever switch terminal C that carries wire Br ? • 10~14V </div> <div style="margin-right: 10px;"> YES 6 </div> <div style="border: 1px solid black; padding: 5px; margin-right: 10px;"> Is resistance of F-R lever earth wire as specified ? </div> <div style="margin-right: 10px;"> YES 7 </div> <div style="border: 1px solid black; width: 80px; height: 30px;"></div> </div> <div style="margin-top: 10px;"> <div style="display: flex; align-items: center;"> <div style="margin-right: 10px;"> NO 6 </div> <div style="border: 1px solid black; padding: 5px; margin-right: 10px;"> Is resistance of wire Br from F-R lever switch terminal C to vibrator relay terminal H as specified? </div> <div style="margin-right: 10px;"> YES 8 </div> <div style="border: 1px solid black; width: 80px; height: 30px;"></div> </div> <div style="margin-top: 10px;"> <div style="display: flex; align-items: center;"> <div style="margin-right: 10px;"> NO 6 </div> <div style="margin-right: 10px;"> • About 1 Ω • Disconnect wire. </div> </div> </div> </div>	<p>To "A" on page 4-210</p> <p>Earth wire not connected or incorrectly connected.</p> <p>Vibrator relay faulty.</p> <p>Wire Br from F-R lever switch terminal C to vibrator relay terminal H not connected or incorrectly connected.</p> <p>Wire RW from vibration mode selector switch terminal 2 to vibrator relay terminal F not connected or incorrectly connected.</p> <p>Vibration mode selector switch faulty.</p> <p>Wire RL from vibration mode selector switch terminal 1 to fuse not connected or incorrectly connected.</p> <p>Wire BrR from Low amp. solenoid terminal 2 to vibrator relay terminal B not connected or incorrectly connected.</p> <p>(1) Low amplitude Wire LgR or LgB from amplitude selector switch terminal 3 or 6 to low amp. vibrator solenoid terminal 1 not connected or incorrectly connected.</p> <p>(2) High amplitude Wire LgY or LgW from amplitude selector switch terminal 2 or 5 to high amp. vibrator solenoid terminal 1 not connected or incorrectly connected.</p> <p>Amplitude selector switch faulty.</p> <p>Wires RL from amplitude selector switch terminals 1 and 4 to vibrator on-off switch terminals 1 and 4 not connected or incorrectly connected.</p> <p>Vibrator solenoid faulty.</p> <p>F-R lever switch faulty.</p> <p>Vibrator relay faulty.</p> <p>Vibrator relay earth wire B not connected or incorrectly conneced.</p>	<p>Repair or renew wire.</p> <p>Repair or renew wire.</p> <p>Repair or renew wire.</p> <p>Repair or renew wire.</p> <p>Repair or renew wire.</p> <p>Repair or renew wire.</p> <p>Repair or renew wire.</p> <p>Repair or renew wire.</p> <p>Repair or renew wire.</p> <p>Repair or renew wire.</p> <p>Repair or renew wire.</p> <p>Repair or renew wire.</p> <p>Repair or renew wire.</p> <p>Repair or renew wire.</p> <p>Repair or renew wire.</p> <p>Repair or renew wire.</p>

Fault Diagnosis of Electric System (Mode E)

b) Vibrator does not operate with AUTO mode but works by operation of F-R lever switch.

★ Make a diagnosis with AUTO mode selected.

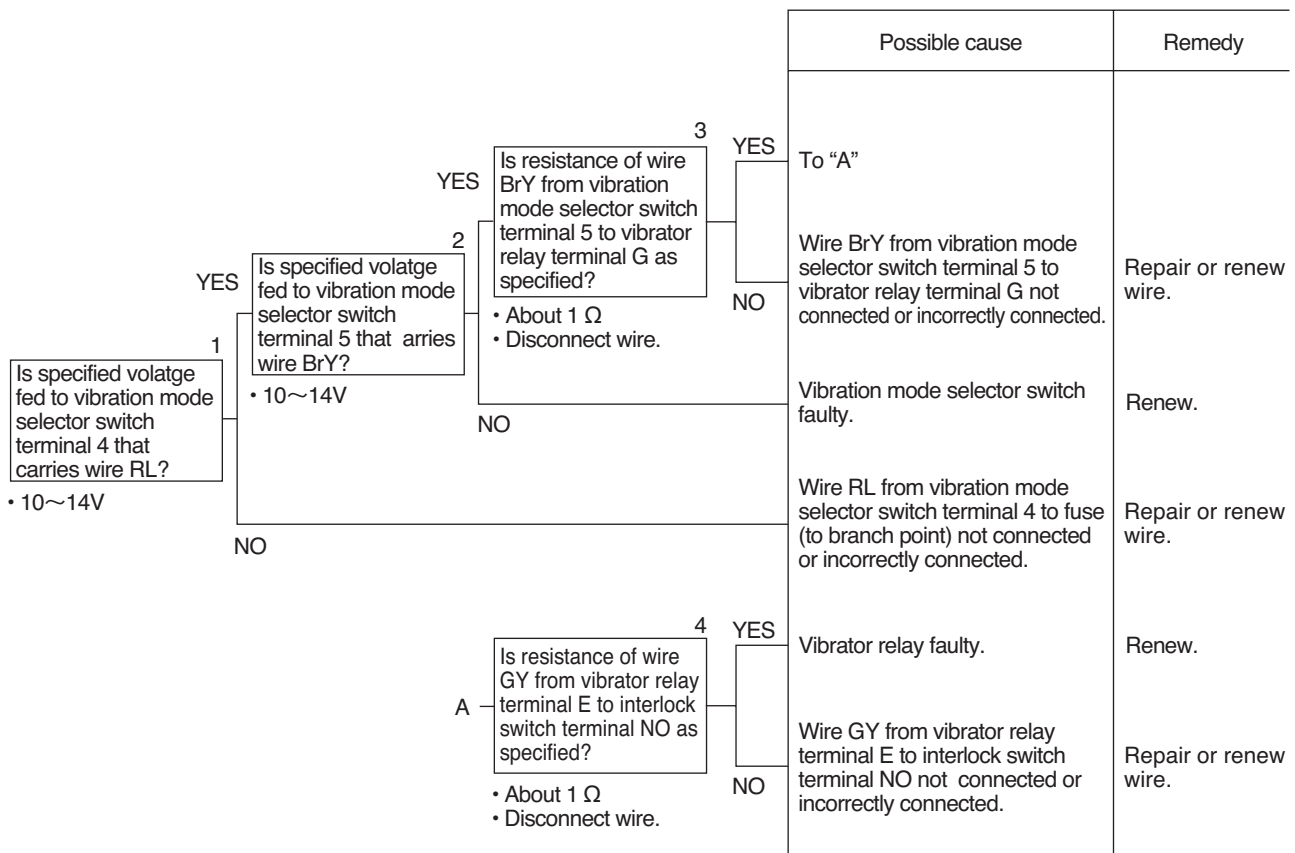

Electric wiring diagram for mode E-6 (SW352, TW352)

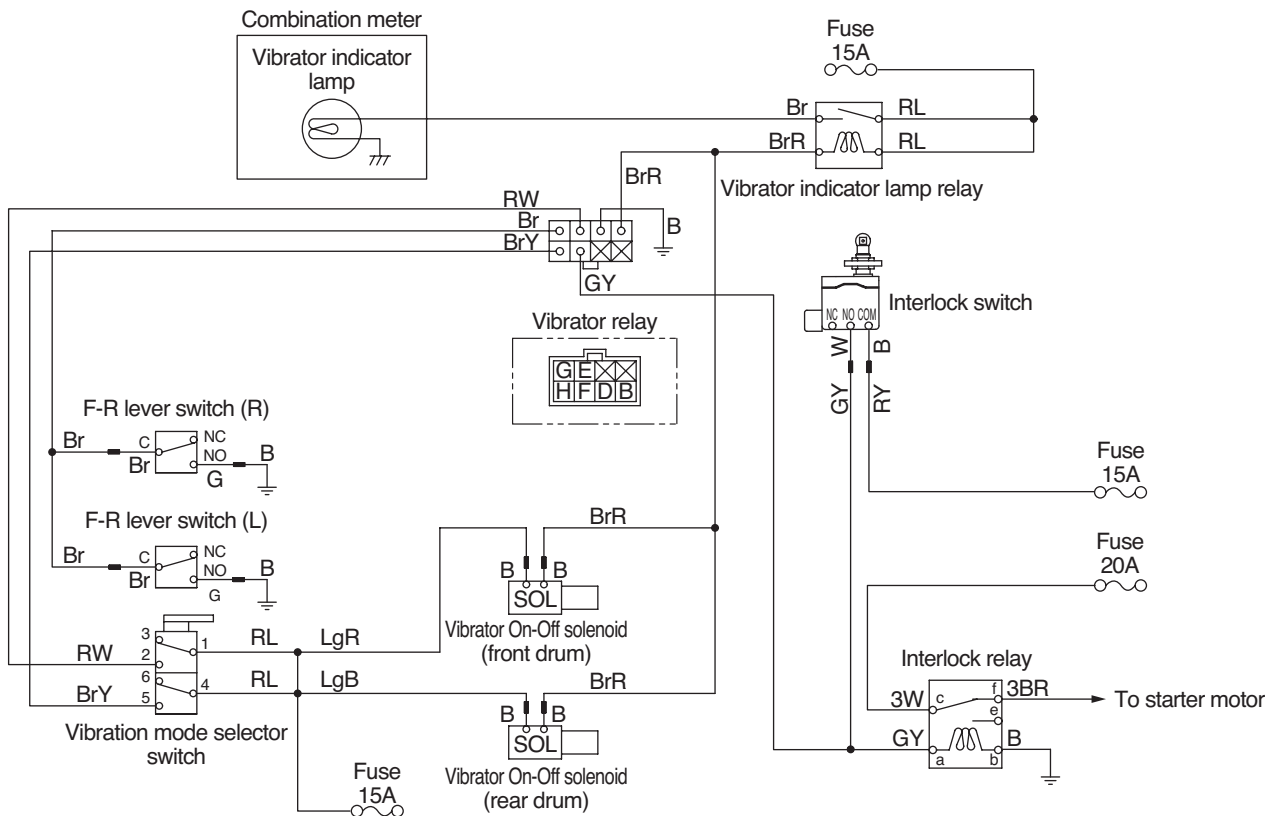

* Above figure illustrates diagram of SW352. TW352 has front vibrating unit only.

Electric wiring diagram for mode E-6 (SW502, TW502)

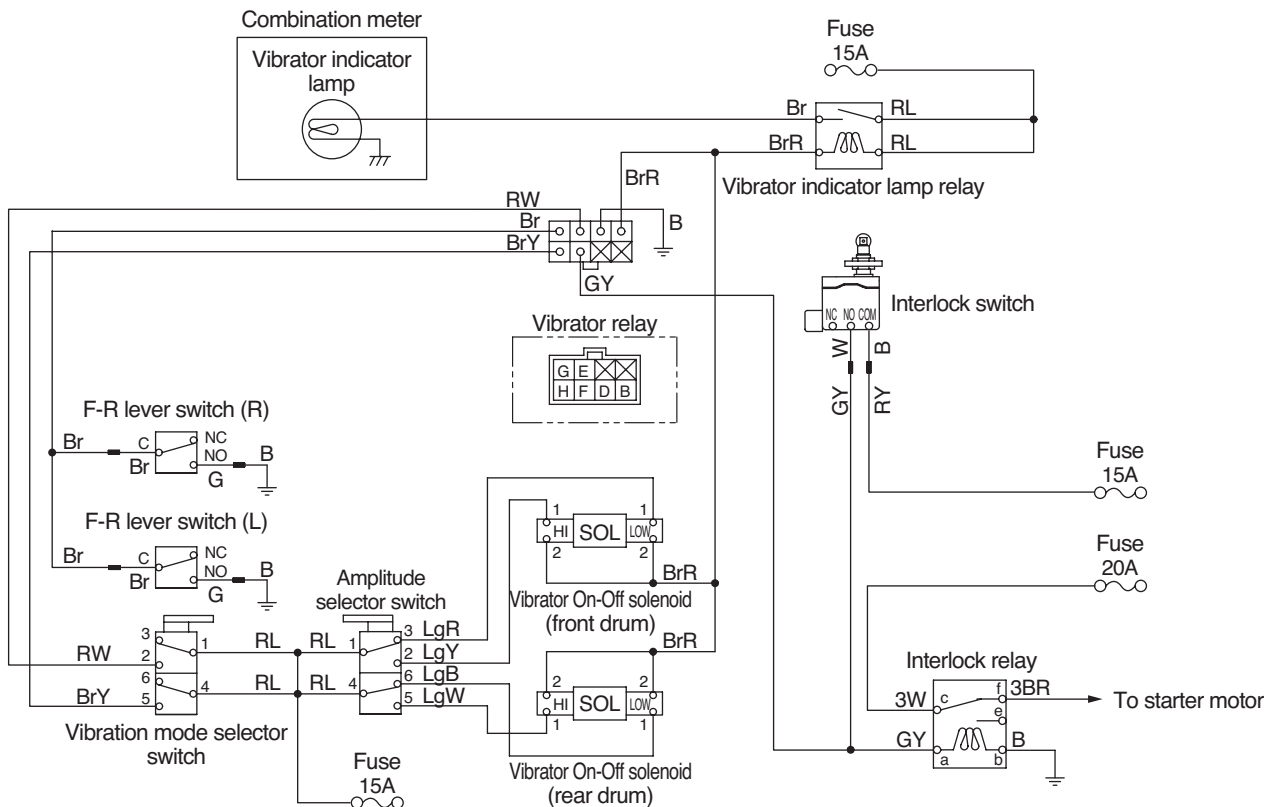

* Above figure illustrates diagram of SW502. TW502 has front vibrating unit only.

E-07 Sprinkler does not operate

★ Check for burnt fuse first.

★ Measure the voltage with starter switch ON.

		Possible cause	Remedy				
<p>1</p> <p>Is stated voltage fed to sprinkler motor that carries wire LB?</p> <ul style="list-style-type: none"> • 10~14V • Operate sprinkler switch. 	YES	2	YES	Sprinkler motor faulty.	Renew.		
			NO		Sprinkler motor earth wire not connected or incorrectly connected.	Repair or renew wire.	
	NO	3	YES		Wire LB from sprinkler relay to sprinkler motor not connected or incorrectly connected.	Repair or renew wire.	
				NO	4	YES	To "A"
<p>5</p> <p>Is stated voltage fed to sprinkler relay coil that carries wire LW?</p> <ul style="list-style-type: none"> • 10~14V • Operate sprinkler switch. 			NO	4	NO	Wire LY from fuse to sprinkler relay not connected or incorrectly connected.	Repair or renew wire.
	YES	6	YES		Sprinkler relay faulty.	Renew.	
				NO		Sprinkler relay earth wire not connected or incorrectly connected.	Repair or renew wire.
	NO	7	YES		Wire LW from sprinkler switch terminal 2 to sprinkler relay coil not connected or incorrectly connected.	Repair or renew wire.	
			NO	8	YES	Sprinkler switch faulty.	Renew.
			NO		NO	Wire LY from fuse to sprinkler switch terminal 1 not connected or incorrectly connected.	Repair or renew wire.

Electric wiring diagram for mode E-07

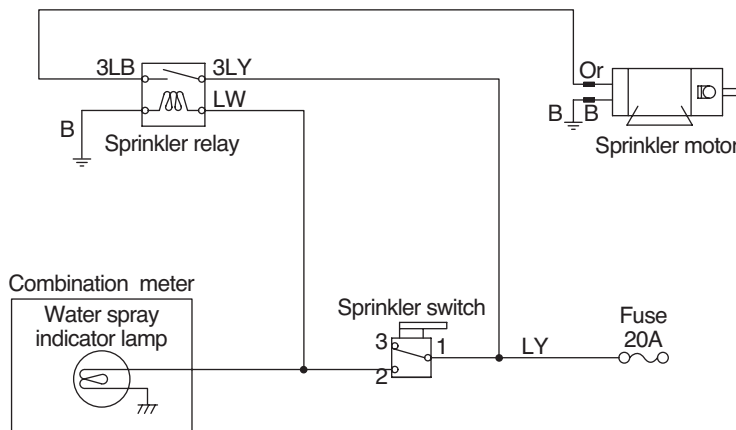

E-08 Low-High speed range selection is not available

★ Check for burnt fuse first.

★ Measure voltage with starter switch ON.

		Possible cause	Remedy		
<p>1</p> <p>Is stated voltage fed to speed selector solenoid that carries wire LgW?</p> <ul style="list-style-type: none"> • 10~14V • Operate speed selector switch. 	YES	<p>2</p> <p>Is solenoid resistance as specified and is solenoid insulated from machine body?</p> <ul style="list-style-type: none"> • About 8.5 Ω • Disconnect wire at solenoid. 			
	NO			<p>4</p> <p>Is stated voltage fed to speed selector switch terminal 2 that carries wire LgW?</p> <ul style="list-style-type: none"> • 10~14V • Operate speed selector switch. 	
	YES	<p>3</p> <p>Is resistance of solenoid earth wire as specified?</p> <ul style="list-style-type: none"> • Lower than 1 Ω • Disconnect wire from solenoid. 	<p>YES</p> <p>Hydraulic system faulty. (See H-03.)</p>		
	NO		<p>NO</p> <p>Solenoid earth wire not connected or incorrectly connected.</p>		
	YES		<p>NO</p> <p>Speed selector solenoid faulty.</p>		
NO		<p>5</p> <p>Is stated voltage fed to speed selector switch terminal 1 that carries wire RY?</p> <ul style="list-style-type: none"> • 10~14V 	<p>YES</p> <p>Speed selector switch faulty.</p>		
			<p>NO</p> <p>Wire RY from fuse to speed selector switch terminal 1 not connected or incorrectly connected.</p>		

Electric wiring diagram for mode E-08

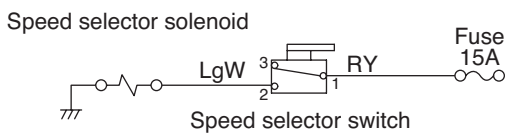

E-09 Parking brake is not released

★ Check for burnt fuse first.

★ Measure the voltage with the starter switch ON.

★ Make a diagnosis with the parking brake switch in the RELEASE position, and the brake pedal not depressed.

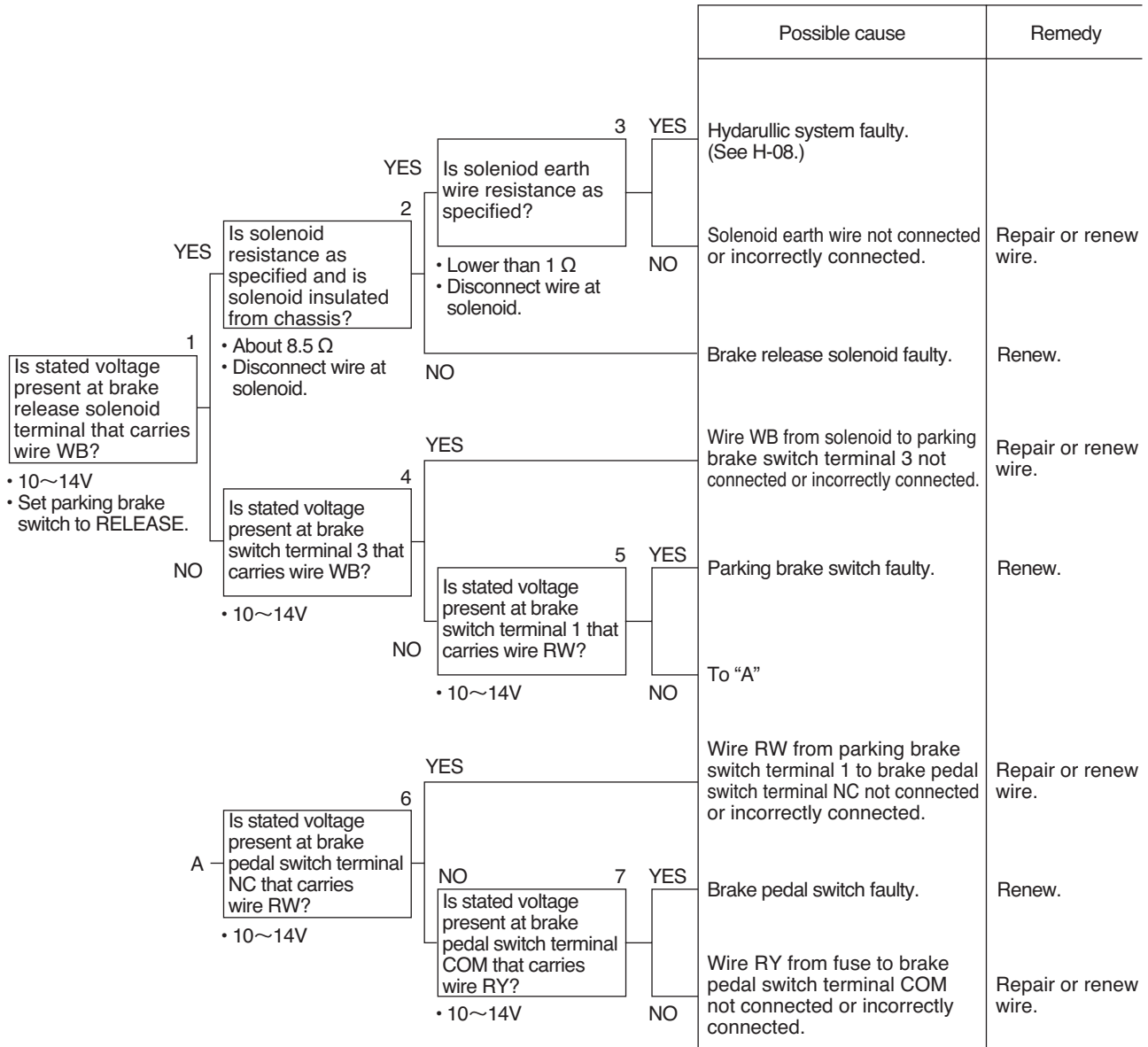

Electric wiring diagram for mode E-09

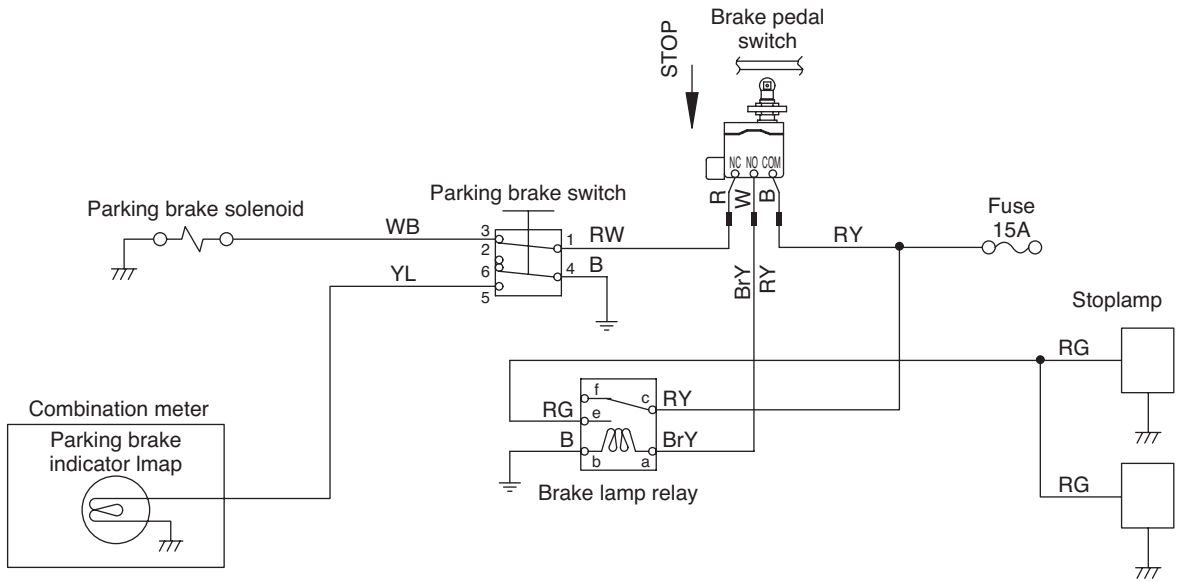

6. Fault Diagnosis of Hydraulic and Mechanical Systems (Mode H)

H-01 Not Propelled	4-404
H-02 Speed not Gained or Low Traction	4-406
H-03 Speed Range not Selected	4-406
H-04 Vibrator Inoperative	4-407
H-05 Low Vibration Intensity	4-408
H-06 Steering not Achieved	4-408
H-07 Heavy or Slow Steering	4-409
H-08 Parking Brake not Released	4-409
H-09 Poor Parking Brake Function	4-410

* See STANDARD VALUE CHART for hydraulic pressure measurement.

Mechanical system diagnosis mode and units with possible source of trouble

Units with possible source of trouble		Fault mode	Propulsion				Speed range not selected
			Not propelled		Speed not gained or low traction		
			a) Forward and backward	b) Either forward or backward	a) Forward and backward	b) Either forward or backward	
Propulsion	Pump	Pump (including servo piston)	●		●		
		Control valve	●	●	●	●	
		Multi-function valve				●	
		Charge relief valve	●				
	Front drive	Motor body	●		●		
		Negative brake					
		Flushing valve	●		●		
		Speed selector valve or selector piston					●
	Rear drive (SW)	Motor body	●		●		
		Negative brake					
	Rear drive (TW)	Motor body	●		●		
		Negative brake					
		Speed selector solenoid valve					●
	Brake release solenoid valve	●					
Vibrator	Pump						
	Vibrator on-off solenoid valve						
	Amplitude selector solenoid valve						
	Pressure relief valve						
	Front motor						
	Front vibrator						
	Rear motor*						
	Rear vibrator*						
Steering	Steering/charge pump	●					
	Steering valve (Orbitrol)						
	Steering cylinder						
	Steering mechanism						
Others	Coupling						
	F-R lever linkage	●	●	●	●		
	Engine			●			
	Diagnosis code	H-01a	H-01b	H-02a	H-02b	H-03	

* For SW352, SW502

Fault Diagnosis of Hydraulic and Mechanical Systems (Mode H)

Vibrator					Steering		Parking brake not released	Poor parking brake function
Inoperative (SW/TW352)		Inoperative (SW/TW502)		Low vibration intensity	Not achieved	Heavy or slow		
a) Front and rear	b) Either front or rear	a) Front and rear	b) Either front or rear	Either front or rear				
							●	●
							●	●
							●	●
							●	●
●		●						
●	●			●				
		●	●	●				
●		●						
	●		●	●				
	●		●	●				
	●		●	●				
	●		●	●				
					●	●		
					●	●		
					●	●		
					●	●		
●		●						
H-04a	H-04b	H-04a	H-04b	H-05	H-06	H-07	H-08	H-09

H-01 Not propelled

★ Make a diagnosis on electric systems first. If they are normal, then use the following procedures.

★ Check the oil level in the hydraulic tank first.

a) Propelled in neither direction
(neither forward nor backward).

		Possible cause	Remedy	
<p>1 Does steering system work correctly?</p> <p>YES</p> <p>2 Does unload valve stay closed?</p> <p>YES</p> <p>3 Is F-R lever movement normal?</p> <p>YES</p> <p>4 Do pump servo valve and servo linkage work correctly?</p> <p>YES</p>	NO	To "A"		
	NO	NO	Servo valve & servo linkage are malfunctioning.	Repair or renew.
	NO	NO	F-R lever linkage is malfunctioning.	Adjust.
	NO	NO	Unloader valve remains open.	Close
<p>5 Is charge pressure in propulsion line as specified? *See Standard Value Chart.</p> <p>YES</p> <p>6 Is charge pressure as specified with F-R lever moved forward and backward? *See Standard Value Chart.</p> <p>YES</p> <p>7 Is brake release pressure of solenoid valve as specified? *See Standard Value Chart.</p> <p>YES</p>	NO	To "B"		
	NO	NO	Brake release solenoid valve is malfunctioning.	Repair or renew.
	NO	NO	Low pressure relief valve built in flushing valve faulty or steering/charge pump performance degraded.	Disassemble, clean or adjust. Renew as necessary.
	NO	NO	Charge relief valve faulty or steering/charge pump performance degraded.	Disassemble, clean or adjust. Renew as necessary.
<p>8 Is machine propelled after releasing negative brake with release bolt screwed into it?</p> <p>YES</p> <p>9 Does rear propulsion motor run if ports A and B of front motor blocked? • Run engine at low idle. • Keep rear of machine lifted.</p> <p>YES</p> <p>10 Does front propulsion motor run if ports A and B of rear motor blocked? • Run engine at low idle. • Keep front of machine lifted.</p> <p>YES</p>	NO	Negative brake faulty.	Repair or renew.	
	NO	NO	Front motor faulty.	Repair or renew.
	NO	NO	Rear motor faulty.	Repair or renew.
	NO	NO	Propulsion pump faulty.	Repair or renew.

b) Machine travels in one direction alone, either forward or in reverse.

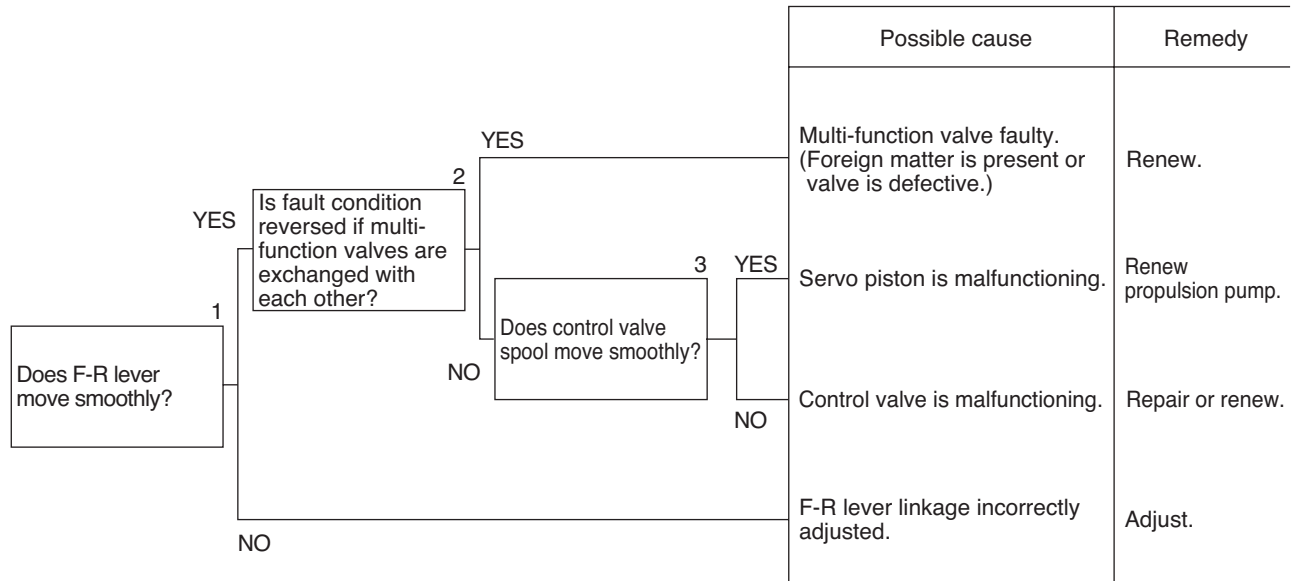

H-02 Speed not Gained or Low Traction

a) Speed gained in neither direction (neither forward nor backward).

★ Make sure that the unloader valve stays closed.

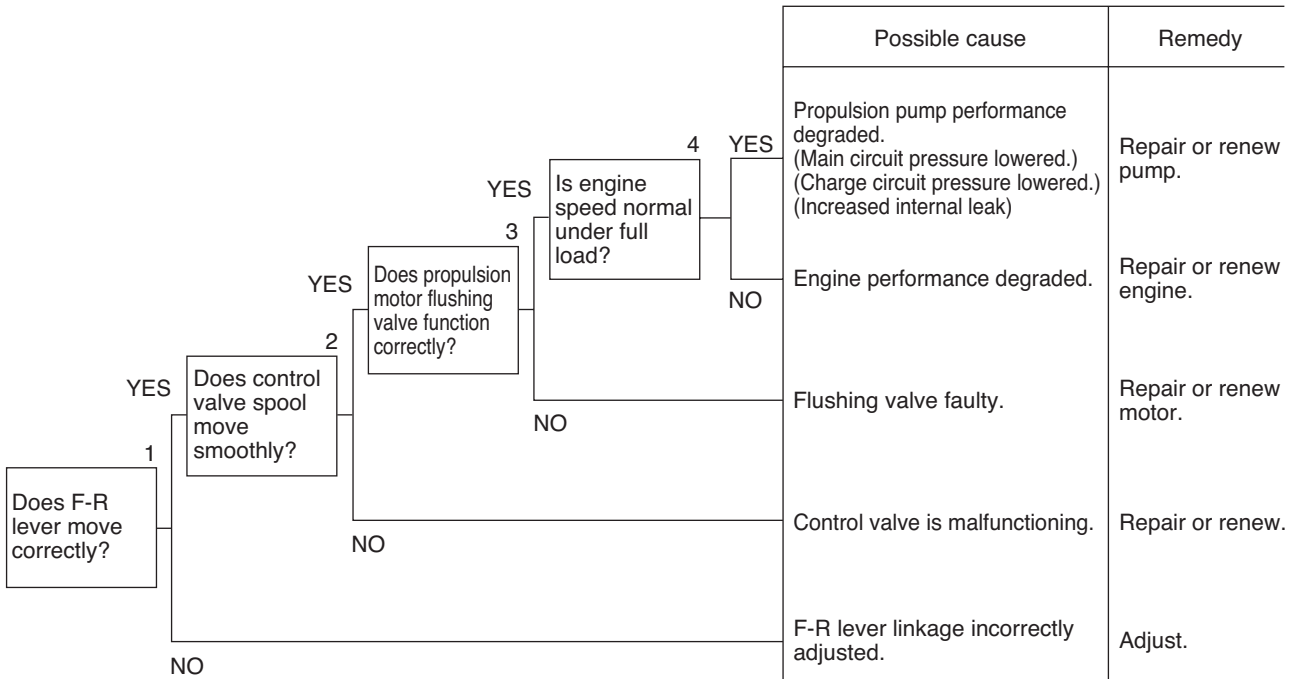

b) Speed is not gained either traveling forward or backing.

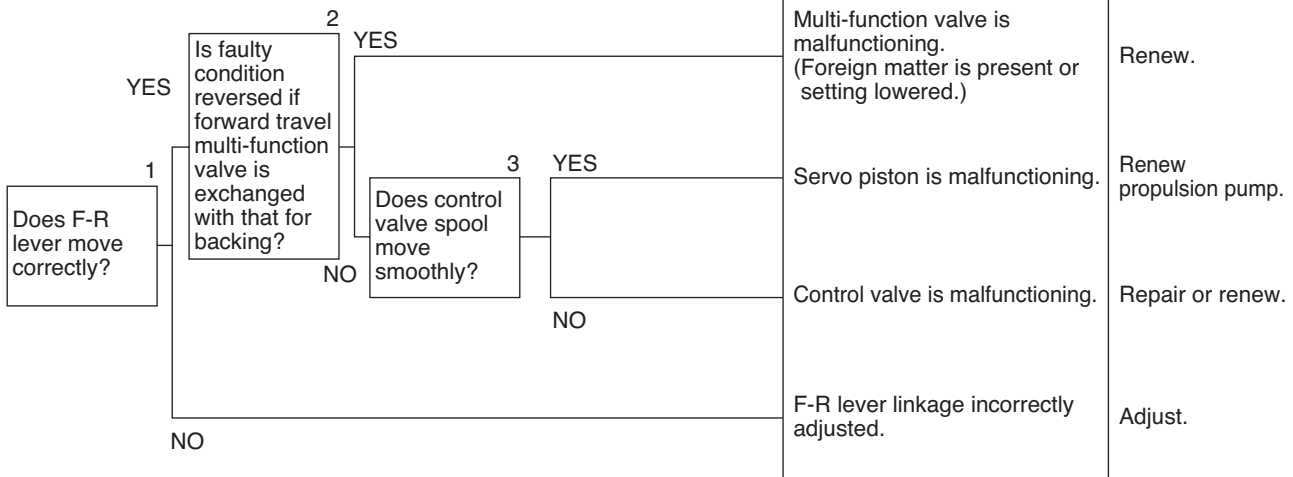

H-03 Speed Range not Selected

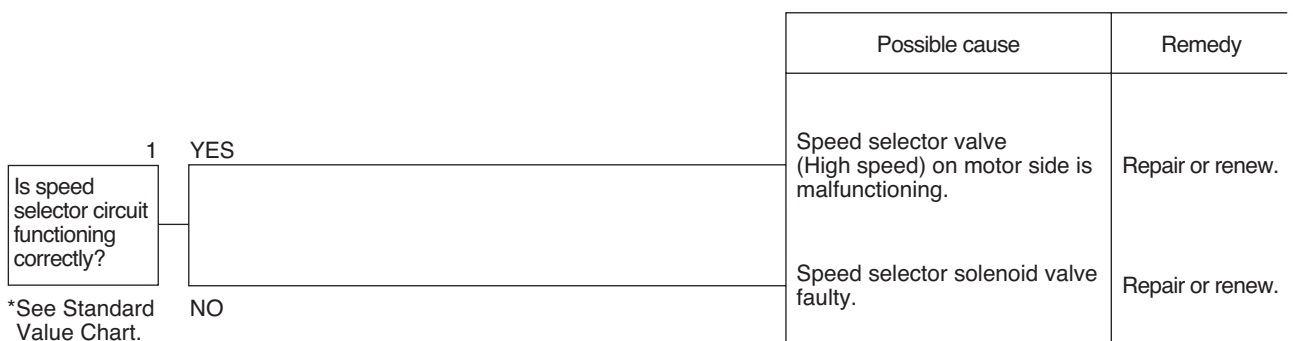

H-04 Vibrator Inoperative

★ Make a diagnosis of electric systems first. If they are normal, then use procedures as instructed below:

SW352, TW352

a) Vibrator inoperative at both High and Low amplitudes.

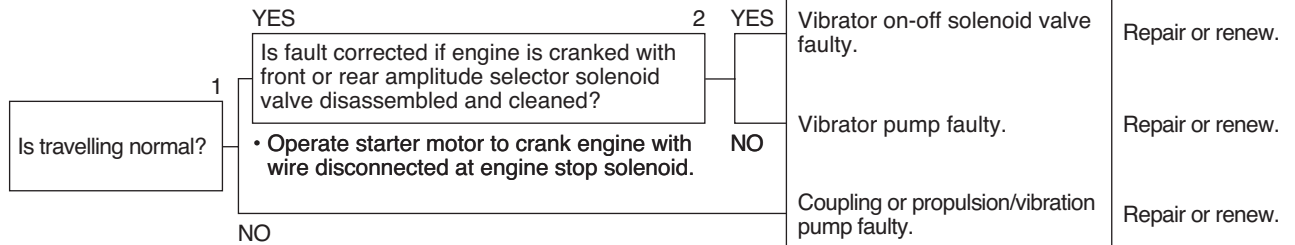

b) Either front or rear vibrator is inoperative.



SW502, TW502

a) Both front and rear vibrators are inoperative.

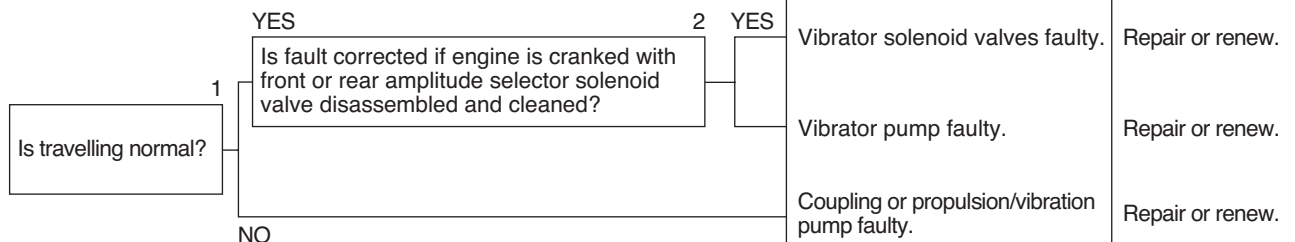

b) Either front or rear vibrator is inoperative.

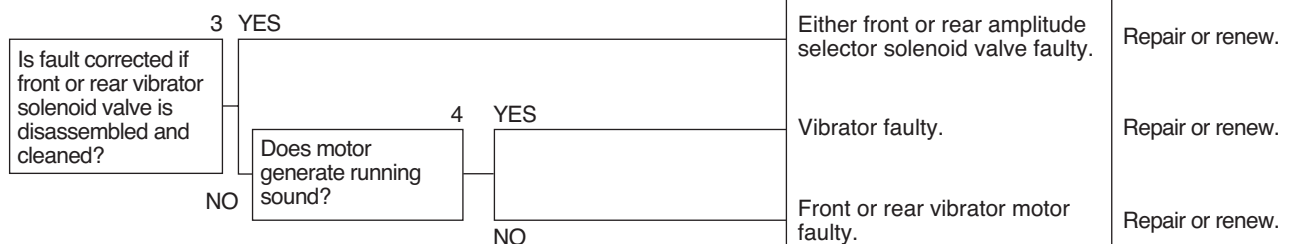

H-05 Low Vibration Intensity

★ Inspect electric systems first. If normal then use procedure as described below.

★ Low vibration intensity either in front or rear drum.

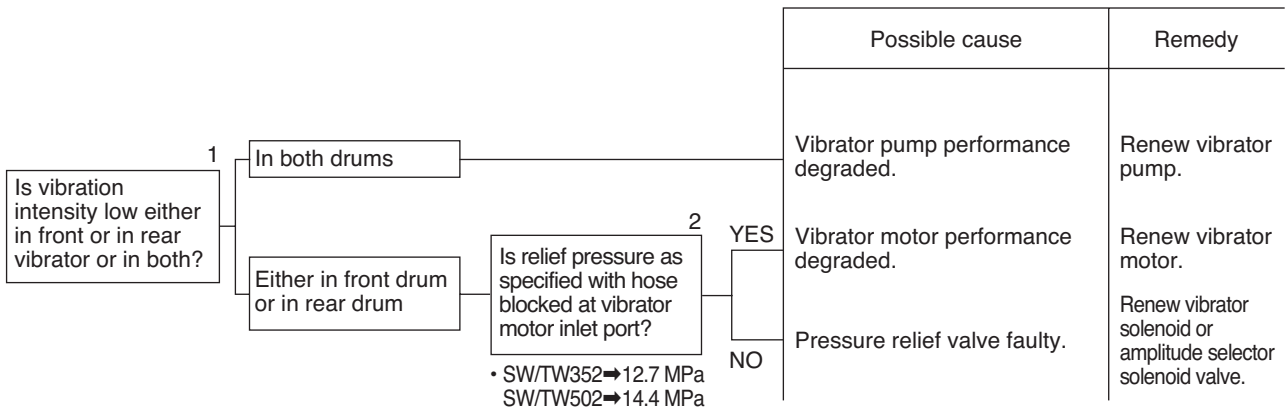

H-06 Steering not Achieved

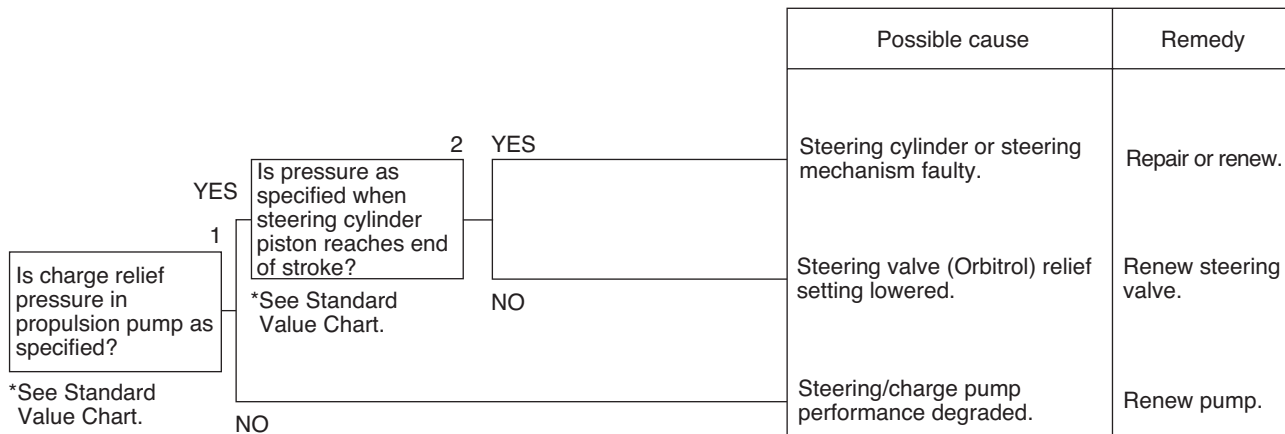

H-07 Heavy or Slow Steering

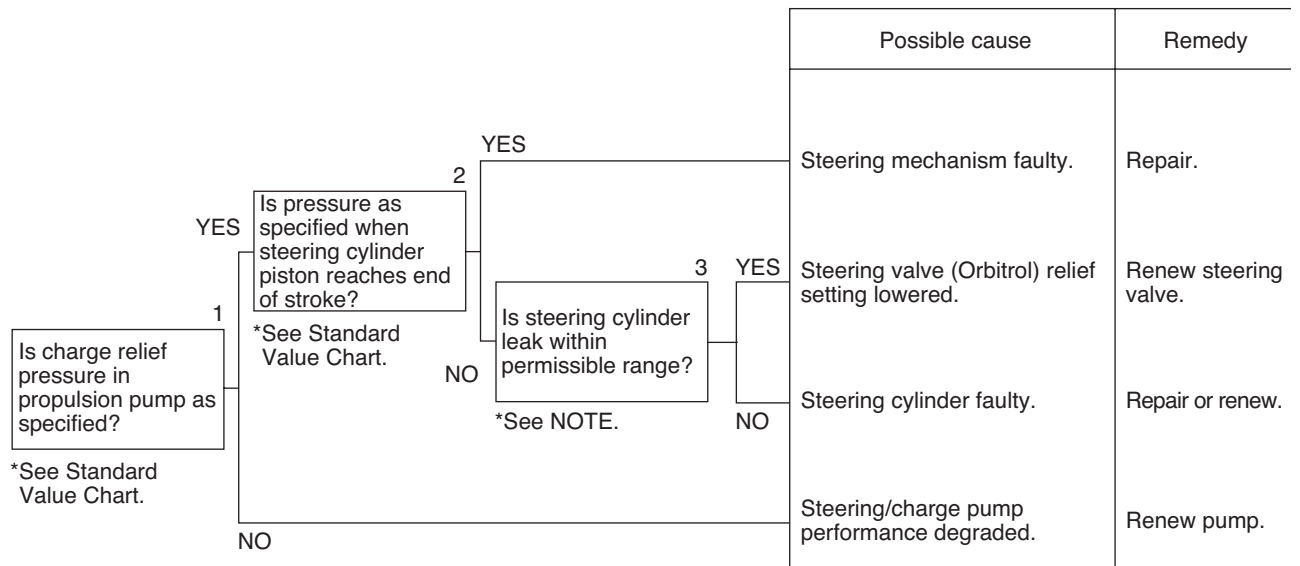

NOTE: Move steering cylinder piston to end of stroke, disconnect hose at stroke end side and put pressure from reverse side.

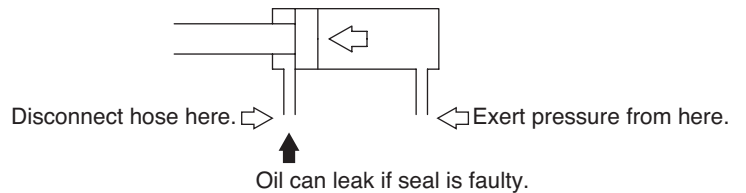

H-08 Parking Brake not Released

★ Make a diagnosis of electric systems first. If they are normal, use procedures as below:

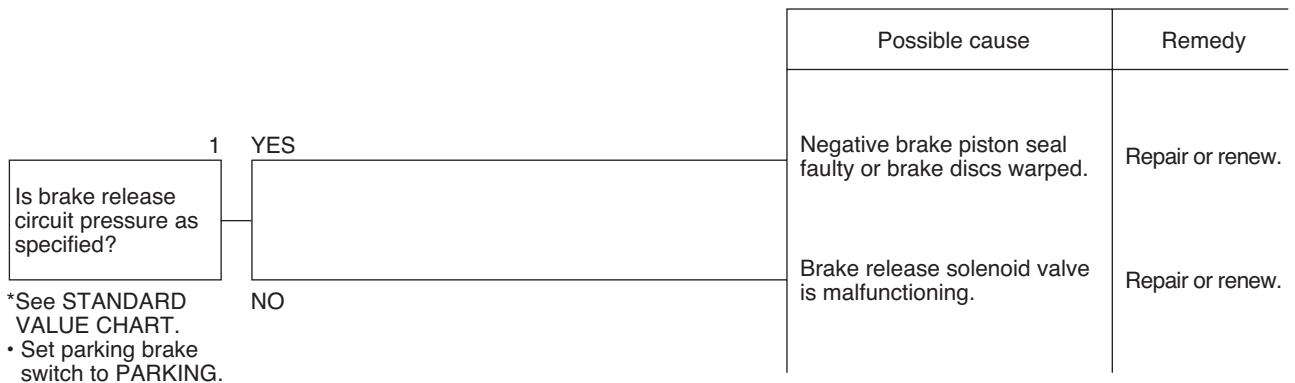

H-09 Poor Parking Brake Function

★ Make a diagnosis of electric systems first. If they are normal, then use the flow chart below:

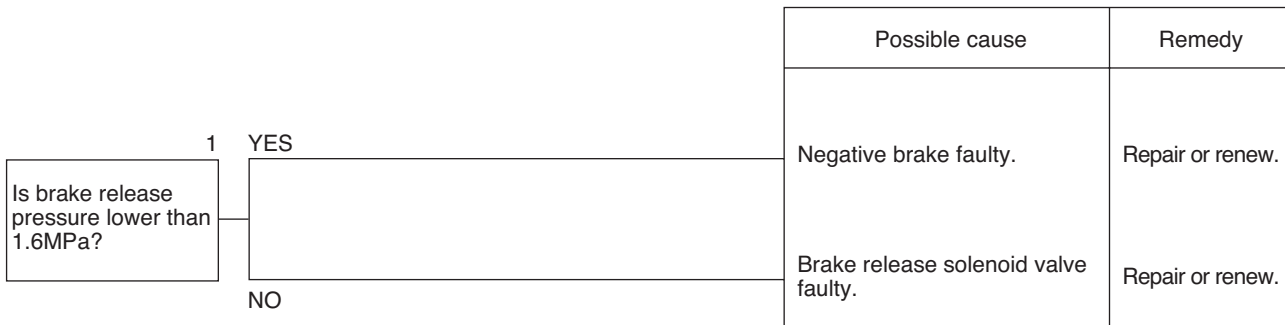

DISASSEMBLY AND ASSEMBLY

DISASSEMBLY AND ASSEMBLY

Precautions for Work	5-003
1. Removal and Installation of Alternator Assembly	
1-1. Removal of alternator assembly	5-101
1-2. Installation of alternator assembly	5-101
2. Removal and Installation of Starter Assembly	
2-1. Removal of starter assembly	5-102
2-2. Installation of starter assembly	5-102
3. Removal and Installation of Radiator/Oil Cooler Assembly	
3-1. Removal of radiator/oil cooler assembly	5-103
3-2. Installation of radiator/oil cooler assembly	5-103
4. Removal and Installation of Engine and Propulsion/Vibrator/Steering/Charge Pump Assembly	
4-1. Removal of engine and propulsion/vibration/steering/charge pump assembly	5-104
4-2. Installation of engine and propulsion/vibration/steering/charge pump assembly	5-107
5. Removal and Installation of Coupling	
5-1. Removal of coupling	5-108
5-2. Installation of coupling	5-108
6. Removal and Installation of Front Drum Assembly	
6-1. Removal of front drum assembly	5-109
6-2. Installation of front drum assembly	5-111
7. Disassembly and Assembly of Front Drum Assembly	
7-1. Disassembly of front drum assembly	5-112
7-2. Assembly of front drum assembly	5-115
8. Removal and Installation of Center Pin Assembly	
8-1. Removal of center pin assembly	5-119
8-2. Installation of center pin assembly	5-121
9. Removal and Installation of Rear Propulsion Motor Assembly and Wheels (TW352, TW502)	
9-1. Removal of rear propulsion motor assembly and wheels	5-122
9-2. Installation of rear propulsion motor assembly and wheels	5-124

10. Removal and Installation of	
Propulsion/Vibration/Steering/Charge Pump Assembly (SW352, SW502)	
10-1. Removal of propulsion/vibration/steering/charge pump assembly	5-125
10-2. Installation of propulsion/vibration/steering/charge pump assembly	5-125
11. Removal and Installation of Vibrator Pump Assembly (SW352, SW502)	
11-1. Removal of vibrator pump assembly	5-126
11-2. Installation of vibrator pump assembly	5-126
12. Removal and Installation of Vibrator Motor Assembly	
12-1. Removal of vibrator motor assembly	5-127
12-2. Installation of vibrator motor assembly	5-127
13. Disassembly and Assembly of Propulsion Motor Negative Brake	
13-1. Disassembly of propulsion motor negative brake	5-128
13-2. Assembly of propulsion motor negative brake	5-130
14. Removal and Installation of Steering Cylinder Assembly	
14-1. Removal of steering cylinder assembly	5-138
14-2. Installation of steering cylinder assembly	5-139
15. Disassembly and Assembly of Steering Cylinder Assembly	
15-1. Disassembly of steering cylinder assembly	5-140
15-2. Assembly of steering cylinder assembly	5-141
16. Removal and Installation of Steering Wheel	
16-1. Removal of steering wheel	5-142
16-2. Installation of steering wheel	5-142
17. Removal and Installation of Orbitrol	
17-1. Removal of Orbitrol	5-143
17-2. Installation of Orbitrol	5-143

Precautions for Work

★ When removing, disassembling, assembling and installing the units, follow the general precautions as described below:

1. Precautions for removal

- The coolant which contains an antifreeze should be treated carefully and must not be drained carelessly on the ground.
- Plug open end of disconnected hoses and pipes to prevent entry of dust.
- When draining oil, use a container of sufficient capacity to receive it.
- When disassembling parts, scribe match marks for correct reinstallation.
- When disconnecting wire connectors, pull connector, not wire, to avoid undue stress on the wire.
- Label wires and hoses for correct reconnection.
- When removing shims, note their number and thickness.
- When lifting parts or units, use a lifting gear of sufficient capacity.
- When separating parts by using pull bolts, screw in them alternately.
- When removing units, clean around them. After removal, cover them to prevent ingress of dust.

2. Precautions for installation

- Torque tighten bolts and nuts to specification.
- Install hoses exercising caution not to distort them or not to allow them to interfere with other parts.
- If once removed, discard gaskets, O-rings, cotter pins and lock plates.
- When installing, bend cotter pins and lock plates positively.
- If a sealant is coated, clean and remove residual oil or grease from thread portions. Apply two or three drops of bond to the threaded portions.
- When applying a sealant, clean and remove residual oil or grease from the mating surfaces. Spread the sealant smoothly after making sure that the surface is free from dust or not damaged.
- Clean parts. Correct scores, remove burrs and rusts etc.
- Apply a coat of engine oil to rotating and sliding portions.
- Apply a coat of grease to surfaces of press-fit parts.
- Make sure that lock rings are correctly seated in grooves.
- Connect wire connectors positively after removing oil, dust and water.
- Use lifting bolts not fatigued and not distorted. Screw in fully.
- When tightening parts such as split flange, tighten screws alternately to prevent one-sided tightening.

3. Precautions when service work is complete

- If coolant has been drained, refit the drain cock, fill coolant to the specified level. Start the engine, allow the coolant to circulate through the cooling system piping. Then add coolant to the specified level.
- If hydraulic units have been reinstalled or renewed, fill the hydraulic tank to the specified level. Start the engine, and allow the oil to circulate through the piping. Then add oil to the specified level.

1. Removal and Installation of Alternator Assembly

1-1. Removal of alternator assembly

⚠ Disconnect the negative (-) cable from the battery.

1. Engine hood

- 1) Open the engine hood.
- 2) Remove the fan belt cover.

2. Electric wiring of alternator

Disconnect connector (1) and wire (2) from the alternator.

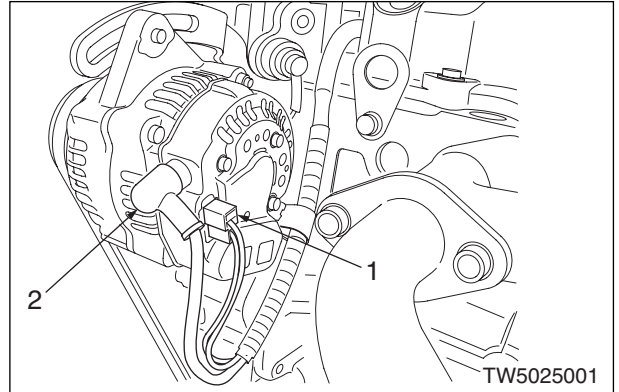

3. Fan belt

- 1) Slacken alternator fixing bolts (3).
- 2) Remove fan belt tightening bolt (4) and remove fan belt (5) from the pulley. [*1]

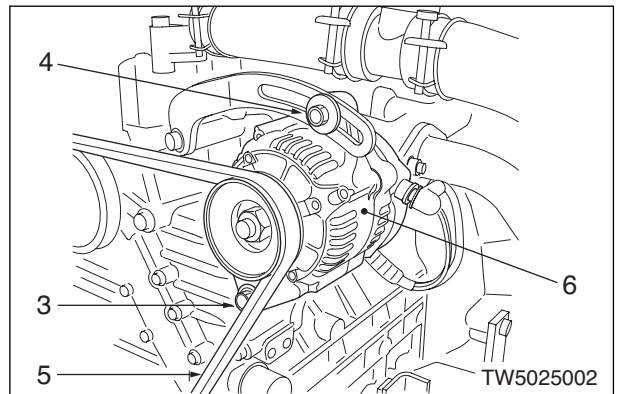

4. Alternator assembly

Remove fixing bolts (3) and remove alternator assembly (6).

1-2. Instration of alternator assembly

★ For installation, reverse the removal procedure.

[*1]

Adjust the fan belt with the adjust bolt so that the slack at the center between the fan and alternator puleys is 10 to 15 mm (0.39 to 0.59 in) with a push of about 10 kgf (98 N).

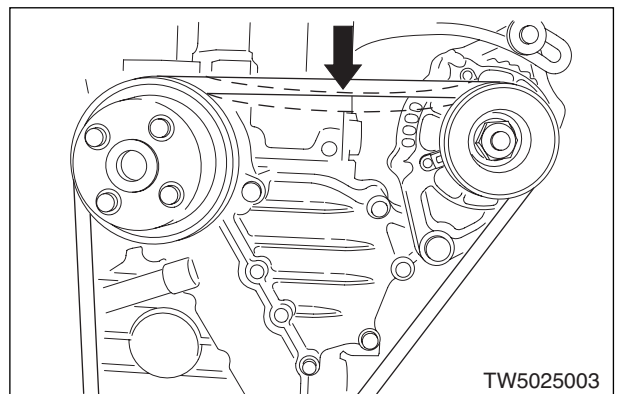

2. Removal and Installation of Starter Assembly

2-1. Removal of starter assembly

▲ Disconnect the negative (-) cable from the battery.

1. Engine hood

Open the left hand access cover of front frame.

2. Electric wiring of starter

Disconnect connector (1) and feed wire (2) from the starter.

3. Starter assembly

Remove two fixing bolts (3) and detach starter assembly (4).

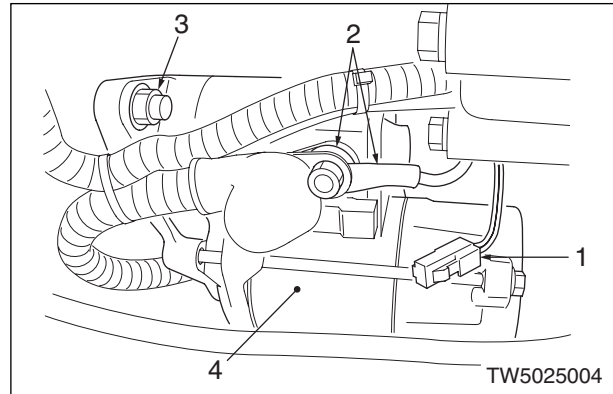

2-2. Installation of starter assembly

★ Use the removal procedure in the reverse sequence.

3. Removal and Installation of Radiator/Oil Cooler Assembly

3-1. Removal of radiator/oil cooler assembly

1. Engine hood

- 1) Open the engine hood.
- 2) Open the right hand side cover of front frame.
- 3) Remove the rear cover of front frame.

2. Draining of Coolant

Open the drain cock and drain coolant.

3. Air cleaner

- 1) Disconnect air cleaner hose (1).
- 2) Remove fixing bolts (2) and remove air cleaner assembly (3).

4. Oil cooler piping work

Disconnect inlet hose (6) and outlet hose(7) from the oil cooler.

⚠ Plug the open ends of the disconnected hoses to prevent engres of dust. Hold the open ends in a position higher than the hydraulic tank oil level.

5. Radiator piping work

Disconnect radiator inlet hose (4) and outlet hose (5) at the radiator.

6. Radiator/oil cooler assembly

- 1) Remove bolts (9) that secure the radiator-oil cooler assembly.
- 2) Remove radiator-oil cooler assembly (8).

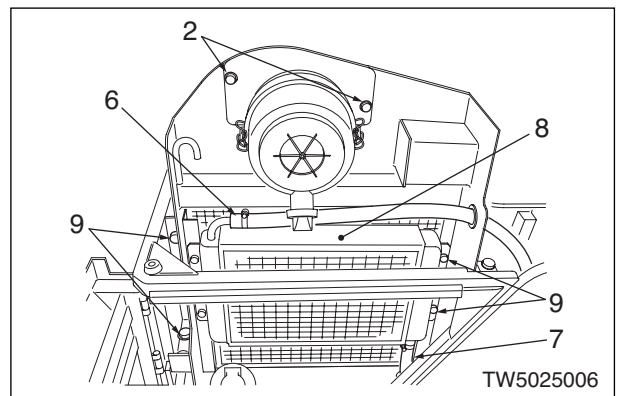
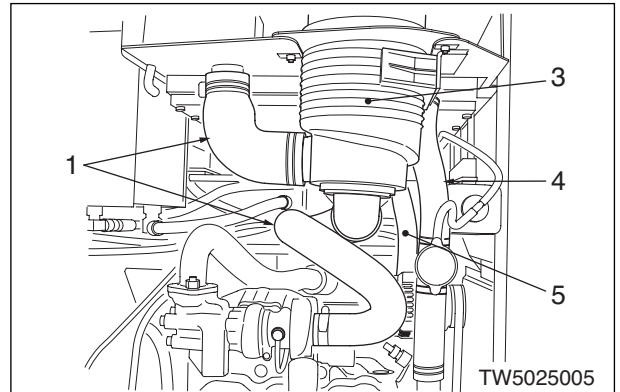

3-2. Installation of radiator/oil cooler assembly

- ★ Reverse the removal procedure.
- ★ Fill the radiator with a 35% long-life coolant to the specified level.
- ★ Add oil to the hydraulic tank to the specified level for compensation of a leak during removal.
- ★ Start the engine. Allow coolant to circulate through the engine and oil to pass through piping. Then recheck the coolant and oil levels.

4. Removal and Installation of Engine and Propulsion/Vibration/Steering/Charge Pump Assembly

4-1. Removal of engine and propulsion/vibrator/steering/charge pump assembly

⚠ Disconnect the battery negative (–) cable.

1. Removal of engine hood

- 1) Remove the damper inside the hood.
- 2) Lift the hood and remove the hinge and anti-fall arm. Take off the hood assembly.
- 3) Remove the front frame left side cover.

2. Electric wiring

- 1) Disconnect connector (1), harness (2) and propulsion pump solenoid valve wire connector (3). Put the harness at a location which does not hinder the work.
- 2) Disconnect wires at the engine that carry oil pressure sensor, thermo sensor, tachometer sensor and glow plugs.
- 3) Disconnect wires at the alternator and starter.

* See procedures under “Electric wiring of alternator”, page 5-101 and “Electric wiring of starter”, page 5-102.

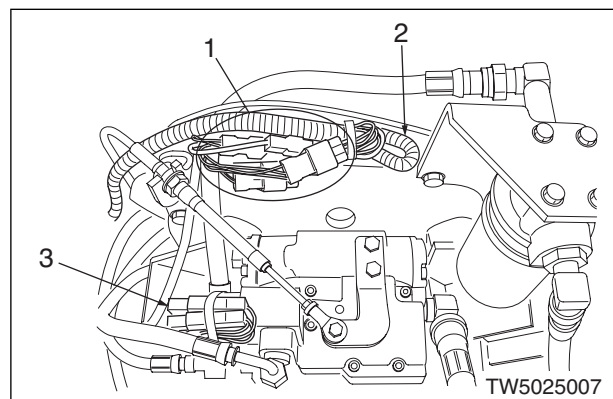

3. Air cleaner

Disconnect air cleaner intake hose (4).

4. Radiator hose

- 1) Drain the coolant from the radiator.
- 2) Remove upper hose (5) and lower hose (6).

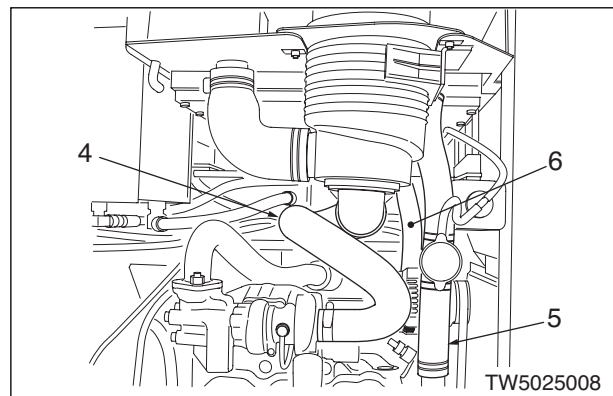

5. Throttle cable

Disconnect throttle cable (7) from the governor lever. Unscrew nut (8) and detach throttle cable at yoke (9).

6. Fuel hose

Disconnect fuel hoses (10) and (11).

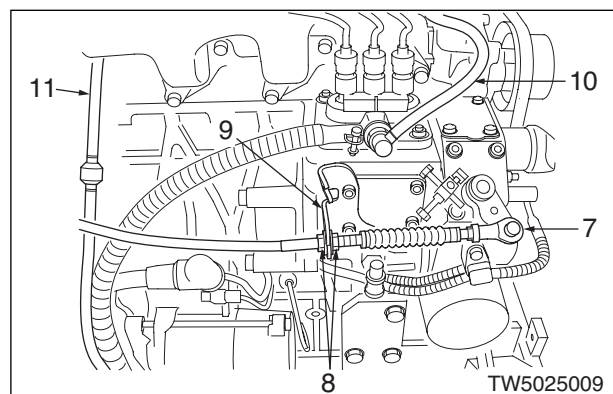

7. Forward-reverse cable (F-R cable)

Disconnect F-R cable (12) from control lever (13). Loosen nut (14) and remove from yoke (15).

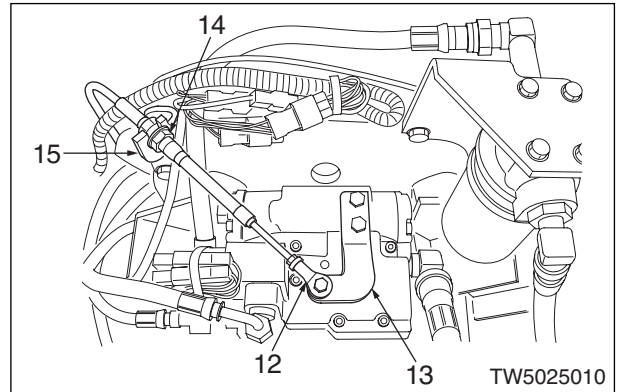

8. Propulsion pump hydraulic hose

Disconnect hydraulic hoses (16)–(23) at the propulsion pump.

★ Blank the open ends of hoses and elbows.

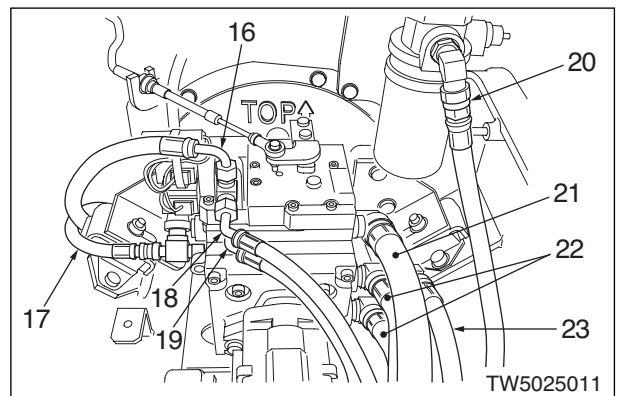

9. Hoses of vibration/steering/charge pump

Disconnect hydraulic hoses (27)–(28) at the vibrator/steering/charge pump.

★ Blank the open ends of hoses and elbows.

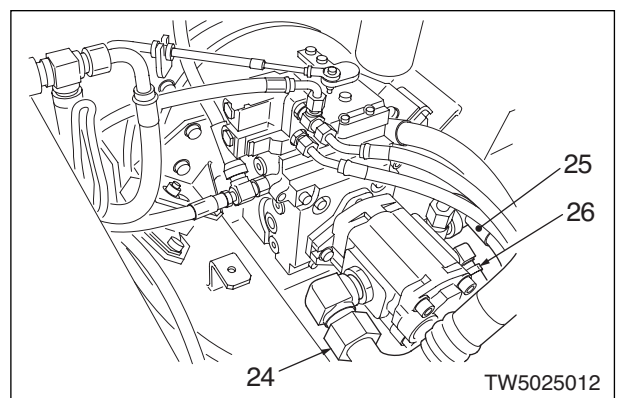

10. Vibrator pump hose (SW352, SW502)

Disconnect vibrator pump hoses (27), (28) on the engine side.

★ Blank the open ends of hoses and elbows.

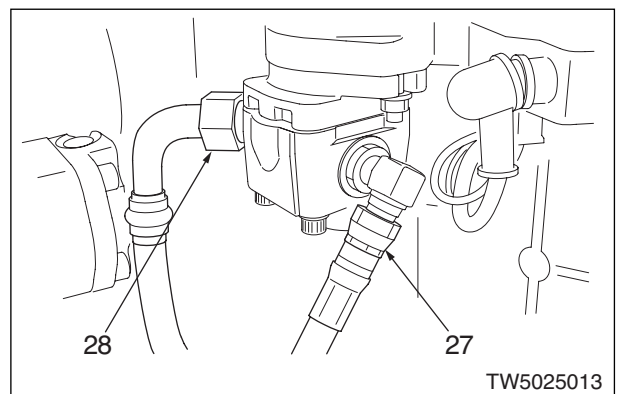

11. Engine oil drain hose and earth wire

- 1) Drain engine oil from the engine.
- 2) Disconnect drain hose (29) at the frame.
- 3) Disconnect earth wire (30) at the frame.

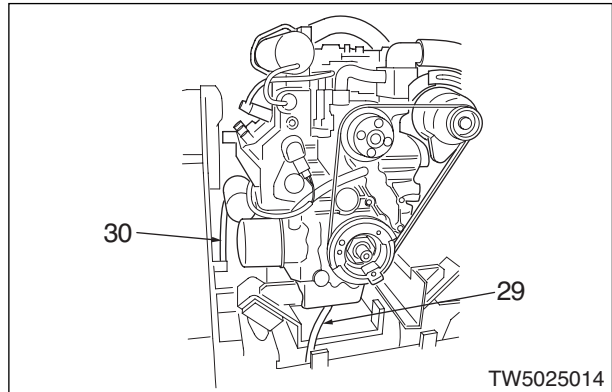

12. Assembly of engine and propulsion/vibration/steering/charge pump

- 1) On a hoist, temporarily lift and hold assembly (31) of engine/propulsion/vibrator/charge/steering pump.
- 2) Remove fixing nuts at front engine mounts (32) and rear mounts (33) on both right and left sides.
- 3) Lift the whole assembly (34) off the machine.

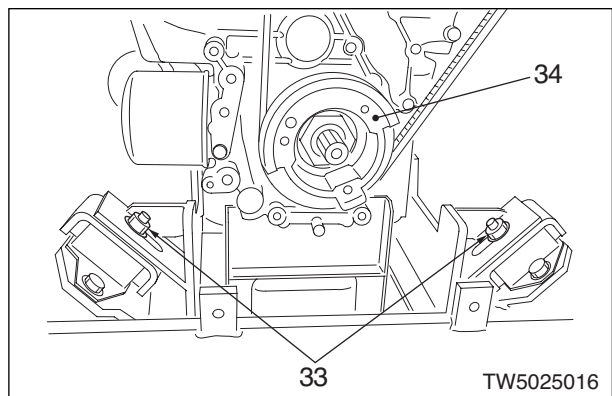
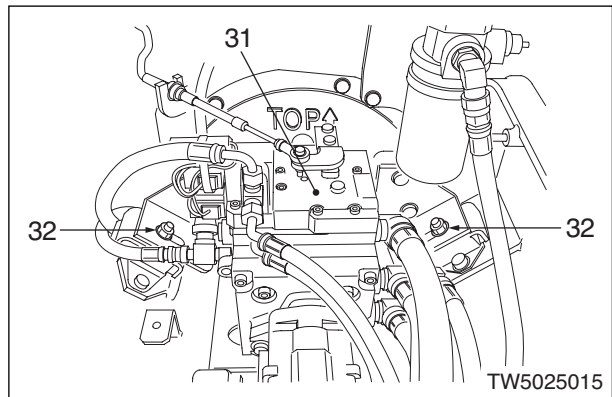

4-2. Installation of engine and propulsion/vibration/steering/charge pump assembly

★ For installation, reverse the removal sequence.

* Adjust the F-R lever linkage referring to “Adjustment of F-R lever linkage stroke”, page 3-109.

* Adjust the linkage referring to “Throttle linkage adjustment”, page 3-108.

★ Apply lithium grease to splined portions.

★ Bleed air from the fuel line.

★ Fill the radiator with a 35% long life coolant to the specified level.

★ Run the engine for coolant to circulate through the engine. Then recheck the coolant.

★ Add oil to the hydraulic tank to the specified level for compensation of a leak.

★ Run the engine to allow oil to circulate through the piping. Then recheck the oil level.

5. Removal and Installation of Coupling

5-1. Removal of coupling

1. Propulsion/vibrator/steering/charge pump assembly

Remove the assembly referring to “Removal of propulsion/vibrator/steering/charge pump assembly”.

2. Flywheel cover

- 1) With a jack, support the engine flywheel housing from below.
- 2) Remove rear engine mount fixing bolts (1) on right and left sides.
- 3) Remove eight flywheel securing bolts (2) and remove the flywheel cover together with propulsion/vibrator/steering/charge pump assembly (3).

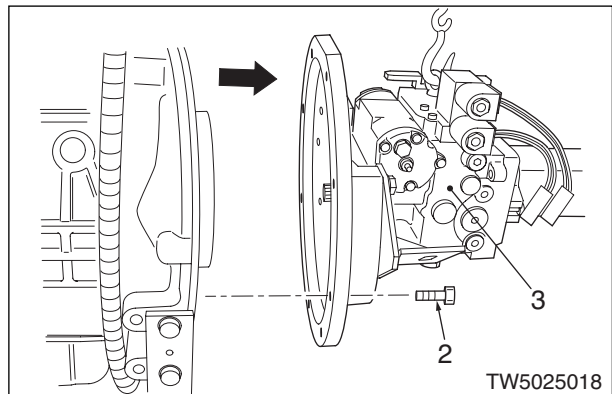
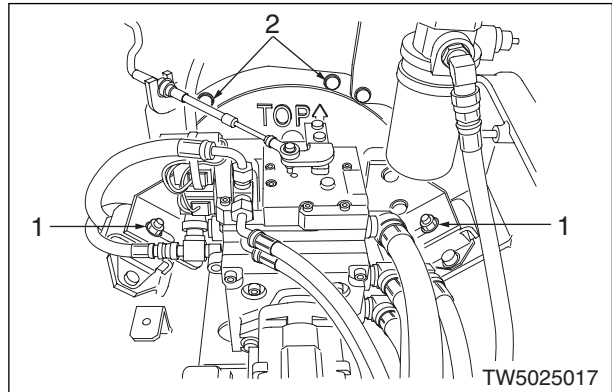

3. Coupling

Remove six retaining bolts (4) and remove coupling (5).

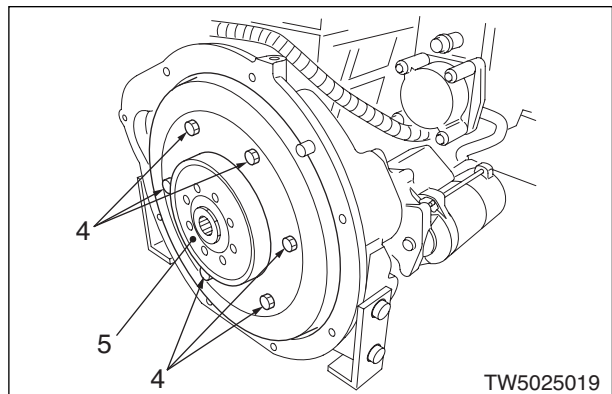

5-2. Installation of coupling

★ Installation is the reverse of removal procedure.

- Torque setting of bolts: 23 N·m (2.3 kgf·m)

6. Removal and Installation of Front Drum Assembly

6-1. Removal of front drum assembly

★ Remove the rear drum of SW352 and SW502 using the same procedure.

1. Scraper blade

Latch the scraper blades off the drum.

2. Propulsion motor piping

1) Disconnect hoses (1)–(5) at the propulsion motor.

★ Plug the open ends of hoses and openings of motors.

2) Remove hose clamps (6) and disconnect hoses from the machine.

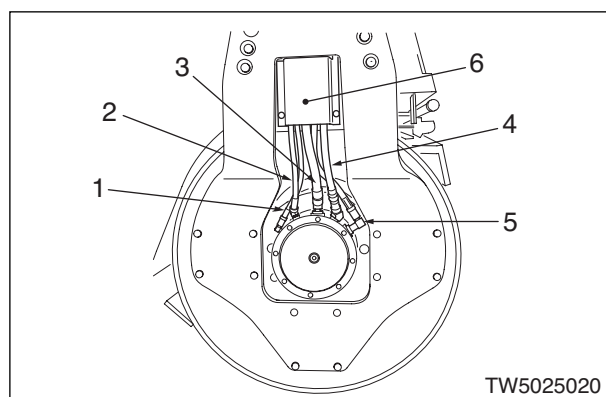

3. Vibrator motor piping

1) Disconnect hoses (7)–(9) at the vibrator motor.

★ Plug the open ends of hoses and openings of motors.

2) Remove hose clamps (10) and detach hoses from the machine.

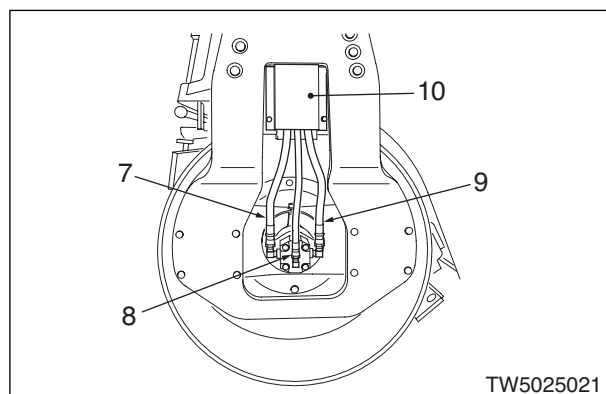

4. Front drum assembly

1) Using a hoist, lift and hold front frame (11).

2) Remove seven securing bolts (13) at side plate (12) and let the plate fall forward. [*2]

★ Release the negative brake by removing the plug at the center of the front propulsion motor first and then screwing the brake release bolt into the plug hole.

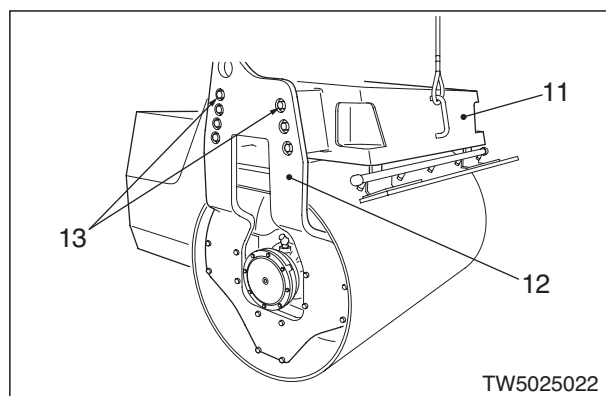

⚠ Take care when removing the plate. It will fall free the moment the whole bolts are taken off.

★ Remove the plate on the opposite side by using the same procedure.

Removal and Installation of Front Drum Assembly

- 3) On a hoist, lift and hold front frame (11). Place a wooden block under the front frame and disengage the hoist hook.

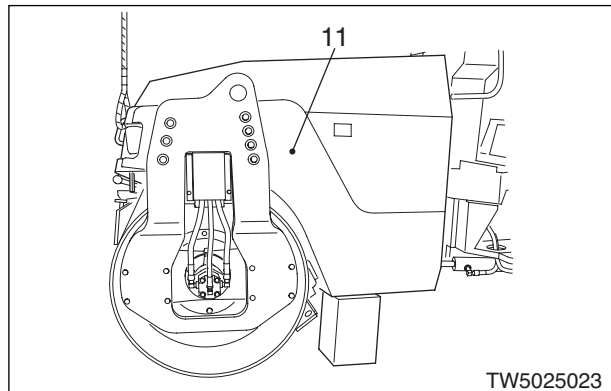

- 4) Lift the drum assembly (14) off the machine.
- 5) On a hoist, lift side plate (12), take off twelve retaining bolts (15), and separate plate (12) from shockmounts. [*1]

★ Use the same procedure to separate the side plate on the opposite side.

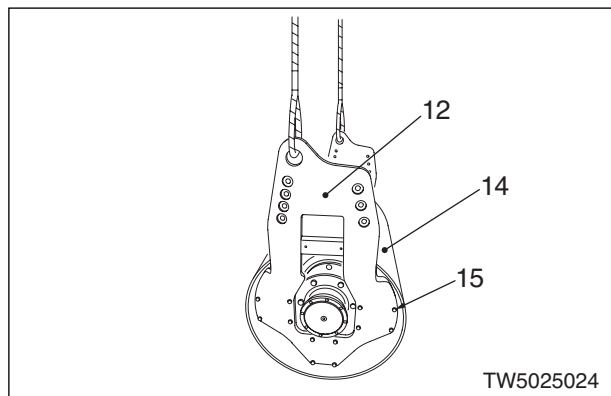

6-2. Instllation of front drum assembly

★ Install in the reverse order of removal.

[*1]

Tightening torque of bolts: 265 N·m (27 kgf·m)

[*2]

Tightening torque of nuts: 108 N·m (11 kgf·m)

★ Add oil to the hydraulic tank to the specified level for compensation of a leak during removal.

★ Start the engine. Allow oil to circulate through the piping then recheck the oil level.

7. Disassembly and Assembly of Front Drum Assembly

7-1. Disassembly of front drum assembly

Preparation

Remove front drum assembly referring to “Removal of front drum assembly”, page 5-109. Drain oil from the vibrator case.

1. Vibrator motor assembly

Remove two securing bolts (2) and remove vibrator motor assembly (1).

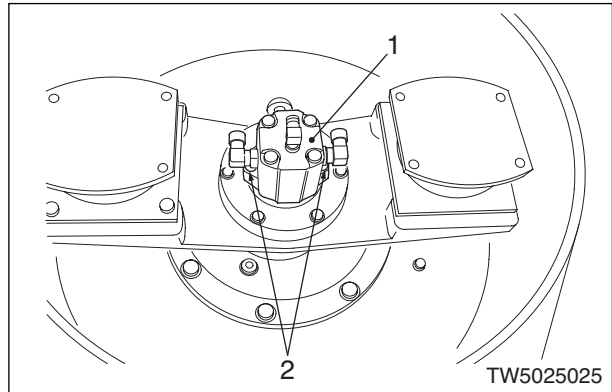

2. Sleeve

Remove sleeve (3).

3. Disc (vibrator motor side)

1) Using a hoist, stand drum assembly with the vibrator motor up.

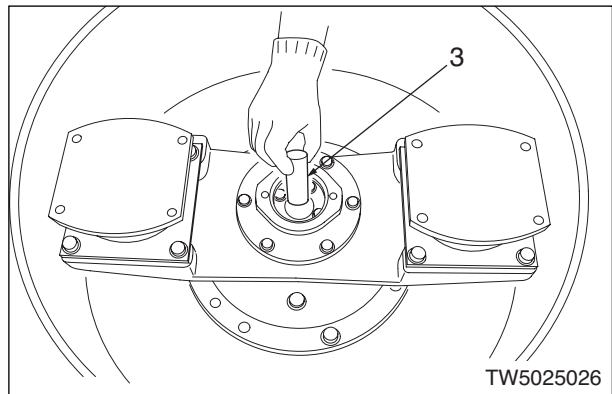

2) Remove six securing bolts (4) and remove cover (5) from the disc.

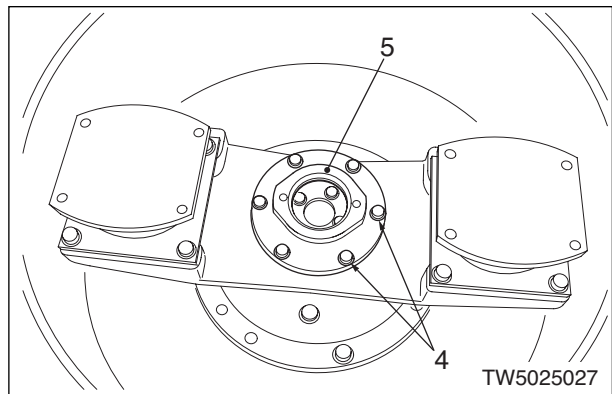

3) Remove four retaining bolts (6) and remove cover (7).

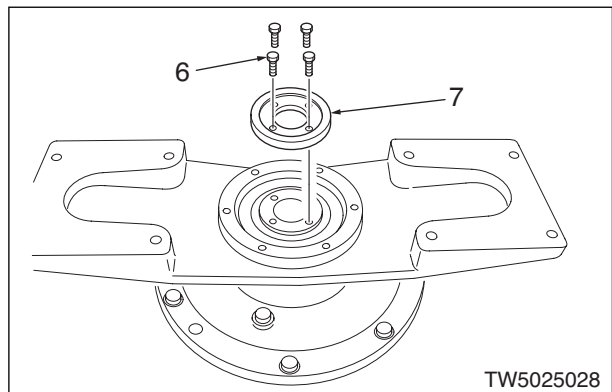

- 4) With a puller, pull off disk (8) from axle shaft (9).

★ The bearing inner race is removed together with the disc.

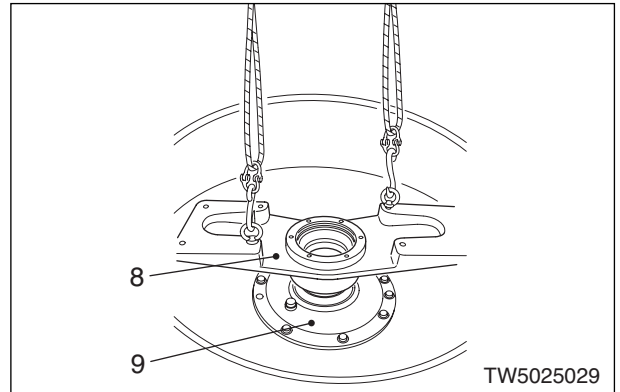

4. Axle shaft

- 1) Remove eight fixing bolts from axle shaft (9).
- 2) Allow axle shaft (9) to float by screwing pull bolts into the axle shaft.
- 3) Replace the pull bolts with lifting bolts. On a hoist, lift off axle shaft (9).

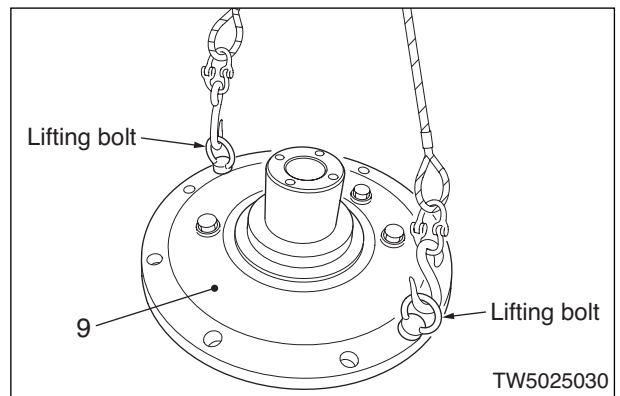

5. Disc (propulsion motor side)

- 1) On a hoist, lift the drum and stand with the propulsion motor up.
* See “Disassembly of front drum assembly”, page 5-112.
- 2) Remove elbos (10)–(14).
- 3) Remove six securing bolts (15). Using lifting bolts, remove disc (16) from the propulsion motor.

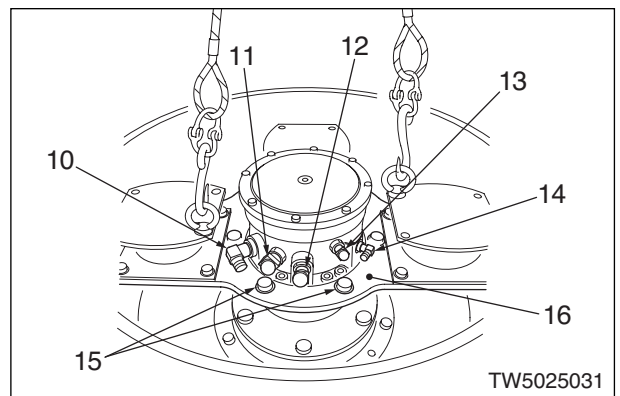

6. Propulsion motor assembly

Remove six retaining bolts (17). Using lifting bolts, lift off propulsion motor assembly (18).

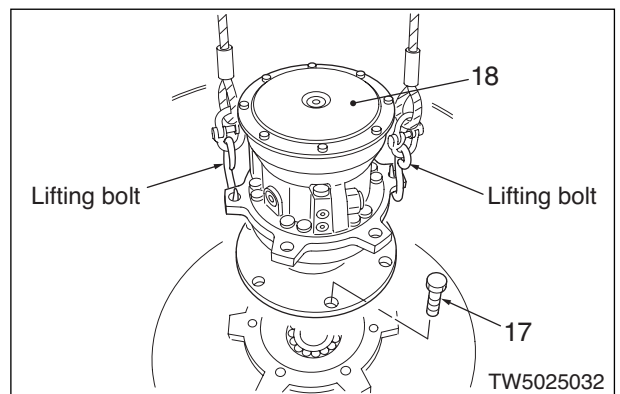

7. Holder & vibrator shaft

- 1) Remove eight fastening bolts (19).
- 2) Screw pull bolts into the holes of holder (20) and separate it from the drum.
- 3) Using lifting bolts and shackles, lift off holder (20).

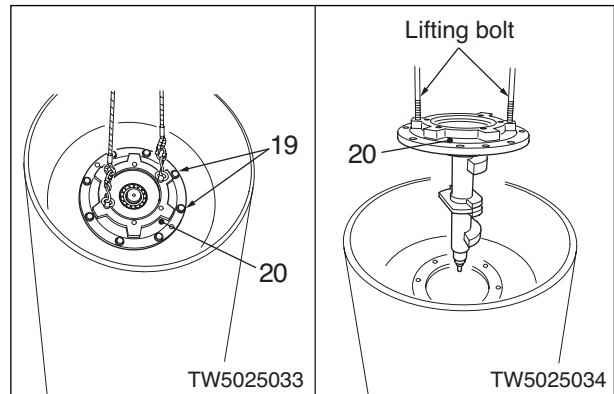

- 4) While holding vibrator shaft (21), remove lock ring (22) and pull off vibrator shaft (21) from holder (20).

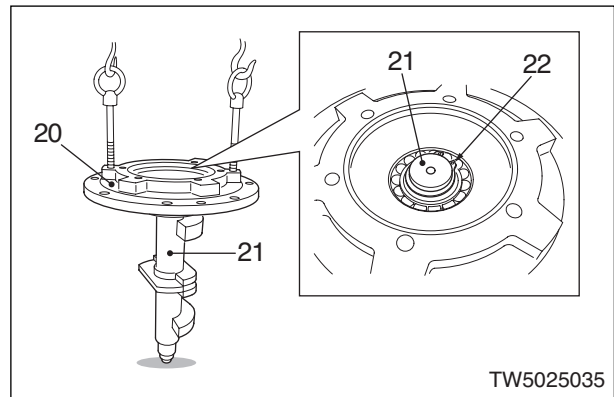

- 5) Remove lock ring (24) and take off bearing (23) from holder (20).

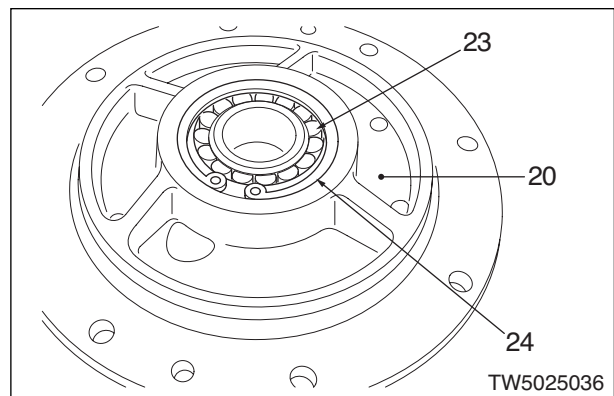

7-2. Assembly of front drum assembly

★ Thoroughly clean the parts and remove burrs etc.

1. Holder & vibrator shaft

- 1) On a hoist, stand the drum on the floor with propulsion motor up.

* See “Disassembly of front drum assembly”, page 5-112.

- 2) Install bearing (23) to holder (20).
- 3) Install lock ring (24) in position.

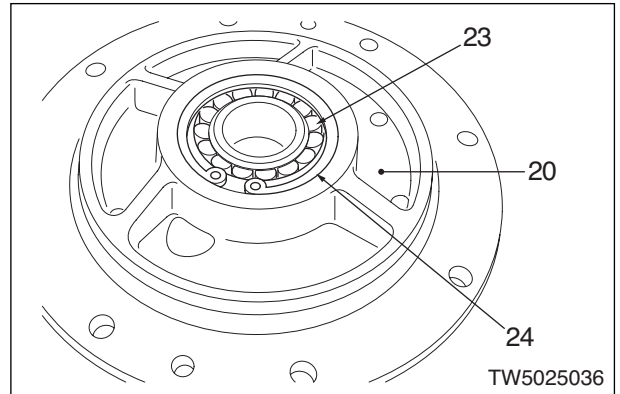

- 4) With vibrator shaft (21) standing, assemble holder (20) onto the shaft and install lock ring (22).

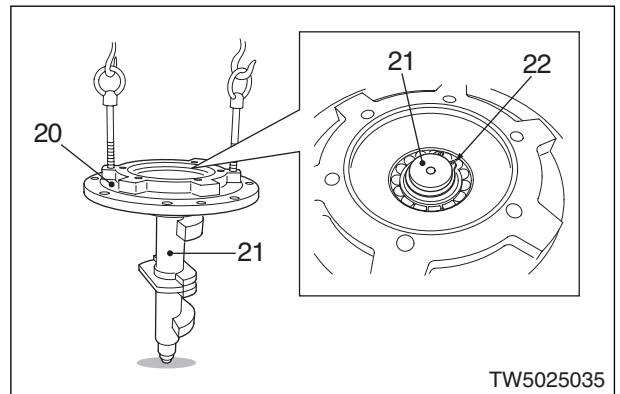

- 5) Using lifting bolts, mount holder (20) to the drum.

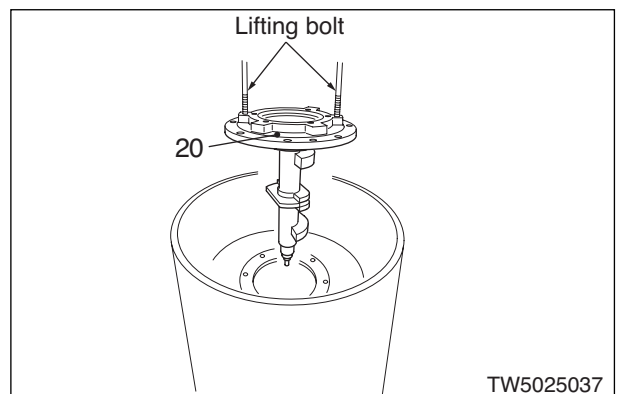

2. Propulsion motor assembly

Using lifting bolts, lift the propulsion motor assembly (18) and install it to the drum. Tighten eight fixing bolts (17).

- Tightening torque: 343 N·m (35 kgf·m)

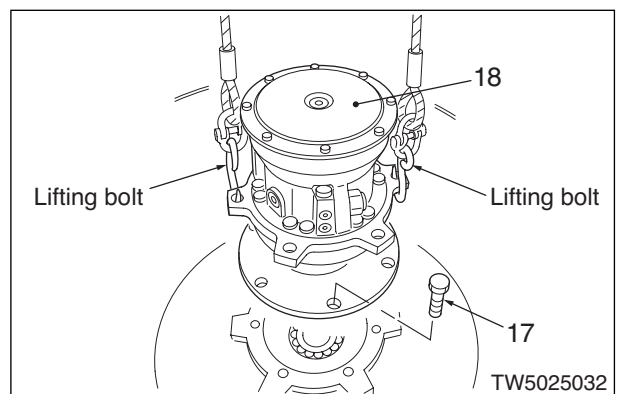

3. Disc

- 1) Using lifting bolts, install disc (16) to propulsion motor assembly. Tighten six securing bolts (15).
 - Tightening torque: 343 N·m (35 kgf·m)
- 2) Install elbos (10)–(14).

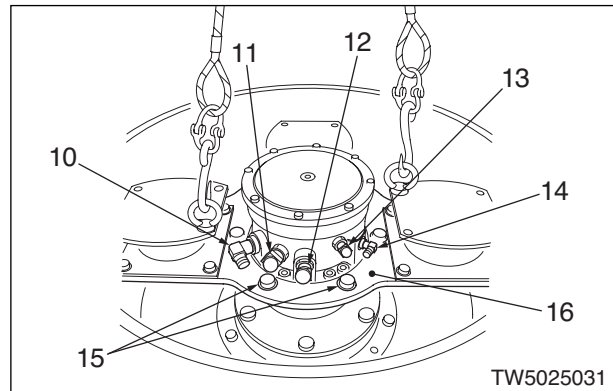

4. Vibrator shaft end float

- ★ Make sure that the vibrator shaft has an end float of about 2.5 mm (0.1 in)

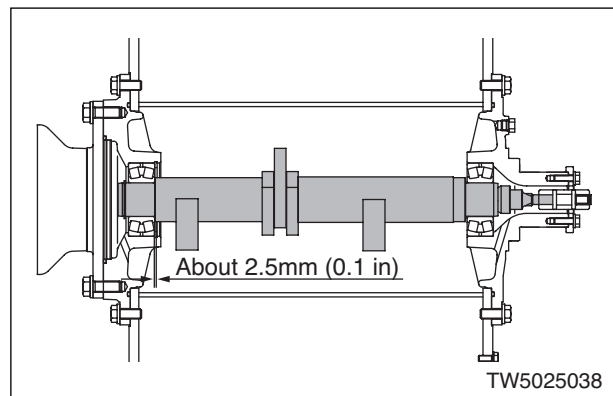

5. Axle shaft

- 1) Using lifting bolts, assemble axle shaft (9) onto the vibrator shaft. Tighten the eight fixing bolts.
 - Tightening torque: 265 N·m (27 kgf·m)

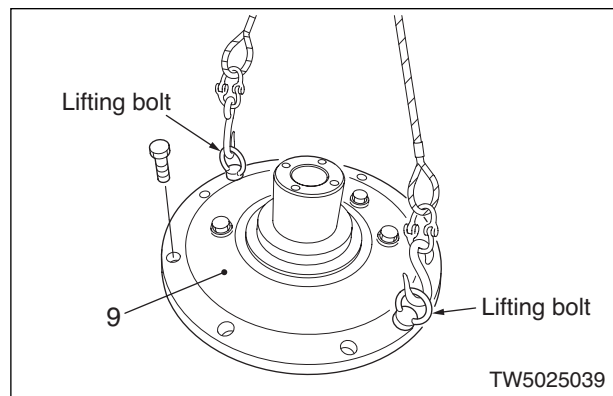

- 2) Assemble bearing (12) onto axle shaft (9).

- ★ Apply lithium grease to the bearing.

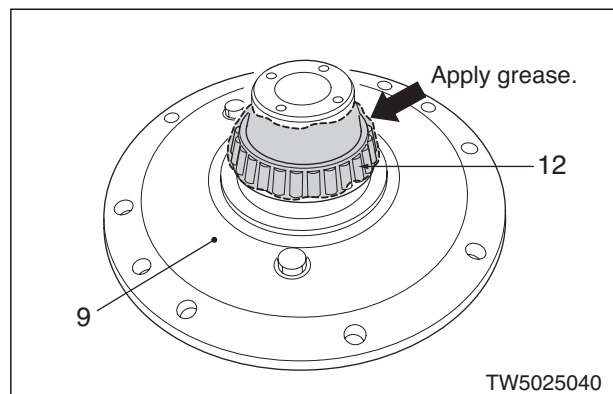

6. Disc (vibrator motor side)

- 1) Press the bearing outer race into disc (8).
- 2) Using a hoist, position disc (8) on axle shaft (9).
- 3) Apply grease to the bearing and press it into axle shaft (9).

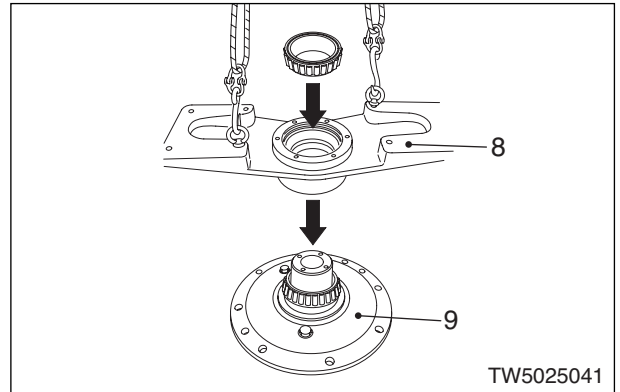

- 4) When installing cover (7), make a preload adjustment by using shims as follows:

4.1) After installing the bearing, fit the removed shims. Tighten four securing bolts of cover (7) to 12.7 N·m (1.3 kgf·m). Then rotate disc (8) one turn clockwise and one turn counterclockwise. Retighten the bolts to the above-mentioned torque.

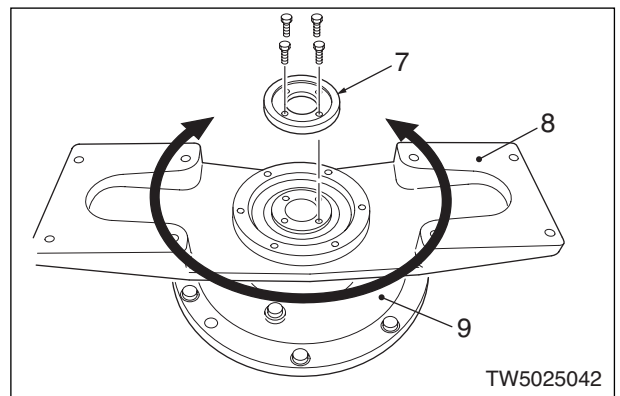

4.2) After that measure the clearance between cover (7) and axle shaft (9) with a thickness gauge. Fit shims with their thickness equivalent to the clearance. Retighten the four bolts to 59 N·m (6.0 kgf·m).

4.3) Then spin disc (8) two turns clockwise and counterclockwise each, hook a spring balance to a shockmount fastening bolt and measure the force when the disc starts spinning (disc drag).

- Disc drag: 64 N·m (6.5±0.3 kgf·m)
(SW352, TW352)
- 45 N·m (4.5±0.3 kgf·m)
(SW502, TW502)

If the drag is lower than specified, increase shim thickness.

If the drag is higher than specified, decrease shim thickness.

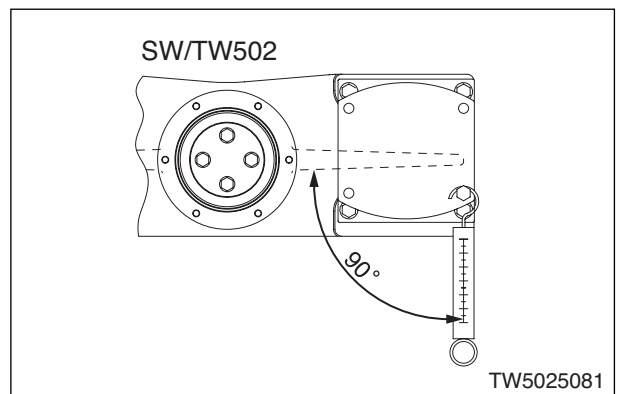
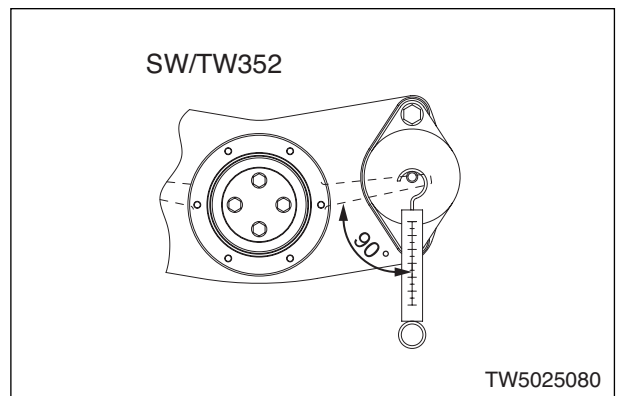

- 5) Fit cover (5) and tighten six fixing bolts (4).
• Tightening torque: 108 N·m (11 kgf·m)

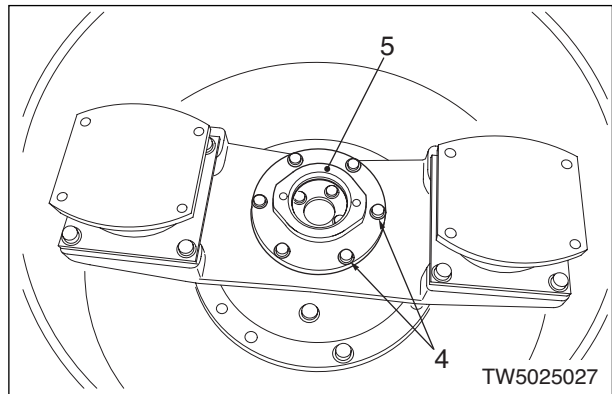

7. Sleeve

- Fit sleeve (3) to the vibrator shaft

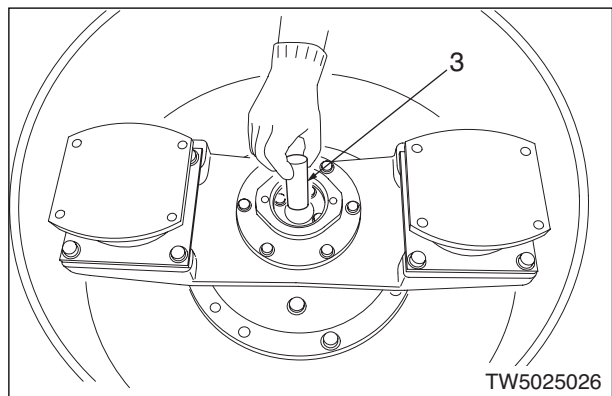

8. Vibrator motor assembly

- Install propulsor motor assembly (1) to sleeve (3). Tighten two fixing bolts (2).

- Tightening torque: 49 N·m (5 kgf·m)

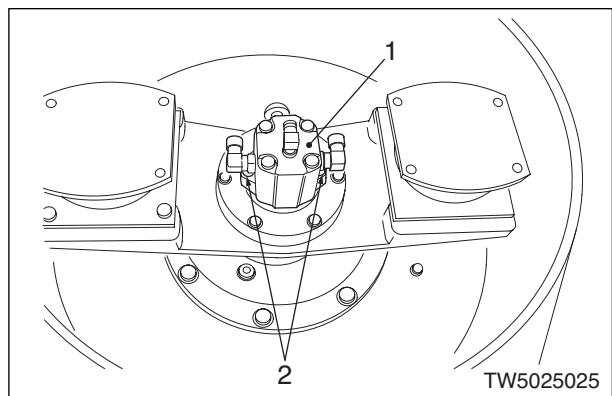

8. Removal and Installation of Center Pin Assembly

8-1. Removal of center pin assembly

⚠ Disconnect battery negative (-) cable.

1. Hydraulic hose

- 1) Remove the floor board by the operator's seat.
- 2) Remove seven hoses (1)–(3).
★Blank the open ends of hoses and adapters.

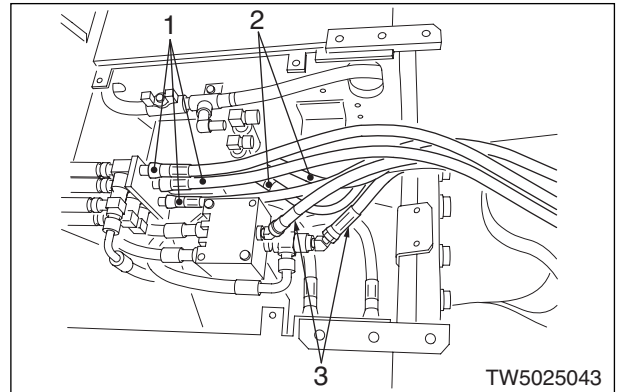

2. Electric wiring

Detach connectors (4) and place the hoses close to the front frame so that they may not interfere with the work.

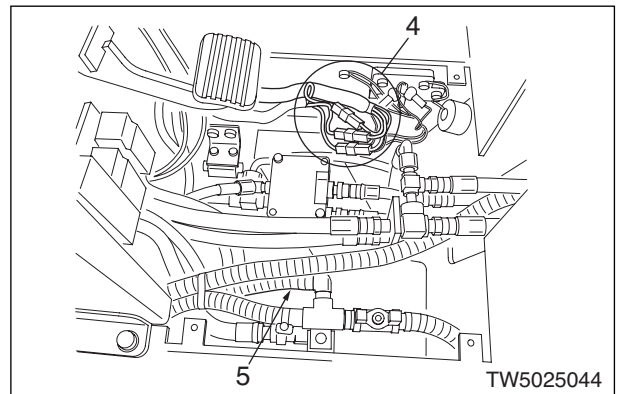

3. Sprinkler

Disconnect hoses (5) and put them close to the front frame.

4. Throttle cable & F-R cable

- 1) Take off Orbitrol cover.
- 2) Remove throttle cable (6) and position it close to the front frame.
- 3) Remove F-R cable (7) and position it close to the front frame.

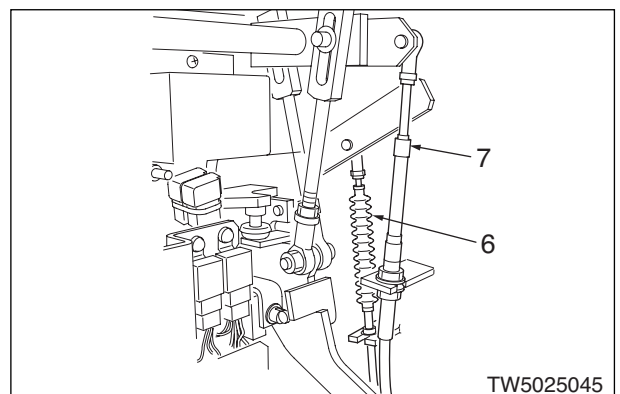

Removal and Installation of Center Pin Assembly

5. Steering cylinder rod

Remove the lock plate bolt, pull off pin (8) and disconnect the rod (9) from the front frame.

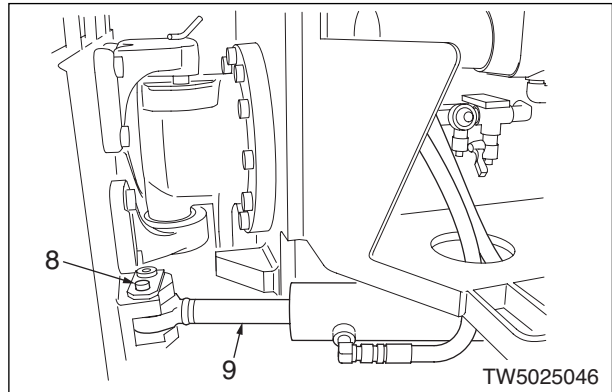

6. Front frame & drum assembly

- 1) Using a jack, support the rear frame from below.
- 2) Release the front propulsion motor negative brake.
- 3) On a hoist, lift front frame (10) at the position close to the center pin.

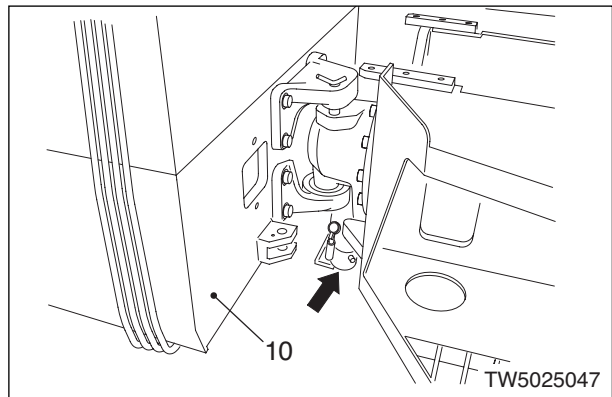

- 4) Remove eight center pin bracket fixing bolts (11). [*1]
- 5) Roll out the drum off front frame (10), and lower the frame on a stand.

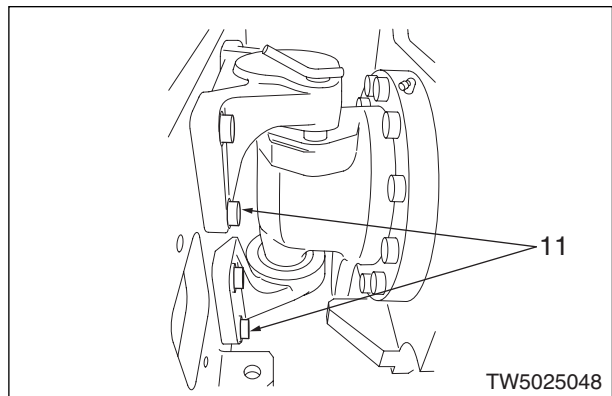

7. Center pin assembly

- 1) Temporarily lift and hold center pin assembly (12).
- 2) Remove twelve fixing bolts (13) and remove center pin assembly (12) on a hoist. [*2]

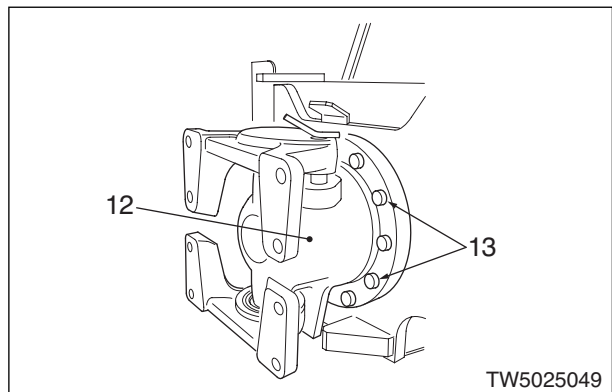

8-2. Installation of center pin assembly

★ Reverse the removal procedure.

[*1] [*2]

Torque setting of bolts: 265 N·m (27 kgf·m)

★ Add oil to the tank to the specified level for compensation of a leak.

★ Start and run the engine to circulate oil through the piping. Recheck the oil level.

9. Removal and Installation of Rear Propulsion Motor Assembly and Wheels (TW352, TW502)

9-1. Removal of rear propulsion motor assembly and wheels

★ For a fork lift to operate, secure enough spaces on the left and right sides of the machine.

1. Scraper blades

Latch the scraper blades off the drum.

2. Jacking up of machine

Using a hydraulic jack, lift rear frame (1) by about 50 mm (2.0 in) above the floor.

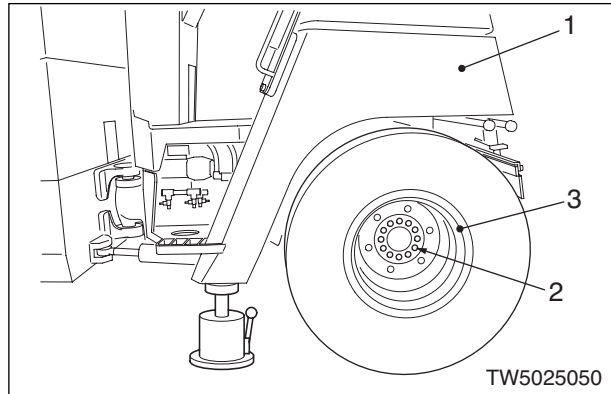

3. Rear wheels (left)

1) Remove twelve inner bolts (2) from wheel (3). [*3]

2) Using a fork lift, pull off the left-hand two-tire assembly to the left.

★ Withdraw the right-hand two-tire assembly in the same manner.

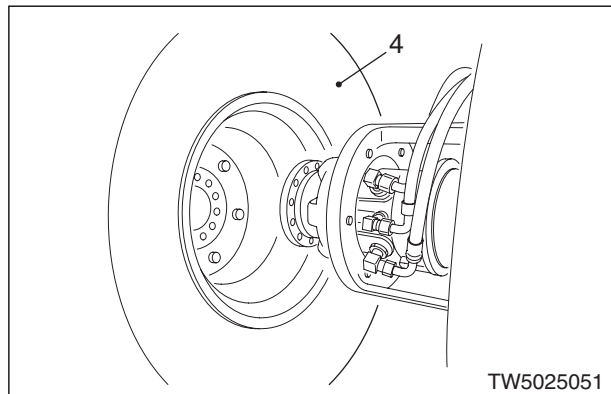

4. Hydraulic hose of propulsion motor

Disconnect hoses (5)–(8).

★ Blank the open ends of hoses and elbows.

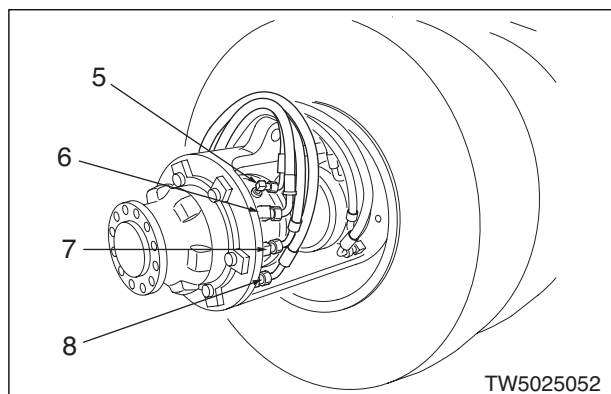

5. Rear motor assembly

1) Remove six propulsion motor securing bolts (9).

2) Move the propulsion motor inward and pull off rearward. [*2]

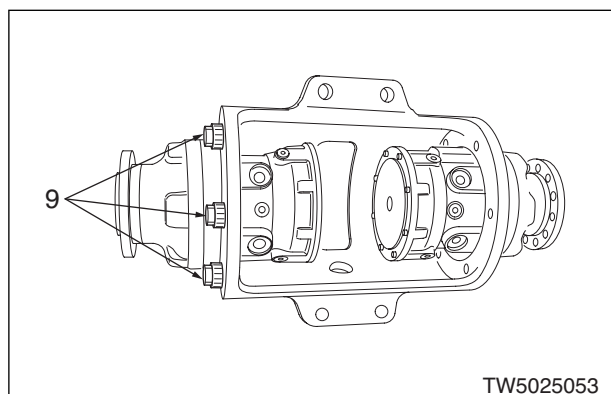

6. Removal and installation of wheels

- 1) Remove six hub nuts (10) from wheel (3).
[*1]
- 2) On a hoist, lift off wheel (3).

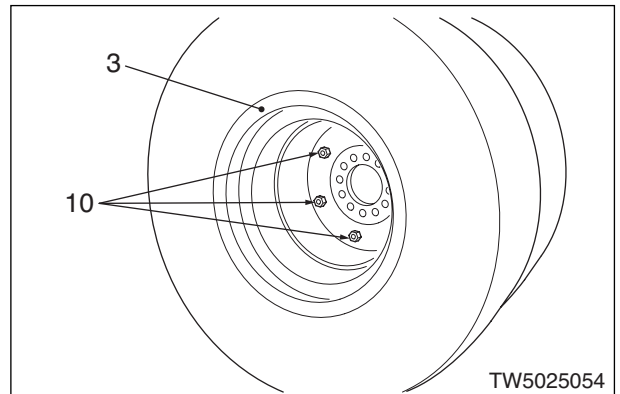

- 3) Turn the wheel assembly upside down and remove six hub nuts (10).

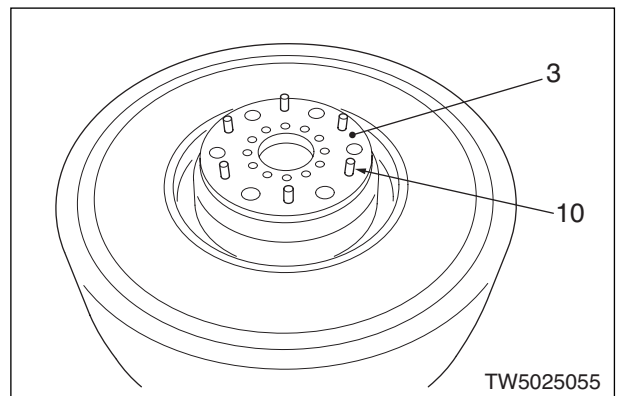

9-2. Installation of rear propulsion motor assembly and wheels

★ Install by reversing the removal sequence.

[*1]

Torque setting of bolts: 186 N·m (19 kgf·m)

[*2]

Torque setting of bolts: 265 N·m (27 kgf·m)

[*3]

Torque setting of bolts: 167 N·m (17 kgf·m)

★ Add hydraulic oil to the tank to the specified level for compensation of a leak.

★ Start and run the engine to circulate oil through the piping. Recheck the oil level.

10. Removal and Installation of Propulsion/Vibration/Steering/Charge Pump Assembly (SW352, SW502)

10-1. Removal of propulsion/vibration/steering/charge pump assembly

★ Remove the assembly referring to steps 7 to 9 in “Removal of engine and propulsion/vibration/steering/charge pump assembly”, page 5-104.

- 1) Temporarily lift and hold the propulsion/vibration/steering/charge pump assembly and remove two bolts (2) that fasten the clutch housing to propulsion pump (1). [*1]
- 2) Lift off the propulsion/vibration/steering/charge pump assembly.
- 3) Remove two bolts (4) that fix vibration/steering pump assembly (3) to propulsion pump (1) and remove the assembly. [*2]

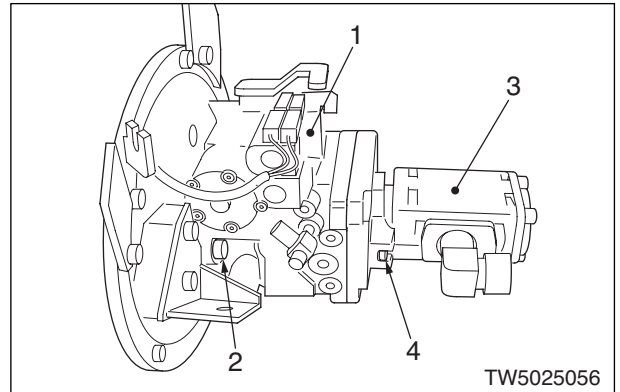

10-2. Installation of propulsion/vibration/steering/charge pump assembly

★ Install by reversing the removal procedure.

[*1]

Tightening torque setting of propulsion pump securing bolts: 108 N·m (11.0 kgf·m)

[*2]

Tightening torque setting of vibrator/steering/charge pump securing bolts: 49 N·m (5.0 kgf·m)

* Adjust linkage referring to “Adjustment of F-R lever linkage stroke”, page 3-109.

★ Apply lithium grease to the splined portion of the pump.

★ Add oil to the tank to the specified level for compensation of a leak.

★ Start and run the engine to allow oil to circulate through the piping. Recheck the oil level.

11. Removal and Installation of Vibrator Pump Assembly (SW352, SW502)

11-1. Removal of vibrator pump assembly

1. Hydraulic oil

Drain half an amount of hydraulic oil from the pump.

2. Hydraulic hose

Disconnect vibrator hoses (1) and (2) at the engine.

★ Blank the open ends of hoses and elbows.

3. Vibrator pump assembly

Remove two fixing nuts (3) and remove the

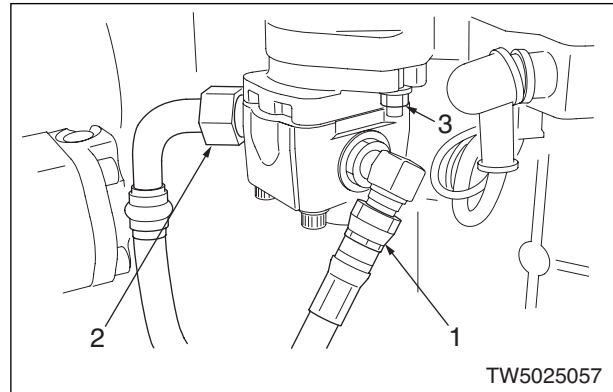

11-2. Installation of vibrator pump assembly

★ Install in the reverse order of removal. [*1]

[*1]

Tightening torque of vibrator pump fixing bolts:
49 N·m (5 kgf·m)

★ Add oil to the tank to the specified level for compensation of a leak.

★ Start and operate the engine to allow oil to circulate through the piping. Recheck the oil level.

12. Removal and Installation of Vibrator Motor Assembly

12-1. Removal of vibrator motor assembly

1. Hydraulic hose

Disconnect hoses (2)–(4).

★ Blank the open ends of hoses and elbows.

2. Vibrator motor ass'y

Remove two fixing bolts and remove vibrator motor assembly (1). [*1]

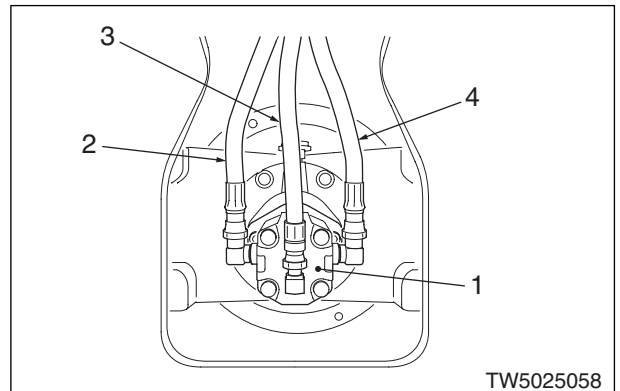

12-2. Installation of vibrator motor assembly

★ Reverse the removal sequence.

[*1]

Tightening torque of vibrator pump fixing bolts:
49 N·m (5 kgf·m)

★ Add oil to the tank to the specified level for compensation of a leak.

★ Start and run the engine to circulate oil through the piping. Recheck the oil level.

13. Disassembly and Assembly of Propulsion Motor Negative Brake

13-1. Disassembly of propulsion motor negative brake

1. Brake cover

Slacken eight socket head cap screws (2) fastening brake cover (1).

* Loosen the screws evenly, since brake spring (3) attempts to lift brake cover (1).

	DCM0280	DCM0560
Screw size	M6X20L	M8X25L
Width across flats	5 mm	6 mm

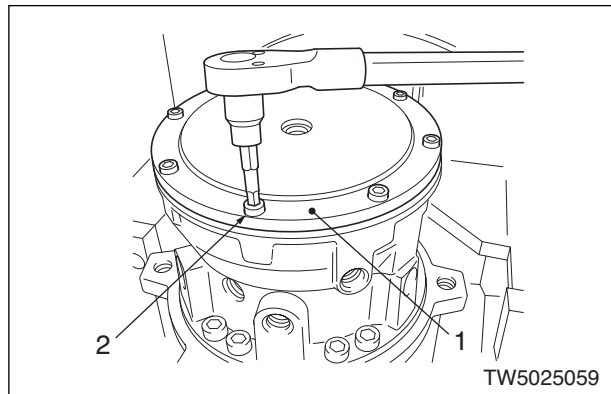

⚠ If the screws are not slackend evenly, the last screw is likely to break.

2. Brake spring

When brake cover (1) is removed, brake spring (3) will appear. Remove the spring.

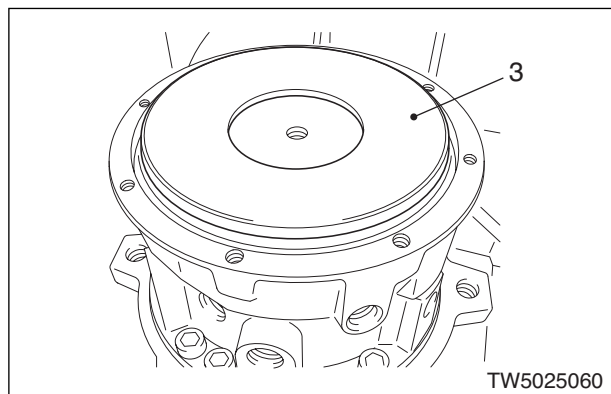

3. Preparation for brake piston removal

After removing O-ring and socket head plugs with O-ring fitted from the forced brake release port, position brake cover (1) on the brake housing. Keep the brake release pilot port (4) open to vent residual pressure.

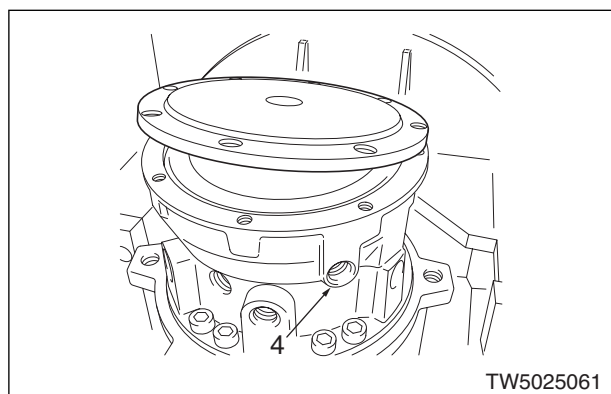

4. Brake piston

Brake piston will be lifted with the forced brake release screw (5) (socket head cap screw) screwed into the brake release port.

Screw and washer for forced brake releasing

	DCM0280	DCM0560
Screw (Pitch)	M10X25L (1.5 mm)	M12X30L (1.75 mm)
Washer	For M10 screw	For M12 screw
Outer diameter	19~23 mm	22~27 mm
Thickness	2.5~3.5 mm	2.5~3.5 mm

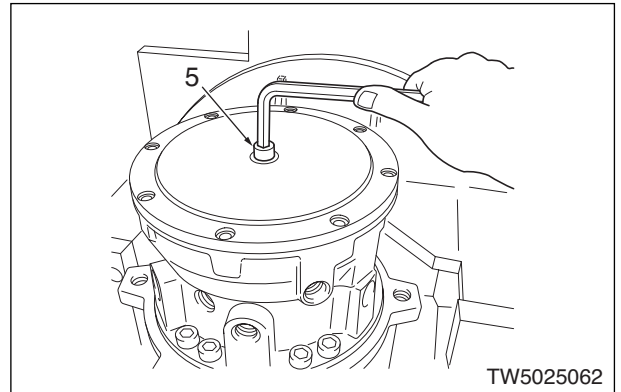

TW5025062

⚠ Use the washer without fail to protect the O-ring.

5. Brake piston removal

After fully screwing in the brake release screw, loosen it once and place block (6) between the brake housing and brake cover to lift the brake piston further. Increase the thickness of the block until the brake piston is separated.

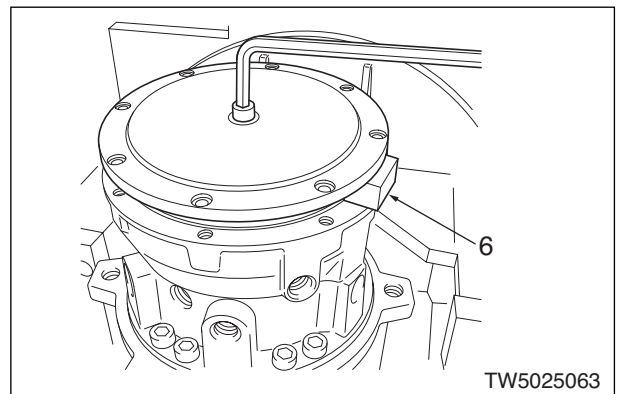

TW5025063

6. Brake disc

Take off the brake shim, separate discs (7) and friction discs (8). Use a wire with a bent end to make the work easy. Remove four to five pieces of separate discs (7) and friction discs (8), then the brake shaft will be pulled off.

Item	Quantity
Brake shim	A / R
Separate disc	15
Friction disc	14

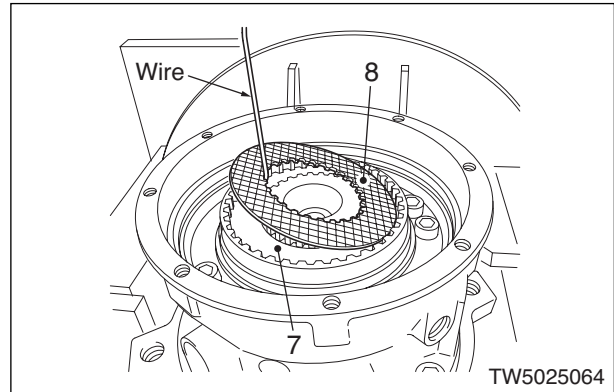

⚠ Use caution not to lose the steel ball and brake shaft spring.

13-2. Assembly of propulsion motor negative brake

1. Brake disc

Assemble the brake shaft into the brake housing. Install separate discs (7) and friction discs (8) alternately paying attention to the quantity and sequence of the discs to assemble.

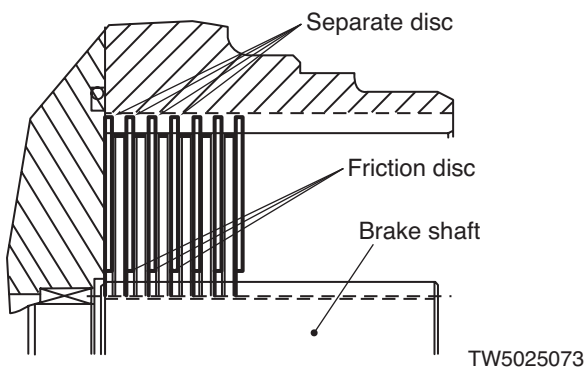
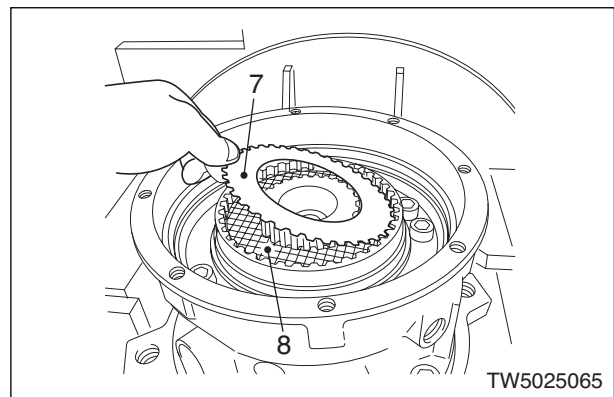

⚠ Push the brake shaft fully home. If the brake discs are assembled with the brake shaft not driven in fully, the friction discs may slip off the splined portion.

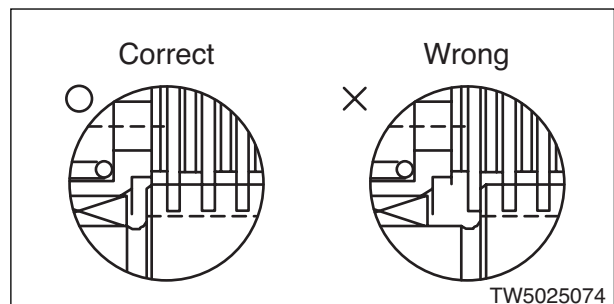

2. Brake shim

After assembling separate discs (7) and friction discs (8), proceed to the installation of brake shims (9). Principally, original shims (9) that have been removed should be used, but if the stroke of brake piston (“Inspection after replacement”, page 5-134) is not to specification, increase or decrease shim (9) thickness.

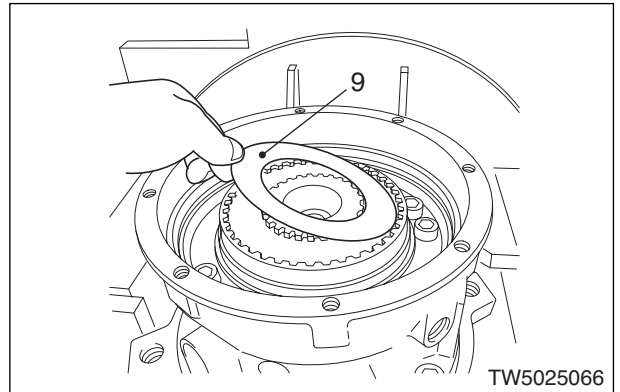

Brake shim package

	DCM0280	DCM0560
Drawing No.	1745162-S	1745280-S
Thickness	0.8 mmX1 piece	0.8 mmX1 piece
	0.4 mmX1 piece	0.4 mmX1 piece
	0.2 mmX1 piece	0.2 mmX1 piece
	0.1 mmX1 piece	0.1 mmX1 piece

★ Upon request of spare parts, above set is supplied as package.

3. Steel ball

Assemble brake shaft spring (10) and steel ball (11) into the cam motor. If the brake is assembled into the cam motor with the cam motor positioned horizontally (brake is fitted from the side), apply a slightly high viscous grease to steel ball (11) to prevent falling free.

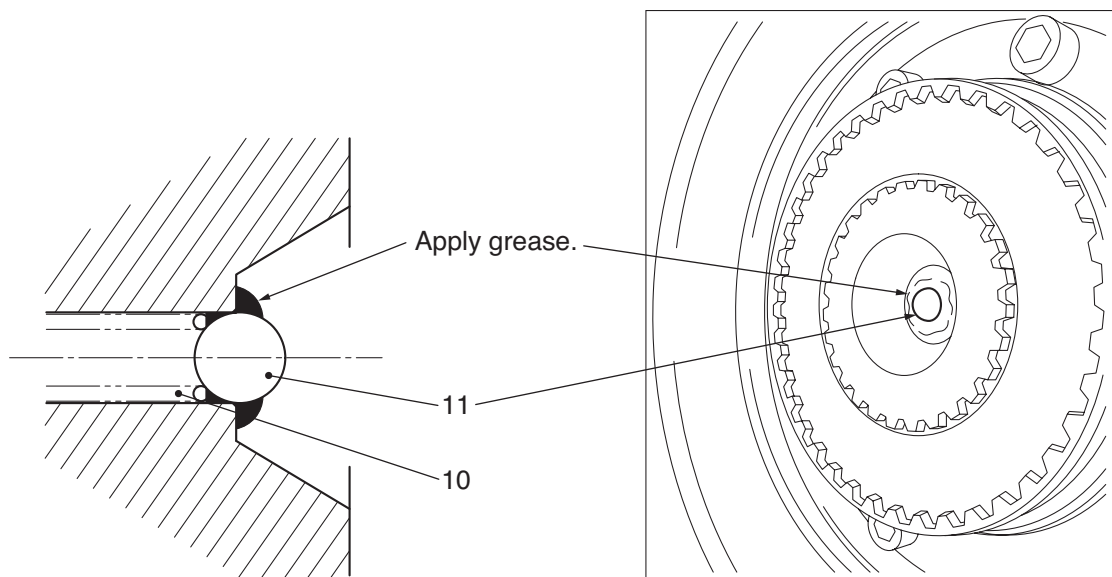

TW5025075

⚠ If the brake is fitted with the cam motor placed horizontally, ensure that the brake shaft has been driven fully home. The distance between the brake housing spline end and brake shaft end should fall within the range as specified below:

	DCM0280	DCM0560
Distance L	1.2~2.8 mm	1.3~2.9 mm

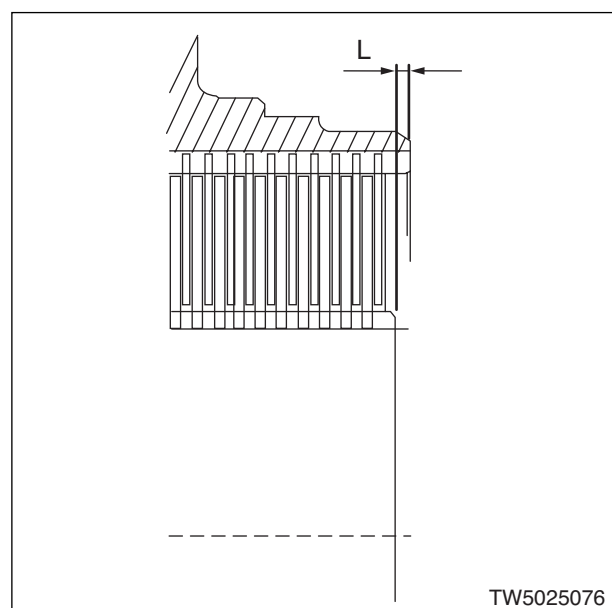

TW5025076

4. Brake piston

Assemble the small O-ring and big O-ring to brake piston (12). Assemble brake piston (12) into the brake housing. Drive the brake piston fully home by tapping it with a soft-faced hammer.

- ⚠ **Apply a coat of mineral oil jelly to the O-rings to prevent scratching.**

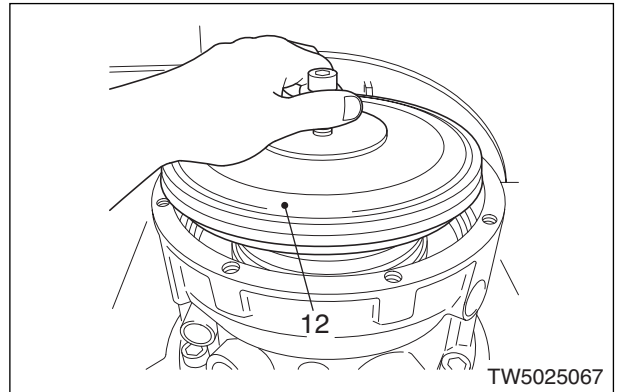

5. Brake spring

Position brake spring (3) on brake piston (12). On brake spring (3), place brake cover (1) in which O-ring is set.

- ⚠ **Apply a coat of mineral oil jelly to the O-rings to prevent scratching.**

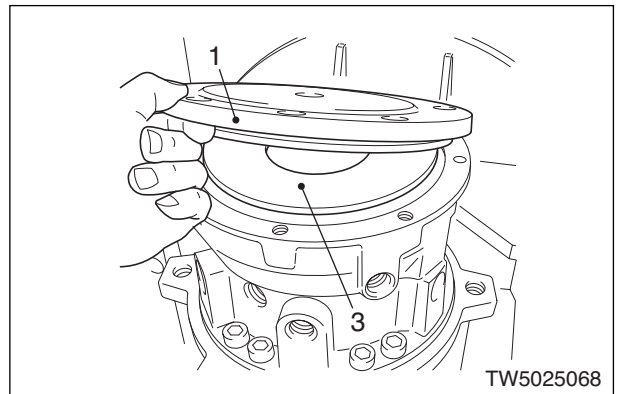

6. Brake cover

Tighten socket head screws (2) that fix brake cover (1).

★ Tighten the eight screws evenly.

- ⚠ **Failure to tighten the screws evenly can break the first bolt.**

Torque setting of socket head screws

	DCM0280	DCM0560
Screw size	M6X20L	M8X25L
Tightening torque	14~17 N·m (1.4~1.7 kgf·m)	33~41 N·m (3.4~4.2 kgf·m)

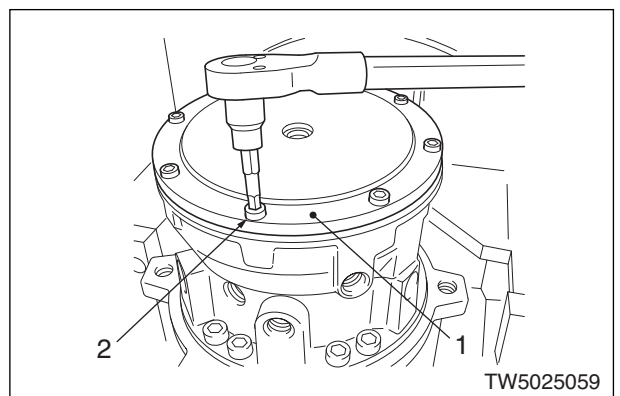

Inspection after replacement (Measurement of brake piston stroke)

- The brake stroke mentioned below is the value for new brake discs, which differs from the stroke specified under “Replacement standard” for used discs, page 5-136.

1. Forced brake release screw

Drive the brake release socket head screw into the brake release port. Do not screw in fully.

	DCM0280	DCM0560
Brake release screw size (pitch)	M10X25L (1.5 mm)	M12X30L (1.75 mm)

Using a depth gauge, measure distance L1 between the brake cover surface and the screw head with the brake release pilot port open to the atmosphere (brake is applied).

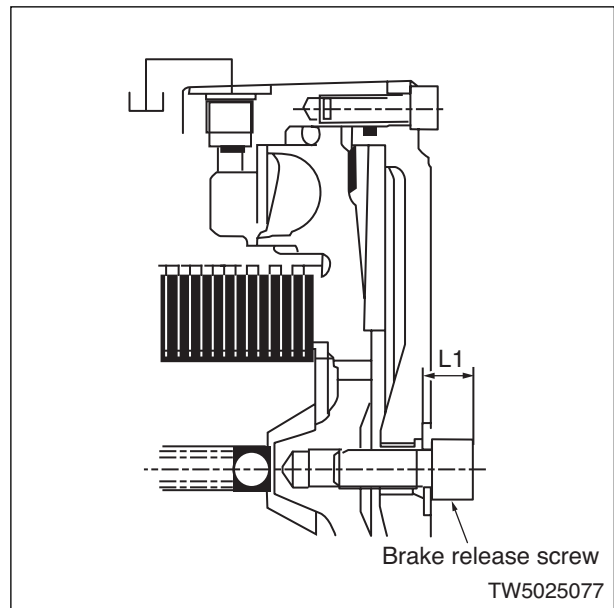

2. Checking for brake stroke

Using a depth gauge, measure dimension L2 from the brake cover surface to the brake release screw head with the brake release pressure applied to the pilot port (brake is released).

- Brake piston stroke: L2-L1

★ The brake piston stroke with new brake should be within the range shown below. If it falls outside this range, increase or decrease the shim thickness.

	DCM0280 / 0560
Brake piston stroke with new brake discs	1.6~2.3 mm

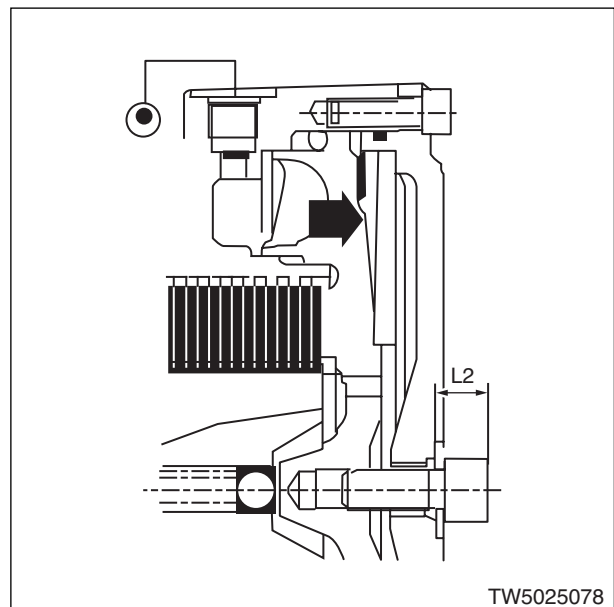

3. Installation of plug

Screw socket head plug (13) with the O-ring into the forced brake release port.

Torque setting of forced brake release port plug

	DCM0280	DCM0560
Plug size	G1/4	G3/8
Width across flats	6 mm (0.24 in)	8 mm (0.32 in)
Tightening torque	27~31 N·m (2.8~3.2 kgf·m)	46~52 N·m (4.7~5.3 kgf·m)

During the short run-in period after installing the cam motor brake discs, the whole thickness of the discs tends to decrease to some extent. For this reason, the stroke of a new brake should be set to somewhat longer value.

Replacement standard

- If unusual signs are noticeable as stated below, renew the whole friction discs and separate discs.
 - 1) The braking force is lower than the tractive force of the propulsion motor. (When the propulsion motor is powered, the motor starts running, although the brake stays applied.)
 - 2) Any of the friction discs or separate discs are seized.
 - 3) The brake piston stroke exceeds 3.5 mm (0.14 in). (Refer to page 5-136.)

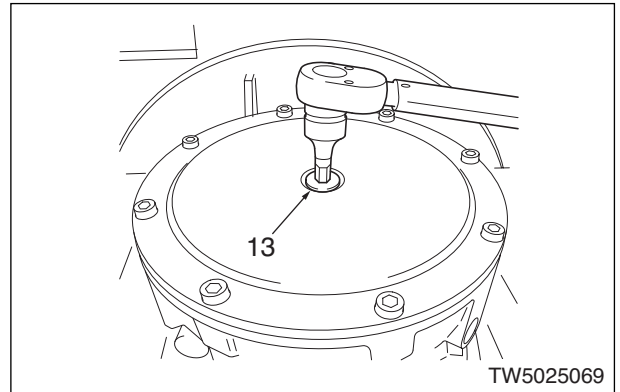

Measurement of brake piston stroke (replacement standard)

1. Plug removal

Remove the socket head plug (14) with O-ring from the brake release port.

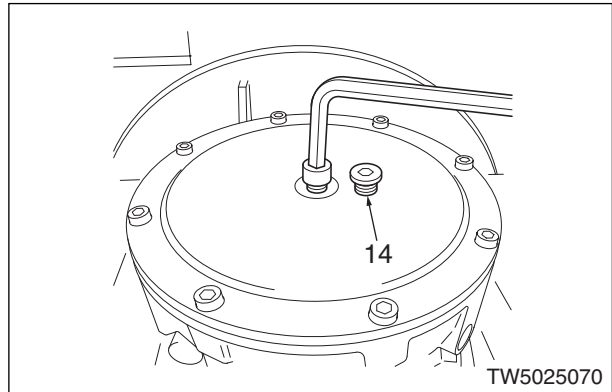

2. Brake release bolt

Screw the brake release socket head screw into the brake release port. Do not screw in fully.

	DCM0280	DCM0560
Brake release screw size (pitch)	M10X25L (1.5 mm)	M12X30L (1.75 mm)

Using a depth gauge, measure distance L1 between the brake cover and the screw head with the brake release pilot port open to the atmosphere (brake is applied).

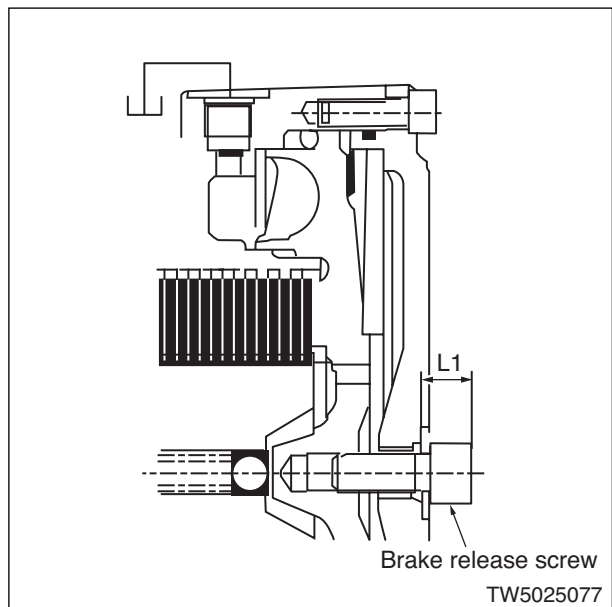

3. Checking for brake stroke

Using a depth gauge, measure distance L2 from the brake cover surface to the screw head with the brake release pressure applied to the pilot port (brake is released).

- Brake piston stroke: L2-L1

★ If the brake piston stroke with used brake discs exceeds the standard value shown below, renew the whole friction and separate discs.

	DCM0280 / 0560
Brake stroke in replacement standard	3.5 mm (0.14 in)

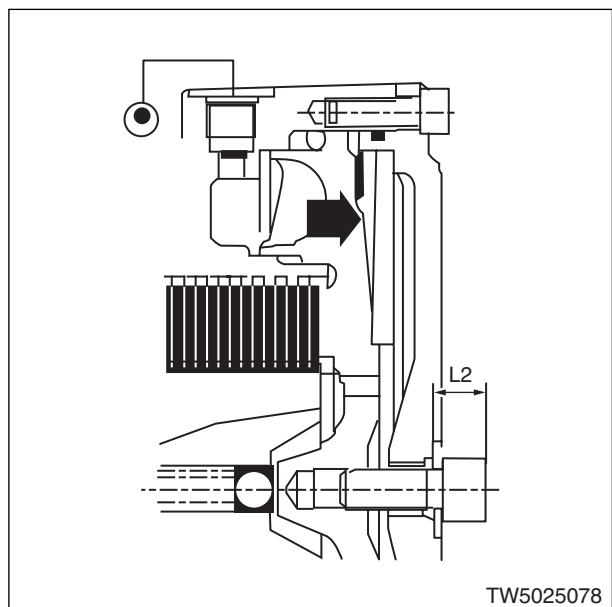

Spare parts list

It is recommended to renew O-rings when replacing friction discs and separate discs.

No	Item	Qt'y	Drawing No. (Daikin No./Standard nominal size)	
			DCM0280	DCM0560
D12	Friction disc	14	SP1988	SP2090
D13	Separate disc	15	1733585	1733704
D14	Brake shim set	1	1745162-S	1745280-S
D51	O-ring	1	KG1A105 / 1A G105	KG1A130 / 1A G130
D52	O-ring	1	KG1A155 / 1A G155	KG1A195 / 1A G195
D53	O-ring	1	KA1B164 / AS568-164	KA1B170 / AS568-170
Items for reference				
D02	(Brake cover)	(1)	(1723016-01)	(1714934-01)
D03	(Brake piston)	(1)	(1723017-01)	(1714935-01)
D04	(Brake shaft)	(1)	(1733583)	(1733702)
D11	(Brake spring)	(1)	(1733584)	(1733703)
D21	(Brake shaft spring)	(1)	(1745653)	(1745653)
D22	(Steel ball $\phi 12.7$)	(1)	(HKW04)	(HKW04)
D42	(Socket head screw)	(8)	(AAM0602001 / M6X20, 12.9T)	(AAM0802501 / M8X25, 12.9T)
D63	(Socket head plug)	(1)	(HP11020-2)	(HP11020-3)
D64	(O-ring)	(1)	(KP1B011 / 1B-P11)	(KP1B014 / 1B-P14)

★ Parts given in parentheses are for reference only and not necessary to replace.

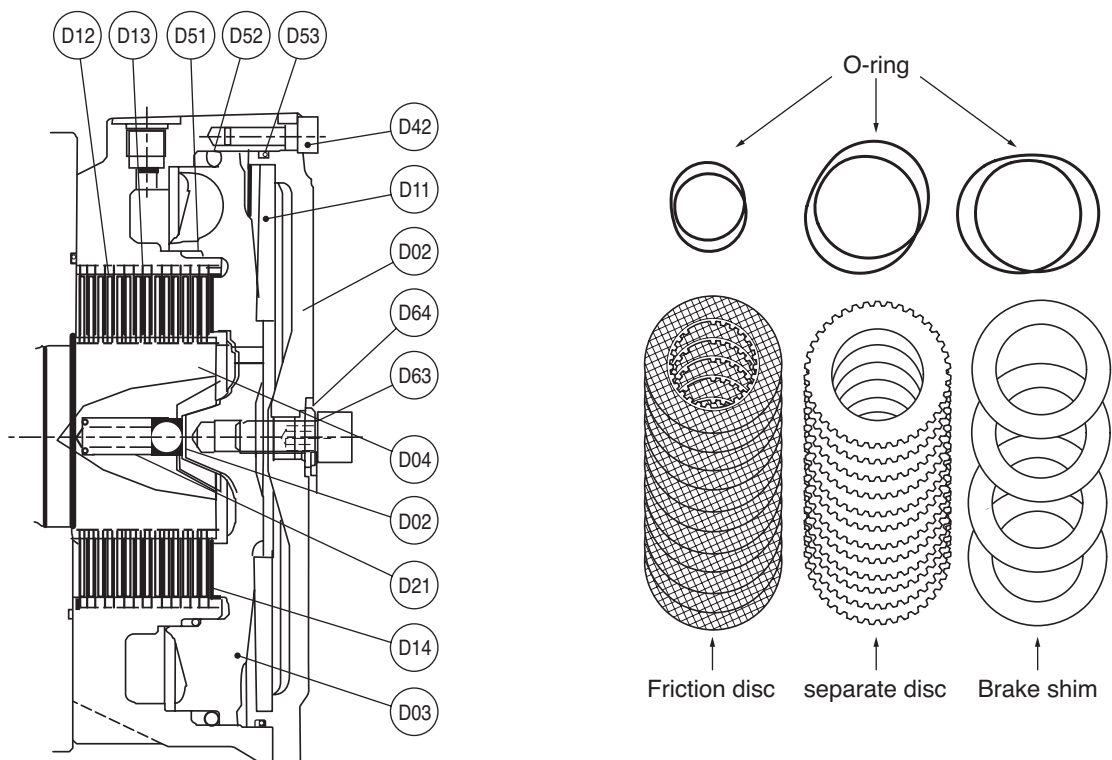

14. Removal and Installation of Steering Cylinder Assembly

14-1. Removal of steering cylinder assembly

* Engage the steering lock bar securely for safe work in the articulated area of the machine.

1. Cylinder rod

Pull pin (1) and remove cylinder rod (2) from bracket (3).

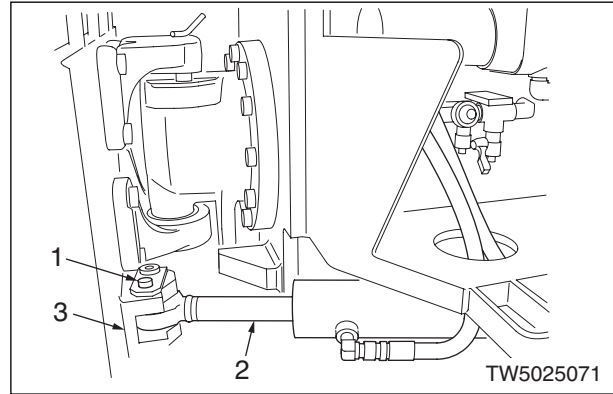

2. Hydraulic hoses

1) Run the engine and fully retract the piston rod of the steering cylinder.

2) Disconnect hoses (4) and (5) from the cylinder.

★ Blank the open ends of the elbows on the cylinder.

3. Hydraulic hoses

1) Support the cylinder assembly from below.

2) Pull off the pin and remove the cylinder assembly.

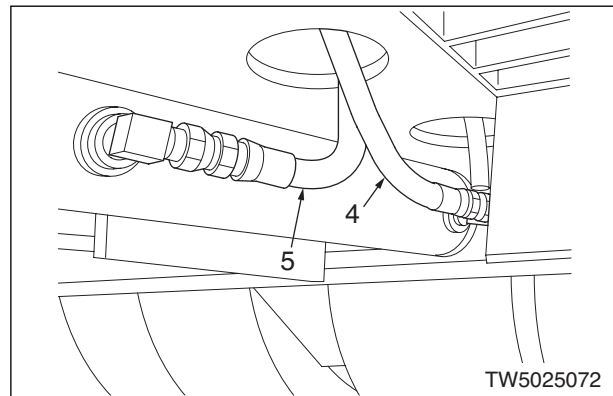

14-2. Installation of steering cylinder assembly

- ★ For installation, reverse the removal procedure.
- ★ Fit spacer between the rod and bracket on top and bottom locations.
- ★ Add oil to the specified level.
- ★ Start the engine. Allow oil to circulate through the piping. Recheck the oil level.

15. Disassembly and Assembly of Steering Cylinder Assembly

15-1. Disassembly of steering cylinder assembly

Preparation

Remove the steering cylinder assembly using the procedure in “Removal of steering cylinder assembly”, page 138.

1. Piston-piston rod assembly

- 1) Loosen end cap (2) and pull off the assembly from cylinder (3).

★ Hold the cylinder in a vice.

- 2) Pull off piston-piston rod assembly (4) from cylinder (3).

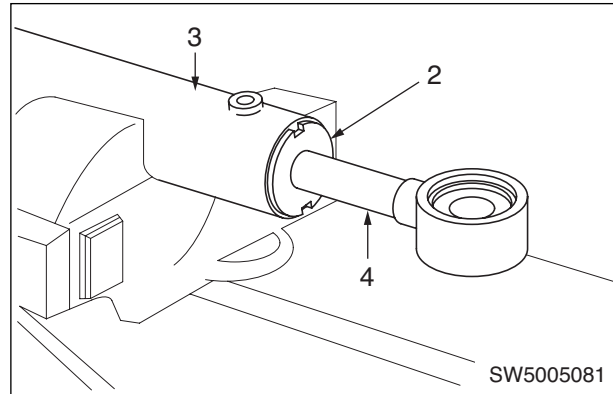

2. Piston

- 1) Remove nut (5) and withdraw piston (6) from the rod.

★ Clamp the piston rod in a vice.

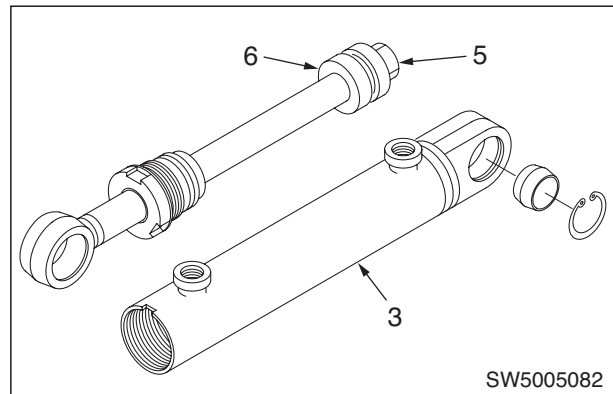

- 2) Remove seal ring (8) from piston (6).

3. End cap

- 1) Pull off end cap (2) from piston rod (9).

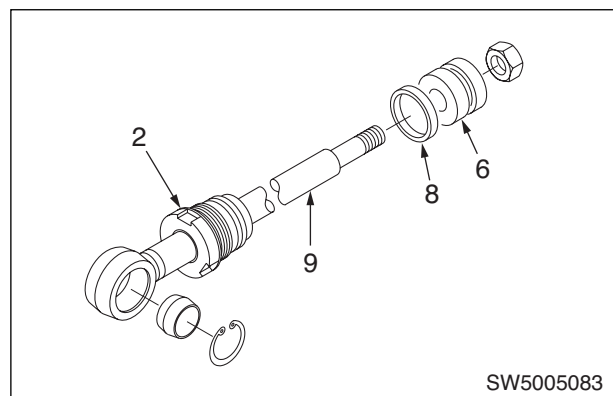

- 2) Remove U-ring (10) and dust seal (12) from end cap (2).

- 3) Remove O-ring (13) from end cap (2).

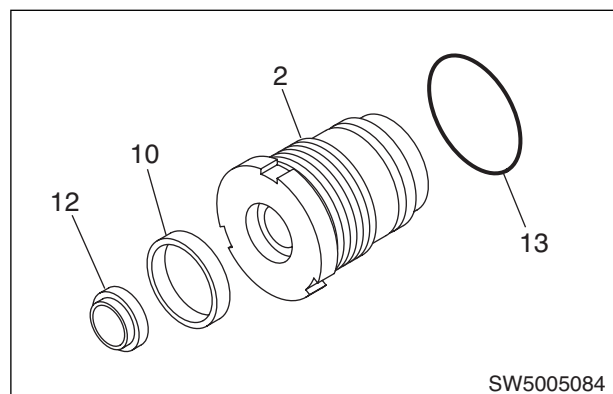

15-2. Assembly of steering cylinder assembly

★ Thoroughly clean the component parts.
Remove burrs etc.

★ When assembling, apply a coat of engine oil to the running surfaces.

1. Cylinder head

- 1) Install O-ring (13) to end cap (2).
- 2) Fit dust seal (12) and U-ring (10) to end cap (2).

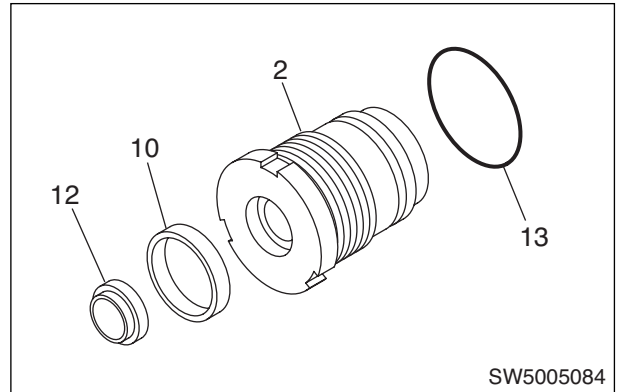

- 3) Fit end cap (2) on piston rod (9).

2. Piston

- 1) Assemble seal ring (8) onto piston (6) and fit the assembly onto piston rod (9).

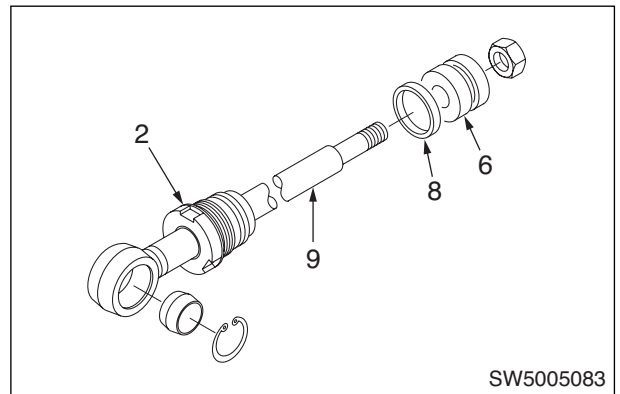

- 2) Tighten nut (5).

• Tightening torque: $30 \pm 5 \text{ kgf}\cdot\text{m}$
($294 \pm 49 \text{ N}\cdot\text{m}$)

★ Mount the piston rod on a vice.

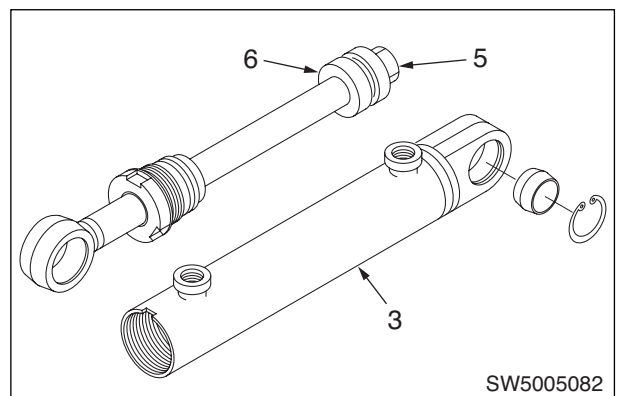

3. Piston-piston rod ass'y

- 1) Assemble piston-piston rod assembly (4) into cylinder (3).
- 2) Screw end cap (2) into cylinder (3) until tight.
★ Secure the cylinder in a vice.
- 3) Bend down lock washer toward the piston rod eye.

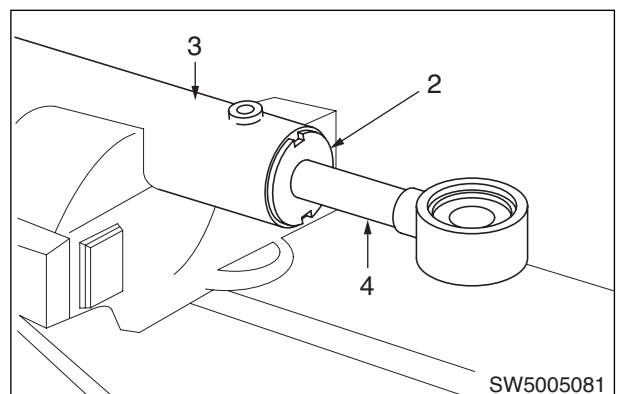

16. Removal and Installation of Steering Wheel

16-1. Removal of steering wheel

1. Contact plate

Remove horn cap (1) from the steering wheel and remove contact plate (2), lock spring (3) and spring (4).

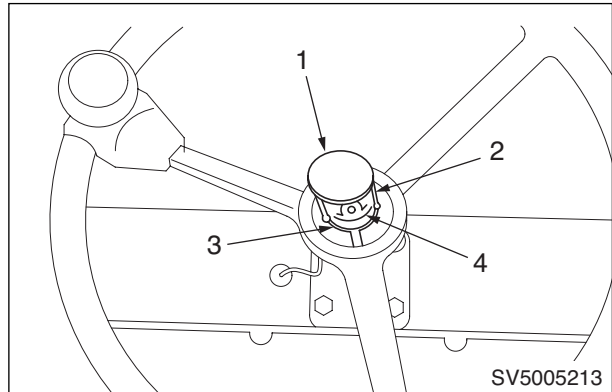

2. Steering wheel

Remove nut (5) and remove steering wheel (6).

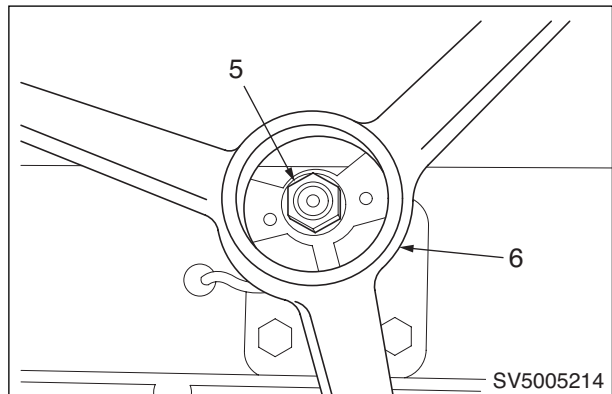

16-2. Instration of steering wheel

★ Installation is the reverse of the removal procedure.

17. Removal and installation of Orbitrol

17-1. Removal of Orbitrol

1. Cover

Remove the cover under the instrument panel.

2. Orbitrol

1) Disconnect four hoses (2).

★ **Before disconnection, label the hoses for correct reconnection.**

★ **Plug the open ends of the hoses and openings of Orbitrol.**

2) Remove four bolts (3) and remove steering wheel assembly (4) together with Orbitrol (5).

* Hold Orbitrol by hand, as it can fall free when the steering wheel is detached.

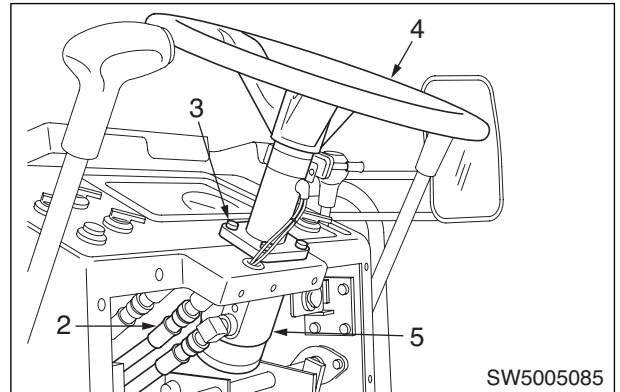

17-2. Installation of Orbitrol

★ Reverse the removal instructions.

★ Add oil to the tank to make up for a leak.

★ Start the engine and let oil circulate through the piping. Then recheck the oil level.

No. 98084-0

SAKAI HEAVY INDUSTRIES, LTD.

Head office: 1-4-8, Shiba-Daimon, Minato-ku
Tokyo, Japan

Telephone: Tokyo(03) 3431-9971

Facsimile: (03) 3431-6212