

⚠ Read this handbook thoroughly and understand the whole information contained before trying to operate, inspect and service your machine!

**OPERATING &
MAINTENANCE
INSTRUCTIONS**

**VIBRATING
ROLLER**

MODEL

TW320 -1

TW330 -1

From TW320-1 → 4TW50 — 40104~
TW330-1 → 4TW51 — 40104~

PREFACE

This operator's manual serves as a guide for the use of your Sakai TW320-1, TW330-1 Vibrating Roller for those who are new to the machine, and also for the people who have experience in using the Machine and want to refresh their knowledge for the machine.

Read this manual thoroughly and try to fully understand the information before operating your machine. Keep this handbook at hand whenever you do your work.

The main subjects of this manual are:

(1) Basic precautions for safety, (2) Operation, (3) Daily maintenance and (4) Specifications. For operation and maintenance of the engine, refer to the Engine Instruction Manual furnished separately. Descriptions in this manual can differ from the machine instructions of your machine due to the results of the investigation and improvement in its design. If you have any inquiry regarding your Machine or this manual, contact our distributors.

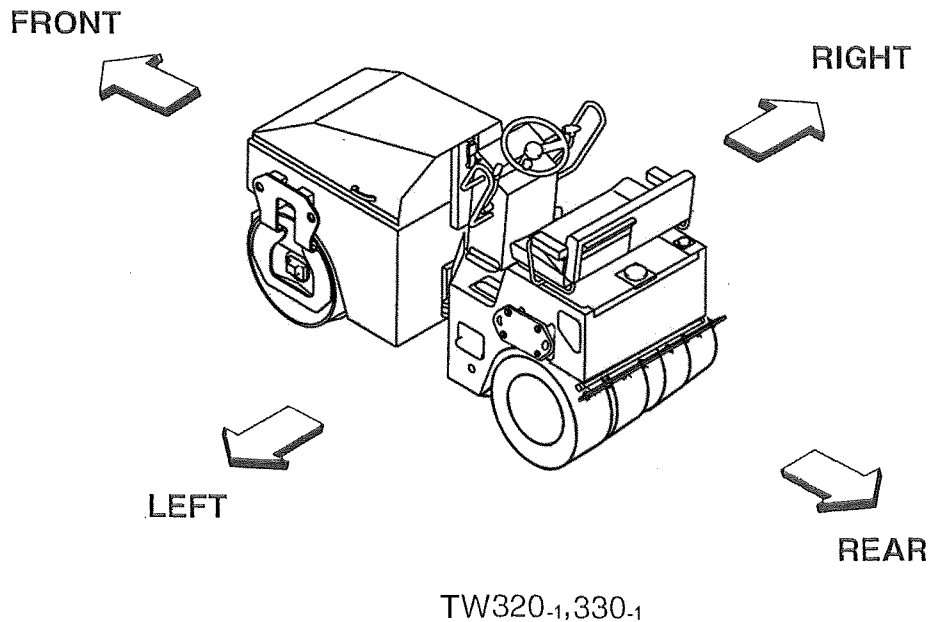

CONTENTS

PREFACE

MACHINE AND ENGINE IDENTIFICATION NUMBERS 1
SAFETY NOTICES 2

1. BASIC PRECAUTIONS FOR SAFETY

1.1 General Precautions 4
1.2 Preparation for Safe Operation..... 6
1.3 Before Starting the Engine 7
1.4 After Starting the Engine 8
1.5 During operation..... 8
1.6 Loading and Unloading10
1.7 Transportation11
1.8 Handling the Battery.....11
1.9 Towing12
1.10 Before Servicing13
1.11 During Servicing.....14
1.12 Safety Decals16

2. OPERATION

2.1 Instruments and Controls18
2.1.1 Operator's station18
2.1.2 Gauges, indicator lamps and warning lamps.....19
2.1.3 Switches21
2.1.4 Operating levers and pedals24
2.1.5 Fuse box25
2.2 Handling and Adjustments25
2.2.1 Seat adjustment.....25
2.2.2 Scraper adjustment and replacement.....26
2.2.3 Disengaging the brake when towing.....27
2.3 Operation28
2.3.1 Before-starting inspection28
2.3.2 Starting the engine29
2.3.3 After starting the engine30
2.3.4 Traveling31
2.3.5 Stopping / Parking32
2.3.6 Stopping the Engine33
2.3.7 Check after Stopping the Engine33
2.4 Vibratory Operation34

2.5	Sprinkler	35
2.6	Liquid Sprayer.....	38
2.7	Precautions for Work.....	39
2.7.1	Compaction operation	39
2.7.2	When going downhill	39
2.7.3	On a slope	39
2.8	Applicable Jobs	40
2.9	After Operation.....	40
2.10	Loading and Unloading	41
2.10.1	Use of a trailer equipped with a winch.....	41
2.10.2	Self-propelling.....	42
2.10.3	Use of a hoist.....	43
2.11	After Loading the Machine	44
2.12	Transportation	44
2.13	Operation in Cold Weather	44
2.13.1	Fuel oil and grease	44
2.13.2	Coolant	45
2.13.3	Battery	46
2.14	When the Cold Season is Over	46
2.15	For a Long Storage Period	47
2.16	During the Storage Period.....	47
2.17	When the Battery Has Discharged.....	48
2.17.1	Connection and disconnection of booster cables	49
3.	PERIODICAL MAINTENANCE	
3.1	Precautions	50
3.2	Walk-Around Checking.....	52
3.3	Periodical Maintenance Points	53
3.4	Maintenance Procedure	56
(1)	Every 10 hours or daily	56
(2)	Every 100 hours	58
(3)	Every 200 hours	58
(4)	Every 250 hours	59
(5)	Every 450 hours	59
(6)	Every 500 hours	59
(7)	Every 1000 hours	61
(8)	As required	71
3.5	Consumable Parts	75
3.6	Feeding Water and Lubricants	76
3.7	Electric Wiring Diagram.....	78
4.	SPECIFICATIONS	80

MACHINE AND ENGINE IDENTIFICATION NUMBERS

When ordering parts or making inquiries about your machine, the following information is requested:

(1) Machine model

Indicated on the dashboard in the operator's station.

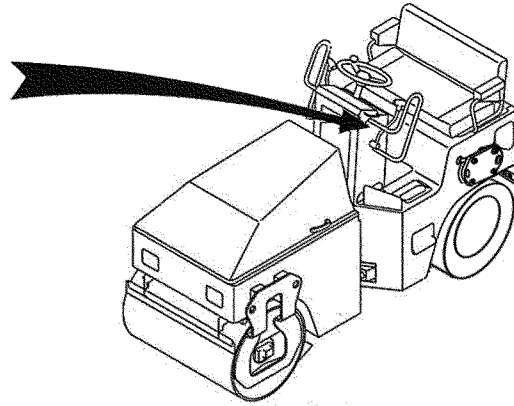

(2) Machine serial number

TW320-1 ⇨ 4TW50 -○○○○○
TW330-1 ⇨ 4TW51 -○○○○○

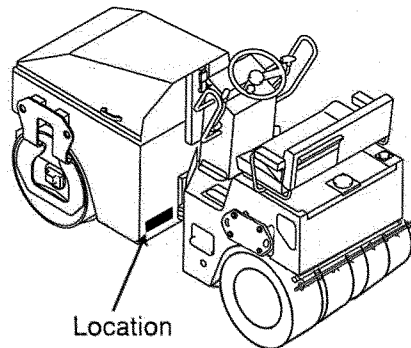

(3) Engine serial number

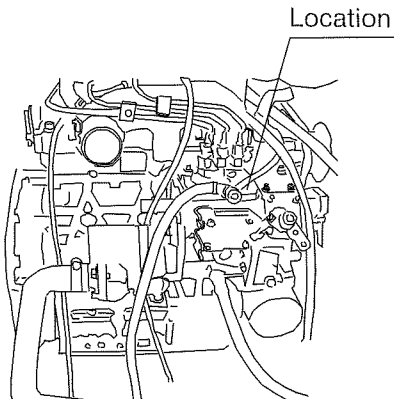

SAFETY NOTICES

For the safe use of your machine, correct handling and periodical maintenance are of utmost importance. Thoroughly read the safety precautions described in this manual. Do not attempt to operate and maintain your machine until you gain a full understanding of these safety statements.

This manual covers the proper and safe method of driving and handling of this machine for its intended use. When this machine is used a manner, other than that covered in this manual, you must assume responsibility for your own personal safety.

In this manual and on the machine, you will find safety notices. Each safety notice starts with a signal word as shown below:



DANGER

Denotes that there is an extreme hazard. If you fail to take proper precautions, it is highly likely that you could be killed or seriously injured (The color of the symbol  is red).



WARNING

Denotes that there is a hazard. If you fail to take proper precautions, you could be killed or seriously injured (Symbol  is orange).



CAUTION

Calls attention to safety practices. If you fail to take proper precautions, you could be injured or cause damage to the machine (Symbol  is yellow).

It is almost impossible for the safety notices in this manual and or the machine to cover all the potential dangers. Keep alert to possible dangers not mentioned in this manual and on the decals.

 **WARNING**

Do not operate your machine before you read its operator's manual thoroughly.

Incorrect operation can kill or cause injury.

It is your responsibility to operate the machine safely.

- ☆ Non-approved modifications can pose safety-related problems. Before making any modifications, consult your distributor. For an injury or damage to the machine caused by non-approved modifications, Sakai accepts no responsibility.
- ☆ Basic precautions for safe operation of your machine are discussed beginning on page 4.
- ☆ To operate and work with your machine, you must be qualified.

1. BASIC PRECAUTIONS FOR SAFETY

1. BASIC PRECAUTIONS FOR SAFETY

1.1 General Precautions

■ **Read thoroughly the operator's manual.**

- Understand the functions of the controls and gauges. Familiarize yourself with their location and how to operate them. Understand the meaning of all the symbols.



■ **Obey the worksite rules.**

- Follow the worksite rules such as matters forbidden or to be attended to, and working procedures.

■ **Wear protective clothing to suit the work.**

- Wear clothing, safety shoes and hard hat to suit your work.
- Do not wear clothing and accessories that tend to get caught in the controls or protruded portions of the machine. Do not wear oily clothing.
- According to the type of jobs, wear safety goggles or mask.



■ **Know the work area in advance.**

- Know the terrain, geology and conditions of the road surface at the worksite. Start working after securing safety such as stationing a guardsman or putting up barriers where there is a risk of falling of the machine or collapse of shoulder.

■ **Provide against an accident.**

- Decide in advance the means of communication in an emergency. Know the location and use of an extinguisher and first-aid kit.

■ **Know the capability of the machine.**

- Thoroughly understand the performance of your machine and correctly operate the machine to meet the requirements of the job site. Operating the machine beyond its capabilities may lead to an accident. Use your machine within its capability.

⚠ WARNING: Negligence of these instructions can lead to accidents.

1. BASIC PRECAUTIONS FOR SAFETY

■ Do not use a machine which has not been serviced correctly at regular intervals.

- Before working, perform necessary inspections. Start operation only after making certain the machine is in good operating condition. If found to be abnormal, report to the responsible person and have the fault corrected. Operate the machine after making sure that it is safe to operate.

■ Do not allow anyone to enter the work area except for authorized personnel.

- Always conduct the work paying attention to the workers around the machine.



■ Be careful of hot parts.

- After your machine has operated for some time, the coolant, engine oil and hydraulic fluid will become hot and the pressure will build up. If, in this state, you try to remove the filler caps, drain the oil or replace the filters, you can get burned. Perform this work in accordance with the correct procedures with the machine cooled down.
- To remove the radiator cap, slowly loosen the cap to relieve the pressure with the engine shut down and the coolant cooled down. (For the radiator cap with a lever, lift the lever to release the trapped pressure.)
- When removing the filler cap on the hydraulic tank, release the trapped pressure by turning it out slowly to prevent the oil from gushing out.
- Do not touch the muffler while the engine is running or immediately after it has been shut down. You can get burned.

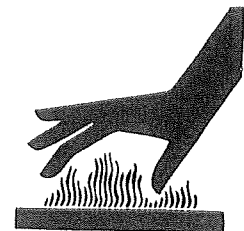

■ Be careful with fire.

- The fuel, oil, and anti-freeze will catch fire if open flames or ignition sources are used close to them. Particularly, the fuel is highly flammable.
- Do not smoke or use a match or cigarette lighter close to inflammables (combustibles).
- When refueling, stop the engine and do not smoke.
- The filler caps of the fuel and oil tanks must be kept tight.

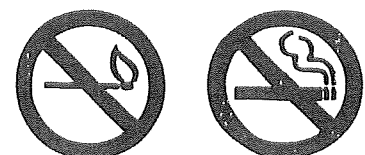

⚠ WARNING: Negligence of these instructions can lead to accidents.

1. BASIC PRECAUTIONS FOR SAFETY

■ Mount on or dismount from your machine after it has come to a complete stop.

- For getting on and off, face the machine and use the handrail and step.
- Do not jump on or off a machine, particularly when it is moving.

■ To handle the hydraulic fluid.

- Wear safety goggles to protect your eyes from contact with hydraulic fluid. It can irritate your eyes.
If the fluid contacts your eyes, flush with clean water for 15 minutes and get medical aid.
- The fluid can also irritate your skin. When handling it, wear rubber gloves to avoid contact with it. In case of skin contact, wash with soap and water.
- Be careful not to swallow the fluid. It can cause diarrhea and emesis.
If swallowed, do not try to vomit. Get medical help immediately.



1.2 Preparation for Safe Operation

■ Clean the step, operator's station and floor board.

- Do not place parts, tools or unnecessary articles on the step, operator's station and floor board.
- Keep the step, floor board, controls and handholds free from muds, oil, ice or water, as they can cause slippage. Repair them if found to be damaged. Tighten loose bolts.
- Keep your boot soles free of oil or muds. They can slip, leading to an accident.

■ Inspect your machine before operation

- Check your machine for damage such as cracks and deformation. If found to be abnormal, operate the machine after taking a proper measure to secure safety.
- Check the level of fluids (fuel, engine oil, coolant, anti-freeze and hydraulic oil). Add as necessary.
- Check the area where the machine has parked for signs of leakage of oil, fuel and water. If any leakage is noticeable, determine the cause and make corrections immediately.

⚠ WARNING: Negligence of these instructions can lead to accidents.

1. BASIC PRECAUTIONS FOR SAFETY

■ Know the stopping distance.

- When traveling on a road, bear in mind the stopping distance. Avoid excessive speed, and abrupt starting and stopping, and moving in a zigzag direction.

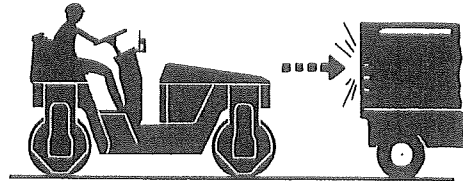

1.3 Before Starting the Engine

■ Adjust the operator's seat to your most effective operating position.

- Sit on the operator's seat. Adjust the seat so that your back will make contact with the seat back when the brake pedal is depressed to the full extent. Check to be sure that the brake pedal can be fully depressed without difficulty when you twist your body for reverse run.

■ Secure good visibility (with canopy)

- Keep the windowpane clean.
- Lock the windows and doors no matter whether they are open or closed.
- Do not leave the doors half-closed.

■ Secure forward and backward visibilities.

- Adjust the rear view mirrors and under mirrors for good visibility. If dirty, clean them. If damaged, replace.

■ Check that the horn, lamps and gauges work correctly.

■ Before starting, make certain that each lever is in the neutral position and the parking brake is applied.

■ When starting, sound the horn.

- Before starting the engine. Make sure there is no one in the immediate vicinity and there are no obstructions around the machine.



⚠ WARNING: Negligence of these instructions can lead to accidents.

1. BASIC PRECAUTIONS FOR SAFETY

■ Pay attention to ventilation.

- Exhaust fumes are dangerous if breathed in. When starting the engine in an enclosed area, provide good ventilation with windows and doors opened.

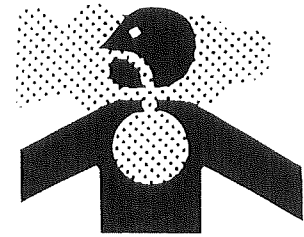

■ Do not stand close to the exhaust gas pipe opening.

- Exhaust fumes are noxious if breathed in.

1.4 After Starting the Engine

■ Secure safety around the machine.

- Ensure that the area around the machine is clear of personnel and obstructions. Pay particular attention to dead spaces. Before starting, sound the horn.



■ Warm up the Engine

- Do not put your machine into motion immediately after the engine has started, let it idle for several minutes until it is at operating temperature.

■ Have a trial run.

- Make a test run in a safe place to check that there are no abnormal signs. If found to be abnormal, rectify the fault before traveling again.
- Listen for unusual sounds, and check for abnormal temperature rise. If abnormal, park the machine in a safe location and find the source of trouble before operating.

1.5 During Operation

■ No other person but the operator

- This machine is a one-man roller. Do not allow anyone to get on. Only the operator is allowed on this machine while it is running or in operation. Radios are not permitted.

■ Before mounting, be sure areas around the machine are safe.

- Before getting on the machine, make certain that there are no obstacles around the machine and no workers under it. If some workers are present or close to the machine, tell them that the machine is about to move, warning them to stay away from it.

⚠ WARNING: Negligence of these instructions can lead to accidents.

1. BASIC PRECAUTIONS FOR SAFETY

■ Do not try to get on or off a moving machine.

- Get on or off the machine after making sure it has come to a complete stop.

■ To go uphill or downhill, run at low speeds. Do not attempt to shift speeds while traveling on a grade.

- Shifting speeds on a slope can cause unexpected running down the slope.
- Going down hill at speeds other than low range can cause the machine to run down violently.

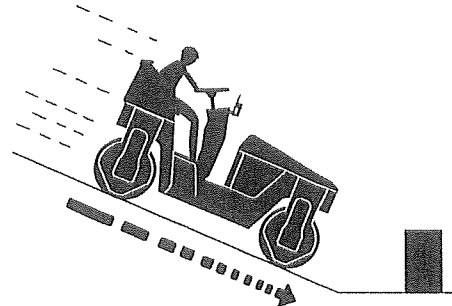

■ Refrain from inattentive driving.

- Inattentive driving or driving relying on guess work can cause an accident. Use extreme care for workers present in the path of the roller or around it. In case of danger, stop and sound the horn, and proceed when the area is clear of personnel or obstructions.

■ When changing the direction of travel, secure the safety on the path in the travel direction.

■ Keep everyone away from the pinch points.

- When making turns, do not allow anyone to come close to the pinch point.

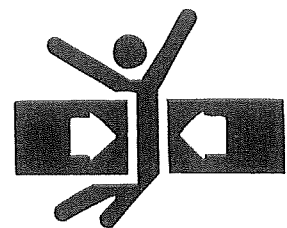

■ At night, carefully drive the machine.

- Nighttime driving tends to frustrate the sense of distance. Carefully drive the machine at a speed suited to illumination. Keep the headlamps and flood lamps lighted. If necessary, provide extra lighting in the work area.

■ Repair as soon as possible if found to be defective.

- If the machine is found to be faulty, stop the machine and repair. Do not operate the machine until the problem is corrected. When any warning lamp indicates faulty operation, inspect the machine after moving it to the nearest safe location.

⚠ WARNING: Negligence of these instructions can lead to accidents.

1. BASIC PRECAUTIONS FOR SAFETY

- Do not operate the machine except from the operator's seat. Do not drive in a standing posture.
- While making turns, do not run at abnormally high speed and do not turn the steering wheel abruptly and sharply.
- For the traveling on structures such as a bridge, make certain that they can support your machine. Before traveling on the structure, you must know the load capacity of the structure and the load weight of the machine you are operating to insure safe travel across the structure.
- Do not make turns on a slope and do not travel across sidehill. If necessary to do so, go down straight along the slope to the flat ground, move sideways and go up straight to the destination.

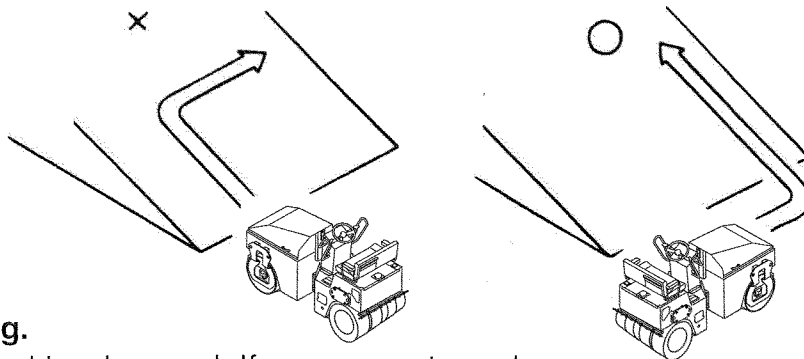

■ When parking.

- Select level and hard ground. If necessary to park on a slope, block the front of the drums on the downside of the slope.
- When required to park on the public road, provide necessary markings such as flag, barriers and illumination. However, be sure they do not obstruct traffic.
- When getting off the machine, stop the engine and remove the key from the ignition switch.

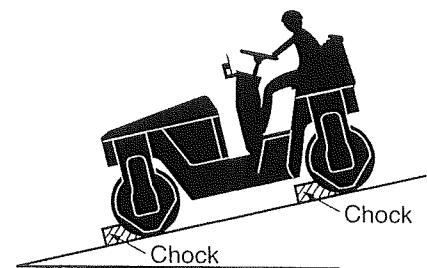

1.6 Loading and Unloading

- Loading and unloading can accompany any danger. Use extreme care.
- Select level and hard ground leaving a sufficient distance from the shoulder.
- Use sturdy ramps with proper width, length and thickness which allow safe loading and unloading. If they deflect considerably under load, apply wooden blocks to reinforce the ramps.

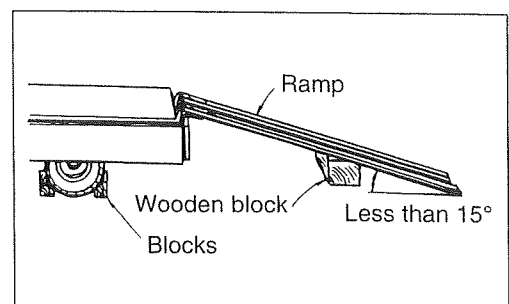

⚠ WARNING: Negligence of these instructions can lead to accidents.

1. BASIC PRECAUTIONS FOR SAFETY

- To prevent your machine from crosswise slippage, keep the ramps free from oil, mud, debris, etc. The drum must also be free from extraneous matter that can cause slippage.
- Do not steer your machine on the ramps. If the machine is facing in the wrong direction, allow it to dismount from the ramps, correct the direction and try again.
- Do not use kinked, twisted or damaged wirerores for crane or winch operation. Use ones with ample strength.
- When loading is complete, fix the machine with wooden blocks placed under the drums and chains fastened to the machine.

1.7 Transportation

- Follow required regulations.
- Select a transporting route according to the overall width, overall height and gross weight of the trailer with the roller loaded.

1.8 Handling the Battery

■ When handling the battery:

- Battery electrolyte contains sulphuric acid. It will destroy clothing and skin. If it touches your clothing or skin, flush with large quantities of water.
- In case of eye contact, flush with clean water and seek medical help.
- If swallowed, drink large amount of water, milk, beaten egg or vegetable oil, and get medical help.
- Wear safety goggles when handling the battery.
Wear safety goggles, full face shield, rubber gloves and rubber apron when adding fluids to the battery.
- The battery generates flammable gases that can cause an explosion. Do not smoke close to the battery. Keep the battery away from flames, sparks and ignition sources.

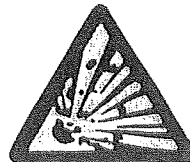

⚠ WARNING

Battery posts, terminals, and related accessories contain lead and lead compounds, chemicals known to the State of California to cause cancer and reproductive harm.

Wash hand after handling.

1. BASIC PRECAUTIONS FOR SAFETY

- Inspect or handle the battery with the engine shut down and the starter key in the OFF position.
- Keep metallic items such as tools away from the battery terminals.
- Loose terminals can cause sparks leading to an explosion. Secure the terminals tightly.

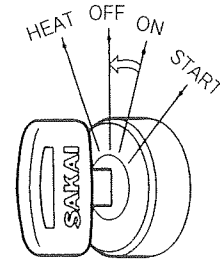

■ Jump-starting the engine.

- Wear safety goggles when jump-starting the machine.
- When starting from another machine, do not allow the two machines to make contact with each other.
- When connecting the battery cables, start with the positive terminal. For disconnection, start with the negative one.
- Do not allow a tool to bridge between the positive terminal and machine body. This can generate dangerous sparks.
- Do not connect the booster cable to wrong terminal. NEVER connect the positive terminal to the negative.
- Final connection to the engine block of the disabled machine can cause sparks. The connecting point should be as far as possible from the battery.

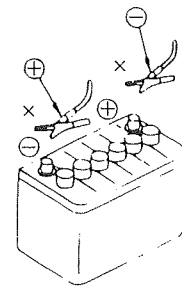

1.9 Towing

- To tow the machine, use wire ropes with ample strength.
- Do not perform towing on a slope.
- Do not use towing ropes twisted, kinked or damaged.
- Do not stride towing cables.
- Keep everyone away from the space between the machine and the towing vehicle when connecting the two.
- Align the connecting portions of the machine and towing vehicle straight when coupling the machine.

⚠ WARNING: Negligence of these instructions can lead to accidents.

1. BASIC PRECAUTIONS FOR SAFETY

1.10 Before Servicing

■ Attach warning tags when servicing the machine.

- Serious accidents can occur if the machine is unexpectedly started or controls carelessly touched by an unauthorized person.
- Attach a warning tag at a clearly visible location in the operator's station and insure the key has been removed from the ignition switch.



■ Use proper tools.

- It is very dangerous to use damaged or deteriorated tools or to use tools for other purposes than intended. Use correct tools for their intended use only.

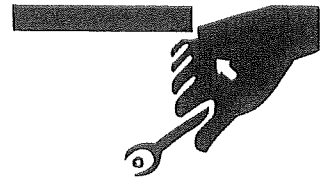

■ Change safety-related parts at regular intervals.

- Replace fuel hose and high pressure hydraulic hoses regularly to prevent fire. Replace high pressure hoses of the power steering system every two years.
 - ☆ Change these parts at regular intervals even if found to be normal. They will deteriorate as time goes on.
 - ☆ Change any hose found to be abnormal even if it is within its recommended service interval.

■ Inspect or service your machine with the engine stopped.

- If required to keep the engine running in such a case as radiator interior cleaning, perform the work with two persons. One of them should sit on the operator's seat getting ready for shutting down the engine. He must take care not to touch any of controls carelessly. Maintenance personnel must exercise extreme caution not to make contact with moving parts.

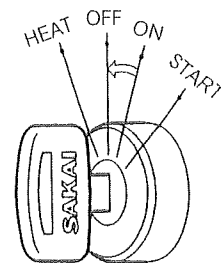

⚠ WARNING: Negligence of these instructions can lead to accidents.

1. BASIC PRECAUTIONS FOR SAFETY

■ Supplying fuel and oils

- Spilled fuel or oil will be slippery. Wipe up immediately. Keep the filler caps tight. Do not use fuel for flushing oil. Handle fuel and oil in a well ventilated area.

■ Check the coolant level in the radiator.

- To check the coolant level, shut down the engine and allow the engine and radiator to cool down.

■ Illumination

- For inspecting the level of the fuel, oil, coolant and battery electrolyte, use burn-proof illuminations. Failure to use this type of illumination can result in an explosion.

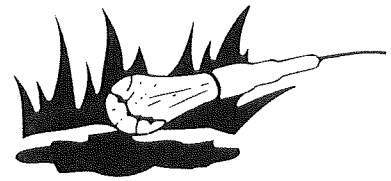

1.11 During servicing

■ Keep unauthorized persons away

- During service, do not allow persons not concerned to enter the work area, particularly when grinding or welding operation is performed or heavy hammers are being used.



■ Keep your machine clean

- Spilled oil, grease or scattered debris are dangerous. Always keep your machine clean. Moisture that penetrates into the electrical system can cause malfunctions. Do not use water to clean sensors, connectors and the operator's station.

■ When repairing the electrical system

- For repairing the electrical system or for conducting welding, disconnect the negative cable from the battery to shut off the electricity.



■ Carefully handle high pressure hoses.

- Do not try to bend or hit hoses against a hard object. Do not use hoses or pipes that are bent or damaged. They will burst.
- Replace damaged fuel hose and hydraulic hoses. An oil or hydraulic fluid spill can cause a fire.

⚠ WARNING: Negligence of these instructions can lead to accidents.

1. BASIC PRECAUTIONS FOR SAFETY

■ Be careful of high pressure hydraulic fluid.

- Bear in mind that the working equipment hydraulic systems are under internal pressure. Do not perform adding, draining, inspection or servicing of the hydraulic systems until the internal pressure has been relieved. Hydraulic fluid leaking through a fine hole at high pressure can penetrate your skin and eyes. Inspect leakage by holding a hard board close to suspected leaks wearing goggles. If affected by high pressure oil, get medical help immediately.

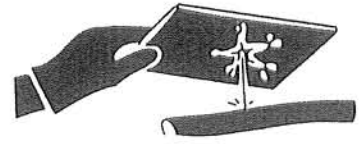

■ Be careful of hot parts

- After the machine has been operated for some time, the coolant, engine oil and hydraulic fluid will become hot.
- Removing the radiator cap or draining the coolant or oil can burn you. Perform this work in accordance with correct procedures after the systems have cooled down.

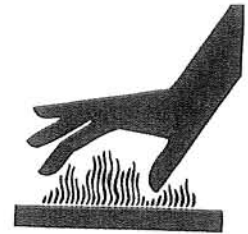

■ Use care when inspecting or servicing fan or belts in motion

- Secure loose clothing and keep articles away that could get caught in moving parts.
- Do not let your body or tools make contact with the fan blades or belts. They can be cut seriously.

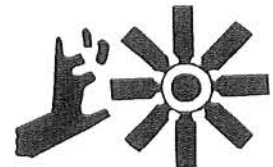

■ Used oil disposal

- Do not throw used oil into a drain or waterway. Drain the oil from the machine into a proper container. Do not drain directly on the ground.
- Obey all local, state and federal environment regulations for the proper disposal of oil, fuel, coolant, battery electrolyte or any other fluids.

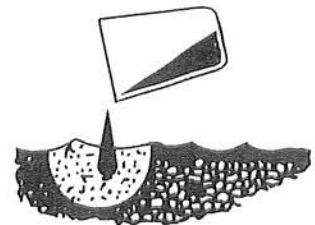

⚠ WARNING: Negligence of these instructions can lead to accidents.

1. BASIC PRECAUTIONS FOR SAFETY

1.12 Safety Decals

Keep all decals clean. If lost, replace with new one. There are decals other than those shown below: Treat them in the same manner as the one shown here.

① 1202-19063-0

⚠ DANGER
<p>1. Precautions for operation: To secure safety around machine, use switches when putting machine in motion. For self-propelled transport, lift operator's seat. Use the handrails and steps when boarding and getting off. Never carry passengers. Never attempt to board or get off the machine while it is moving.</p> <p>2. Preparation for Safe Operation Clean the steps, operator's station and floorboards. Obey the work site rules. Safety accepts no responsibility for any injury or damage to the machine caused by unapproved modification. Do not use a machine which needs repair or maintenance. Sound the horn immediately prior to starting the engine to warn people in the vicinity.</p> <p>3. Starting the Engine Check that all operating levers are in the neutral position. Idle the engine for about 5 minutes to warm it up prior to commencing work.</p> <p>4. Parking Precautions When parking the machine, park on level ground, set the parking switch and set the roller chocks. Allow the engine to cool off by running it for about 5 minutes before stopping. When getting off the machine, remove the key from the ignition switch.</p> <p>5. Precautions to Avoid the Machine Rolling Over Do not work in the vicinity of overhanging banks, or on grades steep enough to cause the machine to slide or roll over. Reduce speed prior to making a turn. Pay particular attention when operating on uneven surfaces, as the machine may become unstable.</p> <p style="text-align: right;"><small>1202-19063-0</small></p>

⑤ 3998-16489-0

<p>CALIFORNIA Proposition 65 Warning</p> <p>Diesel engine and some of its constituents are known to the State of California to cause cancer, birth defects, and other reproductive harm.</p>

⑧ 3998-36002-0 (2 locations)



⑥ 3998-16500-0

⚠ WARNING
<p>Avoid inhalation of exhaust gas. Avoid contact with exhaust pipe while engine is running and after it has been stopped. Contact with hot exhaust pipe will cause burns.</p> <p style="text-align: right;"><small>3998-16500-0</small></p>

⑨ 3998-16502-0

⚠ DANGER
<p>Do not approach, or allow objects to touch, the rotating parts. Body parts contacting rotating mechanism will be severed.</p>
<p>Do not open the radiator cap when fluid is hot. Radiator fluid is flammable. Avoid exposure to flame when radiator cap has been removed.</p>
<p>Avoid contact with the machine parts in the vicinity of the engine while engine is running and after it has been stopped. Contact with hot parts will cause burns.</p> <p style="text-align: right;"><small>3998-16502-0</small></p>

② 1202-19062-0

⚠ DANGER
<p>When coolant is hot, do not open radiator filler cap. Coolant is flammable. Do not bring an open flame close to it.</p> <p style="text-align: right;"><small>1202-19062-0</small></p>

⑦ 3998-16501-0

⚠ DANGER
<p>Be Careful with Fire When refueling, stop the engine and do not do not smoke. The filler cap of the fuel tank must be kept tight.</p> <p style="text-align: right;"><small>3998-16501-0</small></p>

⑩ 3998-16559-0

<p>DANGER EXPLOSIVE GASES Cigarettes, flames or sparks could cause battery to explode. Always shield eyes and face from battery. Do not charge or use booster cables or adjust post connections without proper instruction and training. KEEP VENT CAPS TIGHT AND LEVEL</p> <p>POISON CAUSES SEVERE BURNS Contains sulfuric acid. Avoid contact with skin, eyes or clothing in event of accident. Flush with water and call a physician immediately. KEEP OUT OF REACH OF CHILDREN</p> <p style="text-align: right;"><small>3998-16559-0</small></p>
--

③ 3998-16505-0

⚠ DANGER
<p>Roll Over Prevention Do not work in the vicinity of overhanging banks, or on grades steep enough to cause the machine to slide or roll over. Reduce speed prior to making turns. Pay particular attention when operating on uneven surfaces, as the machine may become unstable.</p> <p style="text-align: right;"><small>3998-16505-0</small></p>

④ 3998-16491-1

⚠ WARNING
<p>Read the operator's manual thoroughly before operating the machine. Incorrect operation can cause severe injury or death. It is your responsibility to operate the machine safely.</p> <p style="text-align: right;"><small>3998-16491-1</small></p>

⚠ WARNING: Negligence of these instructions can lead to accidents.

1. BASIC PRECAUTIONS FOR SAFETY

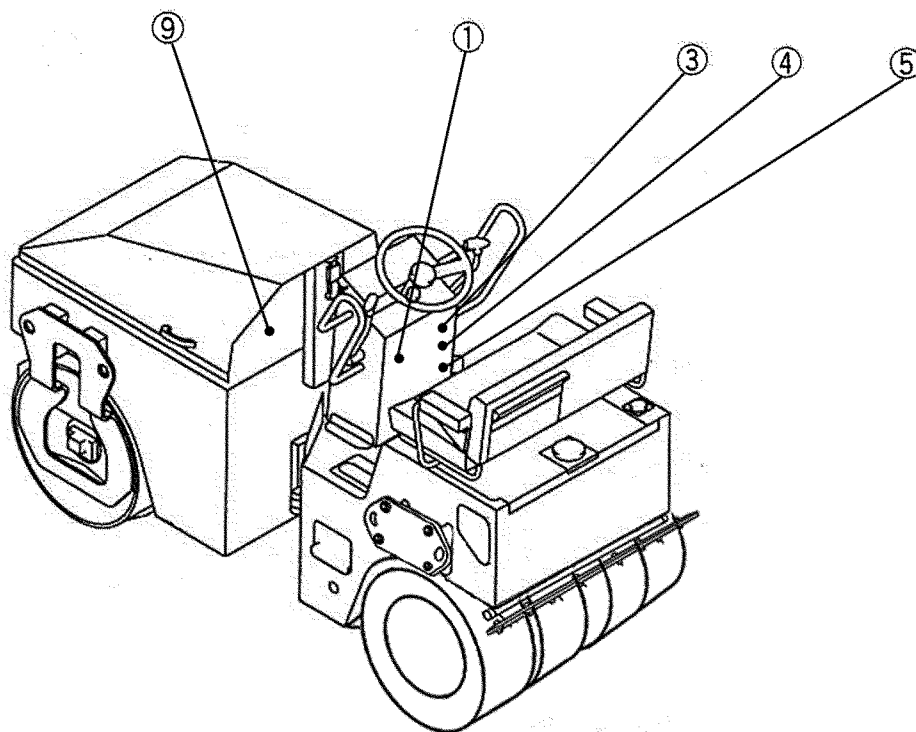
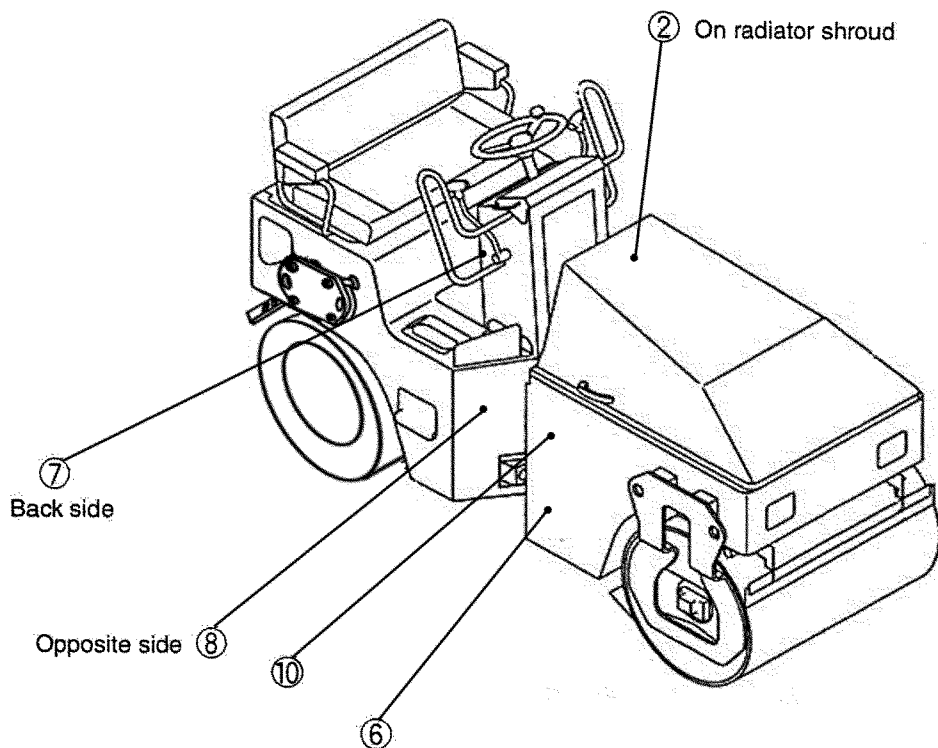

2. OPERATION

2. OPERATION

2.1 Instruments and Controls

2.1.1 Operator's station

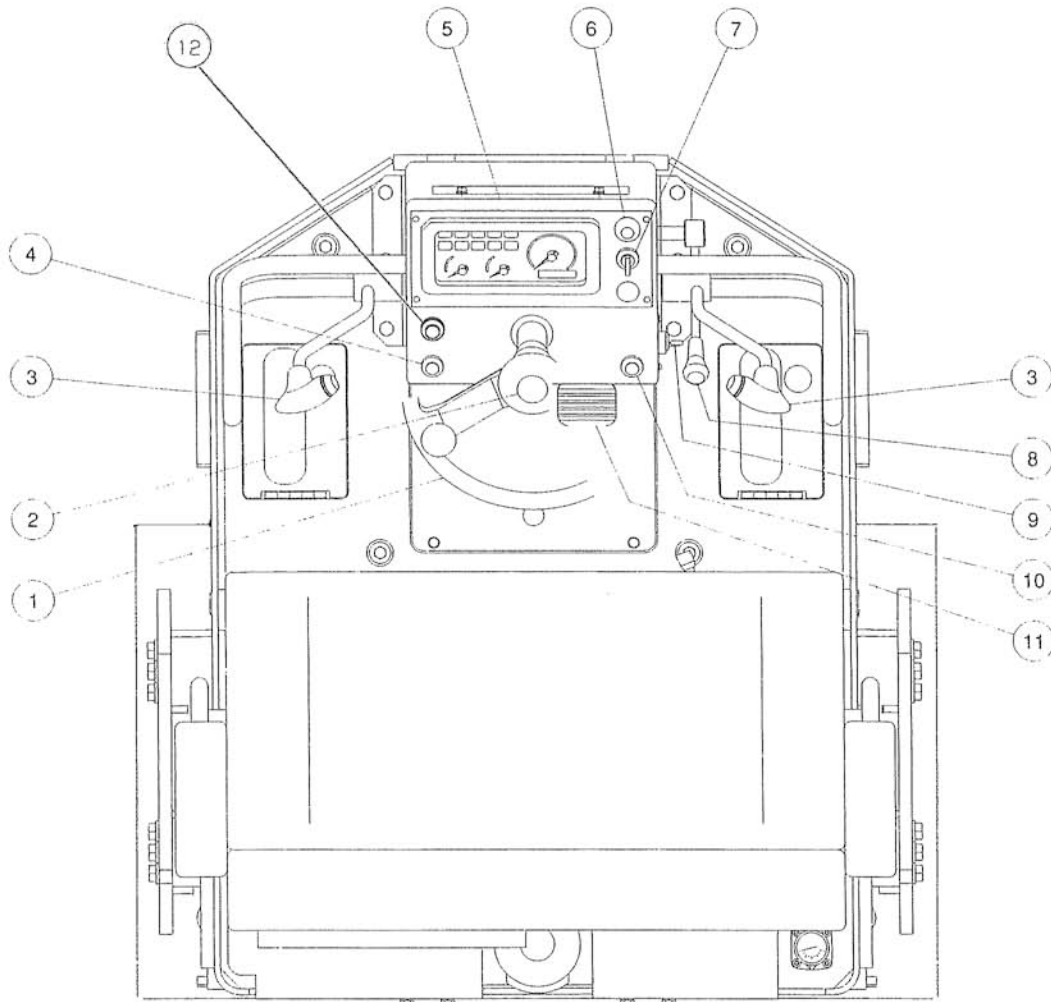

- | | |
|---|-----------------------|
| ① Steering wheel | ⑦ Vibrator switch |
| ② Horn switch | ⑧ Throttle lever |
| ③ Forward-Reverse lever (F-R lever)
with vibrator switch | ⑨ Starter switch |
| ④ Lamp switch | ⑩ Sprinkler switch |
| ⑤ Combination meter | ⑪ Brake pedal |
| ⑥ Parking brake switch | ⑫ Liquid spray switch |

2.1.2 Gauges, indicator lamps and warning lamps

For safe execution of your job, fully understand the role and function of the systems involved.

Combination meter

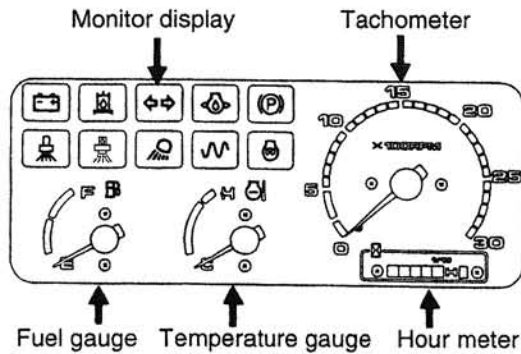

Tachometer / Hour meter

Indicates the engine RPM. The hour meter shows total operating hours. The service interval recommendation in this manual should be based upon the hour meter readings.

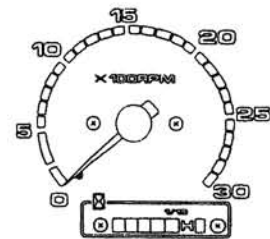

Tachometer/Hour meter

Temperature gauge

Indicates the coolant temperature. Zone close to symbol H indicates overheating. In case of overheating, run the engine at idling for about ten minutes before shutting it down. Then determine the cause.

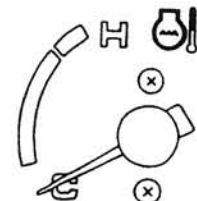

Temperature gauge

Fuel gauge

Indicates the fuel level in the tank.

E: The tank is empty.

F: The tank is full.

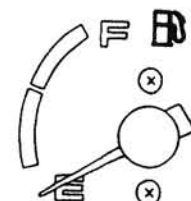



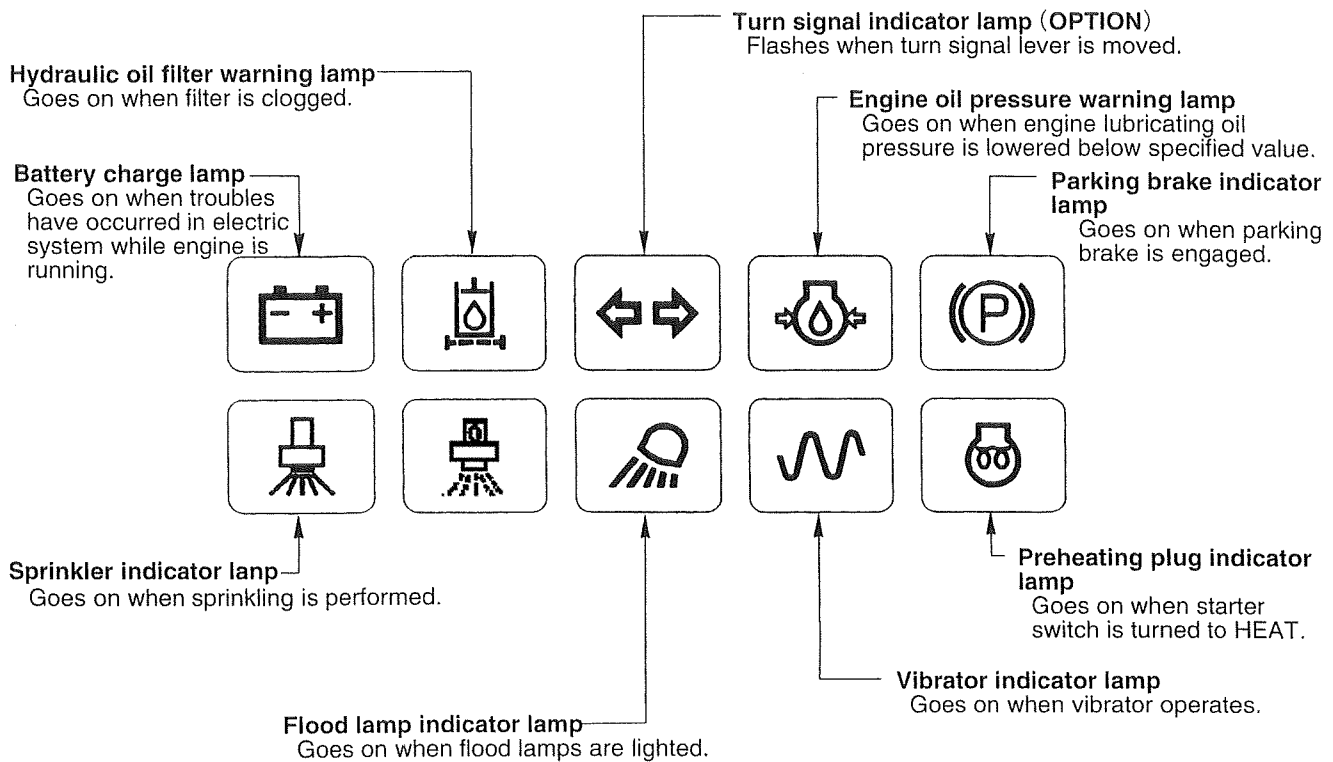

Fuel gauge

2. OPERATION

Monitor display



★ Indicator lamps [     ]
Light up when corresponding systems have been operated.

★ Warning lamps [  ]
Go on when the starter switch is turned to the ON position and go off when the engine has started. If any of them lights up while the engine is running, this indicates a faulty condition. Stop the engine and trace the source of trouble.

★ Bulb failure check
= Warning lamps and parking brake indicator lamp =
They should go on when the starter switch is turned to the ON position.
If not, corresponding bulb has burnt out.

CAUTION:

Hydraulic oil filter warning lamp may go on when the engine rpm is increased before the engine has been warmed up enough. Keep the engine idling until the lamp goes off, before starting your work.

2.1.3 Switches

Starter switch

Starts and stops the engine.

HEAT: When the engine is cold, hold the starter switch in the HEAT position, the heater indicator lamp will go on. Stay in that position until the indicator lamp goes off. Release the switch key when the indicator lamp goes off. The key will automatically return to the OFF position. Turn the key to the START position to start the engine.

OFF: The key can be removed in this position. All the electric systems are switched off. To shut down the engine, move the key to this position.

ON: The charging circuit and lamp circuit are charged with electricity. Let the key stay in this position after the engine has started.

START: The engine is cranked and gets started. The moment the engine has started, release the key. It will automatically return to the ON position.

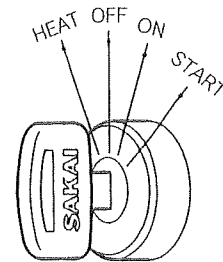

Lamp switch

Switches on and off the head lamps.

OFF: All lamps are switched off.

ON: Each gauge lamp and the headlamps become bright.

At this time, an icon  on monitor display will go on.

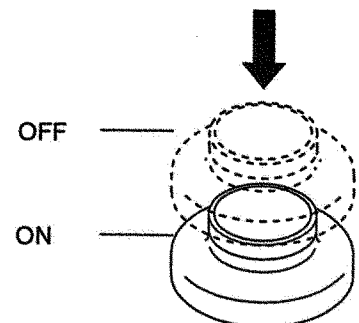

Turn signal lever (OPTION)

Turn signal lamp flashes when the turn signal lever is operated.

Left turn: Move the lever forward.

Right turn: Move the lever backward.

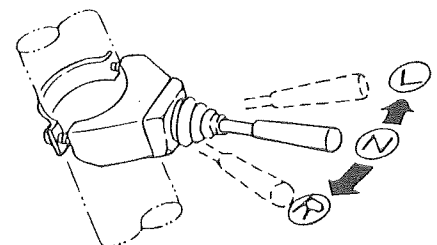

NOTE: The lever does not return to the OFF position even if the steering wheel is turned back.

2. OPERATION

Parking brake switch

If switch (P) is pressed down, the parking brake applies with the indicator lamp (P) on the monitor display lighted up.

When pressed again, the brake is released and the indicator lamp goes off.

⚠ WARNING

- To disengage the brake, be sure to press the button again instead of pulling it.
- When dismounting from the machine, press the button to apply the brake without fail.

⚠ CAUTION

- Never pull the switch UP. If the engine is shut down with the parking brake switch pushed down, the parking brake remains applied.

IMPORTANT

In an emergency, press the parking brake switch.

Horn switch

Pressing the button at the center of the steering wheel makes the horn sound.

Sprinkler switch

ON: Sprinkling is performed.

OFF: Sprinkling is shut off.

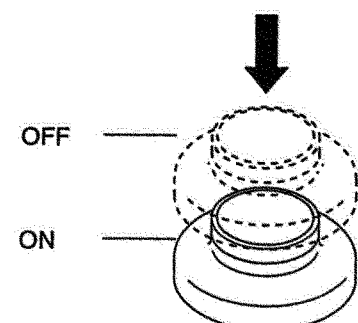
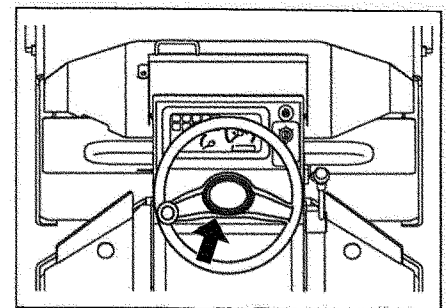
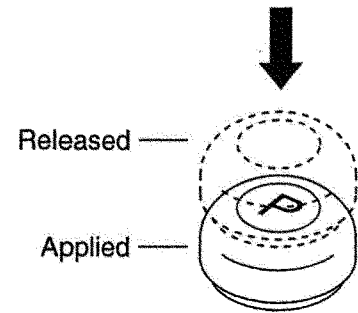

Liquid spray switch

Liquid is sprayed when switch  is pressed.
Spraying is shut off if the switch is released.

CAUTION

- Never pull the switch UP.
 - Driving the liquid spray pump with the liquid tank empty will damage the pump.
- Pay attention to the liquid level in the tank.

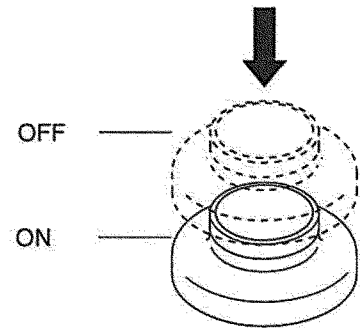

Vibrator switch

Selects two choices; CONT mode and AUTO mode.
Select either mode to meet the job requirements.

AUTO mode: Vibration is generated only when the machine is travelling. Vibration is shut down when the F-R lever is moved back to the neutral position.



mode: When this mode is selected, the vibrator goes into action. The vibrator continuous to work unless the engine is shut down or the vibrator switch is shifted to the OFF position.

○: Vibration is shut off.

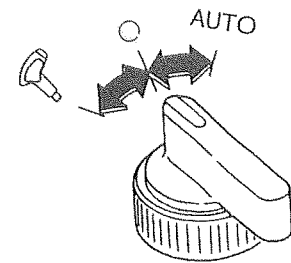

 position allows you to select the vibration with the switch provided on the F-R lever at left and right hand sides. Press either of them to work the vibrator.

Press again to shut off vibration.

Ensure that the vibration mode selector switch on the instrument panel is in the  position when operating the pushbutton switches.

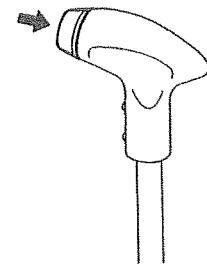

NOTE: For vibratory compaction, run the engine at 2,200 min⁻¹ (rpm) or higher.
Incline the throttle lever or forward / backward lever to adjust the vibration pressure transmission on slope so that the engine rpm may be 2200min⁻¹ (rpm) or more.

IMPORTANT

- Do not operate the vibrator on a hard area such as cement concrete pavement surface or the ground covered by thick steel sheets.
- Keep the vibrator stopped when the machine is at rest.
- Shut off the vibrator immediately when the machine has been caught in the mud during vibratory operation.

2. OPERATION

2.1.4 Operating levers/pedals

Forward-reverse lever (F-R lever) with vibrator switch

Moving the F-R lever forward or backward makes the machine travel forward or backward respectively. The neutral position brings the machine to a stop. The vehicle speed increases or decreases in proportion to the lever displacement.

The vibrator ON-OFF control is easily made by the F-R lever top vibrator switch (See page 23).

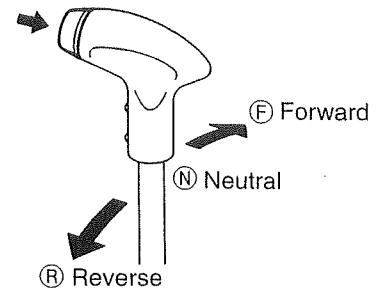

IMPORTANT

- For normal braking, return the F-R lever back to neutral.
- In an emergency, depress the brake pedal.
- This provides a quick braking with the F-R lever brought to the neutral position through a mechanical linkage.

Throttle lever

Shifts the engine RPM.

The engine RPM increases when moved toward the operator.

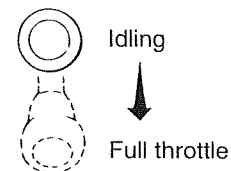

Unloading button (TWO)

The unloader lever disengages the drive, playing a role like a clutch. Use this lever for towing the machine when the engine is disabled or when troubles have developed in the hydraulic drive.

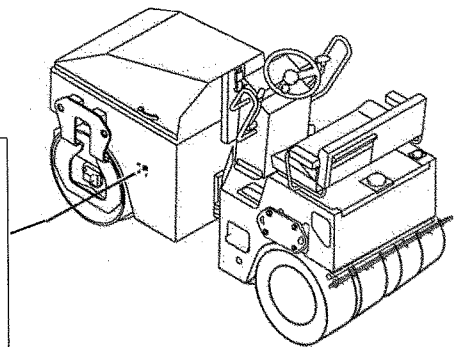
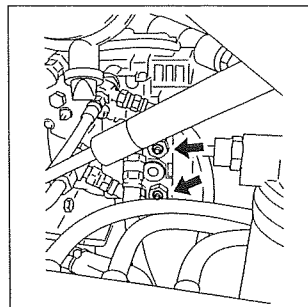

For Towing:

With engine turned off, press two buttons (Unload).

For normal travelling:

With engine turned on, it automatically resets.

⚠ WARNING

- On a slope, chock the wheels and use extreme care when handling the unloader button and towing the machine.
- When engine is turned on, unloader button automatically resets to be on-load.

NOTE: Be sure to operate the unloader button with the engine tuned off.

Brake pedal

In an emergency, push down on the pedal to the full extent, and the machine will come to a sudden stop.

IMPORTANT

Do not use the pedal wherever practicable except for an emergency. If used during the compacting operation of asphalt pavement, this can cause damage to its surface.

IMPORTANT

After depressing the pedal, return the F-R lever to the neutral position once, otherwise the vehicle will not move.

2.1.5 Fuse box

⚠ WARNING

When changing a fuse, cut the power supply by turning the starter switch to the OFF position.

Fuses protect electrical components and wiring from burning. Change any fuse which has become powder-coated due to deterioration or which has a play between it and fuse holder. To replace fuses, take off the cover. Be sure to use fuses of correct capacity.

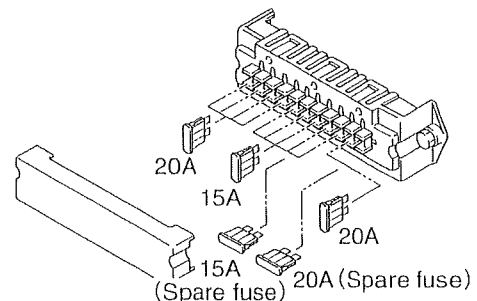

2.2 Handling and Adjustments

2.2.1 Seat adjustment

Adjust the seat for your best operating position. Move the lever as shown by arrow. With the lever held in that position, slide the seat forward or backward as desired. When properly adjusted, release the lever.

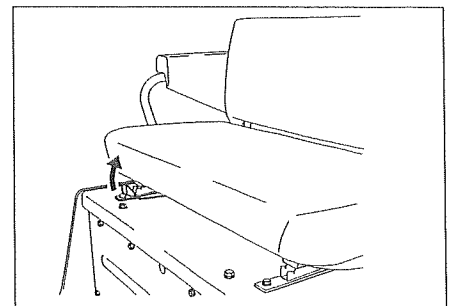

⚠ WARNING

The adjustment will be necessary when operating the machine first or when operators are alternated.

2. OPERATION

2.2.2 Scraper adjustment and replacement

Drum scraper

- 1) Clearance adjustment of scraper blades (a)
 - ① Loosen set bolts (b) at 2 locations.
 - ② Loosen bolts (c). Slide blade (a) until they make contact with the drum.
 - ③ For fine adjustment, turn bolts (c).
 - ④ When adjustment is complete, retighten bolts (b).
- 2) Replacement of scraper blades
 - ① Remove bolts (c).
 - ② Replace blades (a) with new ones.
 - ③ Refit and retighten bolts (c).

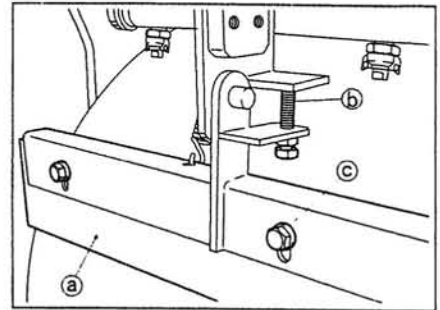

Tire scraper

- 1) Clearance adjustment of scraper (a)
 - ① Loosen set bolts (b) at 2 locations.
 - ② Loosen nuts (c) at 2 locations. Slide blades (a) until they make contact with the tire.
 - ③ Tighten nuts (c) at the position where the blade touches the tire.
 - ④ Adjust set bolt (b) to provide a clearance of 1mm (0.039in) between scraper blades (a) and tires.
- 2) Replacement of blades (a)
 - ① Remove nuts (c) and bolts (d) at 2 locations.
 - ② Replace blades (a) with new ones.
 - ③ Refit and retighten bolts (d).

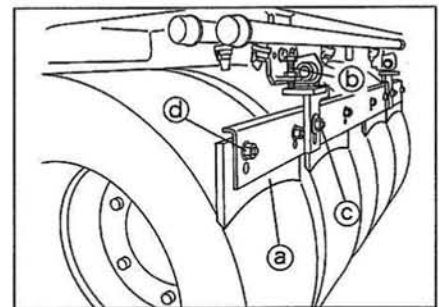

⚠ CAUTION

If the blade makes a close contact with the tire, the blade bites the tire in the rotating direction.

This can cause damage to the tire or blade. To avoid this, leave a clearance of about 1 mm.

NOTE: It is possible to raise the scraper so that it will not be in contact with the roll during operation.

⚠ WARNING

- Hold blade (a) and raise it slowly so that your hand will not be caught between the roll and blade.
- When returning raised (a) to the original position, exercise care so that your hand will not be caught between the roll and blade.

2. OPERATION

2.2.3 Disengaging the brake when towing

⚠ WARNING

On a slope, chock the drums and prepare for towing before disengaging the brake.

1) Front brake

- ① Remove the brake release bolts and washers (1 location) from the machine frame.
- ② Remove the plug of the hydraulic motor.
- ③ Put the bolt through the washer into the plug hole and tighten the bolt. The brake will be released when the bolt is tightened to a certain extent.
- ④ When towing is complete, set the bolts and washers in the original position and fit the plugs in the motors securely.

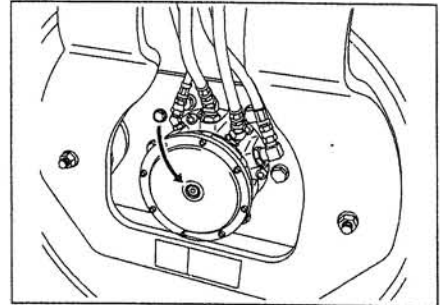

2) Rear brake

- ① Remove the protection cover of the hose for rear wheel.
- ② Remove the plug of the hydraulic motor.
- ③ Put the protective cover mounting bolt and washer into the plug hole and tighten the bolt. The brake will be released when the bolt is tightened to a certain extent.
- ④ After traction, attach the bolt and washer back to the original position, and tighten the plug to attach it completely to the motor.

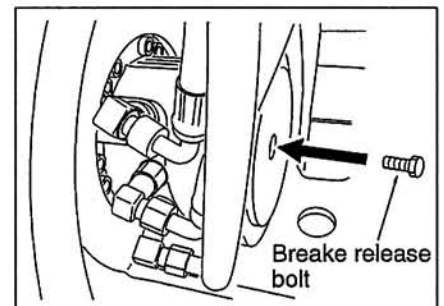
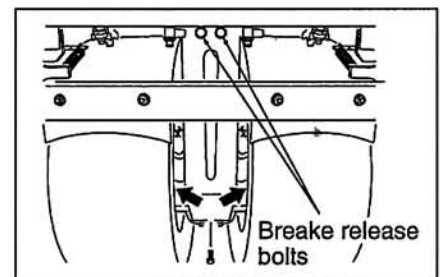

⚠ WARNING

- Do not try to release the brake immediately after a hot engine has been stopped. Let the oil cool down.
- For the brake disengagement, wear hard hat and safety goggles.

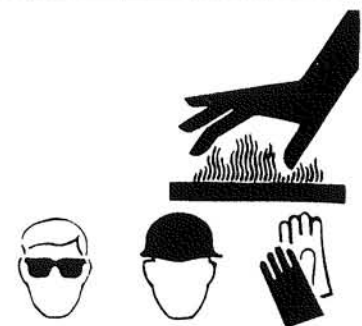

NOTE: Perform the work rapidly, as the oil will gush out as the plugs are taken off. Wash clean the brake release bolts and blank plugs before fitting to the motors.

2.3 Operation

⚠ WARNING

- This machine is a one-man roller.
- Operate the machine from the operator's seat.

2.3.1 Before-starting inspection

- 1) Check that the steering lock pin is in the carrying position.

⚠ WARNING

Make sure that the steering lock pin is connected in the carrying position before putting the machine in motion. Steering is impossible if the pin is in the steering lock position.

NOTE: Removed lock pin should be installed to the round pipe at front right of the rear frame.

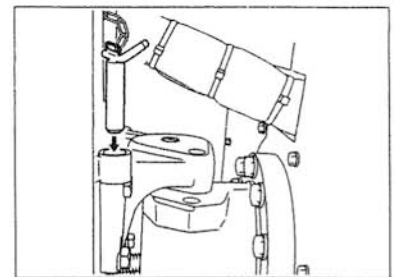
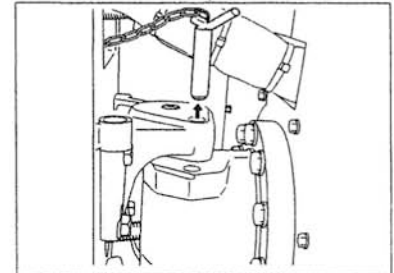
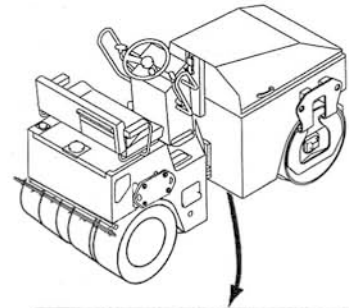

- 2) Check that the F-R lever is in the neutral position (N).

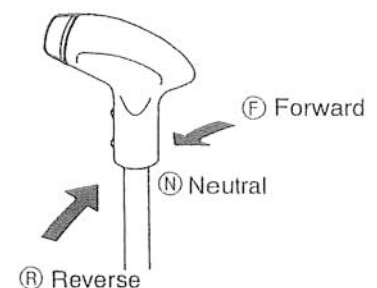

NOTE: The engine does not start due to an interlocking system if the F-R lever is not in the neutral position. Ensure that the F-R lever is in the neutral position (N) before starting.

2. OPERATION

2.3.2 Starting the engine

⚠ WARNING

- Check that the F-R lever is in the neutral position, and sound the horn when starting the engine after making certain that there are no one and no objects close to the machine.
- Make sure that vibrator switch has been turned off.

1) Set the throttle lever in a position slightly higher than IDLING.

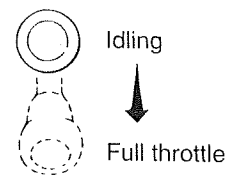

2) Turn the starter switch to the ON position and check that the warning lamps and parking brake indicator lamp on the monitor display are on.

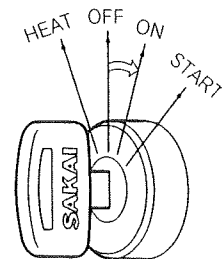
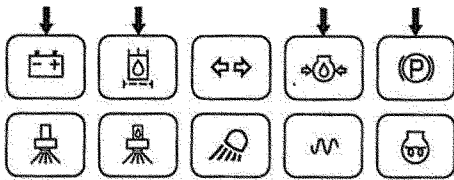

3) In cold weather, hold the starter switch in the HEAT position until the heater indicator lamp goes on. Let the switch key to stay in this position till the indicator lamp goes off. Now the engine is ready to start.

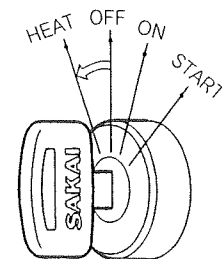

- 4) Turning the key to the START position makes the engine start. Release the key the moment the engine has started. The key will automatically return to the ON position.

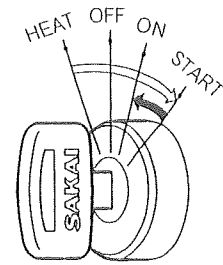

⚠ CAUTION

- Do not allow the starter key to stay in the START position for more than 15 seconds.
- If the engine does not start, allow an interval before trying again.
- Check that the warning lamps on the monitor display go off immediately after the engine is started. If any of these warning lamps becomes bright while the engine is running, shut down the machine, determine the cause and rectify the fault.

2.3.3 After starting the engine

Try not to move to operation immediately after starting but observe the following:

IMPORTANT

Avoid increasing the engine speed abruptly before warming-up run is completed.

- ① Run the engine at around 1,200 min⁻¹ (rpm) for about 5 minutes to warm it up. Warming-up run allows the lubricating oil to reach the vital parts of the engine and hydraulic system, while gradually bringing up the engine oil and hydraulic oil to the working temperature.
- ② After the warm-up operation, check that:
 - Temperature gaugePointer falls near the center zone.
 - Fuel gaugePointer falls between the E and F marks
 - Charge lampHas gone off.
 - Engine oil pressure warning lamp.....Has gone off.
- ③ Check for the color of exhaust gas, listen for unusual sounds and vibration. If abnormal, determine the cause and correct the problem.

2. OPERATION

2.3.4 Traveling

⚠ CAUTION

While travelling, do not turn the starter switch OFF.

⚠ WARNING

When starting, operate the horn after securing the safety around the machine. Clear away obstacles on the road.

1) Lower the throttle lever to increase engine rpm.

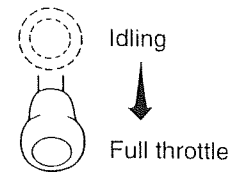

2) Press down the parking brake switch to release the brake. Check that indicator lamp  on the monitor display goes off.

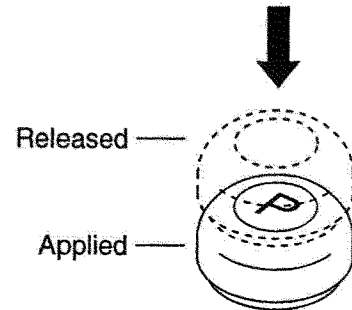

3) Move the F-R lever in the direction to travel, and the machine will begin traveling.

⚠ CAUTION

Avoid abrupt operation of the F-R lever.

NOTE: The travel speed can be controlled by the throttle lever and F-R lever.

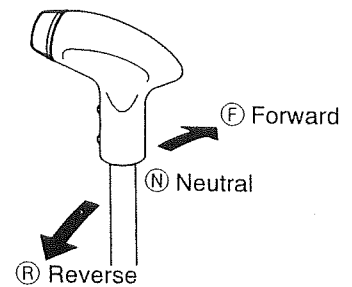

⚠ WARNING

Pay extreme attention to the area behind the machine when backing, since the space just behind it tends to be a blind spot.

2.3.5 Stopping / Parking

⚠ WARNING

- Avoid abrupt braking. Try to leave enough time for braking.
- Avoid parking on a grade.
- If necessary to park on a grade wheel to prevent unexpected moving down the grade.

1) Bring the F-R lever to the neutral position (N), and the machine will come to a halt.

⚠ CAUTION

- For normal braking, move the F-R lever back to the neutral position. In an emergency, depress the brake pedal.

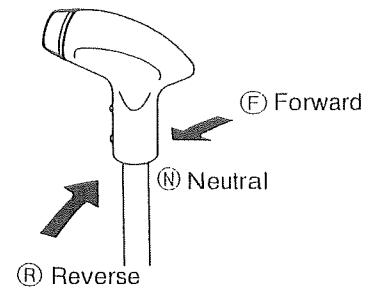

2) Press the parking switch securely, and check that indicator lamp  illuminates.

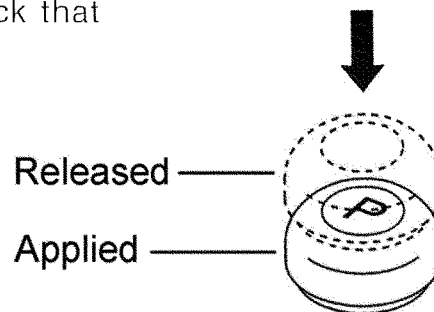

2. OPERATION

2.3.6 Stopping the Engine

1) Gradually cool down the engine at low idling for about 5 minutes.

IMPORTANT

- Do not bring a hot engine to a sudden stop except for an emergency. This will shorten the life of its component parts.
- Do not also allow an overheated engine to come to a sudden stop, but run it at middle idling speed for gradual cooling down.

2) Turn the starter key to the OFF position to stop the engine.

⚠ CAUTION

Do not turn the starter switch OFF while the machine is in motion.

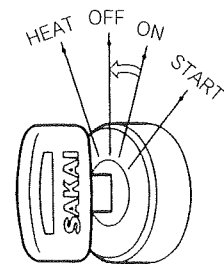

3) Remove the starter key.

⚠ WARNING

- When dismounting from the machine, apply the brake by pressing the parking switch button. If necessary to park on a grade, block the wheels to prevent unexpected moving down the grade. Never fail to remove the starter key.

2.3.7 Check after Stopping the Engine

- 1) Perform the walk-around checks for oil and water leakage, abnormal signs around the drums.
- 2) Fill the fuel tank.
- 3) Remove waste paper if any from the engine compartment, as this will pose a possible fire hazard.
- 4) Scrape mud or other materials from and around the drums. For transportation, obey traffic regulations.

2.4 Vibratory Operation

1) Run the engine at 2,200min⁻¹ (rpm) or higher by operating the throttle lever.

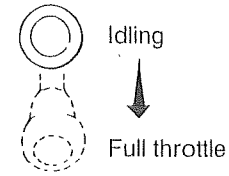

2) Select AUTO mode or CONT mode depending upon job requirements.

Vibrator switch

Selects two choices; CONT mode and AUTO mode. Select either mode to meet the job requirements.

AUTO mode: Vibration is generated only when the machine is travelling. Vibration is shut down when the F-R lever is moved back to the neutral position.



mode: When this mode is selected, the vibrator goes into action. The vibrator continuous to work unless the engine is shut down or the vibrator switch is shifted to the OFF position.

O : Vibration is shut off.

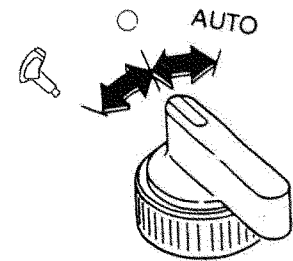

Placing  position allows you to select the vibration with the switch provided on the F-R lever at left and right hand sides. Press either of them to work the vibrator.

Press again to shut off vibration.

Ensure that the vibration mode selector switch on the instrument panel is in the  position when operating the pushbutton switches.

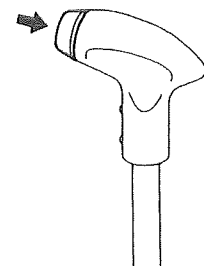

3) Proper travel speed for vibratory compaction is 2 ~ 6 km/h (1.2mile / h ~ 3.7mile / h), however, select speeds depending upon job requirements.

⚠ CAUTION

- Keep the vibrator shut off when the machine is not rolling.
- Stop vibration if the machine has encountered a running difficulty, for example, when it gets stuck in the mud.

2. OPERATION

2.5 Sprinkler

- 1) Before sprinkling, check for the water level in the sprinkler tank with the sight gauge. Add water as necessary.

IMPORTANT

Use clean water wherever practicable.

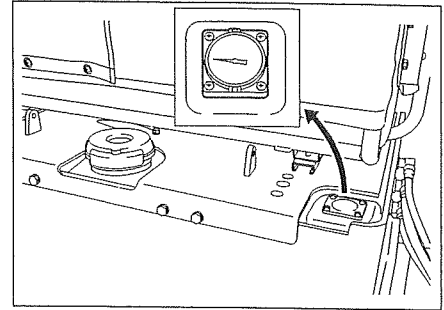

- 2) Turn the sprinkler switch to the ON position. Sprinkling will be performed. To shut off sprinkling, set the switch to the OFF position.

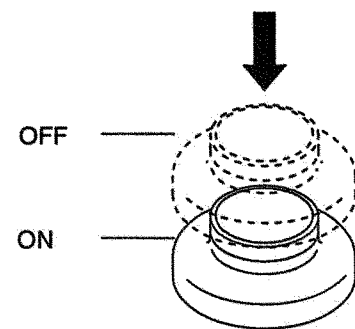

CAUTION

- Pay attention to the water level in the sprinkler tank. If the pump operates with the tank empty, this will cause a pump failure.
- To avoid freezing, fully drain the sprinkler tank, pump, sprinkler bars, filter and sprinkler piping in cold weather.

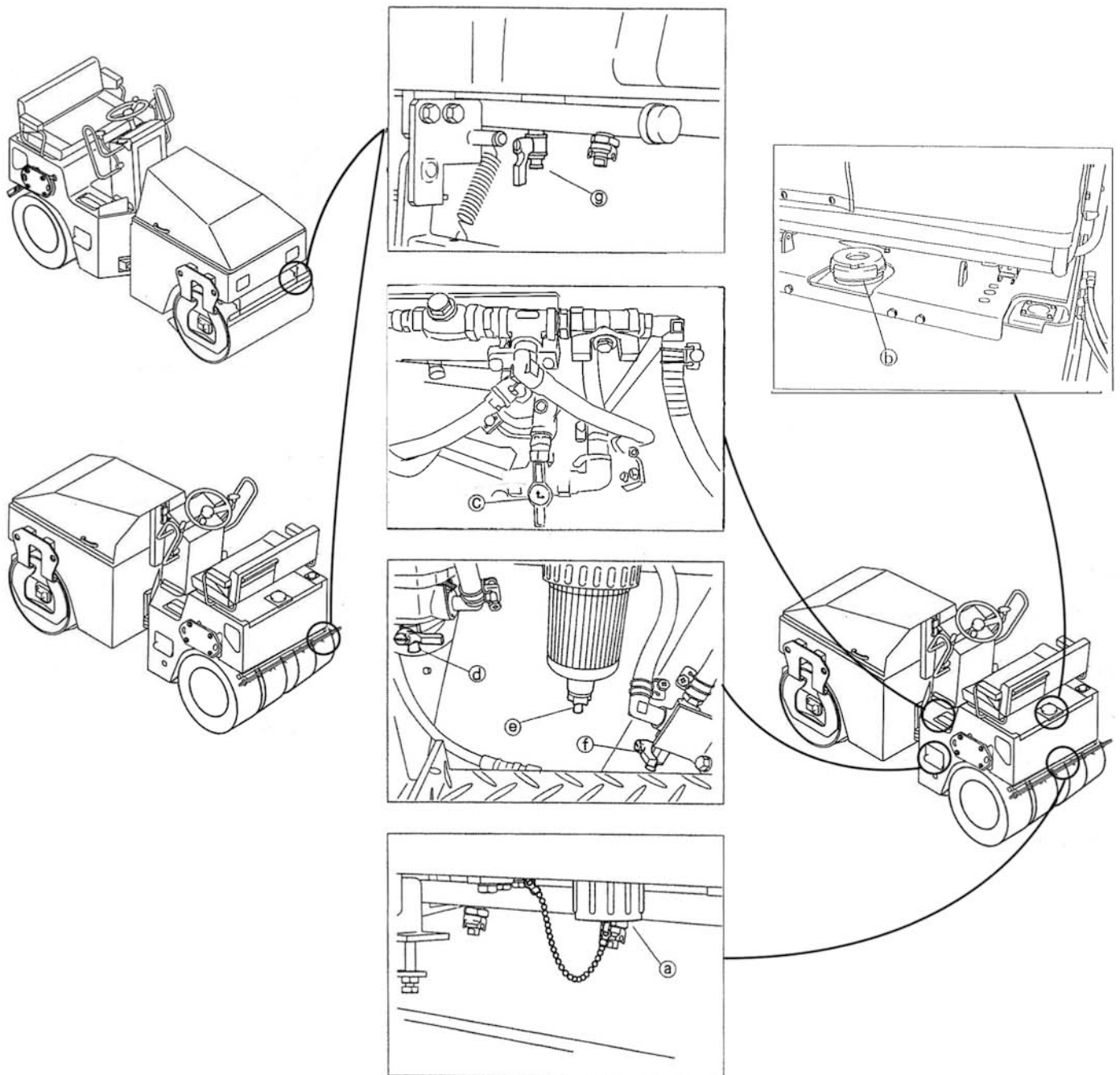

To drain water:

- ① Remove sprinker tank drain cap ① and water filler cap ② to completely drain the tank.
- ② Open sprinkler tank selector valve ③ fully. Drain water completely by opening sprinkler pump drain valve ④, sprinkler filter drain valve ⑤ and drain cocks ⑥.
- ③ Drain the front and rear sprinkler bars by opening valve ⑦.
- ④ Allow the sprinkler pump to run dry for 5 to 10 seconds with the pump drain valve open to drain the pump completely.
- ⑤ Also drain the hoses, pump and sprinkler nozzles.

2. OPERATION

Water may not come out of the sprinkler nozzle when an attempt is made to spray water again after draining the water according to the procedure shown on p.37 in that case, operate the machine according to the procedure shown below.

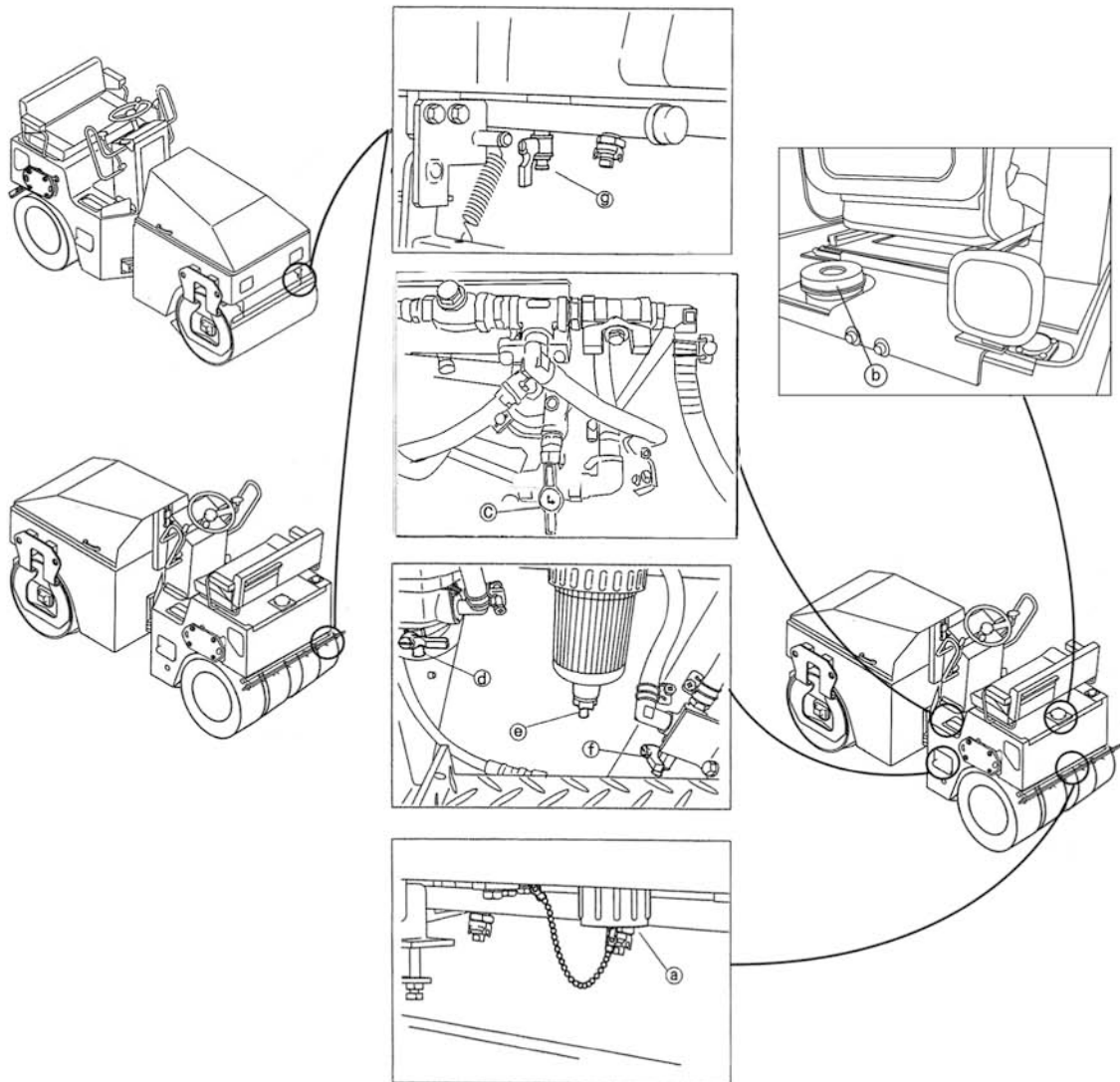

Supplementary explanation of air-bleeding

- (1) Check that all caps and valves (a), (c) - (g) are closed.
- (2) Start the sprinkler pump.
- (3) Repeat open-close operation of air bleeder valve (d) to remove air from the pipeline.
(Water will be discharged simultaneously.)
- (4) After confirmation of complete removal of air, close air bleeder valve (d).

IMPORTANT

When the sprinkler filter was blurred, air-bleeding may not be able to do.
In that case, clean the sprinkler filter.

2.6 Liquid Sprayer

- 1) Before spraying, check for the liquid level in the tank.
Add liquid as necessary.
Look at the tank under the right side of the driver seat to check the liquid level.

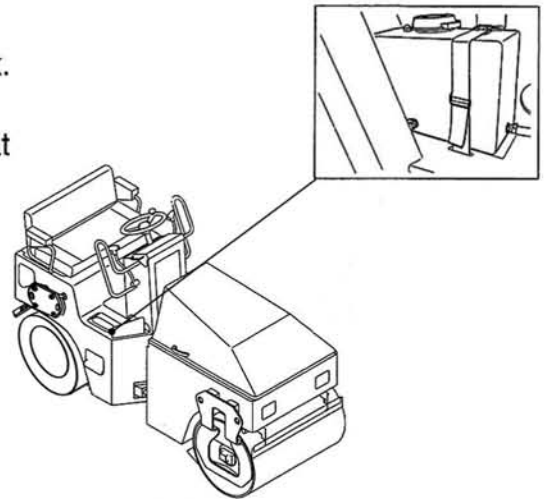

- 2) The liquid is sprayed over the tires. To spray, press the liquid spray switch. Spraying is shut off when the switch is released. A valve is located on the liquid spray pipe to adjust spraying. To increase spraying, turn the knob clockwise. For reduced spray, rotate it counterclockwise.

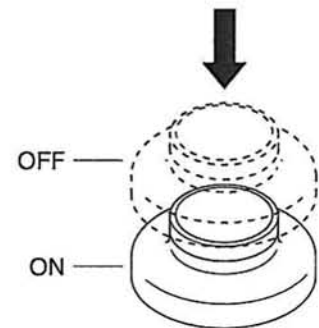

Adjustment of nozzle extension width

When spraying the tires with liquid, adjust the nozzle extension width so that the liquid will not be sprayed beyond the tire.

Operate the liquid spray quantity control valve on the liquid pipes of the front and rear tires to adjust the nozzle extension width.

Turn the valve counterclockwise.

... The nozzle extension width will increase.
(The spraying quantity increases.)

Turn the valve clockwise.

... The nozzle extension width will decrease.
(The spraying quantity decreases.)

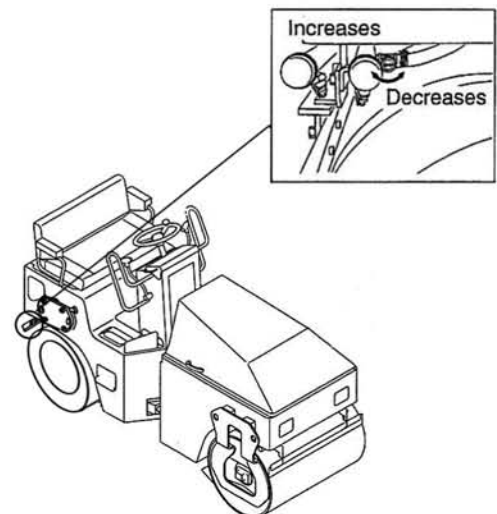

⚠ CAUTION

- For spraying, use the smallest amount possible. Excessive spraying can cause premature wear of tires, their deformation and adverse effect on the pavement surface.
- Driving the liquid spray pump with the liquid tank empty will damage the pump. Pay attention to the liquid level in the tank.
- For a long storage of the machine, drain the liquid through the drain hole.

2. OPERATION

2.7 Precautions for Work

2.7.1 Compaction operation

■ **Do not operate the vibrator on hard location**

- Do not work the vibrator on a hard surface such as concrete pavement, as this can cause the machine to jump and give abnormal shock load. Damage to shock isolators will result.

■ **Change the direction of travel gently.**

- When changing the direction of travel during asphalt mix compaction, slowly shift the F-R lever.

2.7.2 When going downhill

■ **Use the F-R lever.**

- Run slowly by the operation of the F-R lever even if the travel distance is short.

■ **Use the engine brake**

- Go downhill by applying the engine brake along with the F-R lever operation.

⚠ DANGER !

Travel downhill with the F-R levers half tilted (half stroke) using caution not to allow the engine to exceed $1,800\text{min}^{-1}$ (rpm).

2.7.3 On a slope

■ **Working on a sidehill**

- Work in an uphill/downhill direction, and avoid working on sidehill with the machine inclining sideways.

2.8 Applicable Jobs

The machines do a variety of jobs as listed below:.

Work

- Asphalt road paving
- Dust removal treatment for road
- Road improvement
- Embankment construction
- Dam construction
- Construction of forestry and farm roads
- Foundation building
- Construction of sidewalk, shoulder and gutter foundation

Material to be compacted

- | | |
|--------------------|-------------|
| • Asphalt pavement | • Soils |
| • Crusher run | • Slag |
| • Cement concrete | • Soft rock |
| • Sands | |

Layers to be compacted

- | | |
|---------------------------------|--------------|
| • Surface course, Binder course | • Embankment |
| • Base course | • Shoulder |
| • Subgrade | • Sidewalk |

2.9 After Operation

Follow the procedures below to prevent the machine from falling into an unworkable condition the following morning caused by muds and other extraneous matter on the drum, or frozen drums:

- 1) Remove muds and water from the machine. Muds can get into the seals together with water drops on the hydraulic cylinder piston rod. Damaged seals will result.
- 2) Park the machine on a hard and dry surface. If such a place is not available, cover the ground with hard plates.
- 3) Low temperature will cause a significant reduction of battery efficiency. Cover batteries or take them off from the machine and store in a warm place for the following day's operation.
- 4) To avoid freezing, fully drain the sprinkler tank, pipes and filter in cold weather.

See " To drain water "on page 36.

IMPORTANT

- **Insufficient draining can cause damages to the system or create other troubles.**
- **Do not wash clean with high pressure water around the instrument panel or reverse side of the dash board. This can instrument failures.**

2. OPERATION

2.10 Loading and Unloading

⚠ WARNING

- Use sturdy ramps with proper width, length and thickness which allow safe loading and unloading.
- If the ramps deflect considerably under load, apply wooden blocks to reinforce them.
- Loading should be conducted on a level and hard ground. Leave a sufficient distance between the machine and the shoulder.
- To prevent slippage on the ramps, keep the drums free from mud, oils, etc. The ramps must also be free of grease, oil and ice.
- Do not steer the machine on the ramps. If the machine is facing in the wrong direction, allow it to dismount from the ramps and correct the direction.

For loading and unloading, use ramps or a proper loading stand.

2.10.1 Use of a trailer equipped with a winch

⚠ WARNING

Unloading by pressing unload button causes the power to be disconnected. Therefore, never attempt to place your body in front or back of the machine.

1) Engage the trailer brake and chock its wheels. Fix the ramps so that the machine and trailer are completely aligned.

☆ The angle between the ramps and ground must be less than 15 degrees.

☆ Leave a proper space between the ramps according to the width of the roller drum.

2) Decide the correct direction of run and make the machine run forward to the ramps.

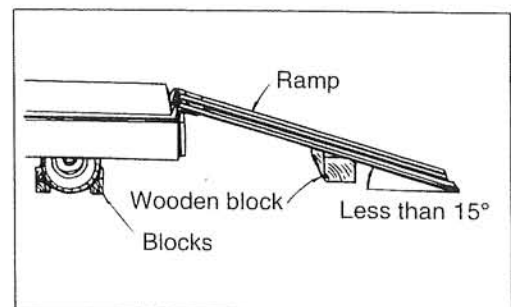

- 3) Draw the wire rope from the trailer winch and put its hook on the hooking point ① or ② of the roller.
- 4) With the starter switch placed at OFF position, disengage the brake manually. (See page 27)
- 5) Unload button is located in engine room. Press the unload button to unload. (See page 24)
- 6) Use the winch of truck for loading and unloading.

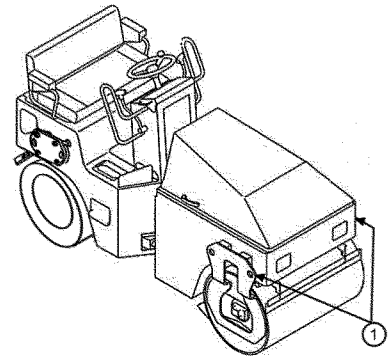

- 7) After loading or unloading, return the brake, which has been disengaged, to original to original position and start the engine once. Unload button will reset automatically.

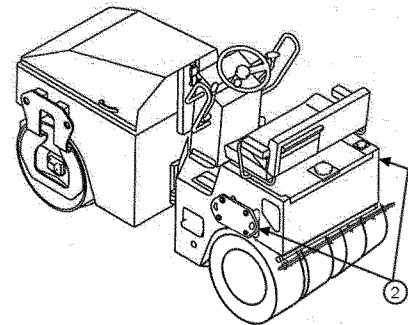

- 8) Locate the machine correctly on the trailer.

2.10.2 Self-propelling

- 1) Engage the trailer brake and chock its wheels. Fix the ramps so that the machine and trailer are completely aligned.

☆ The angle between the ramps and ground must be less than 15 degrees.

☆ Leave a proper space between the ramps according to the width of the roller drum.

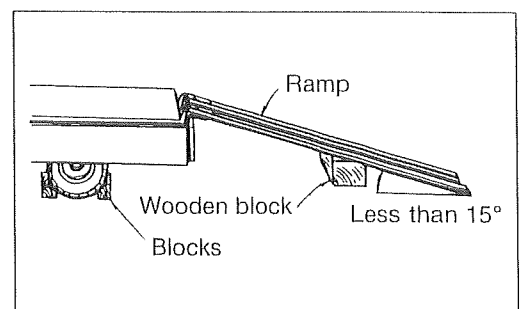

- 2) Decide the correct direction of run and conduct loading or unloading at low speed.

For loading, run forward at low speed.
For unloading, run backward at low speed.

- 3) Locate the machine correctly on the trailer.

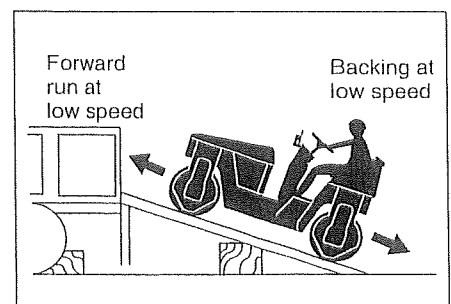

2. OPERATION

2.10.3 Use of a hoist

⚠ WARNING

- When lifting, use sturdy wire ropes.
- Before lifting, lock articulation by means of lock far located by the center pin.

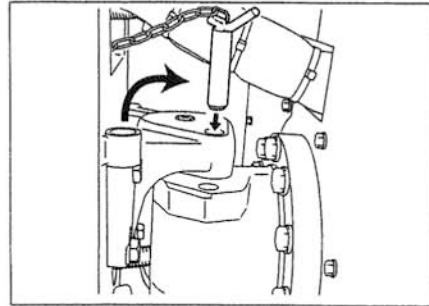

⚠ CAUTION

To do the lifting and lowering work, fold the awning.

- 1) Apply parking brake of the trailer and chock its wheels to prevent unexpected movement.
- 2) Put wire ropes securely on the hook and lifting points as shown.
- 3) If wire ropes make contact with other parts of the machine, put pieces of cloth or wooden blocks at the contact points. Carefully perform lifting.
- 4) When lifting, keep the machine properly ballanced.
- 5) Locate the machine correctly on the trailer.

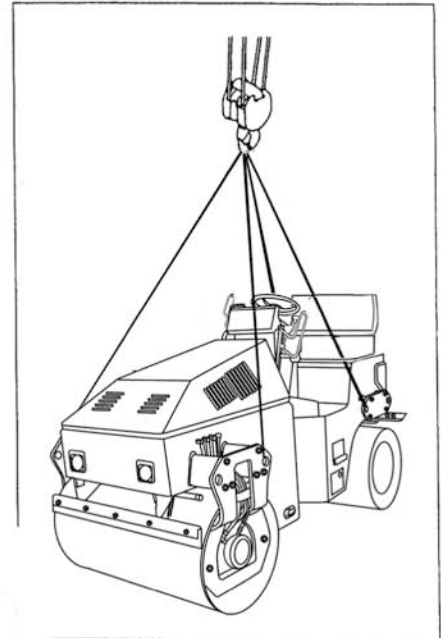

2.11 After Loading the Machine

When the machine has been located properly on the trailer, tie it down as follows:

- 1) Press the parking switch button to apply the parking brake. Place wooden blocks under the drums to prevent movement.
- 2) Fix the machine with ropes tied at the front and rear towing hook holes. Particularly, pay attention to sidewise skidding.

2.12 Transportation

⚠ WARNING

To decide the transporting route, check the width of the road, height and weight (including the roller) of the trailer. Obey relevant regulations.

2.13 Operation in Cold Weather

In cold weather, take the following measures to prevent troubles such as starting difficulty and coolant freeze-up.

2.13.1 Fuel oil and grease

Use fuel and oil with low viscosity. See "Rating" on page 77.

2. OPERATION

2.13.2 Coolant

⚠ WARNING

Do not bring an open flame to the antifreeze or do not smoke when handling it. It is inflammable.

⚠ CAUTION

NEVER use methanol-, ethanol- and propanol-base antifreeze.

Use soft water for coolant.

In freezing weather, add antifreeze to the coolant referring to the table below. Select the most suitable mix ratio according the lowest temperature in the job location.

	(gal.)				
Ambient temperature	-33°C (-27.4°F)	-26°C (-14.8°F)	-20°C (-4°F)	-16°C (3.2°F)	-11°C (12.2°F)
Amount of anti-freeze	3.45L (0.9)	3.1L (0.8)	2.8L (0.7)	2.4L (0.6)	2L (0.5)
Amount of coolant	3.45L (0.9)	3.8L (1.0)	4.1L (1.1)	4.5L (1.2)	4.9L (1.3)
Ratio	50%	45%	40%	35%	30%

The rollers use a long-life coolant (35% solution). Change the coolant at lease every two years.

Use non-amine type long-life coolant when changing coolant.

IMPORTANT

Use of machine with a rich coolant in summer time can overheat the engine depending job conditions. Use a coolant of 30% solution in the hot season.

2.13.3 Battery

⚠ WARNING

- Batteries generate explosive gases. Do not use an open flame close to batteries.
- The battery electrolyte is corrosive. Keep the electrolyte away from your eyes and skin. If you are affected by the electrolyte, flush with large quantities of water and get medical help.

When the temperature decreases, the battery capacity will lower, possibly freezing the electrolyte.

Keep the battery in a satisfactory condition at all times, and pay attention to heat insulation for satisfactory start-up on the next morning.

The hydrometer atop the battery permits confirmation of the condition of the battery.

Green	Satisfactory
Black	Charging is necessary.
Semitransparent	Replacement is necessary.

2.14 When the Cold Season is Over

When winter is over and the warm season has come, proceed as follows:

- 1) Change oil and fuel with those for use in warm season referring to "Rating" on page 79.
- 2) If AF-PT antifreeze is in use, drain the coolant completely, wash clean inside the cooling system, and then fill with clean water (city water).

2. OPERATION

2.15 For a Long Storage Period

For leaving the machine unused for longer than one month, proceed as follows:

- 1) Store the machine in a closed area after cleaning.
- 2) Conduct oiling, greasing and changing of oil.
- 3) Grease lubricate the exposed portion of hydraulic cylinder piston rods.
- 4) Cover the battery after disconnecting the negative cable or take off the battery from the machine and store in a safe place.
- 5) If the temperature is expected to go down below 0°C, add antifreeze to the coolant.
- 6) Completely drain the sprinkler water.
- 7) Place the F-R lever in the neutral position (N), turn the vibrator and sprinkler switches off and apply the parking brake.
- 8) Chock the machine.
- 9) Remove the starter switch key.

2.16 During the Storage Period

⚠ WARNING

If necessary to operate the machine for anti-corrosive purpose in closed area, ensure good ventilation keeping windows and doors open to prevent gas poisoning.

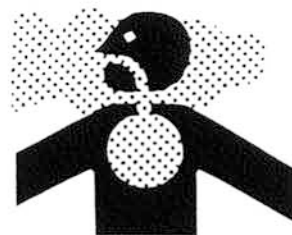

- During storage, operate the machine at least once a month to prevent the oil films on the lubricated parts from deteriorating and to charge the batteries.

2.17 When the Battery Has Discharged

⚠ WARNING

- To check and handle the batteries, keep the engine stopped with the starter switch in the OFF position.
- The batteries give off explosive gases. Do not smoke close to the batteries. Keep flames and sparks away from the batteries.
- The electrolyte is very corrosive and will harm your clothing or skin. If the electrolyte has come into contact with your clothing or skin, flush with sufficient amount of water. In case the electrolyte has gotten into your eyes, flush with water and get medical help.
- To disconnect the battery cables, start with the negative terminal (earth). When connecting, start with the positive terminal. Do not allow a metallic item to bridge between the positive terminal and machine body. This can generate sparks, causing an explosion.
- Loose battery terminals can cause sparks. An explosion will result. When connecting the terminals, make certain that they are tight.

Disconnect with negative cable first

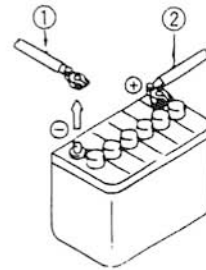

Connect with positive cable first

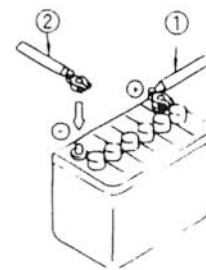

2. OPERATION

2.17.1 Connection and disconnection of booster cables

When jump-starting the engine, connect the booster cables as follows:

■ Connection of booster cables

- 1) Connect one end of the positive booster cable (A) to the positive (+) terminal of the battery on the machine.
- 2) Connect the other end of the positive booster cable to the positive (+) terminal of the booster supply.
- 3) Connect the negative booster cable (B) to the negative (-) terminal of the booster supply.
- 4) Connect the other end of the negative booster cable to a good earth of the engine block of the machine.

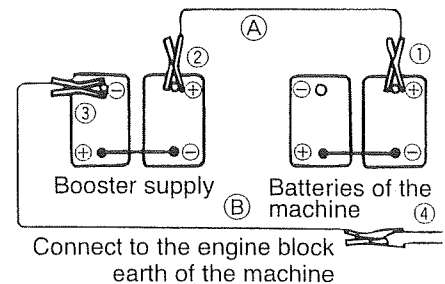

■ Disconnection of booster cables

- 1) Disconnect the negative booster cable (B) from the engine block earth.
- 2) Disconnect the negative booster cable (B) from the booster supply.
- 3) Disconnect the positive booster cable (A) from the booster supply.
- 4) Disconnect the positive booster cable (A) from the machine.

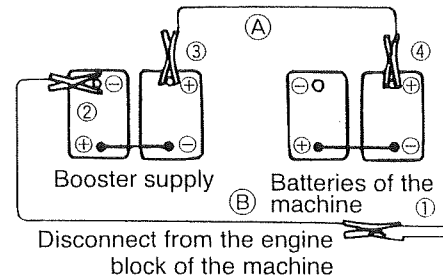

⚠ WARNING

- Do not allow the positive (+) terminal to make contact with the negative (-) terminal when connecting the booster cables.
- Wear safety goggles when jump-starting the engine.
- Do not allow the machine to make careless contact with the booster supply.
- Do not make wrong connections. Connect the negative (-) cable to the engine block earth far away from the battery, as sparks may occur when connecting.

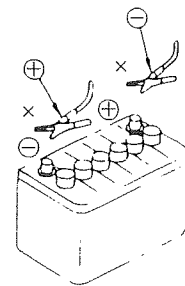

⚠ CAUTION

- Use booster cables and end clips of proper size suited to the battery capacity.
- Use the batteries of the equal capacity for the machine and booster supply.
- Check booster cables and end clips for signs of damage and corrosion.
- Connect the clips positively.

3. PERIODICAL MAINTENANCE

3.1 Precautions

Whether or not the inspection service and lubrication are performed at the correct regular intervals exerts significant influence on the occurrence of trouble and service life of the machine. In this manual, typical intervals for inspection and service are given. However, flexibility should be introduced as to interval or type of services to enable your machine to always operate in the best condition.

General Precautions:

- 1) Always use Sakai genuine parts for replacement.
- 2) Use lubricants recommended by Sakai. Avoid mixing different brand lubricants.
- 3) For hydraulic oil replenishment, changing, level checking, filter cleaning or replacement, oiling and greasing, use extreme care to prevent dust from entering.
- 4) For checking oil level or changing oil, park the machine on a level and hard surface.
- 5) Change oil while its temperature remains high after operation.
- 6) For a long-term storage, fill the fuel tank, lubricate necessary points and run the machine for more than 20 minutes once a month.
- 7) In freezing weather, add antifreeze to the coolant according to the ambient temperature.
- 8) For the hydraulic pump and motor, have them serviced at authorized service shops.
- 9) Turn the starter switch OFF when performing services such as repairing broken wires, short circuits and tightening loose terminals.

Periodical Replacement of Essential Maintenance Parts

In order secure safety for work and travel, conduct inspection and services.

Further, for enhanced safety, following parts and components should be replaced periodically.

These parts are prone to material deterioration due to aging or physical change due to friction, while it is difficult to determine their useful limit by regular inspection, which makes it necessary to replace with new ones after certain period of service to maintain their perfect function.

If any abnormality is detected such as crack, deformation or oil leakage, go ahead and replace them even if it is within scheduled replacement time.

3. PERIODICAL MAINTENANCE

System or Mechanism	Part name	Periodical replacement maintenance parts	Replacement period	Remarks
1. Brake system	Master cylinder	Seals (rubber parts)	2 years	Adopted machines only
	Wheel cylinder	Seals (rubber parts)	2 years	∕
	Brake piping parts	Brake hose	2 years	
		Air hose	2 years	Adopted machines only
Operating parts	Cable	4 years	∕	
2. Steering system	Orbitrol	Seals (rubber parts)	2 years	
	Hydraulic piping parts	Hydraulic hose	2 years	
	Steering cylinder	Seals (rubber parts)	2 years	
	Hydraulic pump	Seals (rubber parts)	4 years	
3. Power transmission system (inclusive of axle)	Axle	Seals (rubber parts)	4 years	Adopted machines only
	Travel pump	Seals (rubber parts)	4 years	∕
	Travel motor	Seals (rubber parts)	4 years	∕
	Hydraulic piping parts	Hydraulic hose	4 years	∕
	Isolation rubber	Isolation rubber itself	4 years	∕
4. Fuel system	Piping parts	Fuel hose	4 years	
5. Engine related	Engine mounting parts	Isolation rubber	4 years	
	Seals (rubber parts)	Packing and others	4 years	
	Drive parts	V-belt	2 years	
6. Cooling system	Piping parts	Radiator hose	2 years	
7. Control related parts	Cable	Cable	4 years	Adopted machines only

⚠ CAUTION

- With a new machine, change the engine oil and change the engine oil filter elements after 50 hours of operation for the first time only.
- When trouble occurs in the location indicated by the indicator lamp on the monitor display, sensor will work and corresponding lamp comes on. If this occurs, conduct necessary service regardless of the periodical service interval recommendation.
- Check the electric wiring at a regular interval not exceeding one month:
 - 1) Damage to the wire harness and loose clamps
 - 2) Loose sockets
 - 3) Function of electrical systems

3.2 Walk-around Checking

For efficient operation, daily, before-operation checking is very important. Before starting, perform walk-around checking for loose bolts, nuts and signs of leakage in addition to items as shown below:

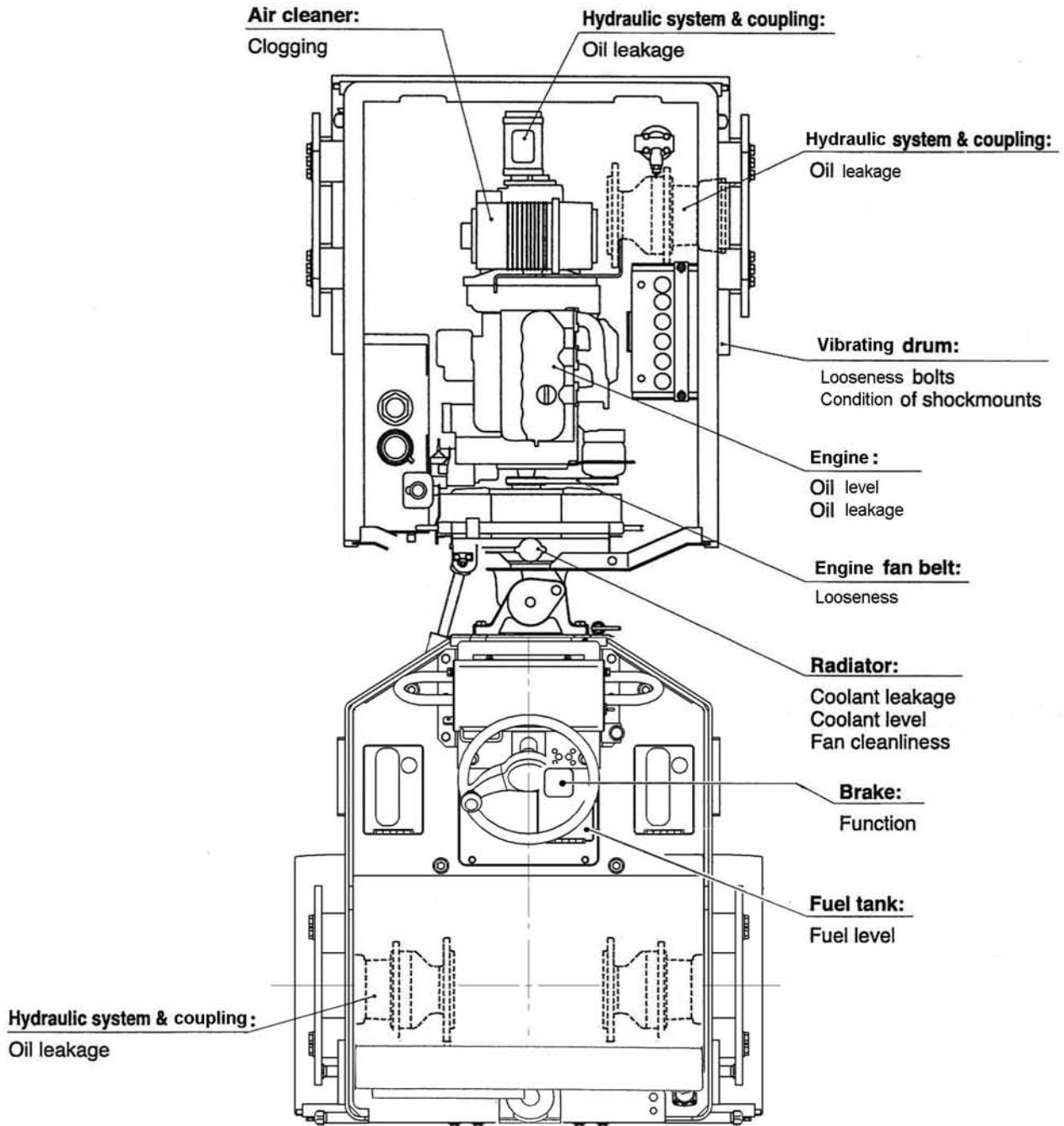

3. PERIODICAL MAINTENANCE

3.3 Periodical Maintenance Points

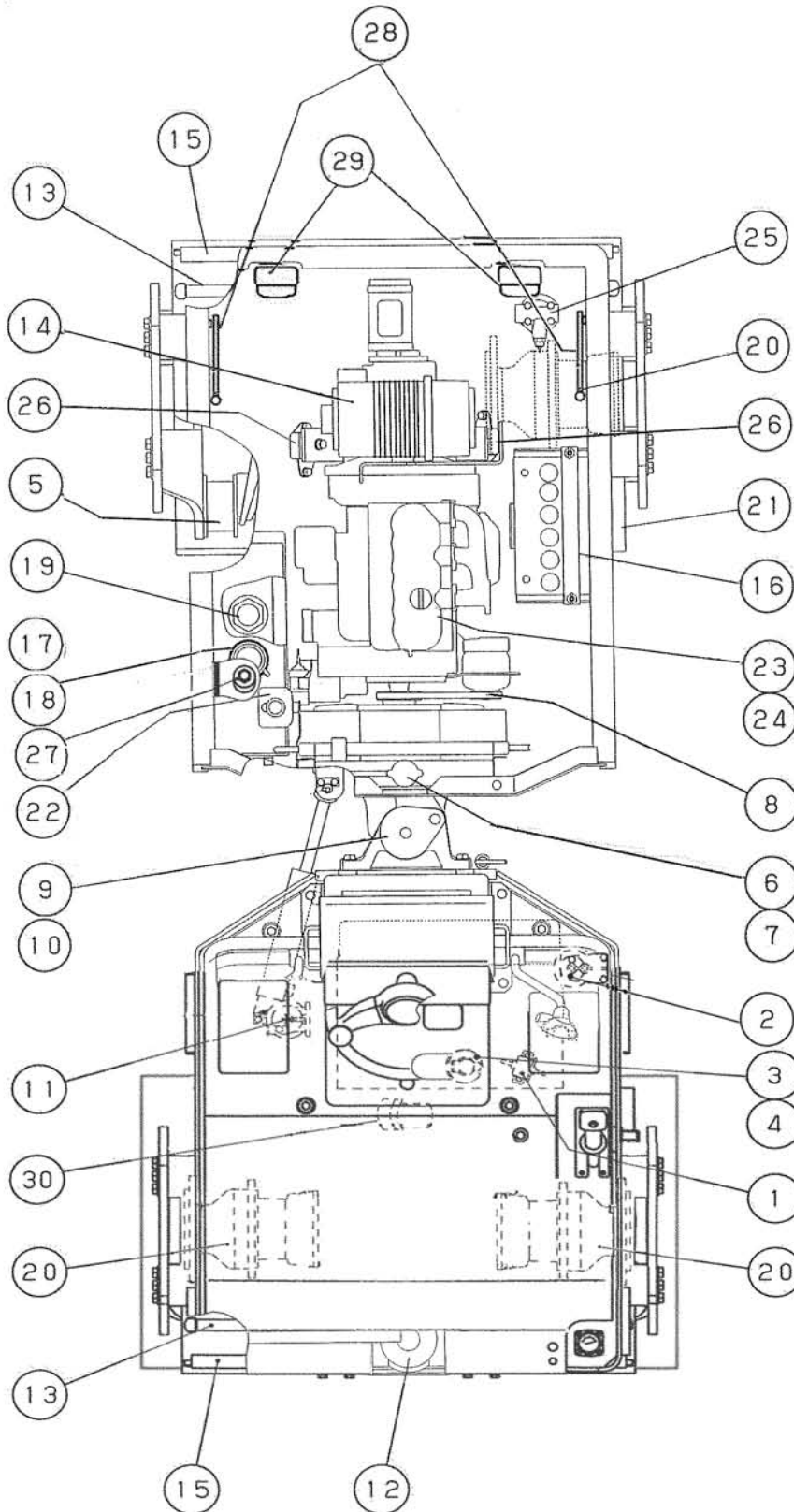

3. PERIODICAL MAINTENANCE

Interval	Ref. No.	Item	Service	Lubricant	Q'ty
Every 10 hours or daily	③	Fuel tank	Check fuel level, add as necessary	Diesel oil	1
	⑥	Radiator	Check coolant level, add as necessary	Coolant	1
	⑧	Fan belt	Check looseness, adjust as necessary		1
	⑯	Battery	Check fluid level	Battery fluid	1
	⑰	Hydraulic tank	Check oil level, add as necessary	Hydraulic oil	1
	⑳	Engine oil pan	Check oil level, add as necessary	Engine oil	1
	㉓	Tires	Check for the inflation	Pressure & Injury check	4
Every 100 hours	⑨	Cylinder pin	Apply grease	Grease	2
Every 200 hours	㉒	Engine oil filter	Replace element		1
	㉔	Engine oil pan	Change oil	Engien oil	1
Every 250 hours	⑳	Wheel hub nut	Check looseness		24
Every 450 hours	②	Fuel filter	Replace element		1
Every 500 hours	①	Fuel pump	Clean filter		1
	②	Fuel filter	Replace element		1
	⑦	Radiator	Clean fins		1
	⑩	Tilt pin	Apply grease	Grease	2
	⑱	Hydraulic tank	Change element, wash inside	Hydraulic oil	1
	⑲	Suction filter	Clean or replace element		1
	㉕	Line filter	Replace element		1
	㉗	Suction filter	Clean or replace element		1
Every 1000 hours	㉚	Wheel motor	Brake maintenance or change		3
	㉛	Vibrator	Change oil	Gear oil	1
	㉞	Shockmounts (Engine mount)	Check cracks		4

3. PERIODICAL MAINTENANCE

Interval	Ref. No.	Item	Service	Lubricant	Q'ty
As required	④	Fuel tank	Clean inside		1
	⑤	Shockmounts (Roll mount)	Check cracks		—
	⑪	Sprinkler filter	Clean element or replace		1
	⑫	Sprinkler tank	Clean inside		1
	⑬	Sprinkler & liquid spray pipe, nozzle	Clean or replace		—
	⑭	Air cleaner	Clean element or replace		1
	⑮	Scraper	Adjust or replace blade		—
	⑳	Hood shocks	Clean movement or chang		2
	㉑	Electric bulbs	Blowout check		2
	⑳	Liquid spray filter	Clean or replace element		1

3. PERIODICAL MAINTENANCE

3.4 Maintenance Procedure

➔ For servicing the engine, see the separate engine manual.

(1) Every 10 hours or daily

③ Fuel tank

Check the fuel level with the fuel gauge or the level gauge. Add as necessary from fill hole.

To open the filler cap, insert the starter key.

NOTE: Never refuel with the strainer removed.

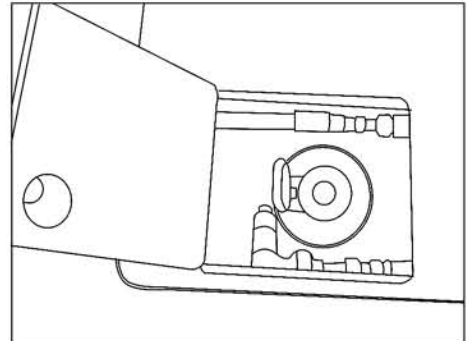

⚠ CAUTION
For refueling, park the machine on a level and solid surface.

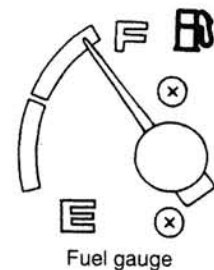

⑥ Radiator

With the cap removed, check to see if the coolant level is near the port. Add as necessary.

Use soft water for coolant.

Check to see if the coolant lever in the reserve bottle is between low and high marks immediately after running the engine at idling for 2 to 3 minutes.

If the level is lower than specified, add the coolant to the reserve bottle.

For the coolant, use soft water.

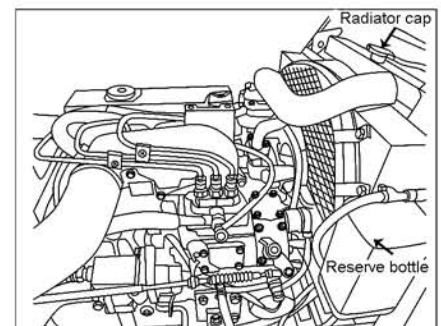

⚠ WARNING
Do not remove the radiator cap while the coolant is hot.



⑧ Fan belt

- 1) Check the fan belt for wear and damage. Replace as necessary.
- 2) Check the tension. Depress the middle of belt with a push of about 10kg. A properly adjusted belt deflects about 10mm.
- 3) To adjust, loosen alternator bracket bolt (A) and plate bolt (B), and slide the alternator.

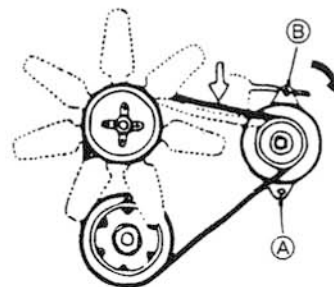

⑩ Battery

- 1) The color of the indicator at upper part of the battery indicates the state of the battery.
- 2) Retighten any loose terminal. Apply grease or vaseline to the terminals to retard rusting.

⑪ Hydraulic tank

Check the oil level with the sight glass on the side of tank. The level is proper if it is between H and L marks. If necessary, add the hydraulic fluid from the fill port.

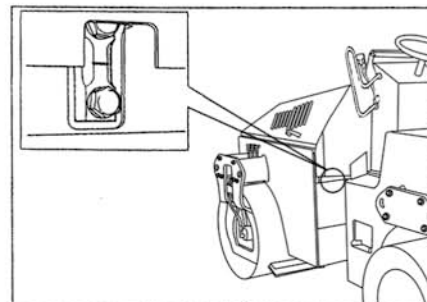

⑬ Engine oil pan

Shut down the engine and check the engine oil level. If it is not between MAX and MIN marks, add oil through the fill hole.

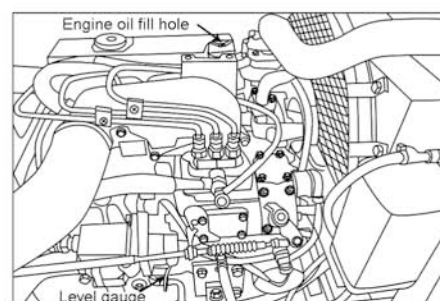

⑳ Tires

- 1) Check for unusual wear and damage.
- 2) Check for the inflation pressure.
294 kPa (3.0 kgf/cm²)
- 3) Check the wheel nuts for looseness.

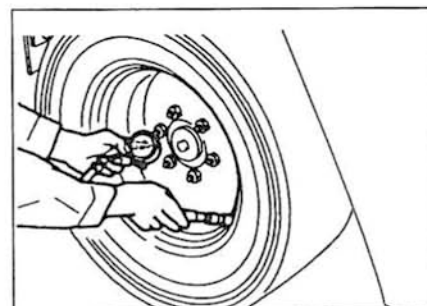

3. PERIODICAL MAINTENANCE

(2) Every 100 hours

⑨ Cylinder pin

Grease the fittings ① at two locations.

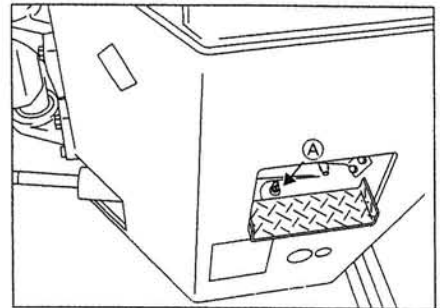
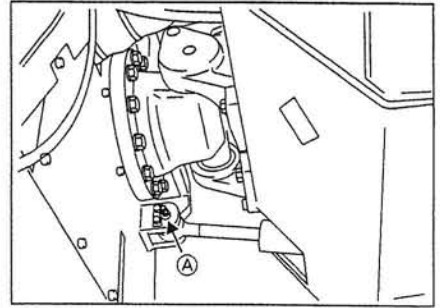

(3) Every 200 hours

⑳ Engine oil filter

㉔ Engine oil pan

➔ See the separate engine manual.

- 1) After completion of operation and while the oil is warm, drain the oil with the drain plug removed.

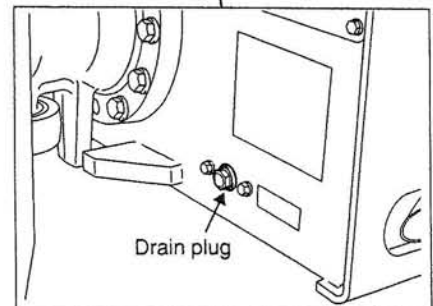
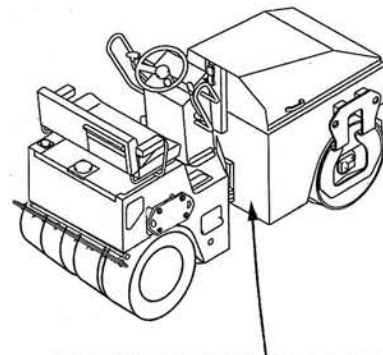

⚠ WARNING

When draining a hot oil, use care not to get burned.

2) Refit the drain plug and fill the crankcase with the engine oil from the fill hole on the cylinder head cover.

3) Change the oil filter.

NOTE: For a new machine, change oil filter element at 50 operating hours for the initial time only.

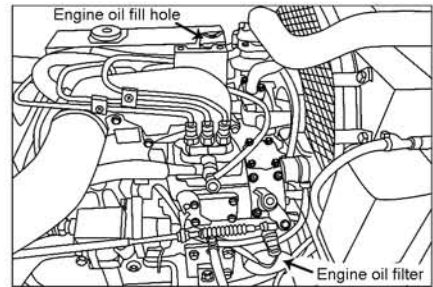

(4) Every 250 hours

31 Wheel hub nut

Check the wheel hub nut for looseness. If it is loose, tighten it. Be sure to torque it to the specified value.

Tightening torque: 186 N · m

⚠ CAUTION

- Turn the wheel hub nut in the tightening direction during inspection.
- Excessive tightening of the wheel hub nut will lead to breakage of bolts or cracks in the disc wheel. Be sure to observe the specified torque.

NOTE: Tighten the wheel hub nut 50 hours after purchase of a new vehicle or replacement of tires.

(5) Every 450 hours

2 Fuel filter

➔ See the separate engine manual.

Change the filter cartridge.

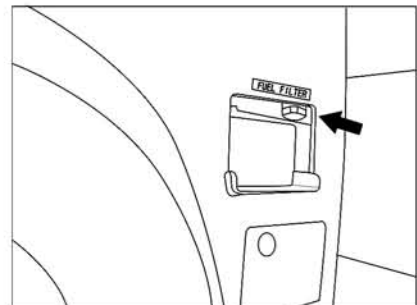

(6) Every 500 hours

1 Fuel pump

➔ See the separate engine manual.

Clean the filter

2 Fuel filter

➔ See the separate engine manual.

Change the filter cartridge.

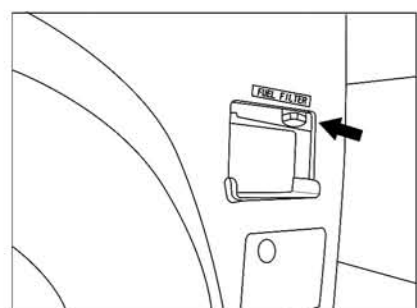

3. PERIODICAL MAINTENANCE

⑦ Radiator

Clean the cooling fins.

⑩ Tilt pin

Grease the fittings ⑧.

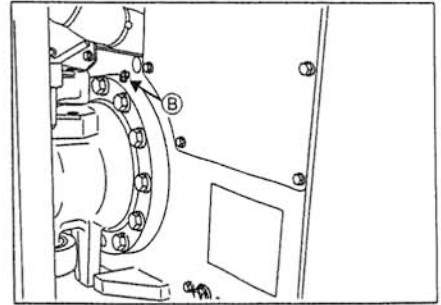

⑱ Hydraulic tank

- 1) Remove the drain plug, and drain oil while it is warm.
- 2) Clean inside of the tank, and fill fresh oil to the specified level.
- 3) Start and run the engine at idling for 2 to 5 minutes. When the hydraulic oil has become free from air bubbles, stop the engine and recheck the oil level.

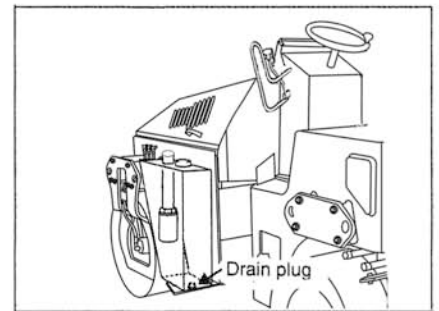

⑲ Suction filter

Take off the hydraulic tank cover. Take out and clean the strainer, change the strainer if necessary.

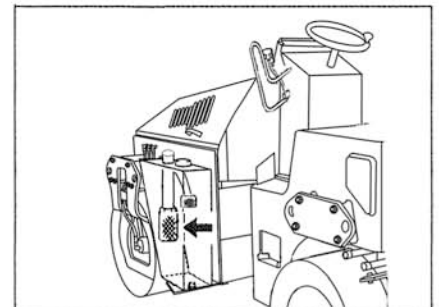

⑳ Line filter

Remove the filter case by turning counter-clockwise as viewed from the bottom, and change the element.

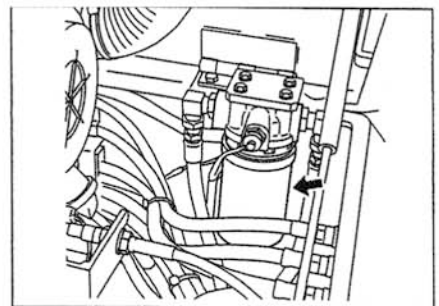

㉑ Suction filter

Take off the hydraulic tank cover. Take out and clean the strainer, change the strainer if necessary.

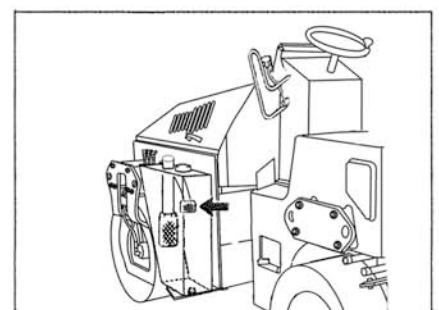

(7) Every 1,000 hours

20 Wheel motor

Replacement procedure

① Disassembling

1) Brake cover

Loosen 8 × hex. socket bolts (D42) which is fixing the brake cover (D02). Be sure to loosen them uniformly, because brake spring (D11) tends to push up the cover (D02).

	DCM0280
Bolt size	M6 × 20L
Distance across hex. socket	5mm

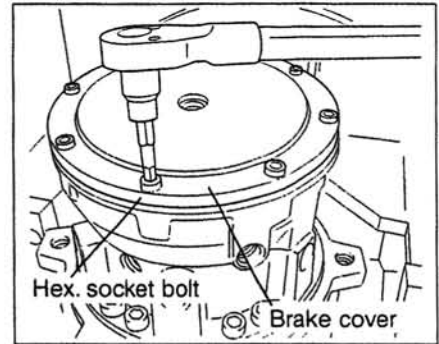

CAUTION

Unless bolts are loosened uniformly, the last bolt to be loosened can be broken.

2) Brake spring

Taking off the brake cover (D02) causes the brake spring (D11) to appear, which is to be removed.

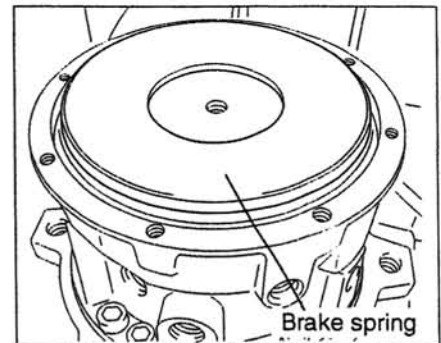

3) Preparation for brake piston removal

After removing the O-ring (D53) and hex. socket plugs (D63), (D64) with O-ring for the forced brake releasing port from the brake cover(D02), place the brake cover over the brake housing.

In order to prevent pressure from building up during this removal, be sure to have the brake release pilot port opened.

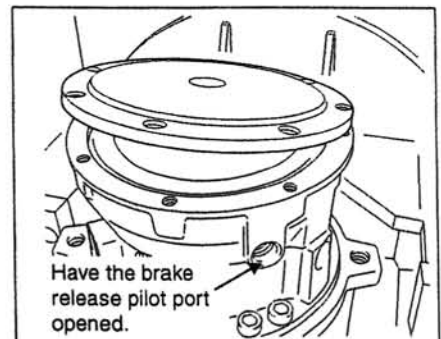

3. PERIODICAL MAINTENANCE

4) Brake piston

Turning-in the hex. socket bolts for forced brake releasing port, causes brake piston (D03) to be lifted up.

【Bolt and washer for forced break releasing】

	DCM0280
Bolt (Pitch)	M10×25L (1.5)
High strength washer OD Thickness	For M10 19 ~ 23 2.5 ~ 3.5

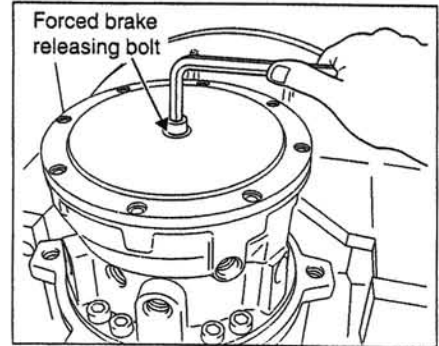

CAUTION

For protection of O-ring, be sure to use washer.

5) Brake piston removal

When bolts are completely tightened, loosen it once again and insert a block between the brake housing and brake cover (D02) to lift the brake piston (D03) further.

Repeat adding the block to increase thickness until the brake piston (D03) becomes removable.

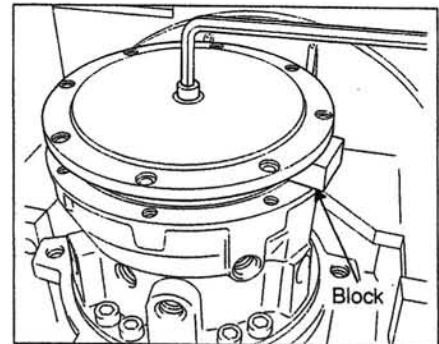

6) Brake disk

Take out brake shim (D14), separate plate (D13) and friction plate (D12). For easy removal, use a piece of wire which is bent at its end.

Removing 4 or 5 of separate plates (D13) and friction plates (D12) respectively, will allow you to remove brake shaft (D04). Take out all of the separate plates (D13) and friction plates (D12).

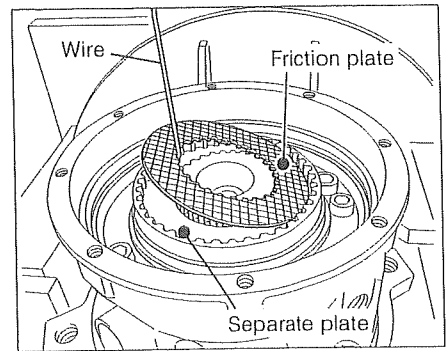

Item	Quantity
Brake shim	A / R
Separate plate	15
Friction plate	14

CAUTION

Use care not lose steel ball and brake shaft spring.

② Reassembly

1) Brake disk

Install brake shaft (D04).

Install separate plate (D13) and friction plate (D12) alternately. Use care to keep proper quantity and order of installation.

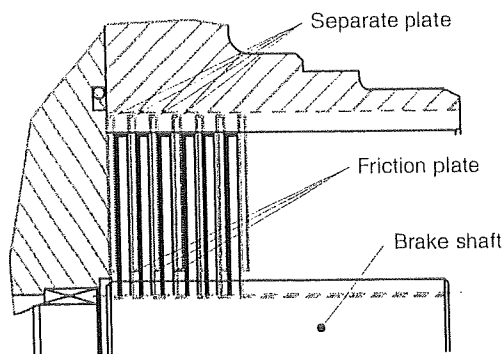
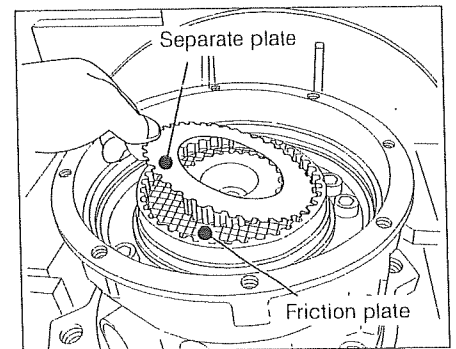

CAUTION

Install the brake shaft all the way to the back end. Installing the brake plate with the brake shaft remaining at halfway, may cause friction plate falling off the spline.

<Proper condition>

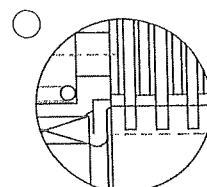

<Fallen off the spline>

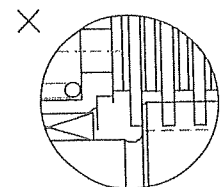

3. PERIODICAL MAINTENANCE

2) Brake shim

After completing the installation of separate plate (D13) and friction plate (D12), install brake shim (D14). In principle, use the same shims (D14) which were in use before disassembling. However, if the brake piston (D03) stroke has exceeded the specified range (See “Inspection after replacement” later herein), it is necessary to add or remove shim (D14).

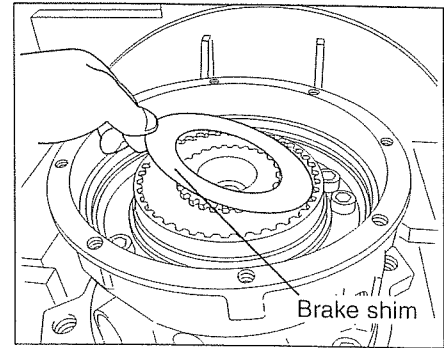

【Break down of the brake shim package】

	DCM0280
Dwg. No.	1745162 - S
Shim thickness	0.8 × 1
	0.4 × 1
	0.2 × 1
	0.1 × 1

The “Brake shim package” shipped for service use, contains number of shims shown in this chart above.

3) Steel ball

Install brake shaft spring (D21) and steel ball (D22).
 When assembling with cam motor positioned horizontally (brake installed from side), apply grease which is on the harder side to the periphery to prevent steel ball (D22) from falling off.

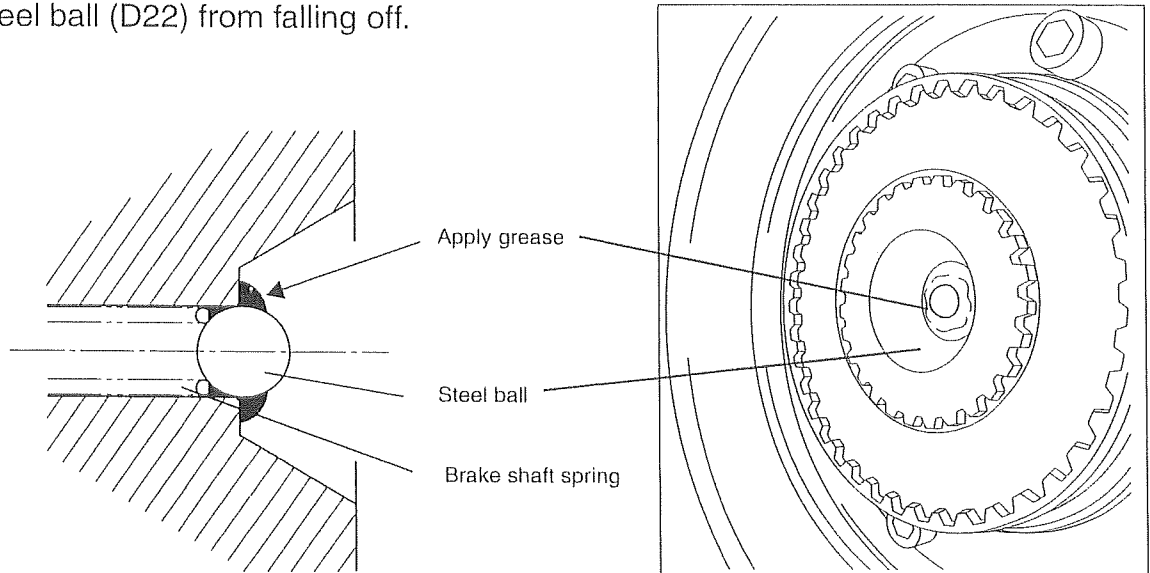

CAUTION

When assembling with cam motor positioned horizontally, make sure that the brake shaft has positively reached all the way to the back.
 The depth from the face of brake housing spline to the brake shaft is proper if it falls within the range shown below:

	DCM0280
"L" in the sketch to the right.	1.2 ~ 2.8mm

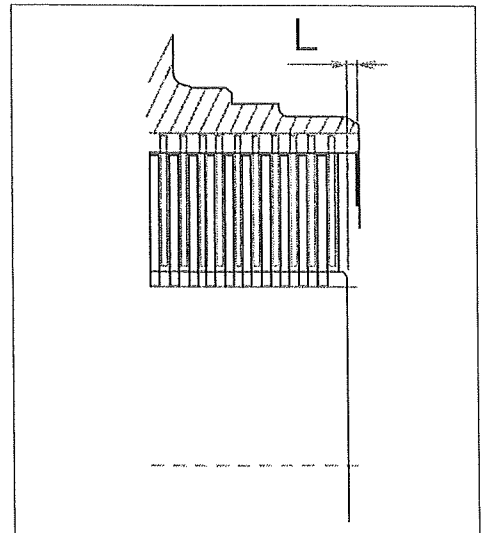

3. PERIODICAL MAINTENANCE

4) Brake piston

Install O-ring, small (D51) and O-ring, large (D52) to the brake spring (D03) respectively.

Install brake piston (D03) to brake housing.

Push it in all the way, while tapping lightly on it with plastic hammer.

⚠ CAUTION

Coat the O-rings with mineral oil gel and use care to avoid incurring scar or any other damage.

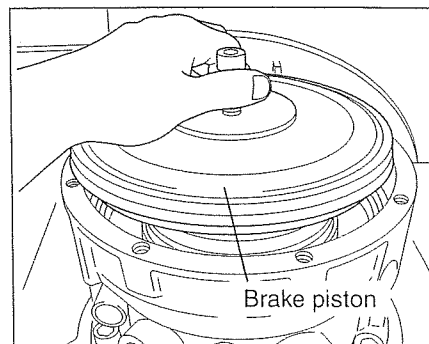

5) Brake spring

Place brake spring (D11) on brake piston (D03) and cover them with brake cover (D02) to which O-ring (D53) has been installed.

⚠ CAUTION

Coat the O-rings with mineral oil gel and use care to avoid incurring scar or any other damage.

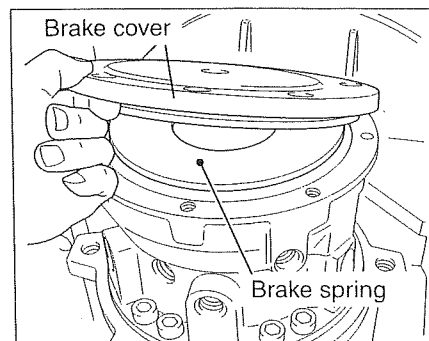

6) Brake cover

Tighten the brake cover (D02) with hex. socket bolts (D42). Tighten 8 bolts uniformly.

⚠ CAUTION

Unless bolts are tightened uniformly, the bolt tightened first can be broken.

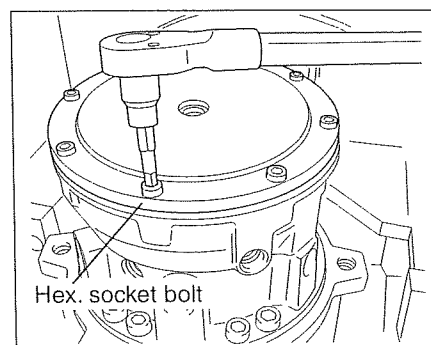

【Hex. socket bolt tightening torque】

	DCM0280
Bolt size	M6 × 20L
Tightening torque	14 ~ 17N-m

3. PERIODICAL MAINTENANCE

③ Checking after the replacement (Measuring the brake piston stroke)

The check value specified in this paragraph is for new brake disk immediately after having been installed for replacement. Please note that it is different from “Replacement Standard” in the next paragraph which represents the case where the brake has been in use.

1) Forced releasing bolt

Install hex. socket bolt for forced brake releasing. Do not tighten the bolt all the way, but leave it floating off the seat thereof.

	DCM0280
Bolt (Pitch)	M10×25L (1.5)

With the brake releasing pilot port opened to atmosphere (brake being locked), measure the height of bolt head from brake cover by means of depth slide calipers. <L1>

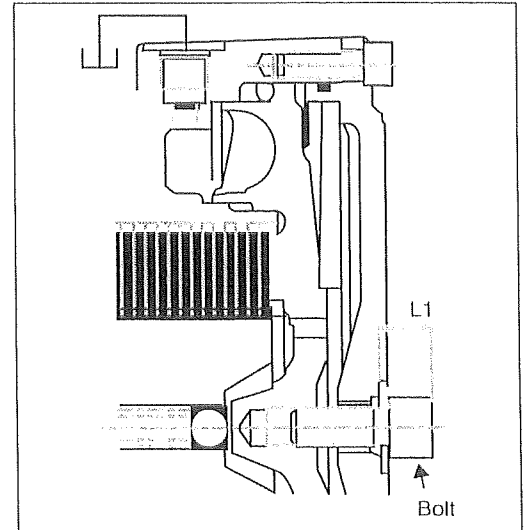

2) Checking the brake stroke

Measure the height of bolt head by means of depth slide calipers while complete releasing pressure being applied to the brake releasing pilot port (brake released). <L2>

$$\text{Brake stroke} = L2 - L1$$

★ Specified value

The brake stroke is proper if it remains within the range shown below.

If it exceeds, adjust it with shim(s) in use.

	DCM0280
Brake stroke length for new disk.	1.6 ~ 2.3

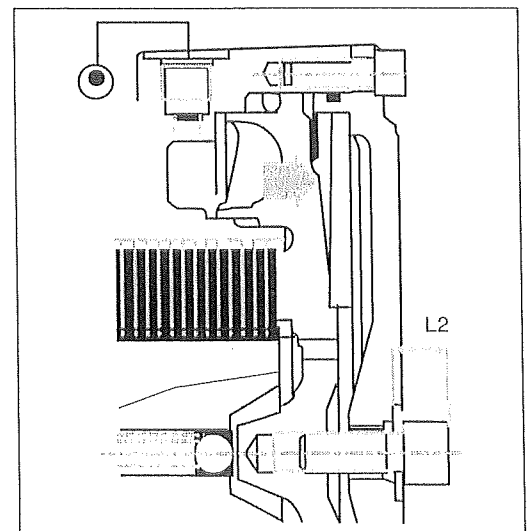

3. PERIODICAL MAINTENANCE

3) Plug installation

Install hex. socket plug (D63, D64) complete with O-ring to the forced brake releasing port.

【Forced brake releasing port plug tightening torque】

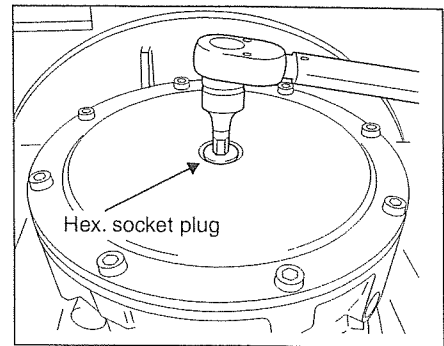

	DCM0280
Size of plug	G1 / 4
Distance across socket	6mm
Tightening torque	27 ~ 31N-m

On the cam motor brake disk, slight shrinkage will take place, after initial commissioning, due to running-in effect. It has been set on the higher side for new disk by taking it into account.

Replacement standard

In any of the following cases, replace friction plate and separate plate totally.

- (1) When braking force drops below hydraulic motor drive force.
(Despite that brake is actuated, hydraulic motor rotates when HST drive is actuated).
- (2) When friction plate and separate plate are seized.
- (3) When brake piston stroke exceeds 3.5mm (See following details).

Measuring the brake piston stroke (Replacement standard)

1) Removing the plug.

Remove hex. socket plugs (D63) and (D64) complete with O-rings from the forced brake releasing port.

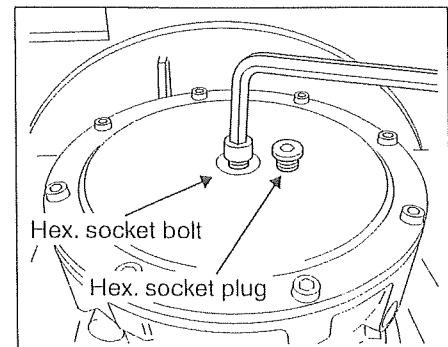

2) Forced releasing bolt

Install hex. socket bolt for forced brake releasing. Do not tighten the bolt all the way but leave it floating off the seat thereof.

	DCM0280
Bolt (Pitch)	M10×25L (1.5)

Leaving the brake releasing pilot port open to the atmosphere (with the brake locked), measure the distance from brake cover to bolt head by means of depth slide calipers. <L1>

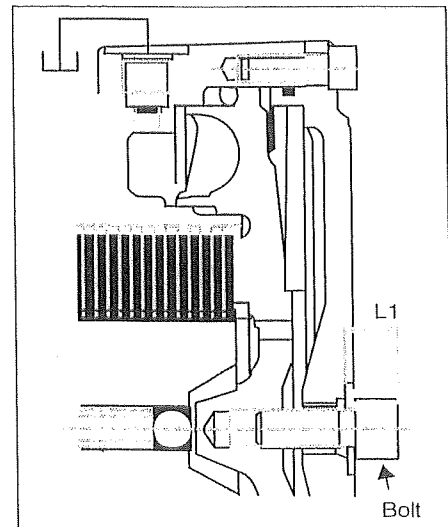

3) Checking the brake stroke

Measure the height of bolt head with the complete releasing pressure applied to the brake releasing pilot port (With the brake released). <L2>

Length of brake stroke = L2 - L1

★ In case the brake stroke exceeds replacement standard value shown below, replace friction plate and separate plate totally.

	DCM0280
Replacement standard brake stroke length	3.5mm

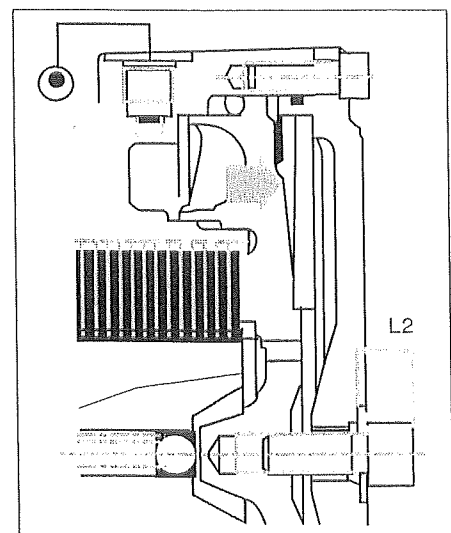

3. PERIODICAL MAINTENANCE

Exchange parts list

In addition to friction plate and separate plate, it is recommendable to replace relevant O-rings with new ones.

No	Item	Q'ty	Dwg. No. (Daikin Dwg. Nos./ Standard nominal)
			DCM0280
D12	Friction plate	14	SP1988
D13	Separate plate	15	1733585
D14	Brake shim package	1	1745162-S
D51	O-ring	1	KG1A105 / 1A G105
D52	O-ring	1	KG1A155 / 1A G155
D53	O-ring	1	KA1B164 / AS568-164
For reference only			
D02	(Brake cover)	(1)	(1723016-01)
D03	(Brake piston)	(1)	(1723017-01)
D04	(Brake shaft)	(1)	(1733583)
D11	(Brake spring)	(1)	(1733584)
D21	(Brake shaft spring)	(1)	(1745653)
D22	(Steel ball $\phi 12.7$)	(1)	(HKW04)
D42	(Hex. socket bolt)	(8)	(AAM0602001 / M6×20, 12.9T)
D63	(Hex. socket plug)	(1)	(HP11020-2)
D64	(O-ring)	(1)	(KP1B011 / 1B-P11)

NOTE: Items in parentheses are shown here for reference only and do not need to be replaced.

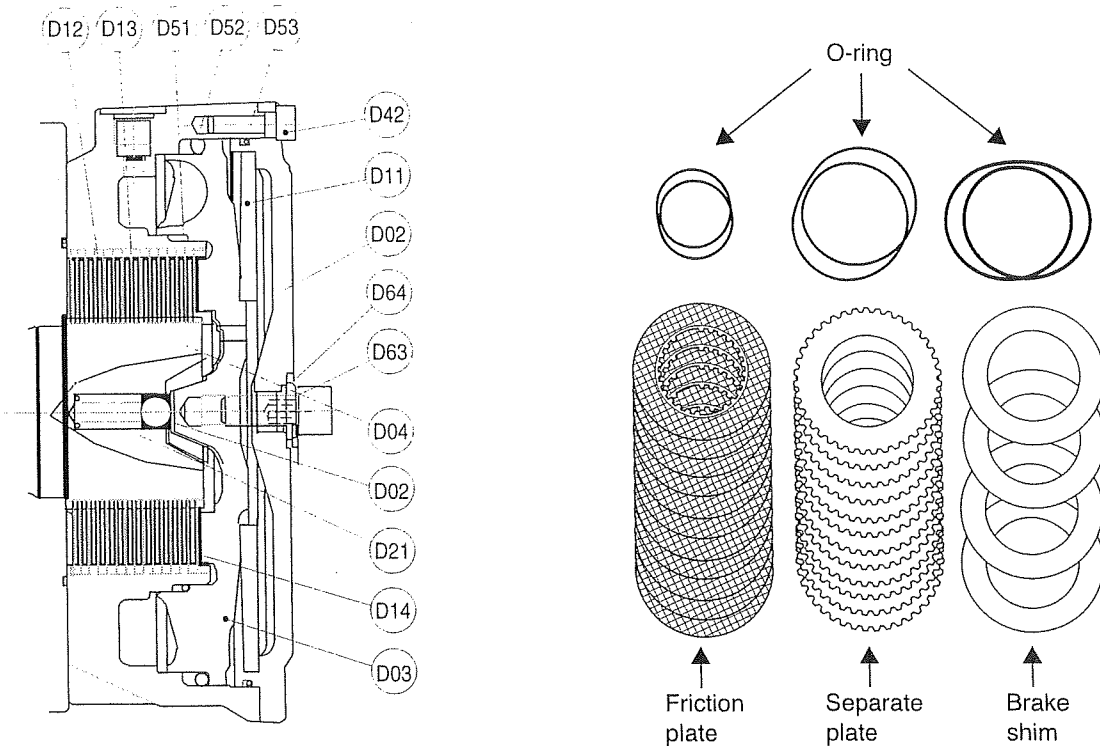

3. PERIODICAL MAINTENANCE

⑳ Vibrator

- 1) Rotate the drum till the drain plug comes to bottom.
- 2) Remove drain plug, level gauge plug and filler plug.
- 3) Drain oil from vibrator.
- 4) Clean the vibrator before reinstalling it.
- 5) Feed oil at filler port until oil flows out of level gauge hole.
- 6) Reinstall the level gauge plug as well as filler plug after cleaning them.

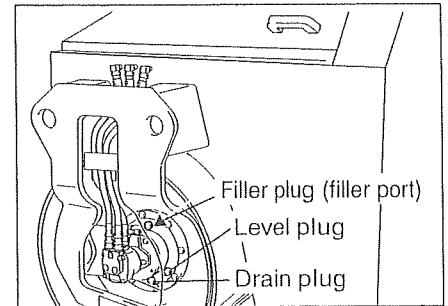

⚠ WARNING
When draining a hot oil, use care not to get burned.

㉑ Shockmounts:Engine mount

Check the rubber blocks for cracks, and their mounting bolts for looseness.

(8) As required

㉒ Fuel tank

- 1) With the drain plug removed, remove the water and sediment from the bottom of the tank.
- 2) If sedimentation is substantial, clean the interior of the tank.
- 3) When the necessary work and refueling are complete, tighten the filler cap positively.

NOTE: When removing the water and sediment from the tank filled with the fuel, the fuel will gush out if the drain plug is screwed out completely.

⚠ WARNING

- The fuel will catch fire if open flames or ignition sources are used close to it.
- Do not smoke or use a match or cigarette lighter close to it.

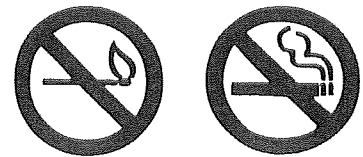

㉓ Shockmounts:Roll mount

Check the rubber blocks for cracks, and their mounting bolts for looseness.

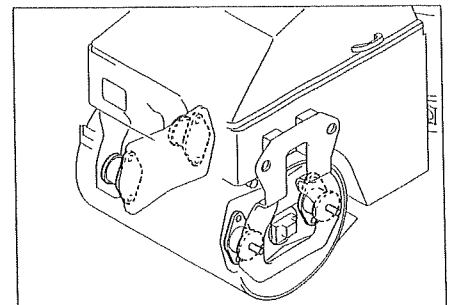

3. PERIODICAL MAINTENANCE

⑪ Sprinkler filter

Take off the filter case by turning counter-clockwise as viewed from the bottom. Clean the element. Change the element if necessary

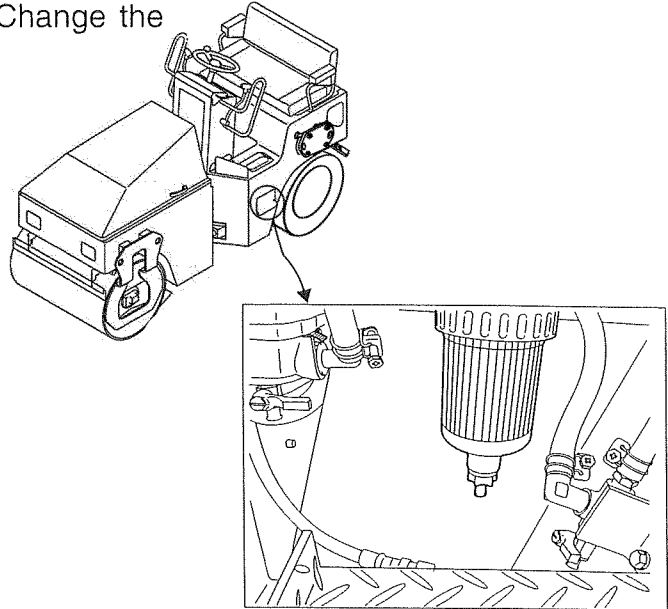

⑫ Sprinkler tank

Close the selector valve located under the driver's seat by turning 90 degrees counter-clockwise.

Open the drain cap on the lower right of the driver's station. Drain the sediment from the tank with water fed from the fill hole.

When draining is complete, close the drain cap. Open the switchover valve by turning 90 degrees clockwise.

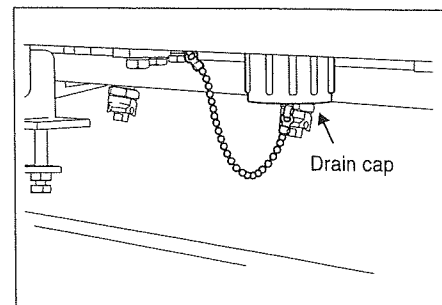
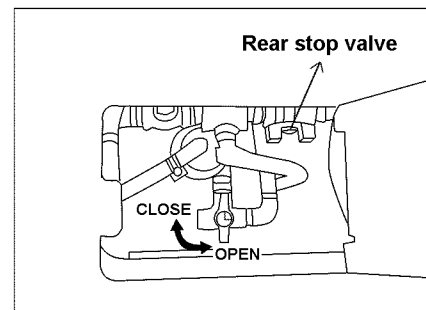

NOTE: Close the selector valve when splinking operation is complete, water is drained and the machine is stored for long.

3. PERIODICAL MAINTENANCE

⑬ Sprinkler pipe, nozzle

- 1) Clean inside of the sprinkler pipe with the pipe cocks open and the water sprinkler operated.
- 2) Take off the one-touch removal nozzles from the sprinkler pipe or remove the caps from the nozzles. Take out nozzle filters.
- 3) Clean the filters. Use a needle or the like to clean nozzle hole. Refit the filters to the nozzles.

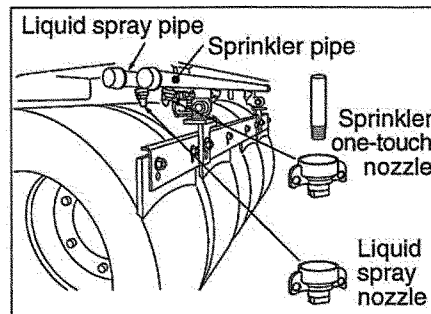
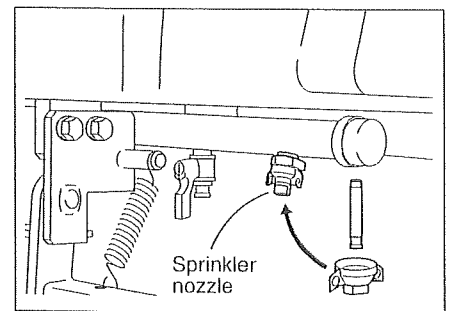
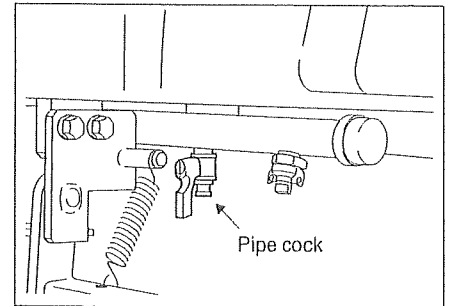

⑮ Scraper

- When the gap between the drum and blade has grown large, adjust the scraper properly. See page 26 for adjustment.
- To clear muds accumulated between the drum and scraper blade, raise the blade.

⚠ WARNING

Be careful not to pinch your fingers between the drum and blade.

⑭ Air cleaner

- 1) Unclip and remove the cover. Withdraw the element.
- 2) Blow compressed air from inside of the element to clean.

⚠ WARNING

Exercise caution not to get a speck of dust in your eye.

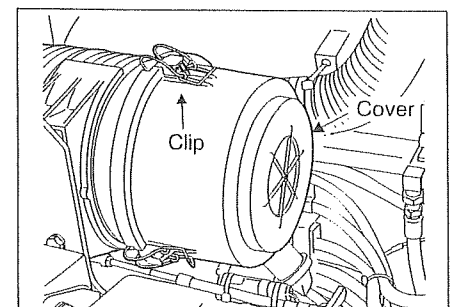

- 3) After washing, refit the element and cover. Fix the cover with the clip.

NOTE: Change the element once in every six cleanings.

3. PERIODICAL MAINTENANCE

③⑩ Liquid spray filter

Remove the filter case located on the lower right of the driver's station. Clean or change the element.

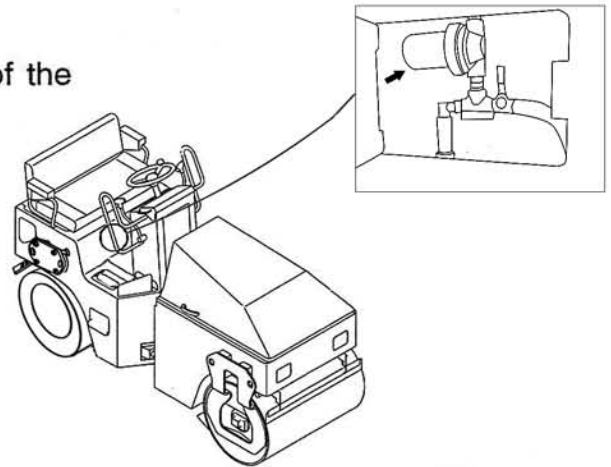

②⑨ Electric bulbs

Make sure that all the electric bulbs (indicator and warning lamps inside the monitor display, turn signal indicator lamps, headlamps, Flood lamps and rear combination lamps) light up or blink by operating switches on the operation panel. If they do not light up, replace them with new ones.

②⑧ Hood shocks

Lift the hood up and check that the hood is retained up by gas dampers of the hood shocks. If the hood does not stay up, replace the hood shocks with new ones.

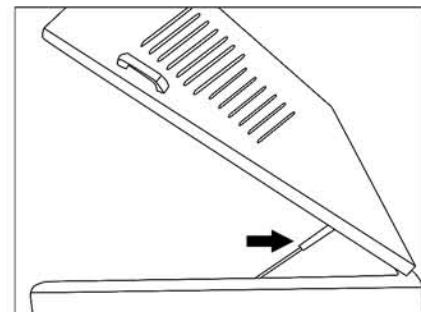

3. PERIODICAL MAINTENANCE

3.5 Consumable Parts

Replace consumable parts such as filter elements and air cleaner elements during periodical maintenance or before reaching the wear limit. Proper replacement of consumable parts will improve the overall life of the machine, resulting in cost-effective operations.

Use genuine SAKAI parts as replacement parts.

The part numbers are subject to change due to the improvements to the parts. When ordering parts, make sure to obtain the latest part numbers by checking with our distributorship or one of our certified service shops of the version, model name and model

TW320-1, TW330-1

Consumable Part	Part No.	Interval		Remark
		Annual replacement (year)	Replacement per operation (hours)	
Engine oil filter cartridge	4031-33006-0		200	
Fuel filter cartridge	4031-33002-0		450	
Air cleaner element assembly	4418-00000-0			As required
Outer element	4417-96000-0			As required
Suction filter element (hydraulic oil)	4210-68000-0 4205-50000-0		500	
Line filter cartridge (hydraulic oil)	4213-46000-0		500	
Sprinkler filter element	4703-68000-0			As required
Liquid spray filter element	4710-38000-0			As required
Sprinkler nozzle assembly	4710-41000-0			As required
Nozzle	4710-41004-0			As required
O-ring	4710-41003-0			As required
Strainer	4710-41005-0			As required
Liquid spray nozzle assembly	4715-94000-0			As required
Nozzle	4708-30000-0			As required
O-ring	4715-86002-0			As required
Scraper blade (front wheel)	1445-71310-0(TW320-1) 1445-71507-0(TW330-1)			As required
Scraper blade (rear wheel)	1447-71006-0			As required
Hood shock (gas damper)	4418-04000-0	2		

3. PERIODICAL MAINTENANCE

3.6 Feeding Water and Lubricants

1. General rules

- 1) Never feed water or lubricant with the strainer removed.
- 2) Use recommended lubricant and hydraulic fluid.
- 3) Do not use lubricants and hydraulic fluid of different brands.
- 4) When replacing oil, drain it completely and clean the container with flushing oil before filling new oil.

2. Capacity

Compartment	Type of fluid	Capacity in liters (gal.)	
		TW320-1	TW330-1
Fuel tank	Diesel oil	43 (11.3)	←
Engine oil pan	Engine oil	7 (1.8)	←
Hydraulic tank	Hydraulic oil	42 (11.1)	←
Vibrator	Gear oil	4.0 (1.1)	4.8 (1.3)
Radiator	Coolant	7.0 (1.8)	←
Sprinkler tank	Water	180 (47.6)	←
Liquid tank	Liquid	10 (2.6)	←

3. PERIODICAL MAINTENANCE

3. Rating

Lubricant	Service classification	Ambient temp. and applicable viscosity rating			Applicable standards
		-15 ~ 30°C (5 ~ 86°F) Cold	0 ~ 40°C (32 ~ 104°F) Moderate	15 ~ 55°C (59 ~ 131°F) Tropical	
Engine oil	API grade CD	SAE 10W-30	SAE 30	SAE 40	MIL-L-2104D
Gear oil	API grade GL4	SAE 80W-90	SAE 90	SAE 140	MIL-L-2105
Hydraulic oil	Wear resistant	ISO-VG32 over VI 140	ISO-VG46 over VI 140	ISO-VG68 over VI 110	ISO-3448
Grease	Lithium type extreme pressure				NLGI-2
Fuel	Diesel oil				ASTM D975-2D

4. Recommended lubricants

Lubricant Oil company	Engine oil API – CC	Gear oil API GL 4	Hydraulic oil VG 46	Grease (NLGI – II)
CALTEX	RPM DELO 300 oil	Universal Thuban 90	Rando Oil HD 46	Martifack EP 2
BP	BP Vanellus C3-30	BP Gear Oil EP 90	BP Energol HLP 46	BP Energrease LS – EP 2
ESSO	Esso Lube D3-30	Esso Gear Oil GP 90	Nuto H 46	Beacon EP 2
MOBIL	Mobil Delvac 1330	Mobil Pegasus Gear Oil 90	Nuto Oil 25	Beacon EP 25
SHELL	Shell Rotella CT Oil 30	Shell Spirax 90 EP	Shell Tellus Oil 46	Shell Alvania EP Grease 2
CASTROL	Castrol CRD 30	Castrol Hypoy 90	Hyspin AWS 46	Spherrol ELP 2

- CAUTION:** (1) Fill the fluid reservoirs with the filters installed.
 (2) Use recommended fuels and lubricants only.

3. PERIODICAL MAINTENANCE

3.7 Electric Wiring Diagram

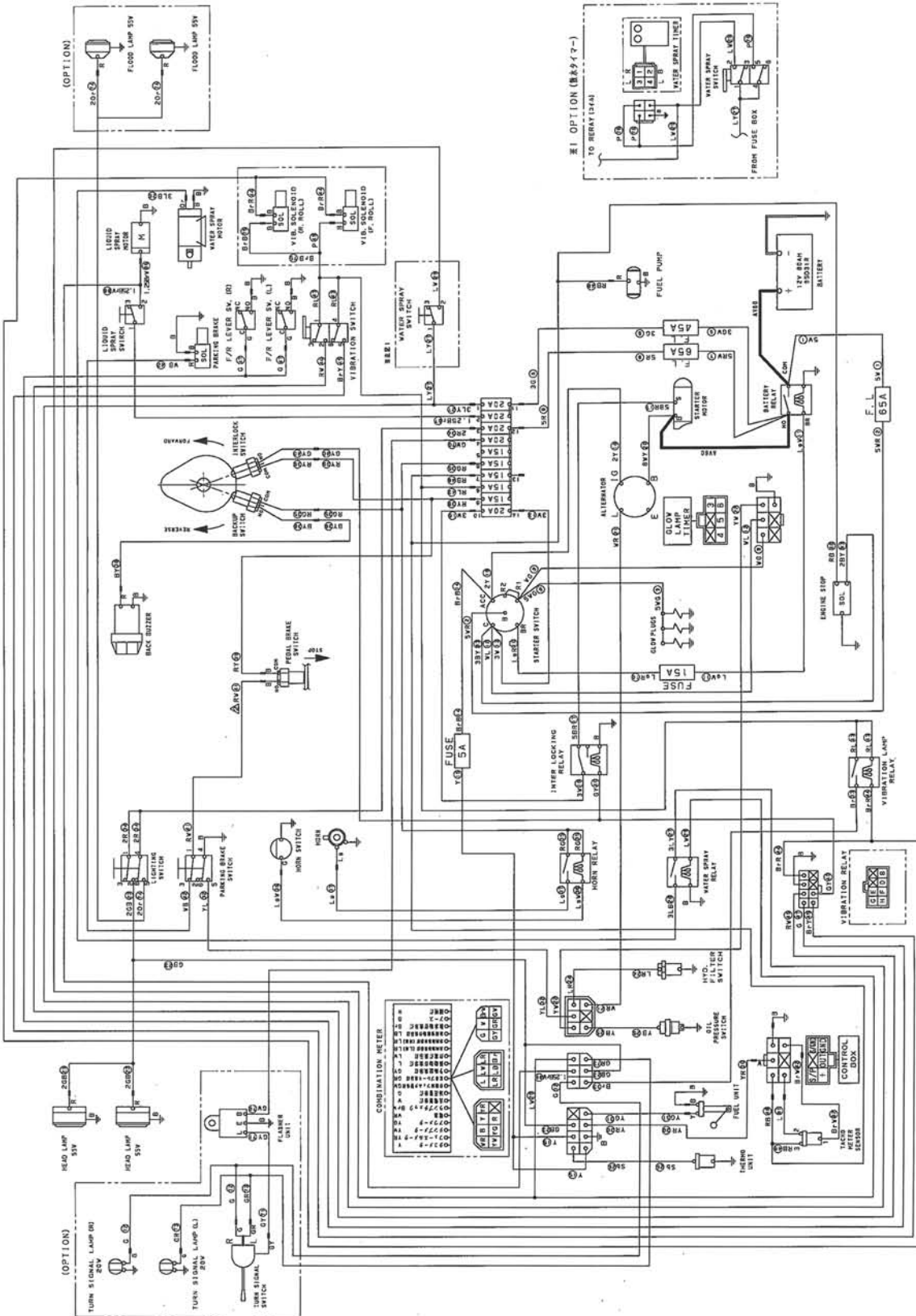

CAUTION: Size of wires not indicated by letters are AV 0.85.

Color of wire

B	Black	Black	P	Pink	RW	Red/White stripe	WR	White/Red stripe	YR	Yellow/Red stripe	LB	Blue/Black stripe
BR	Black/Red stripe	GR	R	Red	RY	Red/Yellow stripe	Y	Yellow	YW	Yellow/White stripe	WG	White/Green stripe
BW	Black/White stripe	GW	RB	Red/Black stripe	W	White	YB	Yellow/Black stripe	BY	Brown/Yellow stripe		
BY	Black/Yellow stripe	GY	RG	Red/Green stripe	WB	White/Black stripe	YG	Yellow/Green stripe	Sb	Blue stripe		
Br	Brown	L	RL	Red/Blue stripe	WL	White/Blue stripe	YL	Yellow/Blue stripe	BG	Black/Green stripe		
		O	O	Orange								
		LR	LR	Blue/Red stripe								
		LW	LW	Blue/White stripe								
		LY	LY	Blue/Yellow stripe								
		Lg	Lg	Light green								
		GR	GR	Green/Red stripe								
		GW	GW	Green/White stripe								
		GY	GY	Green/Yellow stripe								
		Gr	Gr	Gray								
		GL	GL	Green/Blue stripe								

Fuse box

The fuse box houses five 15A- and five 20A- fuses lined up with spares fitted for 15A- and 20A- fuses.

Use fuses of correct capacity. See page 25.

NOTE: When a fuse is burned, determine the cause before replacing.

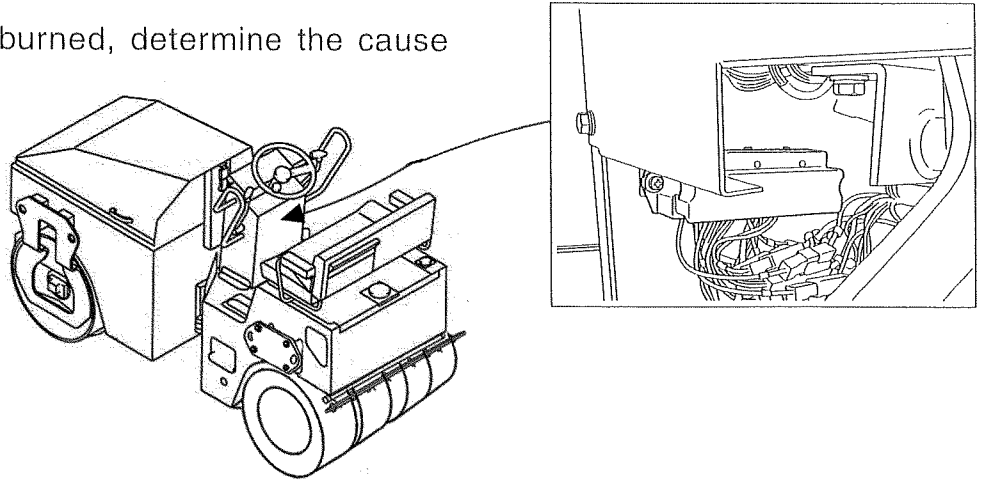

Battery

- ★ Leaving the battery unused for long without attention or its power excessively at a time can cause damage to the plates, leading to a shortened life.
- ★ For long-term storage, charge it fully, tighten the caps securely, store in a cool and dry place, and check the level of charge at least once a month.
- ★ Maintain the level of charge above 75%.
- ★ In cold weather, it is desirable to start the engine with the battery charged 100% Do not try to start the engine with less than 75%.

4. SPECIFICATIONS

4. SPECIFICATIONS

(1) TW320-1

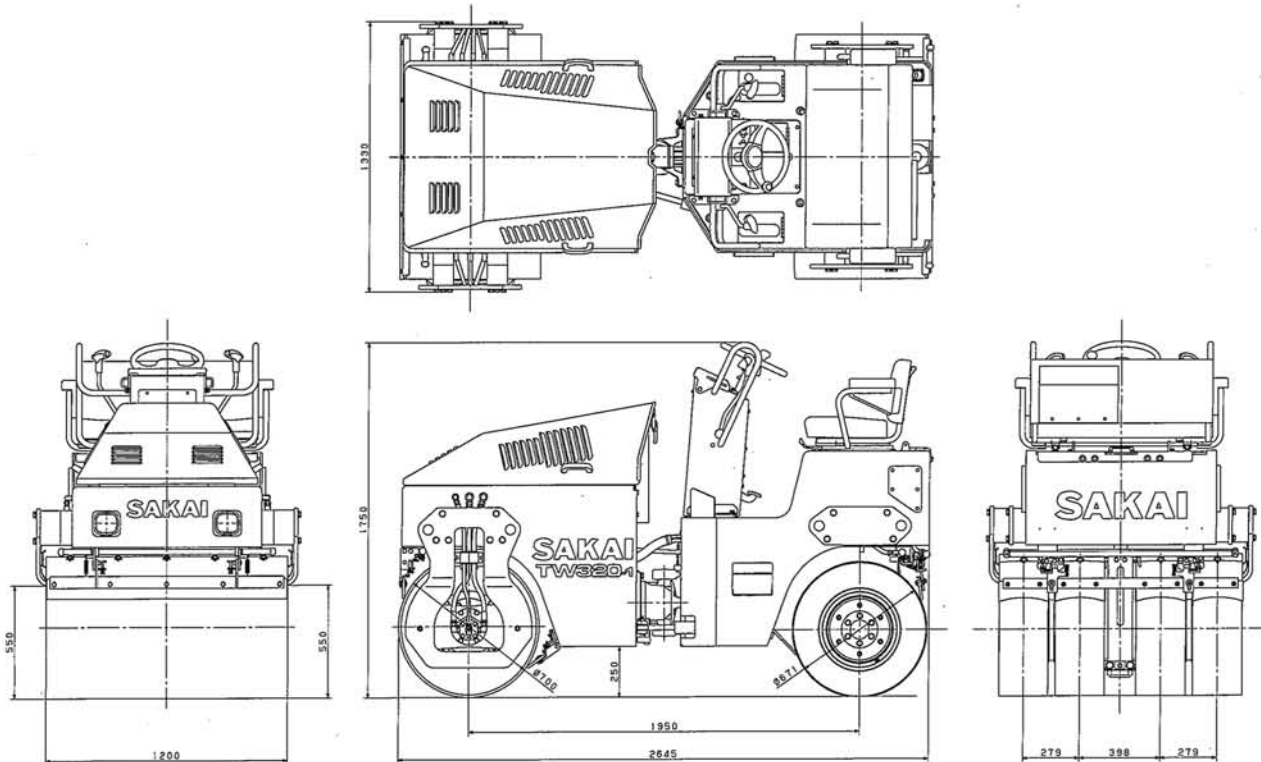

Model	TW320-1		Vibrating power:	
Weight:			Frequency	66.7Hz {4,000 vpm}
Gross weight	2,710 kg (5,975 lbs)		Centrifugal force	31.4 kN {2,800 kgf} (7,055 lbs)
Empty weight	2,520 kg (5,555 lbs)		Gradability	21 degrees
Dimension:			Rolling width	1,200 mm (47")
Overall length	2,645 mm (104")		Minimum turning radius	3.8 m (150")
Overall width	1,330 mm (52 ")		Engine:	
Overall height	1,750 mm (69")		Model	KUBOTA "D1703-M-ET01" Diesel Engine
Wheelbase	1,950 mm (77")		Total displacement	1.647 liters {1,647 cc} (100.5 cu.in)
Wheel			Rated output	26.1 kW {35.5 PS} / 2,800 min ⁻¹ (35.0 HP/2,800 rpm)
Front	Roll (dia. x width)		Max. torque	104N · m {10.6 kg-f · m} / 1,600 min ⁻¹ (76.7 ft-lb/1,600 rpm)
	700 x 1,200 mm (28" x 47")		Tank capacity:	
Rear	Tires		Fuel tank	43 liters (11.4 gal)
	9.5/65-15-6PR(OR)		Hydraulic tank	42 liters (11.1 gal)
Performance:			Sprinkler tank	180 liters (48 gal)
(forward / reverse)	0 ~11.7km/h (0 ~ 7.3 mile/h)			

NOTE: Gradability is the calculated value. It may vary with ground surface conditions.

(2) TW330-1

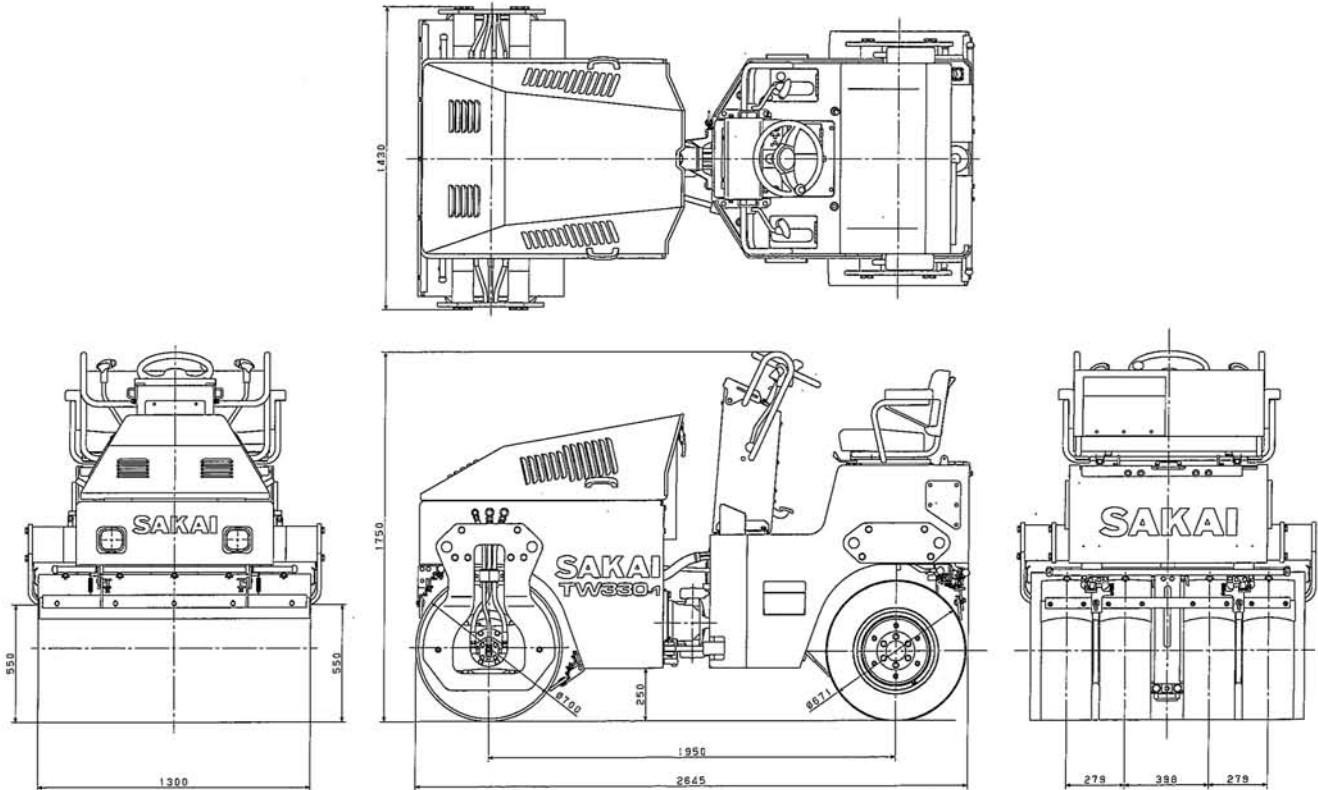

Model		TW330-1		Vibrating power:	
Weight:				Frequency	66.7Hz {4,000 vpm}
Gross weight	2,750 kg (6,060 lbs)	Centrifugal force	31.4kN {3,200 kgf} (7,055 lbs)	Gradability	20 degrees
Empty weight	2,560 kg (5,645 lbs)	Rolling width	1,300 mm (51")	Minimum turning radius	3.8 m (150")
Dimension:				Engine:	
Overall length	2,645 mm (104")	Model	KUBOTA "D1703-M-ET01" Diesel Engine		
Overall width	1,430 mm (56")	Total displacement	1.647 liters {1,647 cc} (100.5 cu.in)		
Overall height	1,750 mm (69")	Rated output	26.1kW {35.5PS} / 2,800 min ⁻¹ (35.0HP/2,800 rpm)		
Wheelbase	1,950 mm (77")	Max. torque	104N·m {10.6 kg·f·m} / 1,600 min ⁻¹ (76.7 ft·lb/1,600 rpm)		
Wheel		Tank capacity:			
Front	Roll (dia. x width) 700 x 1,300 mm (28" x 51")	Fuel tank	43 liters (11.4 gal)		
Rear	Tires 9.5/65-15-6PR(OR)	Hydraulic tank	42 liters (11.1 gal)		
Performance: (forward / reverse)				Sprinkler tank	180 liters (48 gal)
0 ~11.7km/h (0 ~ 7.3 mile/h)					

NOTE: Gradability is the calculated value. It may vary with ground surface conditions.

SAKAI HEAVY INDUSTRIES , LTD.

Head Office: 1-4-8, Shiba Daimon, Minato-ku,
Tokyo, Japan

Telephone: Tokyo (03) 3431-9971

Facsimile: (03) 3436-6212

SAKAI HEAVY INDUSTRIES(SHANGHAI), LTD.

917# BAI YIN ROAD JIADING INDUSTRIAL PARKS SHANGHAI,CHINA

OFFICE TEL : (86)21-62196461 FAX : (86)21-62196417

SERVICE TEL : (86)21-62196463