

SW300-1
SW/TW320-1
TW/TW330-1
SHOP MANUAL

SAKAI®

3498-64454-0

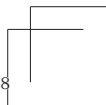
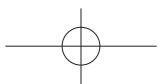
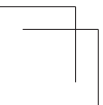
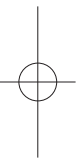
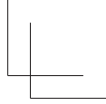
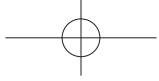
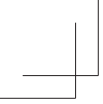

Introduction

This manual provides important information to familiarize you with safe operating and maintenance procedures for your SAKAI roller. Even though you may be familiar with similar equipment you must read and understand this manual before operating or servicing this unit.

Safety is everyone's business and it is one of your primary concerns. Knowing the guidelines presented in this manual will help provide for your safety, for the safety of those around you and for the proper operation and maintenance of the machine. Improper operation is dangerous and can result in injury or death.

Sakai Heavy Industries cannot foresee all possible circumstances or varying conditions to which the operator, serviceman or machine may be exposed to that might lead to a potential hazard. Therefore, the warnings and cautions listed in this manual and those placed on the machine are not intended to be all inclusive and liability for personal injury or damage to equipment or property cannot be assumed.

All information, specifications and illustrations in this publication are based on the product information available at the time that the publication was written. The contents may change without prior notice due to modifications of the model.

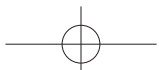
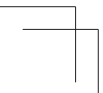
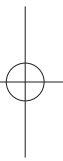
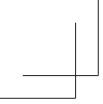

CONTENTS

1. SAFETY

1. GENERAL SAFETY

1-1. Understanding the Safety Symbols and Words	1-001
1-2. General	1-001
1-3. Qualifications of Operators and Maintenance Personnel	1-002
1-4. Safety Practices and Policies.....	1-002
1-5. Pre Start Inspection.....	1-003
1-6. Safety Instructions	1-003
1-7. Starting.....	1-004
1-8. Operating.....	1-004
1-9. Stopping	1-004
1-10. Maintenance.....	1-005
1-11. Transporting the Machine	1-007

2. SPECIFICATIONS

1. SPECIFICATION DATA

1-1. SW300-1	2-001
1-2. SW320-1	2-003
1-3. SW330-1	2-005
1-4. TW320-1	2-007
1-5. TW330-1	2-009

2. TABLE OF STANDARD VALUES

2-1. Engine.....	2-011
2-2. Propulsion.....	2-011
2-3. Hydraulic System.....	2-012
2-4. Steering.....	2-012
2-5. Brakes.....	2-013
2-6. Capacities.....	2-013

3. FUEL AND LUBRICANTS SPECIFICATION

3-1. Rating	2-014
3-2. Recommended Lubricants	2-014

4. TIGHTENING TORQUE CHART.....

2-015

3. ENGINE AND CONTROLS

1. ENGINE	
1-1. Engine Mount	3-001
1-2. Engine Exterior	3-002
2. CONTROL SYSTEM	
2-1. Throttle Control	3-003
2-2. Forward-reverse Control	3-004
3. PUMP MOUNT	
3-1. Pump Mount	3-005
3-1-1. Installation of pump	3-006

4. HYDRAULIC SYSTEMS

1. SYSTEM CIRCUIT DIAGRAM	
1-1. Graphic Symbols for Hydraulic Circuits	4-001
1-2. Hydraulic Circuit Diagram	4-003
1-2-1. Hydraulic circuit diagram (SW types)	4-003
1-2-2. Hydraulic circuit diagram (TW types)	4-004
2. PROPULSION HYDRAULIC SYSTEM	
2-1. Propulsion Hydraulic Piping	4-005
2-1-1. Propulsion hydraulic piping (1) (SW types: main)	4-005
2-1-2. Propulsion hydraulic piping (1) (TW types: main)	4-006
2-1-3. Propulsion hydraulic piping (2) (SW/TW types: front)	4-007
2-1-4. Propulsion hydraulic piping (3) (SW types: rear)	4-008
2-1-5. Propulsion hydraulic piping (3) (TW types: rear)	4-009
2-2. Hydraulic Component Specifications	4-010
2-2-1. Propulsion pump	4-010
2-2-2. Propulsion hydraulic motor (SW types: front and rear, TW types: front)	4-012
2-2-3. Propulsion hydraulic motor (TW types: rear)	4-013
2-2-4. Differential lock valve (TW types)	4-014
3. VIBRATOR HYDRAULIC SYSTEM	
3-1. Vibrator Hydraulic Piping	4-015
3-1-1. Vibrator hydraulic piping (1) (SW types: main)	4-015
3-1-2. Vibrator hydraulic piping (1) (TW types: main)	4-016
3-1-3. Vibrator hydraulic piping (2) (SW/TW types: front)	4-017
3-1-4. Vibrator hydraulic piping (3) (SW types: rear)	4-018
3-2. Hydraulic Component Specifications	4-019
3-2-1. Vibrator pump	4-019
3-2-2. Vibrator hydraulic motor	4-020
3-2-3. Vibrator solenoid valve	4-021

4. STEERING SYSTEM	
4-1. Steering Hydraulic Piping	4-022
4-2. Steering Wheel	4-023
4-3. Hydraulic Component Specifications	4-024
4-3-1. Steering charge pump	4-024
4-3-2. Orbitrol	4-025
4-4. Frame (Center Pin)	4-026
5. ELECTRICAL SYSTEM	
1. SYSTEM CIRCUIT DIAGRAM	
1-1. Electrical Circuit Diagram (SW types)	5-001
1-2. Electrical Circuit Diagram (TW types)	5-002
2. ELECTRICAL COMPONENTS	
2-1. Electrical Component Layout	5-003
3. ELECTRICAL COMPONENT SPECIFICATIONS	
3-1. Fuse Box	5-004
3-2. Combination Meter	5-005
6. VIBRATORY DRUM • REAR WHEEL	
1. PRECAUTIONS FOR DISASSEMBLY AND REASSEMBLY	6-001
2. VIBRATORY DRUM	
2-1. Removal and Installation of Vibratory Drum	6-003
2-1-1. Removal of front vibratory drum	6-004
2-1-2. Removal of rear vibratory drum	6-006
2-1-3. Removal of plate	6-008
2-1-4. Installation of vibratory drum	6-009
3. VIBRATORY DRUM ASSY	
3-1. Vibratory Drum ASSY	6-010
3-2. Disassembly and Reassembly of Vibratory Drum	6-011
3-2-1. Disassembly of vibratory drum	6-011
3-2-2. Reassembly of vibratory drum	6-021
4. REAR AXLE	
4-1. Rear Axle ASSY (TW Types)	6-039
4-2. Removal and Installation of Rear Axle (TW Types)	6-040
4-2-1. Removal of rear axle	6-041
4-2-2. Installation of rear axle	6-044

7. BRAKE

- 1. BRAKE PEDAL7-001
- 2. BRAKE SYSTEM.....7-002
 - 2-1. SW types7-002
 - 2-2. TW types7-003

8. SPRAY SYSTEMS

- 1. WATER SPRAY SYSTEM.....8-001
 - 1-1. Water Spray Piping (SW types).....8-001
 - 1-2. Water Spray Piping (TW types).....8-002
- 2. LIQUID SPRAY SYSTEM (TW TYPES)8-003

9. INSPECTION AND ADJUSTMENT

- 1. INSPECTION AND ADJUSTMENT
 - 1-1. Safety Precautions for Inspection and Adjustment9-001
 - 1-2. Preparation for Inspection and Adjustment9-001
 - 1-3. Precautions for Inspection and Adjustment9-001
 - 1-4. Warm-up.....9-001
 - 1-5. Inspection and Adjustment of Engine Related Items9-001
- 2. MEASUREMENT AND INSPECTION OF PROPULSION CIRCUIT PRESSURE
 - 2-1. Measurement9-002
 - 2-2. Inspection9-003
- 3. MEASUREMENT AND ADJUSTMENT OF PROPULSION CHARGE CIRCUIT PRESSURE
 - 3-1. Measurement9-004
 - 3-2. Adjustment9-005
- 4. MEASUREMENT OF PARKING BRAKE RELEASE PRESSURE
 - 4-1. Measurement9-006
 - 4-1-1. SW types: front and rear, TW types: front9-006
 - 4-1-2. TW types: rear9-007
- 5. MEASUREMENT OF VIBRATOR CIRCUIT PRESSURE
 - 5-1. Measurement (SW types: front and rear, TW types: front)9-008
- 6. MEASUREMENT AND INSPECTION OF STEERING CIRCUIT PRESSURE
 - 6-1. Measurement9-009
 - 6-2. Inspection9-010
- 7. MEASUREMENT OF HYDRAULIC PUMP CASE PRESSURE
 - 7-1. Measurement of Propulsion Pump Case Pressure9-011

8. MEASUREMENT OF PROPULSION MOTOR CASE PRESSURE	
8-1. Measurement	9-012
8-1-1. SW types: front and rear, TW types: front	9-012
8-1-2. TW types: rear	9-013
9. ADJUSTMENT OF THROTTLE LEVER LINKAGE	
9-1. Adjustment	9-014
10. ADJUSTMENT OF F-R LEVER LINKAGE	
10-1. Adjustment	9-015

10. TROUBLESHOOTING

1. TROUBLESHOOTING	
1-1. Safety Precautions for Troubleshooting	10-001
1-2. Important Information for Troubleshooting	10-001
1-3. Before Starting	10-002
1-4. Wire Color Code and Number	10-002
2. ELECTRICAL SYSTEM TROUBLESHOOTING	
2-1. When Performing Electrical System Fault Diagnosis	10-003
2-1-1. Precautions to take during electrical circuit fault diagnosis	10-003
2-1-2. Inspection procedures using a tester	10-004
2-1-3. Inspection of electrical system	10-009
2-2. Engine	10-012
2-2-1. Engine will not start (Starter motor does not run) 1/2	10-012
2-2-1. Engine will not start (Starter motor does not run) 2/2	10-014
2-2-2. Engine will not start (But starter motor runs)	10-016
2-2-3. Engine does not stop running	10-016
2-2-4. No charging	10-018
2-2-5. Glow plug is not heated (Engine starting performance is bad in cold weather)	10-018
2-2-6. Starter motor runs even when F-R lever is not at "N"	10-018
2-3. Propulsion	10-020
2-3-1. Machine moves neither forward nor backward	10-020
2-3-2. Brake cannot be released	10-022
2-3-3. Brake does not work	10-024
2-4. Vibration	10-026
2-4-1. No vibration occurs	10-026
2-4-2. Vibration mode cannot be switched (F-R lever vibration switch does not work)	10-028

2-5. Spray System	10-030
2-5-1. Water spray does not operate	10-030
2-5-2. Liquid spray does not operate (TW types)	10-032
2-6. Lighting	10-034
2-6-1. Head lamp does not light	10-034
2-6-2. Illumination of combination meter does not turn on	10-036
2-6-3. Combination meter warning lamp or indicator lamp is abnormal	10-036
2-6-4. Tachometer reading is abnormal	10-038
2-6-5. Hour meter is abnormal	10-038
2-6-6. Temperature meter is abnormal	10-040
2-6-7. Fuel meter is abnormal	10-040
2-6-8. Hydraulic oil filter warning lamp remains ON	10-042
2-6-9. Engine oil pressure warning lamp remains ON	10-042
2-6-10. Vibration indicator lamp does not light	10-044
2-6-11. Parking brake indicator lamp does not light	10-046
2-6-12. Water spray indicator lamp does not light	10-048
2-6-13. Liquid spray indicator lamp does not light (TW types)	10-048
2-6-14. Preheating indicator lamp does not light	10-050
2-6-15. Horn does not sound	10-052
2-6-16. Backup buzzer does not sound	10-052
3. HYDRAULIC SYSTEM TROUBLESHOOTING	
3-1. When Performing Hydraulic System Troubleshooting	10-053
3-2. Propulsion System	10-054
3-2-1. Machine moves neither forward nor backward 1/2	10-054
3-2-1. Machine moves neither forward nor backward 2/2	10-055
3-2-2. Machine moves in one direction only (forward or backward)	10-055
3-2-3. Slow machine speed or small drive force 1/2	10-055
3-2-3. Slow machine speed or small drive force 2/2	10-056
3-2-4. Machine does not stop completely with F-R lever in "N"	10-056
3-2-5. Driving not possible with differential locked (TW types)	10-056
3-2-6. Propulsion system is overheating	10-057
3-2-7. Abnormal noise from propulsion system	10-057
3-3. Vibrator System	10-058
3-3-1. No vibration	10-058
3-3-2. Vibrator frequency is too low	10-059
3-3-3. Vibrator does not stop	10-059
3-3-4. Vibrator system is overheating	10-059
3-3-5. Abnormal noise from vibrator system	10-060

3-4. Steering System	10-061
3-4-1. Steering wheel is hard to turn	10-061
3-4-2. Steering response is slow	10-061
3-4-3. Steering wheel backlash or play is large	10-062
3-4-4. Steering system is overheating	10-062
3-4-5. Abnormal noise from steering system	10-062

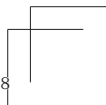
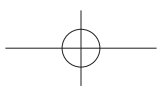
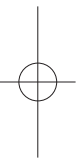
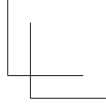
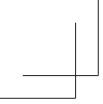

SAFETY

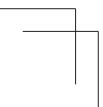
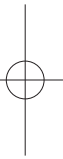
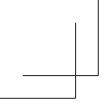



1. GENERAL SAFETY

1-1. Understanding the Safety Symbols and Words

The words DANGER, WARNING, and CAUTION are used with the safety-alert symbol. DANGER identifies the most serious hazard. When the symbols DANGER, WARNING and CAUTION are displayed, become alert. Your safety or those around you may be involved. NOTICE is used to provide important information that is not hazard related.

 **DANGER:** Indicates an imminently hazardous situation or condition which if not avoided can result in serious personal injury or death.

 **WARNING:** Indicates a potentially hazardous situation or condition which if not avoided can result in serious personal injury or death.

 **CAUTION:** Indicates a potentially hazardous situation or condition which if not avoided may result in moderate personal injury or damage to the machine or personal property.

(NOTICE): Indicates important information about operation or maintenance of the machine that may cause damage, breakdown, or shortened service life of the machine if you fail to observe or important point to maintain of quality in maintenance works.

★ : Indicates standard value to judge whether measured value is good or not.



Items that indicate the weight of a part or equipment and require attention in wire selection and operating posture for slinging operation.



In the assembly operation, tightening torque in locations that require particular attention.

1-2. General

- Operators and maintenance personnel must be alert to recognize and avoid potential hazards. They should also have comprehensive training, the required skills and necessary tools to perform the job safely.
- The machine was built in accordance to the latest safety standards and recognized safety rules. Nevertheless, misuse of the machine may result in risk to life and limb of the user or nearby personnel and may cause damage to the machine or other property.
- The machine must only be used for its intended purpose as described in the Operator's Manual. It must be operated by safety-conscious persons who are fully aware of the risks involved when operating the machine. Any malfunctions especially those affecting the safety of the machine must be corrected immediately.

SAFETY

- The machine is designed specifically for the compaction of asphalt or soil road construction materials. Use of the machine for other purposes such as towing other equipment is considered contrary to the designated use. The manufacturer cannot be responsible or held liable for any damage resulting from such use. The risk for such use lies entirely with the user.
- Operating the machine within the limits of its designated use also involves compliance with the inspection and maintenance requirements contained in the Operation and Maintenance Manual.

1-3. Qualifications of Operators and Maintenance Personnel

- Work on the machine must be performed by qualified personnel only. Individual responsibilities of personnel regarding operation, maintenance, repair of the machine must be clearly stated.
- Define the operator's responsibilities; the operator should have authority to refuse instructions that are contrary to safety.
- Do not allow persons being trained to operate or perform maintenance on the machine without constant supervision by an experienced person.
- Work on the electrical system of the machine must be done only by an experienced person or under the guidance of a skilled electrician and according to electrical engineering rules and regulations.
- Work on the frame, brakes, hydraulic and steering systems must be performed by skilled personnel with special knowledge and training for such work.

1-4. Safety Practices and Policies

- Keep the manuals in the container provided on the machine. Manuals must always be available at the site where the machine is being used.
- The operator or user of the machine must be aware of all applicable or legal and mandatory regulations relevant to accident prevention and environmental protection. These regulations may also deal with handling of hazardous substances, the required proper personal safety and protective equipment and traffic or jobsite regulations.
- Machine operating instructions should also be supplemented with detailed instructions pertaining to the specific jobsite or work location.
- Always be sure the persons working on the machine have read the operating instructions and all safety precautions before beginning work. Reading safety instructions after work has already begun is too late.
- Wear close fitting garments and always tie back and secure long hair, also avoid wearing jewelry such as rings. Injury can result from loose clothing, hair or jewelry being caught up in the machinery or rotating parts.
- Use protective equipment as required by the circumstances or by law.

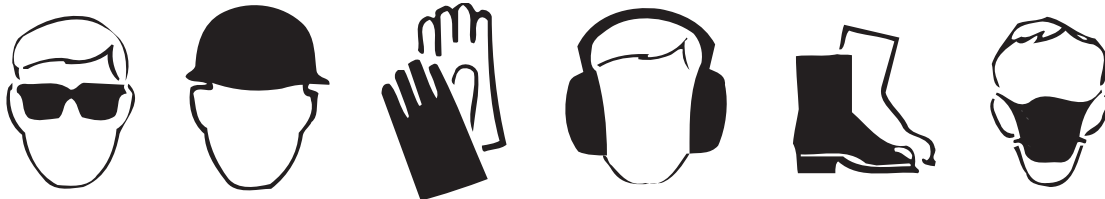

- Observe all safety instructions and warnings attached to the machine.
- Make sure all safety instructions and warnings on the machine are complete and perfectly legible.
- Stop the machine immediately in the event of any malfunction. Report any malfunction immediately to the supervisor or other person of authority.
- Never perform service or maintenance on the machine unless the drums or tires are adequately blocked, articulation lock bar and pin is in the locked position and the parking brake is applied.
- Never make any modifications to the machine which might affect safety without the manufacturer's approval.
- Always perform the recommended routine inspections and adjustments according to the prescribed intervals.

1-5. Pre Start Inspection

- Inspect your machine daily. Ensure that the routine maintenance and lubrication are properly performed. Repair or replace any malfunctioning, broken or missing parts before using the machine. Refer to the maintenance schedule in the Operator's Manual.
- Check that all instructions and safety stickers are in place and readable.
- Never fill the fuel tank with the engine running or while near an open flame or while smoking.
- Always clean up any spilled fuel.
- Check for any warning tags placed on the machine, do not operate the machine until all repairs have been made and warning tags have been removed by authorized personnel.
- Check the seat belt for wear or damage; inspect the belt hardware and fabric. Replace if hardware is damaged or the belt is frayed or nicked or stitching is loose. Check that mounting hardware is tight.
- Clean the steps and operating platform of dirt and foreign matter to reduce danger of slipping.
- Know how to shut-down or stop the machine immediately in case of emergency.
- Know the capabilities and limitations of the machine such as speed, gradeability, steering and braking.
- Be aware of the dimensions of the machine such as height, weight especially for transporting.

1-6. Safety Instructions

- Take all necessary precautions to ensure that the machine is used only when in a safe and reliable condition.
- Avoid any operational mode that might compromise safety.
- Operate the machine only if all protective and safety devices are in place and fully functional.
- Always use the hand rails and steps to get on and off your machine maintaining 3-point contact (using both hands).

1-7. Starting

- Start the machine only from the driver's seat and always wear the seat belt.
- Watch that the warning lights and indicators during start-up and shutdown are working in accordance with operating instructions.
- Watch that no one is in danger before starting and when moving the machine.
- Check that braking, steering, signals and lights are fully functional before starting work or traveling with the machine.

1-8. Operating

- Always make sure that there are no obstructions or persons in your line of travel before starting the compactor in motion.
- Never climb on and off the machine while it is in motion.
- Always remain seated with the seat belt fastened when traveling, compacting or loading or unloading the machine.
- Use caution and be very observant when operating in close quarters and congested areas.
- Obey all traffic regulations when working on public roads and make sure machine is compatible with these regulations.
- Never carry passengers.
- Know and use the hand signals for particular jobs and who has the responsibility for signaling.
- Do not work close to edges or in the vicinity of overhanging banks or on grades that could cause the compactor to slide or roll over. Avoid any areas that may be a risk to machine stability.
- Avoid side hill travel. Always operate up and down the slope. Always keep the propulsion (travel control) lever in low speed range when climbing or descending hills or steep grades.
- Make sure there is sufficient clearance when crossing underpasses, bridges and tunnels or when passing under overhead power lines.
- Never allow anyone to stand in the articulation area of the machine when the engine is running.
- Always look in all directions before reversing the direction of travel.
- Always switch on the lighting system (if equipped) during poor visibility conditions and after dark.
- Do not attempt to control the compactor travel speed with the throttle control. Maintain engine speed at the full operating RPM.
- Do not run the engine in a closed building for an extended period of time. Exhaust fumes can kill.

1-9. Stopping

- Always park the machine in a safe area on solid and level ground. If this is not possible, always park at a right angle to the slope and block the drums or tires.
- Do not leave the operator's platform with the engine running. Always move the travel lever to neutral position and apply the parking brake then turn the starter switch to OFF.
- Lock all lockable compartments.

- Park behind a safe barrier, use proper flags, and warning devices, especially when parking in areas of heavy traffic.

1-10. Maintenance

- In any performing any work concerning the operation, adjustment or modification of the machine or it's safety devices or any work related to maintenance, inspection or repair, always follow the start-up and shut-down procedures in the Operator's Manual and the Maintenance Manual.
- Ensure that the maintenance area is safe and secure.
- If the machine is shut down for maintenance or repair work it must be secured against inadvertent starting by removing the starter key and attaching a warning sign to the starter switch.
- The machine must be parked on stable and level ground with the drums or tires blocked to prevent inadvertent movement.
- Immediately after the engine has stopped, the exhaust system, engine, radiator coolant, engine oil, hydraulic fluid and other lubricants and components will be very hot. Fluids can be under pressure, removing the radiator cap or draining oil or changing filters can cause serious burns. Wait until the machine has cooled down.
- Use care when attaching and securing lifting tackle to individual parts and large assemblies being removed or repositioned for repair purposes to avoid the risk of accident. Use lifting devices that are in perfect condition and of sufficient lifting capacity. Never stand under suspended loads.
- Always use the proper tools and workshop equipment in good condition when performing maintenance or repairs on the machine.
- Always use specially designed safety ladders and working platforms when working above floor level. Never use machine parts as a climbing aid.
- Keep all steps, handles, handrails, platforms and ladders free from mud, dirt, grease, ice or snow.
- Clean the machine, especially threaded connections of any traces of oil or fuel before carrying out any maintenance or repairs. Never use aggressive detergents. Use lint free cleaning rags.
- Examine all fuel, lubricant and hydraulic fluid lines and connectors for leaks, loose connections chafe marks or damage after cleaning.
- Repair or replace defective parts immediately.
- Whenever possible, avoid servicing or maintenance when the engine is running unless the drums or tires are adequately blocked, the articulation lock bar is in the locked position and the parking brake is applied.



SAFETY

- Never fill the fuel tank with the engine running, while near an open flame or while smoking. Always clean up any spilled fuel.
- Ensure safe operation, optimum performance of the machine and its warranty by using only genuine SAKAI replacement parts.
- Use only the specified fluids and lubricants. Substitute only products known to be equivalent from reputable manufacturers.
- Disconnect the battery cables when working on the electrical system or when welding on the compactor.
- Be sure the battery area is well ventilated (clear of fumes) should it be necessary to connect a jumper cable or battery charger. Fumes can ignite from a spark and may explode.
- Be sure battery charger is OFF when making connections if charging is required.
- Use only original fuses with the specified rating. Switch off the machine immediately if trouble occurs in the electrical system.
- Work on the electrical system may only be carried out by a qualified electrician or by a specially trained person according to electrical engineering principles.
- Inspect the electrical equipment of the machine at regular intervals. Defects such as loose connections or burnt or scorched wires must be repaired or replaced immediately.
- Do not weld, flame cut or perform grinding on the machine unless expressly authorized, as there may be a risk of fire or explosion. Disconnect the battery when welding on the machine.
- Clean the machine and its surrounding from dust or other flammable substances and make sure the area is adequately ventilated before beginning welding, flame cutting or grinding operations.
- Inspect hydraulic hoses at regular intervals and immediately replace if they show signs of chafing, cracking, brittleness, deformation, blistering, fitting separation, leakage, corrosion or other damage which may affect their function or strength.
- Do not work on hydraulic system while the engine is running and the system is under pressure. The hydraulic system remains pressurized even after the engine has stopped.
- Do not disconnect hydraulic hoses or fittings until the pressure has been properly relieved.
- Wait until the systems and fluid have cooled down before disconnecting.
- Never use your hands to check for leaks when inspecting a hydraulic system. Use a piece of cardboard and always wear gloves and safety glasses.



- Get immediate medical attention if fluid has been injected under your skin. Fluid penetration from a pin hole leak can cause severe injury or death.
- Ensure that hydraulic lines and hoses are routed and fitted properly. Ensure that no connections are interchanged. All fittings, lengths and specifications of hoses must comply with the technical requirements.

- Observe all product safety regulations when handling fuel, oils, grease, engine coolant and other chemical substances. Be careful especially when these items are hot as there is a risk of burning or scalding.
- Operate internal combustion engines and fuel operated heating systems only in adequately ventilated premises. Before starting the engine in an enclosed area, make sure there is sufficient ventilation.



1-11. Transporting the Machine

- Use only suitable and approved trailers and haul vehicles and lifting equipment of sufficient capacity.
- Entrust to experienced personnel the fastening and lifting of loads and instructing of crane operators.
- Only experienced persons familiar with the operation of the machine may load and unload the machine.
- Use ramps or a loading dock when loading or unloading the machine. Ramps must be the proper strength, low angle and the proper height and width.
- Block the drums or tires (front and rear) of the hauling vehicle when loading and unloading the compactor. Ensure that the haul vehicle is on level ground and approach the loading ramps squarely to make sure that the compactor does not slide off the edge of the ramp.
- Keep the deck clear of mud, oil, ice or snow or other materials that can make the deck slippery.
- Position the compactor on the trailer or transport vehicle centered from side to side, and apply the brake. Shut off the engine and lock all lockable compartments.
- Block the drums or tires and lock the articulation lock bar. Chain the machine down properly using the appropriate tackle.
- Know the overall height of the compactor and hauling vehicle. Observe height and weight regulations and be sure you can pass safely at overhead obstructions.
- Obey all traffic regulations and be sure that the proper clearance flags, lights and warning signs including "Slow Moving Vehicle" emblem are displayed when traveling on public roads.
- Know the approximate stopping distance at any given speed.
- Drive Safely. Never turn corners at excessive speeds.

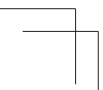
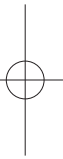
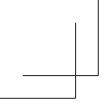

SPECIFICATIONS

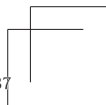
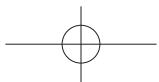
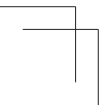
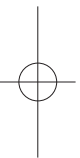
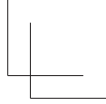
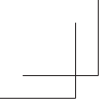

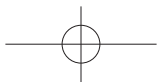
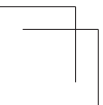
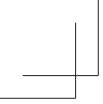

SPECIFICATIONS

1. SPECIFICATION DATA

1-1. SW300-1

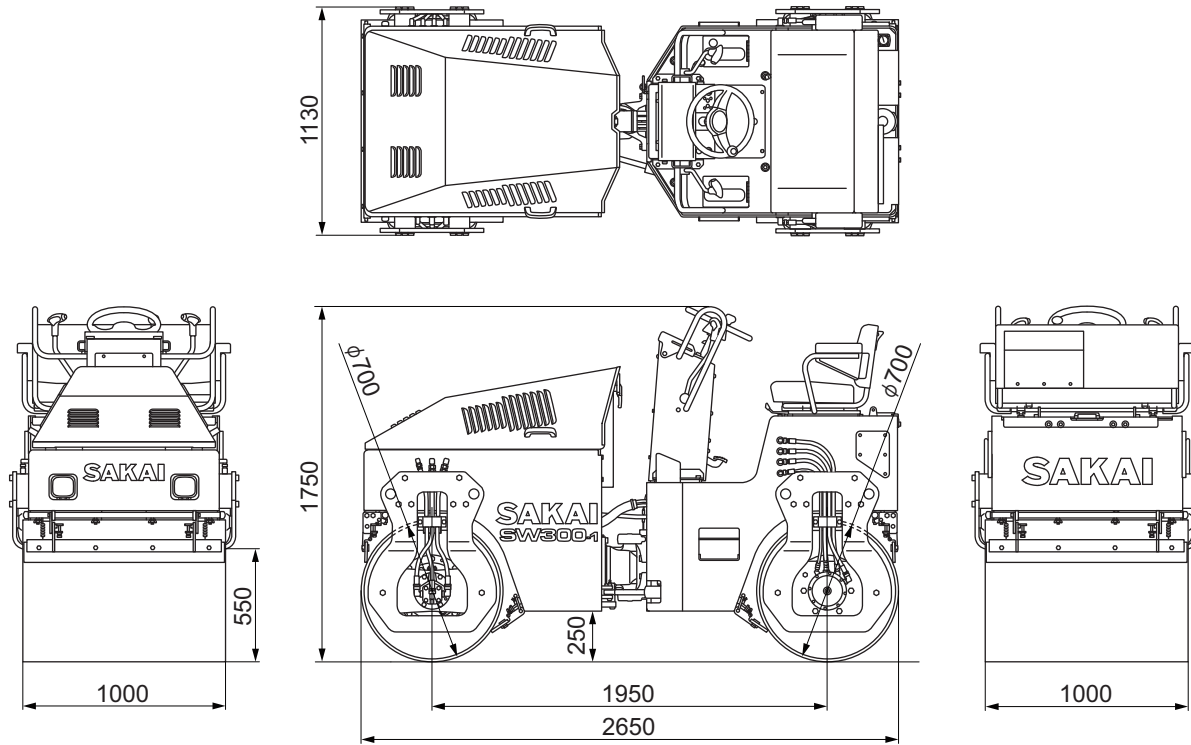

0445-99012-0-10689-0

Model		SW300-1	
Weight	Operating weight	2,725 kg	(6,010 lbs.)
	Front axle	1,315 kg	(2,900 lbs.)
	Rear axle	1,410 kg	(3,110 lbs.)
Dimensions	Overall length	2,650 mm	(104 in.)
	Overall width	1,130 mm	(44 in.)
	Overall height	1,750 mm	(69 in.)
	Wheelbase	1,950 mm	(77 in.)
	Compaction width	1,000 mm	(39 in.)
	Minimum height above ground	250 mm	(10 in.)
	Curb clearance	550 mm	(21.5 in.)
Speed (Forward & Reverse)		0 to 12 km/h	(0 to 7.5 mile/h)
Vibration performance	Frequency	66.7 Hz	
	Centrifugal force	27.5 kN	(6,175 lbs.)
Minimum turning radius		3.7 m	(146 in.)
Gradability *1		43 %	(23 °)

*1: The gradability is the calculated value. It may vary based on the ground surface conditions.

SPECIFICATIONS

Engine	Name		KUBOTA D1703-M-ET01 Diesel Engine		
	Model		Water-cooled, 4-cycle, 3-cylinder, in-line, vertical mounted, overhead valve, swirl combustion chamber type		
	Bore × Stroke		87.0 mm x 92.4 mm (3.425 in. x 3.638 in.)		
	Displacement		1.647 L (100.5 cu.in.)		
	Performance	Rated speed		2,800 min ⁻¹ (2,800 rpm)	
		Rated output (SAE J1995 JUN95)		26.1 kW (35.0 HP)	
		Max. torque (SAE J1995 JUN95)		104 N·m (76.7 lbf·ft) at 1,600 rpm ⁻¹	
		Fuel consumption (SAE J1349 JUN95)		272 g/kW·h (0.447 lb/HP·h) at rated speed	
	Governor		Mechanical all-speed type		
	Lubrication system		Pressure lubrication by gear pump		
	Oil filter		Full-flow: paper		
	Air cleaner		Dry type		
	Cooling system		Centrifugal pump forced feeding system (pressure type)		
	Cooling fan		Inhaling type		
	Electrical system	Alternator		12 V 60 A	
		Starter		12 V 2 kW	
Battery		12 V 80 Ah × 1 pcs. (12 V)			
Engine dry weight		159 kg (351 lbs.)			
Power line	Transmission	Type	Hydrostatic transmission		
		Speeds	Single speed shift		
	Reverser		Switching the direction of flow delivered from the variable pump		
Final drive		Direct drive			
Vibrating system	Transmission		Hydrostatic transmission		
	Vibrator		Eccentric shaft type		
Braking device	Service brake		Hydrostatic and mechanical, multi-wet disc type		
	Parking brake		Mechanical, multi-wet disc type		
Steering system	Steering control type		Hydraulic type (Articulated type)		
	Steering control angle		± 35 °		
	Oscillation angle		± 7.5 °		
Drums	Use	Front drum		Vibrate & Drive × 1	
		Rear drum		Vibrate & Drive × 1	
	Dimension	Front drum	width × diameter	1,000 mm × 700 mm (39 in. × 28 in.)	
		Rear drum	width × diameter	1,000 mm × 700 mm (39 in. × 28 in.)	
	Suspension system	Front		Rubber damper type	
Rear		Rubber damper type			
Water spray system		Pressurized type			
Others	Instruments & lights		1 set		

SPECIFICATIONS

1-2. SW320-1

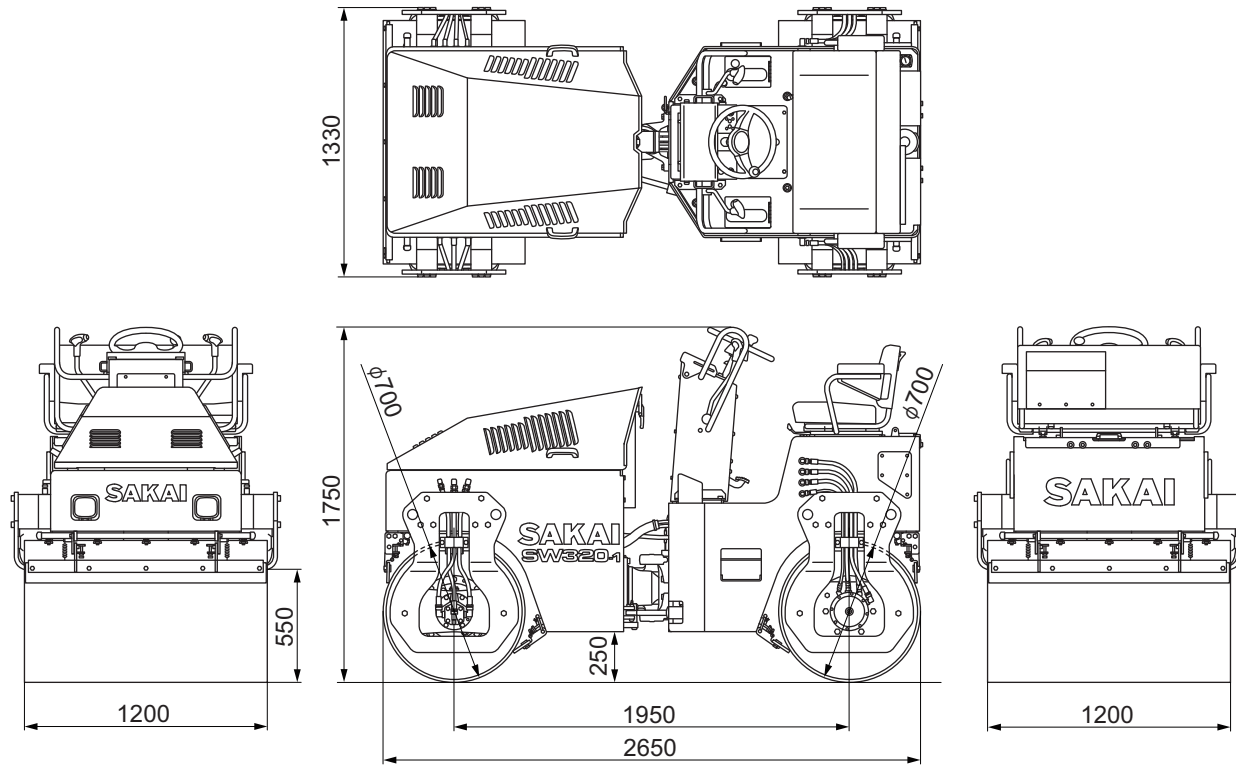

0445-99013-0-10690-0

Model		SW320-1	
Weight	Operating weight	2,890 kg	(6,370 lbs.)
	Front axle	1,400 kg	(3,085 lbs.)
	Rear axle	1,490 kg	(3,825 lbs.)
Dimensions	Overall length	2,650 mm	(104 in.)
	Overall width	1,330 mm	(52 in.)
	Overall height	1,750 mm	(69 in.)
	Wheelbase	1,950 mm	(77 in.)
	Compaction width	1,200 mm	(47 in.)
	Minimum height above ground	250 mm	(10 in.)
	Curb clearance	550 mm	(21.5 in.)
	Speed (Forward & Reverse)		0 to 12 km/h
Vibration performance	Frequency	66.7 Hz	
	Centrifugal force	31.4 kN	(7,055 lbs.)
Minimum turning radius		3.8 m	(150 in.)
Gradability *1		40 %	(21 °)

*1: The gradability is the calculated value. It may vary based on the ground surface conditions.

SPECIFICATIONS

Engine	Name		KUBOTA D1703-M-ET01 Diesel Engine		
	Model		Water-cooled, 4-cycle, 3-cylinder, in-line, vertical mounted, overhead valve, swirl combustion chamber type		
	Bore × Stroke		87.0 mm x 92.4 mm (3.425 in. x 3.638 in.)		
	Displacement		1.647 L (100.5 cu.in.)		
	Performance	Rated speed		2,800 min ⁻¹ (2,800 rpm)	
		Rated output (SAE J1995 JUN95)		26.1 kW (35.0 HP)	
		Max. torque (SAE J1995 JUN95)		104 N·m (76.7 lbf·ft) at 1,600 rpm ⁻¹	
		Fuel consumption (SAE J1349 JUN95)		272 g/kW·h (0.447 lb/HP·h) at rated speed	
	Governor		Mechanical all-speed type		
	Lubrication system		Pressure lubrication by gear pump		
	Oil filter		Full-flow: paper		
	Air cleaner		Dry type		
	Cooling system		Centrifugal pump forced feeding system (pressure type)		
	Cooling fan		Inhaling type		
	Electrical system	Alternator		12 V 60 A	
		Starter		12 V 2 kW	
Battery		12 V 80 Ah × 1 pcs. (12 V)			
Engine dry weight		159 kg (351 lbs.)			
Power line	Transmission	Type	Hydrostatic transmission		
		Speeds	Single speed shift		
	Reverser		Switching the direction of flow delivered from the variable pump		
Final drive		Direct drive			
Vibrating system	Transmission		Hydrostatic transmission		
	Vibrator		Eccentric shaft type		
Braking device	Service brake		Hydrostatic and mechanical, multi-wet disc type		
	Parking brake		Mechanical, multi-wet disc type		
Steering system	Steering control type		Hydraulic type (Articulated type)		
	Steering control angle		± 35 °		
	Oscillation angle		± 7.5 °		
Drums	Use	Front drum		Vibrate & Drive x 1	
		Rear drum		Vibrate & Drive x 1	
	Dimension	Front drum	width × diameter	1,200 mm x 700 mm (47 in. x 28 in.)	
		Rear drum	width × diameter	1,200 mm x 700 mm (47 in. x 28 in.)	
	Suspension system	Front		Rubber damper type	
Rear		Rubber damper type			
Water spray system		Pressurized type			
Others	Instruments & lights		1 set		

SPECIFICATIONS

1-3. SW330-1

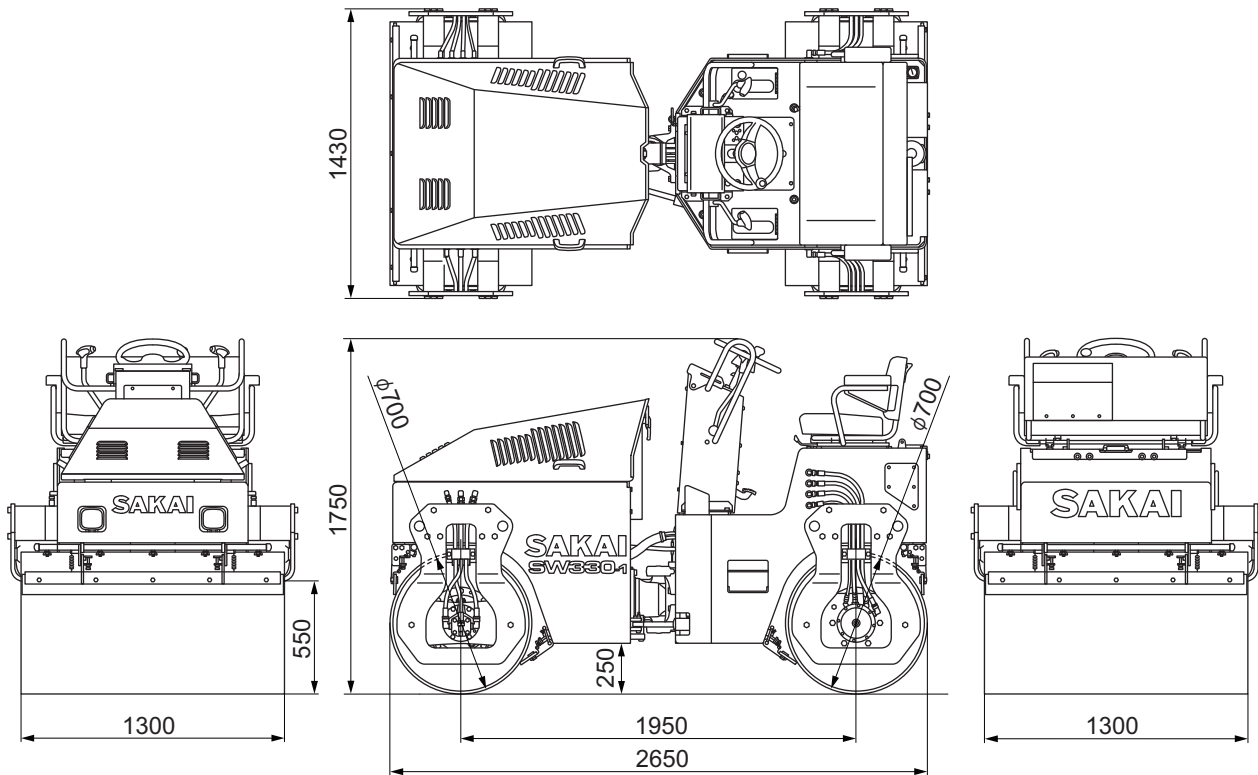

0445-99014-0-10691-0

Model		SW330-1	
Weight	Operating weight	2,970 kg	(6,550 lbs.)
	Front axle	1,440 kg	(3,175 lbs.)
	Rear axle	1,530 kg	(3,375 lbs.)
Dimensions	Overall length	2,650 mm	(104 in.)
	Overall width	1,430 mm	(56 in.)
	Overall height	1,750 mm	(69 in.)
	Wheelbase	1,950 mm	(77 in.)
	Compaction width	1,300 mm	(51 in.)
	Minimum height above ground	250 mm	(10 in.)
	Curb clearance	550 mm	(21.5 in.)
	Speed (Forward & Reverse)		0 to 12 km/h
Vibration performance	Frequency	66.7 Hz	
	Centrifugal force	31.4 kN	(7,055 lbs.)
Minimum turning radius		3.8 m	(150 in.)
Gradability *1		38 %	(20 °)

*1: The gradability is the calculated value. It may vary based on the ground surface conditions.

SPECIFICATIONS

Engine	Name		KUBOTA D1703-M-ET01 Diesel Engine		
	Model		Water-cooled, 4-cycle, 3-cylinder, in-line, vertical mounted, overhead valve, swirl combustion chamber type		
	Bore × Stroke		87.0 mm x 92.4 mm (3.425 in. x 3.638 in.)		
	Displacement		1.647 L (100.5 cu.in.)		
	Performance	Rated speed		2,800 min ⁻¹ (2,800 rpm)	
		Rated output (SAE J1995 JUN95)		26.1 kW (35.0 HP)	
		Max. torque (SAE J1995 JUN95)		104 N·m (76.7 lbf·ft) at 1,600 rpm ¹	
		Fuel consumption (SAE J1349 JUN95)		272 g/kW·h (0.447 lb/HP·h) at rated speed	
	Governor		Mechanical all-speed type		
	Lubrication system		Pressure lubrication by gear pump		
	Oil filter		Full-flow: paper		
	Air cleaner		Dry type		
	Cooling system		Centrifugal pump forced feeding system (pressure type)		
	Cooling fan		Inhaling type		
	Electrical system	Alternator		12 V 60 A	
		Starter		12 V 2 kW	
Battery		12 V 80Ah x 1 pcs. (12 V)			
Engine dry weight			159 kg (351 lbs.)		
Power line	Transmission	Type	Hydrostatic transmission		
		Speeds	Single speed shift		
	Reverser		Switching the direction of flow delivered from the variable pump		
	Final drive		Direct drive		
Vibrating system	Transmission		Hydrostatic transmission		
	Vibrator		Eccentric shaft type		
Braking device	Service brake		Hydrostatic and mechanical, multi-wet disc type		
	Parking brake		Mechanical, multi-wet disc type		
Steering system	Steering control type		Hydraulic type (Articulated type)		
	Steering control angle		± 35 °		
	Oscillation angle		± 7.5 °		
Drums	Use	Front drum		Vibrate & Drive × 1	
		Rear drum		Vibrate & Drive × 1	
	Dimension	Front drum	width × diameter	1,300 mm x 700 mm (51 in. x 28 in.)	
		Rear drum	width × diameter	1,300 mm x 700 mm (51 in. x 28 in.)	
	Suspension system	Front		Rubber damper type	
Rear		Rubber damper type			
Water spray system			Pressurized type		
Others	Instruments & lights		1 set		

SPECIFICATIONS

1-4. TW320-1

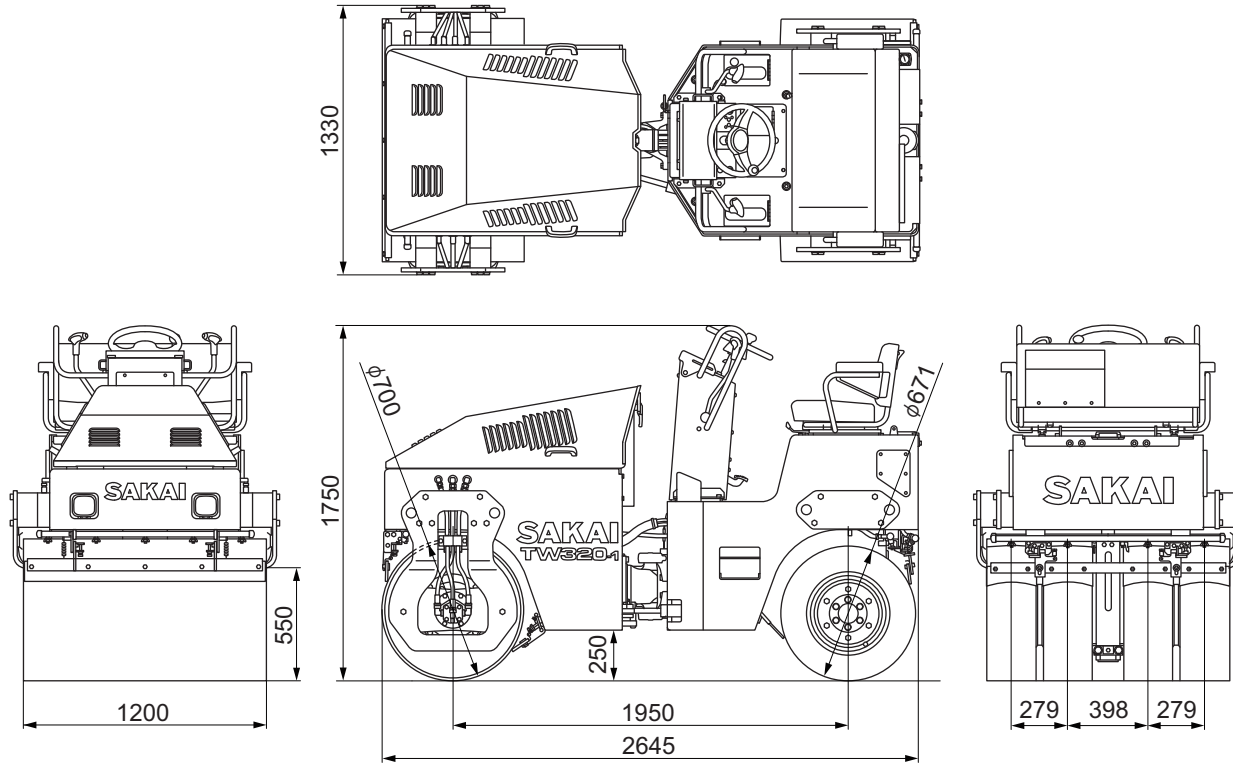

0425-99008-0-10079-0

Model		TW320-1	
Weight	Operating weight	2,710 kg	(5,975 lbs.)
	Front axle	1,410 kg	(3,110 lbs.)
	Rear axle	1,300 kg	(2,865 lbs.)
Dimensions	Overall length	2,645 mm	(104 in.)
	Overall width	1,330 mm	(52 in.)
	Overall height	1,750 mm	(69 in.)
	Wheelbase	1,950 mm	(77 in.)
	Compaction width	1,200 mm	(47 in.)
	Minimum height above ground	250 mm	(10 in.)
	Curb clearance	550 mm	(21.5 in.)
	Speed (Forward & Reverse)		0 to 11.7 km/h
Vibration performance (Front)	Frequency	66.7 Hz	
	Centrifugal force	31.4 kN	(7,055 lbs.)
Minimum turning radius		3.8 m	(150 in.)
Gradability *1		40 %	(21 °)

*1: The gradability is the calculated value. It may vary based on the ground surface conditions.

SPECIFICATIONS

Engine	Name		KUBOTA D1703-M-ET01 Diesel Engine		
	Model		Water-cooled, 4-cycle, 3-cylinder, in-line, vertical mounted, overhead valve, swirl combustion chamber type		
	Bore × Stroke		87.0 mm x 92.4 mm (3.425 in. x 3.638 in.)		
	Displacement		1.647 L (100.5 cu.in.)		
	Performance	Rated speed		2,800 min ⁻¹ (2,800 rpm)	
		Rated output (SAE J1995 JUN95)		26.1 kW (35.0 HP)	
		Max. torque (SAE J1995 JUN95)		104 N·m (76.7 lbf·ft) at 1,600 rpm ⁻¹	
		Fuel consumption (SAE J1349 JUN95)		272 g/kW·h (0.447 lb/HP·h) at rated speed	
	Governor		Mechanical all-speed type		
	Lubrication system		Pressure lubrication by gear pump		
	Oil filter		Full-flow: paper		
	Air cleaner		Dry type		
	Cooling system		Centrifugal pump forced feeding system (pressure type)		
	Cooling fan		Inhaling type		
	Electrical system	Alternator		12 V 60 A	
Starter		12 V 2 kW			
Battery		12 V 80 Ah x 1 pcs. (12 V)			
Engine dry weight		159 kg (351 lbs.)			
Power line	Transmission	Type	Hydrostatic transmission		
		Speeds	Single speed shift		
	Reverser		Switching the direction of flow delivered from the variable pump		
	Final drive	Front	Direct drive		
Rear		Direct drive			
Vibrating system	Transmission		Hydrostatic transmission		
	Vibrator		Eccentric shaft type		
Braking device	Service brake		Hydrostatic and mechanical, multi-wet disc type		
	Parking brake		Mechanical, multi-wet disc type		
Steering system	Steering control type		Hydraulic type (Articulated type)		
	Steering control angle		± 35 °		
	Oscillation angle		± 7.5 °		
Drum & tires	Use	Front drum		Vibrate & Drive × 1	
		Rear tires		Drive × 4	
	Dimension	Front drum	width × diameter	1,200 mm x 700 mm (47 in. x 28 in.)	
		Rear tire	size	9.5 / 65 - 15 - 6PR (OR), smooth tread	
	Suspension system	Front		Rubber damper type	
Rear		Rigid			
Water spray system		Pressurized type			
Liquid spray system		Pressurized type			
Others	Instruments & lights		1 set		

SPECIFICATIONS

1-5. TW330-1

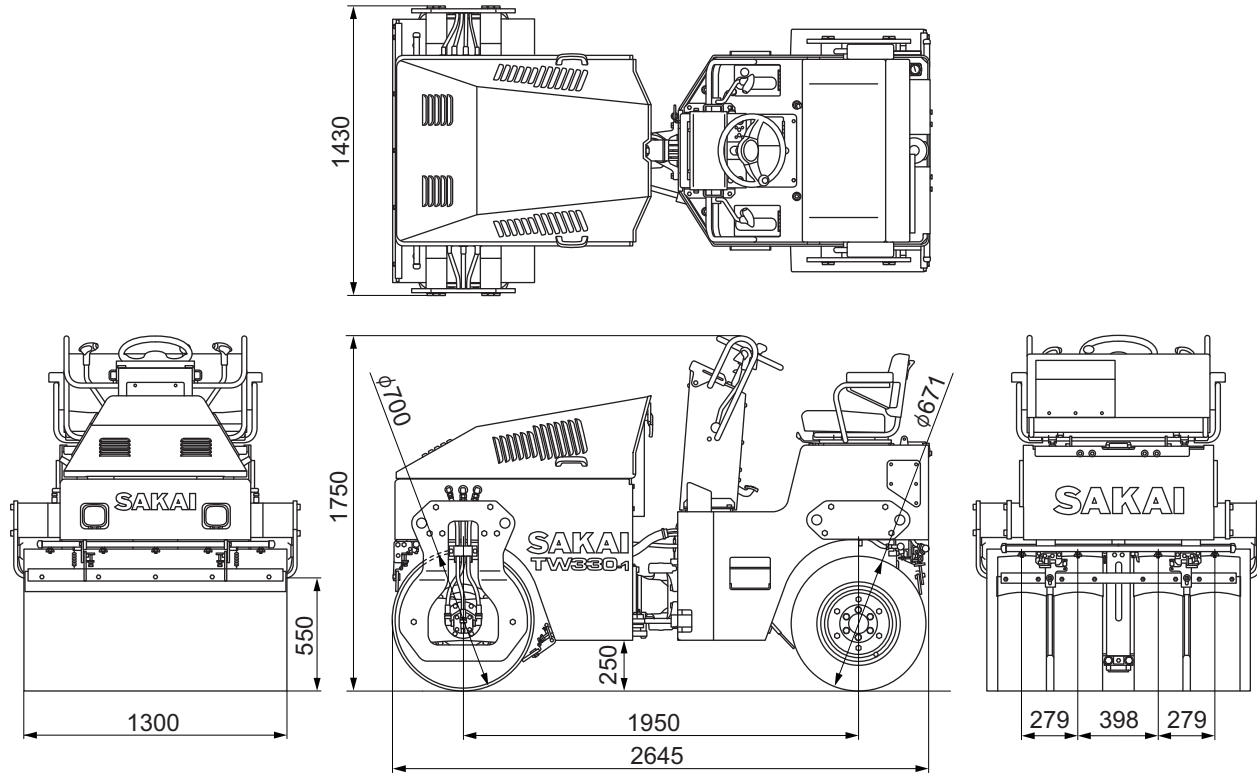

0425-99009-0-10080-0

Model		TW330-1	
Weight	Operating weight	2,750 kg	(6,060 lbs.)
	Front axle	1,450 kg	(3,195 lbs.)
	Rear axle	1,300 kg	(2,865 lbs.)
Dimensions	Overall length	2,645 mm	(104 in.)
	Overall width	1,430 mm	(56 in.)
	Overall height	1,750 mm	(69 in.)
	Wheelbase	1,950 mm	(77 in.)
	Compaction width	1,300 mm	(51 in.)
	Minimum height above ground	250 mm	(10 in.)
	Curb clearance	550 mm	(21.5 in.)
	Speed (Forward & Reverse)	0 to 11.7 km/h	(0 to 7.3 mile/h)
Vibration performance (Front)	Frequency	66.7 Hz	
	Centrifugal force	31.4 kN	(7,055 lbs.)
Minimum turning radius	3.8 m	(150 in.)	
Gradability *1	38 %	(20 °)	

*1: The gradability is the calculated value. It may vary based on the ground surface conditions.

SPECIFICATIONS

Engine	Name		KUBOTA D1703-M-ET01 Diesel Engine		
	Model		Water-cooled, 4-cycle, 3-cylinder, in-line, vertical mounted, overhead valve, swirl combustion chamber type		
	Bore × Stroke		87.0 mm x 92.4 mm (3.425 in. x 3.638 in.)		
	Displacement		1.647 L (100.5 cu.in.)		
	Performance	Rated speed		2,800 min ⁻¹ (2,800 rpm)	
		Rated output (SAE J1995 JUN95)		26.1 kW (35.0 HP)	
		Max. torque (SAE J1995 JUN95)		104 N·m (76.7 lbf·ft) at 1,600 rpm ⁻¹	
		Fuel consumption (SAE J1349 JUN95)		272 g/kW·h (0.447 lb/HP·h) at rated speed	
	Governor		Mechanical all-speed type		
	Lubrication system		Pressure lubrication by gear pump		
	Oil filter		Full-flow: paper		
	Air cleaner		Dry type		
	Cooling system		Centrifugal pump forced feeding system (pressure type)		
	Cooling fan		Inhaling type		
	Electrical system	Alternator		12 V 60 A	
Starter		12 V 2 kW			
Battery		12 V 80 Ah x 1 pcs. (12 V)			
Engine dry weight		159 kg (351 lbs.)			
Power line	Transmission	Type	Hydrostatic transmission		
		Speeds	Single speed shift		
	Reverser		Switching the direction of flow delivered from the variable pump		
	Final drive	Front	Direct drive		
Rear		Direct drive			
Vibrating system	Transmission		Hydrostatic transmission		
	Vibrator		Eccentric shaft type		
Braking device	Service brake		Hydrostatic and mechanical, multi-wet disc type		
	Parking brake		Mechanical, multi-wet disc type		
Steering system	Steering control type		Hydraulic type (Articulated type)		
	Steering control angle		± 35 °		
	Oscillation angle		± 7.5 °		
Drum & tires	Use	Front drum		Vibrate & Drive × 1	
		Rear tires		Drive × 4	
	Dimension	Front drum	width × diameter	1,300 mm x 700 mm (51 in. x 28 in.)	
		Rear tire	size	9.5 / 65 - 15 - 6PR (OR), smooth tread	
	Suspension system	Front		Rubber damper type	
Rear		Rigid			
Water spray system		Pressurized type			
Liquid spray system		Pressurized type			
Others	Instruments & lights		1 set		

SPECIFICATIONS

2. TABLE OF STANDARD VALUES

2-1. Engine

Item	Standard value		Remarks
Engine model	KUBOTA D1703-M-ET01 Diesel Engine		
Rated output	26.1/2,800 kW/min ⁻¹ (35/2,800 HP/rpm)		
Max. rpm under no load	3,000 rpm or less		With fan, when net
Min. rpm under no load	1,050 ±50 rpm		With fan, when net
Cylinder head tightening torque	93.2 to 98.0 N·m (68.8 to 72.3 lbf·ft)		
Intake manifold tightening torque	18 to 20 N·m (13 to 15 lbf·ft)		
Exhaust manifold tightening torque	18 to 20 N·m (13 to 15 lbf·ft)		
Fan belt tension	7.0 to 9.0 mm (0.28 to 0.35 in.)		When midpoint of belt pressed at 98 N (22 lbf)
Valve clearance (intake)	0.18 to 0.22 mm (0.0071 to 0.0086 in.)		
Valve clearance (exhaust)	0.18 to 0.22 mm (0.0071 to 0.0086 in.)		
Compression pressure	Standard value	3.24 to 3.72 MPa (470 to 540 psi)	290 min ⁻¹ (rpm)
	Allowable limit	2.55 MPa (370 psi)	290 min ⁻¹ (rpm)
Injection pressure	13.73 to 14.70 MPa (1,992 to 2,133 psi)		
Fuel consumption rate	272 g/kW·h (0.447 lb/HP·h)		
Intake air negative pressure	2.45 kPa (250 mmAq) or less		
Exhaust gas back pressure	10.7 kPa (80 mmHg) or less		

2-2. Propulsion

Item	Standard value		Remarks
Travel speed (Forward/reverse)	SW types	0 to 12 km/h (0 to 7.5 mile/h)	
	TW types	0 to 11.7 km/h (0 to 7.3 mile/h)	

2-3. Hydraulic System

Item				Standard value		Remarks	
Propulsion	High pressure relief valve setting			34.5 ±1.0 MPa (5,003 ±145 psi)			
	Cut off valve setting			—			
	Charge relief valve setting			1.9 ± 0.07 MPa (275.5 ±10.2 psi)			
	Case pressure	Pump			0.3 MPa (43.5 psi)		
			Motor	SW types	Front	0.3 MPa (43.5 psi)	
				Rear			
		TW types	Front	0.3 MPa (43.5 psi)			
	Rear						
	Motor brake release pressure	SW types	Front	1.5 MPa (217.5 psi)	Difference pressure with case internal pressure		
			Rear				
		TW types	Front	1.5 MPa (217.5 psi)	Difference pressure with case internal pressure		
Rear							
Motor drainage	SW types	Front	3.8 L/min (1.0 gal./min)				
		Rear					
	TW types	Front	2.1 L/min (0.6 gal./min)				
		Rear					
Vibration	High pressure relief valve setting			12.7 ±0.5 MPa (1,842 ±72.5 psi)			
	Cut off valve setting			—			
	Charge relief valve setting			—			
	Case pressure	Pump			—		
		Motor			—		
Motor drainage			3.4 L/min (0.9 gal./min)				
Steering oil pressure			14.9 MPa (2,161 psi)		Orbitrol relief + charge relief		

2-4. Steering

Item				Standard value		Remarks
Play in steering wheel				5 to 10 mm (0.2 to 0.4 in.)	Steering wheel circumference	
				5 mm (0.02 in.) or less	Steering column shaft direction	

SPECIFICATIONS

2-5. Brakes

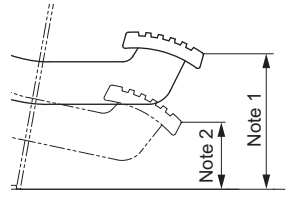
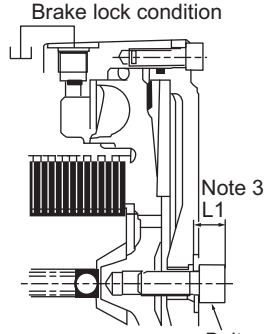
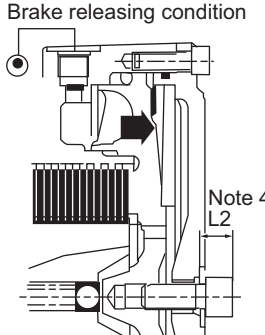
Item	Standard value	Remarks
Clearance between brake pedal and floorboard (as released)	102 mm (4.0 in.) Note 1: See dimensions	 <p>SW652-1-02001</p>
Clearance between brake pedal and floorboard (when pressed down)	53 mm (2.1 in.) Note 2: See dimensions	
Replacement standard brake stroke length	3.5 mm (0.14 in.) Note 3 and Note 4: See dimensions	<p>Brake lock condition</p>  <p>Note 3 L1 Bolt</p> <p>Brake releasing condition</p>  <p>Note 4 L2</p> <p>Brake stroke length = L2-L1 SW300-1-02001</p>

2-6. Capacities

Item	Standard value	Remarks
Engine oil pan	7.0 L (1.8 gal.)	
Fuel tank	SW types	50 L (13.2 gal.)
	TW types	43 L (11.3 gal.)
Coolant	7.0 L (1.8 gal.)	
Hydraulic oil tank	42 L (11.1 gal.)	
Vibrator case	SW300-1	2.5 L (0.7 gal.)
	SW/TW320-1	4.0 L (1.1 gal.)
	SW/TW330-1	4.8 L (1.3 gal.)
Water spray tank	180 L (47.6 gal.)	
Liquid spray tank	TW only	10 L (2.6 gal.)

3. FUEL AND LUBRICANTS SPECIFICATION

3-1. Rating

Lubricant	Service classification	Ambient temp. and applicable viscosity rating			Applicable Standards
		-15 to 30°C (5 to 86°F) Cold	0 to 40°C (32 to 104°F) Moderate	15 to 55°C (59 to 131°F) Tropical	
Engine oil	API grade CD	SAE10W-30	SAE30	SAE40	MIL-L-2104D
Gear oil	API grade GL4	SAE80W-90	SAE90	SAE140	MIL-L-2105
Hydraulic oil	Wear resistant	ISO-VG32 Over VI 140	ISO-VG46 Over VI 140	ISO-VG68 Over VI 110	ISO-3448
Grease	Lithium type extreme pressure				NLGI-2
Fuel	Diesel oil				ASTM D975-2D

3-2. Recommended Lubricants

Lubricant Oil company	Engine oil API-CC	Gear oil API GL 4	Hydraulic oil VG 46	Grease (NLGI-II)
CALTEX	RPM DELO 300 oil	Universal Thuban 90	Rando Oil HD 46	Martifack EP 2
BP	BP Vanellus C3-30	BP Gear Oil EP 90	BP Energol HLP 46	BP Energrease LS-EP 2
ESSO	Esso Lube D3-30	Esso Gear Oil GP 90	Nuto H 46	Beacon EP 2
MOBIL	Mobil Delvac 1330	Mobil Pegasus Gear oil 90	Nuto Oil 25	Beacon EP 25
SHELL	Shell Rotella CT Oil 30	Shell Spirax 90 EP	Shell Tellus Oil 46	Shell Alvania EP Grease 2
CASTROL	Castrol CRD 30	Castrol Hypoy 90	Hyspin AWS 46	Spherrol ELP 2

SPECIFICATIONS

4. TIGHTENING TORQUE CHART

N·m	(lbf·ft)
-----	----------

	Nominal Dia.	Pitch	Strength Classification							
			6.8		8.8		10.9		12.9	
Metric coarse screw	5	0.8	4.9	(3.6)	5.9	(4.4)	7.8	(5.8)	7.8	(5.8)
	6	1.0	7.8	(5.8)	9.8	(7.2)	13	(9.6)	13	(9.6)
	8	1.25	17	(13)	23	(17)	31	(23)	31	(23)
	10	1.5	39	(29)	49	(36)	59	(44)	59	(44)
	12	1.75	69	(51)	78	(58)	108	(80)	108	(80)
	14	2.0	98	(72)	127	(94)	167	(123)	167	(123)
	16	2.0	157	(116)	196	(145)	265	(195)	265	(195)
	18	2.5	196	(145)	245	(181)	343	(253)	343	(253)
	20	2.5	294	(217)	392	(289)	539	(398)	539	(398)
	22	2.5	441	(325)	539	(398)	686	(506)	686	(506)
	24	3.0	539	(398)	637	(470)	883	(651)	883	(651)
	27	3.0	785	(579)	981	(724)	1324	(977)	1324	(977)
30	3.5	1079	(796)	1324	(977)	1765	(1302)	1765	(1302)	
Metric fine screw	10	1.25	39	(29)	49	(36)	69	(51)	69	(51)
	12	1.25	69	(51)	88	(65)	118	(87)	118	(87)
	14	1.5	108	(80)	137	(101)	186	(137)	186	(137)
	16	1.5	167	(123)	206	(152)	284	(209)	284	(209)
	18	1.5	245	(181)	294	(217)	392	(289)	392	(289)
	20	1.5	343	(253)	441	(325)	588	(434)	588	(434)
	22	1.5	490	(361)	588	(434)	785	(579)	785	(579)
	24	2.0	588	(434)	735	(542)	981	(724)	981	(724)
	27	2.0	834	(615)	1030	(760)	1422	(1049)	1422	(1049)
	30	2.0	1177	(868)	1422	(1049)	1961	(1446)	1961	(1446)

ENGINE AND CONTROLS

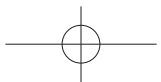
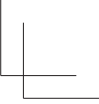
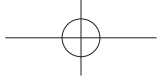

1. ENGINE

1-1. Engine Mount

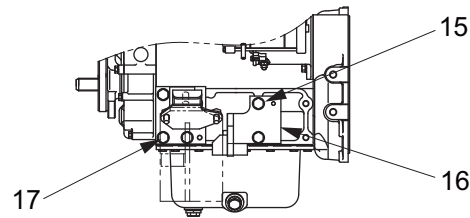
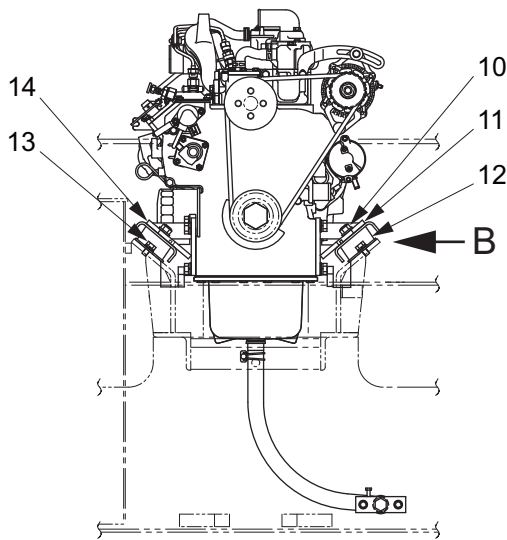
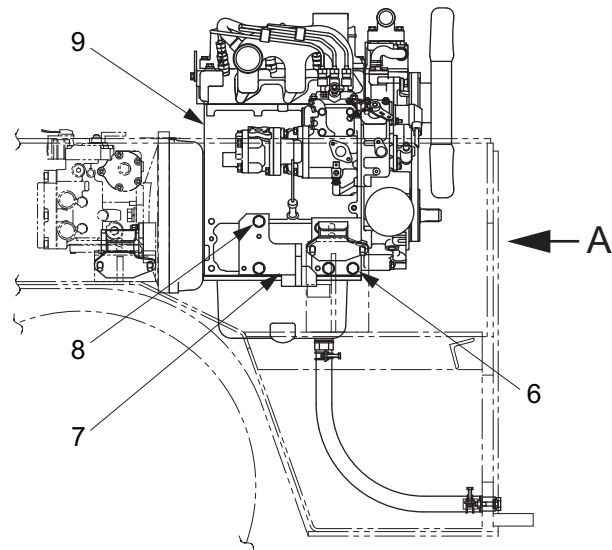
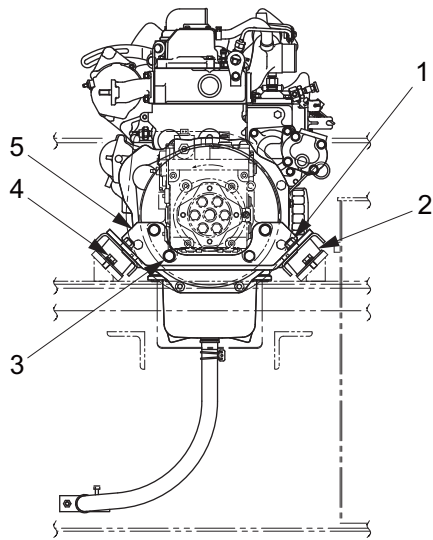

VIEW A

VIEW B

0445-01803-0-10600-A

- | | | |
|--------------------------|--------------------------|---------------------------|
| (1) Nut : M12 P=1.25 | (7) Stopper | (13) Bolt : M10×20 |
| (2) Rubber isolator | (8) Bolt : M12×30 P=1.25 | (14) Bracket |
| (3) Bolt : M12×30 | (9) Engine | (15) Bolt : M12×30 P=1.25 |
| (4) Bolt : M10×20 | (10) Nut : M12 P=1.25 | (16) Stopper |
| (5) Bracket | (11) Bracket | (17) Bolt : M12×30 P=1.25 |
| (6) Bolt : M12×30 P=1.25 | (12) Rubber isolator | |



- | | |
|--|---|
| (1) Nut M12 P=1.25: 88 N·m (65 lbf·ft) | (10) Nut M12 P=1.25: 88 N·m (65 lbf·ft) |
| (3) Bolt M12×30 78 N·m (58 lbf·ft) | (13) Bolt M10×20 49 N·m (36 lbf·ft) |
| (4) Bolt M10×20 49 N·m (36 lbf·ft) | (15) Bolt M12×30 P=1.25: 88 N·m (65 lbf·ft) |
| (6) Bolt M12×30 P=1.25: 88 N·m (65 lbf·ft) | (17) Bolt M12×30 P=1.25: 88 N·m (65 lbf·ft) |
| (8) Bolt M12×30 P=1.25: 88 N·m (65 lbf·ft) | |

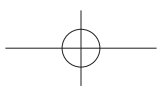
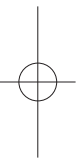
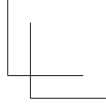
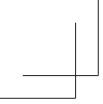

1-2. Engine Exterior

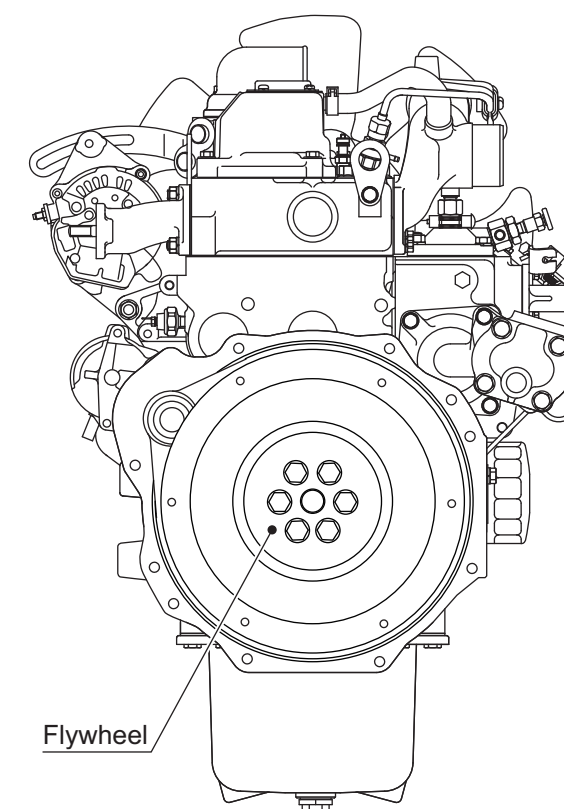
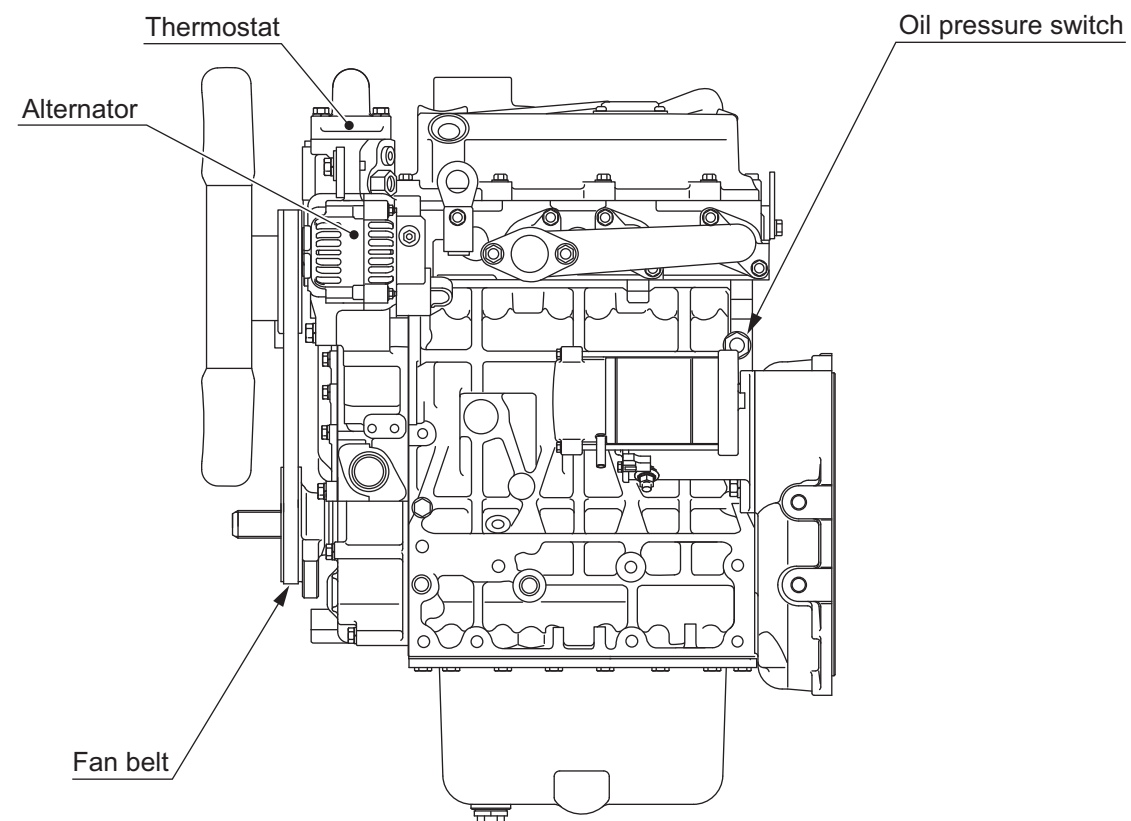
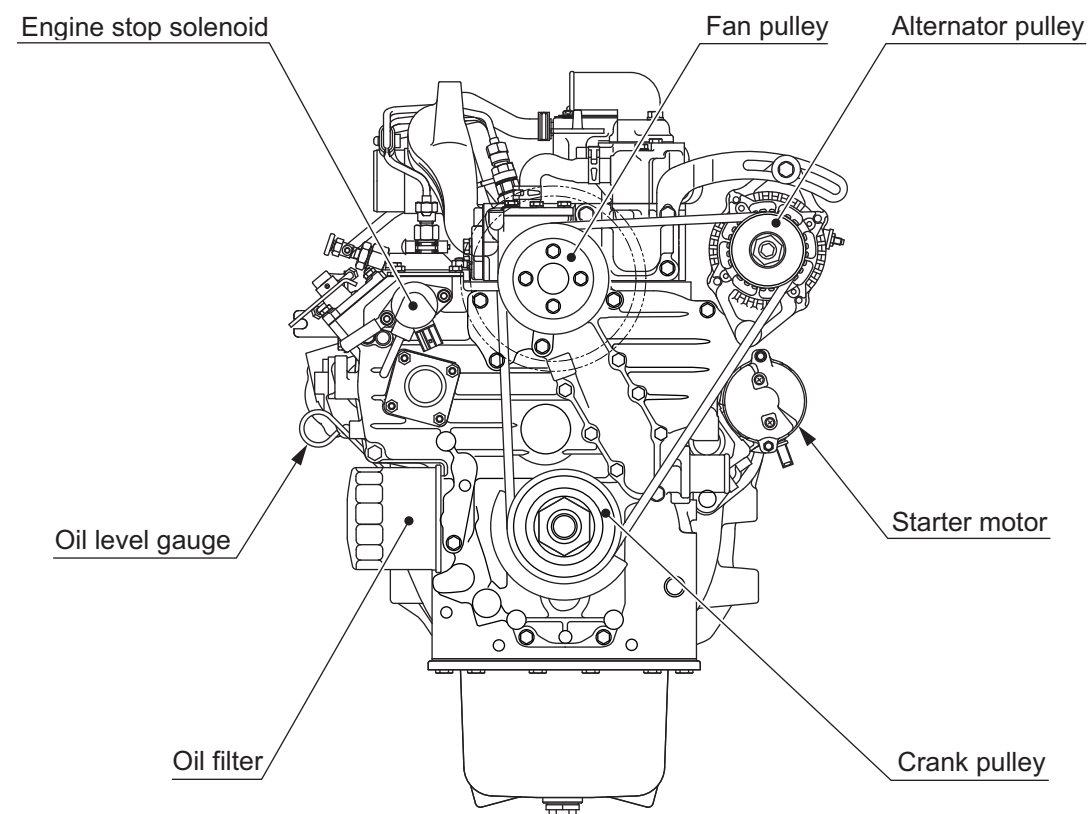
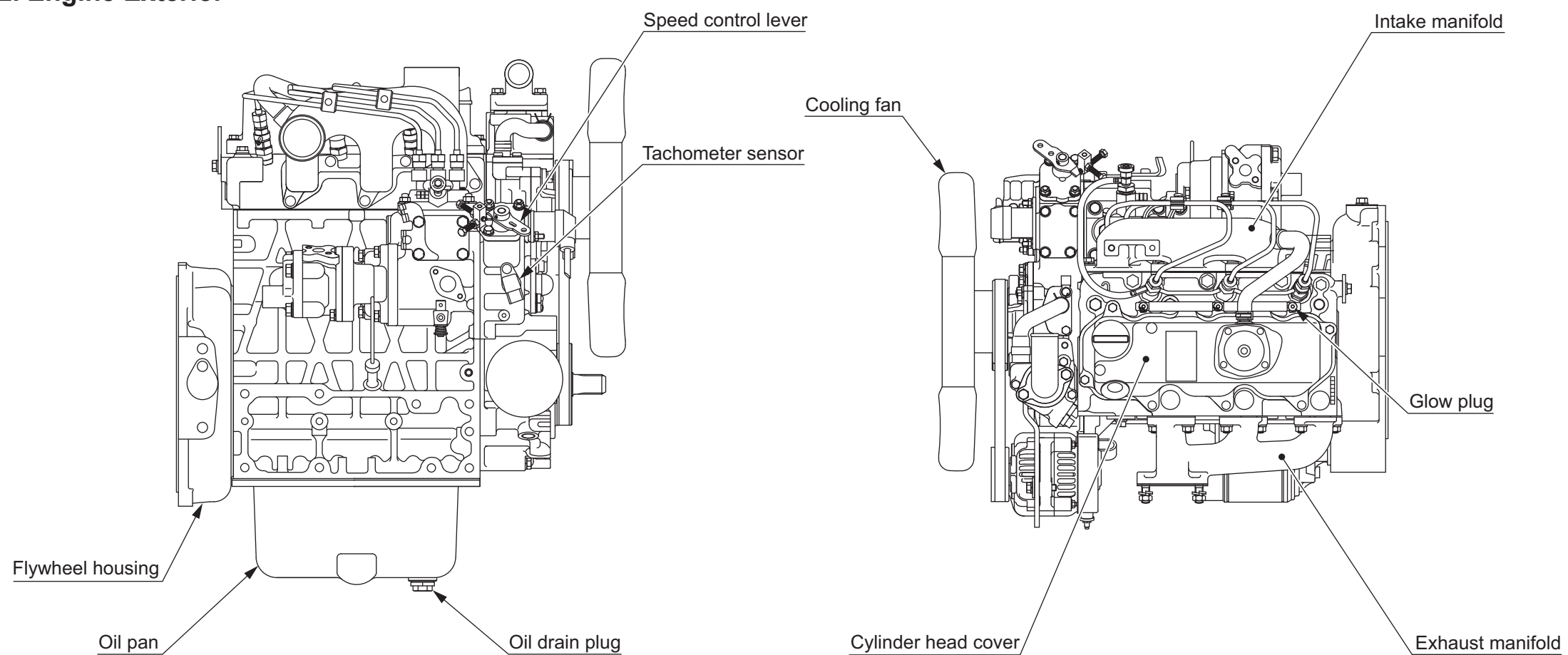

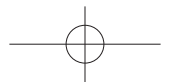
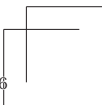
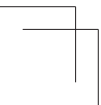
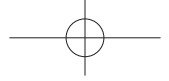
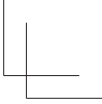
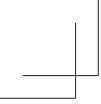

2. CONTROL SYSTEM

2-1. Throttle Control

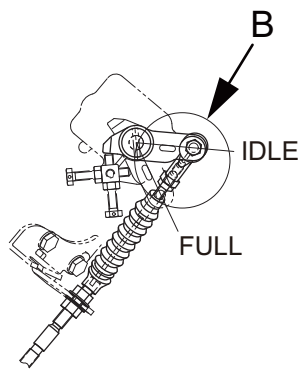
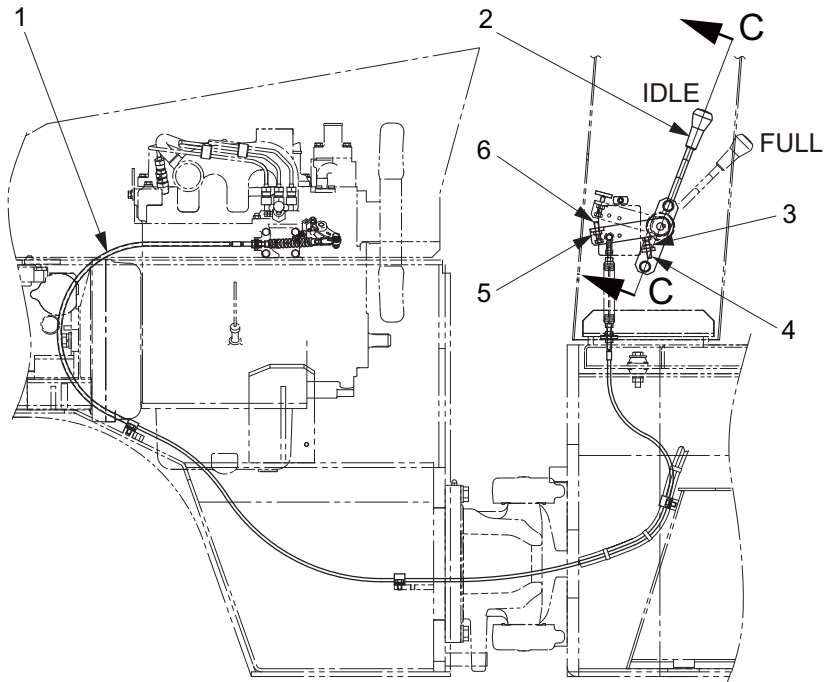
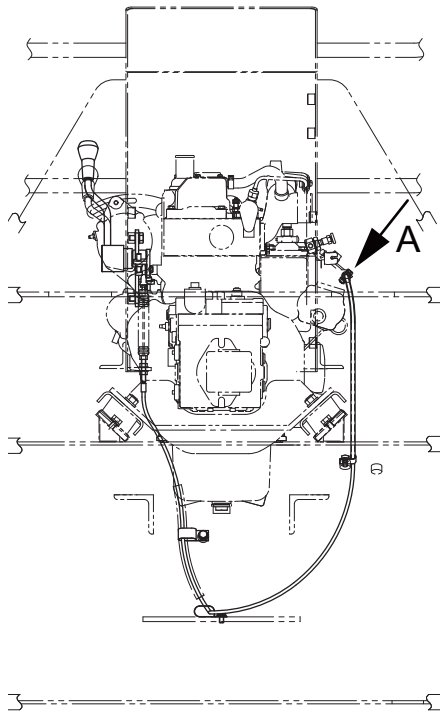

VIEW A

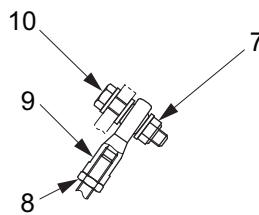

DETAIL B
(Control cable both sides)

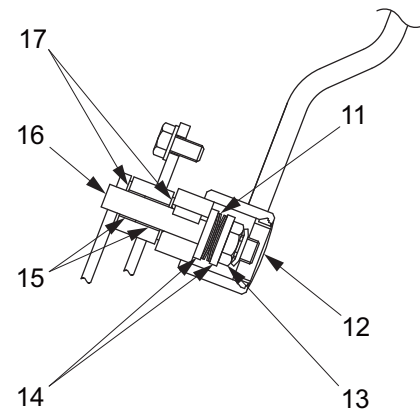

SECTION C-C

0445-12805-0-10682-B

- (1) Control cable
- (2) Throttle lever
- (3) Lock nut : M 8
- (4) Stopper bolt (IDLE) : M 8×35
- (5) Lock nut : M 8
- (6) Stopper bolt (FULL) : M 8×35
- (7) Nut : M 6
- (8) Nut : M 6
- (9) Rod end (Apply grease)

- (10) Bolt : M 6×30
- (11) Disc spring
- (12) Plug
- (13) Nut : M14
- (14) Washer
- (15) Bush
- (16) Shaft
- (17) Washer (Apply grease)

2-2. Forward-reverse Control

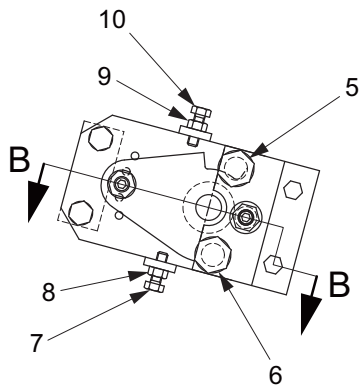
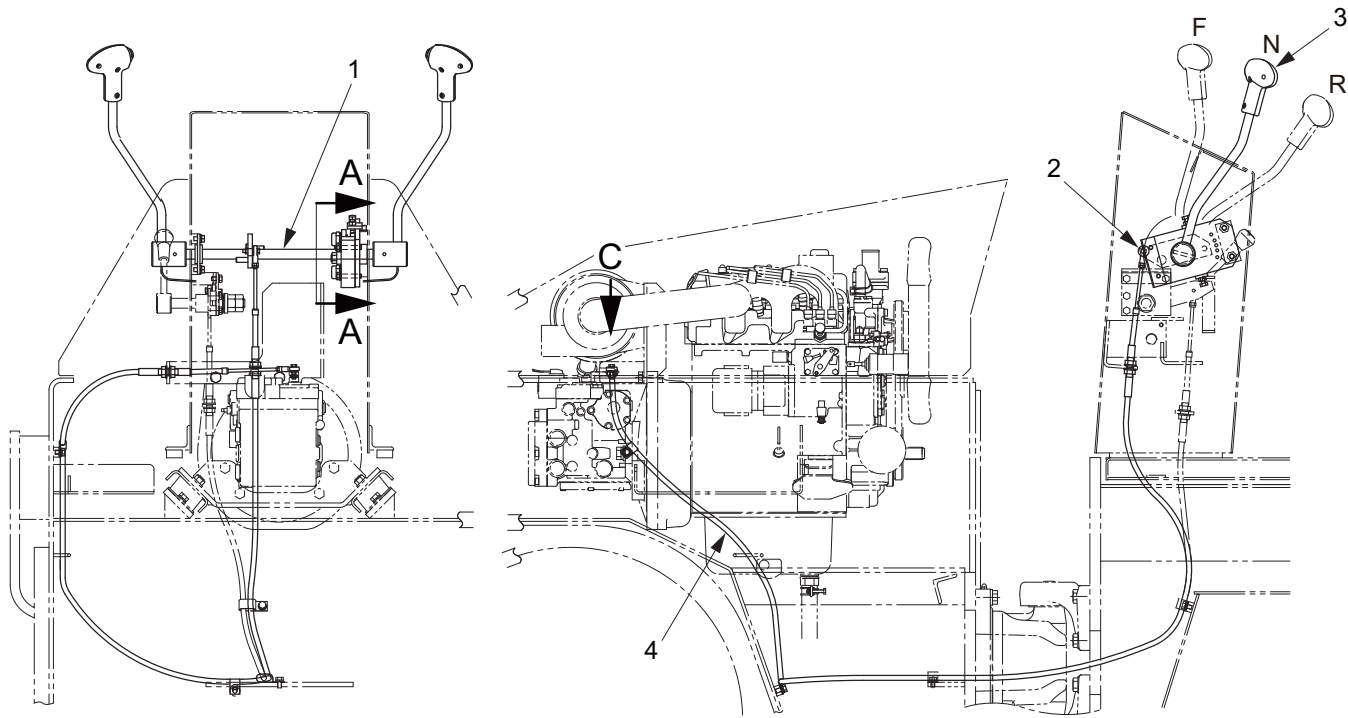

SECTION A-A

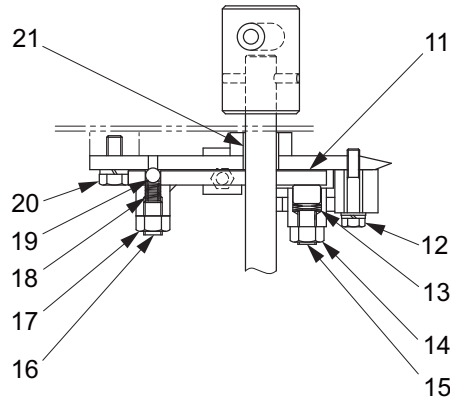

SECTION B-B

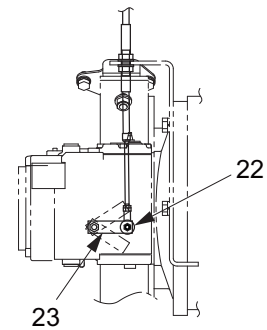

VIEW C

0445-12806-0-10683-A

- | | | |
|-------------------------------------|--------------------------------------|----------------------------|
| (1) Shaft | (9) Lock nut : M 8 | (17) Lock nut : M12 |
| (2) Rod end | (10) Stopper bolt (forward) : M 8×25 | (18) Spring (Fill grease*) |
| (3) F-R lever | (11) Friction plate | (19) Steel ball |
| (4) Control cable | (12) Bolt : M 8×45 | (20) Bolt : M 8×25 |
| (5) Backup buzzer switch | (13) Disc spring (Apply grease*) | (21) Bush |
| (6) F-R lever switch | (14) Lock nut : M12 | (22) Rod end |
| (7) Stopper bolt (reverse) : M 8×25 | (15) Set screw : M12×22 | (23) Pump lever |
| (8) Lock nut : M 8 | (16) Set screw : M12×22 | |

* : Lithium-based grease

3. PUMP MOUNT

3-1. Pump Mount

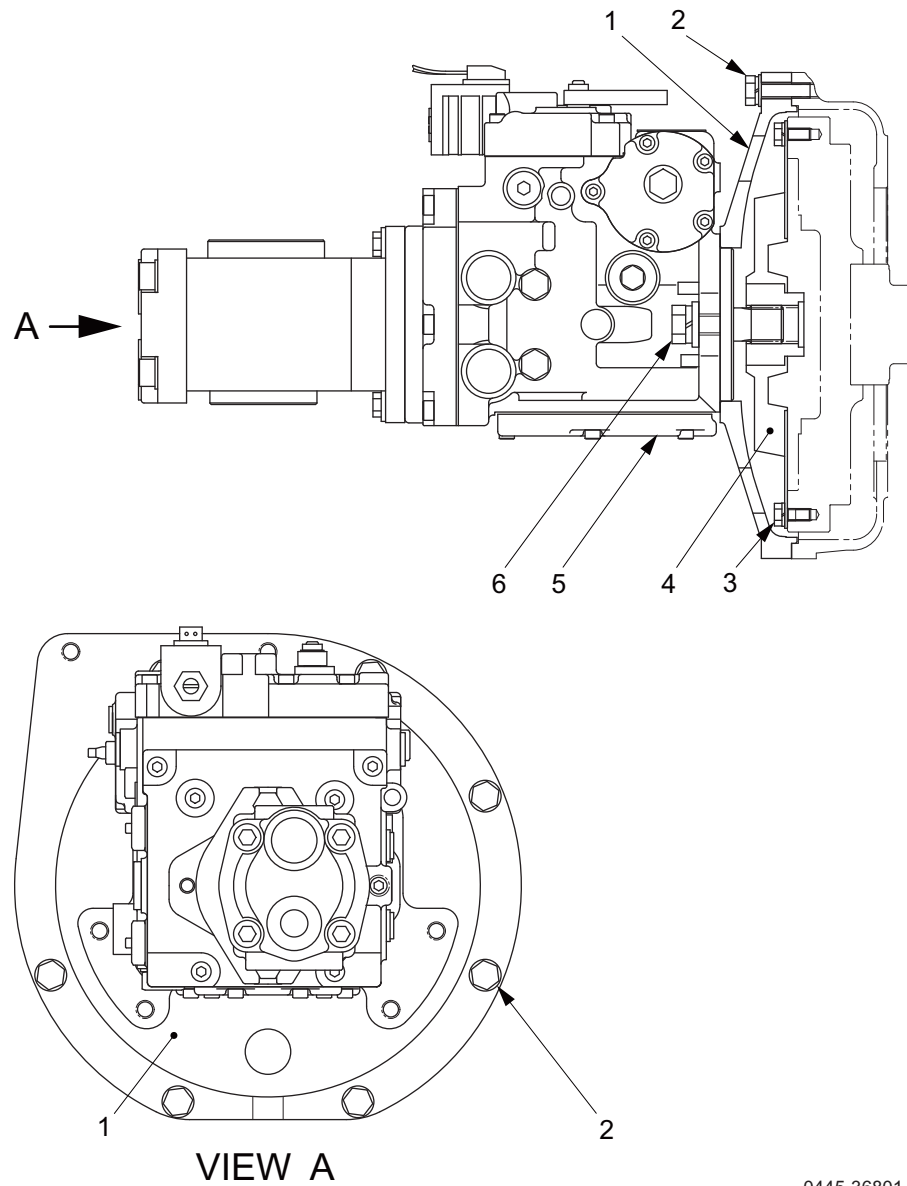

0445-36801-0-20029-B

- | | |
|--------------------------|-------------------|
| (1) Cover | (4) Coupling |
| (2) Bolt : M10×40 P=1.25 | (5) Pump |
| (3) Bolt : M 8×20 | (6) Bolt : M14×40 |



- | | |
|------------------------|--------------------------|
| (2) Bolt M10×40 P=1.25 | : 49 N·m (36 lbf·ft) |
| (3) Bolt M 8×20 | : 17 N·m (13 lbf·ft) |
| (6) Bolt M14×40 | : 167 N·m (123 lbf·ft) |

ENGINE AND CONTROLS

3-1-1. Installation of pump

- When the pump has been removed from the engine for repair or replacement, reinstall it in accordance with the following procedure.

- ① Apply adequate amount of lithium-based grease to pump (5) and coupling (4) splines.
- ② Secure coupling (4) to engine flywheel with six bolts (3) and spring washers.

 (3) Bolt M 8×20 : 17 N·m (13 lbf·ft)

- ③ Secure housing (1) to pump (5) with two bolts (6), spring washers and washers.

(NOTICE)

- When secure housing (1), it is cautious of attachment position.

 (6) Bolt M14×40 : 167 N·m (123 lbf·ft)

- ④ Spline of pump subassembly is united with spline of coupling and then secure pump subassembly to flywheel housing with seven bolts (2), spring washers and washers.

(NOTICE)

- When secure pump subassembly, it is cautious of attachment position.

 (2) Bolt M10×40 P=1.25 : 49 N·m (36 lbf·ft)

(NOTICE)

- Bolts (3) are treated with thread-locking fluid. Use new thread-locking fluid treated bolts for installation.

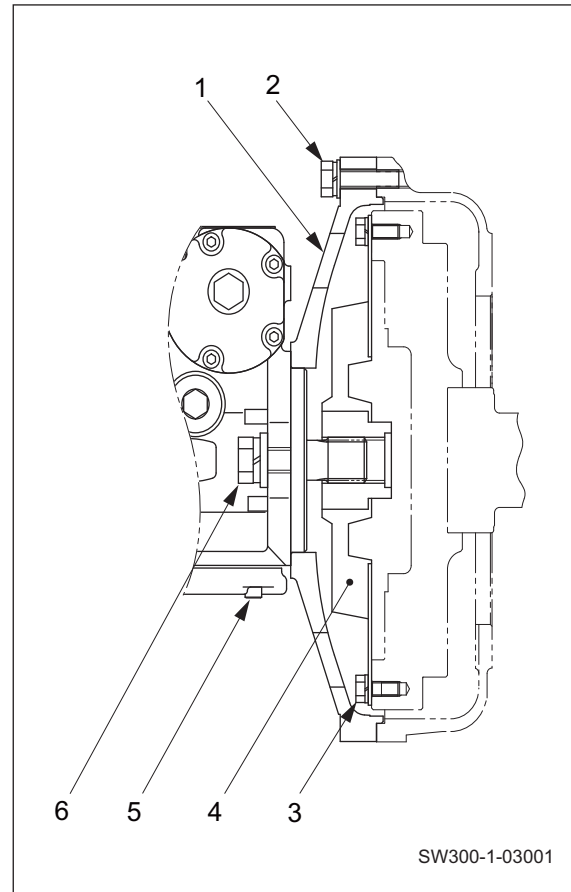

HYDRAULIC SYSTEMS

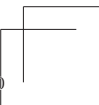
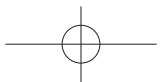
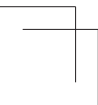
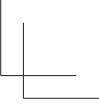
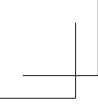

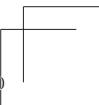
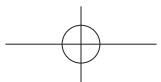
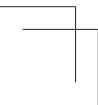
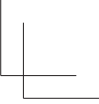
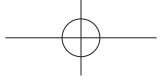

1. SYSTEM CIRCUIT DIAGRAM

1-1. Graphic Symbols for Hydraulic Circuits

Basic Symbols

DESCRIPTION	SYMBOL
Lines:	
Main working	
Pilot control	
Drain or bleed	
Lines, joining	
Not connected	
Component outline	
Arrow indicates direction of flow.	
Line with fixed restriction (orifice).	
Test port, pressure measurement.	
Temperature measurement gauge	
Pressure measurement gauge	
Reservoir (vented)	
Filter or strainer	
Heat exchanger, lines indicate flow of coolant.	
Quick disconnect: Connected with mechanically opened checks. Disconnected.	
Sloping arrow through a symbol at 45° indicates that a component can be adjusted or varied.	

Pump, Motors and Cylinders

DESCRIPTION	SYMBOL
Hydraulic pumps:	
Fixed displacement	
Unidirectional	
Bidirectional	
Variable displacement	
Unidirectional	
Bidirectional	
Variable displacement pressure compensated Unidirectional	
Hydraulic Motor:	
Unidirectional	
Bidirectional	
Double acting hydraulic cylinder	
Differential cylinder	
Electric motor	

Valves

DESCRIPTION	SYMBOL
Check valve	
Manual shut off (On-Off)	
Pressure relief	
Flow control, adjustable	
Valve symbols: The basic valve symbol one or more squares with lines representing flow paths and flow conditions between ports.	
Multiple squares indicate a valve with as many distinct positions there are squares providing various flow path options for the fluid. The multiple square moves to represent how flow paths change when the valving element is shifted within the component.	
Valves with infinite positioning between certain limits are symbolized with lines parallel to the squares.	

Methods of Operation

DESCRIPTION	SYMBOL
Spring	
Manual	
Pressure compensated	
Reversing motor	
Pilot pressure: Internal supply	
Remote supply	
Solenoid: Single winding	
Two windings operating in opposite directions.	
Pilot directional valve is actuated by the solenoid.	

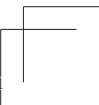
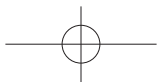
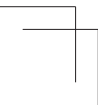
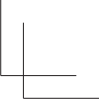

1-2. Hydraulic Circuit Diagram

1-2-1. Hydraulic circuit diagram (SW types)

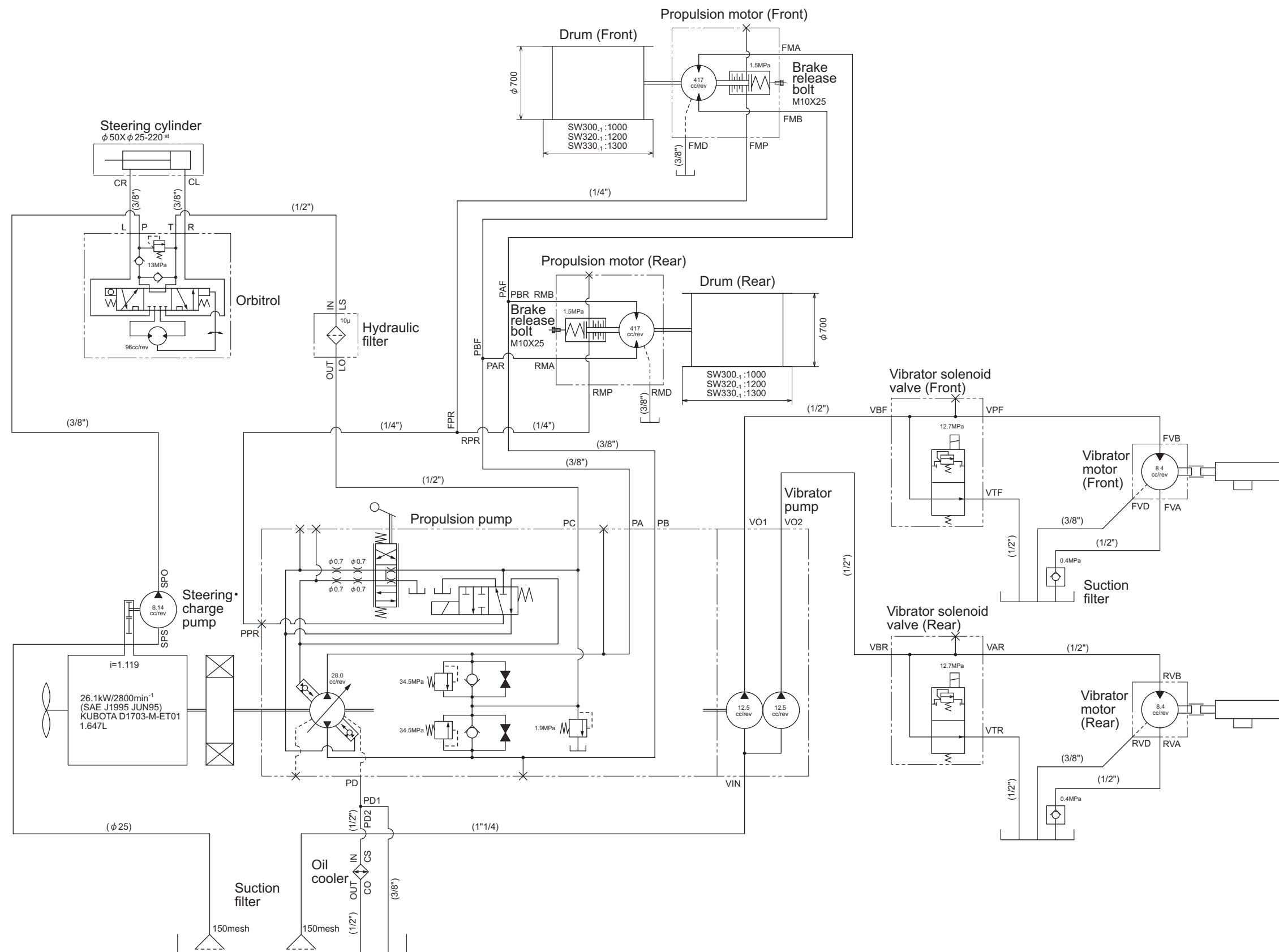

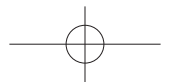
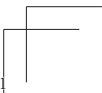
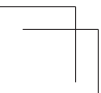

1-2-2. Hydraulic circuit diagram (TW types)

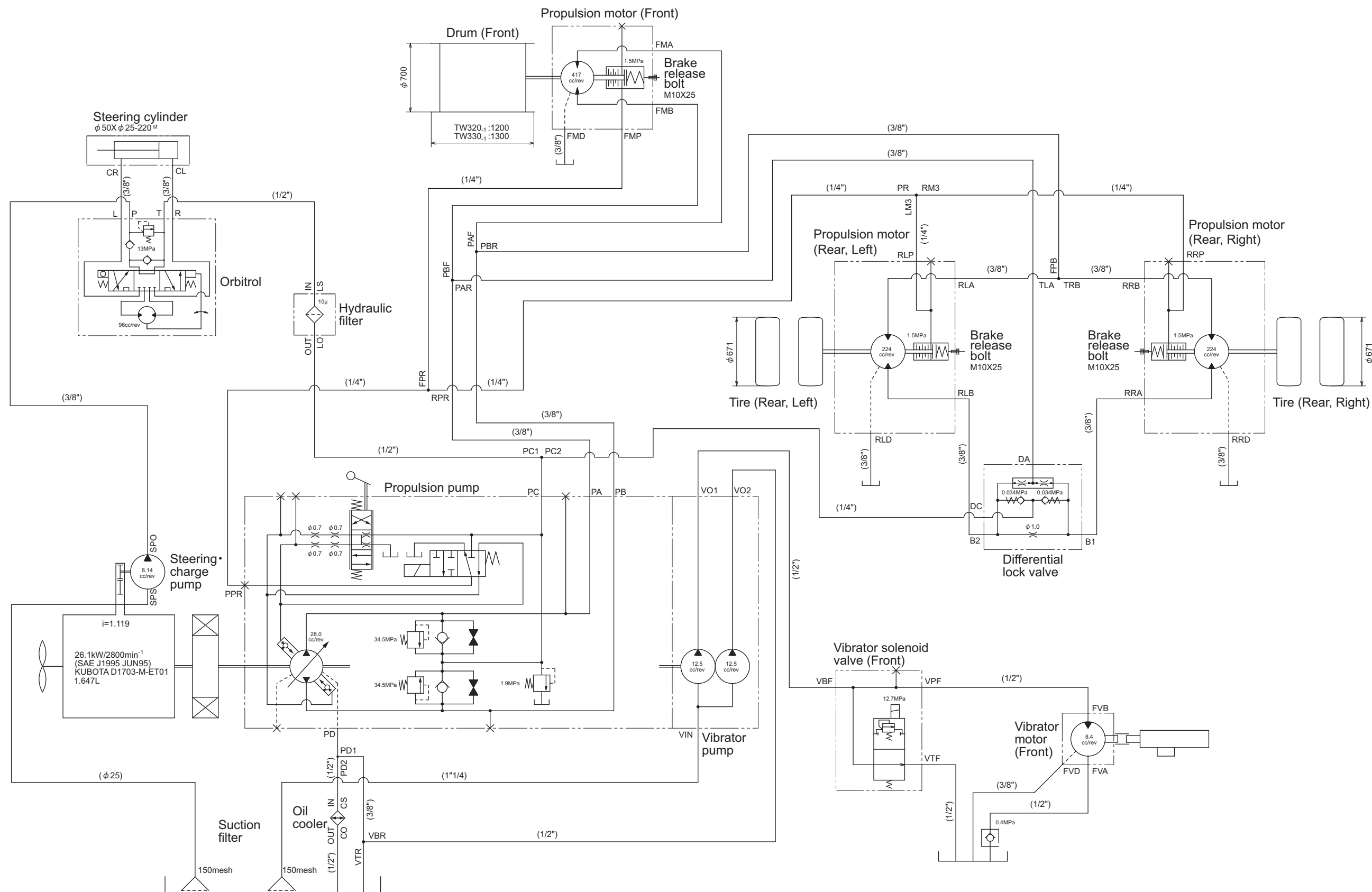

0425-99003-0-10033-A

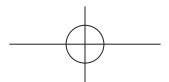
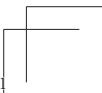
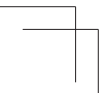

2. PROPULSION HYDRAULIC SYSTEM

2-1. Propulsion Hydraulic Piping

2-1-1. Propulsion hydraulic piping (1) (SW types: main)

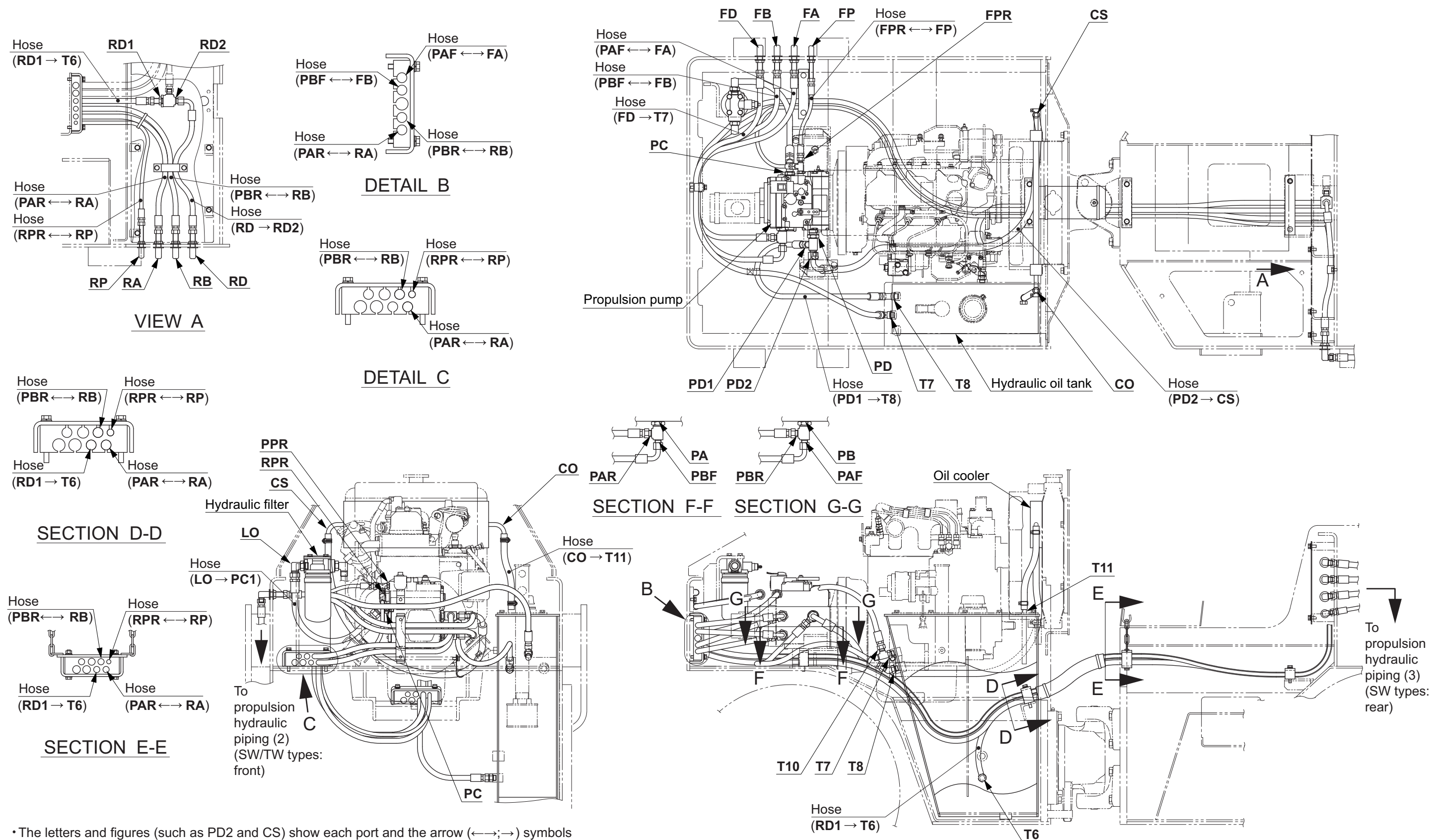

• The letters and figures (such as PD2 and CS) show each port and the arrow (↔; →) symbols show the hose connection and the direction of the flow of the oil.

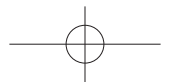
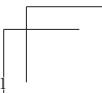
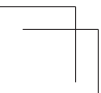
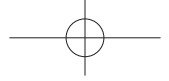

2-1-2. Propulsion hydraulic piping (1) (TW types: main)

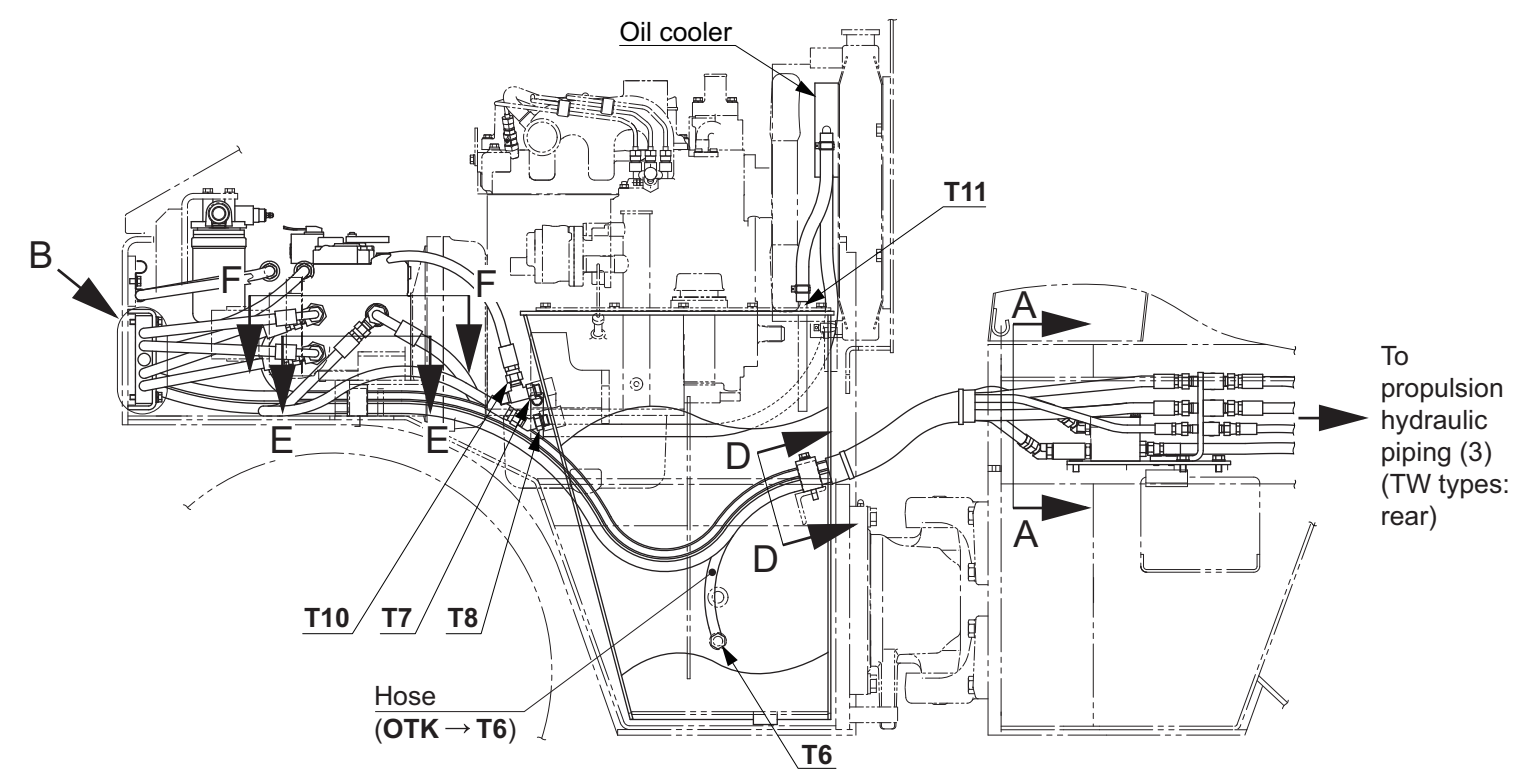
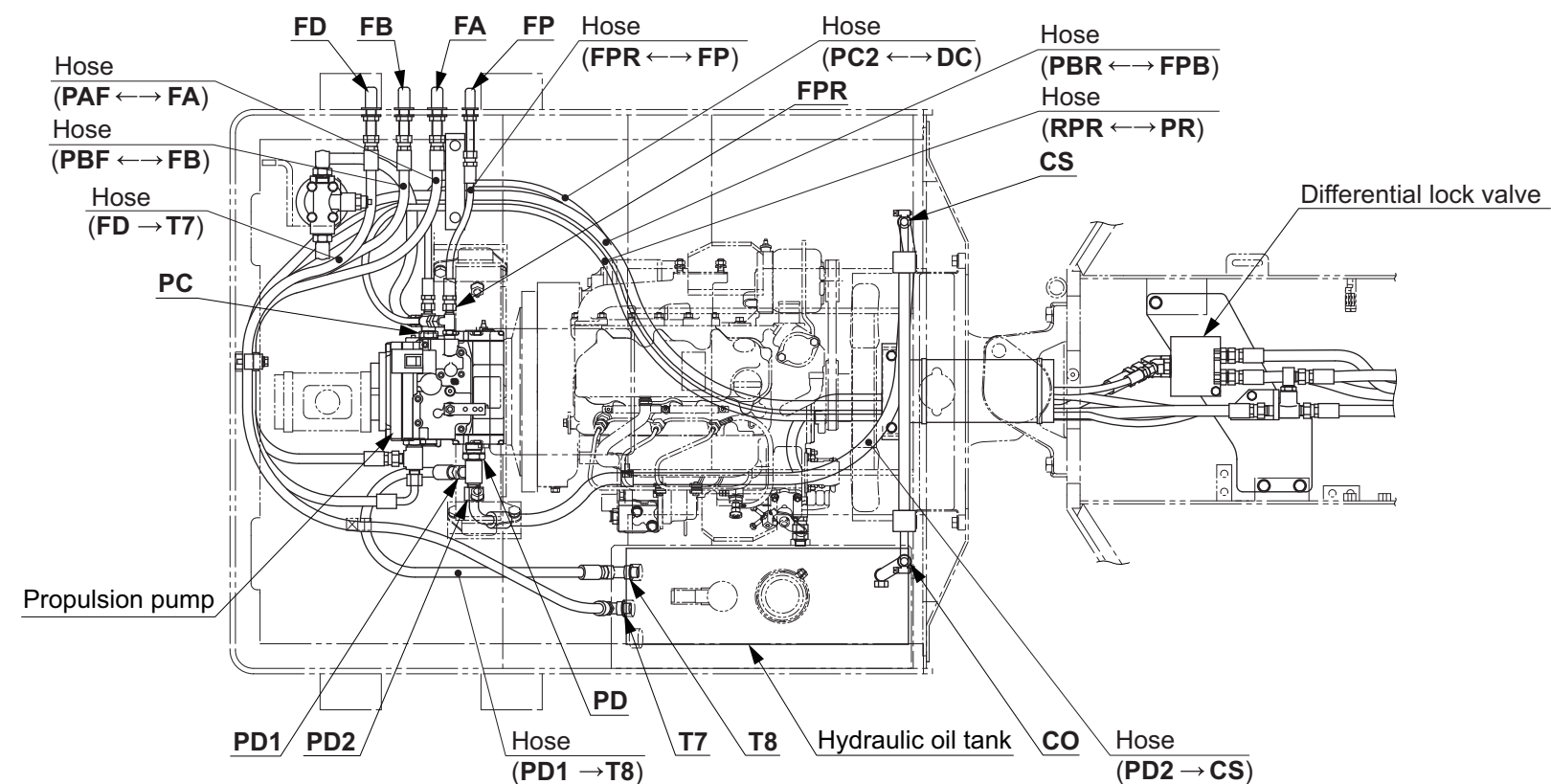
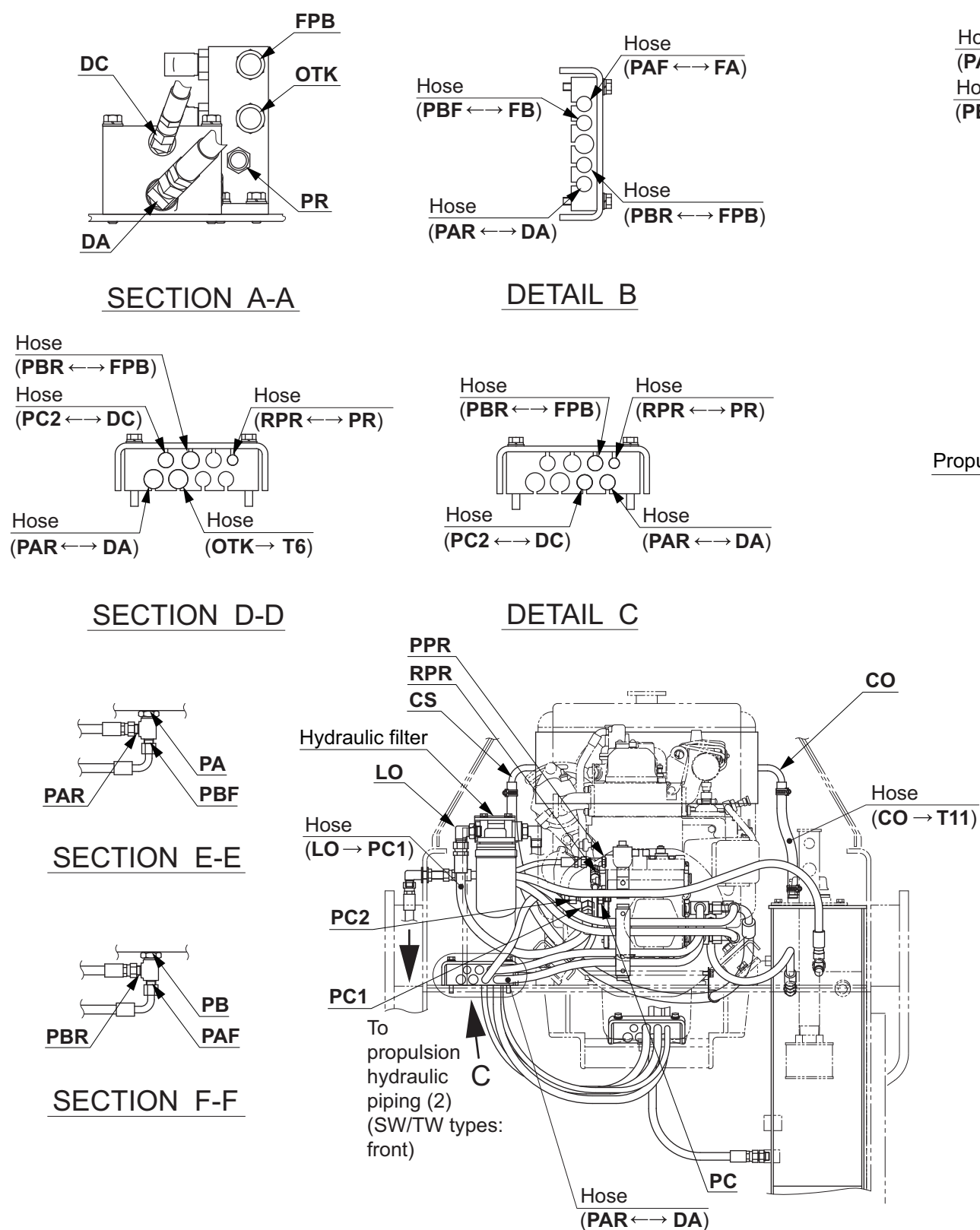

• The letters and figures (such as PD2 and CS) show each port and the arrow (↔; →) symbols show the hose connection and the direction of the flow of the oil.

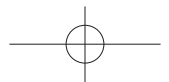
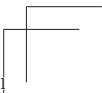
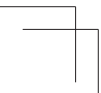

2-1-3. Propulsion hydraulic piping (2) (SW/TW types: front)

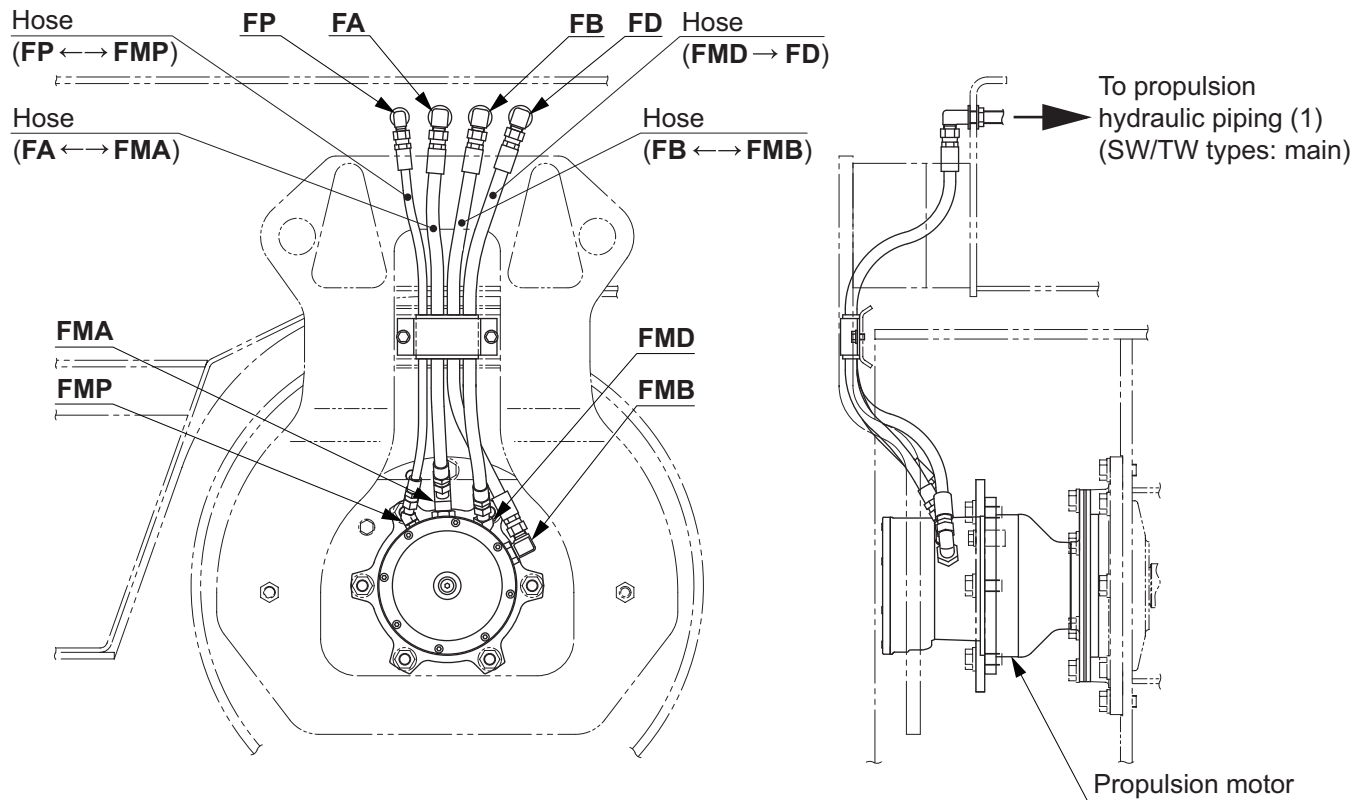

- The letters and figures (such as FP and FMP) show each port and the arrow (↔; →) symbols show the hose connection and the direction of the flow of the oil.

0445-36831-0-10067-Cf

HYDRAULIC SYSTEMS

2-1-4. Propulsion hydraulic piping (3) (SW types: rear)

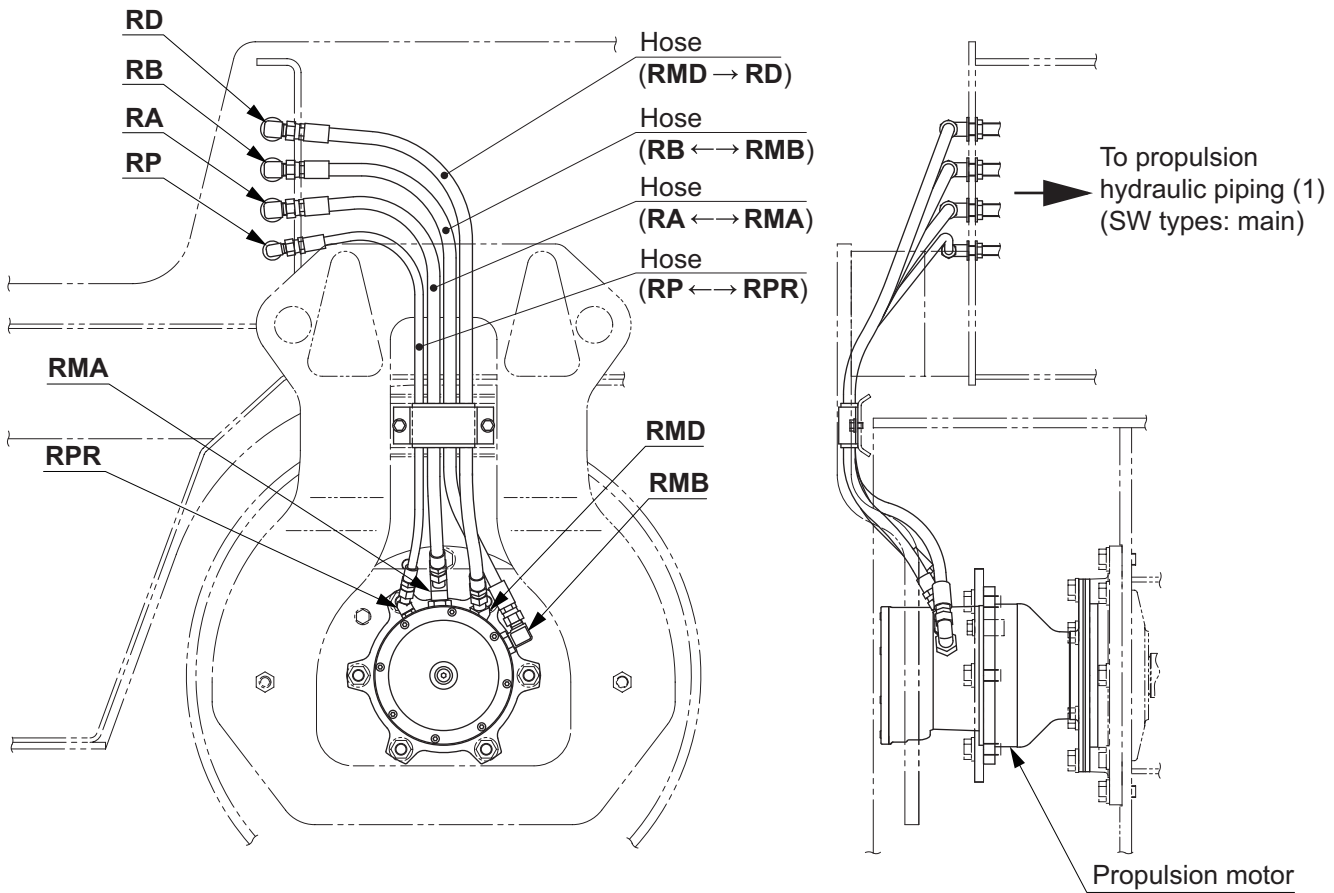

• The letters and figures (such as RMD and RD) show each port and the arrow (↔; →) symbols show the hose connection and the direction of the flow of the oil.

0445-36831-0-10067-Cr

2-1-5. Propulsion hydraulic piping (3) (TW types: rear)

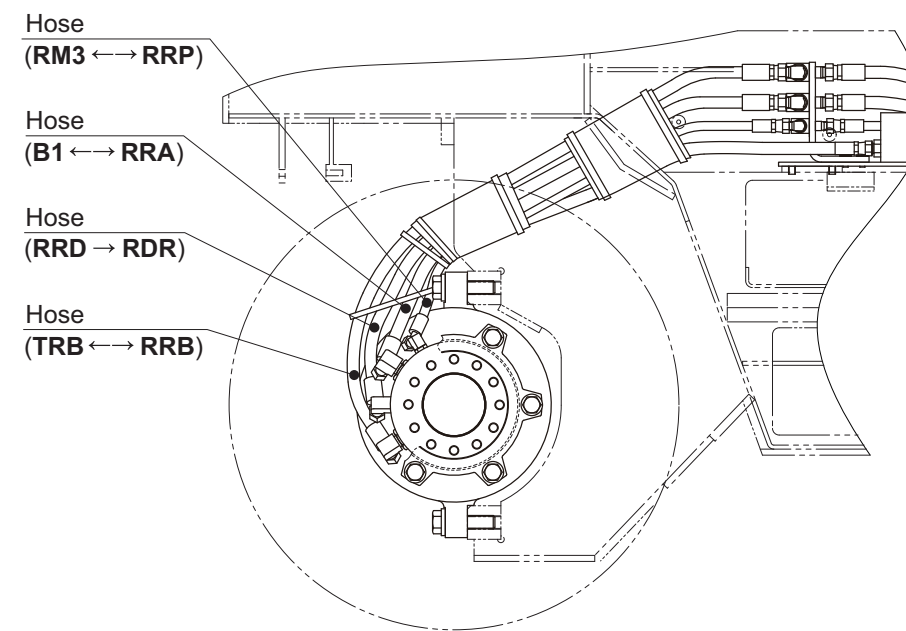
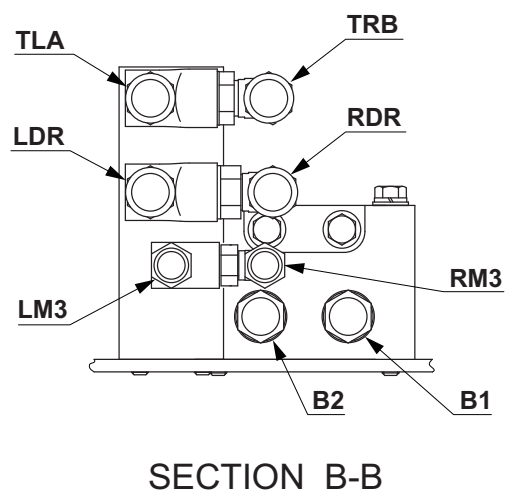
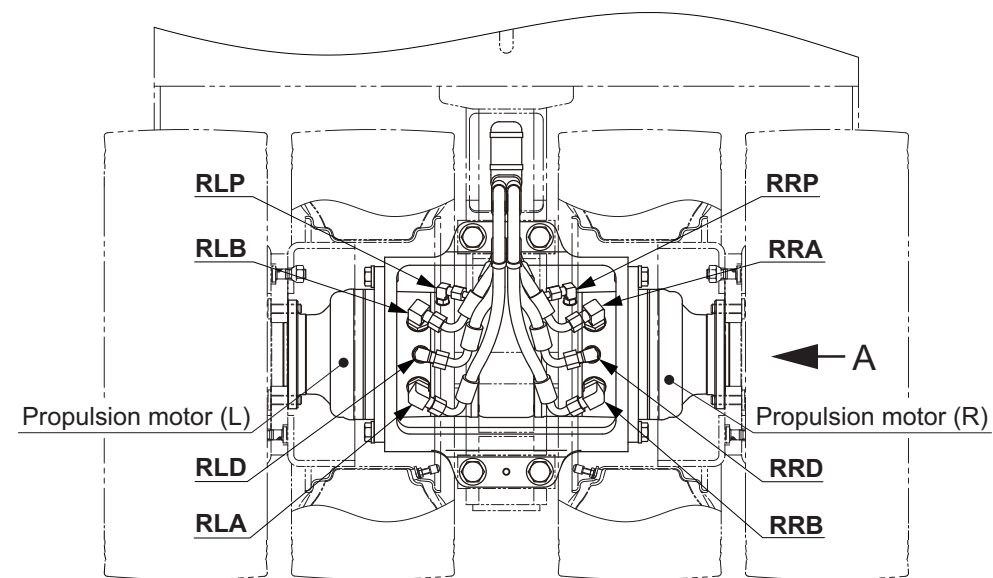
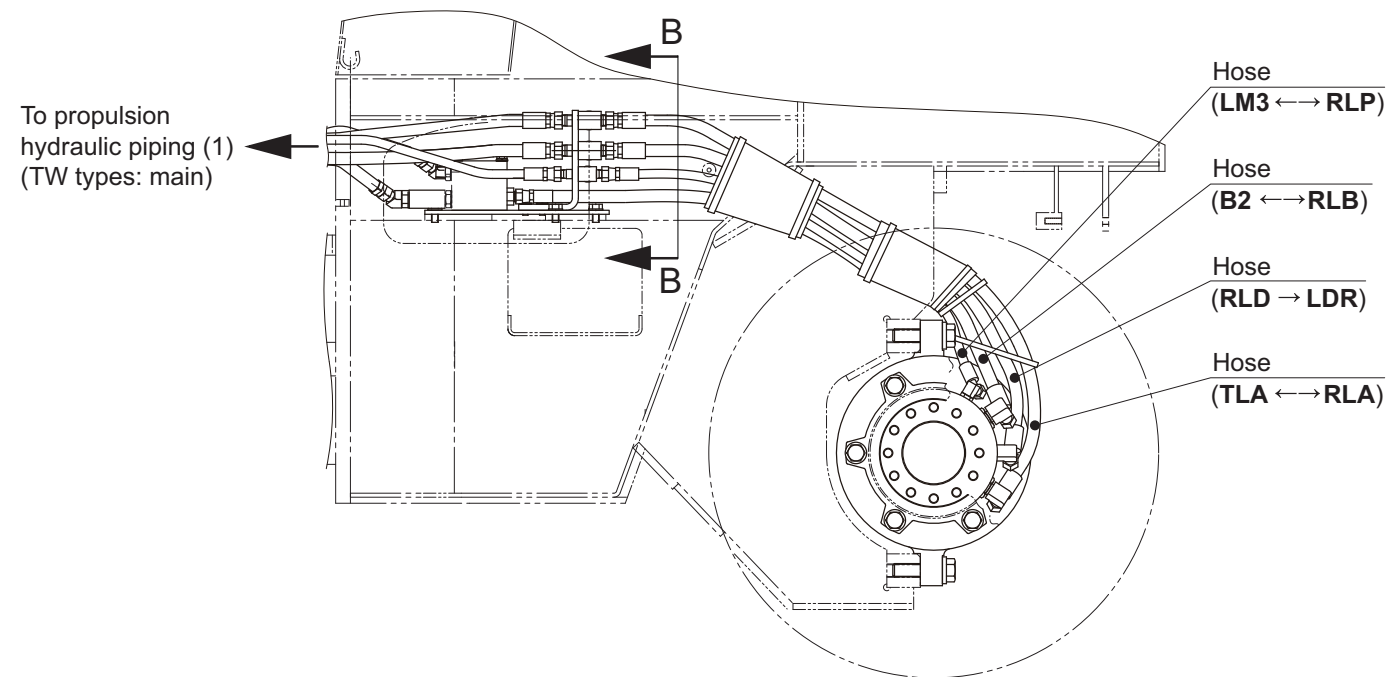

The letters and figures (such as RLD and LDR) show each port and the arrow (↔; →) symbols show the hose connection and the direction of the flow of the oil.

0425-36801-0-10009-0r

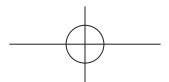
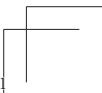
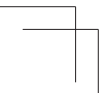

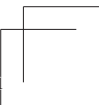
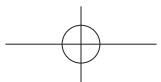
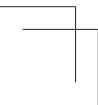
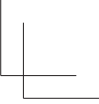
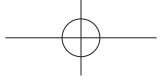

2-2. Hydraulic Component Specifications

2-2-1. Propulsion pump

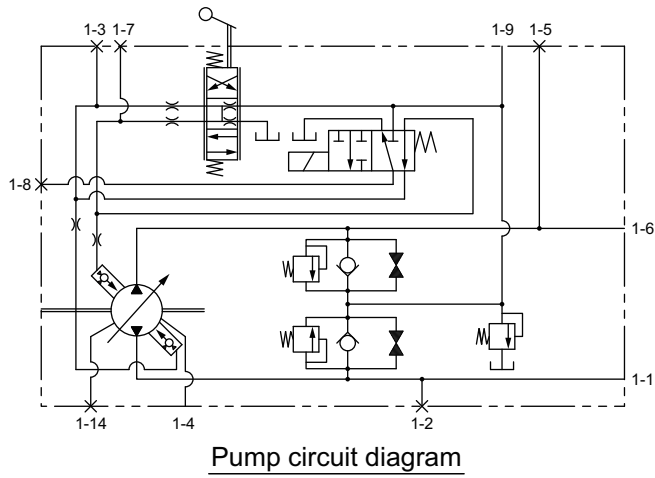
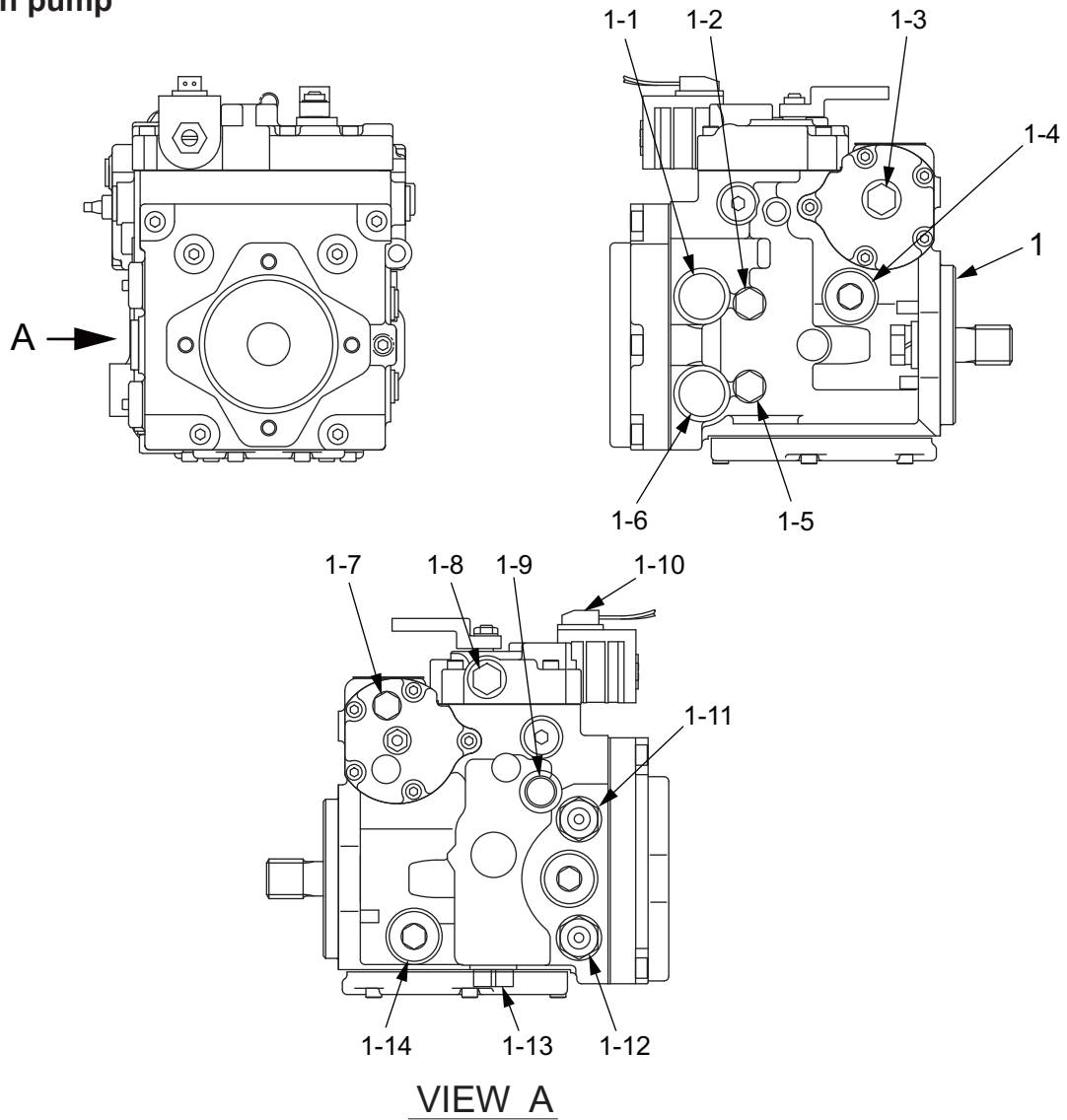

SW300-1-04005

(1) Propulsion pump

(1-1)	Port B (Reverse)	[PB]	: 1 1/16-12UN
(1-2)	High pressure gauge port (For port B)		: 9/16-18UNF
(1-3)	Servo pressure gauge port		: 9/16-18UNF
(1-4)	Drain port	[PD]	: 1 1/16-12UN
(1-5)	High pressure gauge port (For port A)		: 9/16-18UNF
(1-6)	Port A (Forward)	[PA]	: 1 1/16-12UN
(1-7)	Servo pressure gauge port		: 9/16-18UNF
(1-8)	Brake release pressure port	[PPR]	: 9/16-18UNF
(1-9)	Charge supply port	[PC]	: 3/4-16UNF
(1-10)	Solenoid valve		
(1-11)	* High pressure relief and bypass valves		
(1-12)	* High pressure relief and bypass valves		
(1-13)	Charge relief valve		
(1-14)	Drain port		: 1 1/16-12UN

Specifications

- Displacement : 28 cm³/rev (1.7 cu.in./rev)
- High pressure relief valve pressure setting : 34.5 MPa (5,003 psi) (at 3.8 to 5.6 L/min)
- Charge relief valve pressure setting : 1.9 ± 0.07 MPa (276 ± 10.2 psi) (at 20 L/min)
- Allowable pump case pressure : 0.25 MPa (36.3 psi)
- Weight : 34.5 kg (76.1 lbs.)

* : High pressure relief and bypass valves = S.C.R. (System Check Relief) valve for charge check and high pressure relief and bypass valve.

2-2-2. Propulsion hydraulic motor (SW types: front and rear, TW types: front)

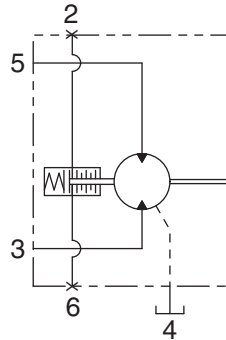
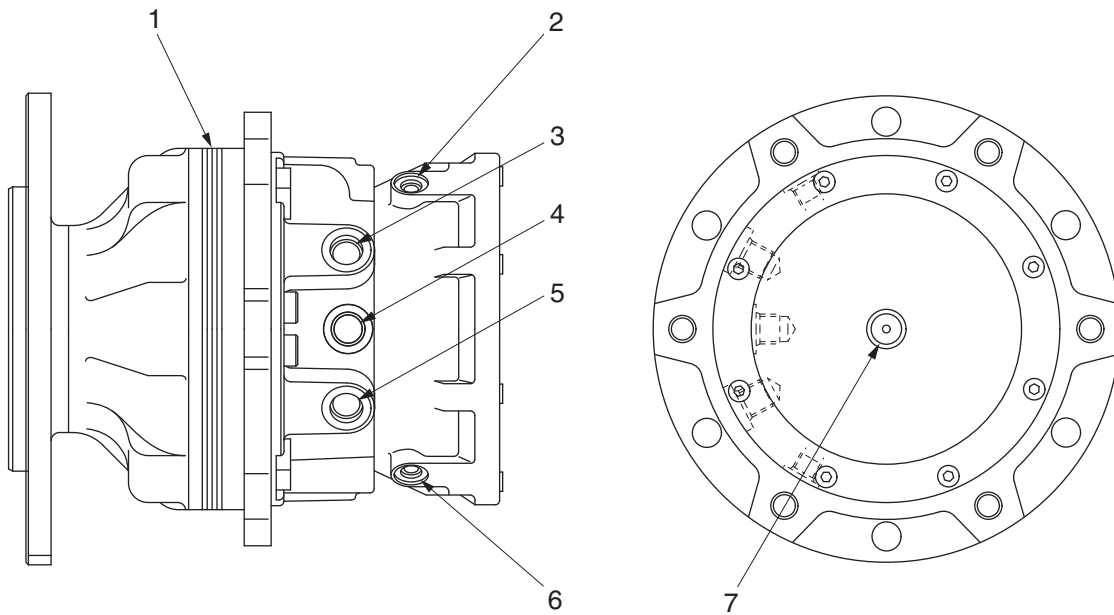

Motor circuit diagram

SW300-1-04001

- | | | | |
|------------------------------|---------------------------|-------------------------------|---------------------------|
| (1) Motor | | (5) Port A | [FMA] [RMA] : G1/2 |
| (2) Parking brake pilot port | : G1/4 | (6) Parking brake pilot port | [FMP] [RMP] : G1/4 |
| (3) Port B | [FMB] [RMB] : G1/2 | (7) Manual brake release port | |
| (4) Drain port | [FMD] [RMD] : G3/8 | | |

Motor specifications

- Displacement : 417 cm³/rev (25 cu.in./rev)
- Maximum working pressure : 34.3 MPa (4,974 psi)
- Allowable motor case pressure : 0.3 MPa (43.5 psi)
- Brake release pressure : 1.5 MPa (218 psi)
- Weight : 42 kg (93 lbs.)

2-2-3. Propulsion hydraulic motor (TW types: rear)

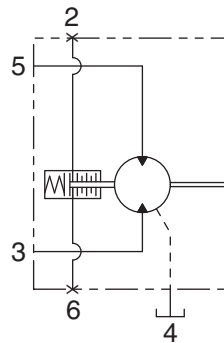
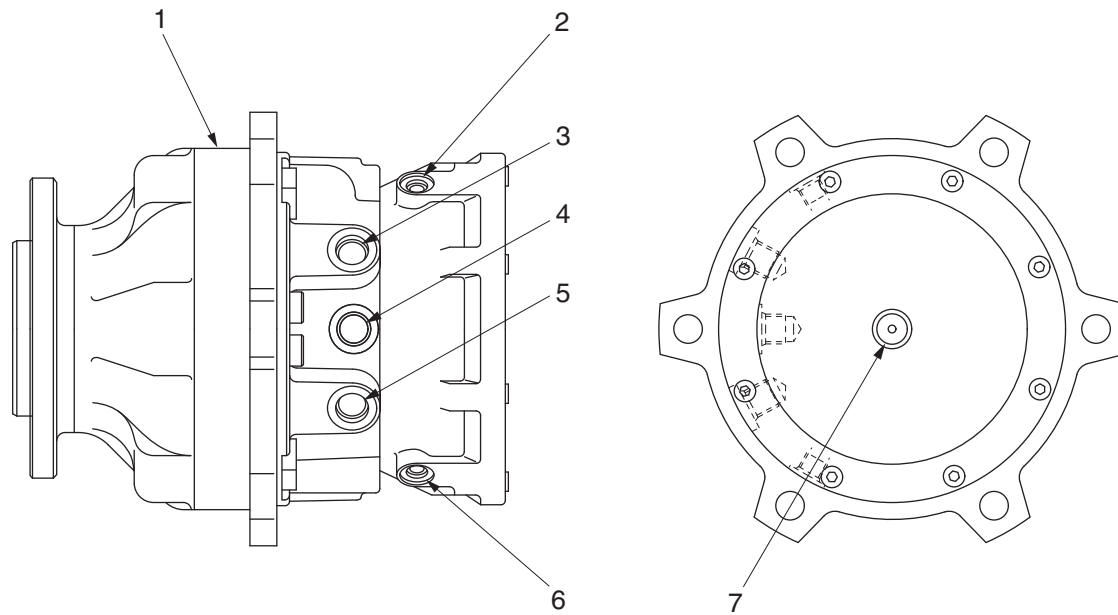

Motor circuit diagram

SW300-1-04006

- | | | | |
|------------------------------|---------------------------|-------------------------------|---------------------------|
| (1) Motor | | (5) Port A | [RLA] [RRA] : G1/2 |
| (2) Parking brake pilot port | [RLP] : G1/4 | (6) Parking brake pilot port | [RRP] : G1/4 |
| (3) Port B | [RLB] [RRB] : G1/2 | (7) Manual brake release port | |
| (4) Drain port | [RLD] [RRD] : G3/8 | | |

Motor specifications

- Displacement : 224 cm³/rev (14 cu.in./rev)
- Maximum working pressure : 41.2 MPa (5,974 psi)
- Allowable motor case pressure : 0.3 MPa (43.5 psi)
- Brake release pressure : 1.5 MPa (218 psi)
- Weight : 42 kg (93 lbs.)

2-2-4. Differential lock valve (TW types)

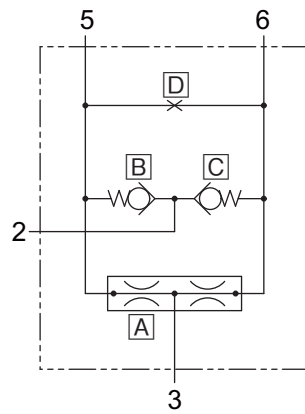
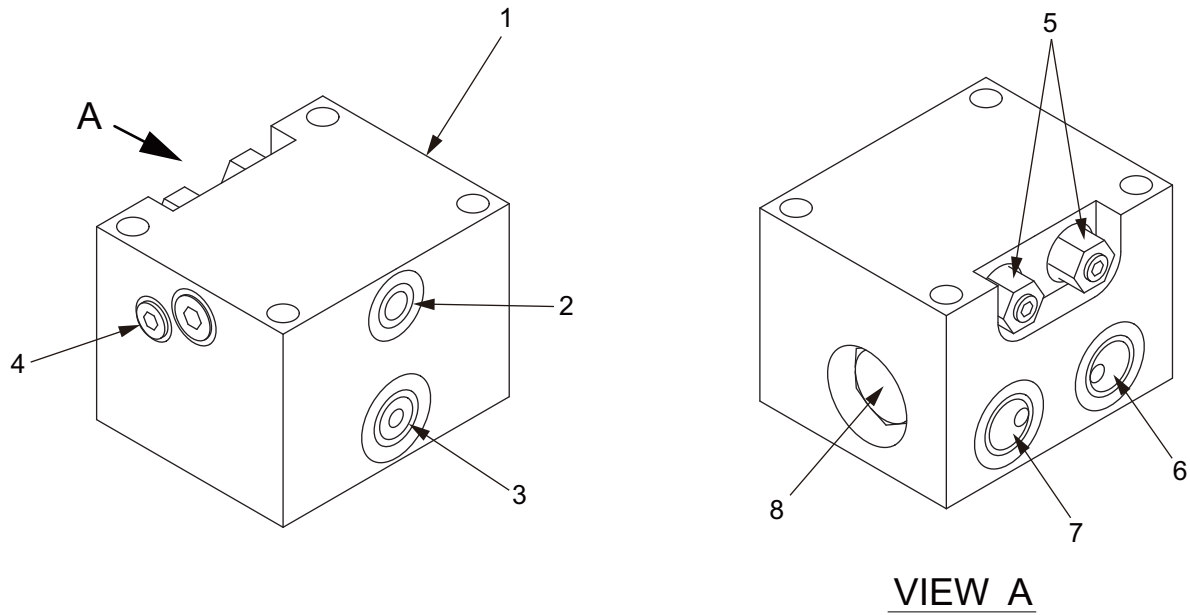

Hydraulic diagram

SW300-1-04004

- (1) Body
- (2) Port C **[DC]** : 9/16-18UNF
- (3) Port A **[DA]** : 3/4-16UNF
- (4) Orifice **[D]**
- (5) Check valve **[B][C]**
- (6) Port B1 **[B1]** : 3/4-16UNF
- (7) Port B2 **[B2]** : 3/4-16UNF
- (8) Flow control valve **[A]**

Specifications

- Maximum control flow (interflow) : 45 L/min (12 gal./min)
- Rated pressure : 20.6 MPa (2,987 psi)
- Check valve cracking pressure : 0.034 MPa (5 psi)
- Flow division ratio (B1 : B2) : 1 : 1
- Weight : 4.6 kg (10 lbs.)

3. VIBRATOR HYDRAULIC SYSTEM

3-1. Vibrator Hydraulic Piping

3-1-1. Vibrator hydraulic piping (1) (SW types: main)

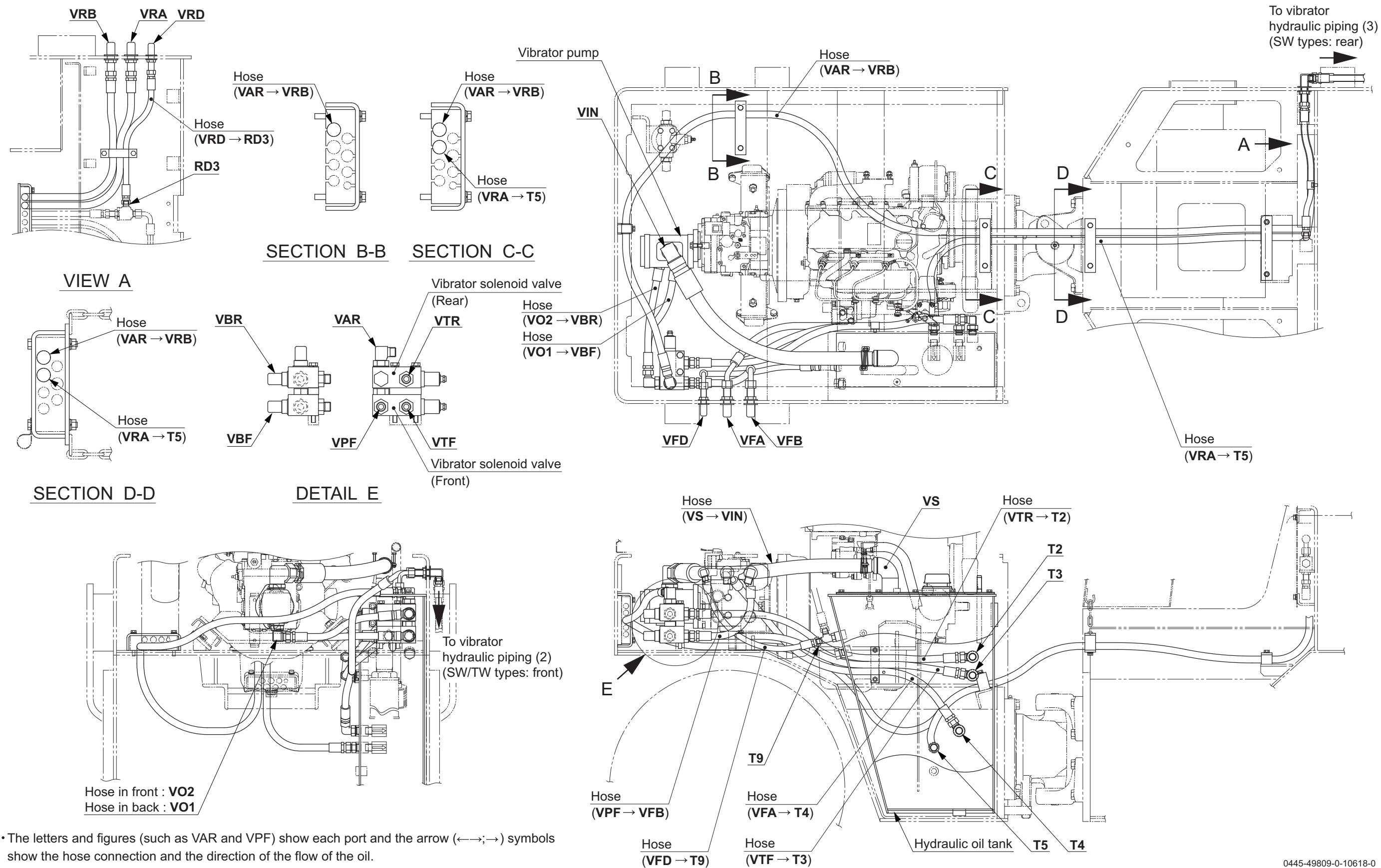

• The letters and figures (such as VAR and VPF) show each port and the arrow (←→;→) symbols show the hose connection and the direction of the flow of the oil.

0445-49809-0-10618-0

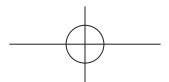
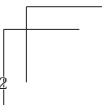
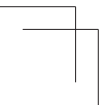
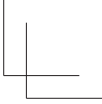
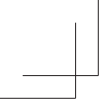

3-1-2. Vibrator hydraulic piping (1) (TW types: main)

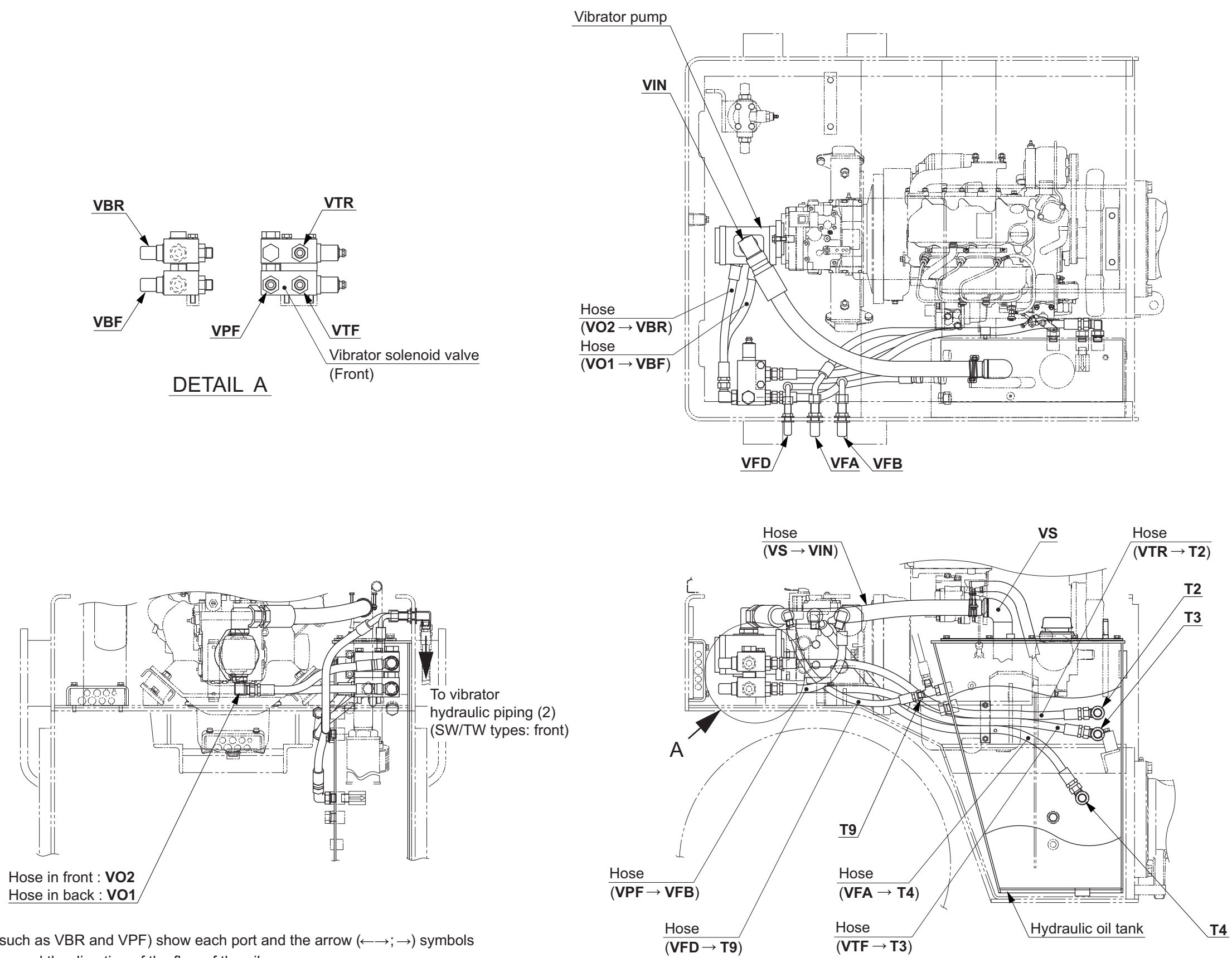

• The letters and figures (such as VBR and VPF) show each port and the arrow (←→; →) symbols show the hose connection and the direction of the flow of the oil.

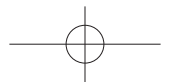
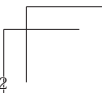
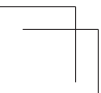
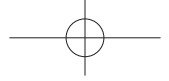

3-1-3. Vibrator hydraulic piping (2) (SW/TW types: front)

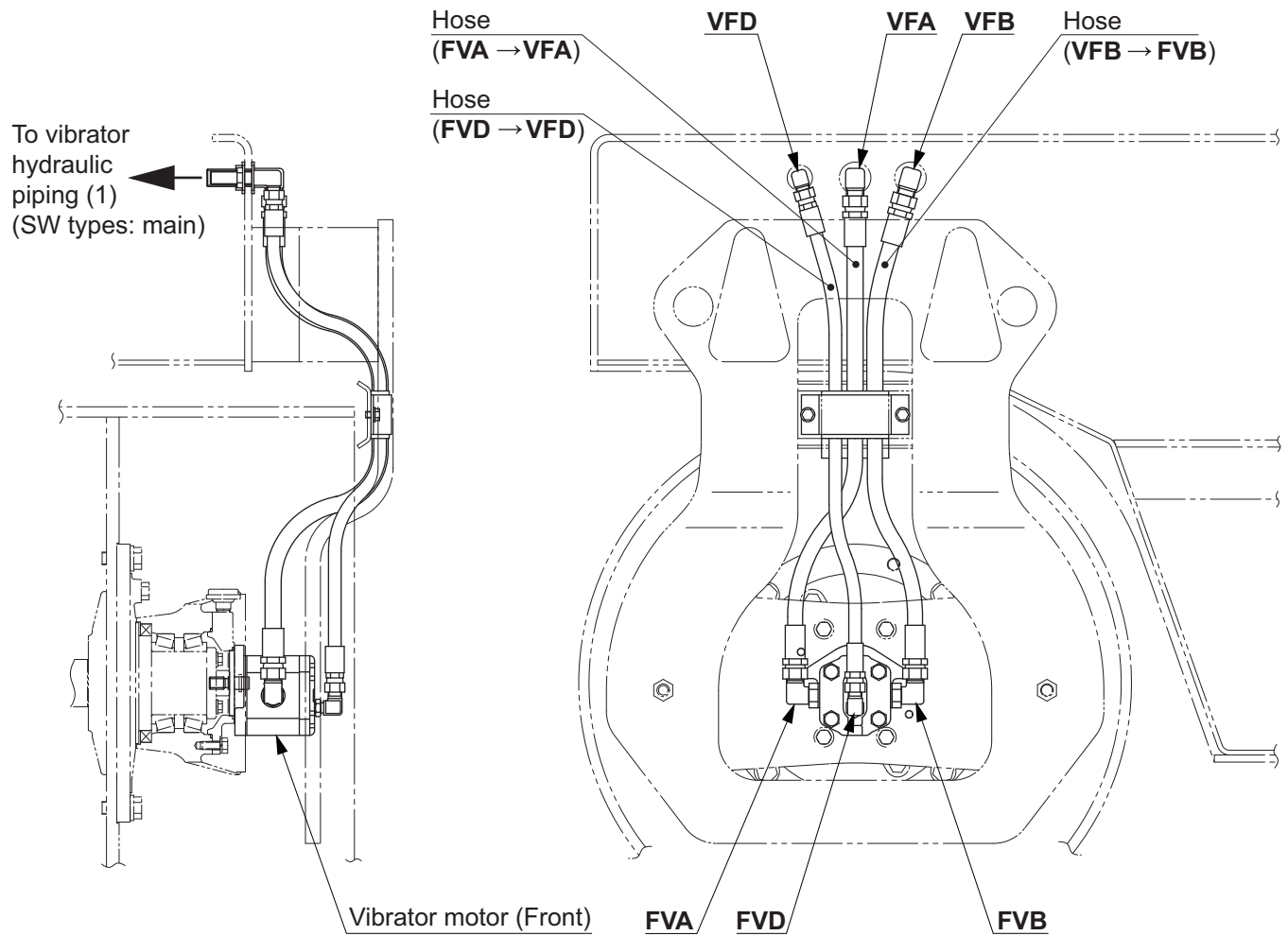

- The letters and figures (such as FVA and FVB) show each port and the arrow (←→; →) symbols show the hose connection and the direction of the flow of the oil.

0445-49811-0-10620-Af

3-1-4. Vibrator hydraulic piping (3) (SW types: rear)

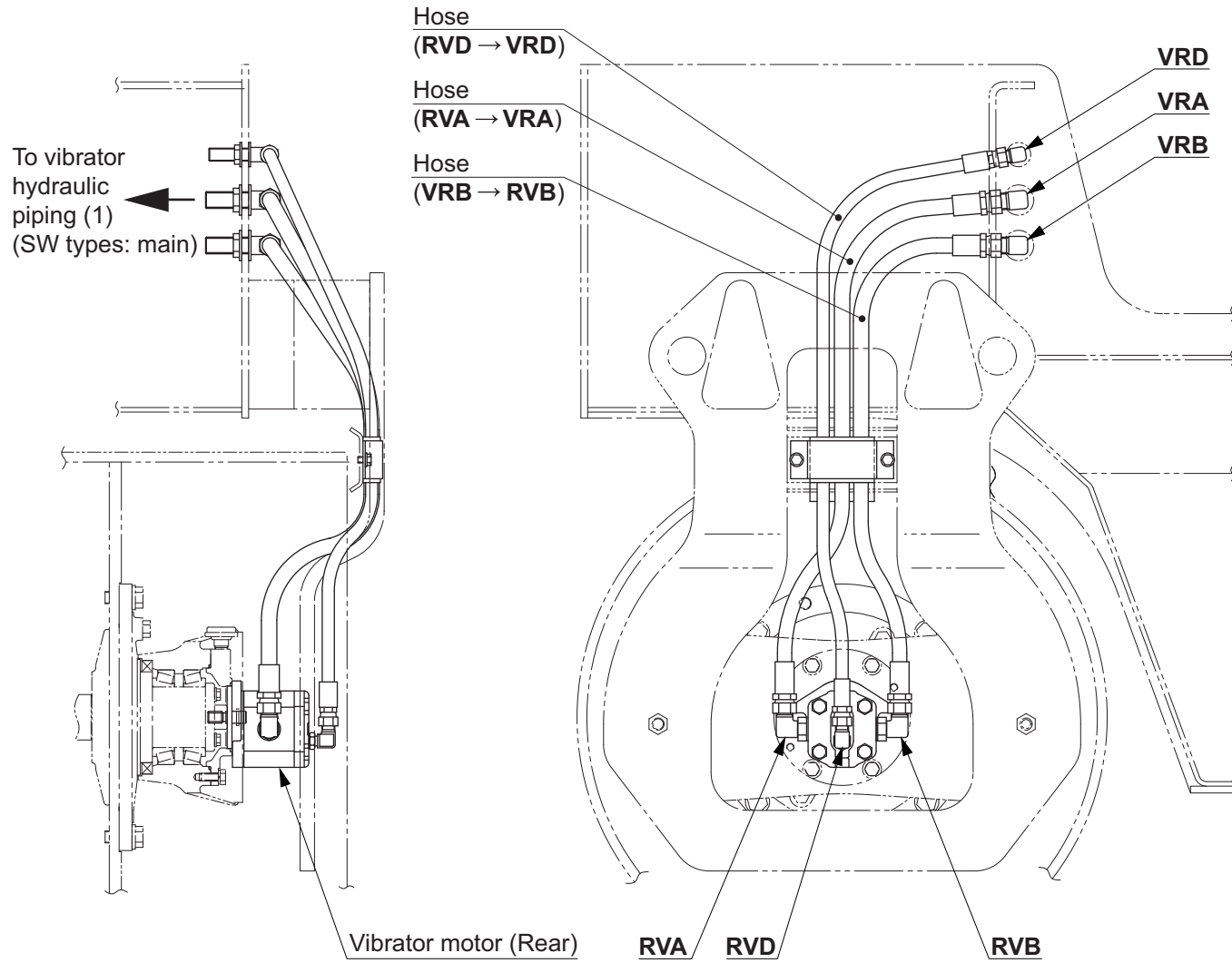

- The letters and figures (such as RVA and RVB) show each port and the arrow (←→;→) symbols show the hose connection and the direction of the flow of the oil.

0445-49811-0-10620-Ar

3-2. Hydraulic Component Specifications

3-2-1. Vibrator pump

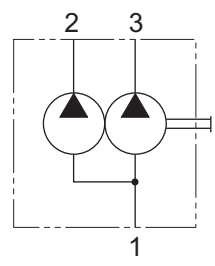
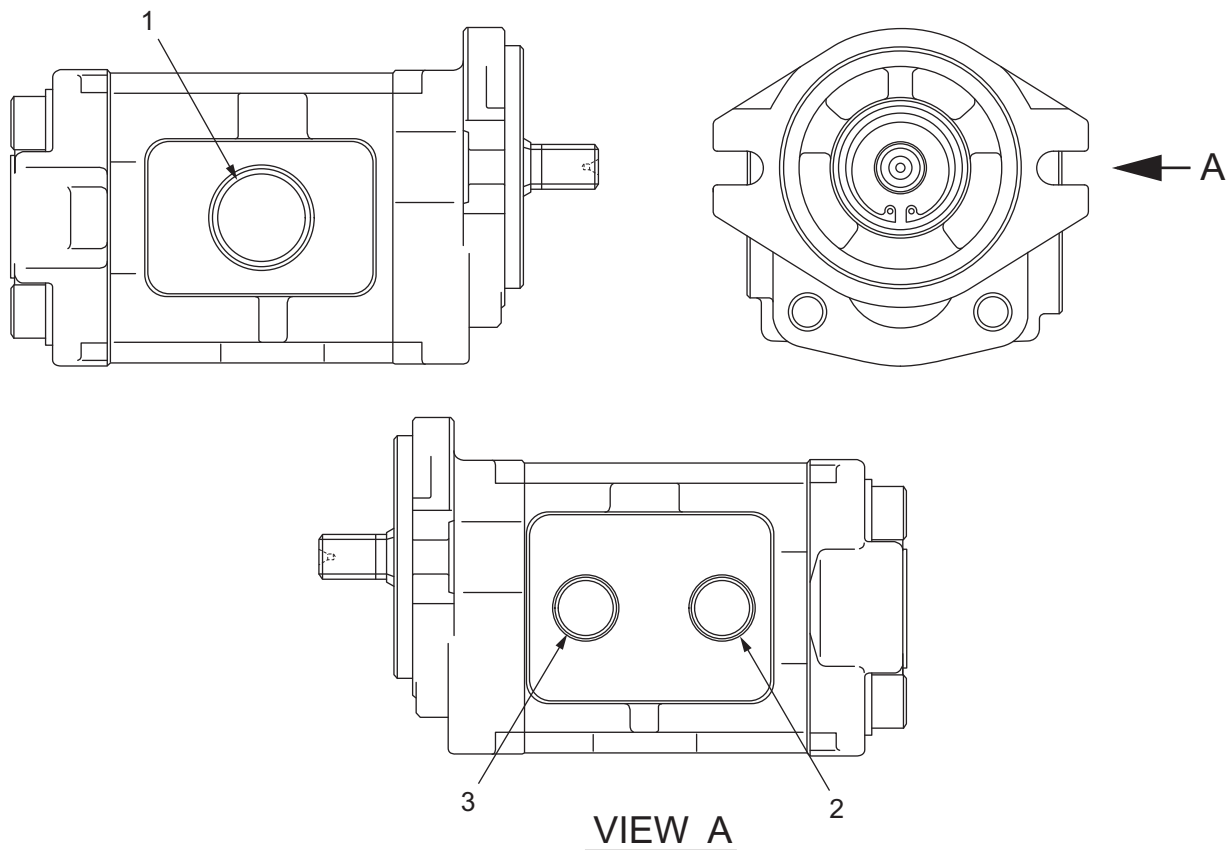

Hydraulic circuit diagram

SW300-1-04007

- | | | |
|----------------------|--------------|--------|
| (1) Inlet port | [VIN] | : G1 |
| (2) No.2 outlet port | [VO2] | : G1/2 |
| (3) No.1 outlet port | [VO1] | : G1/2 |

Specifications

- Displacement (No.1 pump) : 12.5 cm³/rev (0.76 cu.in./rev)
- (No.2 pump) : 12.5 cm³/rev (0.76 cu.in./rev)
- Rated pressure (No.1 pump) : 17.2 MPa (2,494 psi)
- (No.2 pump) : 17.2 MPa (2,494 psi)
- Weight : 7.0 kg (15.4 lbs.)

3-2-2. Vibrator hydraulic motor

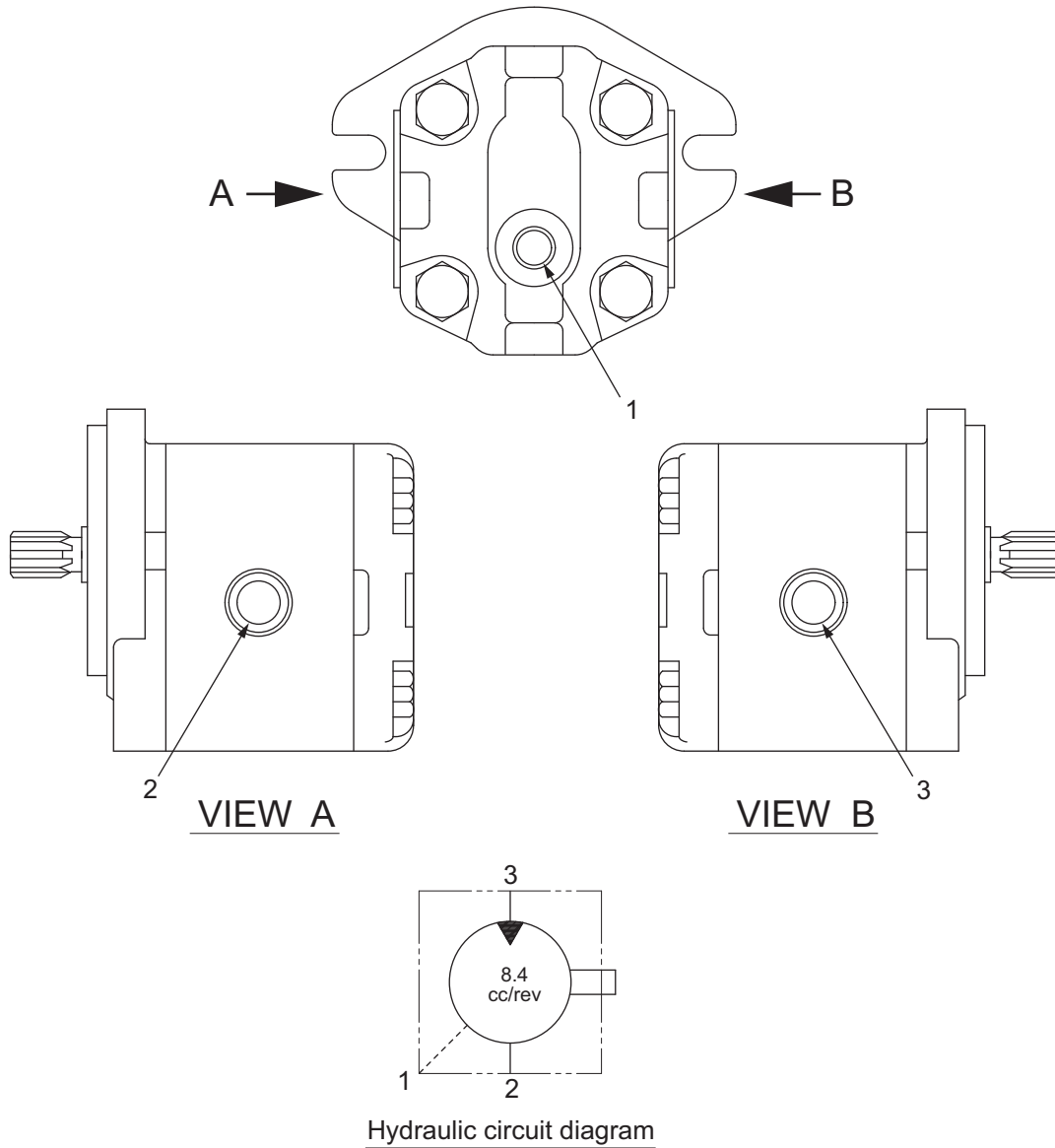

SW300-1-04002

- (1) Drain port **[FVD] [RVD]** : 9/16-18UNF
- (2) Port A **[FVA] [RVA]** : 7/8-14UNF
- (3) Port B **[FVB] [RVB]** : 7/8-14UNF

Specifications

- Displacement : 8.4 cm³/rev (0.51 cu.in./rev)
- Rated pressure : 25.2 MPa (3,654 psi)
- Allowable motor case pressure : 0.7 MPa (101.5 psi) or less
- Weight : 2.7 kg (5.9 lbs.)

3-2-3. Vibrator solenoid valve

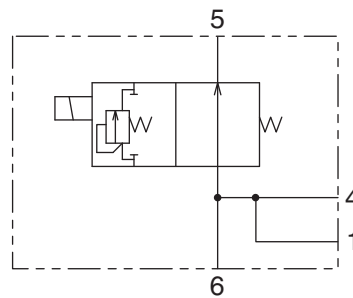
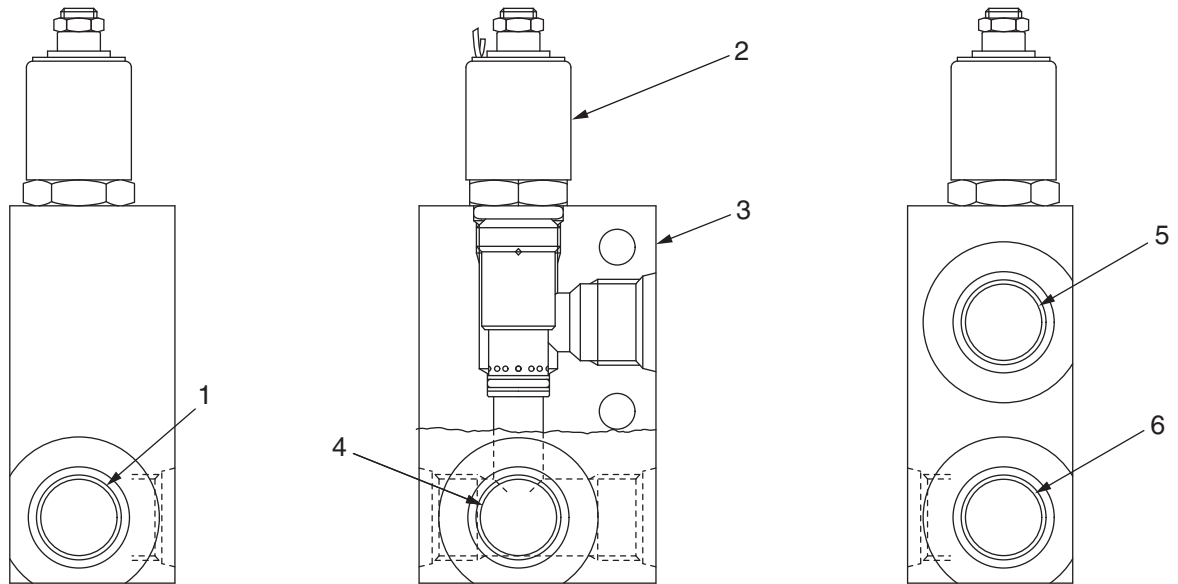

Hydraulic circuit diagram

SW300-1-04003

- | | |
|--------------------|---------------------------|
| (1) Port B | [VBF] [VBR] : G3/4 |
| (2) Solenoid valve | |
| (3) Body | |
| (4) Port A | [VAR] : G3/4 |
| (5) Port T | [VTF] [VTR] : G3/4 |
| (6) Port P | [VPF] : G3/4 |

Specifications

- Maximum flow : 70 L/min (18.5 gal./min)
- Maximum pressure : 20.6 MPa (2,987 psi)
- Relief valve pressure setting : 12.7 MPa (1,842 psi)
- Weight : 2.9 kg (6.4 lbs.)

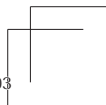
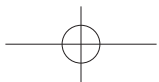
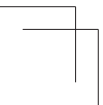
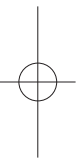
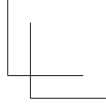
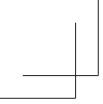

4. STEERING SYSTEM

4-1. Steering Hydraulic Piping

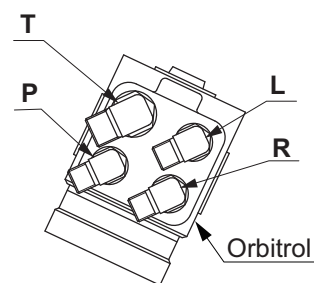

DETAIL A

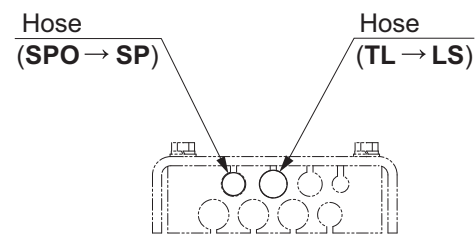

SECTION B-B

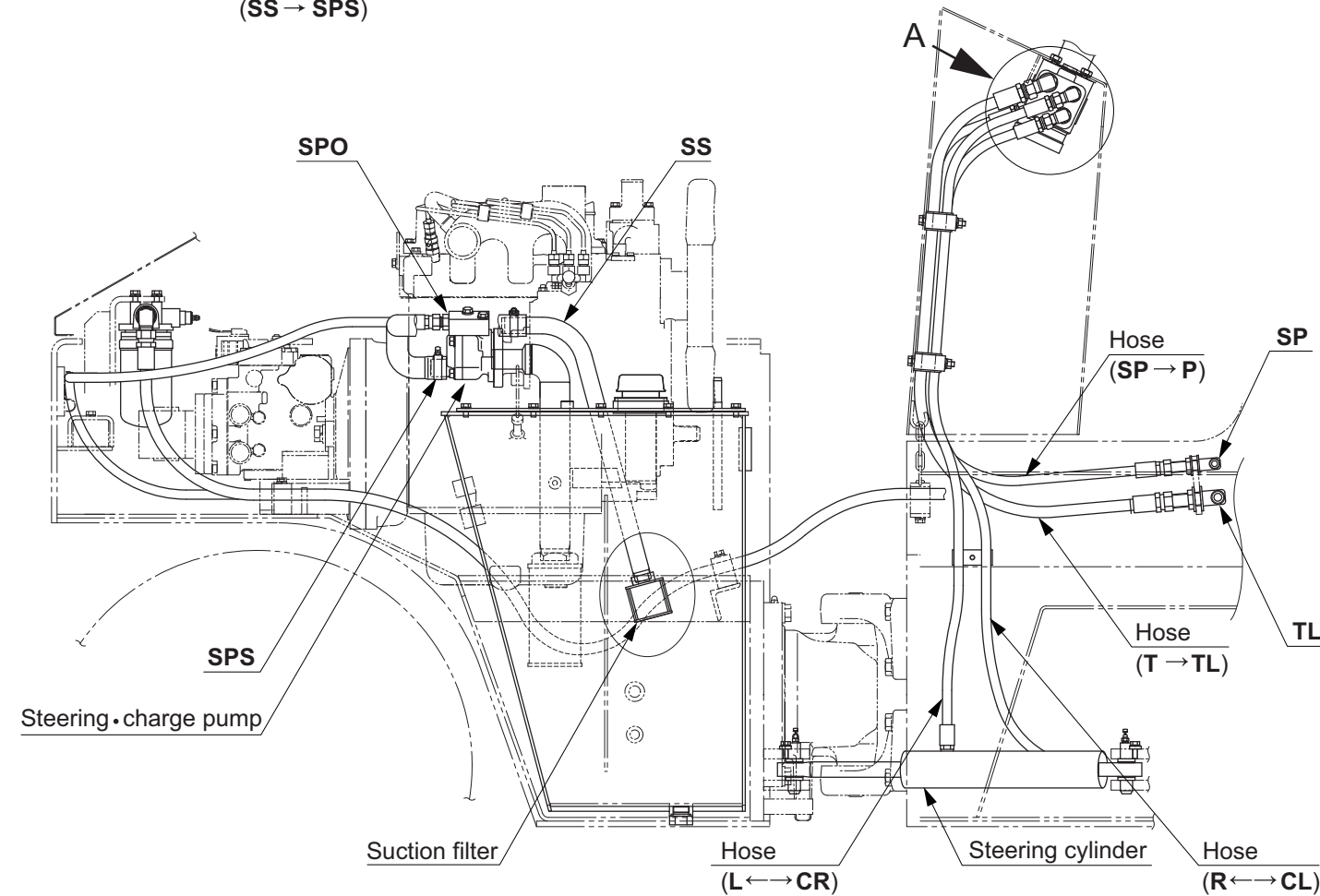
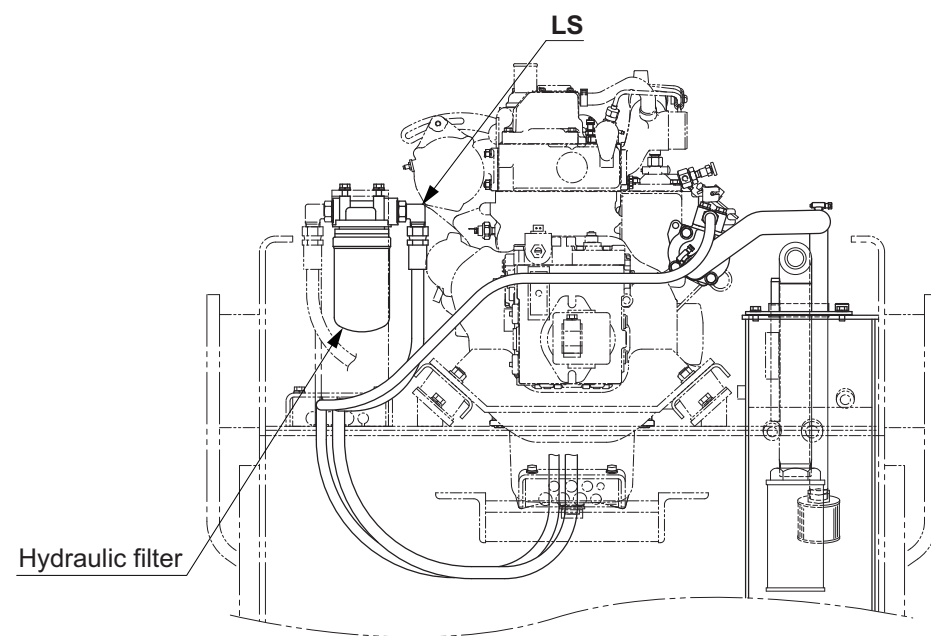
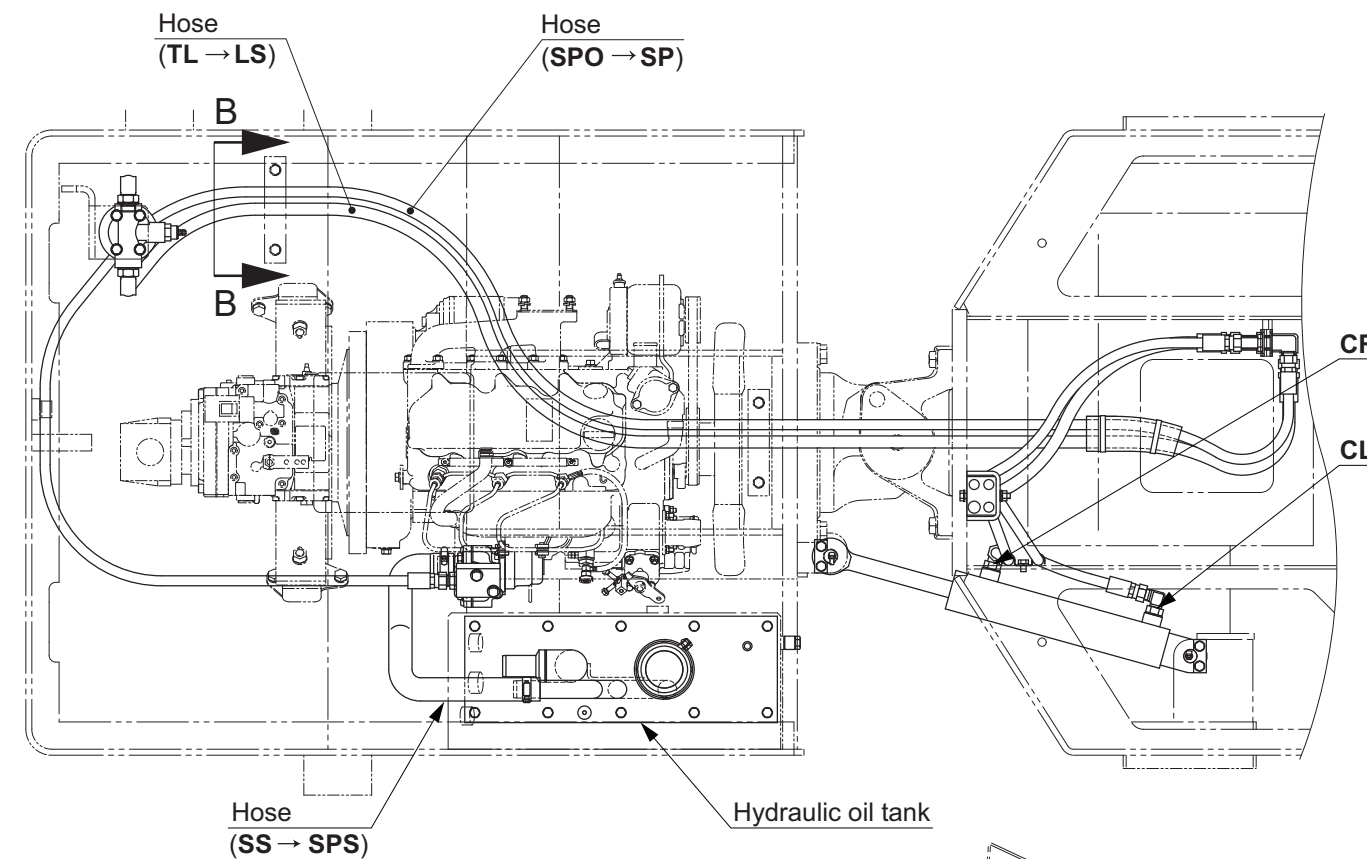

• The letters and figures (such as SPO and SP) show each port and the arrow (←→; →) symbols show the hose connection and the direction of the flow of the oil.

0445-32803-0-10614-B

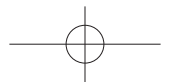
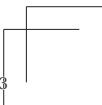
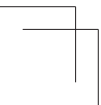
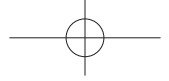
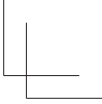
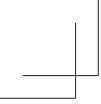

4-2. Steering Wheel

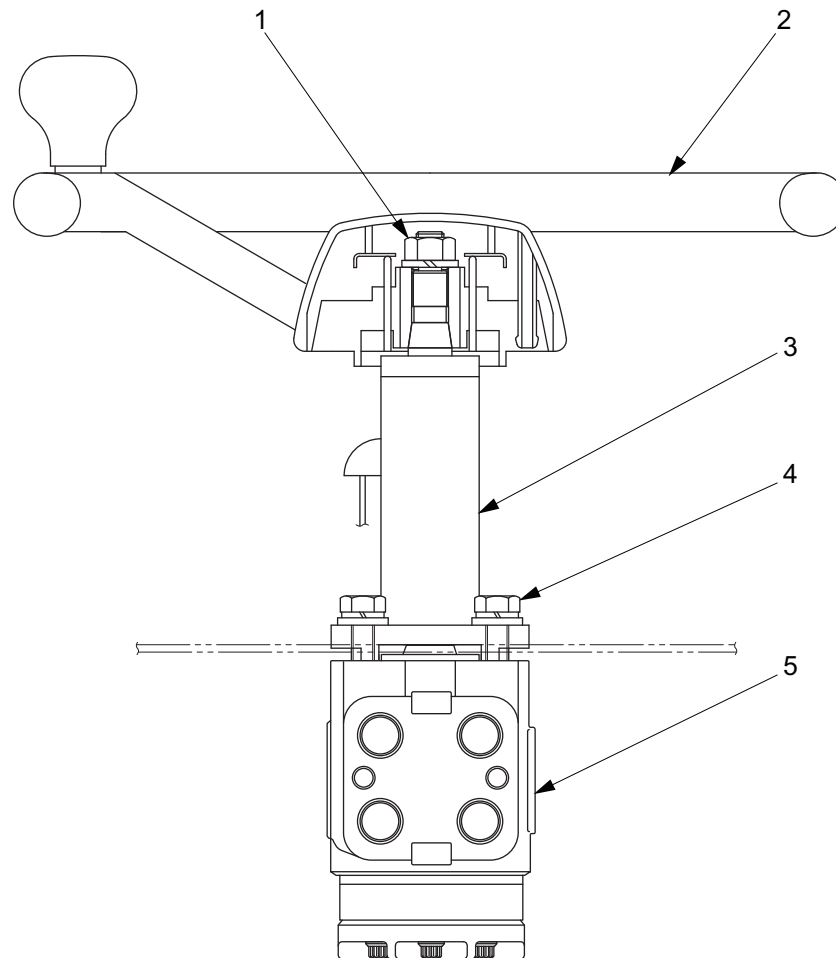

0446-32803-0-20620-0

(1) Nut : M12 P=1.25
 (2) Steering wheel
 (3) Column shaft

(4) Bolt : M10×35
 (5) Orbitrol



(1) Nut M12 P=1.25 : 64 N·m (47 lbf·ft)
 (4) Bolt M10×35 : 39 N·m (29 lbf·ft)

• Steering wheel assembly weight : 11 kg (24 lbs.)

4-3-2. Orbitrol

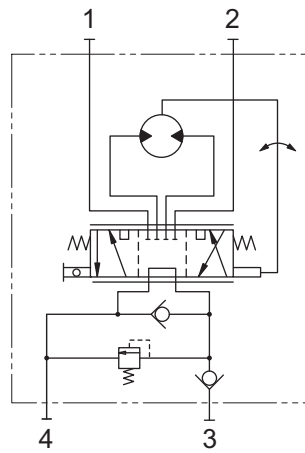
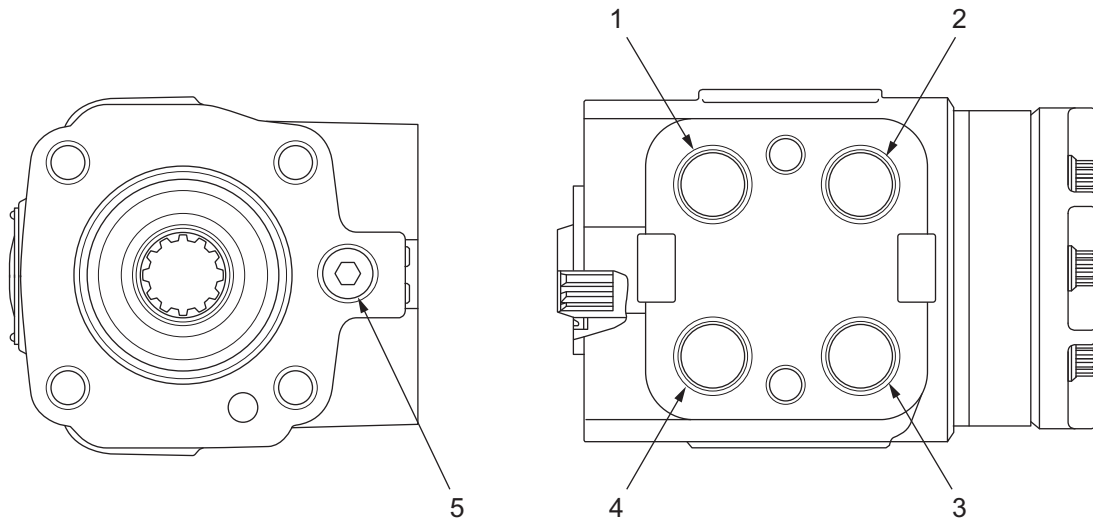

Hydraulic circuit diagram

SW300-1-04009

- (1) Port L **[L]** : 3/4-16UNF
- (2) Port R **[R]** : 3/4-16UNF
- (3) Port P **[P]** : 3/4-16UNF
- (4) Port T **[T]** : 3/4-16UNF
- (5) Relief valve

Specifications

- Displacement : 96 cm³/rev (5.9 cu.in./rev)
- Relief valve pressure setting : 13.2 MPa (1,914 psi)
- Weight : 6.0 kg (13.2 lbs.)

4-4. Frame (Center Pin)

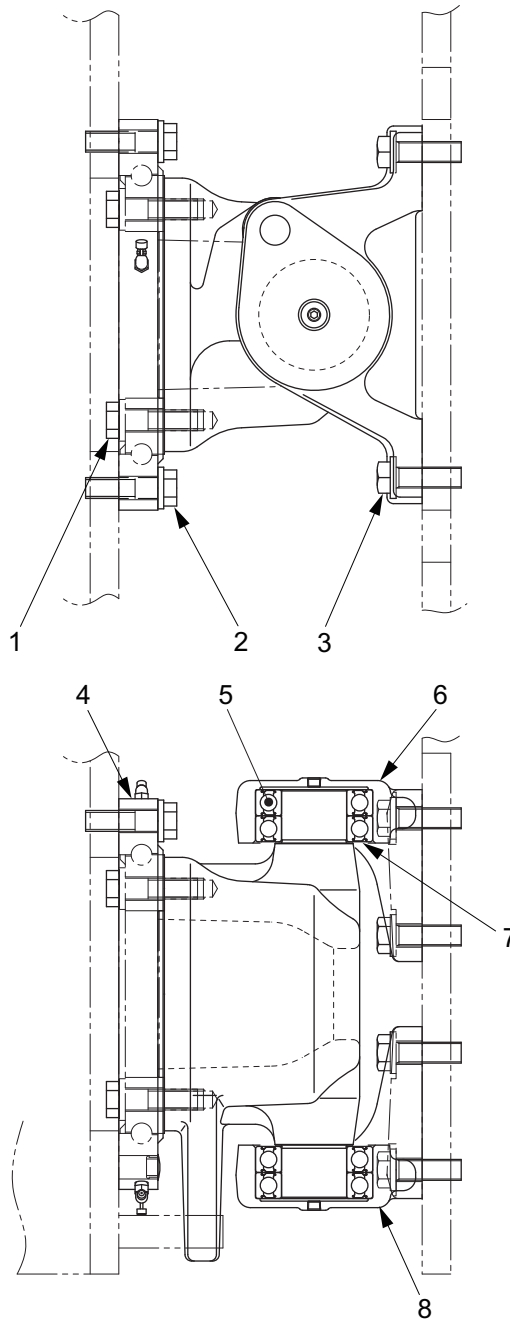

0445-61801-0-10043-B

- | | | | |
|----------|----------|---------------------|---------------------|
| (1) Bolt | : M16×60 | (4) Swing bearing | (7) Cover |
| (2) Bolt | : M16×60 | (5) Ball bearing | (8) Bracket (lower) |
| (3) Bolt | : M16×50 | (6) Bracket (upper) | |



- | | |
|-----------------|--------------------------|
| (1) Bolt M16×60 | : 265 N·m (195 lbf·ft) |
| (2) Bolt M16×60 | : 265 N·m (195 lbf·ft) |
| (3) Bolt M16×50 | : 265 N·m (195 lbf·ft) |



ELECTRICAL SYSTEM



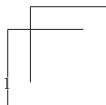
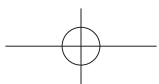
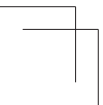
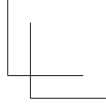
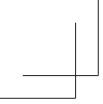

1. SYSTEM CIRCUIT DIAGRAM

1-1. Electrical Circuit Diagram (SW types)

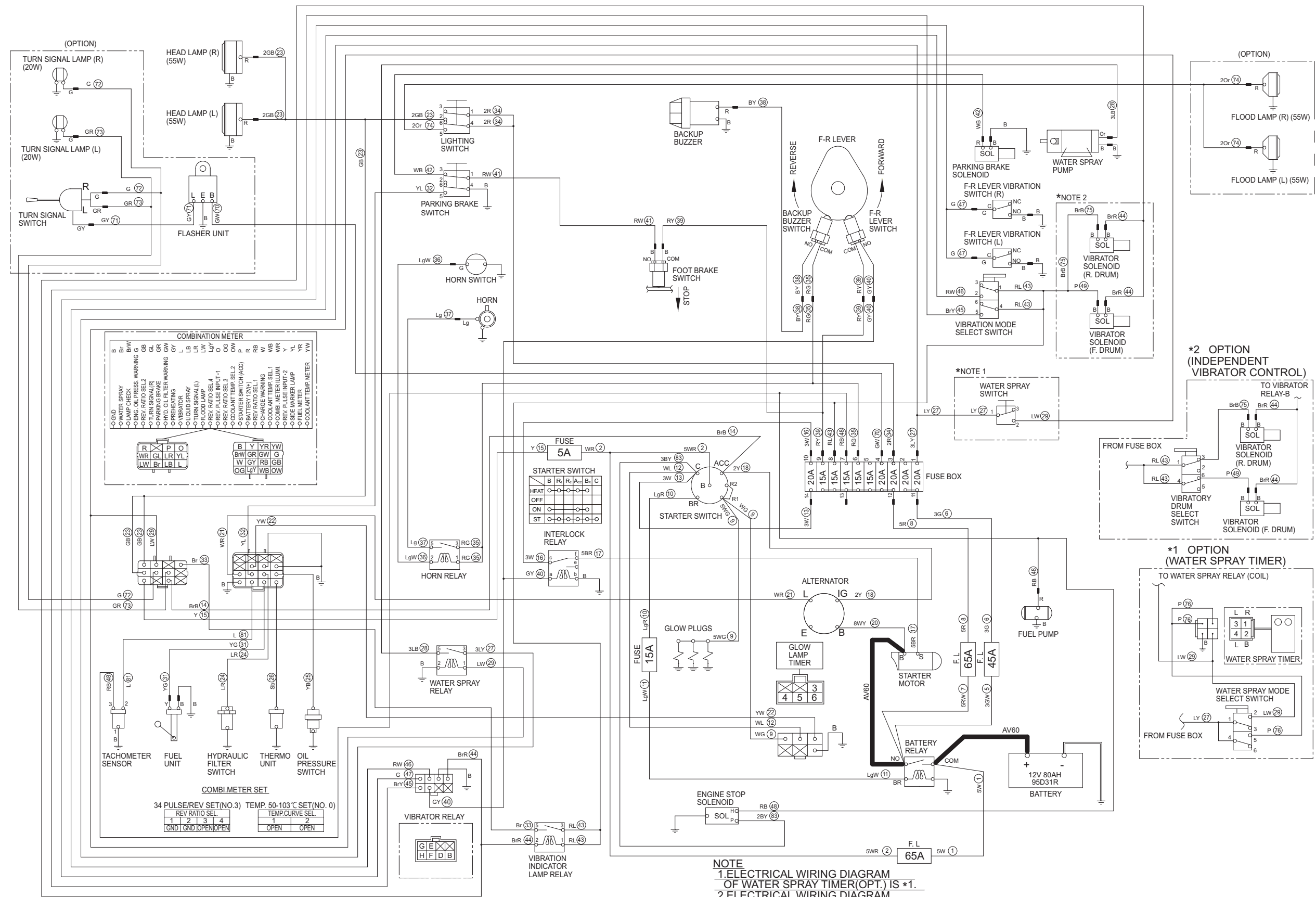

NOTE
 1. ELECTRICAL WIRING DIAGRAM OF WATER SPRAY TIMER (OPT.) IS #1.
 2. ELECTRICAL WIRING DIAGRAM OF INDEPENDENT VIBRATOR CONTROL (OPT.) IS #2.

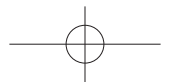
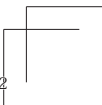
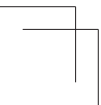
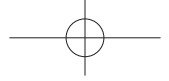
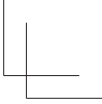
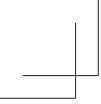

1-2. Electrical Circuit Diagram (TW types)

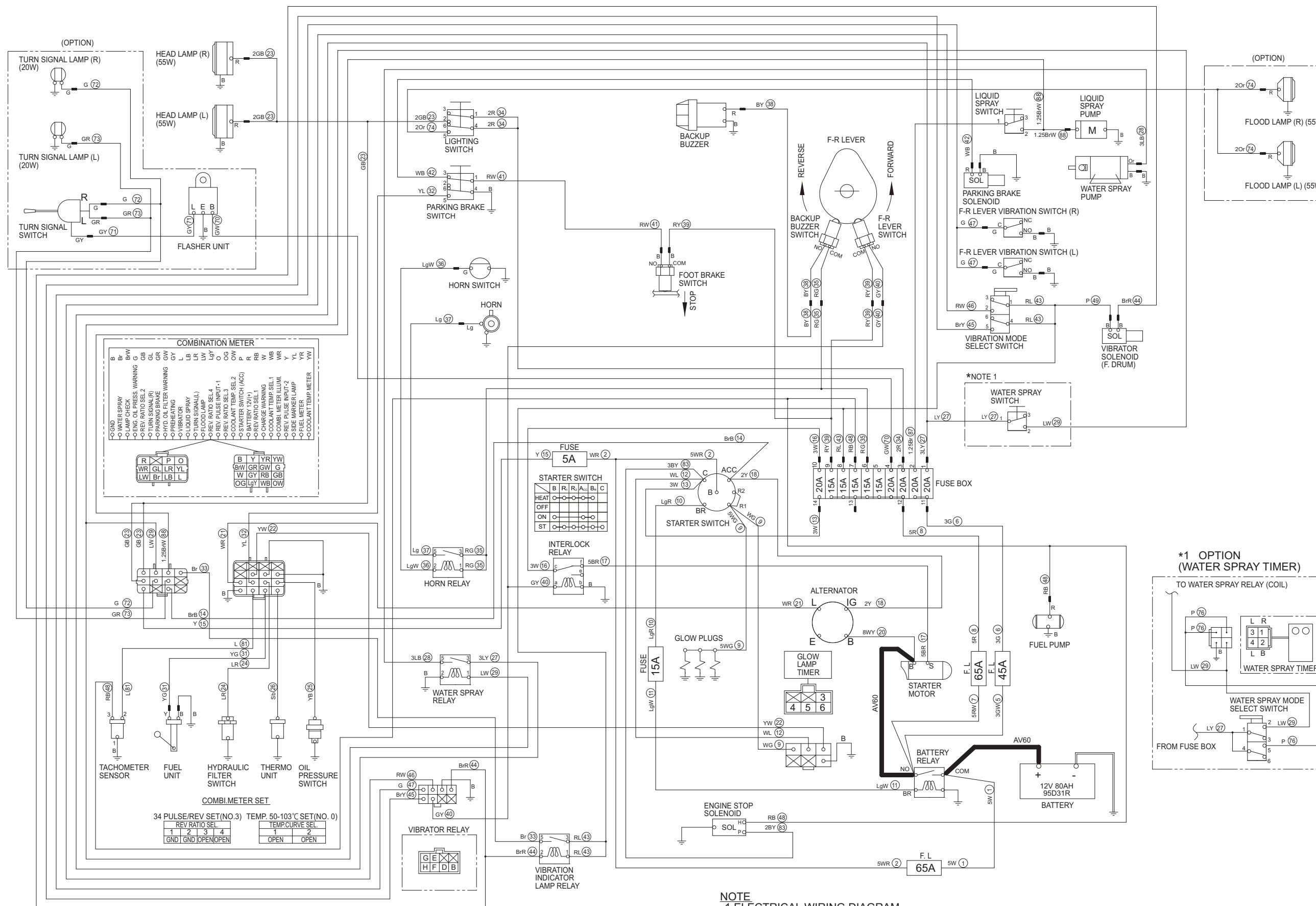

0425-99007-0-10078-A

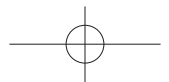
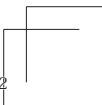
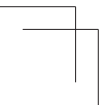
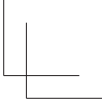
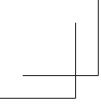

2. ELECTRICAL COMPONENTS

2-1. Electrical Component Layout

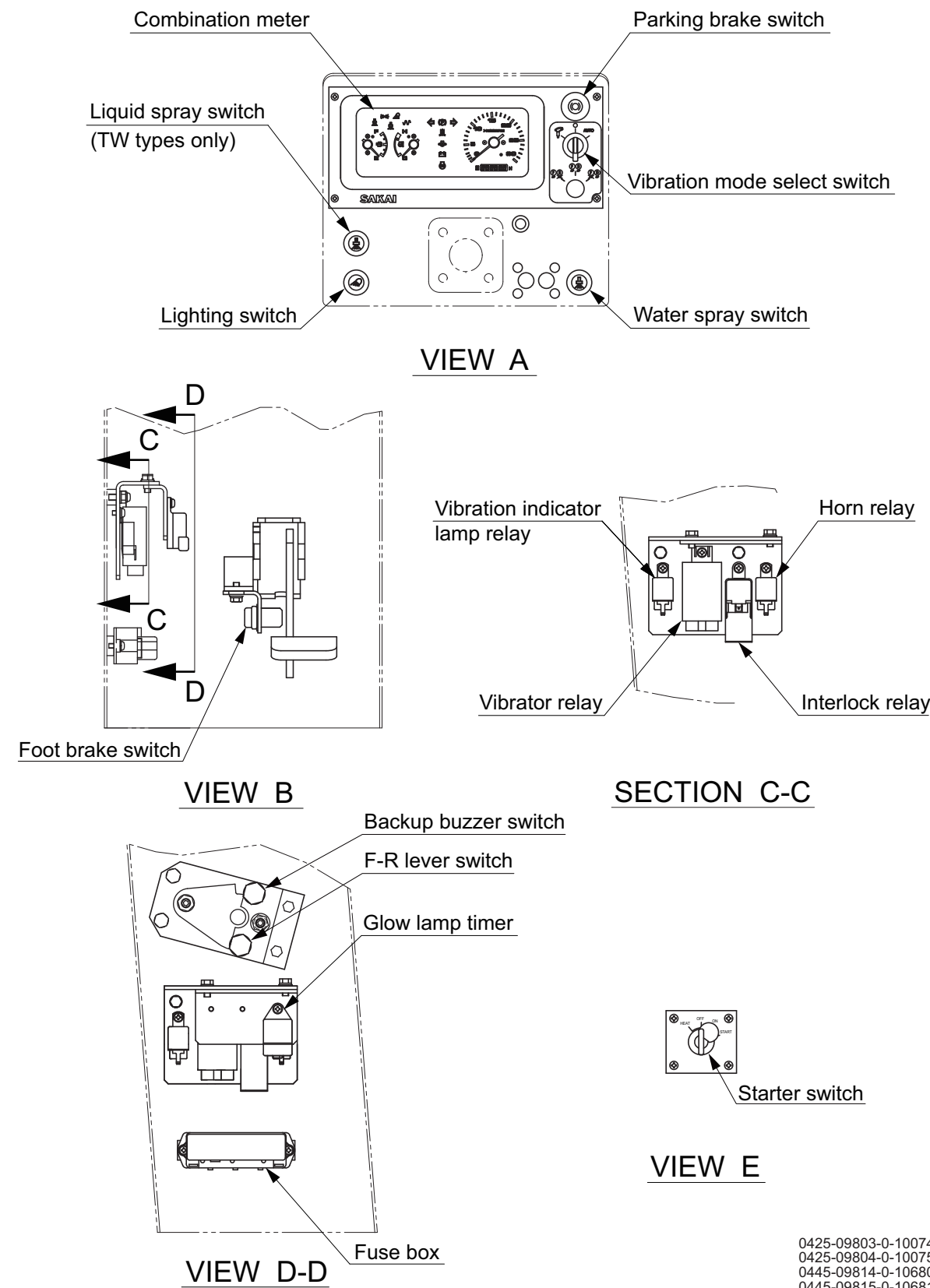
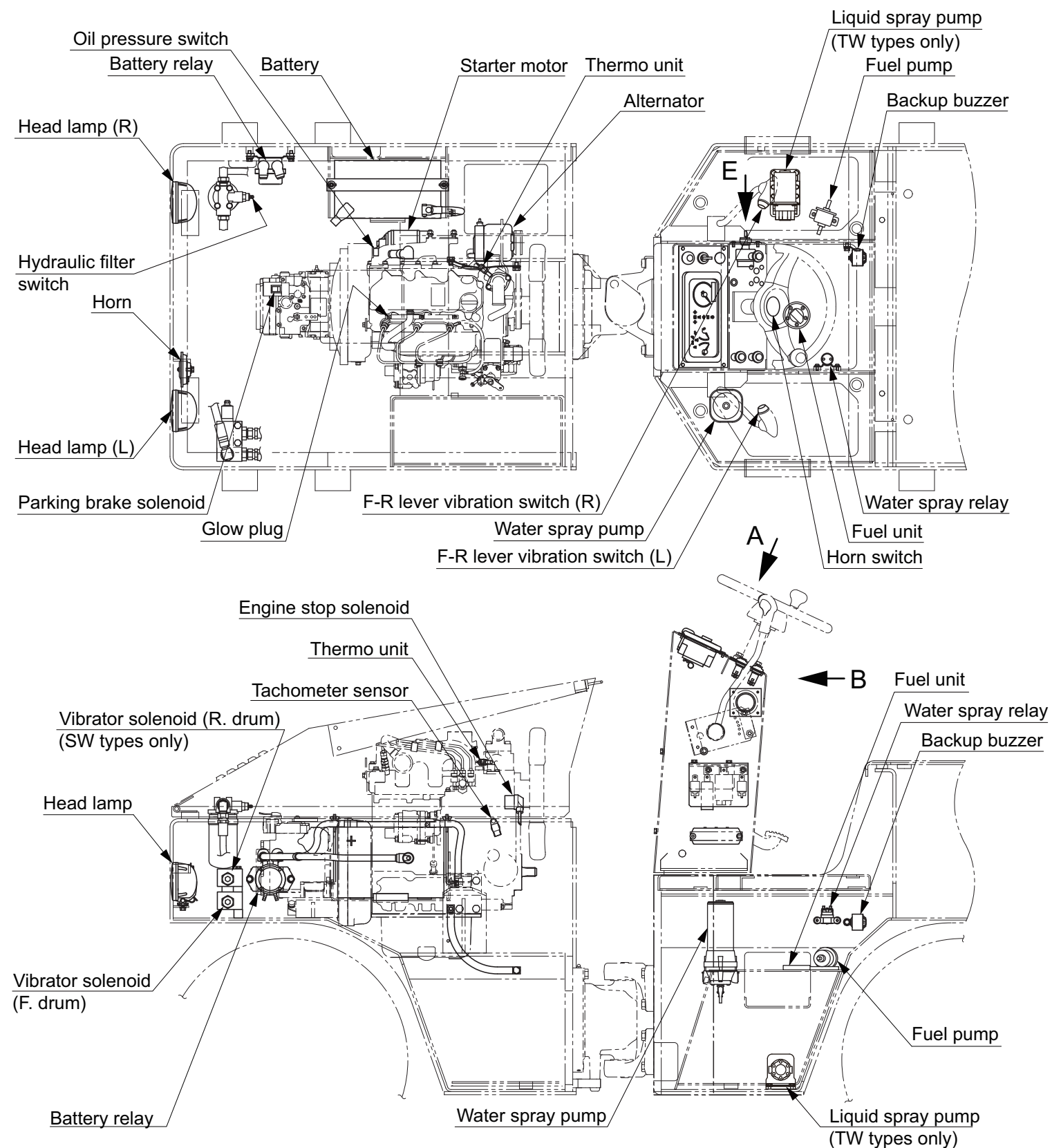

0425-09803-0-10074-A
 0425-09804-0-10075-C
 0445-09814-0-10680-A
 0445-09815-0-10681-C

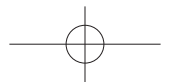
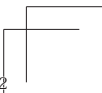
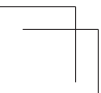

3. ELECTRICAL COMPONENT SPECIFICATIONS

3-1. Fuse Box

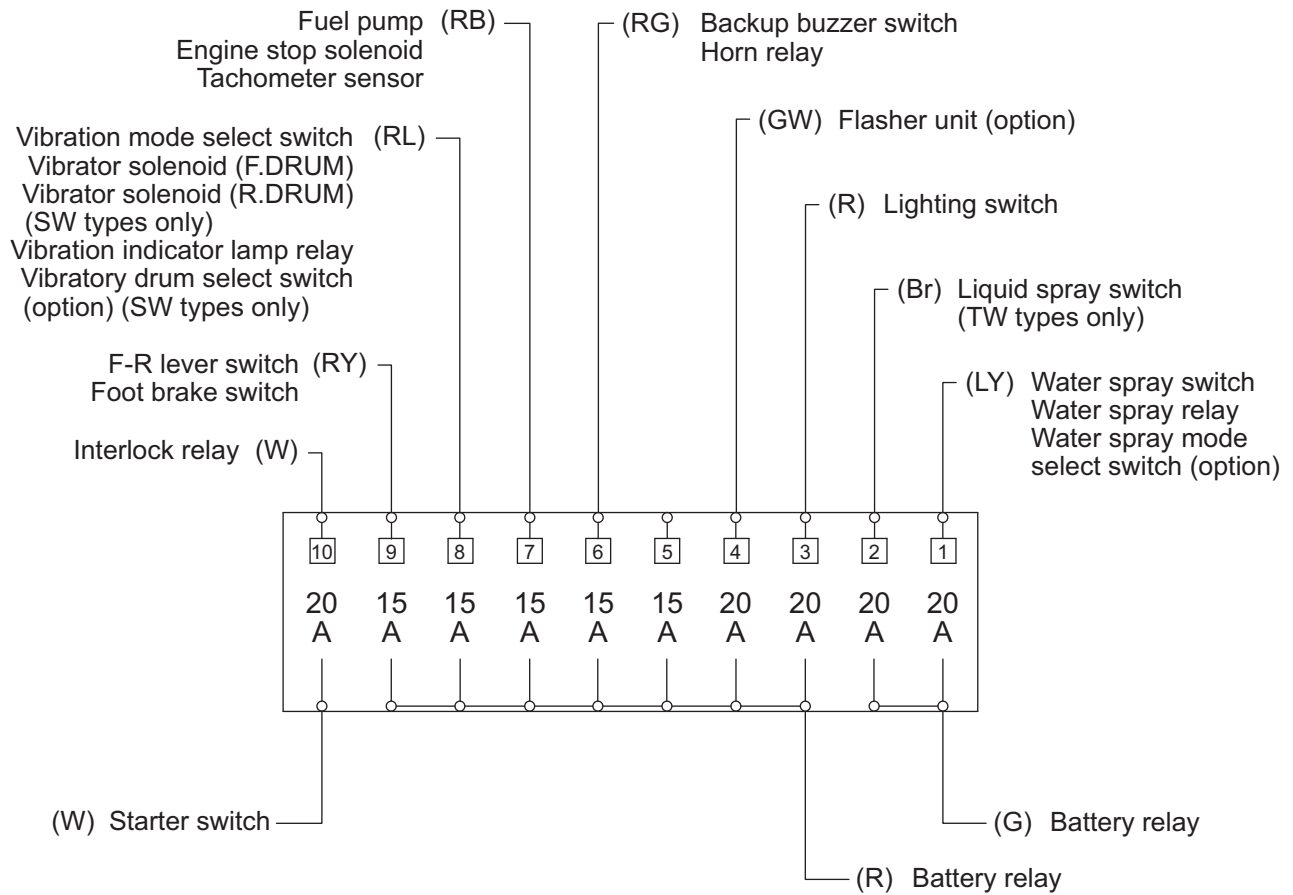

SW300-1-05002

Harness color codes

- | | |
|------------------------|--------------------------|
| W : White | R Y : Red/Yellow stripe |
| R : Red | R G : Red/Green stripe |
| G : Green | R L : Red/Blue stripe |
| Br : Brown | G W : Green/White stripe |
| R B : Red/Black stripe | L Y : Blue/Yellow stripe |

3-2. Combination Meter

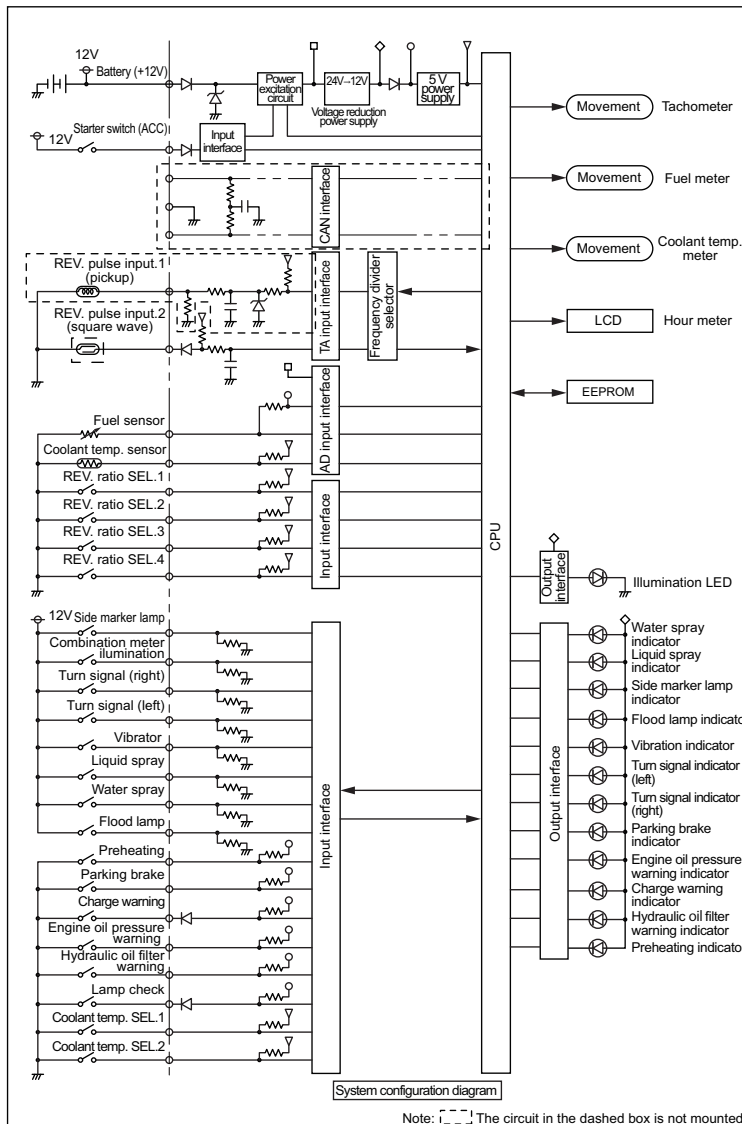
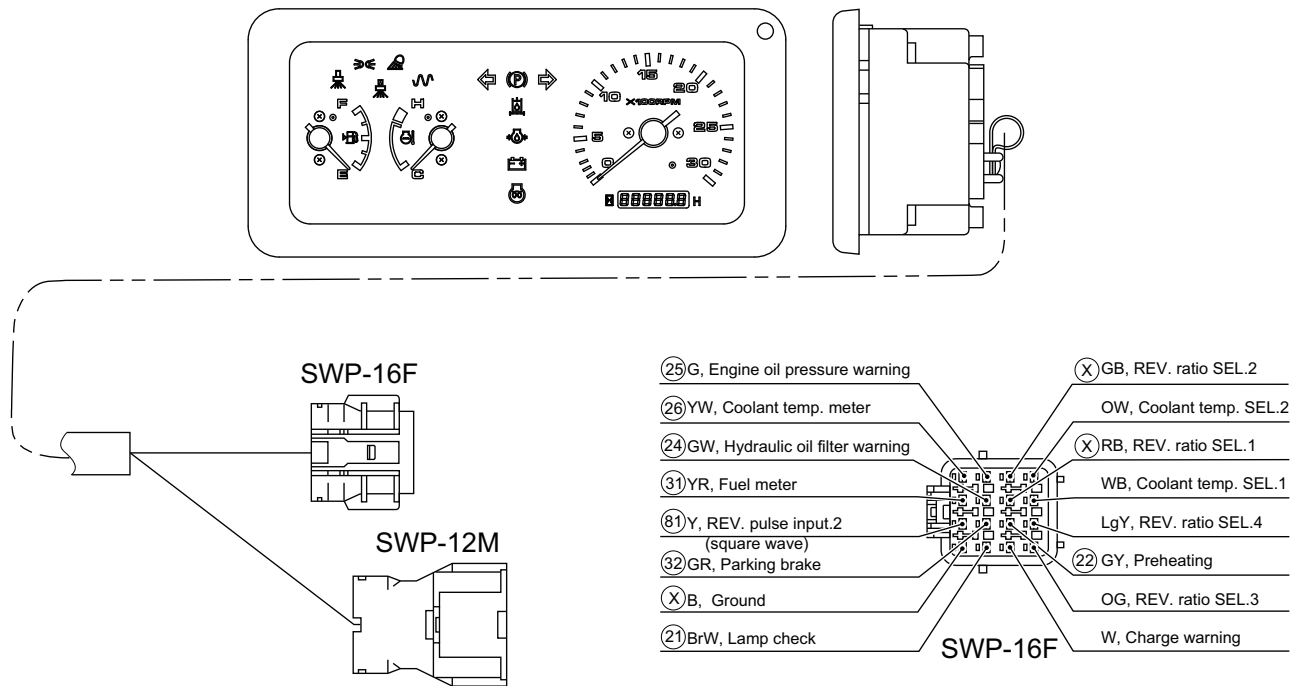

Harness side

X	21	*	*
B	WR	*	*
81	32	22	*
L	YL	YW	*
31	24	X	*
YG	LR	B	*
26	25	X	*
Sb	YB	B	*

SWP-16M

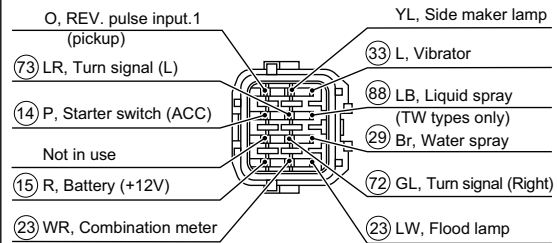

SWP-12M

Harness side

15	23	23
Y	GB	GB
*	72	29
*	G	LW
14	73	88
BrB	GR	BrW
*	*	33
*	*	Br

← TW types only

SWP-12F

Wire color and number (Refer to "1-4 Wire Color Code and Number" of TROUBLESHOOTING.)

- The arrangement of connector terminals shown below is that of connecting surfaces on the connector side.



VIBRATORY DRUM - REAR WHEEL

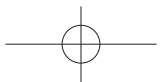
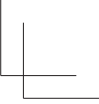
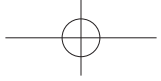

1. PRECAUTIONS FOR DISASSEMBLY AND REASSEMBLY

- When removing, installing, disassembling or reassembling the unit, observe the general precautions described below.

1) Precautions for removal work

- Coolant that contains antifreeze should be treated as a chemical, and must not be drained carelessly on the ground.
- To prevent dust from getting into disconnected hoses and tubes, cover them with a plug or similar means.
- When draining oil, use a receptacle with sufficient capacity to receive it.
- Before proceeding with the work, look for matchmarks that show the installation location. For reassembly, place matchmarks in the required locations to prevent errors. Then remove.
- When disconnecting wiring connectors, hold the connector components so that unreasonable force is not applied to the wires.
- Label wires and hoses to ensure correct installation location.
- Confirm the number and thickness of shims prior to storage.
- When lifting parts, use lifting equipment of sufficient capacity.
- When separating parts by using pull bolts, tighten the bolts alternately.
- Before removing a unit, clean its surrounding area. Then after removal, cover it to prevent dust and other substances from getting in.
- Before removing piping for hydraulic oil or coolant, or removing related parts, satisfactorily release internal pressure.

2) Precautions for installation work

- Tighten bolts and nuts (sleeve nuts) to the specified torque (screw tightening torque table).
- When installing hoses, do not twist them or allow them to interfere with other parts.
- Replace gaskets, O-rings, split cotter pins, and lock plates with new parts.
- Properly bend split cotter pins and lock plates.
- When applying an adhesive, first clean and remove oil/grease from the surfaces properly. Then apply two or three drops to the threaded areas.
- When applying a liquid gasket, first clean and remove oil/grease from the application surface properly, and confirm that the surface is free of dust and damage. Then apply the product evenly.
- Clean parts well. Repair scratches, dents, burrs, rust, etc.
- Apply gear oil to rotating and sliding components.
- Apply grease to the surfaces of press-fit parts.
- After installing snap rings, confirm that they are properly seated in the grooves.
- Connect wiring connectors securely after cleaning off adhering oil, dust and water.
- Use lifting bolts that are not fatigued or deformed. Screw them in fully.
- When tightening a split flange, tighten screws alternately to prevent uneven tightening.
- Before installing hydraulic parts, confirm that they are free of damage and dust, etc.

VIBRATORY DRUM - REAR WHEEL

3) Precautions when work is completed

- If coolant has been drained, securely retighten the drain cock and fill with coolant (mixing in long-life coolant) to the specified level. Start the engine and allow the coolant to circulate through the piping. Then add coolant again to the specified level.
- If hydraulic equipment has been removed and reinstalled, fill with hydraulic oil to the specified level. Start the engine and allow the oil to circulate through the piping. Then add oil again to the specified level.

2. VIBRATORY DRUM

2-1. Removal and Installation of Vibratory Drum

- Hold vibratory drum with chocks.

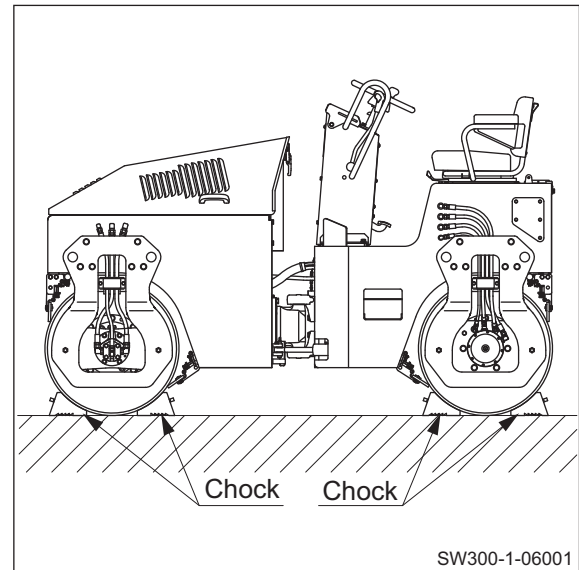

- Lock front and rear frames with lock pin (1).

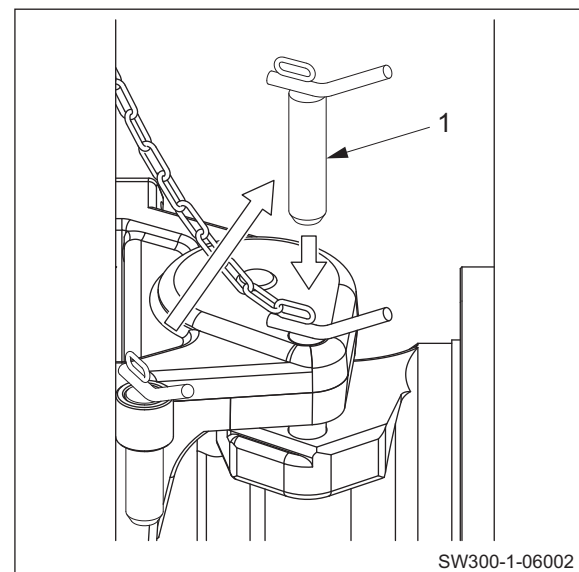

2-1-1. Removal of front vibratory drum

WARNING

The hydraulic oil in the machine is hot and compressed immediately after the machine is stopped. Disconnecting the hydraulic hoses in this condition can cause burns. Wait for the hydraulic oil to cool down before starting the work.

1) Disconnecting piping

1-1) Propulsion motor piping

- Remove bolts (3).
- Remove clamp (2).
- Disconnect hydraulic hoses (4), (5), (6) and (7) connecting to propulsion motor.

(NOTICE)

- Plug both ends of the disconnected hoses or implement other actions to prevent entry of foreign matter.

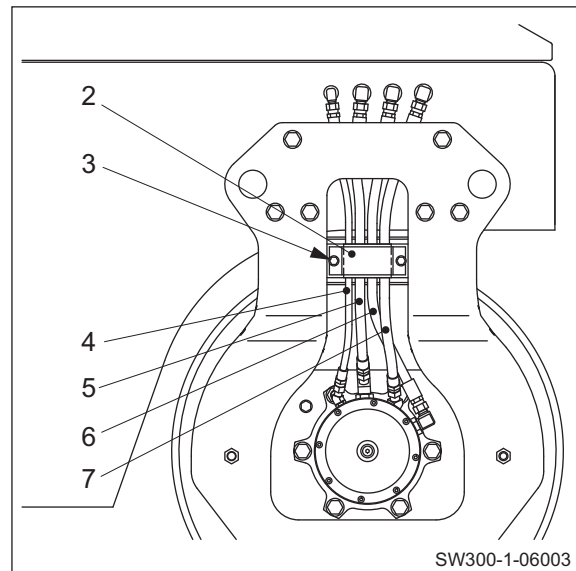

1-2) Vibrator motor piping

- Remove bolts (9).
- Remove clamp (8).
- Disconnect hydraulic hoses (10), (11) and (12) connecting to vibrator motor.

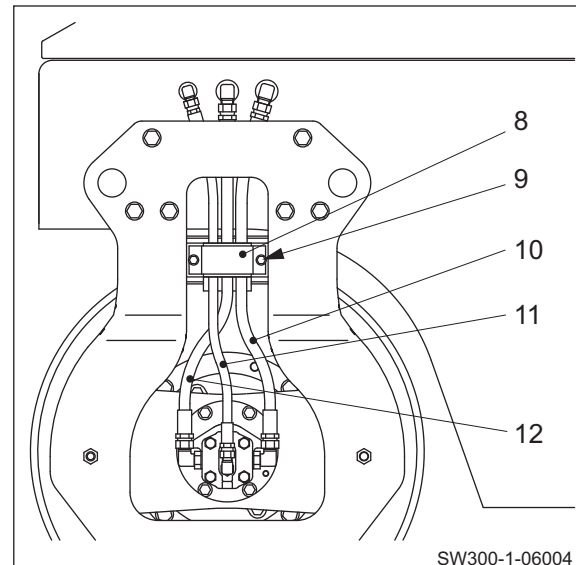

⚠ DANGER

When lifting the machine body, use an appropriate hoist of sufficient strength. Confirm that the surrounding area is safe, and work in a natural, unstrained posture. Also, to firmly secure the machine body, use a support stand of sufficient strength.

- 2) Supporting front frame
 - Lift plate with a crane.
 - Place support stands under frame when vibratory drum is slightly off ground to support machine body.

⚠ kg Front axle weight

SW300-1	: 1,315 kg (2,900 lbs.)
SW320-1	: 1,400 kg (3,085 lbs.)
SW330-1	: 1,440 kg (3,175 lbs.)
TW320-1	: 1,410 kg (3,110 lbs.)
TW330-1	: 1,450 kg (3,195 lbs.)

- Flip up scraper blades (13) and (15).
- Remove bolts (14) (left and right sides).

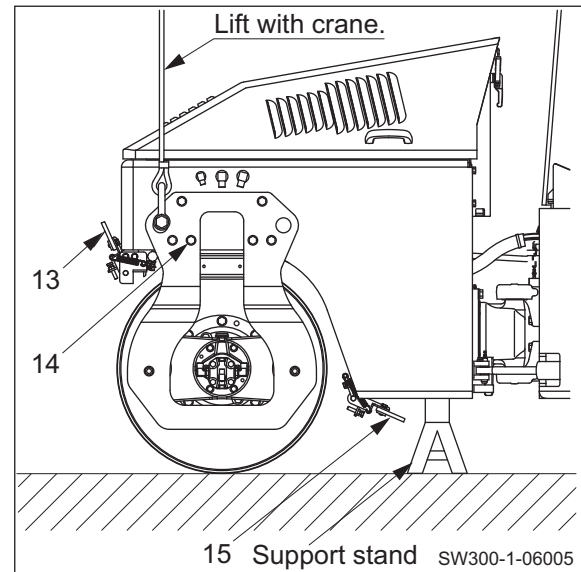

- 3) Removal of vibratory drum
 - Lift left plate (18), right plate (19) and hold them.
 - Lift frame (17) with a crane.
 - Remove vibratory drum together with plates (18), (19) from frame (17).

⚠ kg Vibratory drum ASSY

SW300-1	: 600 kg (1,323 lbs.)
SW/TW320-1	: 670 kg (1,477 lbs.)
SW/TW330-1	: 700 kg (1,543 lbs.)

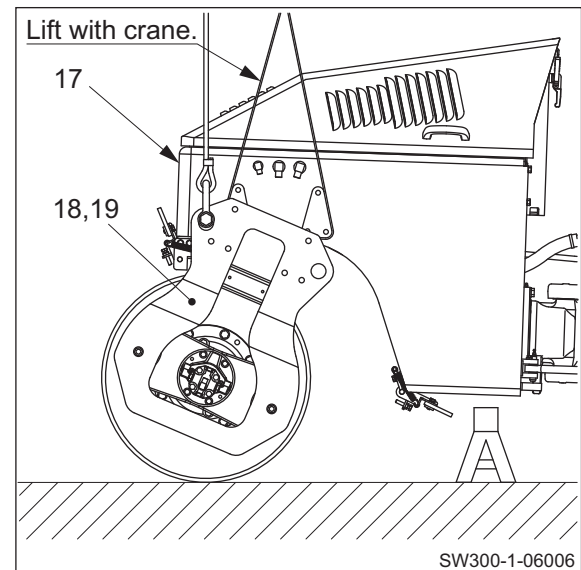

2-1-2. Removal of rear vibratory drum

WARNING

The hydraulic oil in the machine is hot and compressed immediately after the machine is stopped. Disconnecting the hydraulic hoses in this condition can cause burns. Wait for the hydraulic oil to cool down before starting the work.

1) Disconnecting piping

1-1) Propulsion motor piping

- Remove bolts (21).
- Remove clamp (20).
- Disconnect hydraulic hoses (22), (23), (24) and (25) connecting to propulsion motor.

(NOTICE)

- Plug both ends of the disconnected hoses or implement other actions to prevent entry of foreign matter.

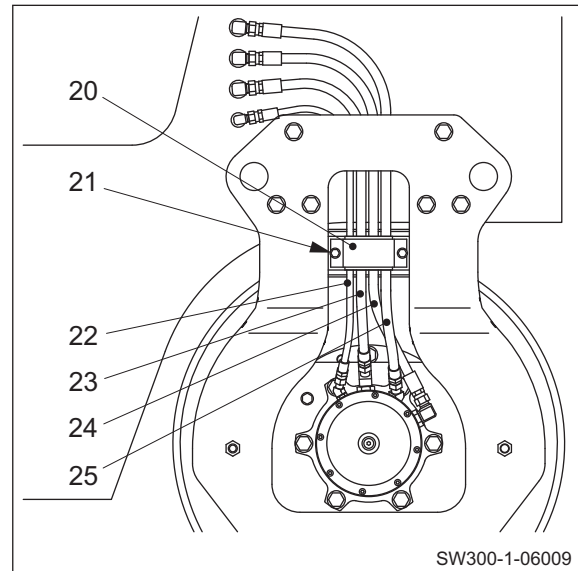

1-2) Vibrator motor piping

- Remove bolts (27).
- Remove clamp (26).
- Disconnect hydraulic hoses (28), (29) and (30) connecting to vibrator motor.

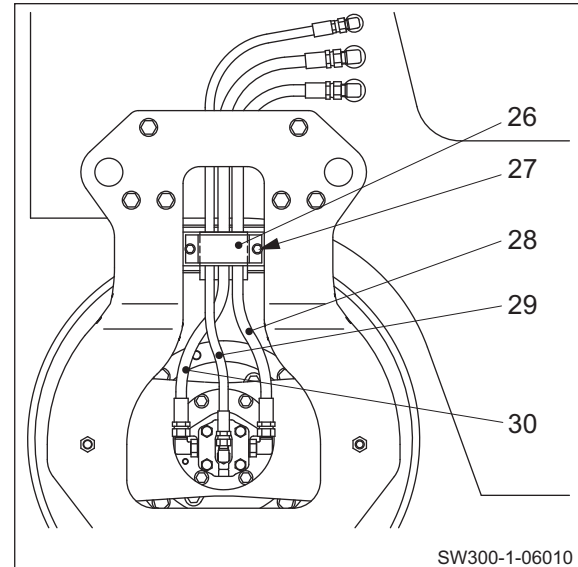

⚠ DANGER

When lifting the machine body, use an appropriate hoist of sufficient strength. Confirm that the surrounding area is safe, and work in a natural, unstrained posture. Also, to firmly secure the machine body, use a support stand of sufficient strength.

- 2) Supporting rear frame
 - Lift plate with a crane.
 - Place support stands under frame when vibratory drum is slightly off ground to support machine body.

\mathfrak{J}_{kg} Rear axle weight

SW300-1 :	1,410 kg (3,110 lbs.)
SW320-1 :	1,490 kg (3,285 lbs.)
SW330-1 :	1,530 kg (3,375 lbs.)

- Flip up scraper blades (31) and (33).
- Remove bolts (32) (left and right sides).

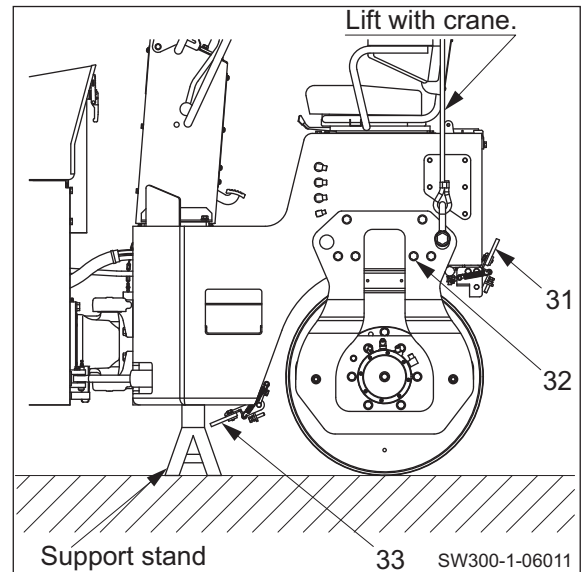

- 3) Removal of vibratory drum
 - Lift left plate (35), right plate (36) and hold them.
 - Lift frame (34) with a crane.
 - Remove vibratory drum together with plates (35), (36) from frame (34).

\mathfrak{J}_{kg} Vibratory drum ASSY

SW300-1 :	600 kg (1,323 lbs.)
SW320-1 :	670 kg (1,477 lbs.)
SW330-1 :	700 kg (1,543 lbs.)

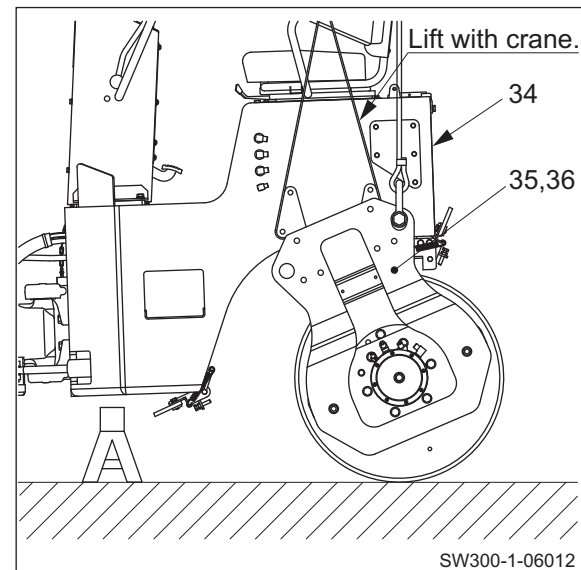

VIBRATORY DRUM - REAR WHEEL

2-1-3. Removal of plate

- 1) Removal of propulsion motor side plate
 - Hold vibratory drum (39) with chocks.
 - Remove nuts (38).
 - Remove plate (19), (35).

 (37) Plate : 45 kg (99 lbs.)

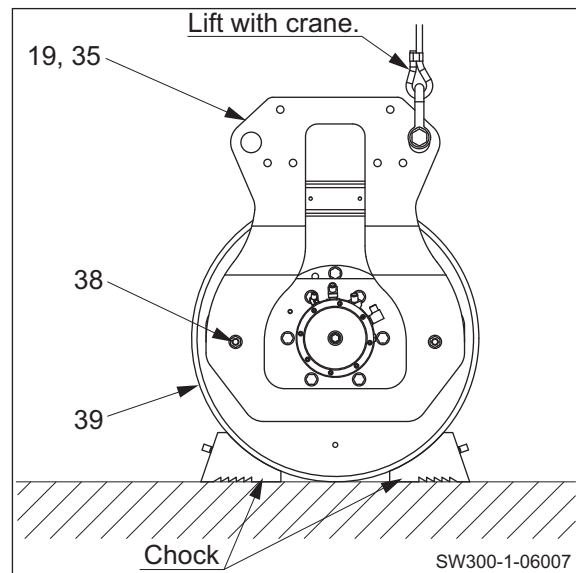

- 2) Removal of vibrator motor side plate
 - Remove nuts (41).
 - Remove plate (18), (36).

 (40) Plate : 45 kg (99 lbs.)

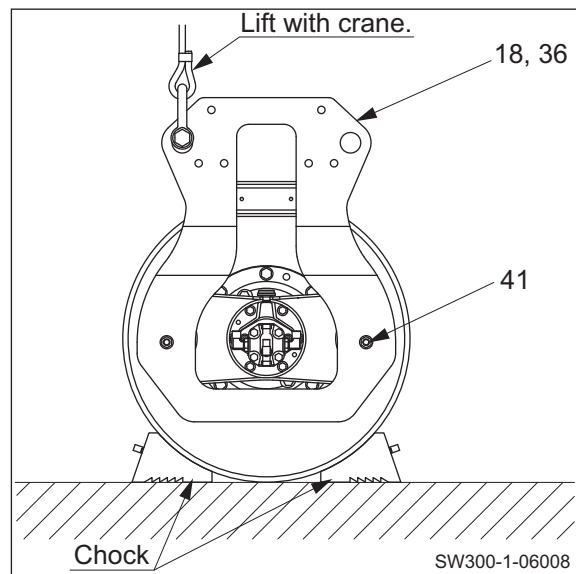

2-1-4. Installation of vibratory drum

- 1) Install vibratory drum in reverse order in which it was removed.
 - Tightening torque for bolts where particular care is required when installing vibratory drum.



- | | | |
|------|----------------|-----------------------------------|
| (3) | Bolt M 8 x 12 | : 23 N·m (17 lbf·ft) |
| (9) | Bolt M 8 x 12 | : 23 N·m (17 lbf·ft) |
| (14) | Bolt M16 x 60 | : 265 N·m (195 lbf·ft) SW300-1 |
| | Bolt M16 x 160 | : 265 N·m (195 lbf·ft) SW/TW320-1 |
| | Bolt M16 x 210 | : 265 N·m (195 lbf·ft) SW/TW330-1 |
| (21) | Bolt M 8 x 12 | : 23 N·m (17 lbf·ft) |
| (27) | Bolt M 8 x 12 | : 23 N·m (17 lbf·ft) |
| (32) | Bolt M16 x 60 | : 265 N·m (195 lbf·ft) SW300-1 |
| | Bolt M16 x 160 | : 265 N·m (195 lbf·ft) SW/TW320-1 |
| | Bolt M16 x 210 | : 265 N·m (195 lbf·ft) SW/TW330-1 |
| (38) | Nut M16 | 196 N·m (145 lbf·ft) |
| (41) | Nut M16 | 196 N·m (145 lbf·ft) |
- 2) Upon installing vibratory drum, pay particular attention to items mentioned below.
 - Fill hydraulic oil tank to specified level to make up for any oil leakage.
 - Start engine and circulate oil through piping. Then check oil level again, ensuring that oil is at specified level.

(NOTICE)

- **If the engine is run at high speed or the cylinder is operated to full stroke when the engine is started for the first time after the work is completed, the piston packing or other items may be damaged by air entering into the cylinder.**

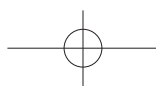
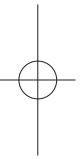
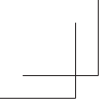

3. VIBRATORY DRUM ASSY

3-1. Vibratory Drum ASSY

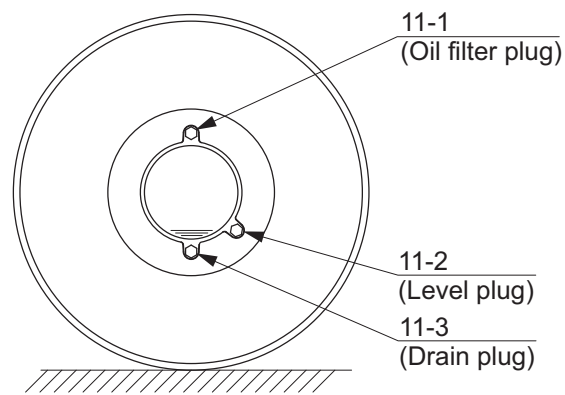
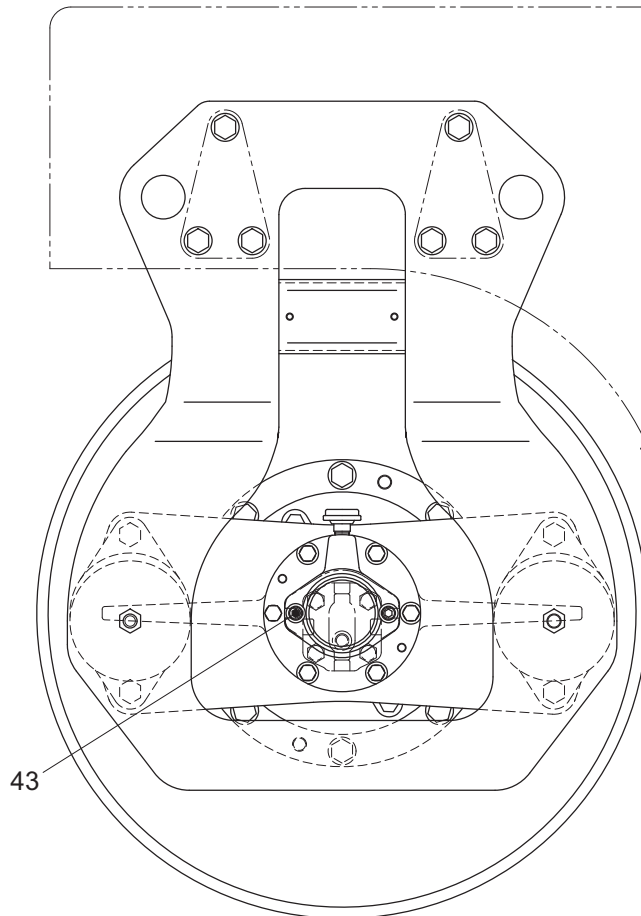
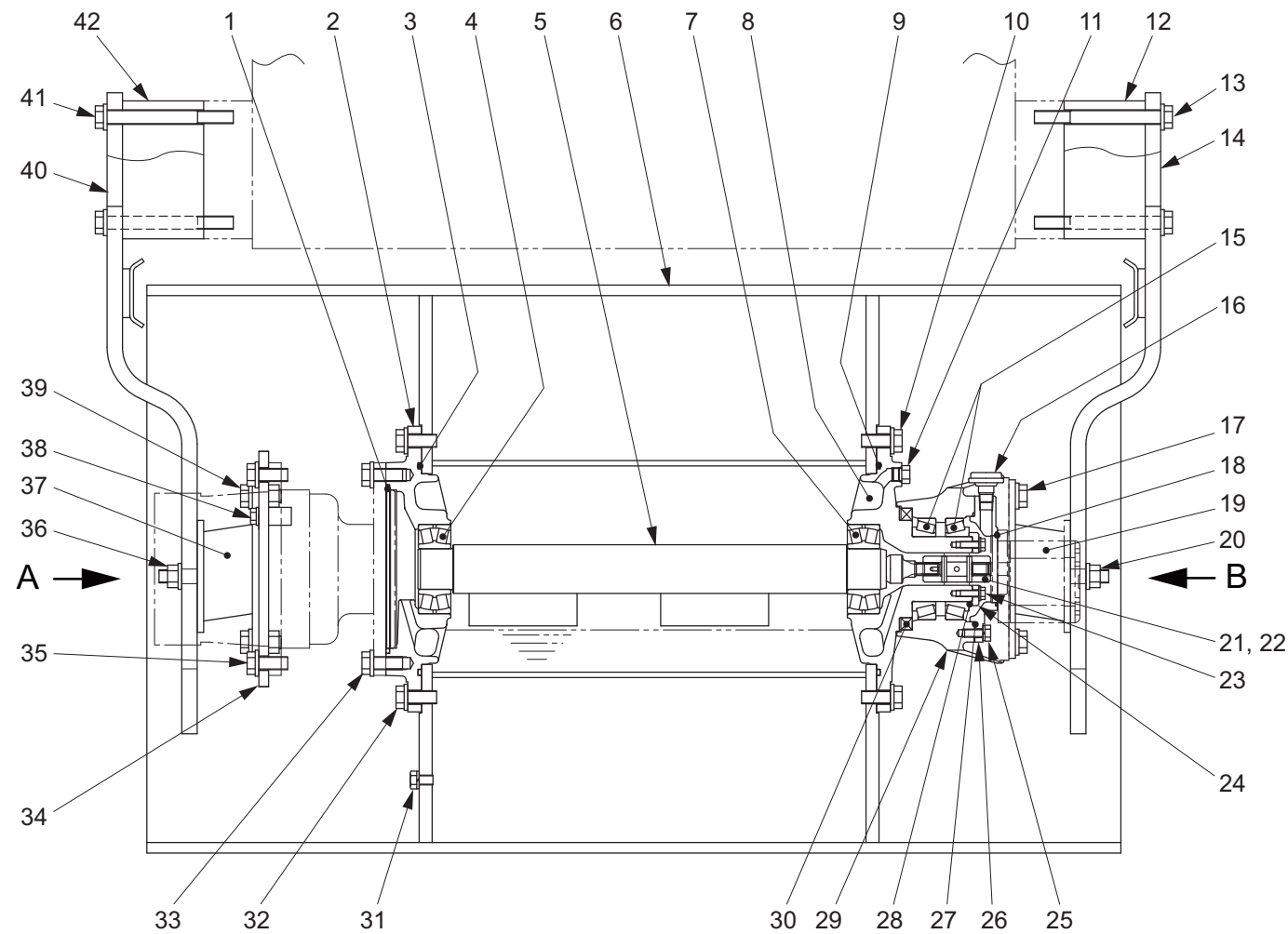

Vibrator motor side

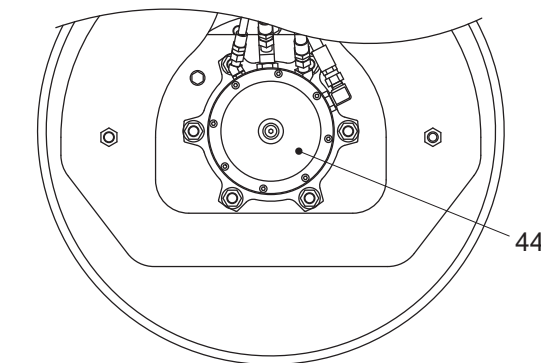

VIEW A

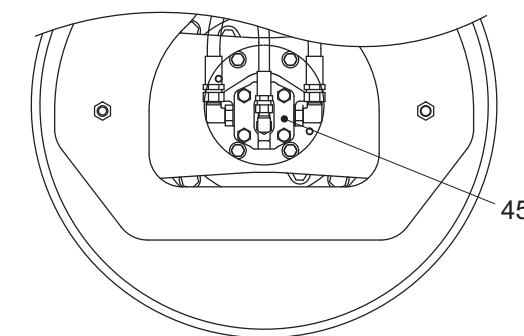

VIEW B

- (1) O-ring
- (2) Holder
- (3) O-ring
- (4) Vibrator bearing
- (5) Eccentric shaft
- (6) Drum
- (7) Vibrator bearing
- (8) Boss
- (9) O-ring
- (10) Bolt : M16x40
- (11) Plug
- (12) Collar : SW/TW320-1, SW/TW330-1
- (13) Bolt : M16x60 SW300-1
: M16x160 SW/TW320-1
: M16x210 SW/TW330-1
- (14) Plate
- (15) Roller bearing
- (16) Breather
- (17) Bolt : M16x40
- (18) O-ring
- (19) Damper
- (20) Nut : M16
- (21) Sleeve
- (22) Spring pin
- (23) Bolt : M8x25
- (24) Cover
- (25) Bolt : M10x25
- (26) Cover
- (27) O-ring
- (28) Shim
- (29) Disc
- (30) Oil seal
- (31) Bolt : M12x20
- (32) Bolt : M16x40
- (33) Bolt : M16x40
- (34) Disc
- (35) Bolt : M16x40
- (36) Nut : M16
- (37) Damper
- (38) Bolt : M10x25
- (39) Bolt : M16x40
- (40) Plate
- (41) Bolt : M16x60 SW300-1
: M16x160 SW/TW320-1
: M16x210 SW/TW330-1
- (42) Collar : SW/TW320-1, SW/TW330-1
- (43) Bolt : M10x35
- (44) Propulsion motor
- (45) Vibrator motor

0445-43803-0-10616-0

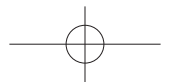
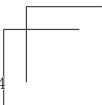
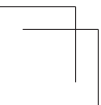
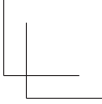
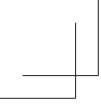

3-2. Disassembly and Reassembly of Vibratory Drum

- Lead line numbers shown in illustrations for following vibratory drum disassembly and reassembly procedures are constant with part numbers of vibratory drum ASSY shown on page 6-010.

3-2-1. Disassembly of vibratory drum

- 1) Lay vibratory drum ASSY with plugs (11-1), (11-2) and (11-3) positioned as shown on the right.
 - Hold with chocks.

 k_g	Vibratory drum ASSY	
	SW300-1	: 515 kg (1,135 lbs.)
	SW/TW320-1	: 585 kg (1,290 lbs.)
	SW/TW330-1	: 615 kg (1,356 lbs.)

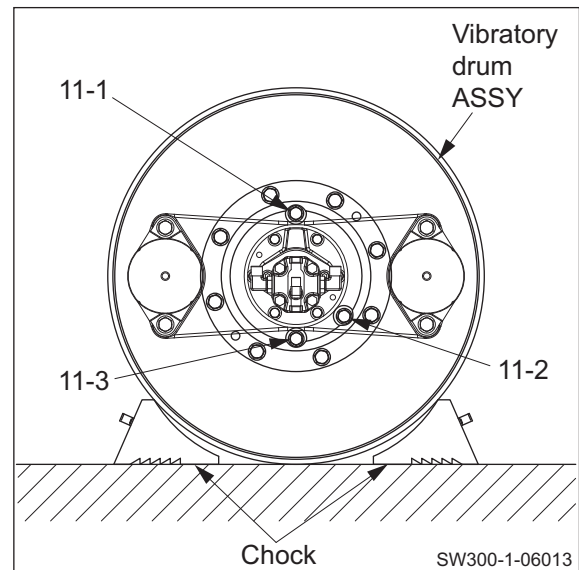

- 2) Remove plugs (11-1) and (11-3).
 - Drain gear oil.

• Quantity of gear oil	SW300-1	: 2.5 L (0.7 gal.)
	SW/TW320-1	: 4.0 L (1.1 gal.)
	SW/TW330-1	: 4.8 L (1.3 gal.)

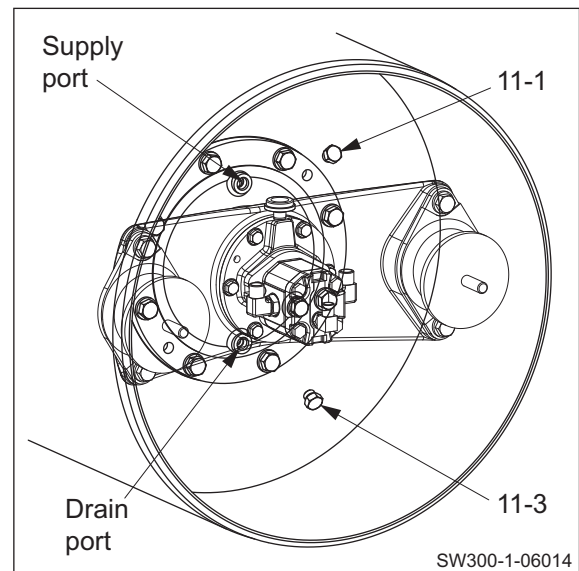

WARNING

- When standing the drum, use wooden blocks of sufficient strength to securely support the drum.
- Carry out the work in an unstrained posture using a work stool or the like.

- 3) Stand vibratory drum ASSY with its vibrator motor (45) side facing up.

 k_g	Vibratory drum ASSY	
	SW300-1	: 515 kg (1,135 lbs.)
	SW/TW320-1	: 580 kg (1,279 lbs.)
	SW/TW330-1	: 610 kg (1,345 lbs.)

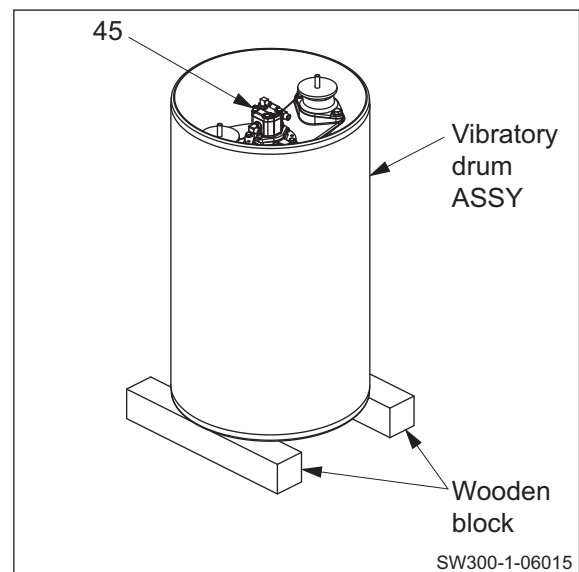

VIBRATORY DRUM - REAR WHEEL

4) Remove adapters.

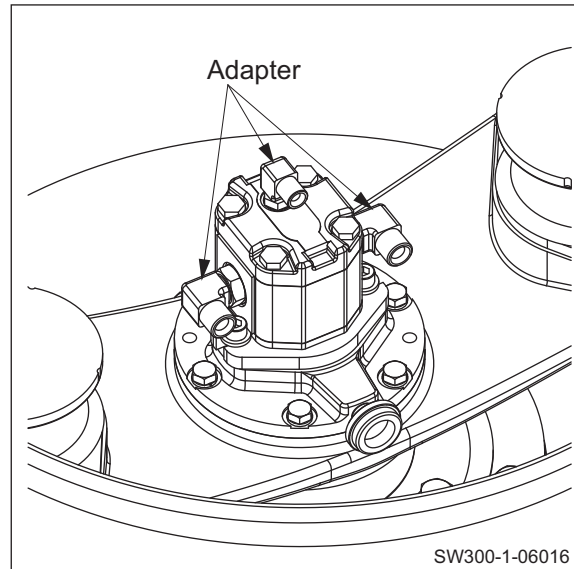

5) Remove bolts (43).

- Remove vibrator motor (45).
- Remove breather (16).

 (45) Vibrator motor : 3 kg (7 lbs.)

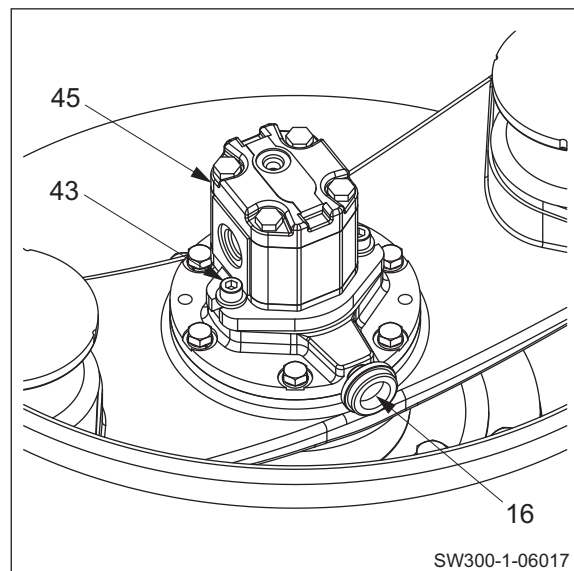

6) Remove sleeve (21).

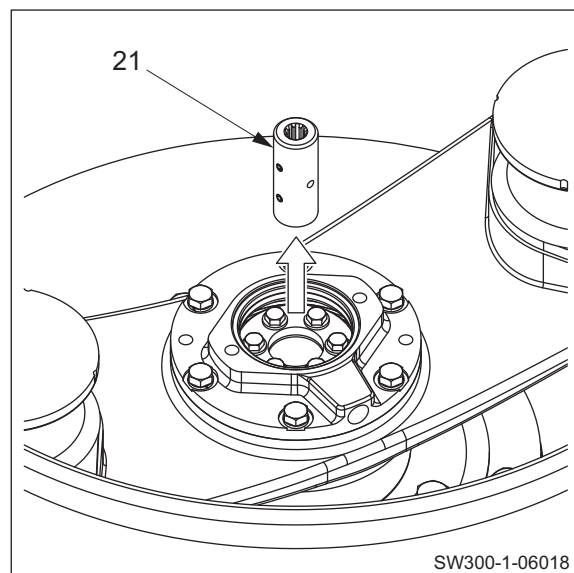

VIBRATORY DRUM - REAR WHEEL

- 7) Remove bolts (25).

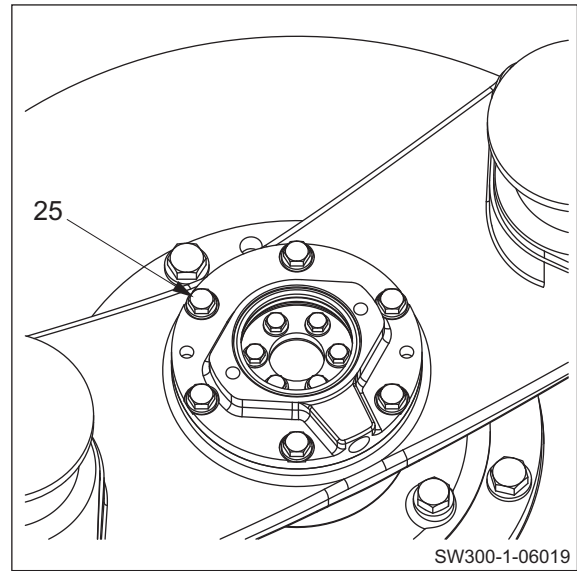

- 8) Lift cover (26) using two pulling bolts (M10×40).
• Remove cover (26).

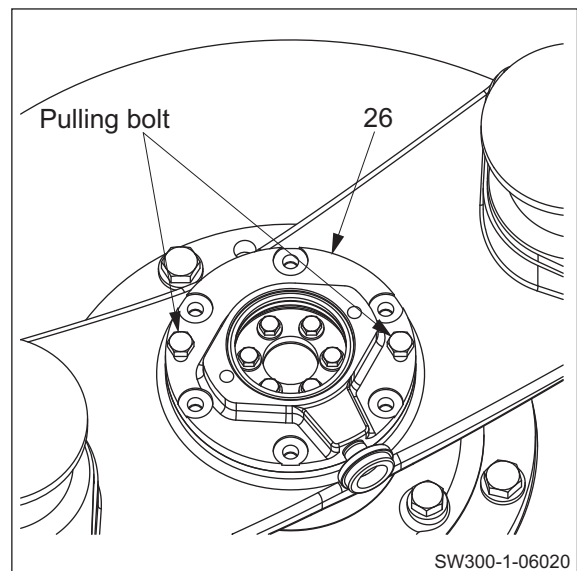

- 9) Remove bolts (17).
• Remove dampers (19).

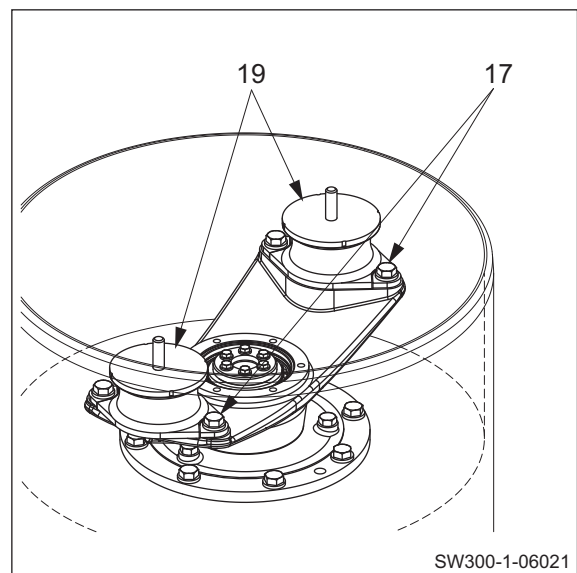

VIBRATORY DRUM - REAR WHEEL

- 10) Remove bolts (23).
- Remove cover (24).
 - Remove shim (28).

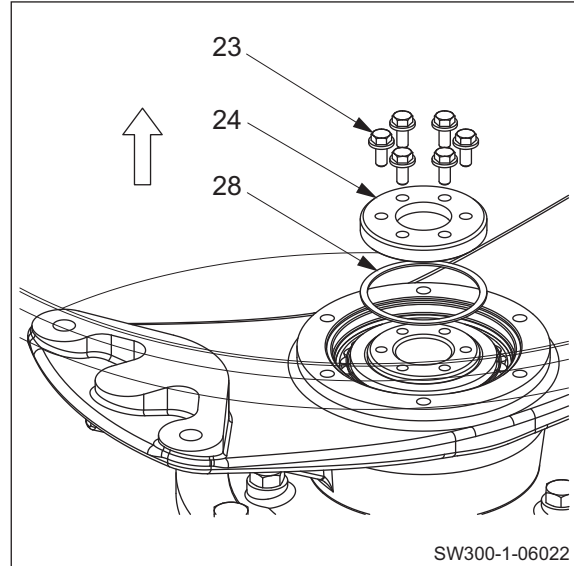

- 11) Put a piece of wooden board on end of boss (8).
- Set a puller on disc (29).
 - Remove disc SUBASSY with roller bearing from boss SUBASSY.

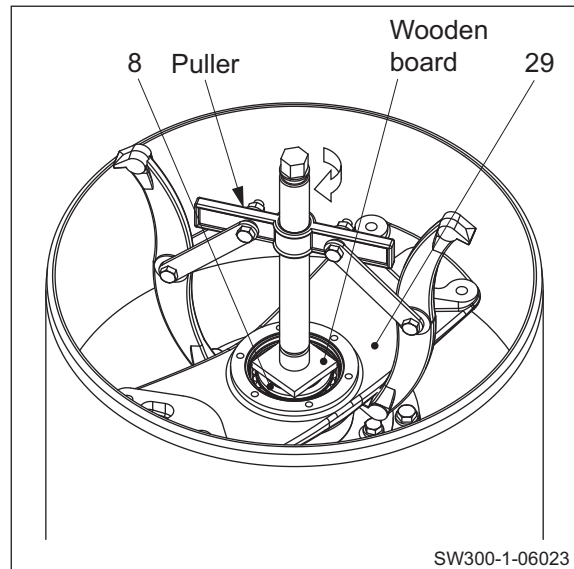

WARNING

When installing lifting bolts, screw in the threads fully before using.

- 12) Install lifting bolts (M16) to disc SUBASSY.

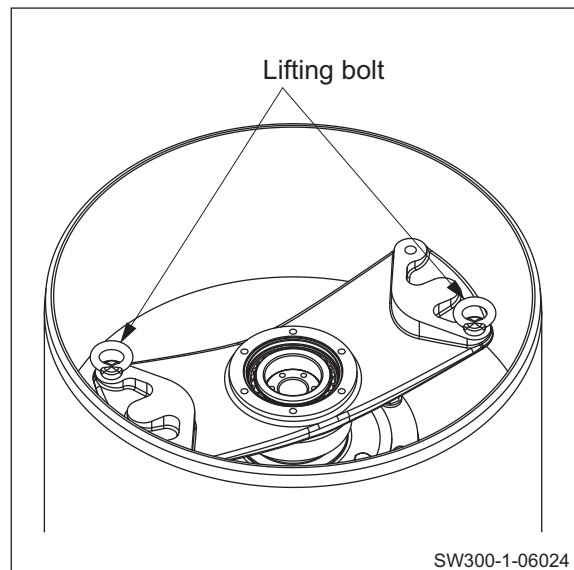

VIBRATORY DRUM - REAR WHEEL

13) Lift disc SUBASSY with roller bearing from boss SUBASSY.

 Disc SUBASSY : 25 kg (55 lbs.)

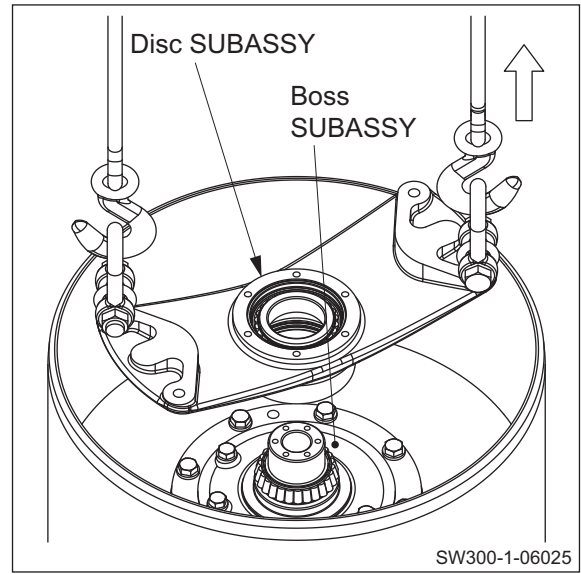

14) Remove bolts (10).

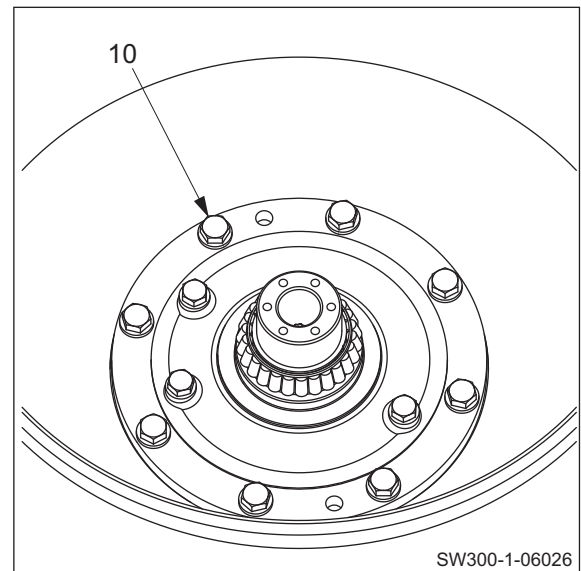

15) Lift boss SUBASSY using two pulling bolts (M16×40).

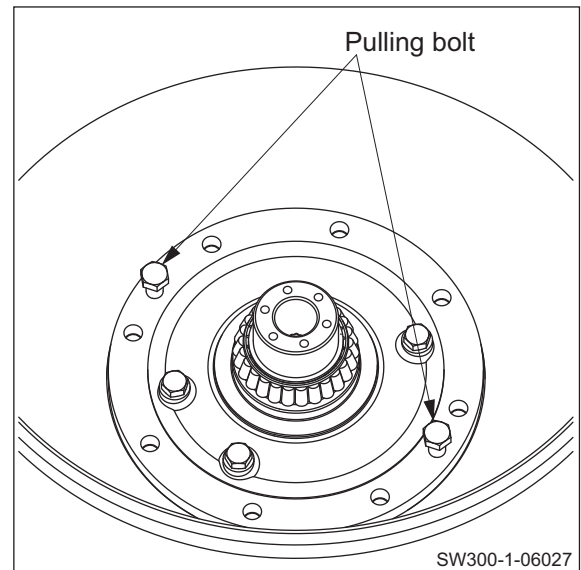

VIBRATORY DRUM - REAR WHEEL

16) Install lifting bolts (M16) to boss SUBASSY.

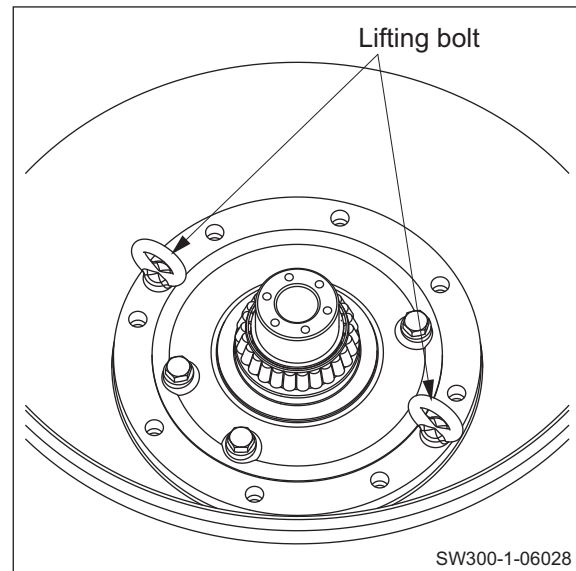

17) Remove boss SUBASSY.

(NOTICE)

- In order not to lift eccentric shaft together with boss SUBASSY, tap on the shaft end with a wooden hammer via a wooden bar during lifting.

 25 kg Boss SUBASSY : 25 kg (55 lbs.)

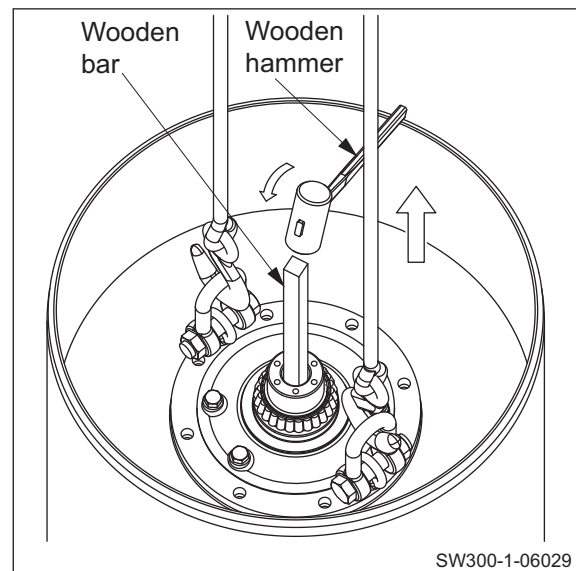

18) Install a lifting bolt (M5) to end of shaft (5).

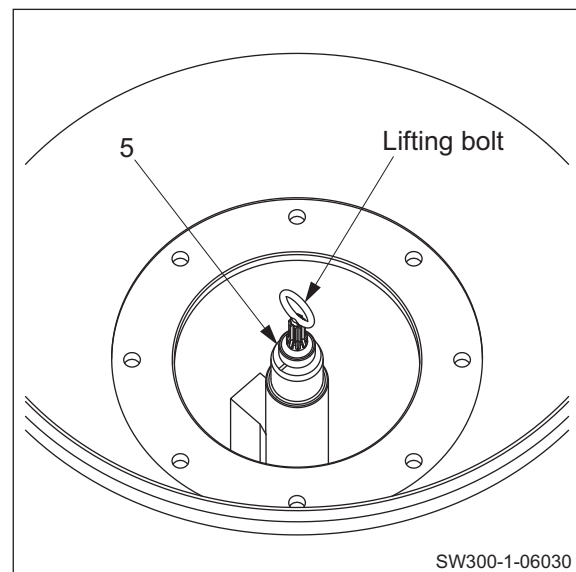

19) Remove eccentric shaft (5).

 (5) Eccentric shaft

- SW300-1 : 15 kg (33 lbs.)
- SW/TW320-1 : 20 kg (44 lbs.)
- SW/TW330-1 : 20 kg (44 lbs.)

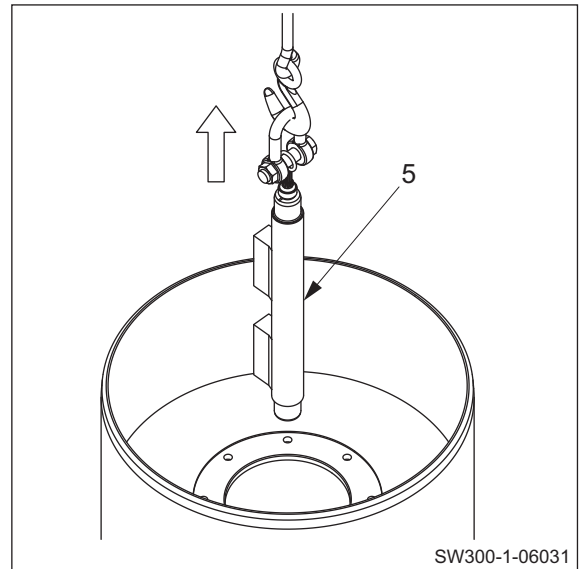

⚠ WARNING

Be careful because reversing the drum involves risk.
Confirm that the surrounding area is safe, and work in a natural, unstrained posture.

20) Reverse drum SUBASSY.

 Drum SUBASSY

- SW300-1 : 440 kg (970 lbs.)
- SW/TW320-1 : 500 kg (1,102 lbs.)
- SW/TW330-1 : 525 kg (1,157 lbs.)

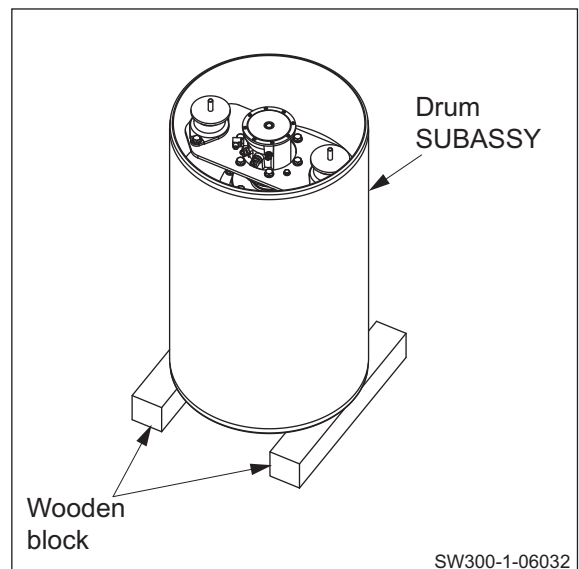

21) Remove adapters.

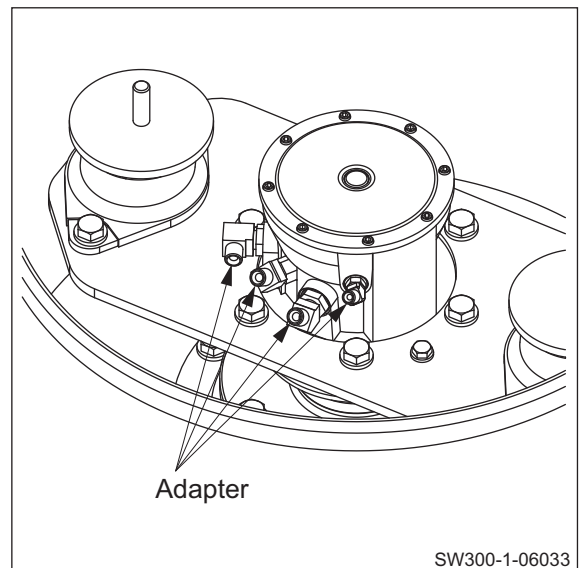

VIBRATORY DRUM - REAR WHEEL

22) Lift disc SUBASSY.

- Remove bolts (39).

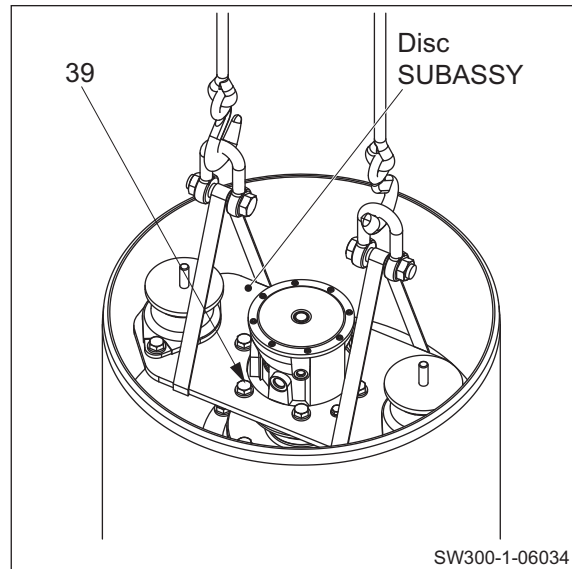

23) Remove disc SUBASSY.

\mathfrak{J}_{kg} Disc SUBASSY : 20 kg (44 lbs.).

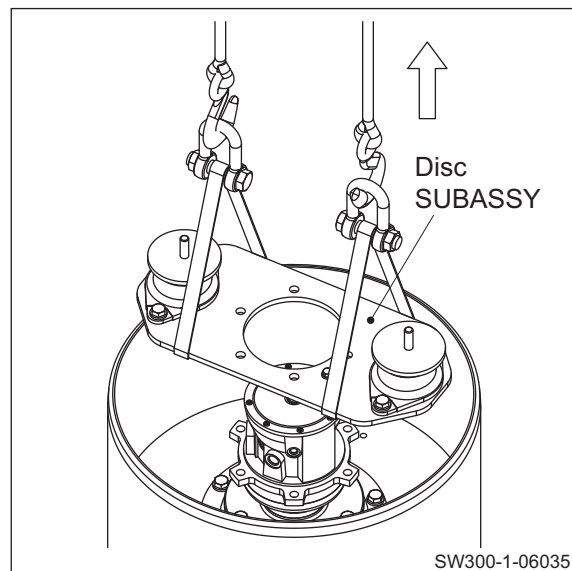

24) Install lifting bolts (M16) to propulsion motor (44).

- Remove bolts (33).

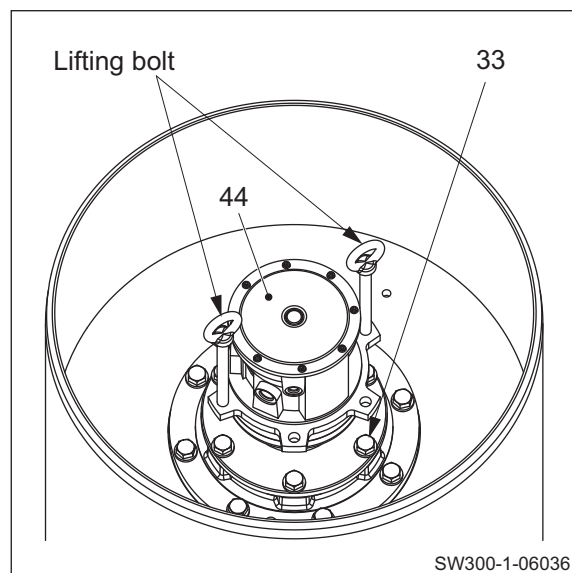

VIBRATORY DRUM - REAR WHEEL

25) Remove propulsion motor (44).

 (44) Propulsion motor : 45 kg (99 lbs.)

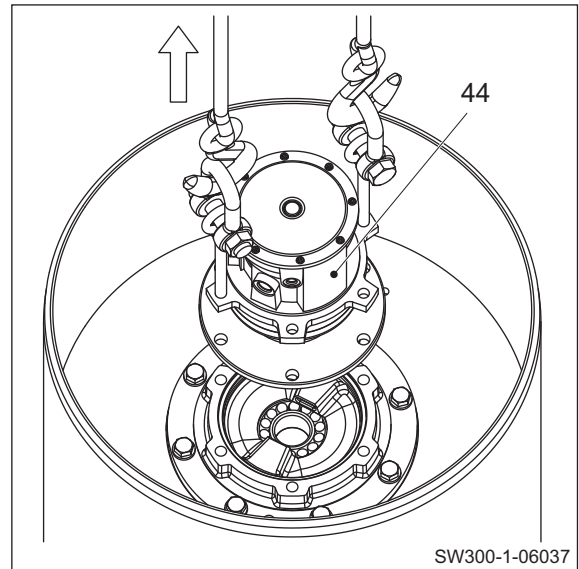

26) Remove bolts (32).

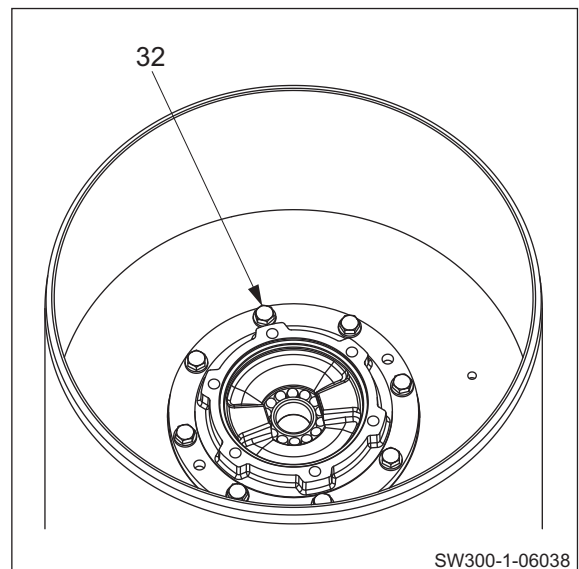

27) Lift holder SUBASSY using two pulling bolts (M16×40).

- Remove holder SUBASSY.

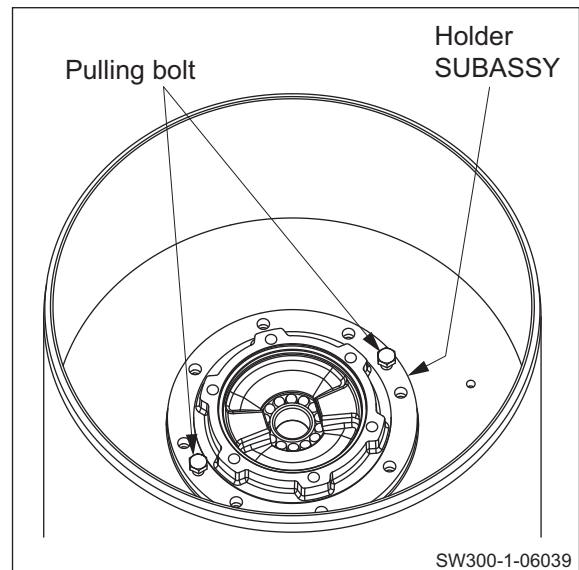

VIBRATORY DRUM - REAR WHEEL

28) Install lifting bolts (M16) to holder SUBASSY.

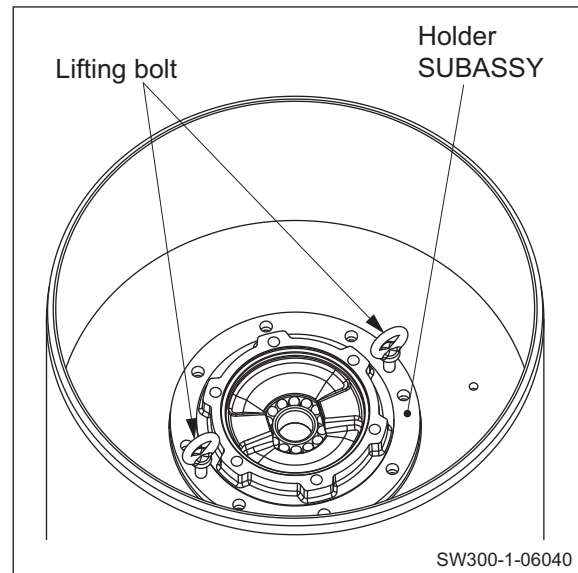

29) Remove holder SUBASSY from drum.

- Remove vibrator bearing (4).

 20 kg Holder SUBASSY : 20 kg (44 lbs.)

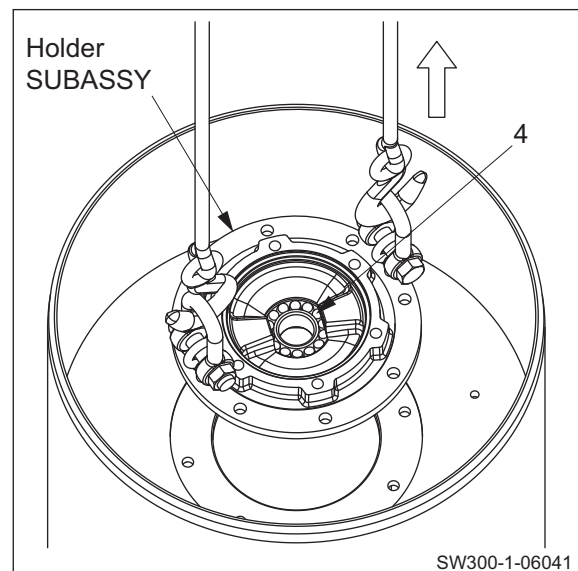

3-2-2. Reassembly of vibratory drum

- Before reassembling, clean disassembled parts well and check that there is no abnormality.

⚠ WARNING

- When standing the drum, use wooden blocks of sufficient strength to securely support the drum.
- Carry out the work in an unstrained posture using a work stool or the like.

- 1) Stand drum (6) with its propulsion motor side facing up.

 (6) Drum

SW300-1	: 350 kg (772 lbs.)
SW/TW320-1	: 410 kg (904 lbs.)
SW/TW330-1	: 435 kg (959 lbs.)

(NOTICE)

- Direction with tapping hole (M12) is propulsion motor side.

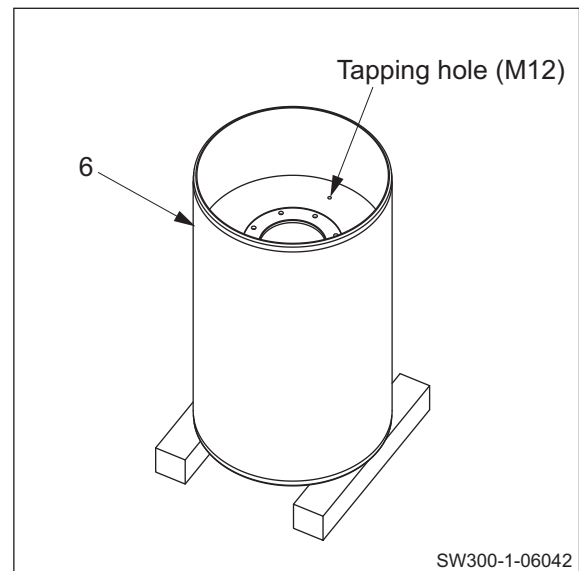

- 2) Reassembly of holder SUBASSY
 - 2-1) Apply a coat of gear oil to holder (2) at where bearing will be press-fitted.
 - Drive in vibrator bearing (4).

(NOTICE)

- Take care not to damage the bearing when installing it.

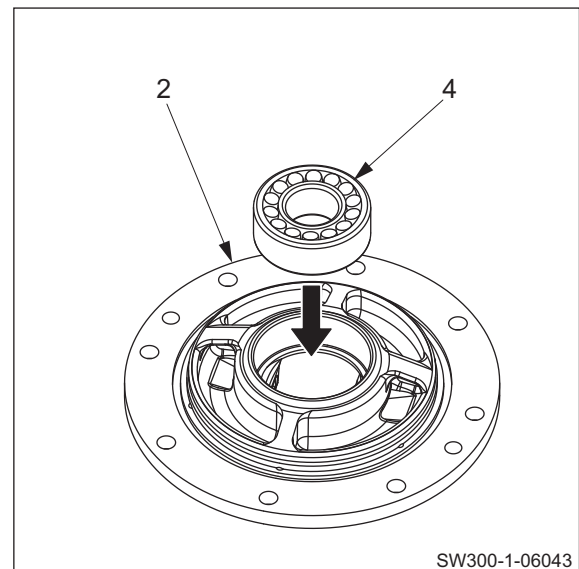

VIBRATORY DRUM - REAR WHEEL

2-2) Apply grease to O-ring (3).

- Install O-ring (3) to holder SUBASSY.

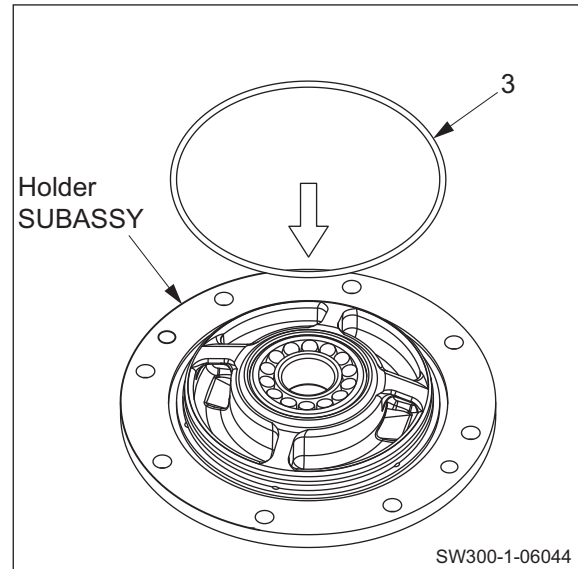

3) Reverse holder SUBASSY.

 Holder SUBASSY : 20 kg (44 lbs.)

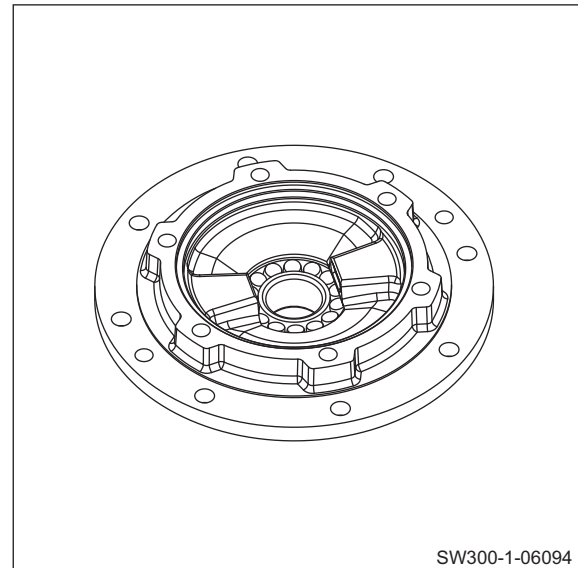

WARNING

When installing lifting bolts, screw in the threads fully before using.

- Install lifting bolts (M16) to holder SUBASSY.

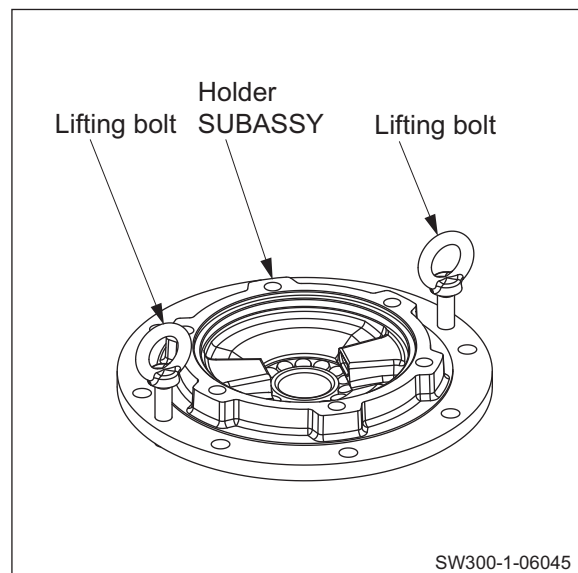

VIBRATORY DRUM - REAR WHEEL

- 4) Lower holder SUBASSY on mounting surface of drum (6).

 Holder SUBASSY : 20 kg (44 lbs.)

(NOTICE)

- Take care not to let O-ring to protrude from its groove.

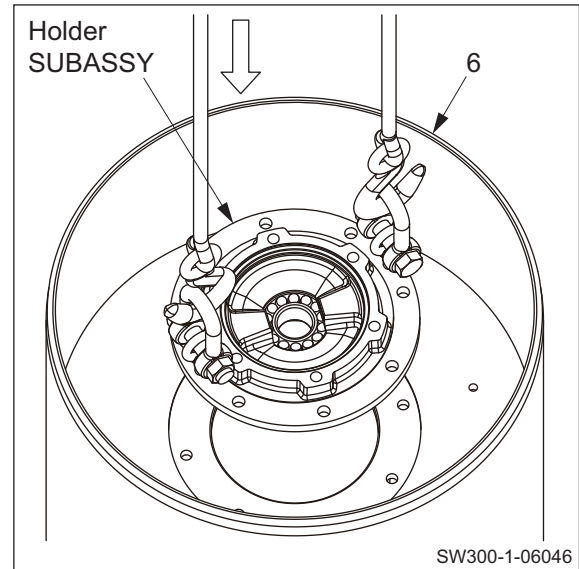

- 5) Secure holder SUBASSY with eight bolts (32) and washers.

 (32) Bolts M16×40 : 265 N·m (195 lbf·ft)

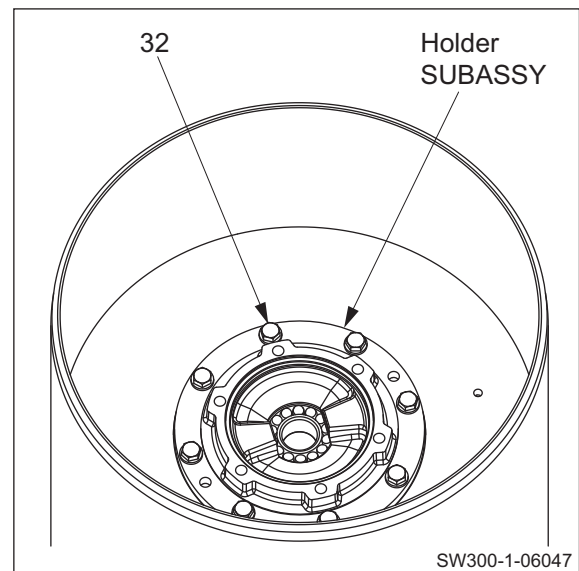

- 6) Install lifting bolts (M16) to propulsion motor (44).

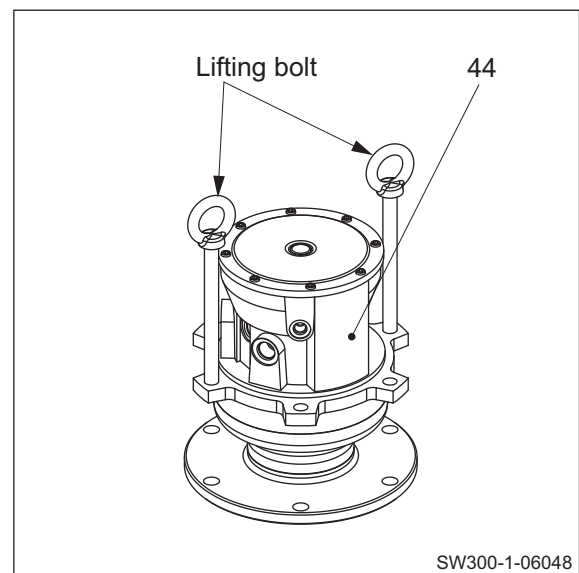

VIBRATORY DRUM - REAR WHEEL

- 7) Apply grease to O-ring (1).
• Install O-ring (1) to propulsion motor (44).

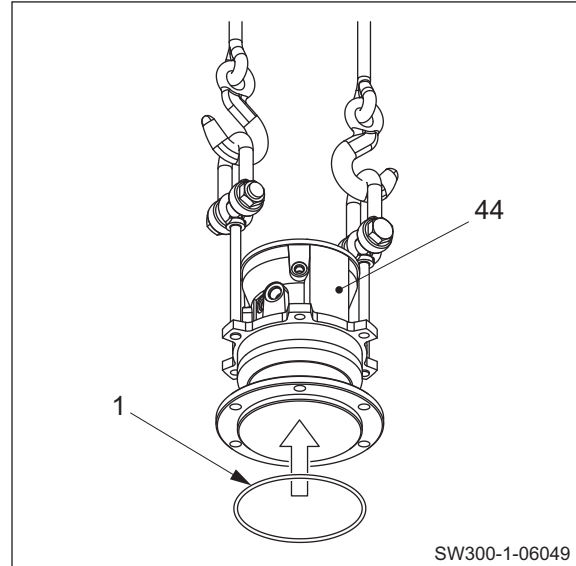

- 8) Lower propulsion motor (44) on mounting surface of holder SUBASSY.

 (44) Propulsion motor : 45 kg (99 lbs.)

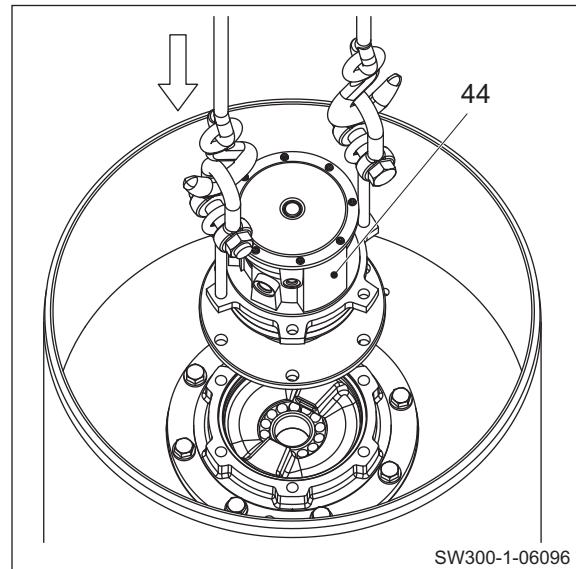

- 9) Secure propulsion motor (44) with six bolts (33) and washers.

 (33) Bolts M16×40 : 265 N·m (195 lbf·ft)

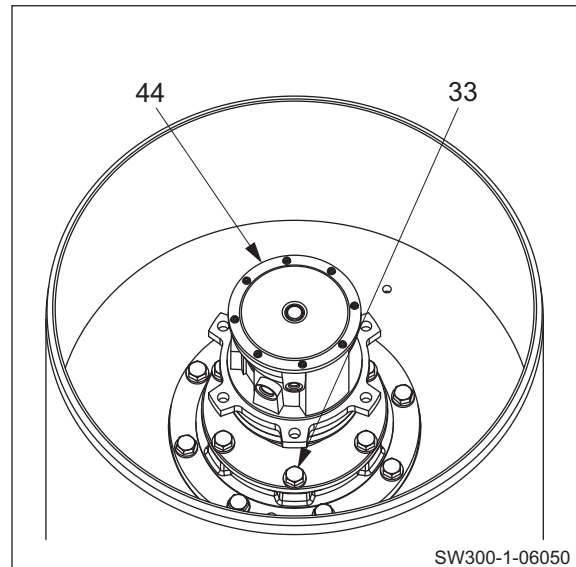

VIBRATORY DRUM - REAR WHEEL

10) Lift disc SUBASSY.

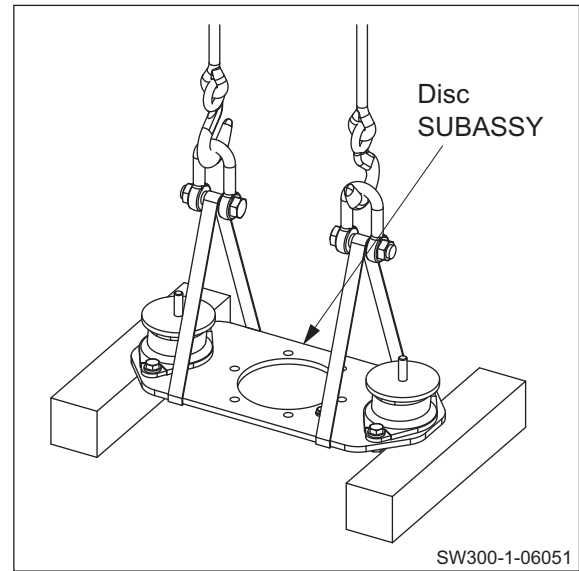

11) Lower disc SUBASSY on mounting surface of propulsion motor (44).

 Disc SUBASSY : 20 kg (44 lbs.)

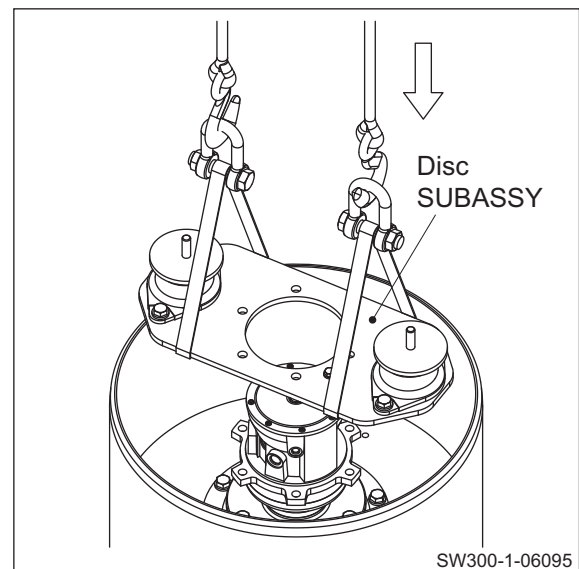

(NOTICE)

- The longer direction of the disc must be parallel with the side of the propulsion motor port A.

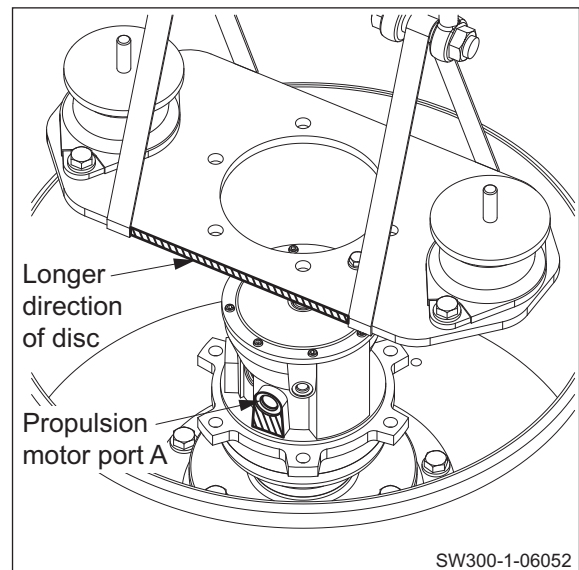

VIBRATORY DRUM - REAR WHEEL

12) Secure disc SUBASSY with six bolts (35) and washers.

 N·m (35) Bolt M16×40 : 265 N·m (195 lbf·ft)

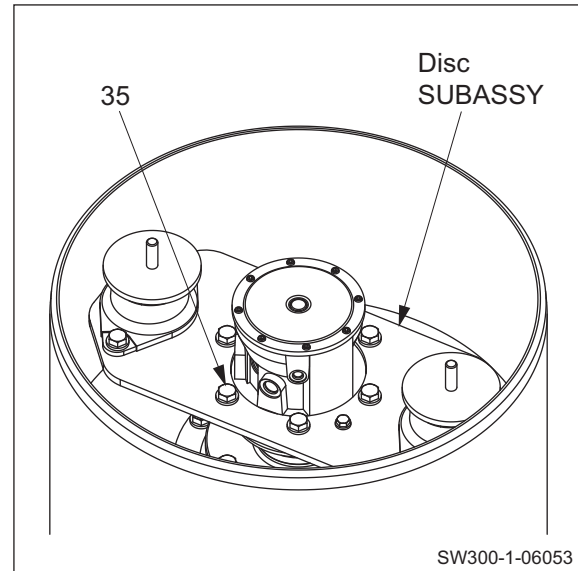

13) Apply grease to O-rings for adapters.

- Install adapters.

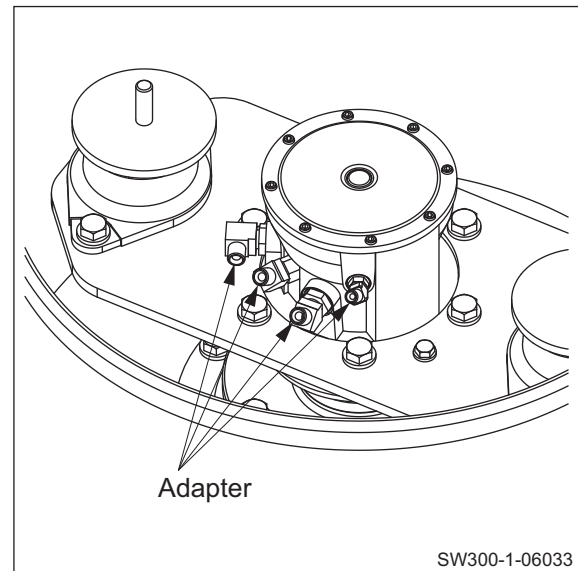

WARNING

Be careful because reversing the drum involves risk.
Confirm that the surrounding area is safe, and work in a natural, unstrained posture.

14) Reverse drum SUBASSY.

 kg Drum SUBASSY

SW300-1 : 440 kg (970 lbs.)

SW/TW320-1 : 500 kg (1,102 lbs.)

SW/TW330-1 : 525 kg (1,157 lbs.)

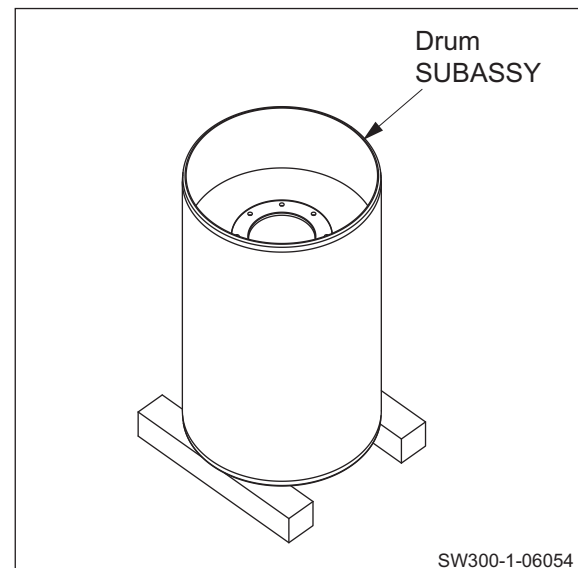

15) Install a lifting bolt (M5) to end of eccentric shaft (5).

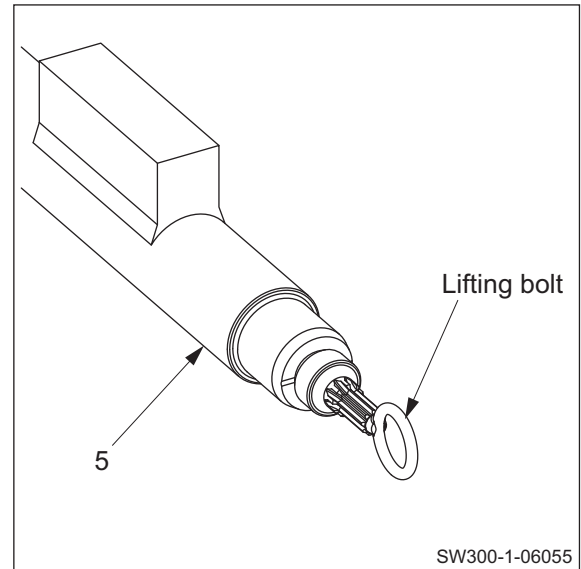

16) Apply a coat of gear oil to eccentric shaft (5) at where bearing will be installed.

- Lower eccentric shaft (5).

\mathfrak{J}_{kg} (5) Eccentric shaft

SW300-1	:	15 kg (33 lbs.)
SW/TW320-1	:	20 kg (44 lbs.)
SW/TW330-1	:	20 kg (44 lbs.)

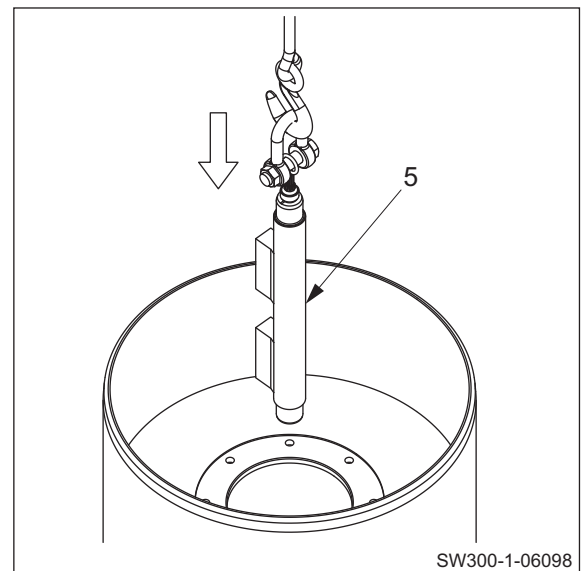

17) Insert eccentric shaft (5) into vibrator bearing (4) while taking care not to tilt vibrator bearing inner race.

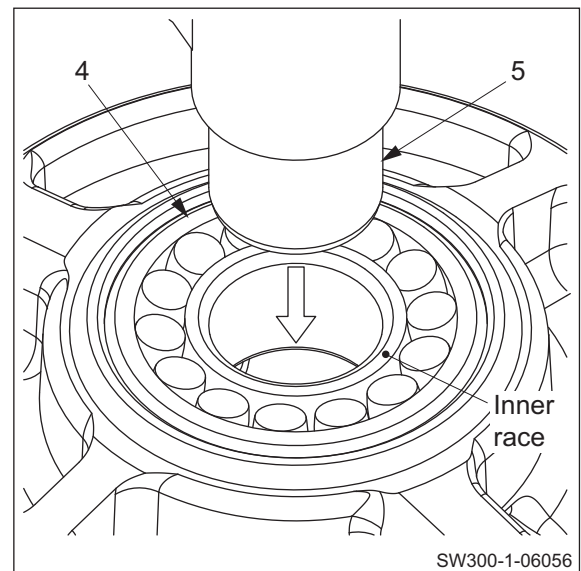

VIBRATORY DRUM - REAR WHEEL

18) Reassembly of boss SUBASSY

18-1) Apply a coat of gear oil to boss (8) at where bearing will be press-fitted.

- Drive in vibrator bearing (7).

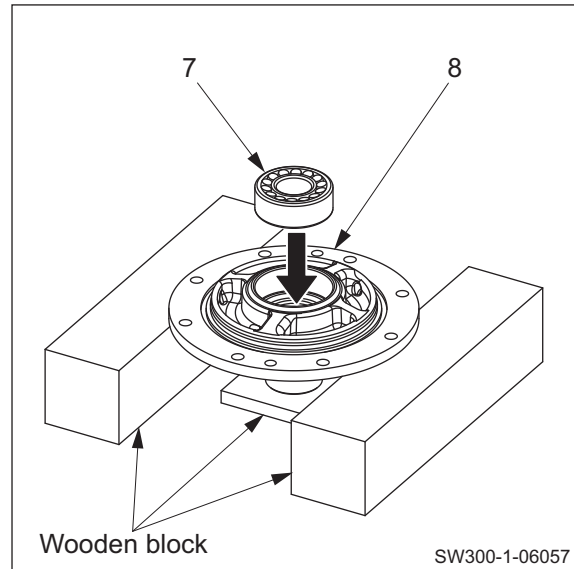

18-2) Reverse boss SUBASSY.

 Boss SUBASSY : 25 kg (55 lbs.)

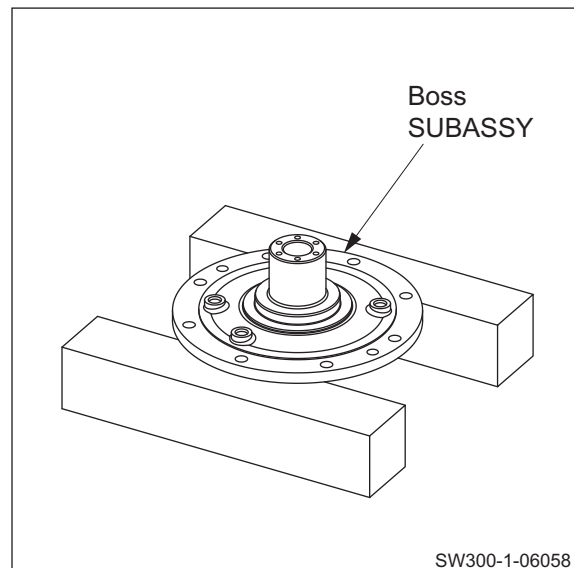

WARNING

Wear heat resistant gloves when handling heated parts to avoid burns.

18-3) Heat up roller bearing (15) inner race by using a ring heater or the like.

- Apply a coat of gear oil to boss SUBASSY at where bearing inner will be press-fitted.
- Drive in heated roller bearing (15) inner race.

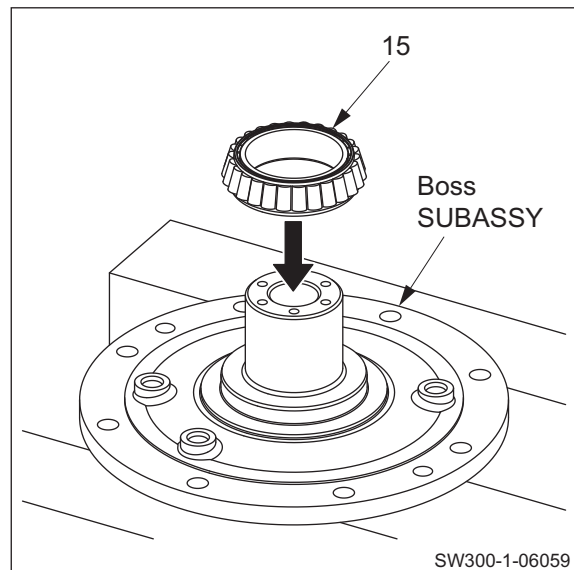

VIBRATORY DRUM - REAR WHEEL

- 18-4) Apply grease to O-rings for plugs (11).
- Install plugs (11).

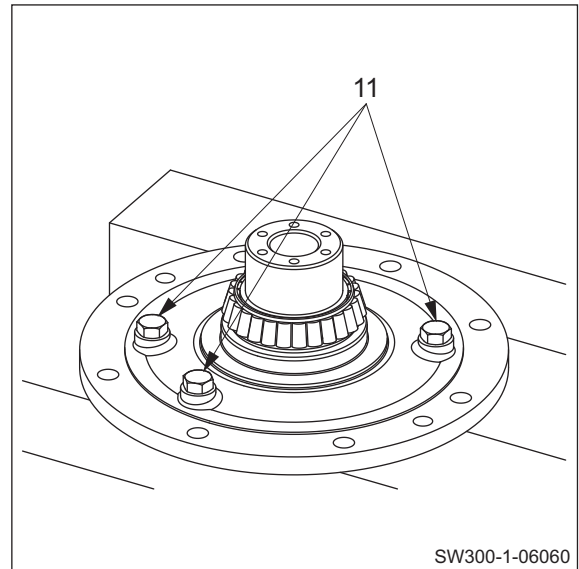

- 19) Install lifting bolts (M16) to boss SUBASSY.

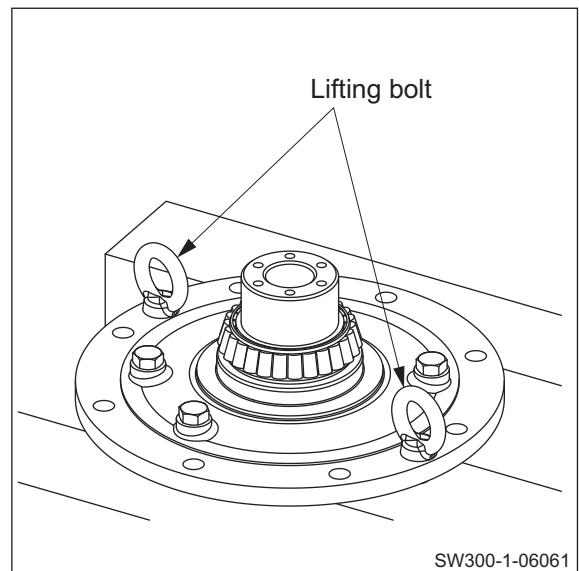

- 20) Lift boss SUBASSY.

- Apply grease to O-ring (9).
- Install O-ring (9) to boss SUBASSY.

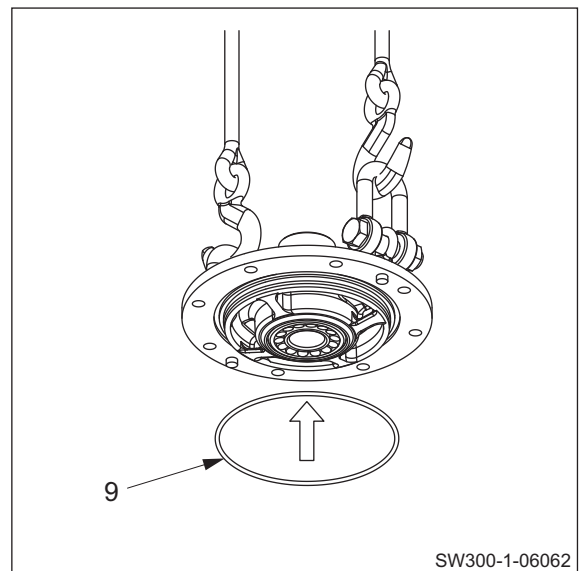

VIBRATORY DRUM - REAR WHEEL

21) Lower boss SUBASSY on mounting surface of drum SUBASSY slowly.

 Boss SUBASSY : 25 kg (55 lbs.)

(NOTICE)

- Support shaft (5) with a pipe or the like, to prevent tilting of vibrator bearing inner race during installation.

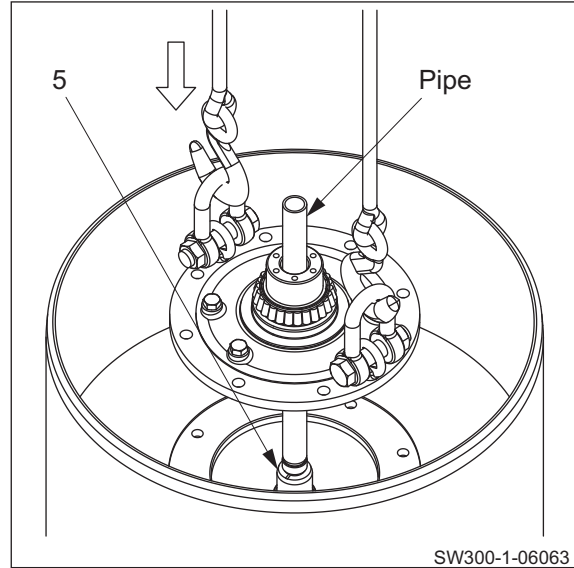

22) Secure boss SUBASSY with eight bolts (10) and washers.

 (10) Bolts M16×40 : 265 N·m (195 lbf·ft)

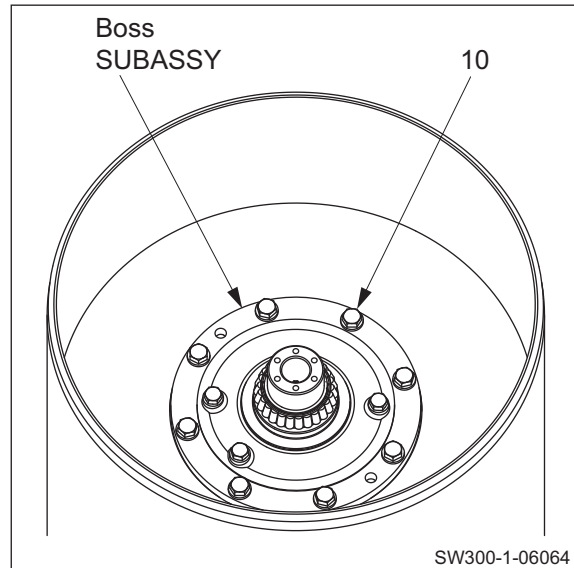

23) Install a lifting bolt (M5) to end of shaft (5).

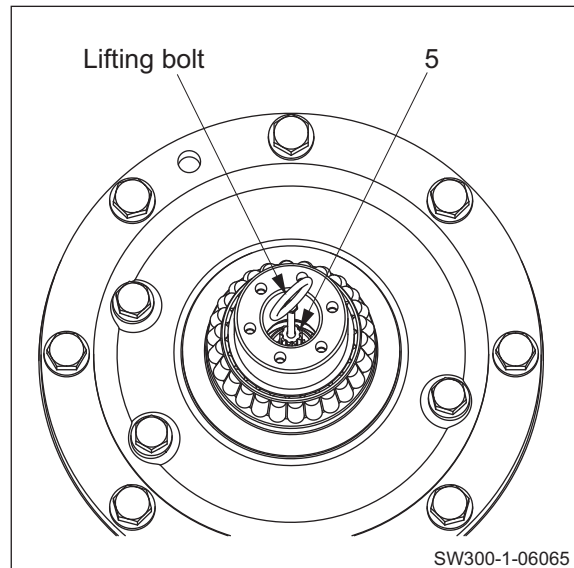

VIBRATORY DRUM - REAR WHEEL

24) Slowly lift shaft (5) with a crane and check that there is an axial play of 2 to 4 mm (0.08 to 0.16 in.).

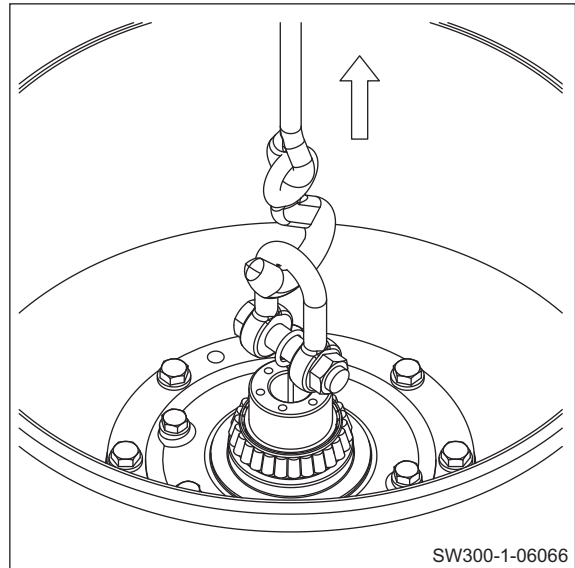

25) Apply a coat of gear oil to disc (29) at where bearing outer races will be press-fitted.

- Drive roller bearings (15) outer races into disc (29).
- Apply liquid packing to periphery of oil seal (30).
- Drive in oil seal (30).
- Apply grease to lip of oil seal (30).

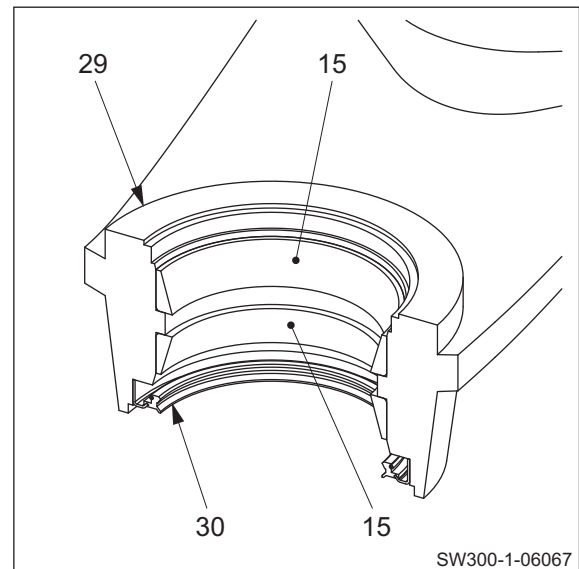

26) Install lifting bolts (M16) to disc SUBASSY.

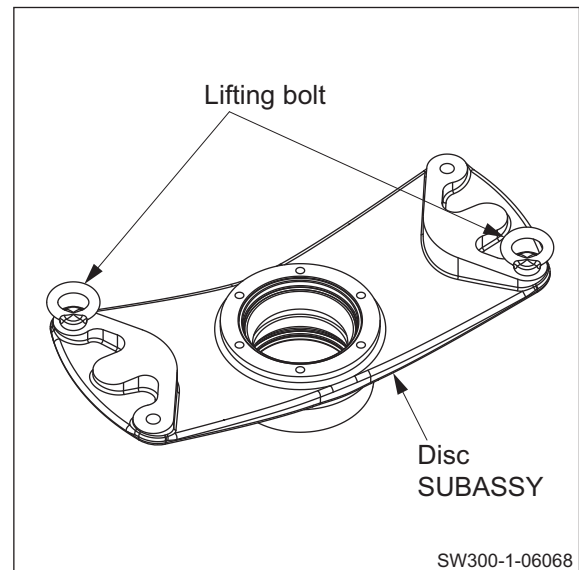

VIBRATORY DRUM • REAR WHEEL

27) Lower disc SUBASSY on mounting surface of boss SUBASSY.

- Apply sufficient amount of lithium-based grease to rollers of roller bearing (15) inner race.

\mathfrak{J}_{kg} Disc SUBASSY : 25 kg (55 lbs.)

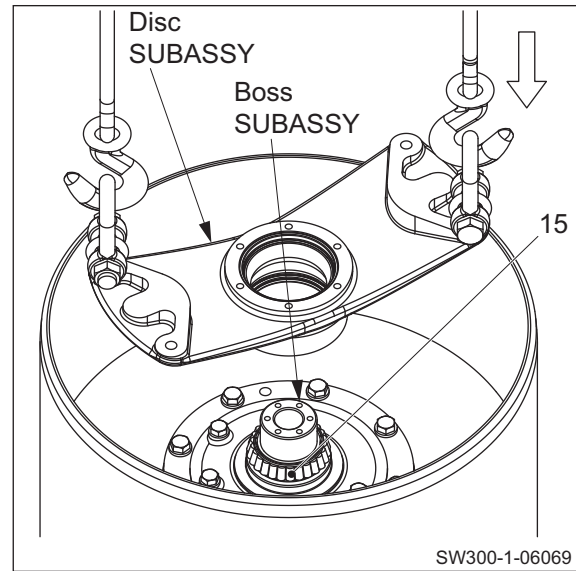

28) Apply sufficient amount of lithium-based grease to rollers of roller bearing (15) inner race.

- Drive in roller bearing (15) inner race until rollers come in contact with outer race.

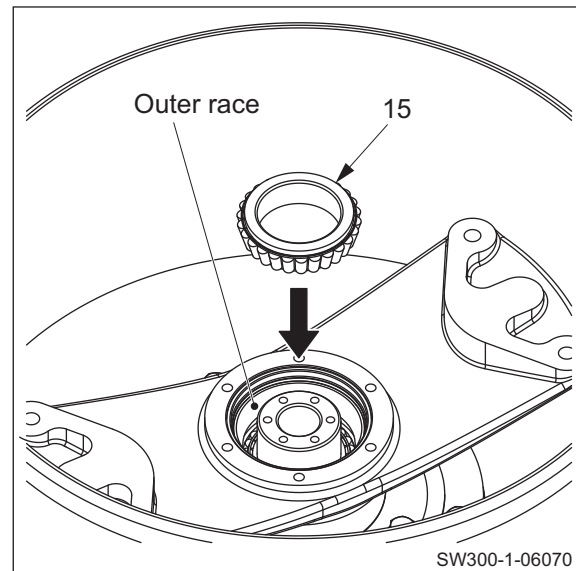

29) Preload adjustment of roller bearing

- ① Install a shim of about 1 mm (0.04 in.) and secure cover (24) to boss SUBASSY with three bolts (23) and washers.

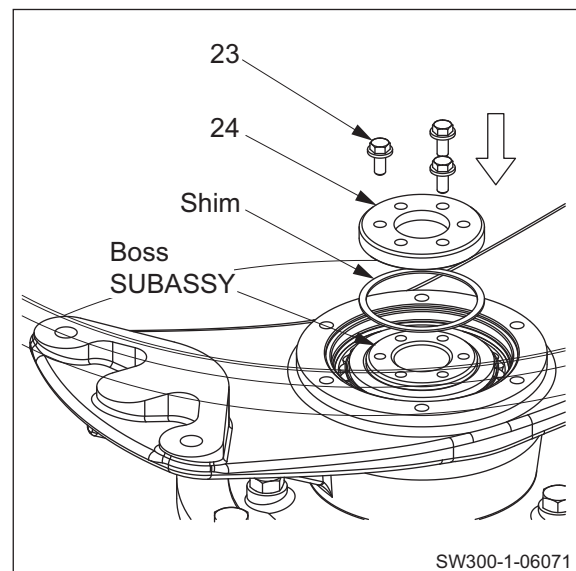

VIBRATORY DRUM • REAR WHEEL

- ② A gap will remain between end of boss SUBASSY and inside of cover (24).
- Tighten bolts (23) to a torque of 7.8 N·m (6 lbf·ft).
 - Give disc SUBASSY two to three turns.
 - Tighten bolts (23) to a torque of 7.8 N·m (6 lbf·ft) again.
 - Repeat this work several times until tightening torque of bolts no longer fluctuates.

(NOTICE)

- Tighten bolts alternately in diagonal directions.

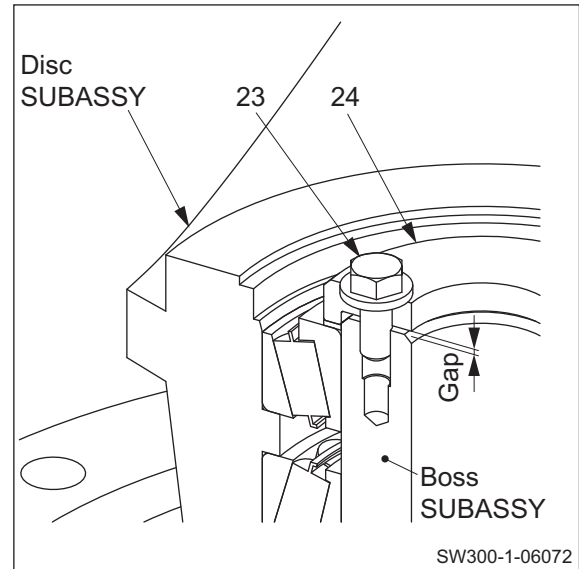

(NOTICE)

- It is necessary to rotate the bearing to lift the rollers while pressing in the inner race. Otherwise the bearing will not seat no matter how forcibly the inner race is pressed.

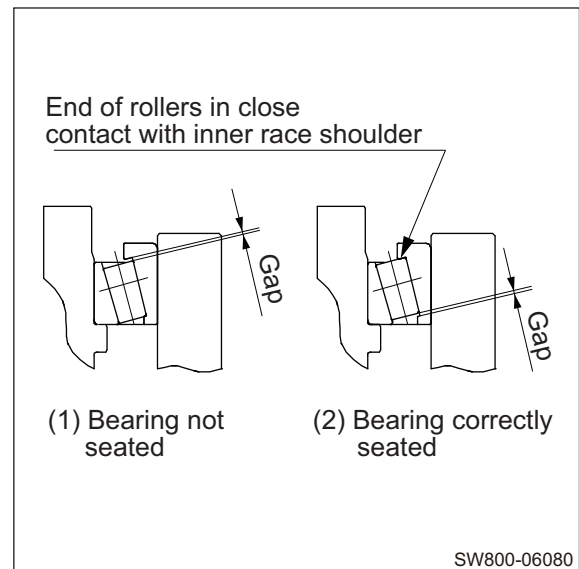

- ③ Remove bolts (23).
- Remove cover (24).
 - Remove shim.

(NOTICE)

- Do not turn the disc SUBASSY after the cover is removed.

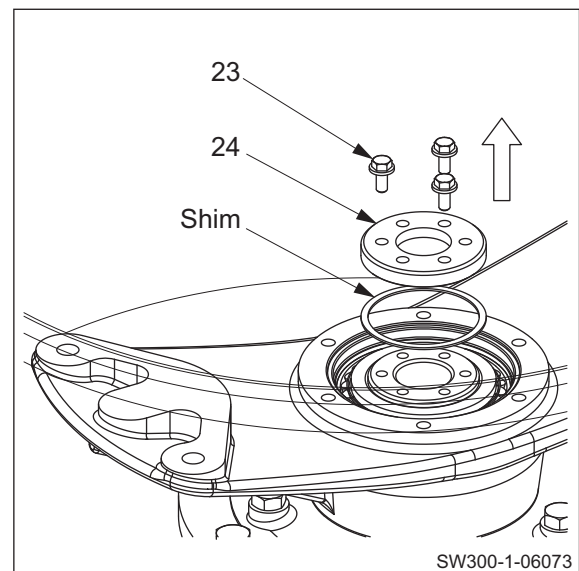

VIBRATORY DRUM - REAR WHEEL

- ④ Without inserting shim, install cover (24) to boss SUBASSY with three bolts (23) and washers.

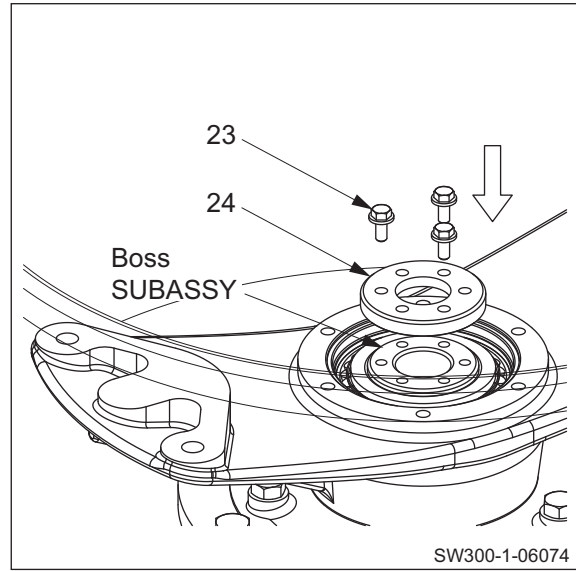

- ⑤ Using a thickness gauge, measure clearance "A".

★ Preload adjusting shim thickness = $A + 0.1 \text{ mm (0.04 in.)}$

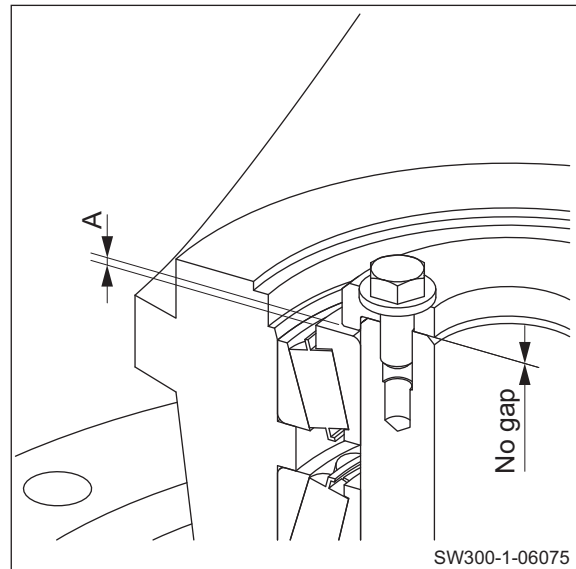

- ⑥ Remove bolts (23).
• Remove cover (24).

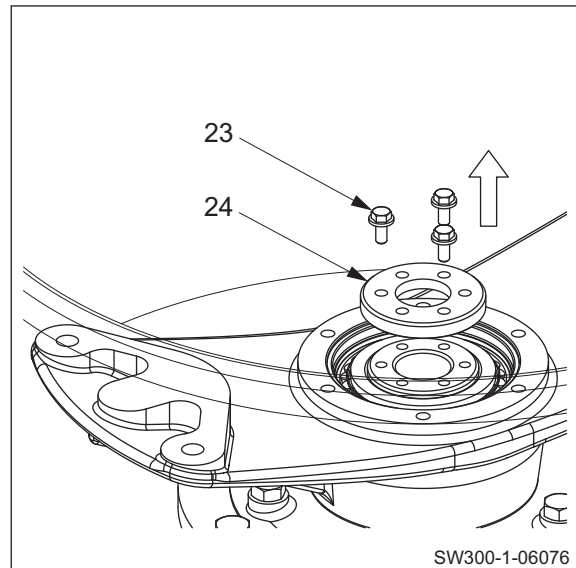

VIBRATORY DRUM - REAR WHEEL

- ⑦ Install shim of preload adjusting shim (28) thickness = "A + 0.1 mm (0.04 in.)".
- Secure cover (24) to boss SUBASSY with six bolts (23) and washers.

 N·m (23) Bolts M8×25 : 31 N·m (23 lbf·ft)

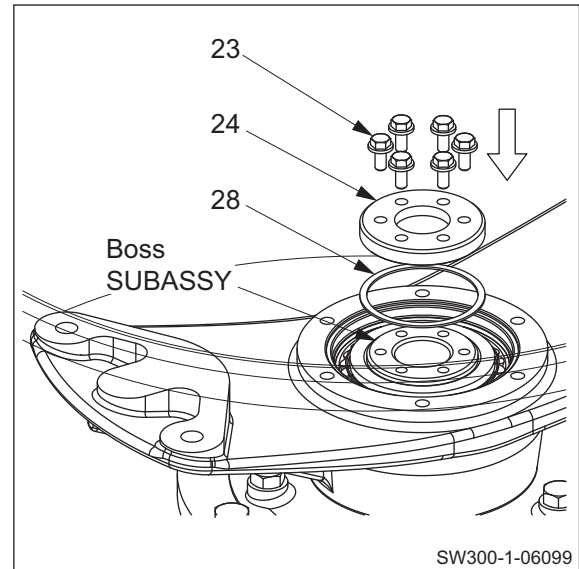

- 30) Apply grease to O-ring (18).
- Install O-ring (18) to cover (26).

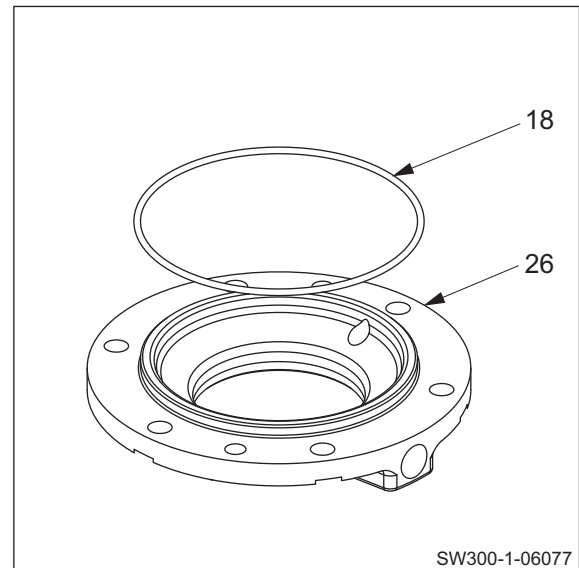

- 31) Secure cover (26) to disc SUBASSY with six bolts (25) and spring washers.

 N·m (25) Bolts M10×25 : 49 N·m (36 lbf·ft)

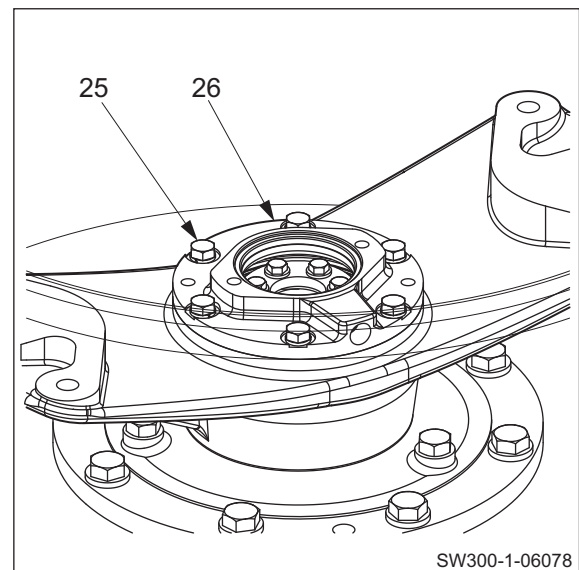

VIBRATORY DRUM - REAR WHEEL

32) Secure two dampers (19) to disc SUBASSY with four bolts (17) and washers.



(17) Bolts M16×40 : 265 N·m (195 lbf·ft)

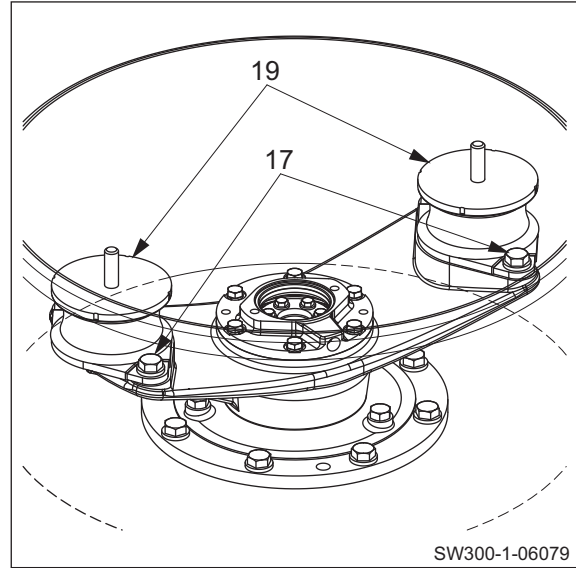

33) Drive two spring pins (22) into sleeve (21).

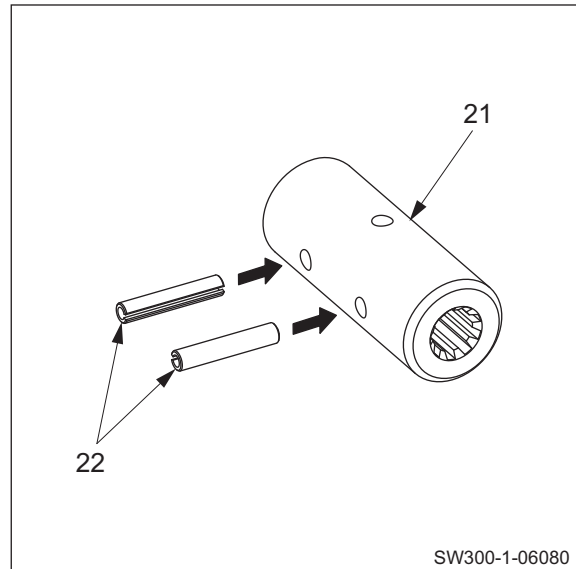

34) Apply molybdenum-based grease to splined portion of sleeve (21).

- Fit sleeve (21) to splined portion on shaft end.

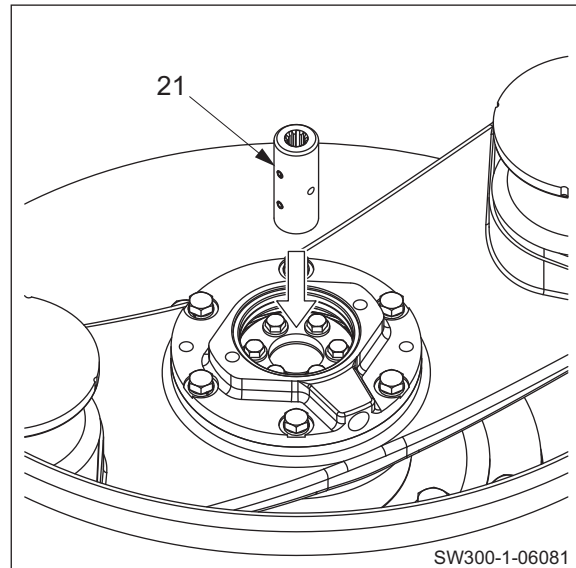

VIBRATORY DRUM - REAR WHEEL

35) Apply grease to O-ring (18).

- Install O-ring to vibrator motor (45).

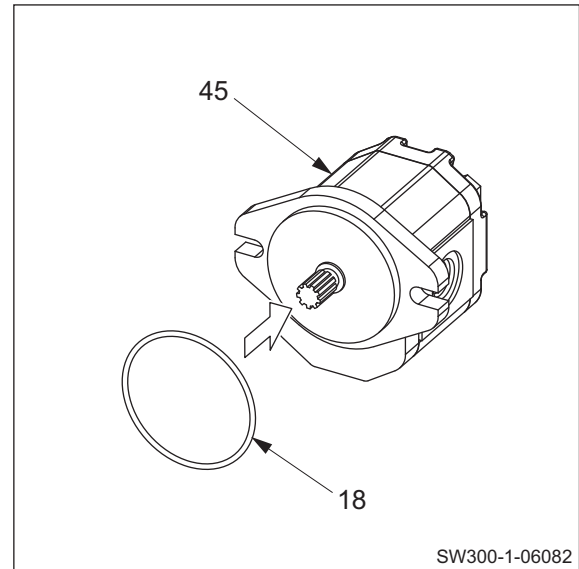

36) Wind seal tape around threaded portion of breather (16).

- Install breather (16) to cover (26).
- Secure vibrator motor (45) to cover (26) with two bolts (43) and washers.

 (45) Vibrator motor : 3 kg (7 lbs.)

 (43) Bolts M10×35 : 49 N·m (36 lbf·ft)

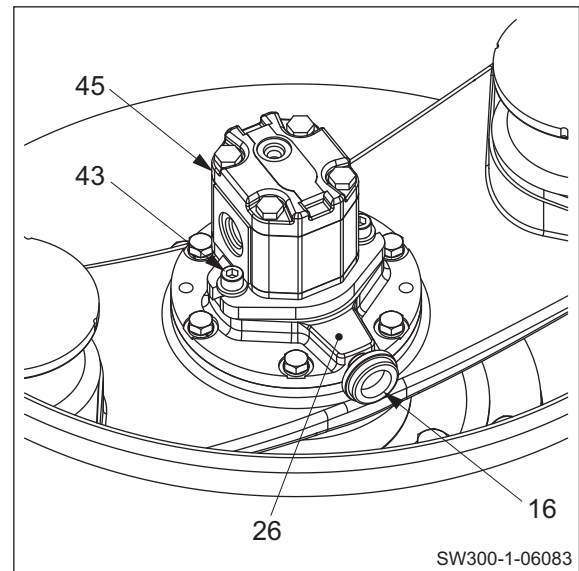

37) Apply grease to O-ring for adapters.

- Install adapters.

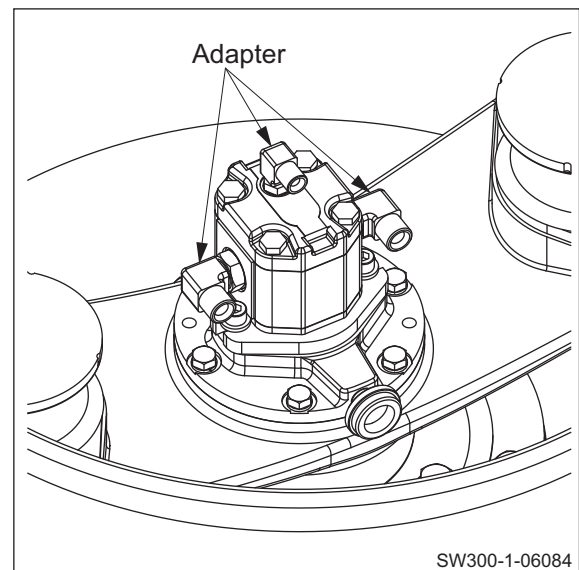

VIBRATORY DRUM • REAR WHEEL

- 38) Lay vibratory drum ASSY with plugs (11-1), (11-2) and (11-3) positioned as shown right.
- Hold with chocks.

 k_g Vibratory drum ASSY

SW300-1 : 515 kg (1,135 lbs.)
SW/TW320-1 : 580 kg (1,279 lbs.)
SW/TW330-1 : 610 kg (1,345 lbs.)

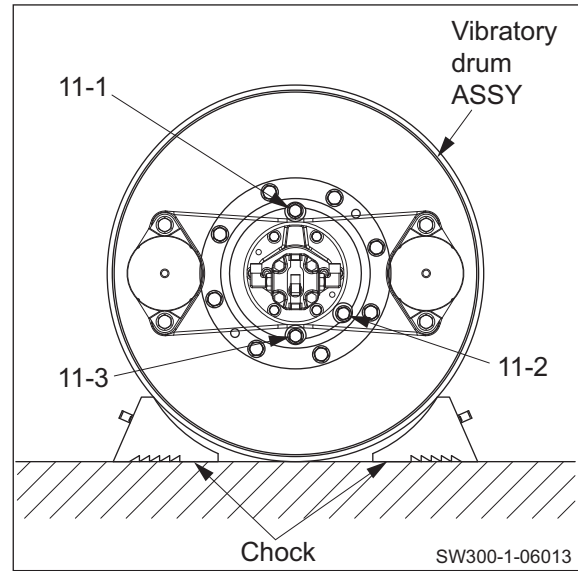

- 39) Remove plugs (11-1) and (11-2).
- Supply gear oil from oil supply port.
 - Check that oil drips from gauge port.

- Quantity of gear oil

SW300-1 : 2.5 L (0.7 gal.)
SW/TW320-1 : 4.0 L (1.1 gal.)
SW/TW330-1 : 4.8 L (1.3 gal.)

- Reinstall plugs (11-1) and (11-2).

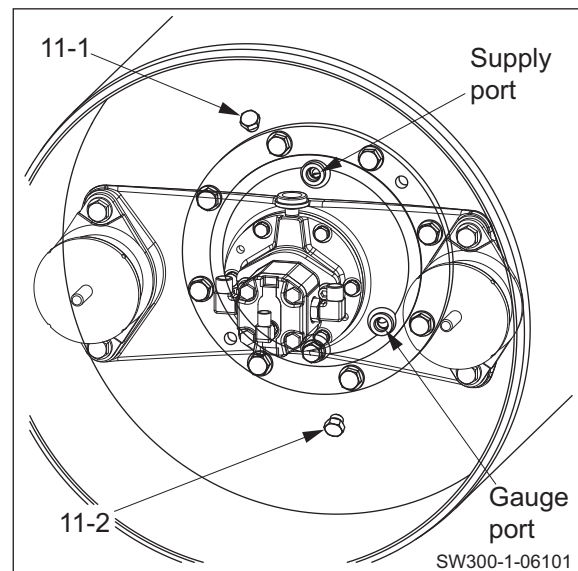

4. REAR AXLE

4-1. Rear Axle ASSY (TW Types)

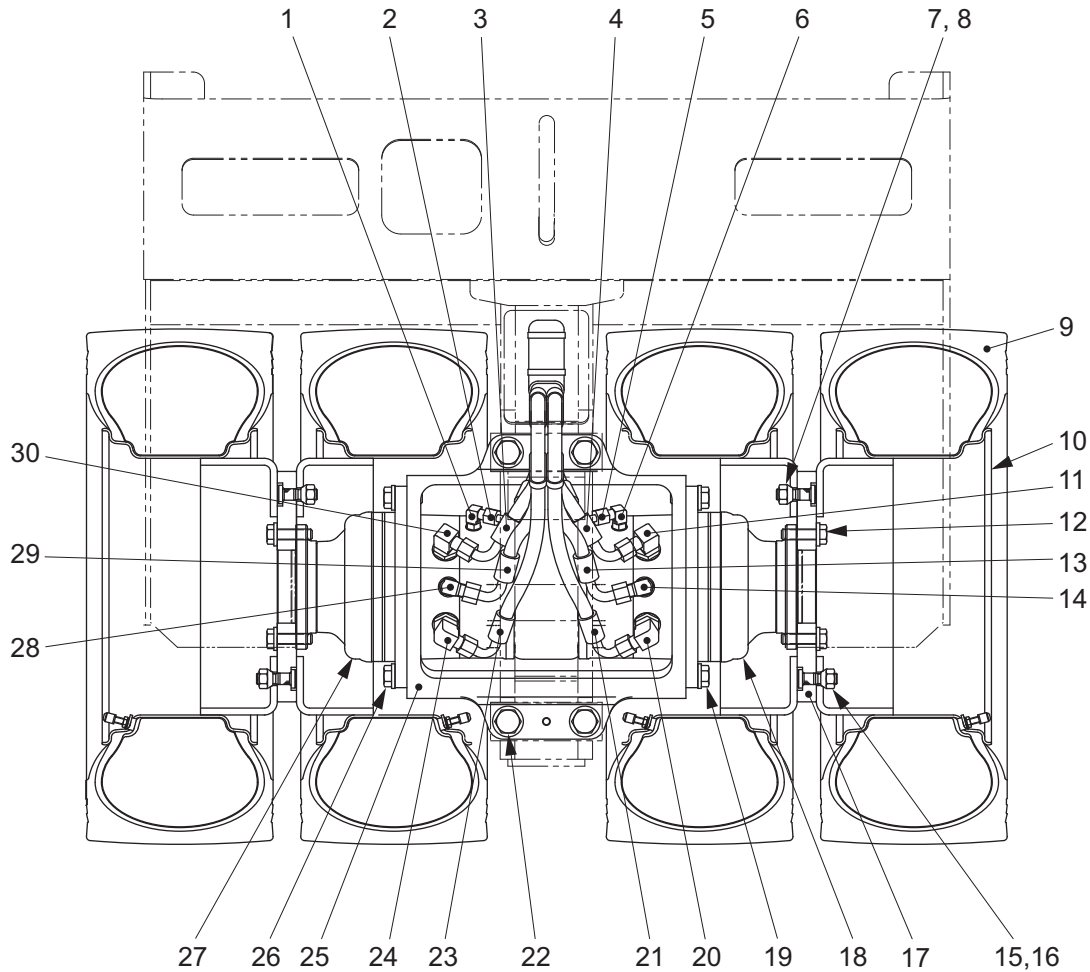

SW300-1-06097

(1) Adapter	(11) Adapter	(21) Hose
(2) Hose	(12) Bolt : M14×50	(22) Bolt : M20×80
(3) Hose	(13) Hose	(23) Hose
(4) Hose	(14) Adapter	(24) Adapter
(5) Hose	(15) Hub bolt : M14×45 P1.5	(25) Bracket
(6) Adapter	(16) Hub nut : M14 P1.5	(26) Bolt : M16×40
(7) Hub bolt : M14×45 P1.5	(17) Disc	(27) Propulsion motor (left)
(8) Hub nut : M14 P1.5	(18) Propulsion motor (right)	(28) Adapter
(9) Tire	(19) Bolt : M16×40	(29) Hose
(10) Disc wheel	(20) Adapter	(30) Adapter



(8) Nut M14 P1.5 : 186 N·m (137 lbf·ft)	(19) Bolt M16×40 : 265 N·m (195 lbf·ft)
(12) Bolt M14×50 : 167 N·m (123 lbf·ft)	(22) Bolt M20×80 : 265 N·m (195 lbf·ft)
(16) Nut M14 P1.5 : 186 N·m (137 lbf·ft)	(26) Bolt M16×40 : 265 N·m (195 lbf·ft)

Specifications

- Tire inflation pressure : 294 kPa (43 psi)

4-2. Removal and Installation of Rear Axle (TW Types)

- Hold vibratory drum with chocks.

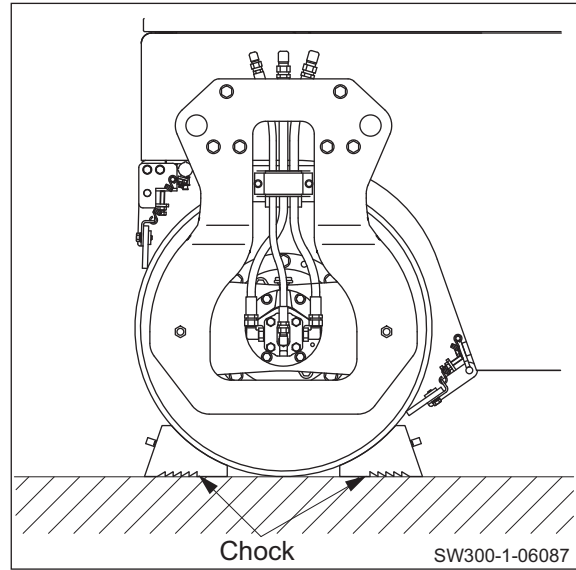

- Lock front and rear frames with lock pin (1).

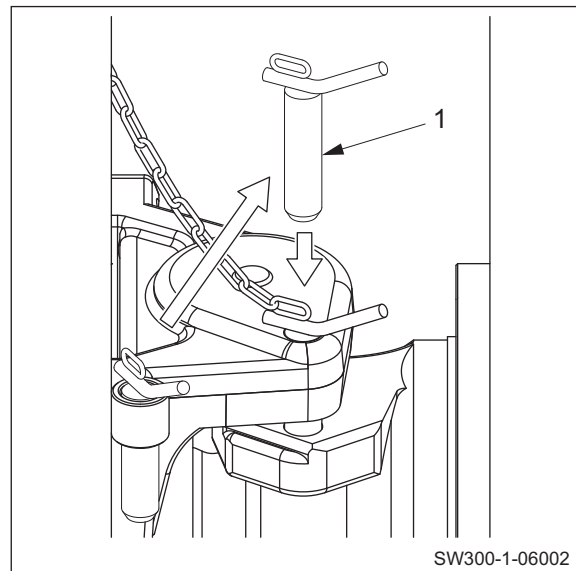

4-2-1. Removal of rear axle

- Lead line numbers shown in illustrations for following rear axle removal and installation procedures are constant with part numbers of rear axle ASSY (TW types) shown on page 6-039.

⚠ DANGER

When lifting the machine body, use an appropriate hoist of sufficient strength. Confirm that the surrounding area is safe, and work in a natural, unstrained posture. Also, to firmly secure the machine body, use a support stand of sufficient strength.

- 1) Supporting rear frame
 - Lift frame with a crane.
 - Place support stands under frame when tires are slightly off ground to support machine body.
 - Flip up scraper blade.

 k_g Rear axle

TW320-1 : 1,430 kg (3,155 lbs.)

TW330-1 : 1,430 kg (3,155 lbs.)

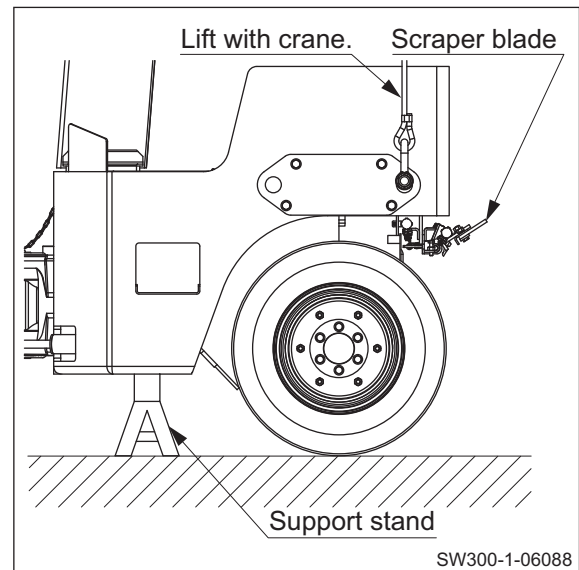

- 2) Remove bolts (12).

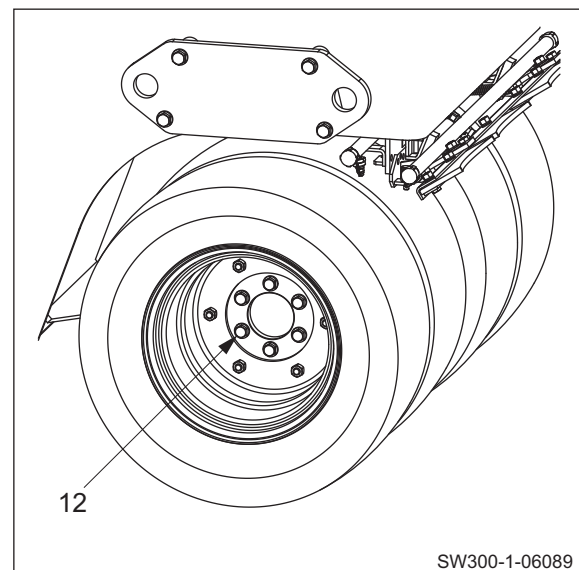

VIBRATORY DRUM - REAR WHEEL

3) Remove wheel SUBASSY with forklift.

 Wheel SUBASSY : 105 kg (231 lbs.)

- Wheel SUBASSY of right side is also removed in the same procedure.

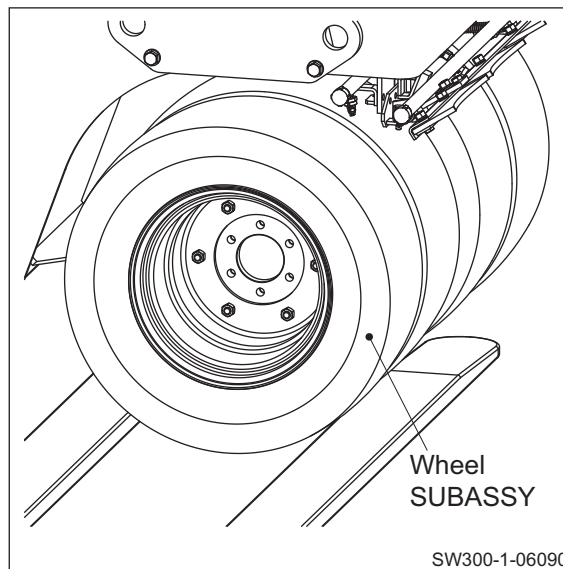

WARNING

The hydraulic oil in the machine is hot and compressed immediately after the machine is stopped. Disconnecting the hydraulic hoses in this condition can cause burns. Wait for the hydraulic oil to cool down before starting the work.

4) Disconnecting piping

- Disconnect hydraulic hoses (13), (21), (23) and (29) connecting to rear propulsion motor.

(NOTICE)

- Plug both ends of disconnected hoses or implement other actions to prevent entry of foreign matter.

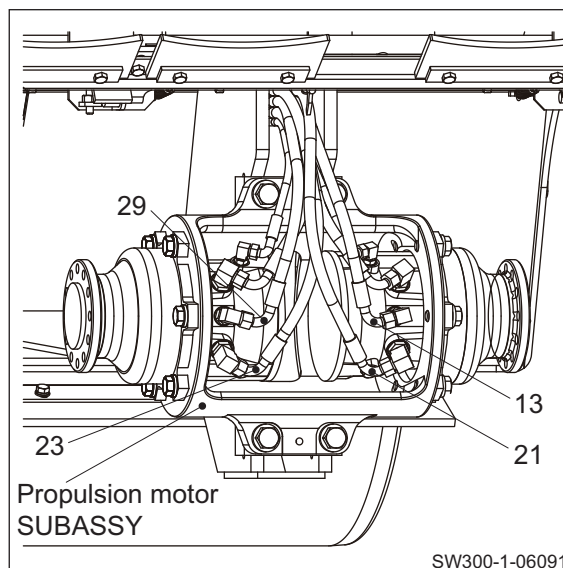

VIBRATORY DRUM - REAR WHEEL

- Disconnect hydraulic hoses (2), (3), (4) and (5) connecting to rear propulsion motor.

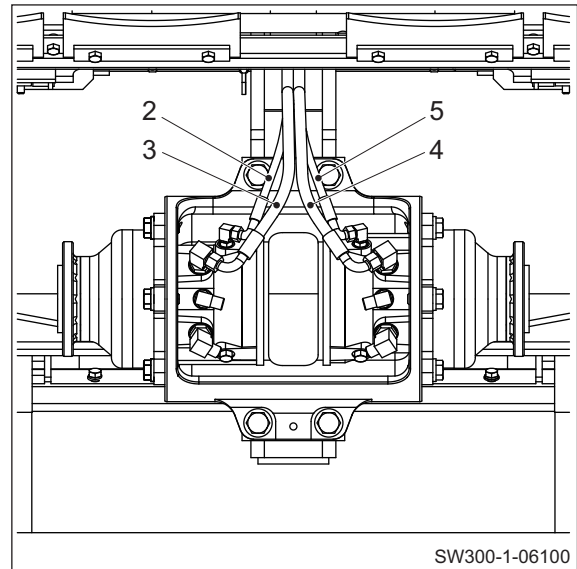

- 5) Hold up propulsion motor SUBASSY with forklift.
 - Remove bolts (22).
 - Remove propulsion motor SUBASSY.

 125 kg Propulsion motor SUBASSY : 125 kg (276 lbs.)

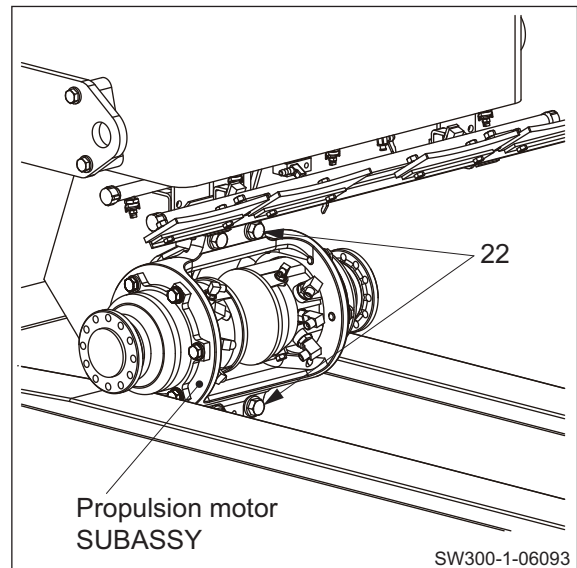

4-2-2. Installation of rear axle

- 1) Install rear axle in reverse order in which it was removed.
 - Tightening torque for bolts where particular care is required when installing rear axle.

 (12) Bolt M14x50 : 167 N·m (123 lbf·ft)
(22) Bolt M20x80 : 265 N·m (195 lbf·ft)

- 2) Upon installing rear axle, pay particular attention to items mentioned below.
 - Fill hydraulic oil tank to specified level to make up for any oil leakage.
 - Start engine and circulate oil through piping. Then check oil level again, ensuring that oil is at specified level.

(NOTICE)

- **If the engine is run at high speed or the cylinder is operated to full stroke when the engine is started for the first time after the work is completed, the piston packing or other items may be damaged by air entering into the cylinder.**

BRAKE

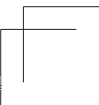
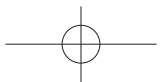
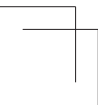
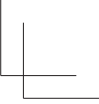
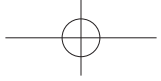

1. BRAKE PEDAL

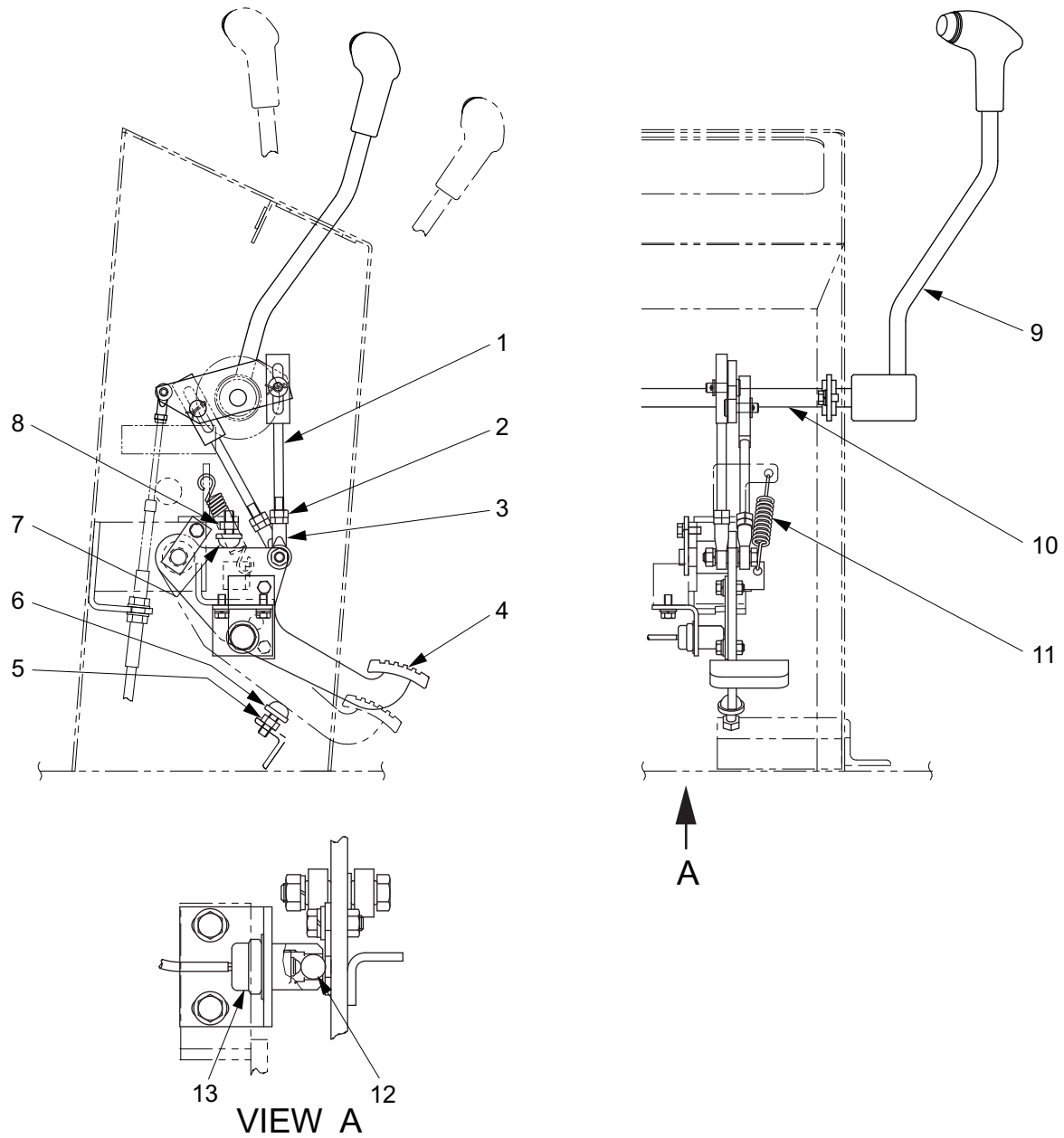

0445-51803-0-10686-0

- | | | | | |
|----------------------|-----------------|--|-------|--------|
| (1) Rod | | (8) Nut | : M10 | P=1.25 |
| (2) Nut | : M10 | (9) F-R lever | | |
| (3) Rod end | | (10) Shaft | | |
| (4) Brake pedal | | (11) Return spring | | |
| (5) Nut | : M10 | (12) Ball (Apply lithium-based grease) | | |
| (6) Bolt with rubber | : M10×25 P=1.25 | (13) Foot brake switch | | |
| (7) Bolt with rubber | : M10×25 P=1.25 | | | |

2. BRAKE SYSTEM

2-1. SW types

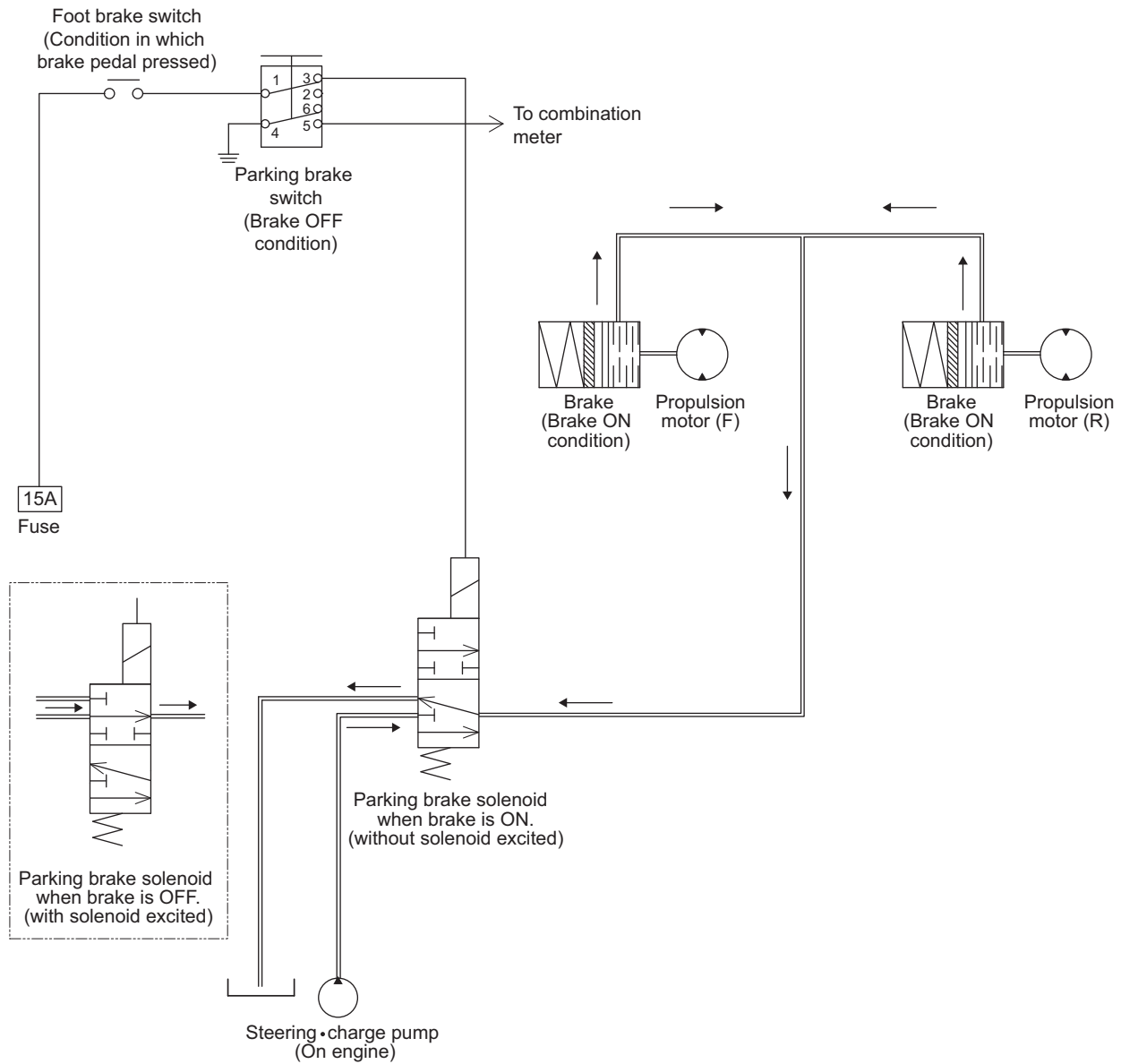

• The arrow (→) symbol shows the direction of the hydraulic oil flow.

SW300-1-07002

2-2. TW types

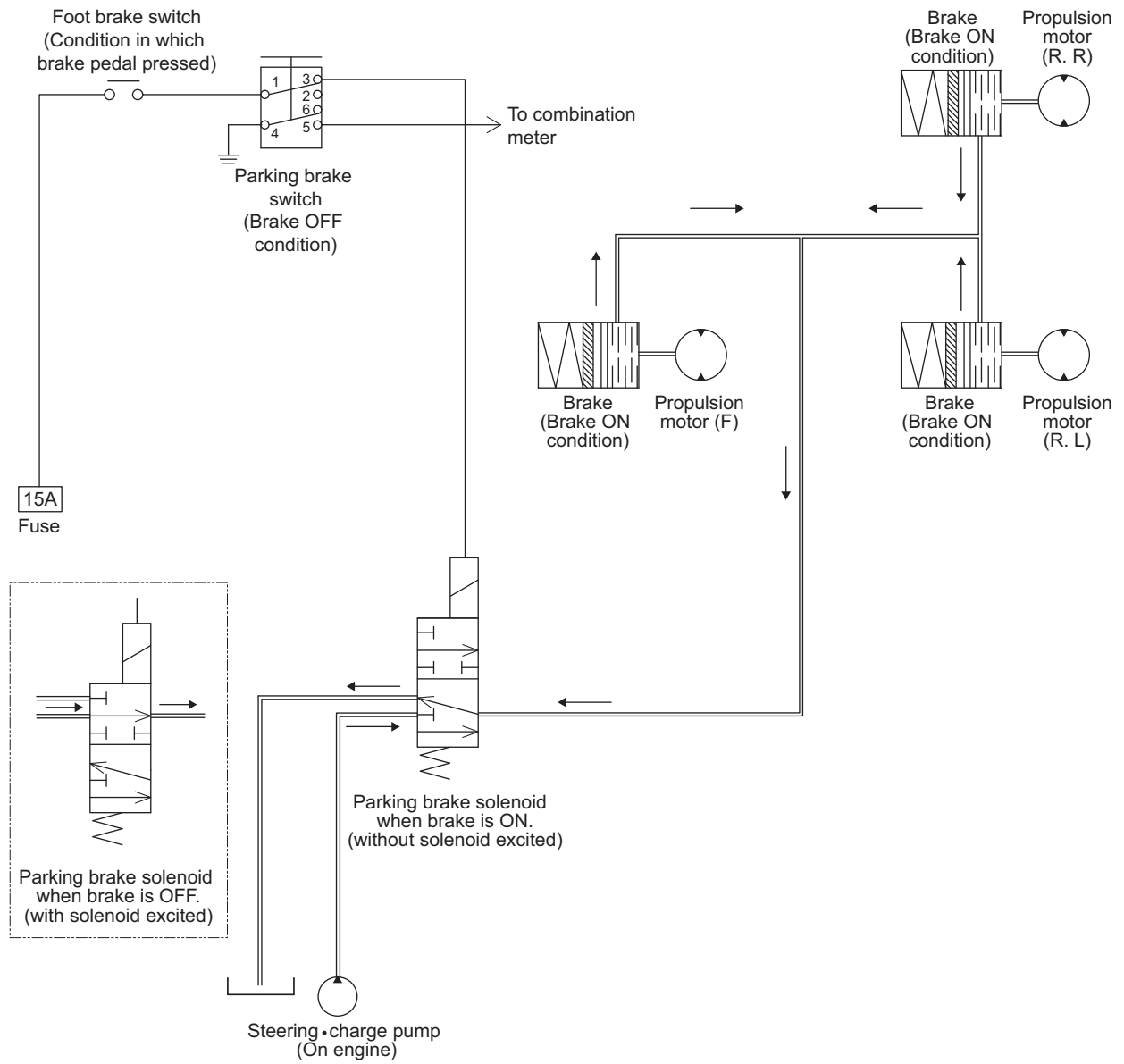

• The arrow (→) symbol shows the direction of the hydraulic oil flow.

TW320-1-07001

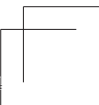
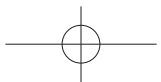
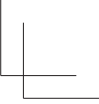
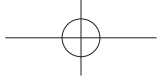

SPRAY SYSTEMS

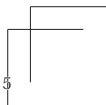
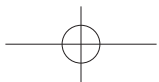
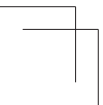
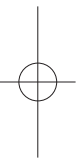
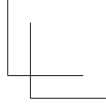
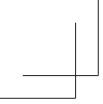

1. WATER SPRAY SYSTEM

1-1. Water Spray Piping (SW types)

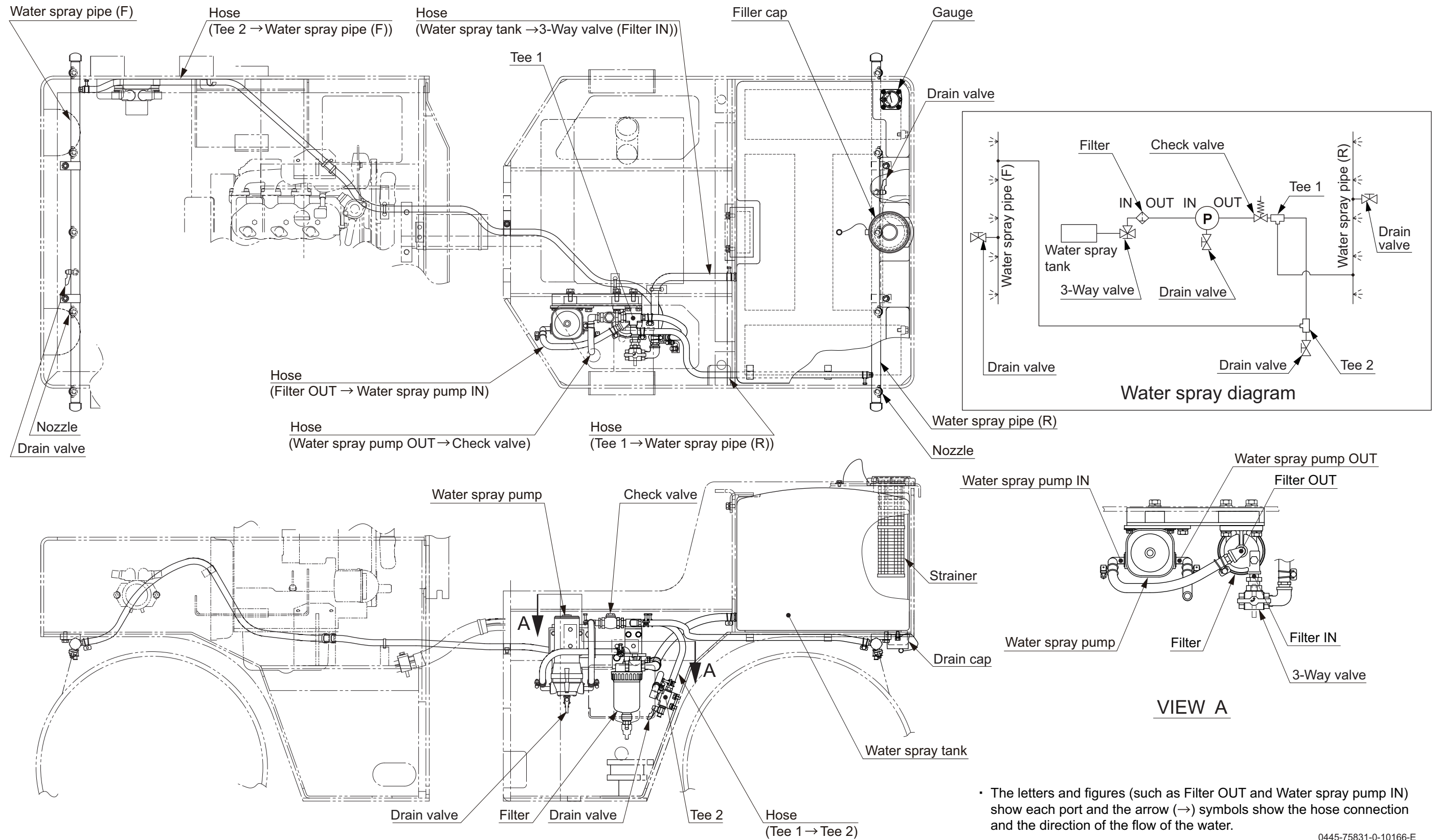

• The letters and figures (such as Filter OUT and Water spray pump IN) show each port and the arrow (→) symbols show the hose connection and the direction of the flow of the water.

0445-75831-0-10166-E

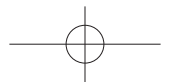
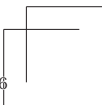
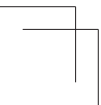
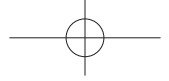
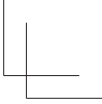
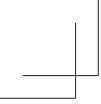

1-2. Water Spray Piping (TW types)

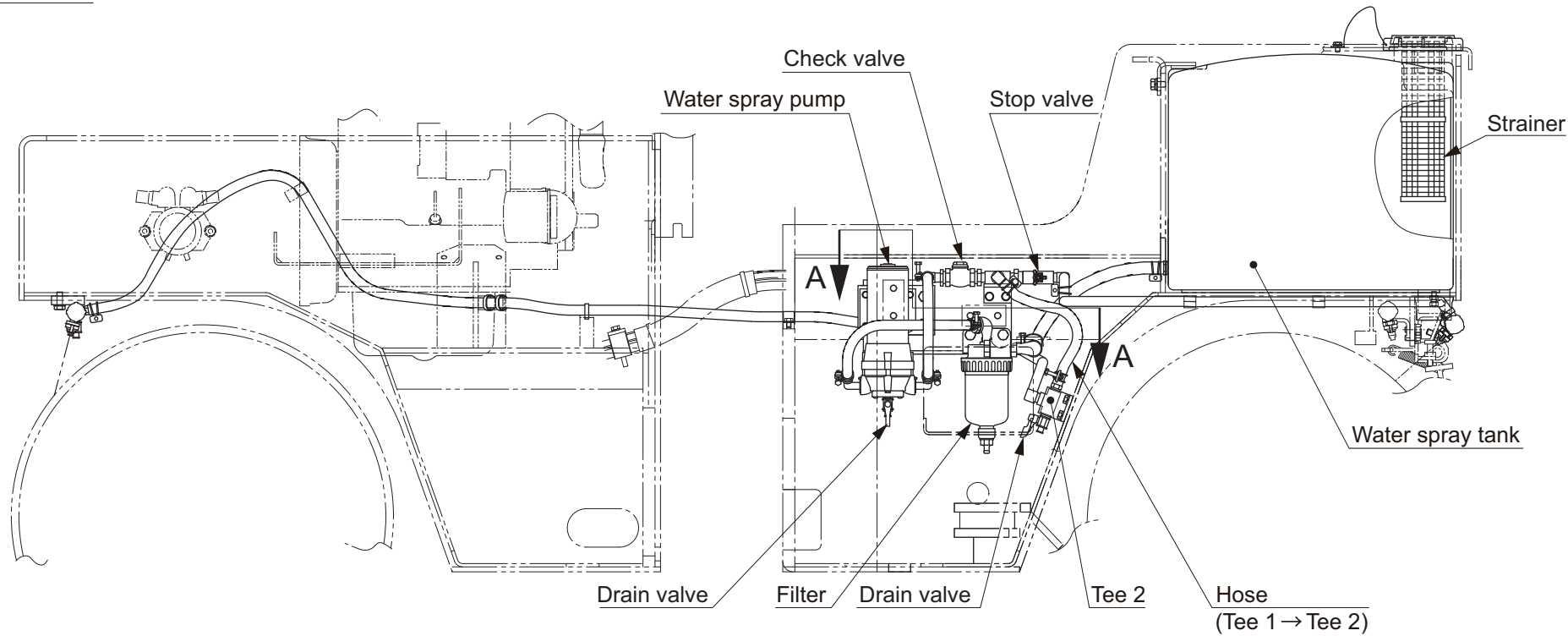
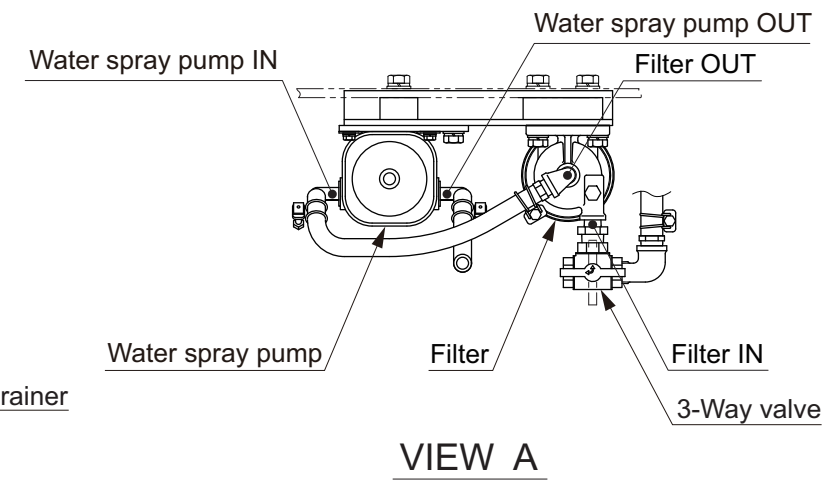
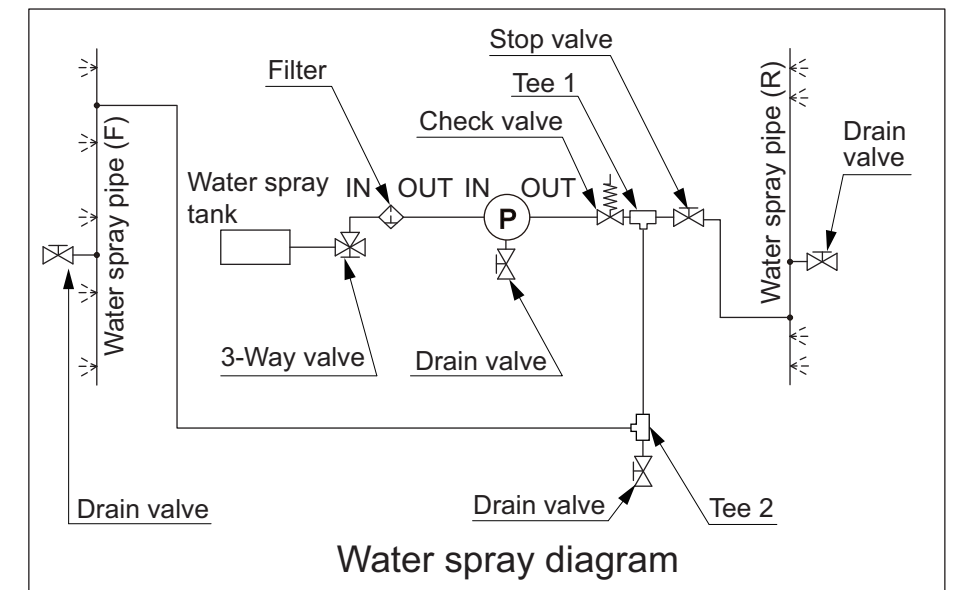
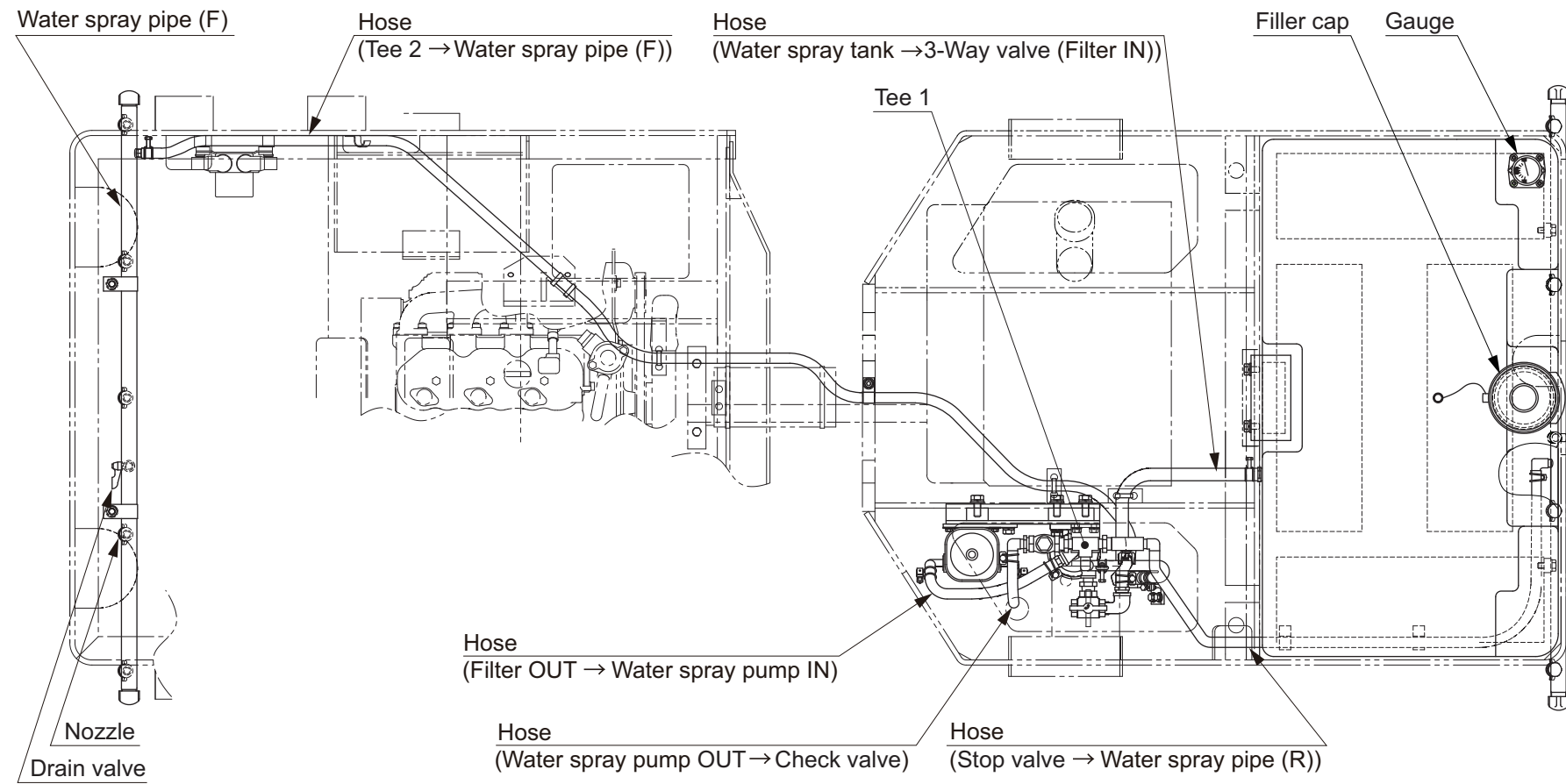

• The letters and figures (such as Filter OUT and Water spray pump IN) show each port and the arrow (→) symbols show the hose connection and the direction of the flow of the water.

0425-75801-0-10018-0

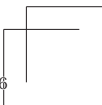
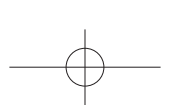
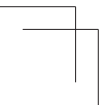
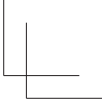
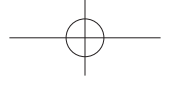
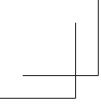

2. LIQUID SPRAY SYSTEM (TW TYPES)

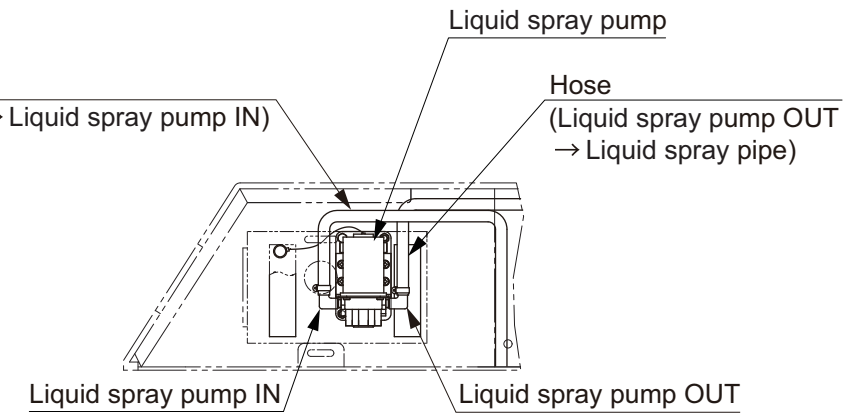
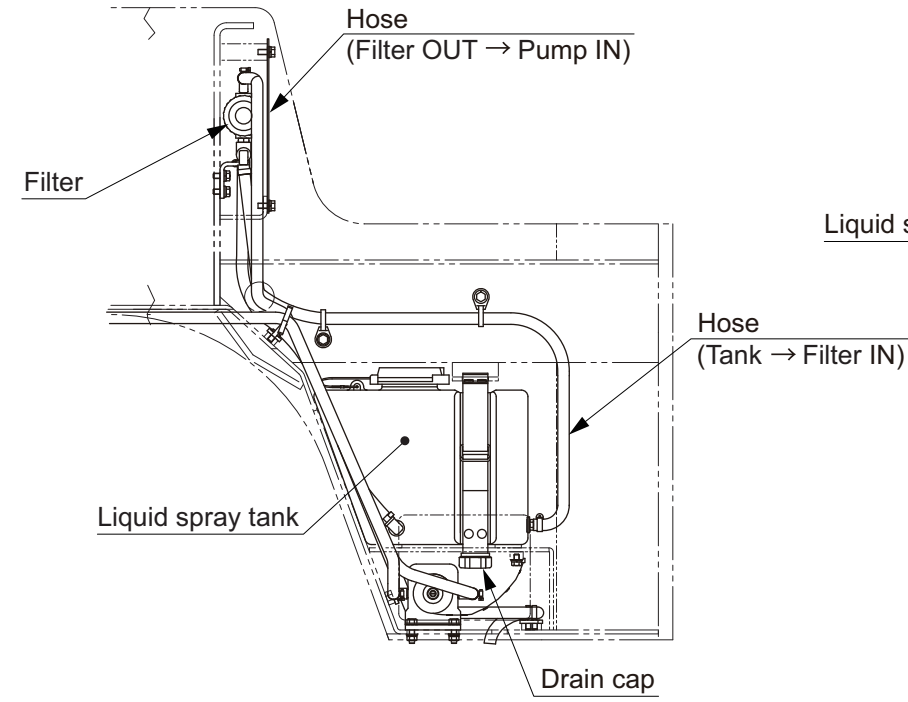
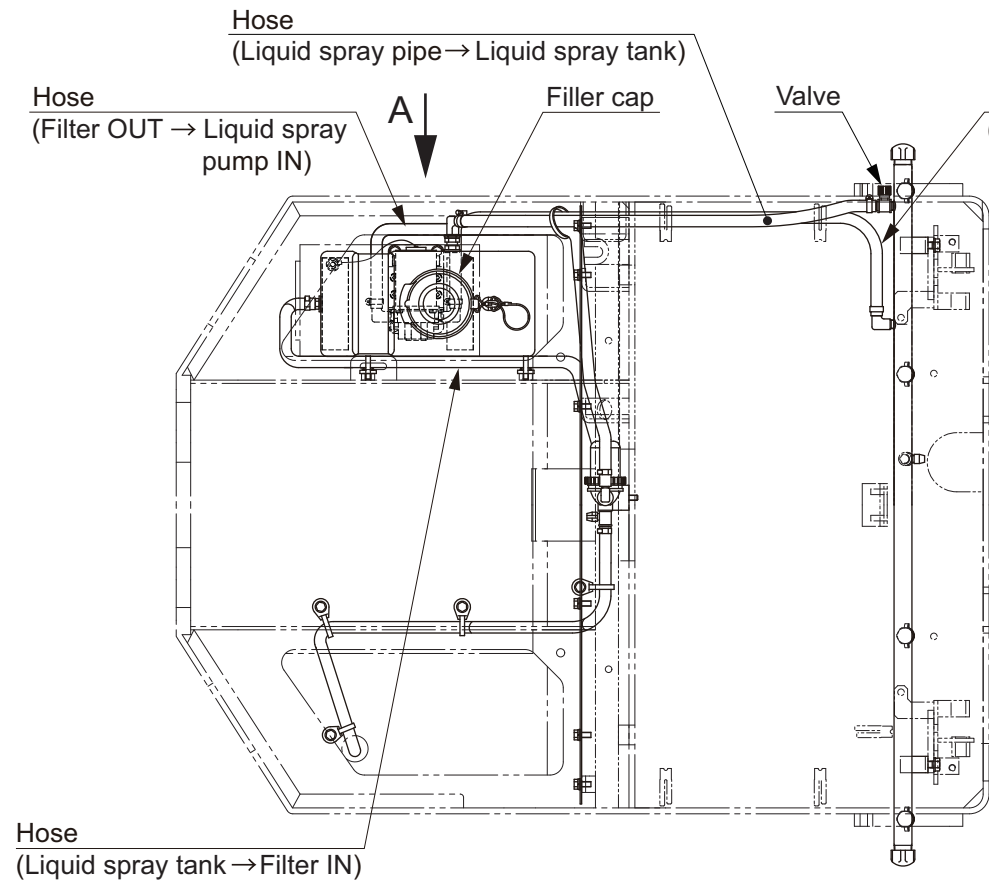

SECTION B-B

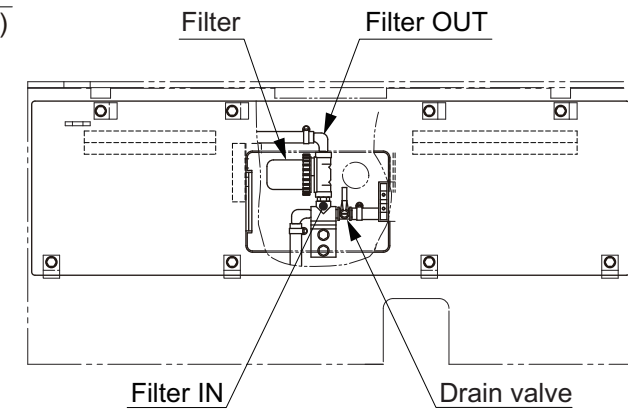

VIEW C

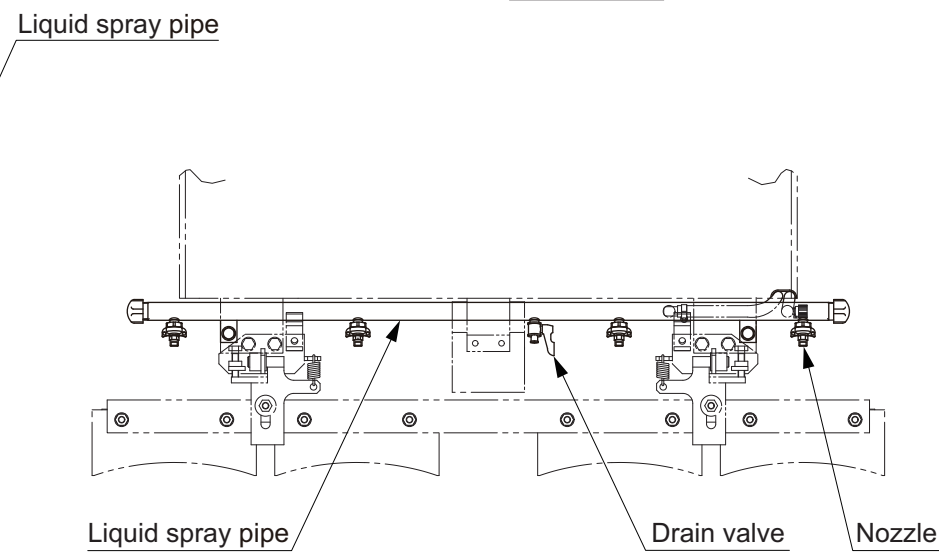
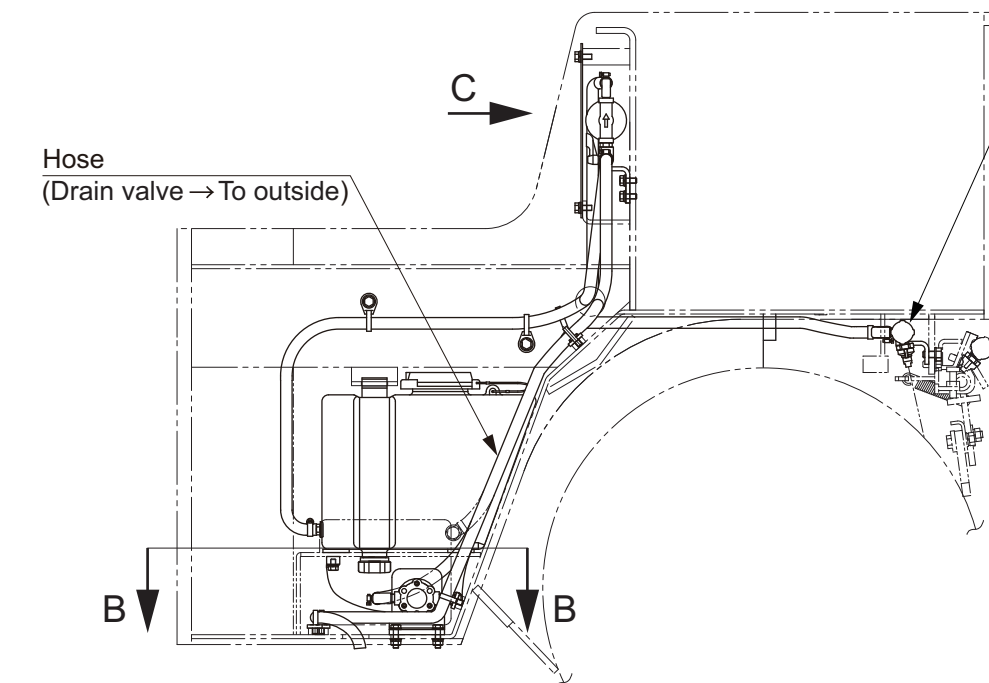

The letters and figures (such as Filter OUT and Liquid spray pump IN) show each port and the arrow (→) symbols show the hose connection and the direction of the flow of the water.

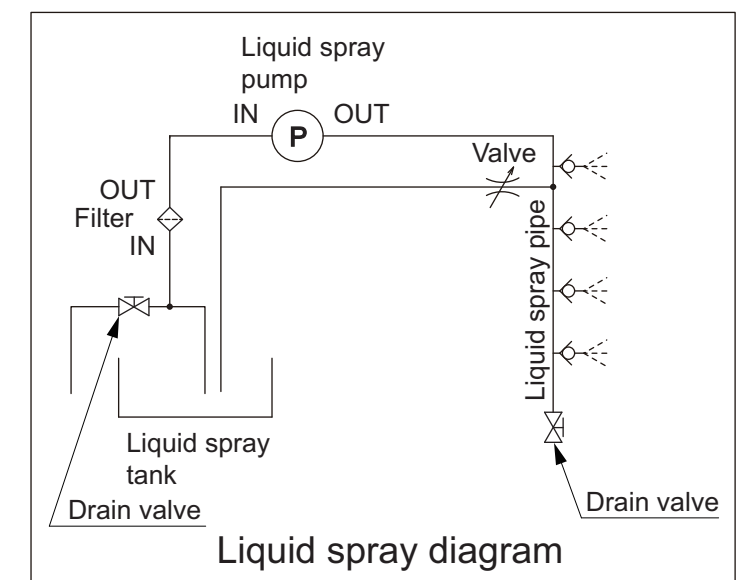

0425-75804-0-10021-A

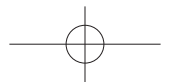
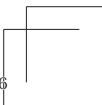
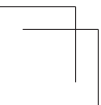
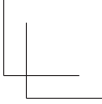
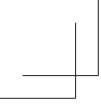

INSPECTION AND ADJUSTMENT

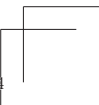
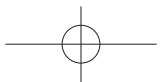
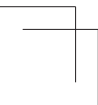
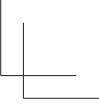
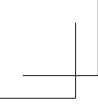

1. INSPECTION AND ADJUSTMENT

1-1. Safety Precautions for Inspection and Adjustment

⚠ WARNING

Unexpected machine movement may cause a serious accident. When inspecting the machine while the engine is running, always follow the instructions below.

- Park the machine on level, flat ground.
- Apply the parking brake.
- Set chocks in front and behind each drum or tire.
- Make sure that service personnel are given the appropriate information at the appropriate time.
- Make sure that no one can enter any hazardous area.

⚠ CAUTION

Do not work on the hydraulic system while the engine is running and the system is hot and under pressure. Do not disconnect hydraulic hoses or fittings until the system has cooled and pressure has been properly relieved.

Before removing any plugs from the pressure measurement ports, always release any residual pressure from the piping and open the cap of the fluid tank to release and pressure.

⚠ WARNING

Inadvertent starting the engine may cause a serious accident.

When inspecting the engine, make sure to exchange the appropriate cues and hand signal with the person at the operator station to avoid any accidents.

⚠ CAUTION

Before inspecting inside of the engine compartment, always stop the engine.

Contact with the fan, V-belt or exhaust system parts while the engine is running may cause serious injury.

1-2. Preparation for Inspection and Adjustment

- Prepare the necessary measuring instruments. In addition, particularly when measuring pressure values, make sure to prepare the appropriate hoses, adapters and a plug removal tool for the pressure reading port.
- Make sure that the instruments to be used operate normally.
When handling the instruments, exercise sufficient caution not to drop or apply any impact to them. Doing so may adversely affect the calibration. Another important point is to inspect the instruments regularly. An instrument that does not start from the appropriate zero point may give an inaccurate reading.

1-3. Precautions for Inspection and Adjustment

- When performing inspections and adjustments, pay special attention to safety.
- For each inspection, always take three measurements for each measurement point. If the measurements significantly differ, the measurement method may be incorrect. In such a case, take measurements once again and calculate their average.

1-4. Warm-up

- Machinery will not exhibit their true performance under the cold condition. Before taking measurements, always warm up the engine and make sure that the fluid and engine coolant are warmed to their specified normal operating temperatures.

1-5. Inspection and Adjustment of Engine Related Items

- Refer to shop manual of engine manufacturer for inspection and adjustment of engine itself.

2. MEASUREMENT AND INSPECTION OF PROPULSION CIRCUIT PRESSURE

2-1. Measurement

⚠ WARNING

Confirm that the parking brake works properly before measurement.

- Oil temperature during measurement : $50 \pm 5^{\circ}\text{C}$ ($122 \pm 41^{\circ}\text{F}$)
- ① Remove plugs from high pressure gauge port (1-2) and (1-5) of propulsion pump. Attach pressure gauge with adapter (h) .
 - Adapter (h) : 9/16-18UNF
 - High pressure gauge port (Reverse) : (1-2)
 - High pressure gauge port (Forward) : (1-5)
 - Pressure gauge : 0 to 50 MPa (0 to 7,250 psi)
- ② Start the engine and set throttle lever to "Full".
- ③ Establish a condition in which machine propulsion load becomes maximum. (Pressure does not build up unless propulsion load is applied.)
- ④ With propulsion load at maximum, slowly move F-R lever to the side to be measured.
 - Then, read pressure indicated by pressure gauge.
- ⑤ After measuring, promptly return F-R lever to "N".

★ **Maximum circuit pressure**
(high pressure relief valve setting)
: $34.5 \pm 1.0 \text{ MPa}$ ($5,003 \pm 145 \text{ psi}$)

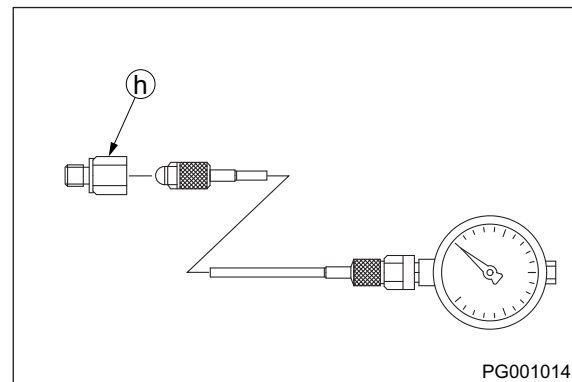
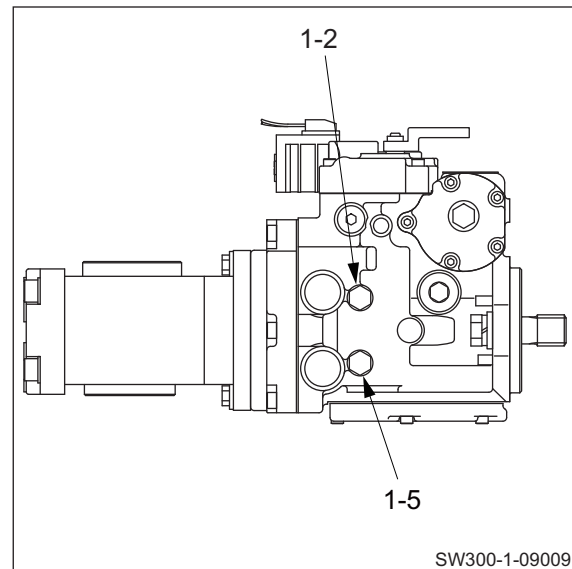

- The numbers "1-2" and "1-5" appearing in above illustrations are consistent with lead line numbers shown in illustration of propulsion pump in "2-2. Hydraulic Component Specifications" (page 4-010).

2-2. Inspection

- If measurement results indicate the pressure deviating from maximum circuit pressure range, make an inspection in accordance with procedure described below.
- ① Remove plug and valve from high pressure relief and bypass valves (1-11) or (1-12) of propulsion pump.
 - *High pressure relief and bypass valves (Reverse) : (1-11)
 - *High pressure relief and bypass valves (Forward) : (1-12)
 - ② Check removed high pressure relief and bypass valves for trapped dirt and other abnormalities.
 - ③ If trapped dirt is present, disassemble and clean high pressure relief and bypass valves.
 - ④ If pressure still deviates from maximum circuit pressure range after valve is disassembled and cleaned, replace high pressure relief and bypass valves.
 - ⑤ After inspection, measure pressure again and check that pressure reaches maximum circuit pressure range.



Bypass valve : 70 N·m (52 lbf·ft)

(NOTICE)

- **Carefully disassemble and reassemble after taking steps to prevent foreign material from getting in.**

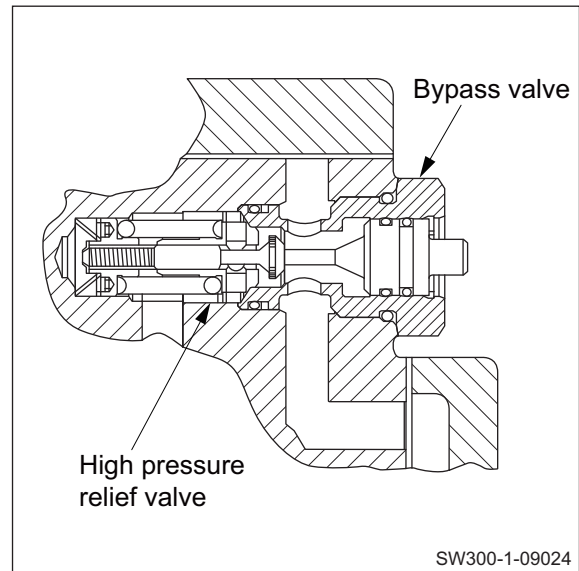
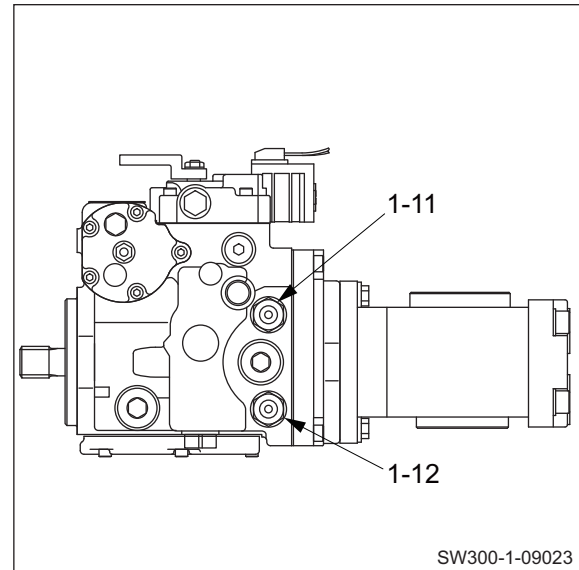

* : High pressure relief and bypass valves = S.C.R. (System Check Relief) valve for charge check and high pressure relief and bypass valve.

- The numbers “1-11” and “1-12” appearing in above illustrations are consistent with lead line numbers shown in illustration of propulsion pump in “2-2. Hydraulic Component Specifications” (page 4-010).

3. MEASUREMENT AND ADJUSTMENT OF PROPULSION CHARGE CIRCUIT PRESSURE

- Since oil in charge circuit is supplied from steering circuit, confirm that steering operation is normal before measurement.
- Ensure that neutral positions of F-R lever and hydraulic pump are aligned.

3-1. Measurement

- Oil temperature during measurement : $50 \pm 5^{\circ}\text{C}$ ($122 \pm 41^{\circ}\text{F}$)
- ① Remove plugs from servo pressure gauge port (1-3) and (1-7) of propulsion pump. Attach pressure gauge with adapter (h) .
 - Adapter (h) : 9/16-18UNF
 - Pressure gauge : 0 to 5 MPa (0 to 725 psi)
- ② Apply parking brake by pressing parking brake switch button.
- ③ Start the engine and set throttle lever to "Full".
- ④ Check that F-R lever is in "N".
 - Then, read pressure indicated by pressure gauge.

★ **Standard charge relief valve setting**

: $1.9 \pm 0.07 \text{ MPa}$ ($276 \pm 10.2 \text{ psi}$)

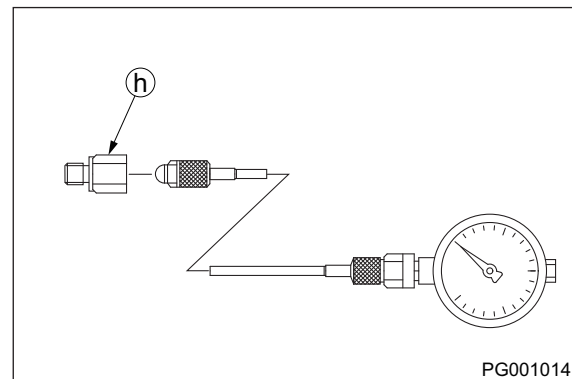
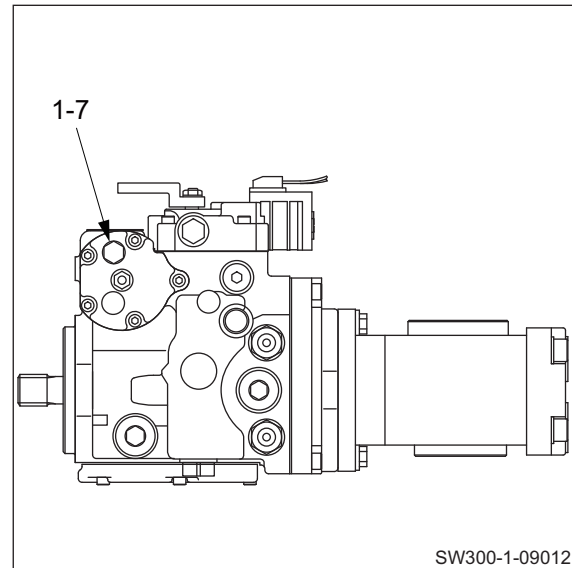
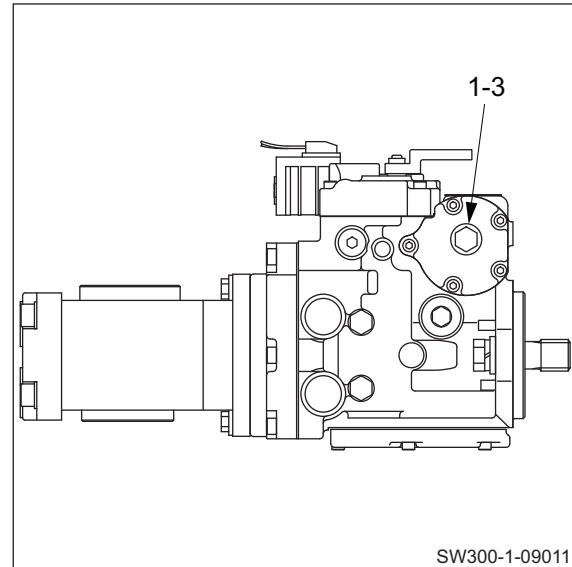

- The numbers "1-3" and "1-7" appearing in above illustrations are consistent with lead line numbers shown in illustration of propulsion pump in "2-2. Hydraulic Component Specifications" (page 4-010).

3-2. Adjustment

- If measurement results indicate the pressure deviating from standard charge relief pressure setting range, make an adjustment in accordance with procedure described below.

- ① Check nut (1) of charge relief valve (1-13) for evidence of having loosened.
- ② If there is evidence of nut having loosened, adjust charge relief valve so that pressure becomes within standard charge relief valve pressure setting range while watching pressure gauge.
- To adjust pressure, loosen nut and turn adjustment screw (2).

Adjustment screw turned clockwise

: Pressure rise

Adjustment screw turned counterclockwise

: Pressure drop

Pressure change rate : 0.19 MPa/turn (27.6 psi/turn)

- ③ If there is no evidence of nut having loosened, remove charge relief valve.
- ④ Check removed charge relief valve for trapped dirt and scratches on its seat.
- ⑤ If trapped dirt is present, disassemble and clean charge relief valve.
- ⑥ If a scratch is found on seat, replace charge relief valve.
- ⑦ After adjustment, measure pressure again and check that pressure reaches standard charge relief valve setting range.



(1) Nut : 24 N·m (18 lbf·ft)

(NOTICE)

- **Carefully disassemble and reassemble after taking steps to prevent foreign material from getting in.**

- The number “1-13” appearing in above illustrations is consistent with lead line numbers shown in illustration of propulsion pump in “2-2. Hydraulic Component Specifications” (page 4-010).

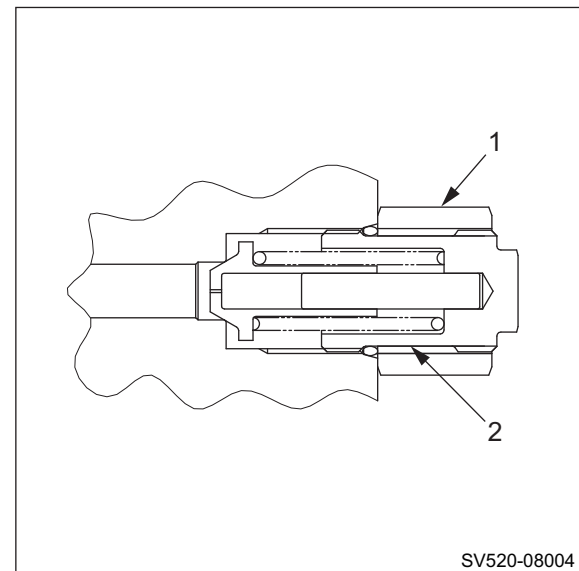
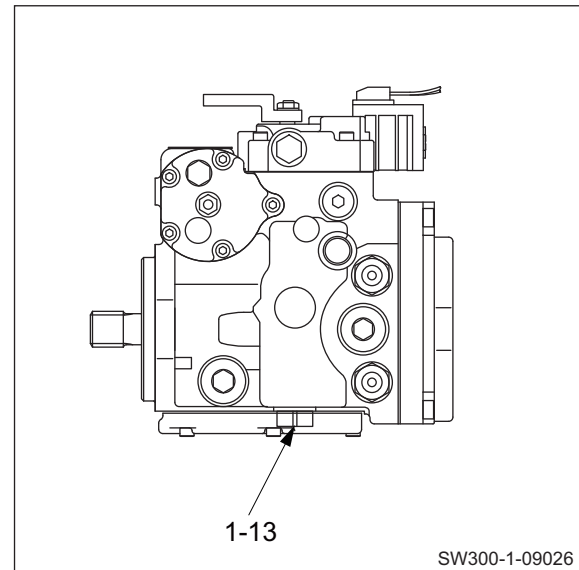

4. MEASUREMENT OF PARKING BRAKE RELEASE PRESSURE

- Since parking brake release pressure is supplied from steering circuit, confirm that steering operation is normal before measurement.

4-1. Measurement

4-1-1. SW types: front and rear, TW types: front

- Oil temperature during measurement : $50 \pm 5^{\circ}\text{C}$ ($122 \pm 41^{\circ}\text{F}$)
- ① Disconnect hose (1) from propulsion motor. Attach pressure gauge through adapter (m) .
 - Adapter (m) : G1/4
 - Pressure gauge: 0 to 5 MPa (0 to 725 psi)
- ② Confirm that F-R lever is in "N".
- ③ Apply parking brake by pressing parking brake switch button.
- ④ Start the engine and set throttle lever to "Full".
- ⑤ Release parking brake by pressing parking brake switch button.
 - Then, read brake release pressure indicated by pressure gauge.

★ Brake release pressure

: More than 1.5 MPa (218 psi)

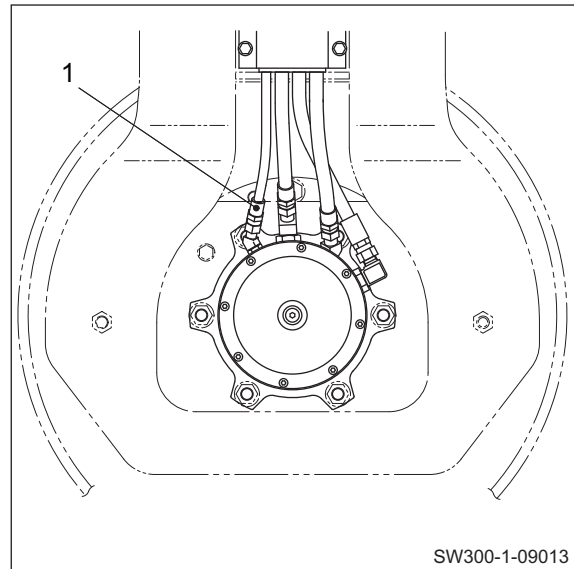

SW300-1-09013

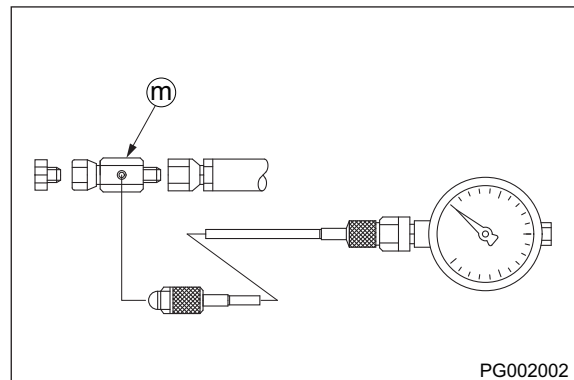

PG002002

4-1-2. TW types: rear

- Oil temperature during measurement : $50 \pm 5^{\circ}\text{C}$ ($122 \pm 41^{\circ}\text{F}$)
 - ① Disconnect hose (2) and (3) from propulsion motor. Attach pressure gauge through adapter (m) .
 - Adapter (m) : G1/4
 - Pressure gauge : 0 to 5 MPa (0 to 725 psi)
 - ② Confirm that F-R lever is in "N".
 - ③ Apply parking brake by pressing parking brake switch button.
 - ④ Start the engine and set throttle lever to "Full".
 - ⑤ Release parking brake by pressing parking brake switch button.
 - Then, read brake release pressure indicated by pressure gauge.

★ Brake release pressure

: More than 1.5 MPa (218 psi)

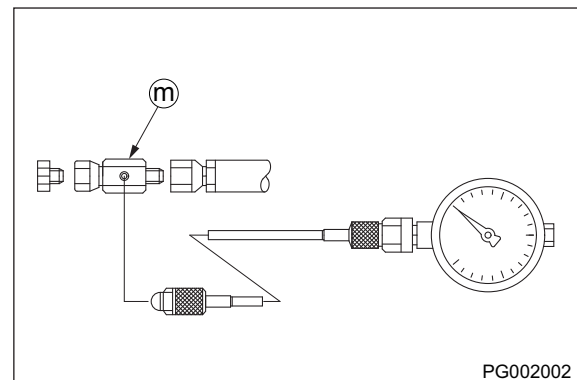
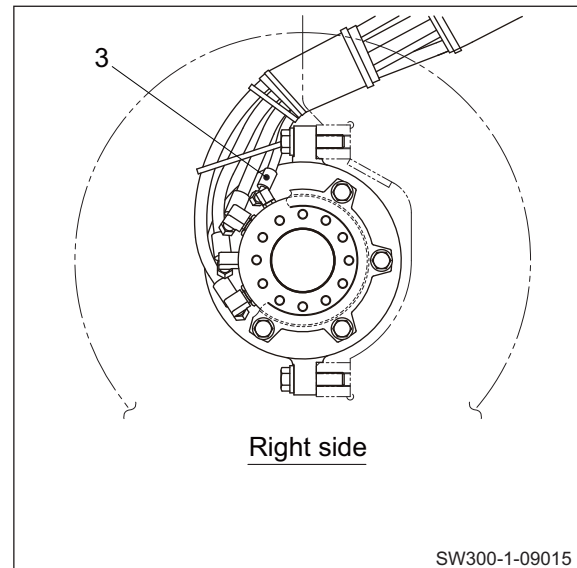
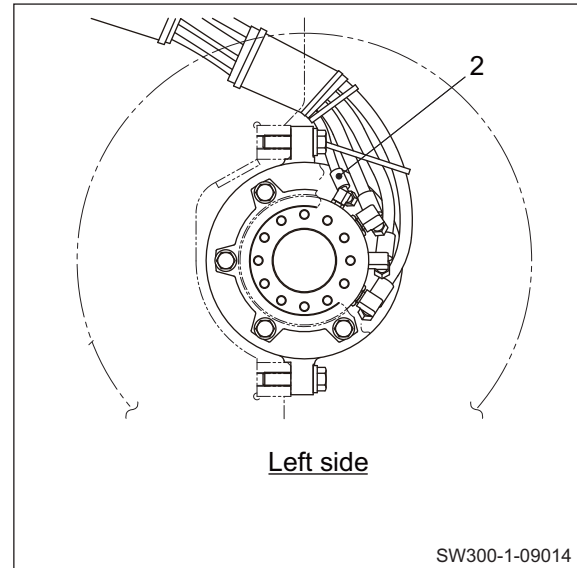

5. MEASUREMENT OF VIBRATOR CIRCUIT PRESSURE

5-1. Measurement (SW types: front and rear, TW types: front)

⚠ CAUTION

Take care not to operate the vibratory drum for a longer period of time than necessary with the machine stationary. Otherwise, the vibrator bearing could be seized.

- Oil temperature during measurement : $50 \pm 5^{\circ}\text{C}$ ($122 \pm 41^{\circ}\text{F}$)
- ① Disconnect hose (1) from vibrator motor. Attach pressure gauge through adapter (P) .
 - Adapter (P) : G1/2
 - Pressure gauge : 0 to 24.5 MPa (0 to 3,552.5 psi)
- ② Apply parking brake by pressing parking brake switch button.
- ③ Start the engine and set throttle lever to "Full".
- ④ Set vibration mode select switch to " ".
- ⑤ Keep pressing F-R lever vibration switch (ON).
 - Then, read pressure indicated by pressure gauge.
- ⑥ Release F-R lever vibration switch (OFF) as soon as measurement is finished.

★ **Maximum circuit pressure**
(relief valve pressure setting)

: $12.7 \pm 0.5 \text{ MPa}$ ($1,842 \pm 72.5 \text{ psi}$)

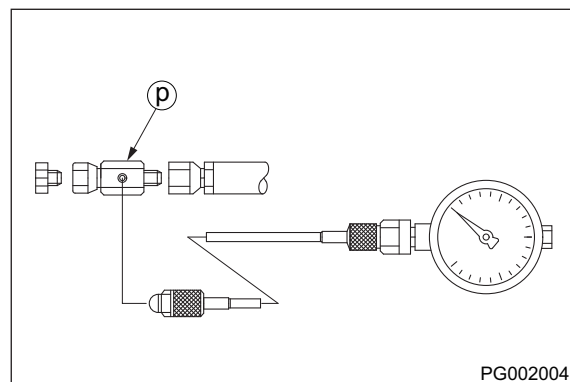
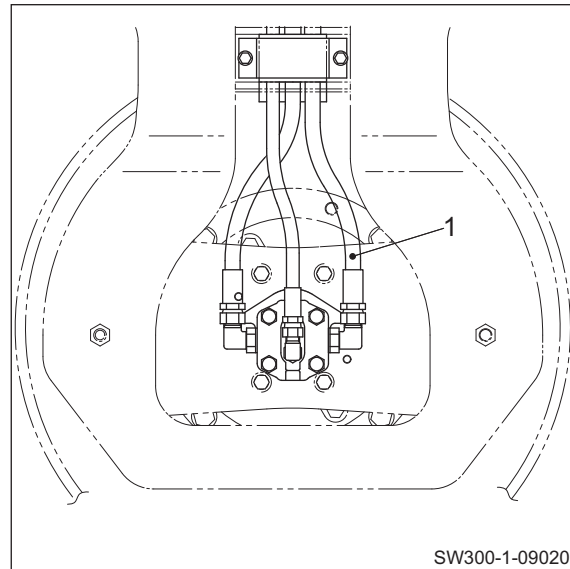

6. MEASUREMENT AND INSPECTION OF STEERING CIRCUIT PRESSURE

6-1. Measurement

⚠ WARNING

Make sure that there is no person around the articulated portion of the machine before operating the steering wheel.

- Oil temperature during measurement : $50 \pm 5^{\circ}\text{C}$ ($122 \pm 41^{\circ}\text{F}$)

① Disconnect hose (1) from steering charge pump.

Attach pressure gauge through adapter (n) .

- Adapter (n) : G3/8
- Pressure gauge : 0 to 25 MPa (0 to 3,625 psi)

② Confirm that F-R lever is in "N" properly.

③ Start the engine and set throttle lever to "Full".

④ Turn steering wheel to operate relief valve.

- Then, read pressure indicated by pressure gauge.

★ Standard maximum circuit pressure

(orbitroll relief pressure + charge relief pressure)

: 14.9 ± 1.0 MPa ($2,161 \pm 145$ psi)

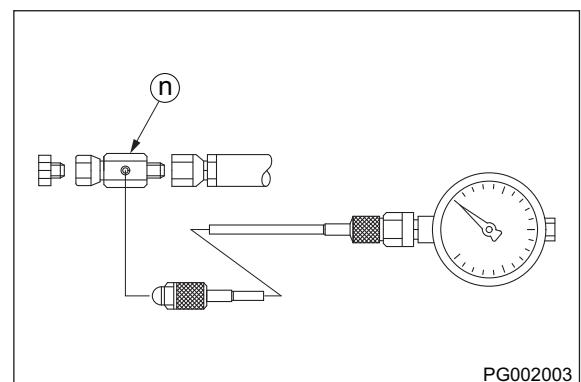
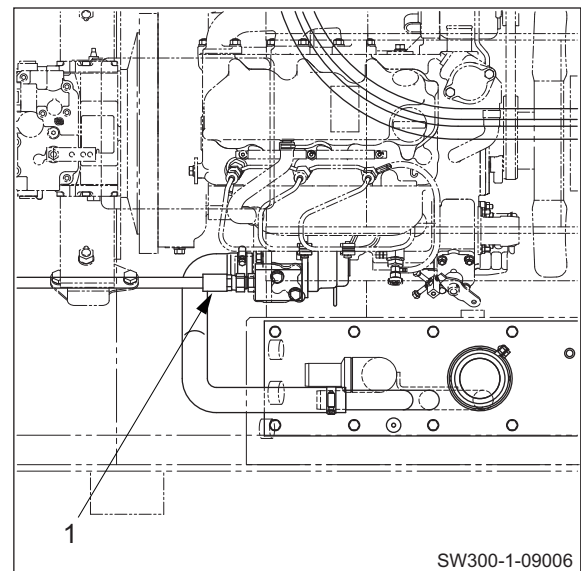

6-2. Inspection

- If measurement results indicate the pressure deviating from standard maximum circuit pressure range, make an adjustment in accordance with procedure described below.
 - ① Remove relief valve (2) from orbitrol.
 - ② Check removed relief valve for trapped dirt, scratches on its seat and other abnormalities.
 - ③ If trapped dirt is present, disassemble and clean relief valve.
 - ④ If a scratch or any other abnormality is found on seat, replace relief valve.
 - ⑤ After inspection, measure pressure again and check that pressure reaches standard maximum circuit pressure range.

(NOTICE)

- **Carefully disassemble and reassemble after taking steps to prevent foreign material from getting in.**

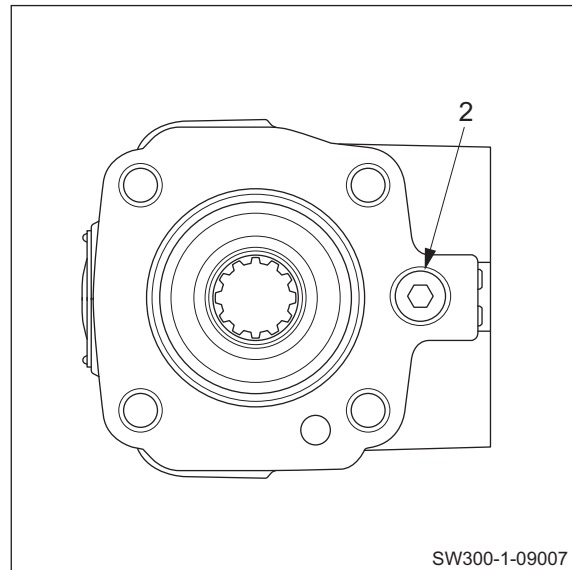

7. MEASUREMENT OF HYDRAULIC PUMP CASE PRESSURE

7-1. Measurement of Propulsion Pump Case Pressure

- Oil temperature during measurement : $50 \pm 5^{\circ}\text{C}$ ($122 \pm 41^{\circ}\text{F}$)
 - ① Disconnect hose from propulsion pump. Attach pressure gauge with adapter ② .
 - Adapter ② : 1 1/16-12UN
 - Pressure gauge : 0 to 5 MPa (0 to 725 psi)
 - ② Start the engine and set throttle lever to "Full".
 - ③ Establish a condition in which machine propulsion load becomes maximum. (Pressure does not build up unless propulsion load is applied.)
 - ④ With propulsion load at maximum, measure pressure when F-R lever is in "N", "F", and "R", respectively.

★ Pump case pressure : 0.25 MPa (36.3 psi) or less

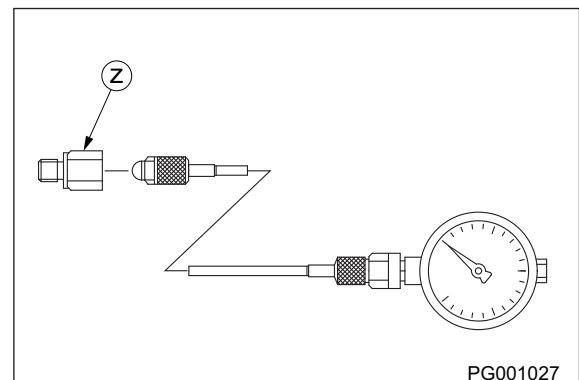
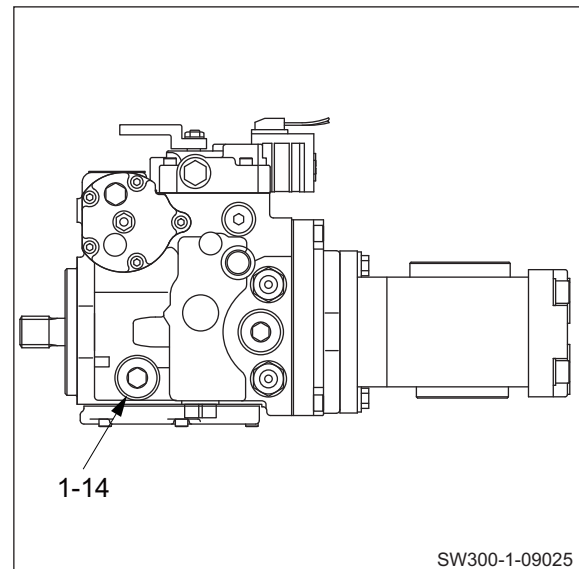

- The number "1-14" appearing in above illustrations is consistent with lead line numbers shown in illustration of propulsion pump in "2-2. Hydraulic Component Specifications" (page 4-010).

8. MEASUREMENT OF PROPULSION MOTOR CASE PRESSURE

8-1. Measurement

8-1-1. SW types: front and rear, TW types: front

- Oil temperature during measurement : $50 \pm 5^{\circ}\text{C}$ ($122 \pm 41^{\circ}\text{F}$)
- ① Disconnect hose (1) from propulsion motor. Attach pressure gauge through adapter (n) .
 - Adapter (n) : G3/8
 - Pressure gauge : 0 to 5 MPa (0 to 725 psi)
- ② Start the engine and set throttle lever to "Full".
- ③ Establish a condition in which machine propulsion load becomes maximum. (Pressure does not build up unless propulsion load is applied.)
- ④ With propulsion load at maximum, measure pressure when F-R lever is in "N", "F", and "R", respectively.

★ Motor case pressure : 0.3 MPa (43.5 psi) or less

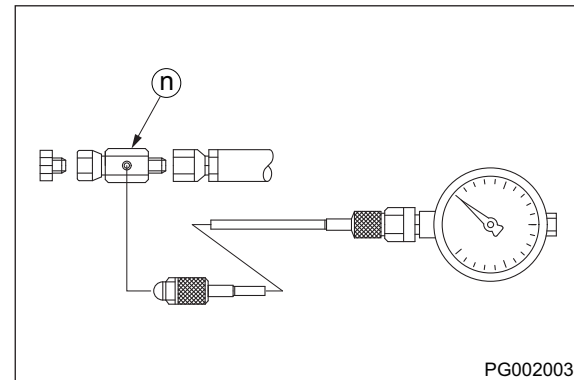
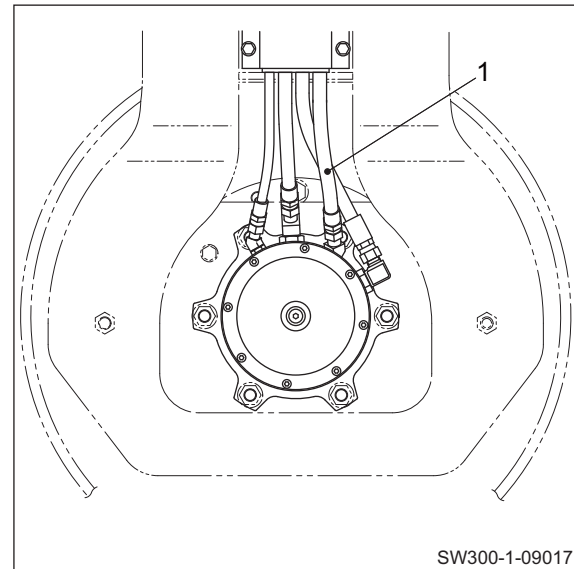

8-1-2. TW types: rear

- Oil temperature during measurement : $50 \pm 5^{\circ}\text{C}$ ($122 \pm 41^{\circ}\text{F}$)
- ① Disconnect hose (2) and (3) from propulsion motor. Attach pressure gauge through adapter (n) .
 - Adapter (n) : G3/8
 - Pressure gauge : 0 to 5 MPa (0 to 725 psi)
- ② Start the engine and set throttle lever to "Full".
- ③ Establish a condition in which machine propulsion load becomes maximum. (Pressure does not build up unless propulsion load is applied.)
- ④ With propulsion load at maximum, measure pressure when F-R lever is in "N", "F", and "R", respectively.

★ **Motor case pressure : 0.3 MPa (43.5 psi) or less**

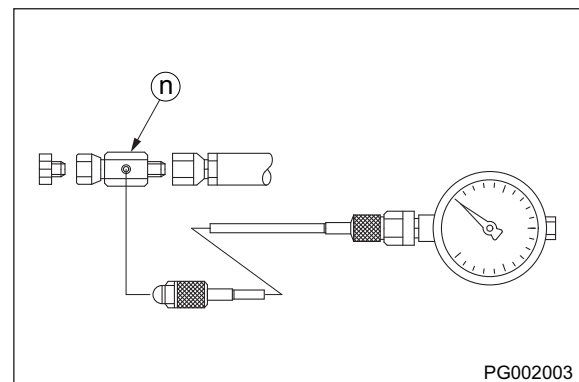
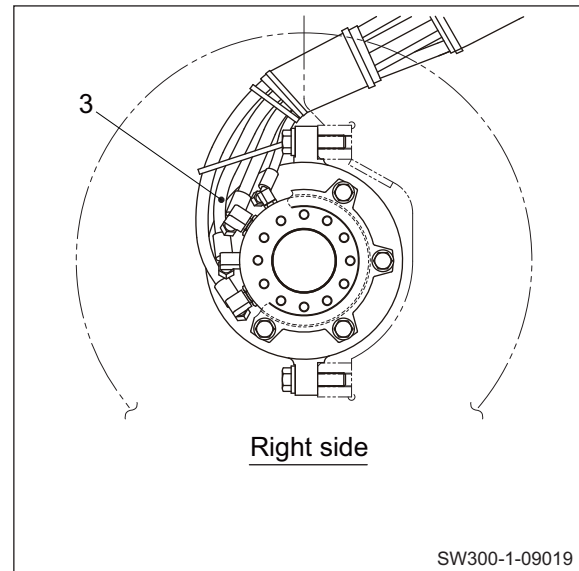
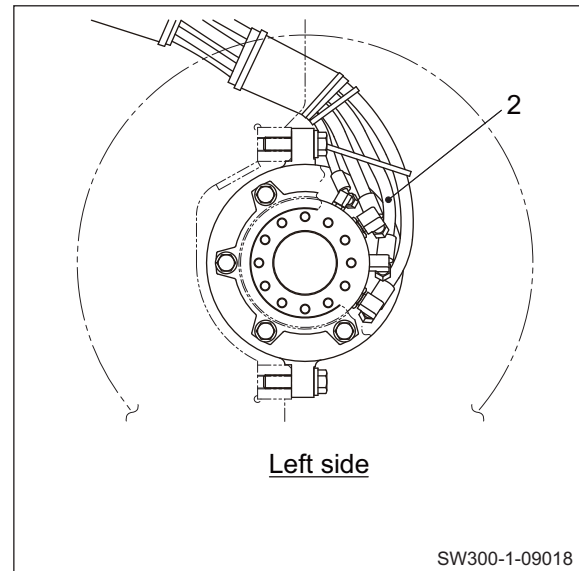

9. ADJUSTMENT OF THROTTLE LEVER LINKAGE

9-1. Adjustment

- In cases such as maximum no-load rotational speed or minimum no-load rotational speed deviating from standard value, control cable is replaced, or throttle lever does not move smoothly, make an adjustment in accordance with procedure described below.
- Make the adjustment after amply warming up engine.
- Oil temperature during measurement : $50 \pm 5^{\circ}\text{C}$ ($122 \pm 41^{\circ}\text{F}$)

- ① Set throttle lever (1) to "IDLE".
- ② Attach control cable (2) to throttle lever (1).
- ③ Attach control cable (2) to fuel injection pump's control lever.
- ④ Start the engine.
- ⑤ Loosen lock nut (4).
- ⑥ Using stopper bolt (3), adjust so that standard minimum no-load rotational speed is achieved.

★ **Standard minimum no-load rotational speed**
: $1,050 \pm 50$ rpm

- ⑦ Using lock nut (4), firmly secure stopper bolt (3).

- ⑧ Set throttle lever (1) to "FULL".
- ⑨ Loosen lock nut (6).
- ⑩ Using stopper bolt (5), adjust so that standard maximum no-load rotational speed is achieved.

★ **Standard maximum no-load rotational speed**
: $2,900 \pm 50$ rpm or less

- ⑪ Using lock nut (6), firmly secure stopper bolt (5).

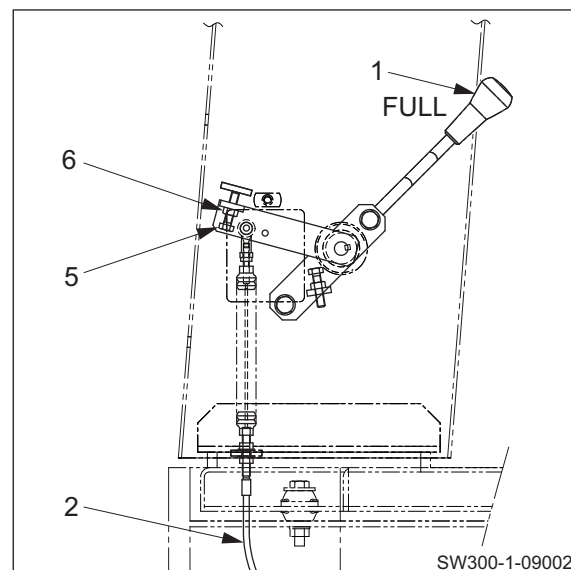
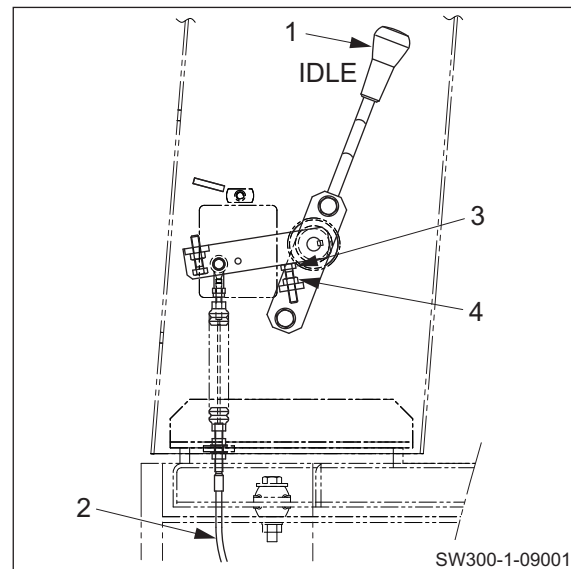

10. ADJUSTMENT OF F-R LEVER LINKAGE

10-1. Adjustment

- In cases such as propulsion hydraulic pump is replaced, control cable is replaced, or F-R lever does not move smoothly, make an adjustment in accordance with procedure described below.
- “N”, maximum “F”, and maximum “R” positions of F-R lever (1) are positioned by notches.

- ① Set F-R lever in “N”.
- ② Attach control cable (2) to F-R lever (1).

★ Specified dimension a: 235.5 mm (9.27 in.)

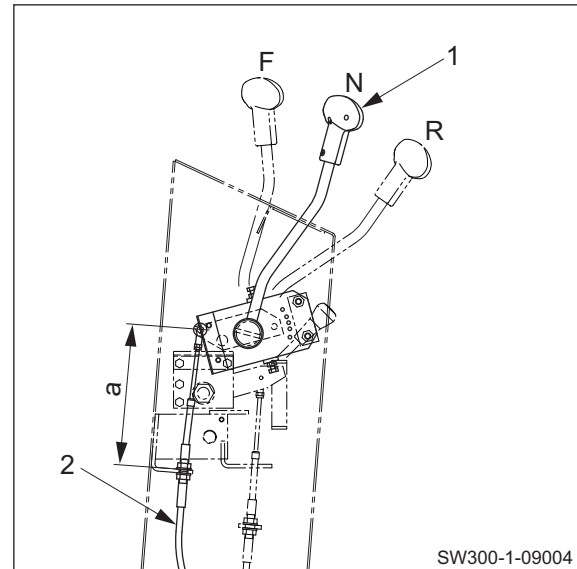

- ③ Attach control cable (2) to propulsion hydraulic pump control lever (3).

★ Specified dimension b: 253.2 mm (9.97 in.)

- ④ Confirm strokes of propulsion hydraulic pump control lever (3).

★ Specified dimension c: 21 mm (0.8 in.)

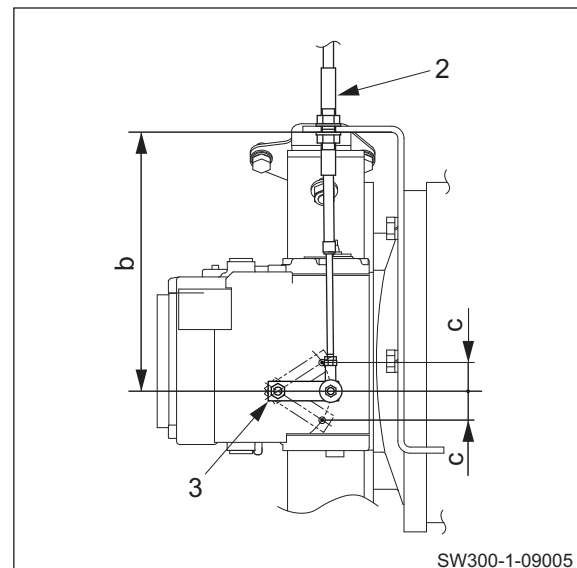

INSPECTION AND ADJUSTMENT

- ⑤ Set F-R lever in "F".
- ⑥ Loosen lock nut (5).
- ⑦ Touch stopper bolt (4) to F-R lever.
- ⑧ Tighten lock nut (5).

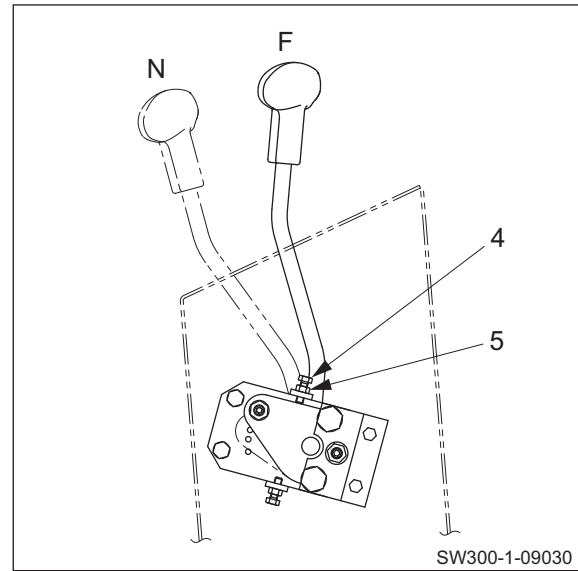

- ⑨ Set F-R lever in "R".
- ⑩ Loosen lock nut (6).
- ⑪ Touch stopper bolt (7) to F-R lever.
- ⑫ Tighten lock nut (6).

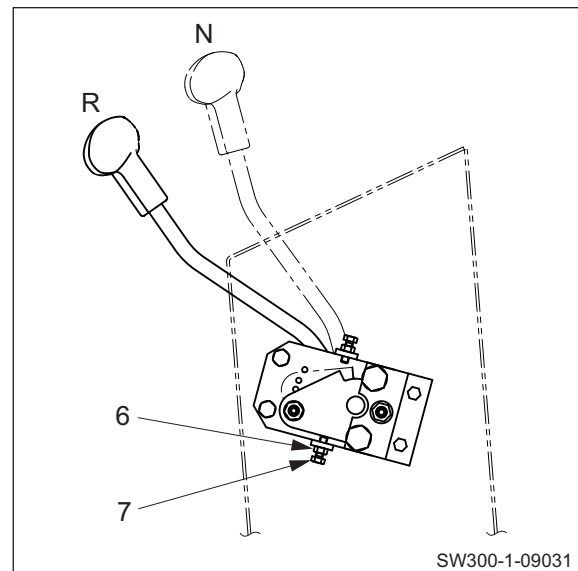

TROUBLESHOOTING

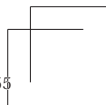
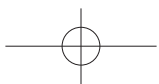
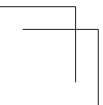
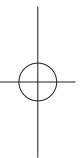
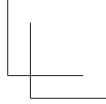
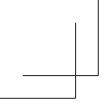

1. TROUBLESHOOTING

1-1. Safety Precautions for Troubleshooting

WARNING

Unexpected machine movement may cause a serious accident. When inspecting the machine while the engine is running, always follow the instructions below.

- Park the machine on level, flat ground.
- Apply the parking brake.
- Set chocks in front and behind each drum or tire.
- Make sure that service personnel are given the appropriate information at the appropriate time.
- Make sure that no one can enter any hazardous area.

CAUTION

Do not work on the hydraulic system while the engine is running and the system is hot and under pressure. Do not disconnect hydraulic hoses or fittings until the system has cooled and pressure has been properly relieved.

Before removing any plugs from the pressure measurement ports, always release any residual pressure from the piping and open the cap of the fluid tank to release and pressure.

WARNING

Inadvertent starting the engine may cause a serious accident.

When inspecting the engine, make sure to exchange the appropriate cues and hand signal with the person at the operator station to avoid any accidents.

CAUTION

Before inspecting inside of the engine compartment, always stop the engine.

Contact with the fan, V-belt or exhaust system parts while the engine is running may cause serious injury.

1-2. Important Information for Troubleshooting

Before conducting troubleshooting, it is important to carefully read the operation manual and workshop manual and understand the electric circuits for each component as well as the structure and function of each system. Sufficient knowledge of the systems will enable you to identify a possible cause much faster. A fault or problem may seem to be related to many different factors. To identify the true cause, some experience is needed. To perform the appropriate troubleshooting, it is important to learn not only the normal operations of the systems but also the possible symptoms that may occur when an abnormal condition is present.

This chapter explains the possible causes and remedies for likely incidents taken from past experience.

TROUBLESHOOTING

1-3. Before Starting

The information in this section is provided to assist the troubleshooter in understanding the systems and quickly determine the causes when operating abnormalities occur.

The following steps are recommended:

1. If not familiar with the machine, study the Operator's Manual and this Shop Manual.
2. Check with the operator for full details of the trouble, ask questions.
3. Verify the trouble by warming up the machine and operating it. Check the problem yourself.
4. Identify the problem with either a mechanical, hydraulic or electrical system source.
5. Isolate the problem to a particular component or circuit.
6. Eliminate the simplest or easiest to check possibilities first to prevent unnecessary disassembly of components.
7. Following repair or replacement of any parts, perform operational tests to verify that the problem has been eliminated and the performance of all the systems is normal.

1-4. Wire Color Code and Number

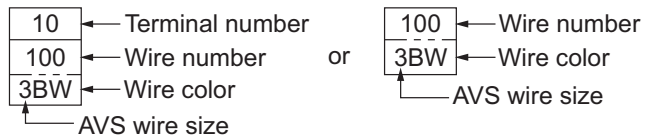

GW750-2-10001

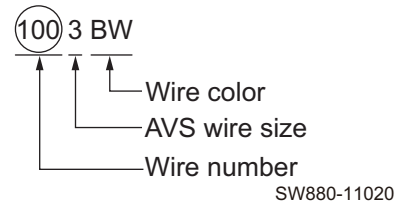

SW880-11020

- The arrangement of connector terminals shown above is that of connecting surfaces on the connector side.

- Wire number, wire size and wire color are shown as above in electrical circuit diagrams.

B	Black	BW	Black/White stripe	BY	Black/Yellow stripe	BR	Black/Red stripe	BG	Black/Green stripe	BL	Black/Blue stripe			O	Orange	YO	Yellow/Orange stripe
W	White	WR	White/Red stripe	WB	White/Black stripe	WL	White/Blue stripe	WY	White/Yellow stripe	WG	White/Green stripe					LO	Blue/Orange stripe
R	Red	RW	Red/White stripe	RB	Red/Black stripe	RY	Red/Yellow stripe	RG	Red/Green stripe	RL	Red/Blue stripe					GO	Green/Orange stripe
G	Green	GW	Green/White stripe	GR	Green/Red stripe	GY	Green/Yellow stripe	GB	Green/Black stripe	GL	Green/Blue stripe			Gy	Gray	GyR	Gray/Red stripe
Y	Yellow	YR	Yellow/Red stripe	YB	Yellow/Black stripe	YG	Yellow/Green stripe	YL	Yellow/Blue stripe	YW	Yellow/White stripe					GyL	Gray/Blue stripe
Br	Brown	BrW	Brown/White stripe	BrR	Brown/Red stripe	BrY	Brown/Yellow stripe	BrB	Brown/Black stripe	BrG	Brown/Green stripe	BrL	Brown/Blue stripe	Sb	Sky blue		
L	Blue	LW	Blue/White stripe	LR	Blue/Red stripe	LY	Blue/Yellow stripe	LB	Blue/Black stripe	LG	Blue/Green stripe			P	Pink	PB	Pink/Black stripe
Lg	Light green	LgR	Light green/Red stripe	LgY	Light green/Yellow stripe	LgB	Light green/Black stripe	LgW	Light green/White stripe	LgL	Light green/Blue stripe			Pu	Purple		

2. ELECTRICAL SYSTEM TROUBLESHOOTING

2-1. When Performing Electrical System Fault Diagnosis

WARNING

Be very careful because equipment can return to normal during an inspection and suddenly operate properly when a failure occurs due to a faulty contact or other such cause.

2-1-1. Precautions to take during electrical circuit fault diagnosis

- When disconnecting or connecting a connector, be sure to turn the power supply OFF. (Electronic control parts such as the engine control unit, in particular, could be damaged internally.)
- Since connectors are not numbered, be sure to affix alignment marks so that you can restore them to their original condition.
- Before making a diagnosis, check related connectors for faulty connections. (Check by disconnecting and reconnecting related connectors several times.)
- Before proceeding to the next step, be sure to return the disconnected connectors to their original condition.
- When diagnosing a circuit (measuring the voltage, resistance, continuity and current), move related wiring and connectors several times, and check whether the tester's numerical values change. (If values change, faulty contact in the circuit is possible.)
- Do not ground the circuit of the control unit or apply voltage to it unless otherwise specified.

TROUBLESHOOTING

2-1-2. Inspection procedures using a tester

Some of the various inspection procedures are presented here for reference, using a sample circuit below.

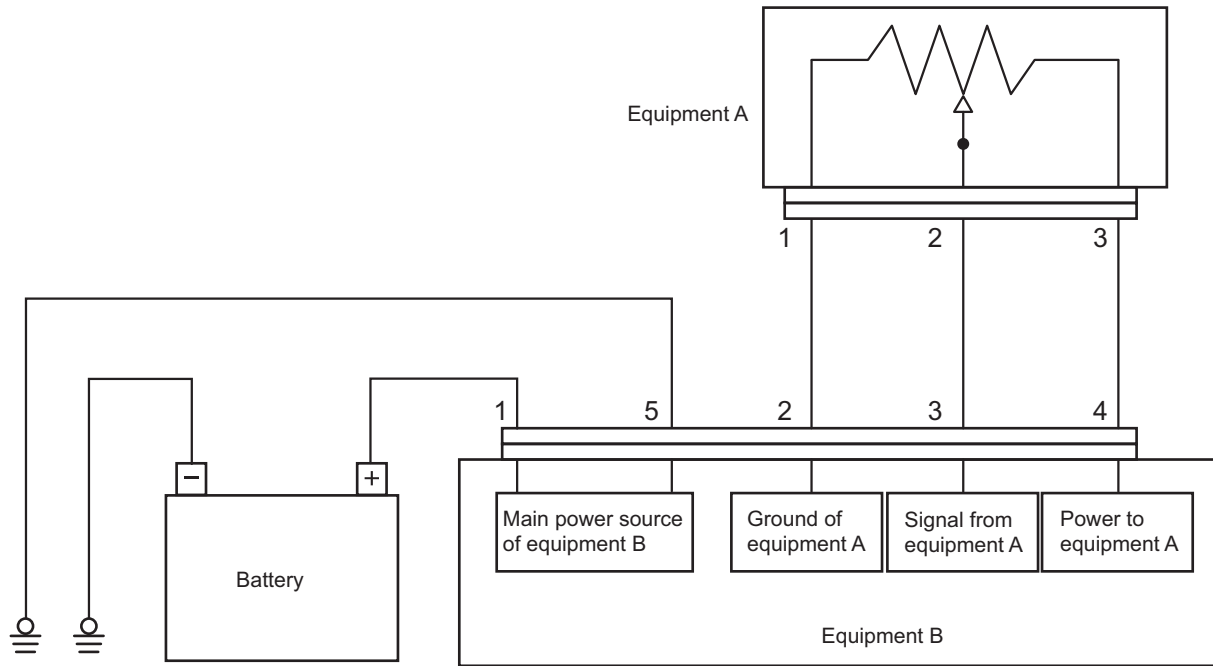

GW750-2-10003

1) Measuring resistance using tester

1-1) Measuring resistance of equipment A (measuring resistance between terminals 1 and 3)

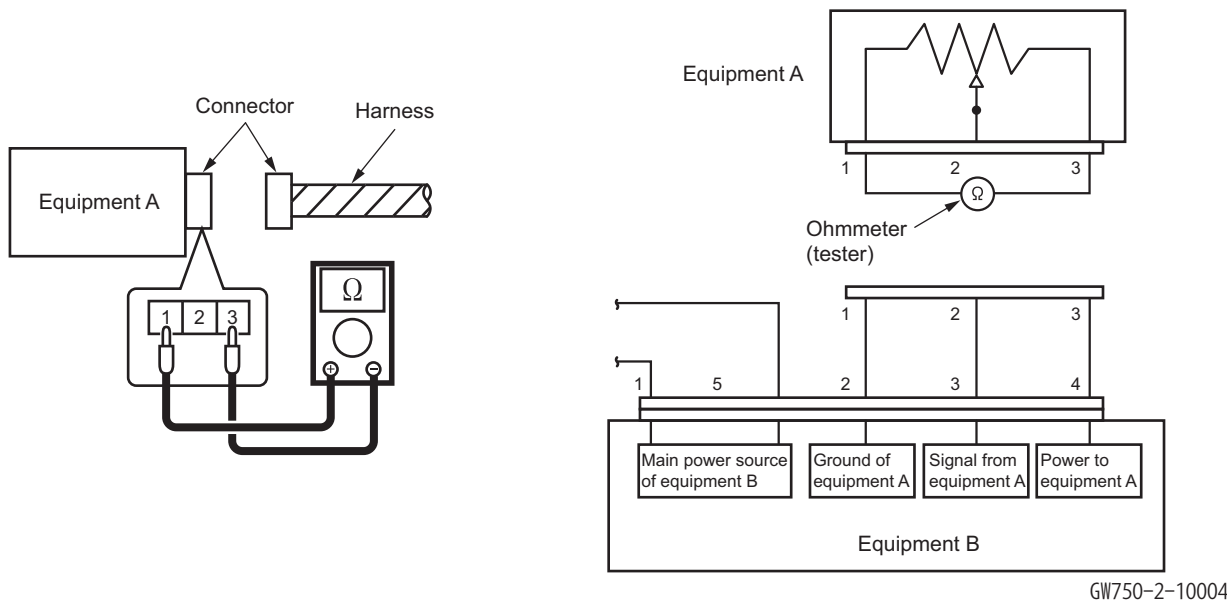

GW750-2-10004

Inspection procedure

- ① Disconnect the connector of equipment A.
- ② Connect the test probe (+) to connector terminal 1 of equipment A and the test probe (-) to connector terminal 3 of equipment A and measure the resistance. At this time, reversing the connector terminals between the probes (+) and (-) does not make any difference in the measurement.

- 1-2) Measuring resistance of harness (measuring resistance between terminal 1 of equipment A and terminal 2 of equipment B)

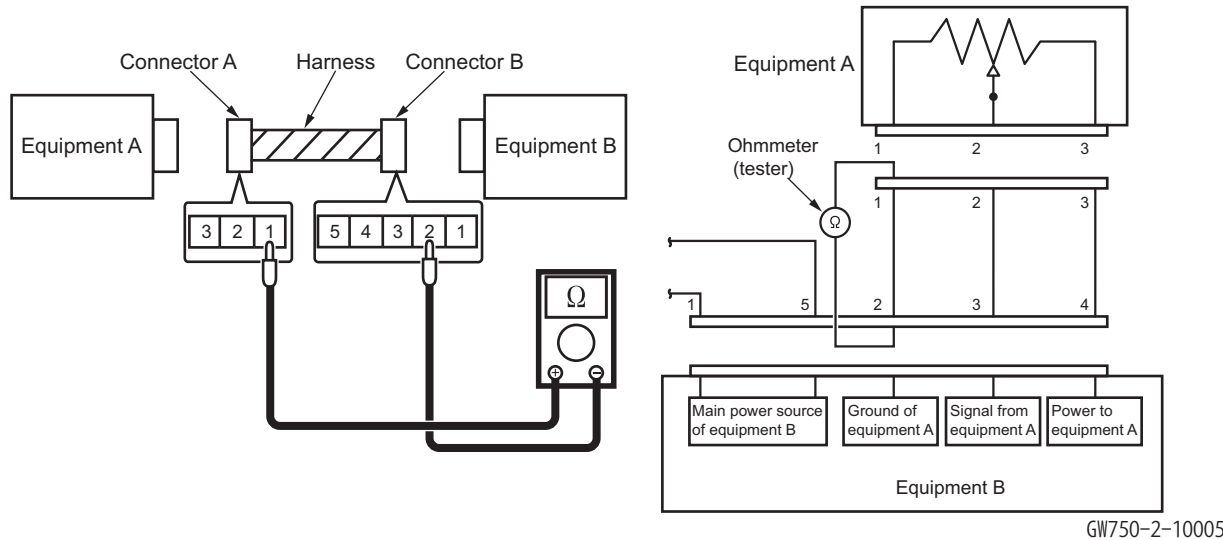

Inspection procedure

- ① Disconnect the connectors of equipment A and equipment B.
- ② Connect the test probe (+) to connector terminal 1 of equipment A and the test probe (-) to connector terminal 2 of equipment B and measure the resistance. At this time, reversing the connector terminals between the probes (+) and (-) does not make any difference in the measurement.

Criteria for harness defects

When there is no abnormality in the harness: Less than 10 Ω (measured value)

If there is any abnormality in the harness such as broken wire: 10 Ω or higher (measured value)

- 1-3) Measuring resistance of grounding wire (measuring resistance between terminal 5 of equipment B and ground)

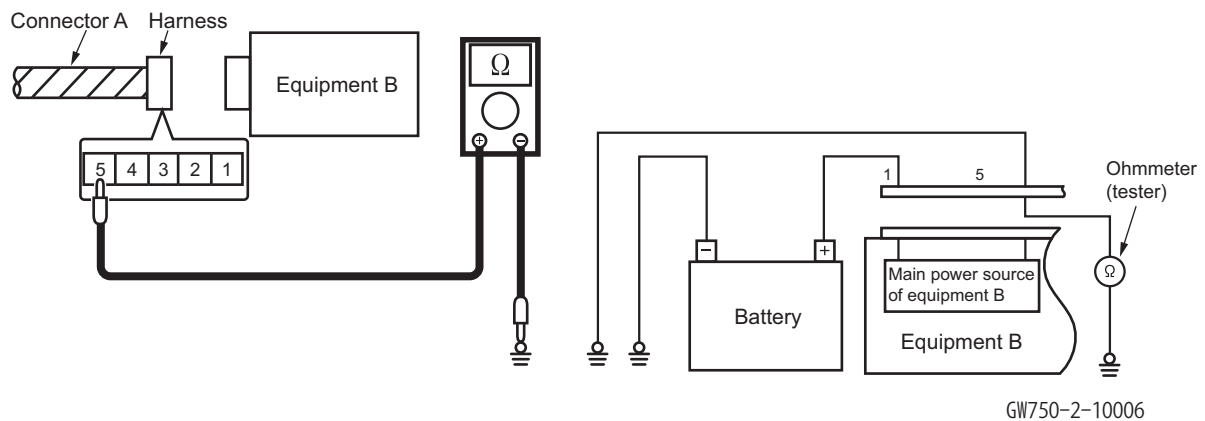

Inspection procedure

- ① Disconnect the connector of equipment B.
- ② Connect the test probe (+) to connector terminal 5 of equipment B and the test probe (-) to a machine ground point (the bolt fastening the ground terminal or an unpainted portion on the body) and measure the resistance. At this time, reversing the connector terminals between the probes (+) and (-) does not make any difference in the measurement.

(NOTICE)

- When measuring the resistance, connect the test probes to both ends of the portion to be measured. Make also sure that no voltage is applied to the portion to be measured.
- When measuring the internal resistance of equipment, be sure first to disconnect all harnesses from the equipment.
- When measuring the resistance of a harness, disconnect the equipment connected to both ends of the harness.

TROUBLESHOOTING

2) Measuring voltage and current flowing using tester

2-1) Measuring voltage of equipment A (measuring voltage between terminals 1 and 3)

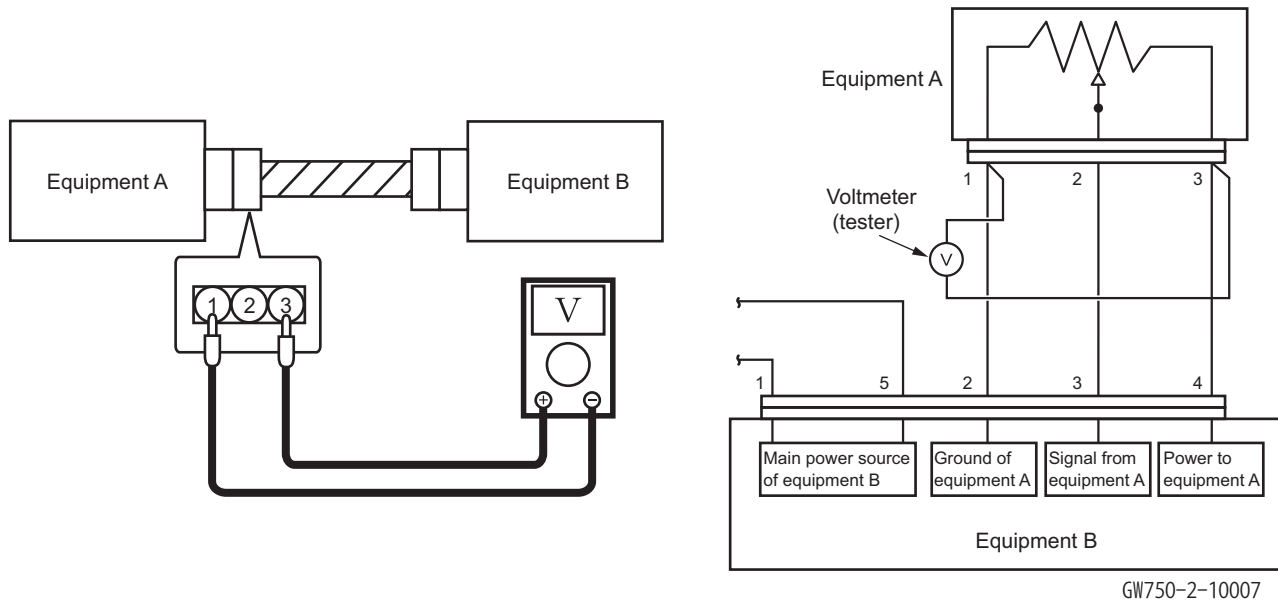

Inspection procedure

- ① Connect the connectors of equipment A and that of equipment B.
- ② Connect the test probe (+) to connector terminal 3 of equipment A and the test probe (-) to connector terminal 1 of equipment A and measure the voltage. Note that reversing the connector terminals between the probes (+) and (-) changes the result of the measurement. Be sure to connect the probe (+) to the power source side and the probe (-) to the ground side.

- Measurement using a test harness

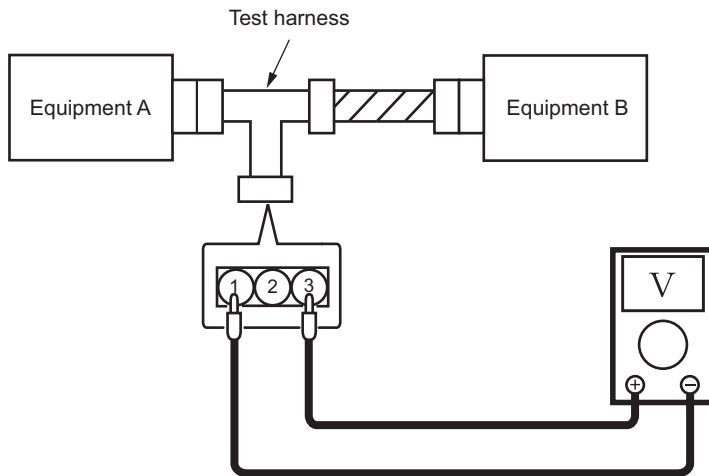

- Measurement from the backside of connector

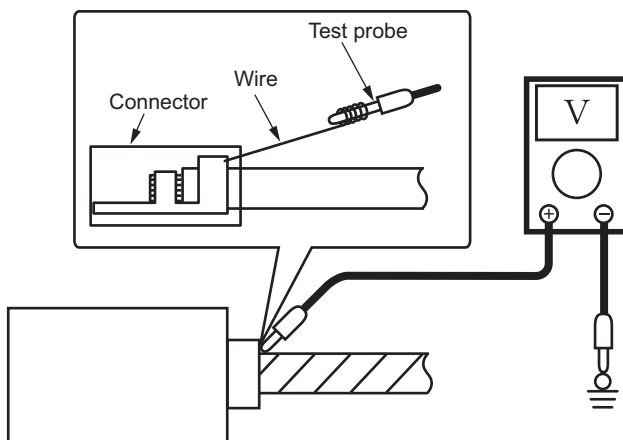

- Measurement on a lead cable

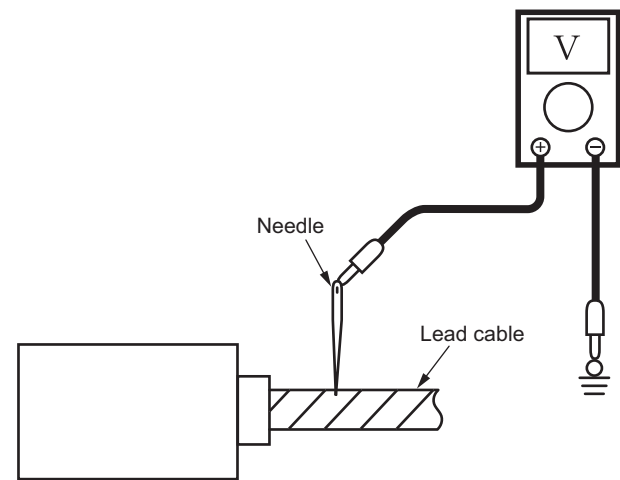

GW750-2-10002

Measurement method

For measurement of voltage, connect the tester probes in parallel to the portion to be measured. Because the voltage can be measured only when the connector is connected in position, contact the tester probes to the terminals without disconnecting the connector. The following methods are available:

- Measurement using a test harness
 - Prepare the test harness for the measurement.
- Measurement from the backside of connector
 - Insert a wire from the backside of the connector.
- Measurement on a lead cable
 - Remove the bundling tape from the harness to separate each cable, and stick the needle into the relevant cable.

(NOTICE)

- Except for preparing the test harness, proper protection must be made after the measurement to prevent corrosion in the connector terminals or harnesses.

TROUBLESHOOTING

- 2-2) Measuring current flowing from equipment B to equipment A
(measuring current between terminal 2 of equipment B and terminal 1 of equipment A)

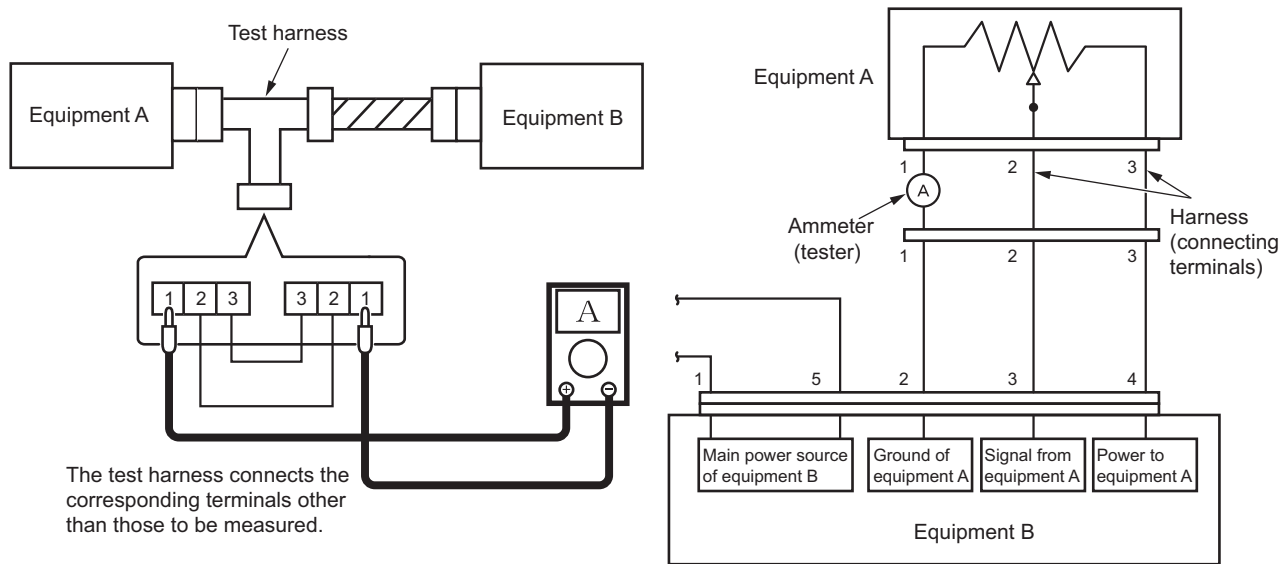

Inspection procedure

- ① Disconnect the connector of equipment A and connect the test harness.
- ② Connect the test probe (+) to connector terminal 1 (harness side) of equipment A and the test probe (-) to connector terminal 1 (equipment side) of equipment A and measure the current. Note that reversing the connector terminals between the probes (+) and (-) changes the result of the measurement. Be sure to connect the probe (+) to the power source side and the probe (-) to the ground side.

Measurement method

When measuring the current, connect the tester in series to the portion to be measured. Because the current cannot be measured when the connector is connected in position, disconnect the connector to allow the test probe to connect between the terminals.

2-1-3. Inspection of electrical system

Operate the applicable switches and turn the relays ON and OFF. Ultimately, if the solenoid valve operates (makes a sound) and the pump runs, the electrical system is OK.

If there is a failure (fault), narrow the range of the inspection to the six broad steps described below.

1) Ground inspection

- Check for disconnected or loose ground. If rust or corrosion is present (which can cause faulty contact), remove the rust.

2) Fuse inspection

2-1) Check for blown fuses, disconnections and corrosion. (A fatigue open circuit cannot be identified visually. Use a tester for checking.)

2-2) If a fuse is blown

Check whether a pump or valve (that is supposed to be protected by a blown fuse) burned, and whether there is a burning odor.

Especially if the pump and valve are not burned, check the harness for signs of burning. If it is burned, replace it.

If a fuse is blown and a relay along the pathway has failed, replace it. And if there is a timer, replace the timer, too. If a switch visually appears to be unsatisfactory (burned, melted, etc.) even though it operates, replace it.

- Simply replacing a fuse may not eliminate the true cause of a problem, and over current may flow again. Also, if over current secondarily causes an electrical path to fail (such as a wiring meltdown inside a solenoid valve), current will not flow. Thus, a fuse may not be blown out, but it also will not operate. If you do not know the location of burning or of an odor, investigate as described follows.

2-3) How to find cause of failure when fuse blown is reproduced

- ① Turn the starter switch OFF, and remove the connector from the load (valve, pump).
- ② Referring to the circuit diagram, remove electrical parts that are connected to the circuit, such as relays, timers and diodes.
- ③ Turn the starter switch ON, and see whether the conditions can be reproduced (fuse is blown).
- ④ If a fuse is blown, a part such as a relay may have caused a short between the previous harness and ground (vehicle body). (Replace the harness.) If the conditions are not reproduced, check for signs of burning (odor) on the removed electrical parts.
- ⑤ If there is no problem, turn the starter switch OFF and reattach the parts.
- ⑥ Turn the starter switch ON and try again.
- ⑦ If a fuse is blown with this action, the problem was caused by a short between the harness and ground (vehicle body) that followed the attached electrical part. (Replace the harness.)
- ⑧ If the conditions are not reproduced, turn the starter switch OFF, and connect the loads (valve and pump) one at a time. Turn the starter switch ON and try again to see whether the fuse blown is reproduced.
- ⑨ If the fuse blown is reproduced, whatever was added at that time (including a harness added electrically) will be the cause of the failure.
 - Even if the fuse is not blown and the valve or pump is not burned, the valve or pump may be damaged electrically and may not operate. There may simply be a disconnection in the interior or an abnormal heat-up.
 - Even if the fuse is not blown, abnormal heat-up (hot enough to cause burns if touched) may occur if a relay, timer, diode or other semiconductor fails.

TROUBLESHOOTING

3) Connector inspection

- Is a connector disconnected or loose?
- Check that pins are not snapped or corroded.
- If faulty contact is suspected

Turn the starter switch OFF. Then disconnect and check the connectors (including relay and switch sockets).

If the terminal has no luster, faulty contact due to oxidation can be suspected. Therefore, polish the terminal by inserting and removing the connector (relay, switch) repeatedly at least five times. (Luster will return.)

4) Relay inspection (Check ON/OFF operation by sound.)

- Conduct without running the engine. (If you run the engine, you cannot hear the sound of operation.)

Sound heard : A relay failure occurred.

No sound heard : Using a tester, check the harness.

Sound heard : A relay failure occurred.

Still no sound : Using a tester, check the harness.

Continuity : Turn the starter switch OFF temporarily, disconnect the relay and check for continuity between the harness-side grounding terminal (color: black) and vehicle body ground. (If there is none, replace the harness.)

Voltage : With the relay disconnected, turn the starter switch ON and turn the operating switch ON. 24 V (or 12 V) (between vehicle body ground) should not reach the relay coil input terminal. Confirm this. Identify the location (section) to which 24 V (or 12 V) reaches. Then replace the harness or take other action.

5) Solenoid valve inspection (Check ON/OFF operation by sound.)

- Conduct without running the engine. (If you run the engine, you cannot hear the sound of operation.)

Sound heard : The electrical system is normal.

No sound heard : Check with a tester.

Continuity : ① Turn the starter switch OFF temporarily, disconnect the connector and check for continuity between the harness-side grounding terminal (color: black) and vehicle body ground. (If there is none, replace the harness.)

: ② Is the solenoid valve coil burnt?

(Turn the starter switch OFF, disconnect the connector and check the resistance between the solenoid valve terminals.)

Voltage : With the connector disconnected, turn the starter switch ON and check whether 24 V (or 12 V) exists between the harness-side connector and vehicle body ground.

If YES : Replace the valve.

If NO : Investigate and identify the location (section) to which 24 V (or 12 V) reaches. Then replace the harness or take other action.

6) Harness check

- If an incomplete disconnection inside the harness is suspected, wiggle (move) the harness during the relay inspection and solenoid valve inspection to see whether the relay (valve) operates incorrectly.
- Check for burned areas of the harness.
- Turn the starter switch OFF, disconnect the connector and check the continuity, referring to the circuit diagram and wiring coloring.

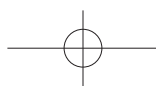
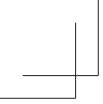

TROUBLESHOOTING

Fig.: 2-2-1

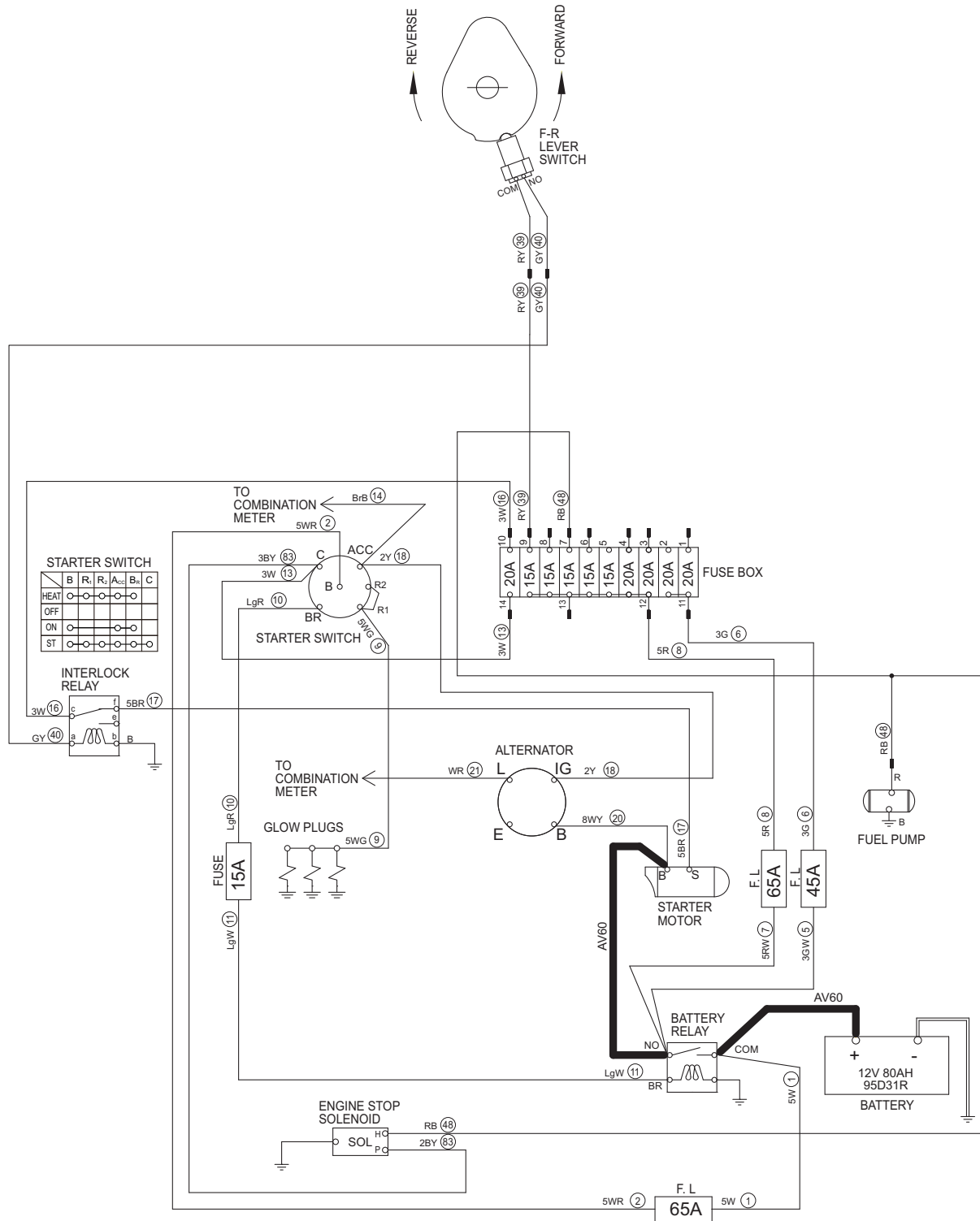

SW300-1-10001

2-2. Engine

Check following items before troubleshooting.

- No blown fuses and power is applied up to fuses.
- Check any ground circuit which belongs to components to be checked.

2-2-1. Engine will not start (Starter motor does not run) 1/2

- F-R lever must be in "N".

Reference Fig.: 2-2-1

Check point	Check/Cause	Action
1. Battery	<ul style="list-style-type: none"> • Measure battery voltage or specific gravity. Standard voltage : 12 V or more Standard gravity : 1.26 or more • If value is below standard, battery capacity is insufficient. 	Charge or replace battery.
2. Starter Switch	<ul style="list-style-type: none"> • Check continuity between O-O according to starter switch connection table. Switch is OK if there is continuity between connection O-O. • If there is no continuity, starter switch is faulty. 	Replace starter switch.
3. Starter Motor	<ol style="list-style-type: none"> (1) When starter switch is ON, measure voltage between starter motor terminal B and chassis ground. Standard voltage : 12 V or more (2) When starter switch is START, measure voltage between starter motor terminal S and chassis ground. Standard voltage : 12 V or more <ul style="list-style-type: none"> • If starter motor does not run even though above items (1) and (2) are OK, starter motor is faulty. 	Replace starter motor.
4. Battery Relay	<ol style="list-style-type: none"> (1) When starter switch is OFF, measure voltage between battery relay primary terminal COM and chassis ground. Standard voltage : 12 V or more (2) When starter switch is ON, measure voltage between battery relay coil terminal BR inlet wire LgW and chassis ground. Standard voltage : 12 V or more (3) When starter switch is ON, measure voltage between battery relay secondary terminal NO and chassis ground. Standard voltage : 12 V or more <ul style="list-style-type: none"> • If above items (1) and (2) are OK and item (3) is NG, battery relay is faulty. 	Replace battery relay.
5. F-R Lever Switch	<ol style="list-style-type: none"> (1) When starter switch is ON, measure voltage between F-R lever switch terminal COM inlet wire RY and chassis ground. Standard voltage : 12 V or more (2) When starter switch is ON, measure voltage between F-R lever switch terminal NO outlet wire GY and chassis ground. There is no electricity in normal condition. <ul style="list-style-type: none"> • If above item (1) is OK and item (2) is NG, F-R lever switch is faulty. 	Replace F-R lever switch.

TROUBLESHOOTING

Fig.: 2-2-1

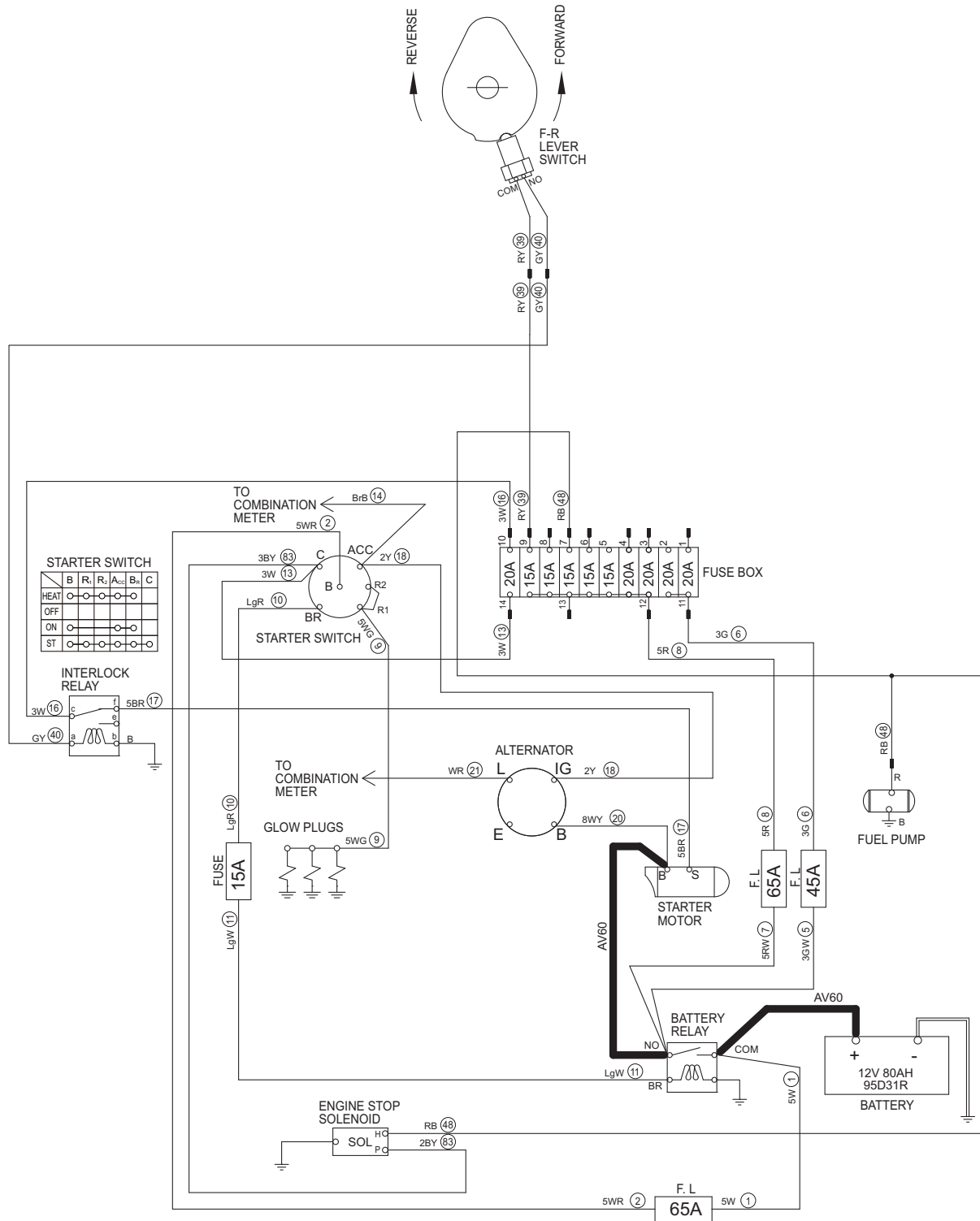

SW300-1-10001

2-2-1. Engine will not start (Starter motor does not run) 2/2

- F-R lever must be in "N".

Reference Fig.: 2-2-1

Check point	Check/Cause	Action
6. Interlock Relay	<p>(1) When starter switch is ON, measure voltage between interlock relay terminal a inlet wire GY and chassis ground. There is no electricity in normal condition.</p> <p>(2) When starter switch is START, measure voltage between interlock relay terminal c inlet wire W and chassis ground. Standard voltage : 12 V or more</p> <p>(3) When starter switch is START, measure voltage between interlock relay terminal f outlet wire BR and chassis ground. Standard voltage : 12 V or more</p> <ul style="list-style-type: none"> • If above items (1) and (2) are OK and item (3) is NG, interlock relay is faulty. 	Replace interlock relay.
7. Harness Connecting Between Terminals	<ul style="list-style-type: none"> • Measure resistance of harness connecting between terminals. Standard resistance : 10 Ω or less • If resistance is abnormal, harness is faulty. 	Repair or replace harness.

TROUBLESHOOTING

Fig.: 2-2-1

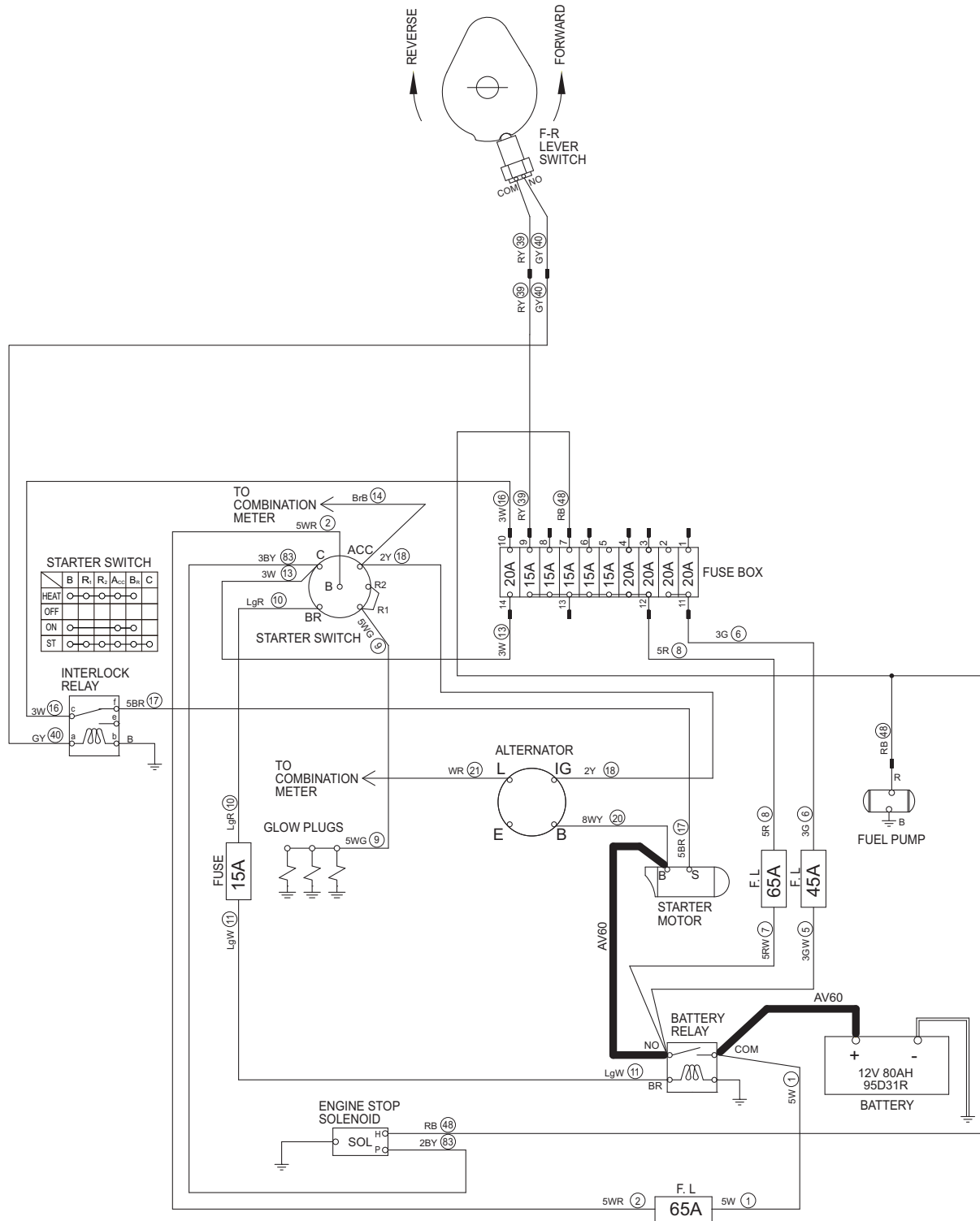

SW300-1-10001

2-2-2. Engine will not start (But starter motor runs)

- In case of engine will not start while starter motor runs, generally trouble is caused by that fuel is not supplied, supply amount of fuel is extremely low, or selection of fuel is not appropriate.
- Check that fuel is supplied to inlet of fuel pump.

Reference Fig.: 2-2-1

Check point	Check/Cause	Action
1. Fuel Pump	<ul style="list-style-type: none"> • When starter switch is ON, measure voltage between fuel pump terminal inlet wire RB and chassis ground. Standard voltage : 12 V or more • If above item is OK and fuel pump does not operate, fuel pump is faulty. 	Repair or replace fuel pump.
2. Engine Stop Solenoid	<p>(1) When starter switch is ON, measure voltage between engine stop solenoid terminal H inlet wire RB and chassis ground. Standard voltage : 12 V or more</p> <p>(2) When starter switch is START, measure voltage between engine stop solenoid terminal P inlet wire BY and chassis ground. Standard voltage : 12 V or more</p> <ul style="list-style-type: none"> • If above items (1) and (2) are OK and engine does not start, engine stop solenoid is faulty. 	Replace engine stop solenoid.
3. Harness Connecting Between Terminals	<ul style="list-style-type: none"> • Measure resistance of harness connecting between terminals. Standard resistance : 10 Ω or less • If resistance is abnormal, harness is faulty. 	Repair or replace harness.

2-2-3. Engine does not stop running

Reference Fig.: 2-2-1

Check point	Check/Cause	Action
1. Engine Stop Solenoid	<p>(1) When starter switch is OFF, measure voltage between engine stop solenoid terminal H inlet wire RB and chassis ground. There is no electricity in normal condition.</p> <p>(2) When starter switch is OFF, measure voltage between engine stop solenoid terminal P inlet wire BY and chassis ground. There is no electricity in normal condition.</p> <ul style="list-style-type: none"> • If above items (1) and (2) are OK and engine does not stop after started, engine stop solenoid is faulty. 	Replace engine stop solenoid.
2. Harness Connecting Between Terminals	<ul style="list-style-type: none"> • Measure resistance of harness connecting between terminals. Standard resistance : 10 Ω or less • If resistance is abnormal, harness is faulty 	Repair or replace harness.

TROUBLESHOOTING

Fig.: 2-2-1

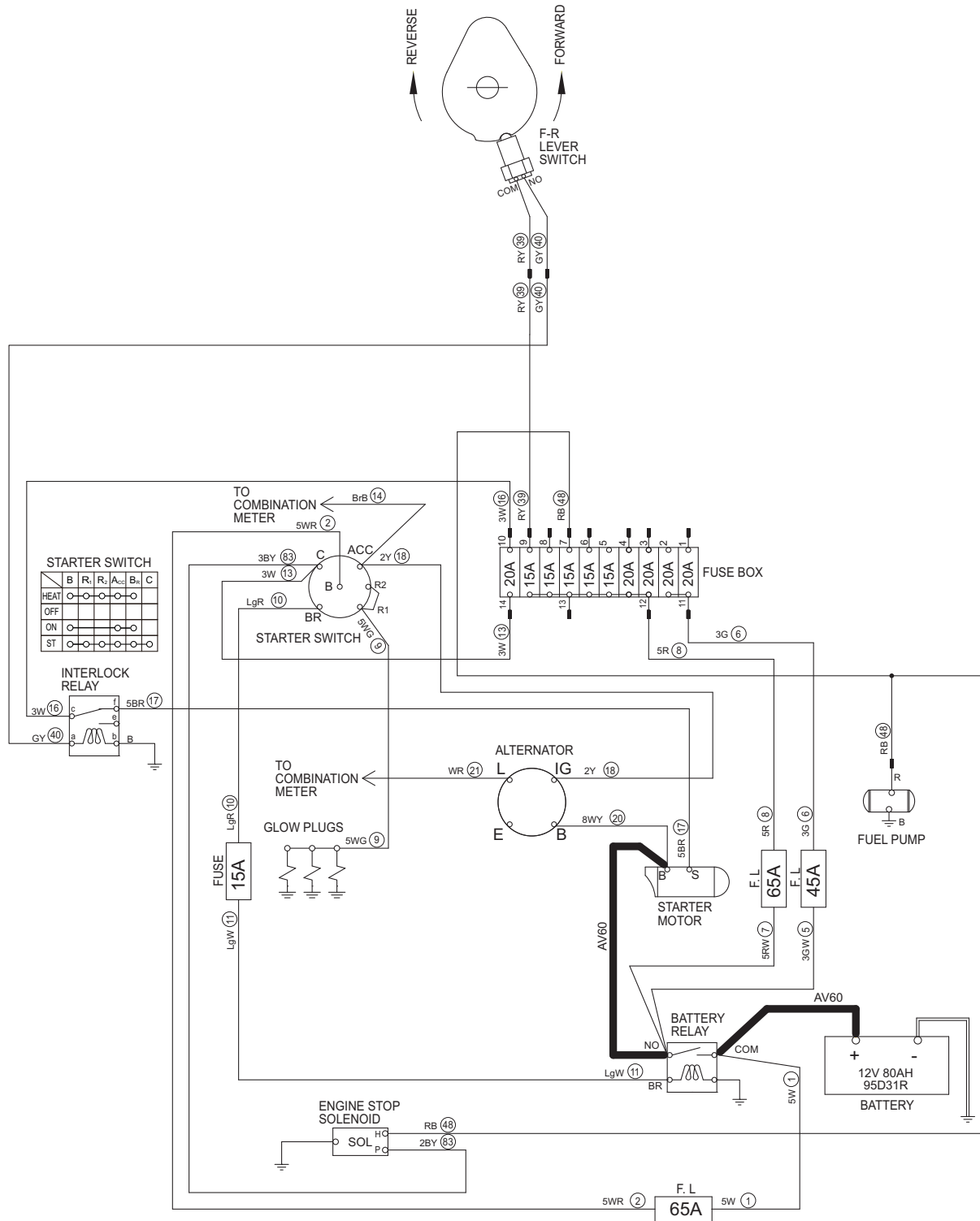

SW300-1-10001

2-2-4. No charging

Reference Fig.: 2-2-1

Check point	Check/Cause	Action
1. Alternator	<ul style="list-style-type: none"> After starting engine, measure voltage between alternator terminal B wire WY and chassis ground. Standard voltage : At least intermediate engine speed, 14 V or more If voltage is lower than standard, alternator is faulty. If voltage is normal and battery is not charged, battery is faulty. 	Replace alternator or battery.

2-2-5. Glow plug is not heated (Engine starting performance is bad in cold weather)

Reference Fig. : 2-2-1

Check point	Check/Cause	Action
1. Starter Switch	<ul style="list-style-type: none"> Check continuity between O-O according to starter switch connection table. Switch is OK if there is continuity between connection O-O. If there is no continuity, starter switch is faulty. 	Replace starter switch.
2. Glow Plug	<ul style="list-style-type: none"> When starter switch is HEAT, measure voltage between glow plug inlet wire WG and chassis ground. Standard voltage : 12 V or more If voltage is normal, glow plug is faulty. 	Replace glow plug.
3. Harness Connecting Between Terminals	<ul style="list-style-type: none"> Measure resistance of harness connecting between terminals. Standard resistance : 10 Ω or less If resistance is abnormal, harness is faulty. 	Repair or replace harness.

2-2-6. Starter motor runs even when F-R lever is not at "N"

Reference Fig.: 2-2-1

Check point	Check/Cause	Action
1. F-R Lever Switch	<ul style="list-style-type: none"> When starter switch is OFF and F-R lever is in "F" or "R", check continuity between F-R lever switch terminal COM and terminal NO. There is continuity in normal condition. If there is no continuity, F-R lever switch is faulty. 	Replace F-R lever switch.

TROUBLESHOOTING

Fig.: 2-3-1

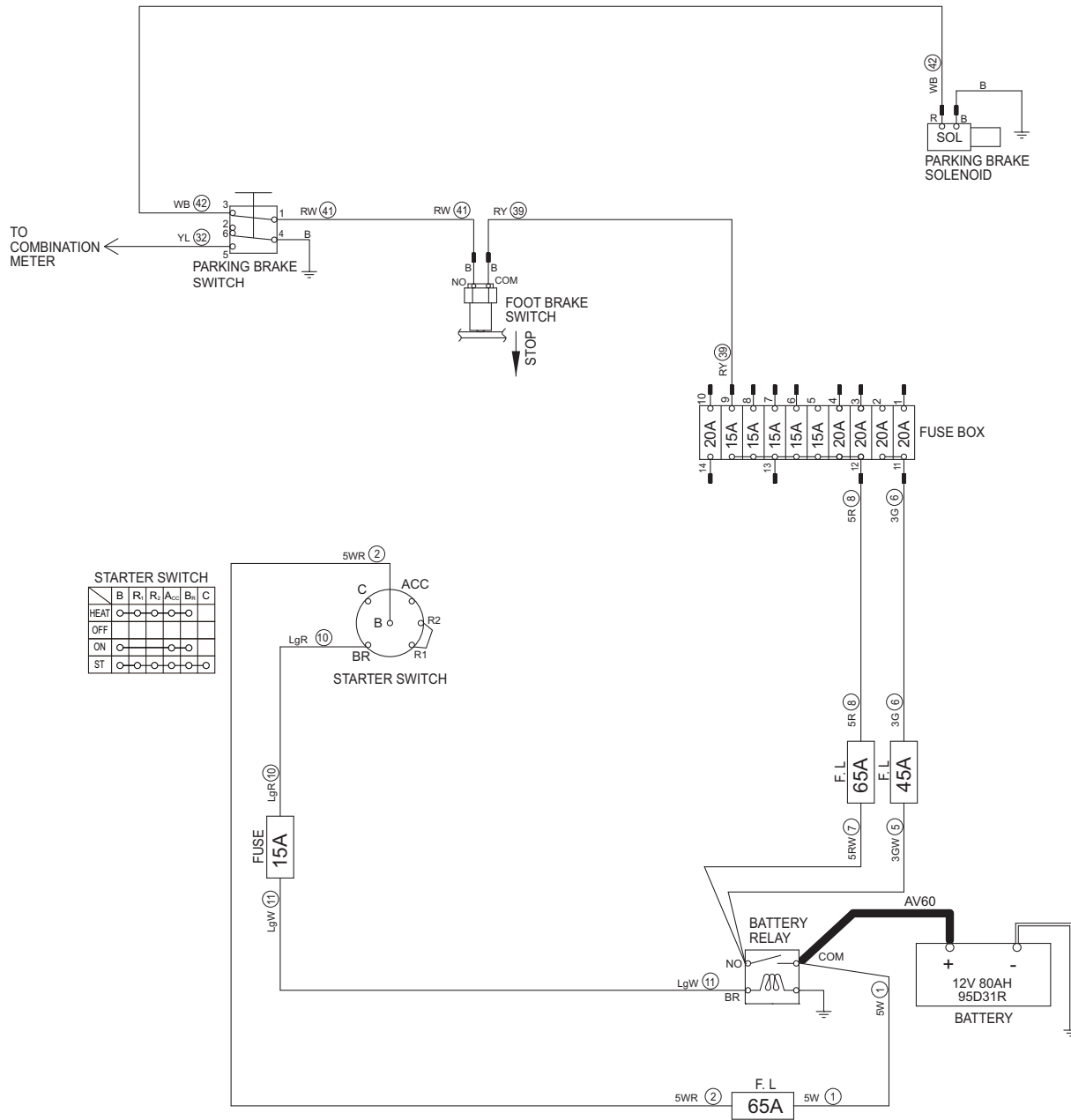

SW300-1-10002

2-3. Propulsion

Check following items before troubleshooting.

- No blown fuses and power is applied up to fuses.
- Check any ground circuit which belongs to components to be checked.

2-3-1. Machine moves neither forward nor backward

- Parking brake switch must be released.
- Foot brake switch must be ON (Brake pedal is not depressed).

Reference Fig.: 2-3-1

Check point	Check/Cause	Action
1. Parking Brake Solenoid	<ul style="list-style-type: none"> • Disconnect harness and measure resistance of coil. Standard resistance : $6.5 \pm 0.3 \Omega$ • If measured resistance is abnormal, parking brake solenoid is faulty. 	Replace parking brake solenoid.
2. Foot Brake Switch	<p>(1) When starter switch is ON, measure voltage between foot brake switch terminal COM inlet wire RY and chassis ground. Standard voltage : 12 V or more</p> <p>(2) When starter switch is ON, measure voltage between foot brake switch terminal NO outlet wire RW and chassis ground. Standard voltage : 12 V or more</p> <ul style="list-style-type: none"> • If above item (1) is OK and item (2) is NG, foot brake switch is faulty. 	Replace foot brake switch.
3. Parking Brake Switch	<p>(1) When starter switch is ON, measure voltage between parking brake switch terminal 1 inlet wire RW and chassis ground. Standard voltage : 12 V or more</p> <p>(2) When starter switch is ON, measure voltage between parking brake switch terminal 3 outlet wire WB and chassis ground. Standard voltage : 12 V or more</p> <ul style="list-style-type: none"> • If above item (1) is OK and item (2) is NG, parking brake switch is faulty. 	Replace parking brake switch.
4. Harness Connecting Between Terminals	<ul style="list-style-type: none"> • Measure resistance of harness connecting between terminals. Standard resistance : 10Ω or less • If resistance is abnormal, harness is faulty. 	Repair or replace harness.

TROUBLESHOOTING

Fig.: 2-3-1

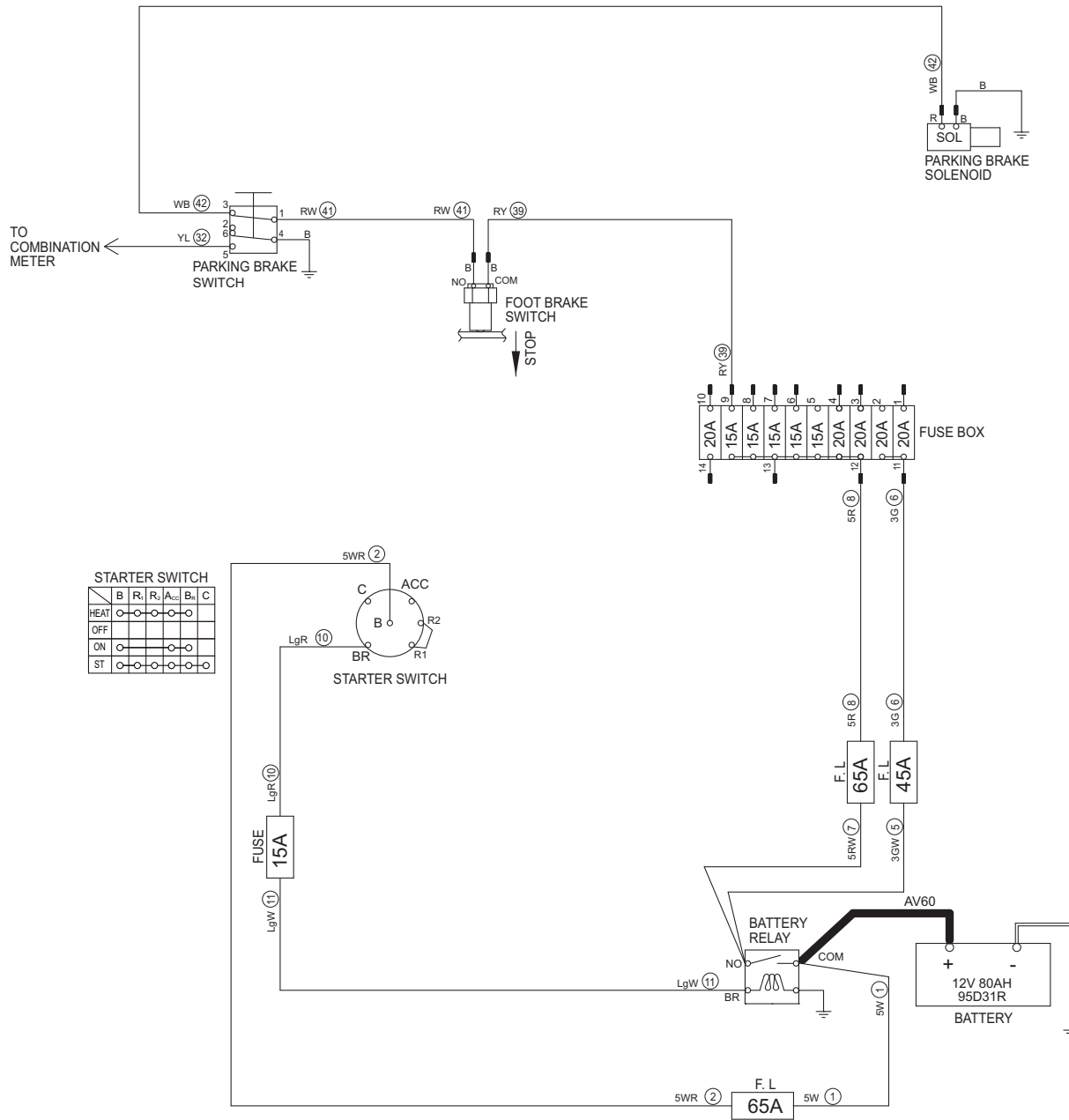

SW300-1-10002

2-3-2. Brake cannot be released

- Parking brake switch must be released.
- Foot brake switch must be ON (Brake pedal is not depressed).

Reference Fig.: 2-3-1

Check point	Check/Cause	Action
1. Parking Brake Solenoid	<ul style="list-style-type: none"> • Disconnect harness and measure resistance of coil. Standard voltage : $6.5 \pm 0.3 \Omega$ • If measured resistance is abnormal, parking brake solenoid is faulty. 	Replace parking brake solenoid.
2. Foot Brake Switch	<p>(1) When starter switch is ON, measure voltage between foot brake switch terminal COM inlet wire RY and chassis ground. Standard voltage : 12 V or more</p> <p>(2) When starter switch is ON, measure voltage between foot brake switch terminal NO outlet wire RW and chassis ground. Standard voltage : 12 V or more</p> <ul style="list-style-type: none"> • If above item (1) is OK and item (2) is NG, foot brake switch is faulty. 	Replace foot brake switch.
3. Parking Brake Switch	<p>(1) When starter switch is ON, measure voltage between parking brake switch terminal 1 inlet wire RW and chassis ground. Standard voltage : 12 V or more</p> <p>(2) When starter switch is ON, measure voltage between parking brake switch terminal 3 outlet wire WB and chassis ground. Standard voltage : 12 V or more</p> <ul style="list-style-type: none"> • If above item (1) is OK and item (2) is NG, parking brake switch is faulty. 	Replace parking brake switch.
4. Harness Connecting Between Terminals	<ul style="list-style-type: none"> • Measure resistance of harness connecting between terminals. Standard resistance : 10Ω or less • If resistance is abnormal, harness is faulty. 	Repair or replace harness.

TROUBLESHOOTING

Fig.: 2-3-1

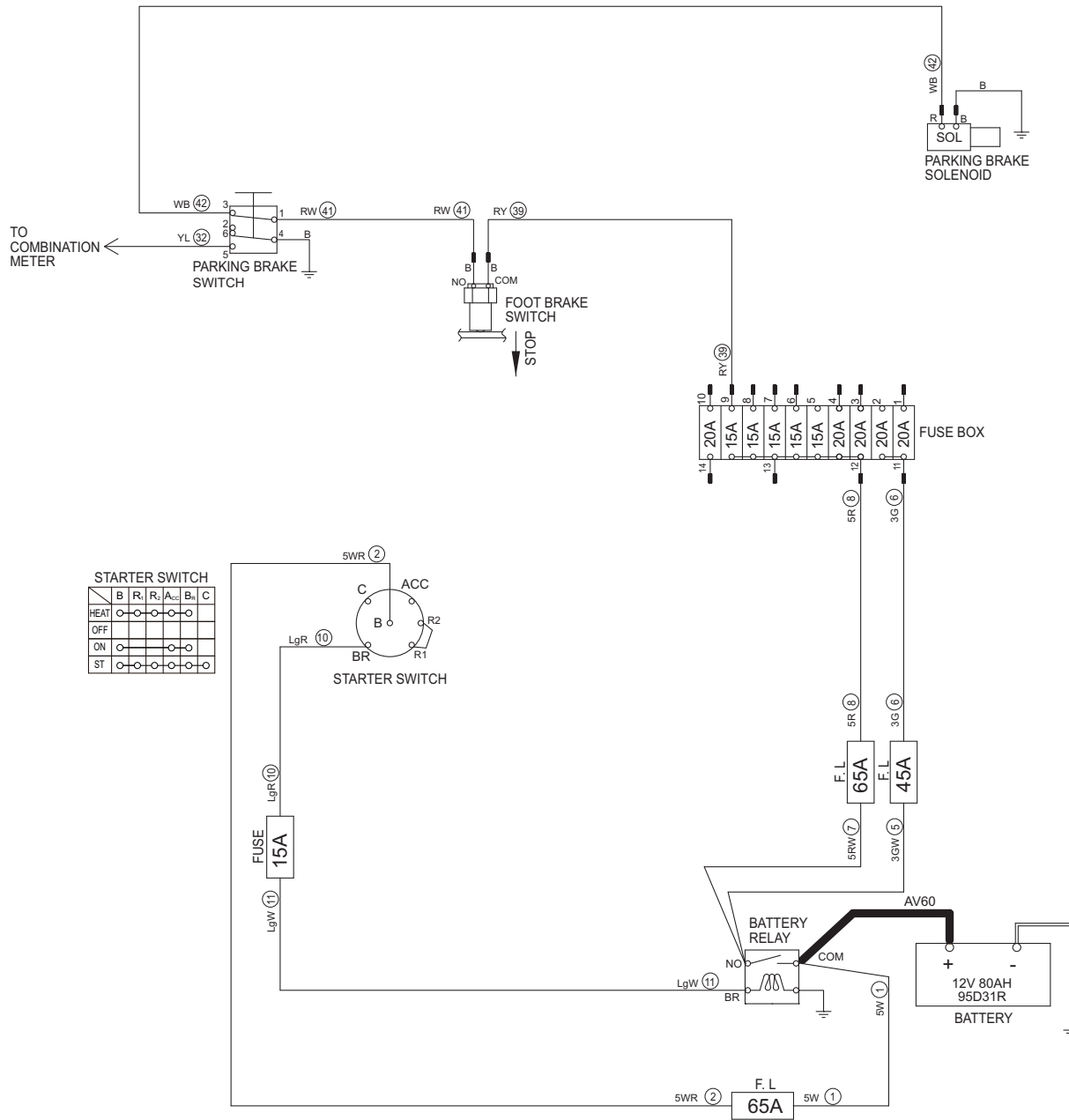

	B	R ₁	R ₂	A ₂	B ₁	C
HEAT	○	○	○	○	○	○
OFF	○	○	○	○	○	○
ON	○	○	○	○	○	○
ST	○	○	○	○	○	○

SW300-1-10002

2-3-3. Brake does not work

- Parking brake switch must be applied.
- Foot brake switch must be OFF (Brake pedal is depressed).

Reference Fig.: 2-3-1

Check point	Check/Cause	Action
1. Parking Brake Solenoid	<ul style="list-style-type: none"> • Disconnect harness and measure resistance of coil. Standard resistance : $6.5 \pm 0.3 \Omega$ • If measured resistance is abnormal, parking brake solenoid is faulty. 	Replace parking brake solenoid.
2. Parking Brake Switch	<ul style="list-style-type: none"> • When starter switch is ON, measure voltage between parking brake switch terminal 3 outlet wire WB and chassis ground. There is no electricity in normal condition. • If electricity flows, parking brake switch is faulty. 	Replace parking brake switch.
3. Foot Brake Switch	<ul style="list-style-type: none"> • When starter switch is ON, measure voltage between foot brake switch terminal NO outlet wire RW and chassis ground. There is no electricity in normal condition. • If electricity flows, foot brake switch is faulty. 	Replace foot brake switch.
4. Harness Connecting Between Terminals	<ul style="list-style-type: none"> • Measure resistance of harness connecting between terminals. Standard resistance : 10Ω or less • If resistance is abnormal, harness is faulty. 	Repair or replace harness.

TROUBLESHOOTING

Fig.: 2-4-1

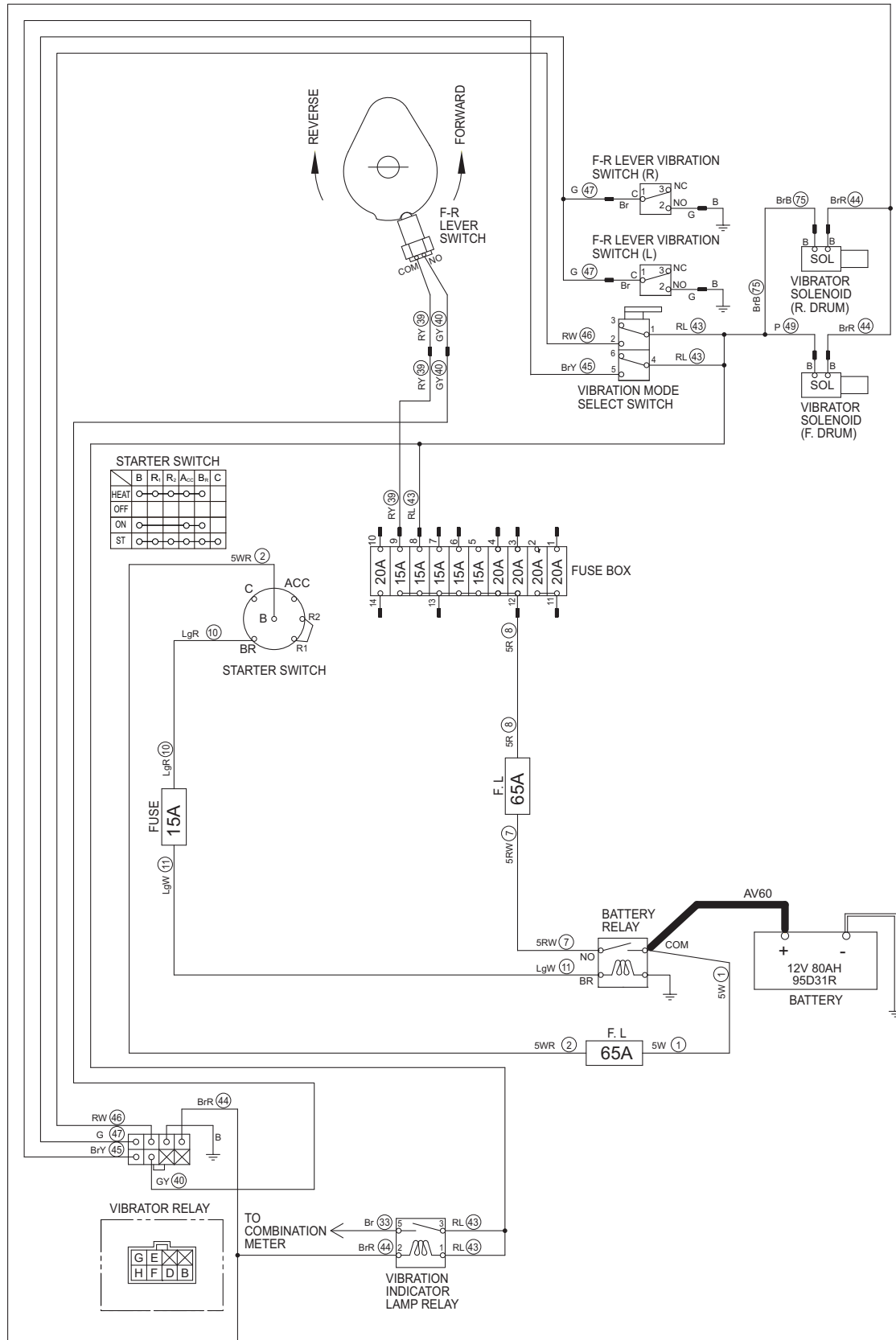

SW300-1-10003

2-4. Vibration

Check following items before troubleshooting.

- No blown fuses and power is applied up to fuses.
- Check any ground circuit which belongs to components to be checked.
- Engine speed is higher than 2,200 min⁻¹ (rpm).

2-4-1. No vibration occurs

- Vibration mode select switch must be "AUTO" (automatic mode).
- F-R lever position must be "F" or "R".

Reference Fig. : 2-4-1

Check point	Check/Cause	Action
1. Vibrator Solenoid	<ul style="list-style-type: none"> • Disconnect harness and measure resistance of coil. Standard resistance : 12 Ω • If resistance is abnormal, vibrator solenoid is faulty. 	Replace vibrator solenoid.
2. Vibration Mode Select Switch	<ol style="list-style-type: none"> (1) When starter switch is ON, measure voltage between vibration mode select switch terminal 4 inlet wire RL and chassis ground. Standard voltage: 12 V or more (2) When starter switch is ON, measure voltage between vibration mode select switch terminal 5 outlet wire BrY and chassis ground. Standard voltage: 12 V or more <ul style="list-style-type: none"> • If above item (1) is OK and item (2) is NG, vibration mode select switch is faulty. 	Replace vibration mode select switch.
3. Vibrator Relay	<ol style="list-style-type: none"> (1) When starter switch is ON, measure voltage between vibrator relay terminal E inlet wire GY and chassis ground. Standard voltage: 12 V or more (2) When starter switch is ON, measure voltage between vibrator relay terminal G inlet wire BrY and chassis ground. Standard voltage: 12 V or more (3) When starter switch is ON, measure voltage between vibrator relay terminal B inlet wire BrR and chassis ground. Standard voltage: 12 V or more (4) Check vibrator relay terminal D wire B is grounded. <ul style="list-style-type: none"> • If above items (1), (2), (3) and (4) are OK and vibration does not occur, vibrator relay is faulty. 	Replace vibrator relay.
4. F-R Lever Switch	<ol style="list-style-type: none"> (1) When starter switch is ON, measure voltage between F-R lever switch terminal COM inlet wire RY and chassis ground. Standard voltage: 12 V or more (2) When starter switch is ON, measure voltage between F-R lever switch terminal NO outlet wire GY and chassis ground. Standard voltage: 12 V or more <ul style="list-style-type: none"> • If above item (1) is OK and item (2) is NG, F-R lever switch is faulty. 	Repair or replace harness.
5. Harness Connecting Between Terminals	<ul style="list-style-type: none"> • Measure resistance of harness connecting between terminals. Standard resistance : 10 Ω or less • If resistance is abnormal, harness is faulty. 	Repair or replace harness.

TROUBLESHOOTING

Fig.: 2-4-1

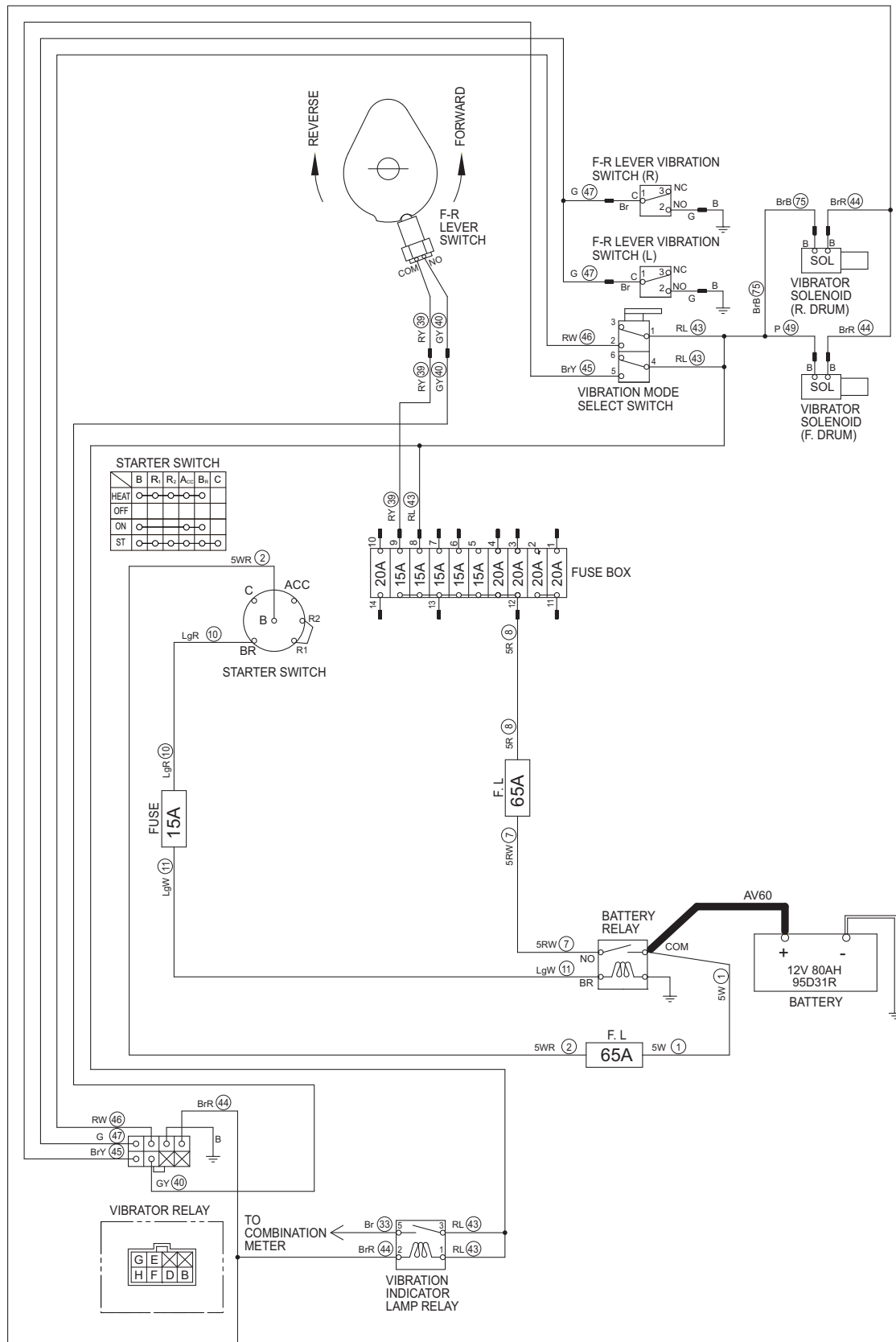

SW300-1-10003

2-4-2. Vibration mode cannot be switched (F-R lever vibration switch does not work)

- Vibration mode select switch must be “” (manual mode).
- F-R lever position must be “F” or “R”.

Reference Fig.: 2-4-1

Check point	Check/Cause	Action
1. Vibrator Solenoid	<ul style="list-style-type: none"> • Disconnect harness and measure resistance of coil. Standard resistance : 12 Ω • If resistance is abnormal, vibrator solenoid is faulty. 	Replace vibrator solenoid.
2. Vibration Mode Select Switch	<p>(1) When starter switch is ON, measure voltage between vibration mode select switch terminal 1 inlet wire RL and chassis ground. Standard voltage: 12 V or more</p> <p>(2) When starter switch is ON, measure voltage between vibration mode select switch terminal 2 outlet wire RW and chassis ground. Standard voltage: 12 V or more</p> <ul style="list-style-type: none"> • If above item (1) is OK and item (2) is NG, vibration mode select switch is faulty. 	Replace vibration mode select switch.
3. Vibrator Relay	<p>(1) When starter switch is ON, measure voltage between vibrator relay terminal F inlet wire RW and chassis ground. Standard voltage : 12 V or more</p> <p>(2) When starter switch is ON and one of F-R lever vibration switches keep pressing, measure voltage between vibrator relay terminal H outlet wire G and chassis ground. Standard voltage : 12 V or more</p> <ul style="list-style-type: none"> • If above item (1) is OK and item (2) is NG, vibrator relay is faulty. 	Replace vibrator relay.
4. F-R Lever Vibration Switch	<p>(1) When starter switch is ON, measure voltage between F-R lever vibration switch terminal C inlet wire G and chassis ground. Standard voltage : 12 V or more</p> <p>(2) When starter switch is ON and one of F-R lever vibration switches keep pressing, measure voltage between F-R lever vibration switch terminal NO outlet wire B and chassis ground. Standard voltage : 12 V or more</p> <ul style="list-style-type: none"> • If above item (1) is OK and item (2) is NG, F-R lever vibration switch is faulty. 	Replace F-R lever vibration switch.
5. Harness Connecting Between Terminals	<ul style="list-style-type: none"> • Measure resistance of harness connecting between terminals. Standard resistance : 10 Ω or less • If resistance is abnormal, harness is faulty. 	Repair or replace harness.

TROUBLESHOOTING

Fig.: 2-5-1

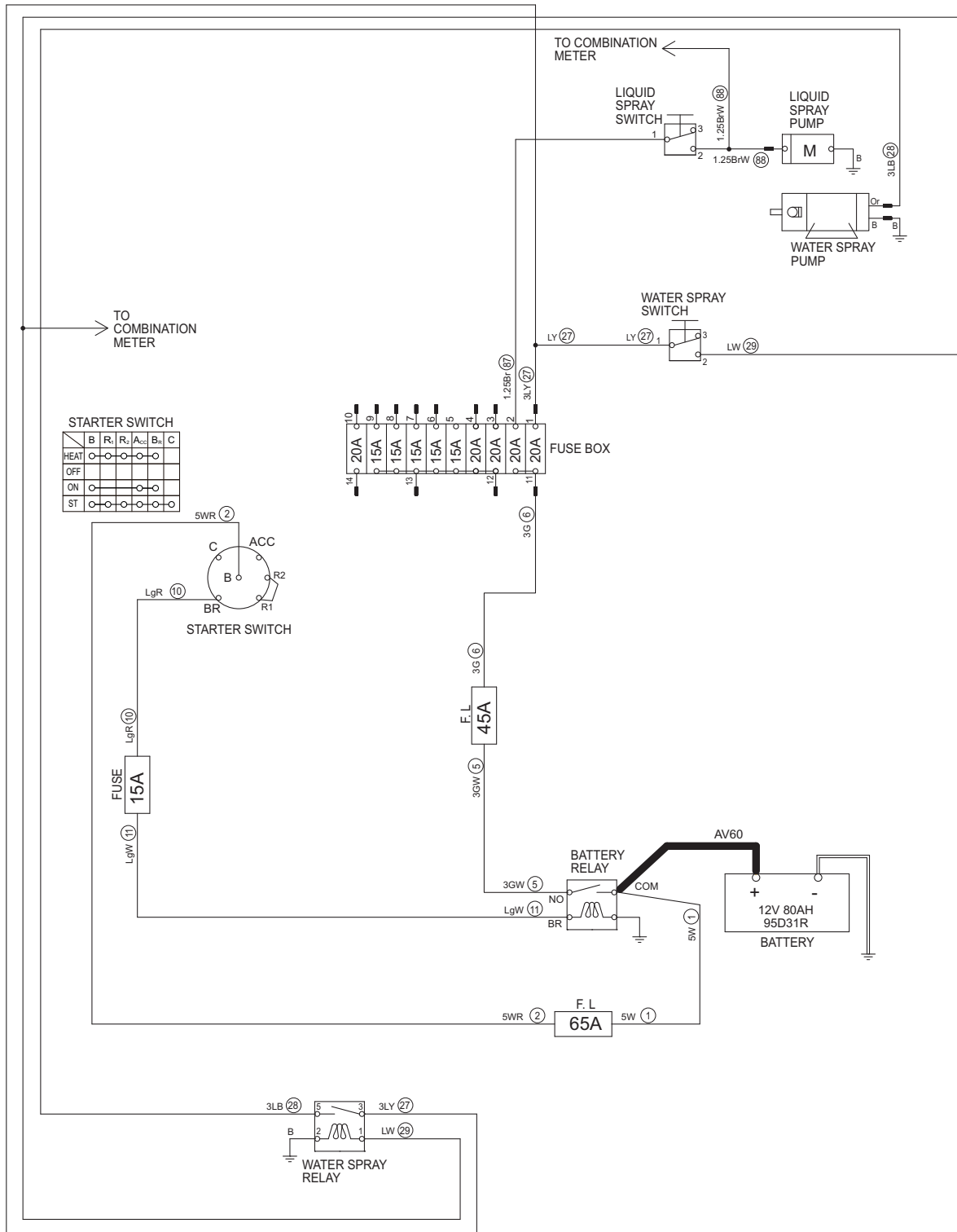

SW300-1-10004

2-5. Spray System

Check following item before troubleshooting.

- No blown fuse and power is applied up to fuses.
- Check any ground circuit which belongs to components to be checked.

2-5-1. Water spray does not operate

- Water spray switch must be ON.

Reference Fig.: 2-5-1

Check point	Check/Cause	Action
1. Water Spray Pump	(1) When starter switch is ON, measure voltage between water spray pump terminal inlet wire LB and chassis ground. Standard voltage: 12 V or more (2) Check that no abnormality is found in water spray pump ground terminal. • If above items (1) and (2) are OK and water spray pump does not operate, water spray pump is faulty.	Replace water spray pump.
2. Water Spray Relay	(1) When starter switch is ON, measure voltage between water spray relay terminal 1 inlet wire LW and chassis ground. Standard voltage: 12 V or more (2) When starter switch is ON, measure voltage between water spray relay terminal 3 inlet wire LY and chassis ground. Standard voltage: 12 V or more (3) When starter switch is ON, measure voltage between water spray relay terminal 5 outlet wire LB and chassis ground. Standard voltage: 12 V or more • If above items (1) and (2) are OK and item (3) is NG, water spray relay is faulty.	Replace water spray relay.
3. Water Spray Switch	(1) When starter switch is ON, measure voltage between water spray switch terminal 1 inlet wire LY and chassis ground. Standard voltage: 12 V or more (2) When starter switch is ON, measure voltage between water spray switch terminal 2 outlet wire LW and chassis ground. Standard voltage: 12 V or more • If above item (1) is OK and item (2) is NG, water spray switch is faulty.	Replace water spray switch.
4. Harness Connecting Between Terminals	• Measure resistance of harness connecting between terminals. Standard resistance: 10 Ω or less • If resistance is abnormal, harness is faulty.	Repair or replace harness.

TROUBLESHOOTING

Fig.: 2-5-1

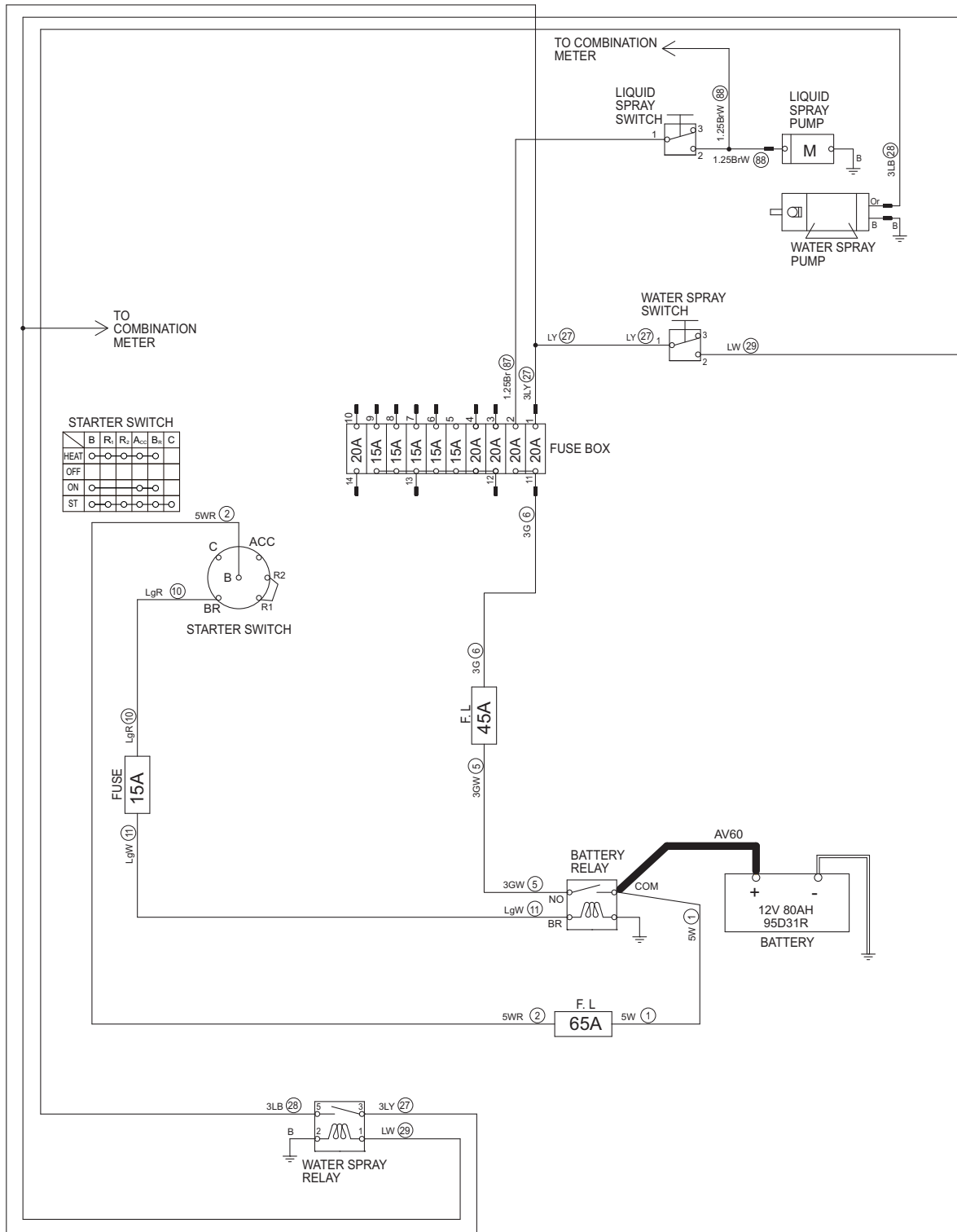

SW300-1-10004

2-5-2. Liquid spray does not operate (TW types)

- Liquid spray switch must be ON.

Reference Fig.: 2-5-1

Check point	Check/Cause	Action
1. Liquid Spray Pump	<p>(1) When starter switch is ON, measure voltage between liquid spray pump terminal inlet wire BrW and chassis ground. Standard voltage: 12 V or more</p> <p>(2) Check that no abnormality is found in liquid spray pump ground terminal.</p> <ul style="list-style-type: none"> • If above items (1) and (2) are OK and liquid spray pump does not operate, liquid spray pump is faulty. 	Replace liquid spray pump.
2. Liquid Spray Switch	<p>(1) When starter switch is ON, measure voltage between liquid spray switch terminal 1 inlet wire Br and chassis ground. Standard voltage: 12 V or more</p> <p>(2) When starter switch is ON, measure voltage between liquid spray switch terminal 2 outlet wire BrW and chassis ground. Standard voltage: 12 V or more</p> <ul style="list-style-type: none"> • If above item (1) is OK and item (2) is NG, liquid spray switch is faulty. 	Replace liquid spray switch.
3. Harness Connectin Between Terminals	<ul style="list-style-type: none"> • Measure resistance of harness connecting between terminals. Standard resistance : 10 Ω or less • If resistance is abnormal, harness is faulty. 	Repair or replace harness.

TROUBLESHOOTING

Fig.: 2-6-1

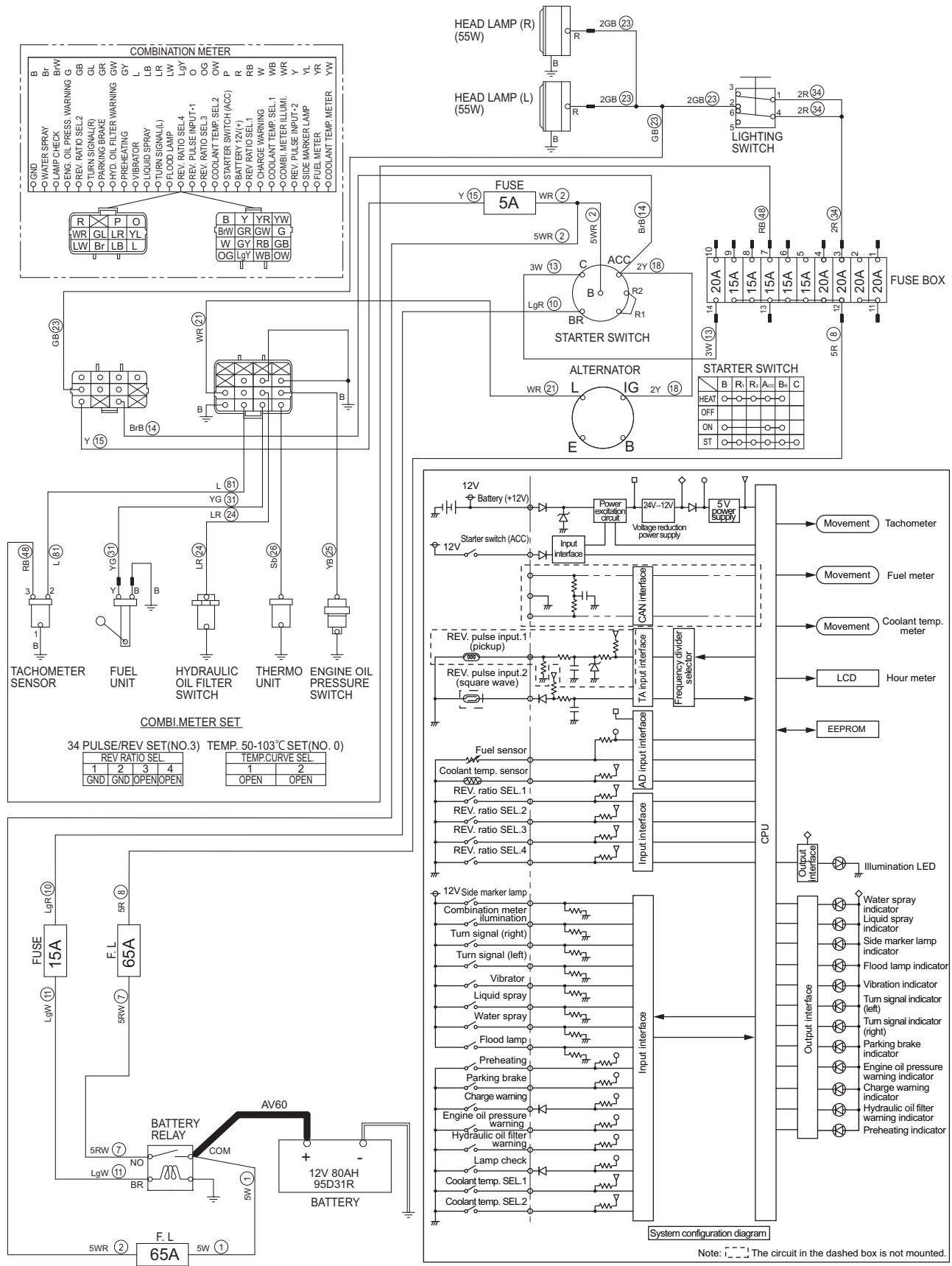

SW300-1-10008

2-6. Lighting

Check following items before troubleshooting.

- No blown fuse and power is applied up to fuses.
- Check any ground circuit which belongs to components to be checked.

2-6-1. Head lamp does not light

Reference Fig.: 2-6-1

Check point	Check/Cause	Action
1. Each Bulb	<ul style="list-style-type: none"> • Check that none of lamp bulbs is burned out or has a contact failure. • Bulb is faulty or poorly connected. 	Replace each bulb.
2. Lighting Switch	<p>(1) When starter switch is ON, measure voltage between lighting switch terminal 1 inlet wire R, terminal 4 inlet wire R and chassis ground. Standard voltage : 12 V or more</p> <p>(2) When starter switch is ON and lighting switch is ON, measure voltage between lighting switch terminal 2 outlet wire GB and chassis ground. Standard voltage : 12 V or more</p> <ul style="list-style-type: none"> • If above item (1) is OK and item (2) is NG, lighting switch is faulty. 	Replace lighting switch.
3. Harness Connecting Between Terminals	<ul style="list-style-type: none"> • Measure resistance of harness connecting between terminals. Standard resistance : 10 Ω or less • If resistance is abnormal, the harness is faulty. 	Repair or replace harness.

TROUBLESHOOTING

Fig.: 2-6-1

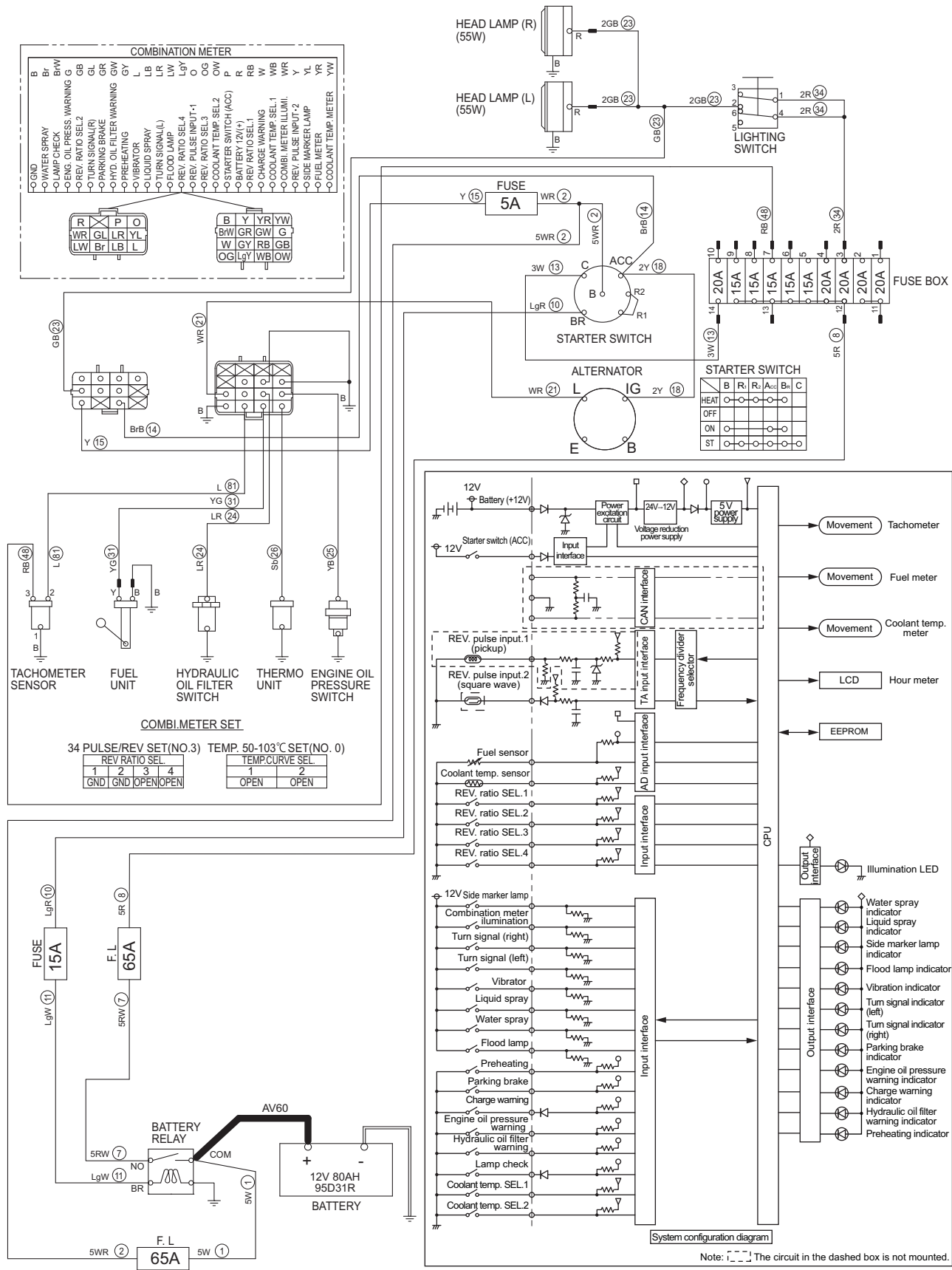

SW300-1-10008

2-6-2. Illumination of combination meter does not turn on

Reference Fig. : 2-6-1

Check point	Check/Cause	Action
1. Harness	<ul style="list-style-type: none"> Measure resistance between lighting switch terminal 2 wire GB and combination meter connector terminal wire No. 23 wire GB. Standard resistance : 10 Ω or less If resistance is abnormal, harness is faulty. 	Repair or replace harness.
2. Combination Meter (Combination meter illumination)	<p>(1) When starter switch is ON, measure voltage between combination meter terminal wires and ground terminal wire.</p> <ul style="list-style-type: none"> Battery terminal wire No. 15 inlet wire Y and ground terminal wire B Starter switch terminal wire No. 14 inlet wire BrB and ground terminal wire B <p>Standard voltage : 12 V or more</p> <p>(2) When starter switch is ON and lighting switch is ON, measure voltage between combination meter illumination terminal wire No.23 inlet wire GB and chassis ground. Standard voltage : 12 V or more</p> <ul style="list-style-type: none"> If above items (1) and (2) are OK and combination meter does not turn on, combination meter is faulty. 	Replace combination meter.

2-6-3. Combination meter warning lamp or indicator lamp is abnormal

Reference Fig. : 2-6-1

Check point	Check/Cause	Action
1. Harness	<ul style="list-style-type: none"> Measure resistance between alternator terminal L wire WR and combination meter connection terminal wire No. 21 wire WR. Standard resistance : 10 Ω or less If resistance is abnormal, harness is faulty. 	Repair or replace harness.
2. Combination Meter (Lamp check)	<p>(1) When starter switch is ON, measure voltage between combination meter terminal wires and ground terminal wire.</p> <ul style="list-style-type: none"> Battery terminal wire No. 15 inlet wire Y and ground terminal wire B Starter switch terminal wire No. 14 inlet wire BrB and ground terminal wire B <p>Standard voltage : 12 V or more</p> <p>(2) When starter switch is ON, check that parking brake indicator lamp, hydraulic oil filter warning lamp, engine oil pressure warning lamp and charge warning lamp illuminate and then go out after starting engine.</p> <ul style="list-style-type: none"> If above item (1) is OK and item (2) is NG, combination meter is faulty. 	Replace combination meter.

2-6-4. Tachometer reading is abnormal

Reference Fig. : 2-6-1

Check point	Check/Cause	Action
1. Combination Meter (Tachometer)	<p>(1) When starter switch is ON, measure voltage between combination meter terminal wires and ground terminal wire.</p> <ul style="list-style-type: none"> • Battery terminal wire No. 15 inlet wire Y and ground terminal wire B • Starter switch terminal wire No. 14 inlet wire BrB and ground terminal wire B <p>Standard voltage : 12 V or more</p> <p>(2) Check that combination meter terminal B wires (rev. ratio 1 and 2) are grounded.</p> <p>(3) Start engine and measure pulse between combination meter rev. pulse input. 2 terminal wire No. 81 inlet wire L and chassis ground.</p> <p>Standard pulse : 34 pulses/rotation of engine</p> <ul style="list-style-type: none"> • If above items (1) and (2) are OK and pulse is NG in item (3), tachometer sensor is faulty. • If above items (1) and (2) are OK and tachometer reading is NG in item (3), combination meter is faulty. 	Replace tachometer sensor or combination meter.
2. Harness Connecting Between Terminals	<ul style="list-style-type: none"> • Measure resistance of harness connecting between terminals. <p>Standard resistance : 10 Ω or less</p> <ul style="list-style-type: none"> • If resistance is abnormal, harness is faulty. 	Repair or replace harness.

2-6-5. Hour meter is abnormal

Reference Fig. : 2-6-1

Check point	Check/Cause	Action
1. Combination Meter (Hour meter)	<ul style="list-style-type: none"> • When starter switch is ON, measure voltage between combination meter terminal wires and ground terminal wire. • Battery terminal wire No. 15 inlet wire Y and ground terminal wire B • Starter switch terminal wire No. 14 inlet wire BrB and ground terminal wire B <p>Standard voltage : 12 V or more</p> <ul style="list-style-type: none"> • If no abnormality is found, combination meter is faulty. 	Replace combination meter.

TROUBLESHOOTING

Fig.: 2-6-1

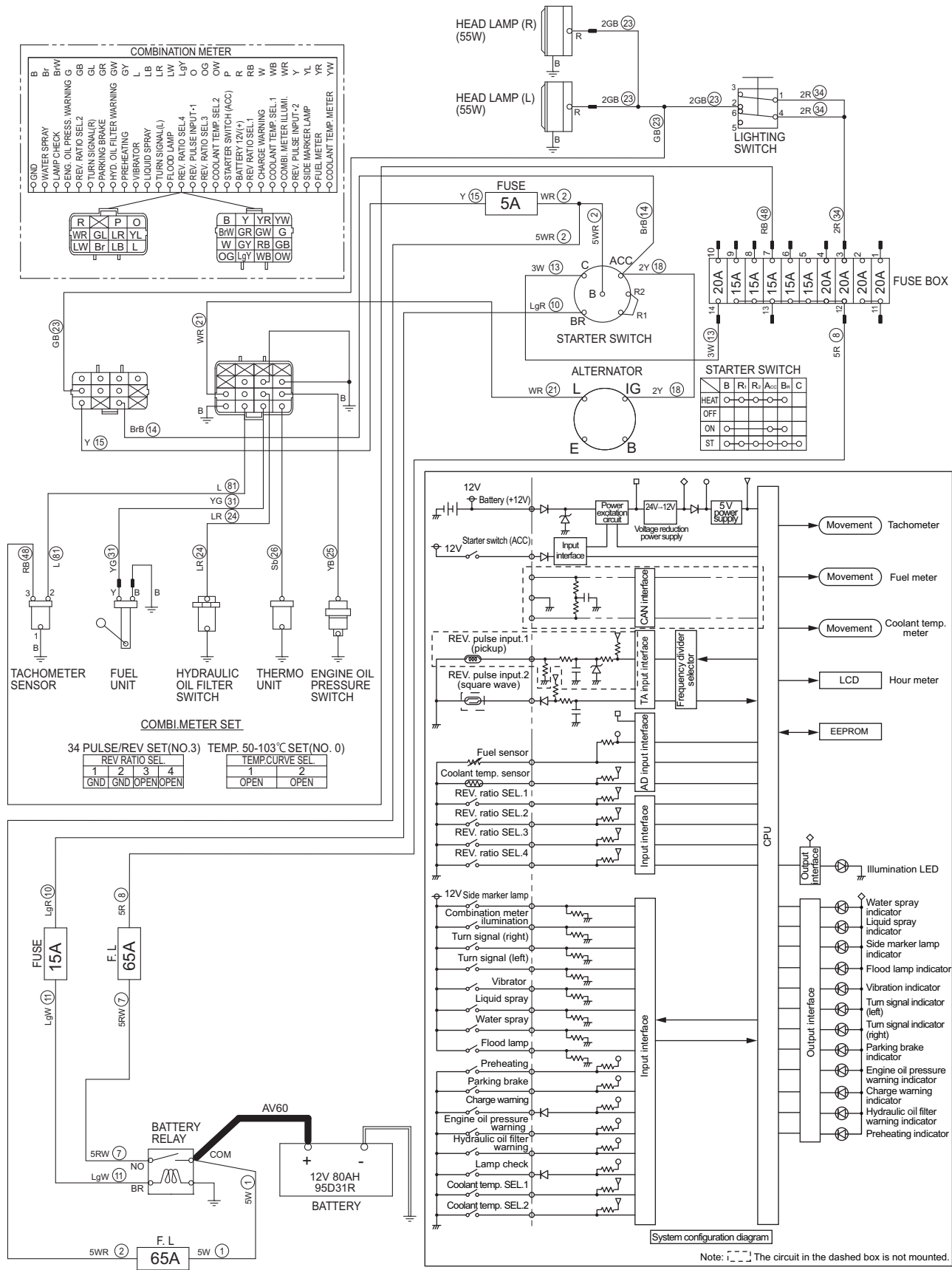

SW300-1-10008

2-6-6. Temperature meter is abnormal

Reference Fig. : 2-6-1

Check point	Check/Cause	Action
1. Thermo Unit	<ul style="list-style-type: none"> • Disconnect harness and measure resistance of thermo unit. Standard resistance : 164.6 Ω [(at unit temperature of 50°C (122°F)) 26.44 Ω [(at unit temperature of 103°C (217°F)) • If resistance is abnormal, thermo unit is faulty. 	Replace thermo unit.
2. Combination Meter (Temperature meter)	<ul style="list-style-type: none"> • When starter switch is ON, measure voltage between combination meter terminal wires and ground terminal wire. <ul style="list-style-type: none"> • Battery terminal wire No. 15 inlet wire Y and ground terminal wire B • Starter switch terminal wire No. 14 inlet wire BrB and ground terminal wire B Standard voltage : 12 V or more • If no abnormality is found, combination meter is faulty. 	Replace combination meter.
3. Harness Connecting Between Terminals	<ul style="list-style-type: none"> • Measure resistance of harness connecting between terminals. Standard resistance : 10 Ω or less • If resistance is abnormal, harness is faulty. 	Repair or replace harness.

2-6-7. Fuel meter is abnormal

Reference Fig. : 2-6-1

Check point	Check/Cause	Action
1. Fuel Unit	<ul style="list-style-type: none"> • Disconnect harness and measure resistance of fuel unit. Standard resistance : 13.5 Ω (with float in "F") 80.0 Ω (with float in "E") • If resistance is abnormal, fuel unit is faulty. 	Replace fuel unit.
2. Combination Meter (Fuel meter)	<ul style="list-style-type: none"> • When starter switch is ON, measure voltage between combination meter terminal wires and ground terminal wire. <ul style="list-style-type: none"> • Battery terminal wire No. 15 inlet wire Y and ground terminal wire B • Starter switch terminal wire No. 14 inlet wire BrB and ground terminal wire B Standard voltage : 12 V or more • If no abnormality is found, combination meter is faulty. 	Replace combination meter.
3. Harness Connecting Between Terminals	<ul style="list-style-type: none"> • Measure resistance of harness connecting between terminals. Standard resistance : 10 Ω or less • If resistance is abnormal, harness is faulty. 	Repair or replace harness.

TROUBLESHOOTING

Fig.: 2-6-1

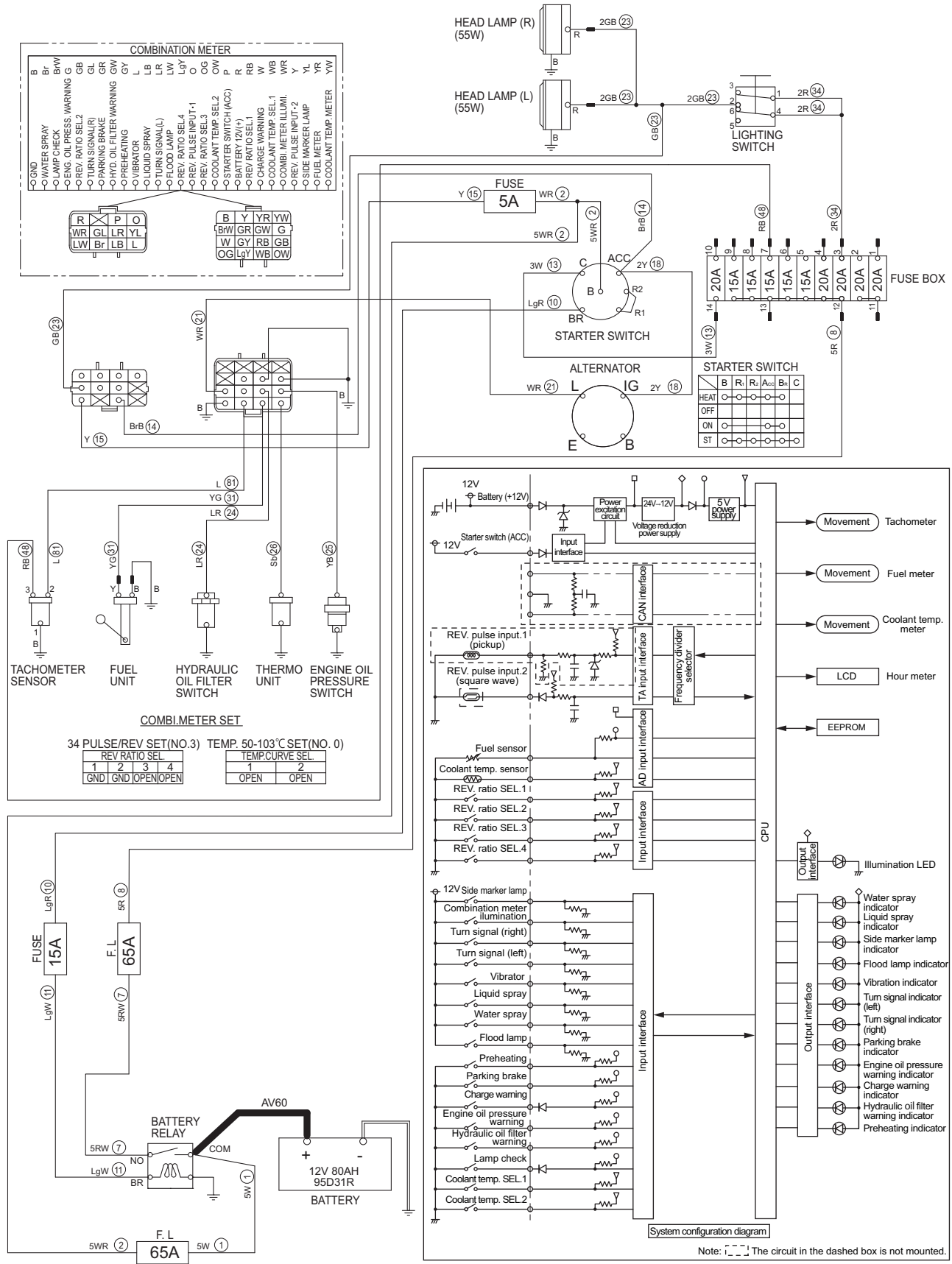

SW300-1-10008

2-6-8. Hydraulic oil filter warning lamp remains ON

Reference Fig. : 2-6-1

Check point	Check/Cause	Action
1. Hydraulic Oil Filter Switch	<ul style="list-style-type: none"> • When starter switch is OFF, check continuity between hydraulic oil filter switch inlet terminal wire LR and chassis ground. There is no continuity in normal condition. • If there is continuity, hydraulic filter switch is faulty. 	Replace hydraulic oil filter switch.

2-6-9. Engine oil pressure warning lamp remains ON

Reference Fig. : 2-6-1

Check point	Check/Cause	Action
1. Harness	<ul style="list-style-type: none"> • Disconnect connectors between combination meter and engine oil pressure switch. • Measure resistance between terminals and chassis ground. <ul style="list-style-type: none"> • Combination meter connector terminal wire No.25 wire and chassis ground. • Engine oil pressure switch terminal wire YB and chassis ground. Standard resistance : 100 kΩ or more • If resistance is abnormal, harness is faulty. 	Repair or replace harness.
2. Engine Oil Pressure Switch	<ul style="list-style-type: none"> • Disconnect engine oil pressure switch and check continuity between its terminals. There is continuity in normal condition. • If there is continuity, engine oil pressure switch is faulty. 	Replace engine oil pressure switch.
3. Combination Meter (Engine oil pressure warning indicator lamp)	<p>(1) When starter switch is ON, measure voltage between combination meter terminal wires and ground terminal wire.</p> <ul style="list-style-type: none"> • Battery terminal inlet wire No. 15 inlet wire Y and ground terminal wire B. • Starter switch terminal inlet wire No. 14 inlet wire BrB and ground terminal wire B. Standard voltage : 12 V or more <p>(2) When starter switch is ON, measure voltage between combination meter engine oil pressure warning terminal outlet wire No. 25 wire YB and chassis ground. Standard voltage : 12 V or more</p> <ul style="list-style-type: none"> • If above items (1) and (2) are OK and no abnormality is found in engine oil pressure switch but engine oil pressure warning lamp remains on after starting engine, combination meter is faulty. 	Replace combination meter.

TROUBLESHOOTING

Fig.: 2-6-2

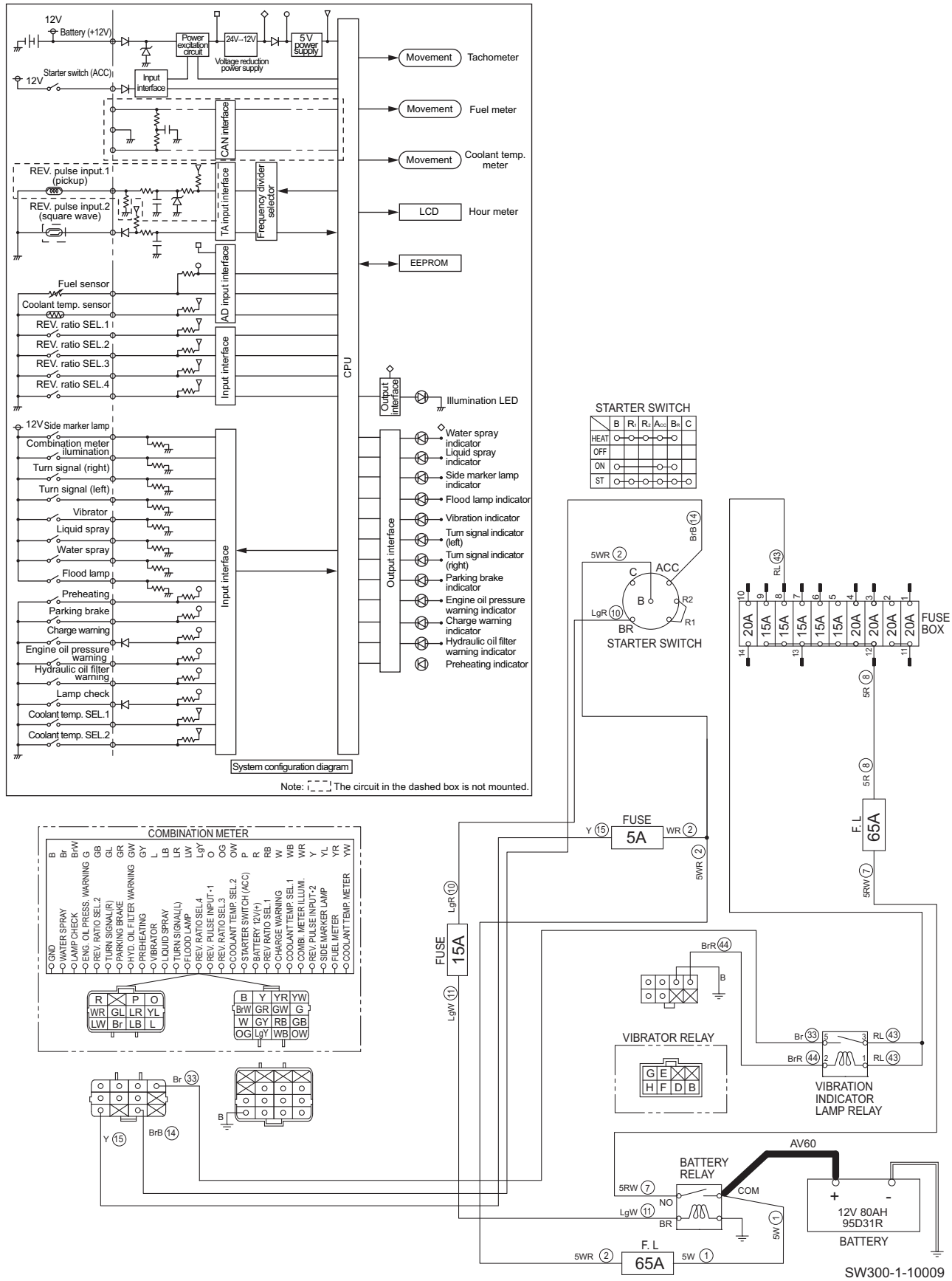

2-6-10. Vibration indicator lamp does not light

- Check that vibrator can be operated.

Reference Fig. : 2-6-2

Check point	Check/Cause	Action
1. Harness	<ul style="list-style-type: none"> • Measure resistance between vibrator indicator lamp relay terminal 5 wire Br and combination meter connector terminal wire No.33 wire Br. Standard resistance: 10 Ω or less • If above item is NG, harness is faulty. 	Repair or replace harness.
2. Vibration Indicator Lamp Relay	<p>(1) When starter switch is ON, measure voltage between vibration indicator lamp relay terminal 1 and 3 inlet wires RL and chassis ground. Standard voltage : 12 V or more</p> <p>(2) When starter switch is ON, measure voltage between vibration indicator lamp relay terminal 5 outlet wire Br and chassis ground. Standard voltage : 12 V or more</p> <ul style="list-style-type: none"> • If above item (1) is OK and item (2) is NG, vibration indicator lamp relay is faulty. 	Replace vibration indicator lamp relay.
3. Combination Meter (Vibration indicator lamp)	<p>(1) When starter switch is ON, measure voltage between combination meter terminal wires and ground terminal wire.</p> <ul style="list-style-type: none"> • Battery terminal wire No. 15 inlet wire Y and ground terminal wire B • Starter switch terminal wire No. 14 inlet wire BrB and ground terminal wire B <p>Standard voltage : 12 V or more</p> <p>(2) When starter switch is ON, measure voltage between combination meter vibration indicator lamp terminal wire No. 33 inlet wire Br and chassis ground. Standard voltage : 12 V or more</p> <ul style="list-style-type: none"> • If above items (1) and (2) are OK and vibrator indicator lamp does not light, combination meter is faulty. 	Replace combination meter.

TROUBLESHOOTING

Fig.: 2-6-3

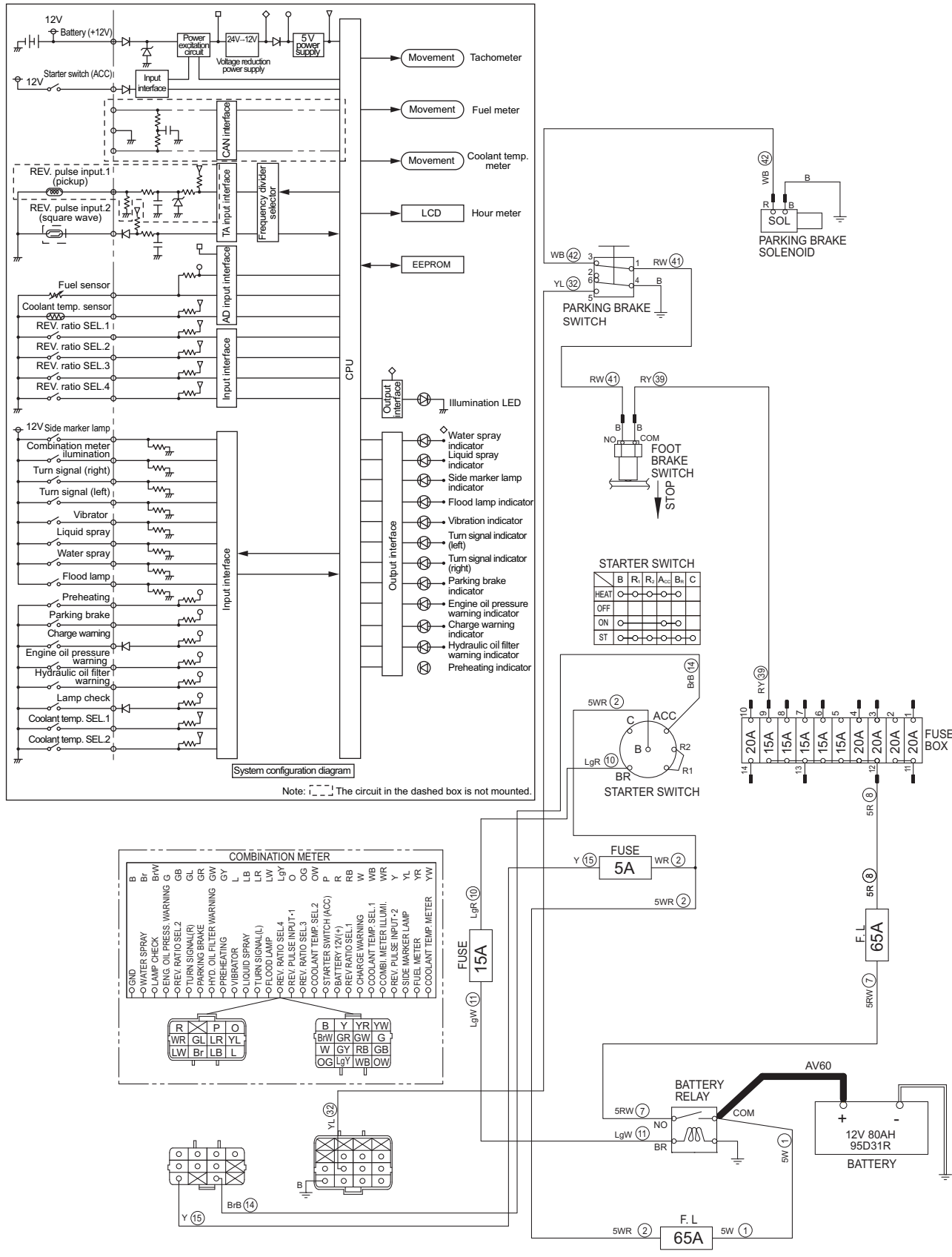

SW300-1-10011

2-6-11. Parking brake indicator lamp does not light

Reference Fig. : 2-6-3

Check point	Check/Cause	Action
1. Harness	<ul style="list-style-type: none"> • Measure resistance between parking brake switch terminal 5 wire YL and combination meter connector terminal wire No. 32 wire YL. Standard resistance : 10 Ω or less • If resistance is abnormal, harness is faulty. 	Repair or replace harness.
2. Parking Brake Switch	<ul style="list-style-type: none"> • When parking brake is applied, check continuity between parking brake switch terminal 4 and 5. There is continuity in normal condition. • If there is no continuity, parking brake switch is faulty. 	Replace parking brake switch.
3. Combination Meter (Parking brake indicator lamp)	<p>(1) When starter switch is ON, measure voltage between combination meter terminal wires and ground terminal wire.</p> <ul style="list-style-type: none"> • Battery terminal wire No. 15 inlet wire Y and ground terminal wire B • Starter switch terminal wire No. 14 inlet wire BrB and ground terminal wire B <p>Standard voltage : 12 V or more</p> <p>(2) When starter switch is ON and parking brake switch is applied, measure voltage between combination meter parking brake terminal wire No. 32 outlet wire YL and chassis ground.</p> <p>Standard voltage : 12 V or more</p> <ul style="list-style-type: none"> • If above items (1) and (2) are OK and parking brake indicator lamp does not light, combination meter is faulty. 	Replace combination meter.

TROUBLESHOOTING

Fig.: 2-6-4

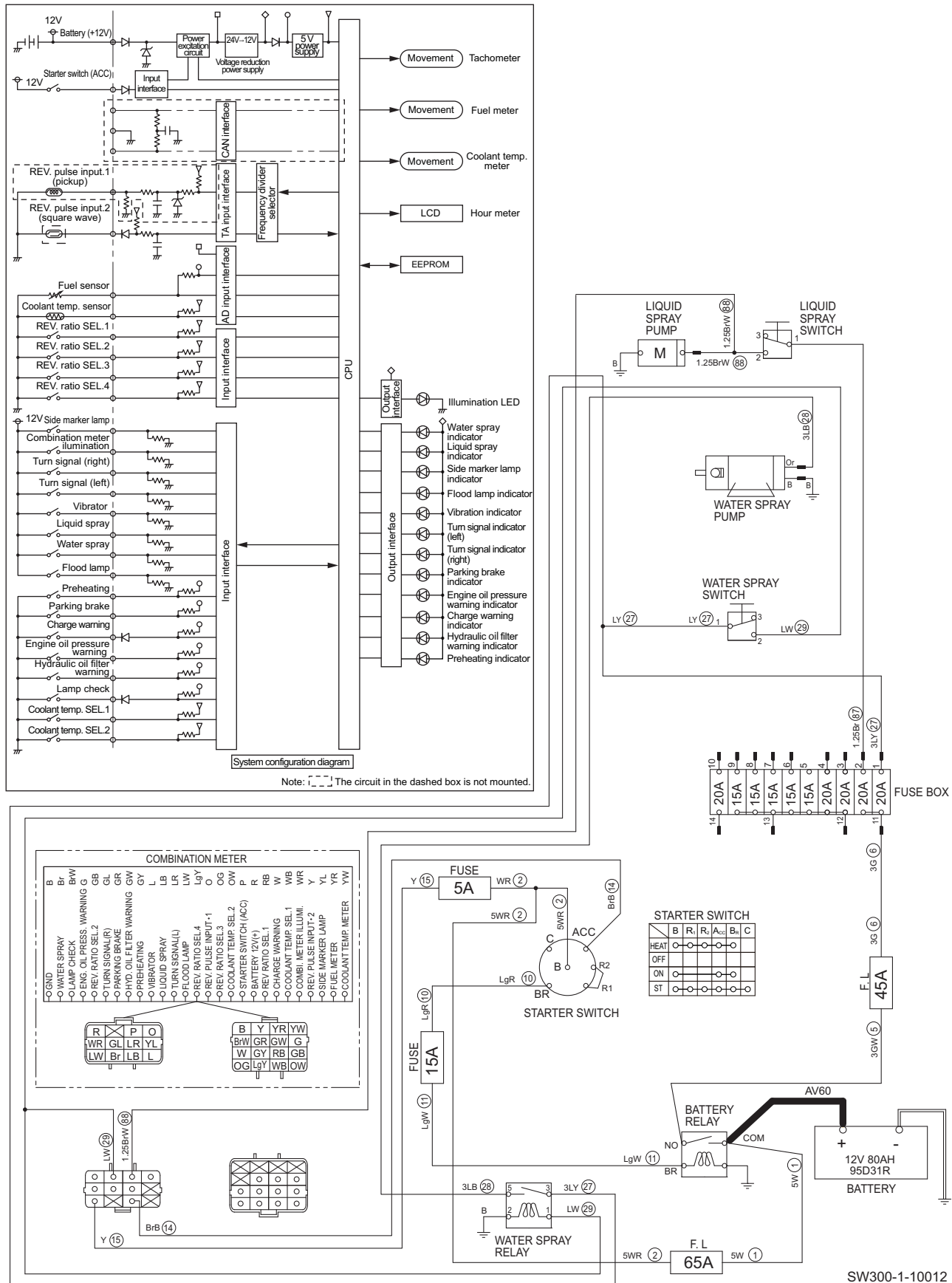

2-6-12. Water spray indicator lamp does not light

- Check that water spray pump can be activated.

Reference Fig. : 2-6-4

Check point	Check/Cause	Action
1. Harness	<ul style="list-style-type: none"> • Measure resistance between water spray switch terminal 2 wire LW and combination meter connector terminal wire No. 29 wire LW. Standard resistance : 10 Ω or less • If resistance is NG, harness is faulty. 	Repair or replace harness.
2. Combination Meter (Water spray indicator lamp)	<p>(1) When starter switch is ON, measure voltage between combination meter terminal wires and ground terminal wire.</p> <ul style="list-style-type: none"> • Battery terminal wire No. 15 inlet wire Y and ground terminal wire B. • Starter switch terminal wire No. 14 inlet wire BrB and ground terminal wire B. <p>Standard voltage : 12 V or more</p> <p>(2) When starter switch is ON and water spray switch is ON, measure voltage between combination meter water spray terminal wire No. 29 inlet wire LW and chassis ground.</p> <p>Standard voltage : 12 V or more</p> <ul style="list-style-type: none"> • If above items (1) and (2) are OK and water spray indicator lamp does not light, combination meter is faulty. 	Replace combination meter.

2-6-13. Liquid spray indicator lamp does not light (TW types)

- Check that liquid spray pump can be activated.

Reference Fig. : 2-6-4

Check point	Check/Cause	Action
1. Harness	<ul style="list-style-type: none"> • Measure resistance between liquid spray switch terminal 2 wire BrW and combination meter connector terminal wire No. 88 wire BrW. Standard resistance : 10 Ω or less • If resistance is NG, harness is faulty. 	Repair or replace harness.
2. Combination Meter (Liquid spray indicator lamp)	<p>(1) When starter switch is ON, measure voltage between combination meter terminal wires and ground terminal wire.</p> <ul style="list-style-type: none"> • Battery terminal wire No. 15 inlet wire Y and ground terminal wire B. • Starter switch terminal wire No. 14 inlet wire BrB and ground terminal wire B. <p>Standard voltage : 12 V or more</p> <p>(2) When starter switch is ON and liquid spray switch is ON, measure voltage between combination meter liquid spray terminal wire No. 88 inlet wire BrW and chassis ground.</p> <p>Standard voltage : 12 V or more</p> <ul style="list-style-type: none"> • If above items (1) and (2) are OK and liquid spray indicator lamp does not light, combination meter is faulty. 	Replace combination meter.

TROUBLESHOOTING

Fig.: 2-6-5

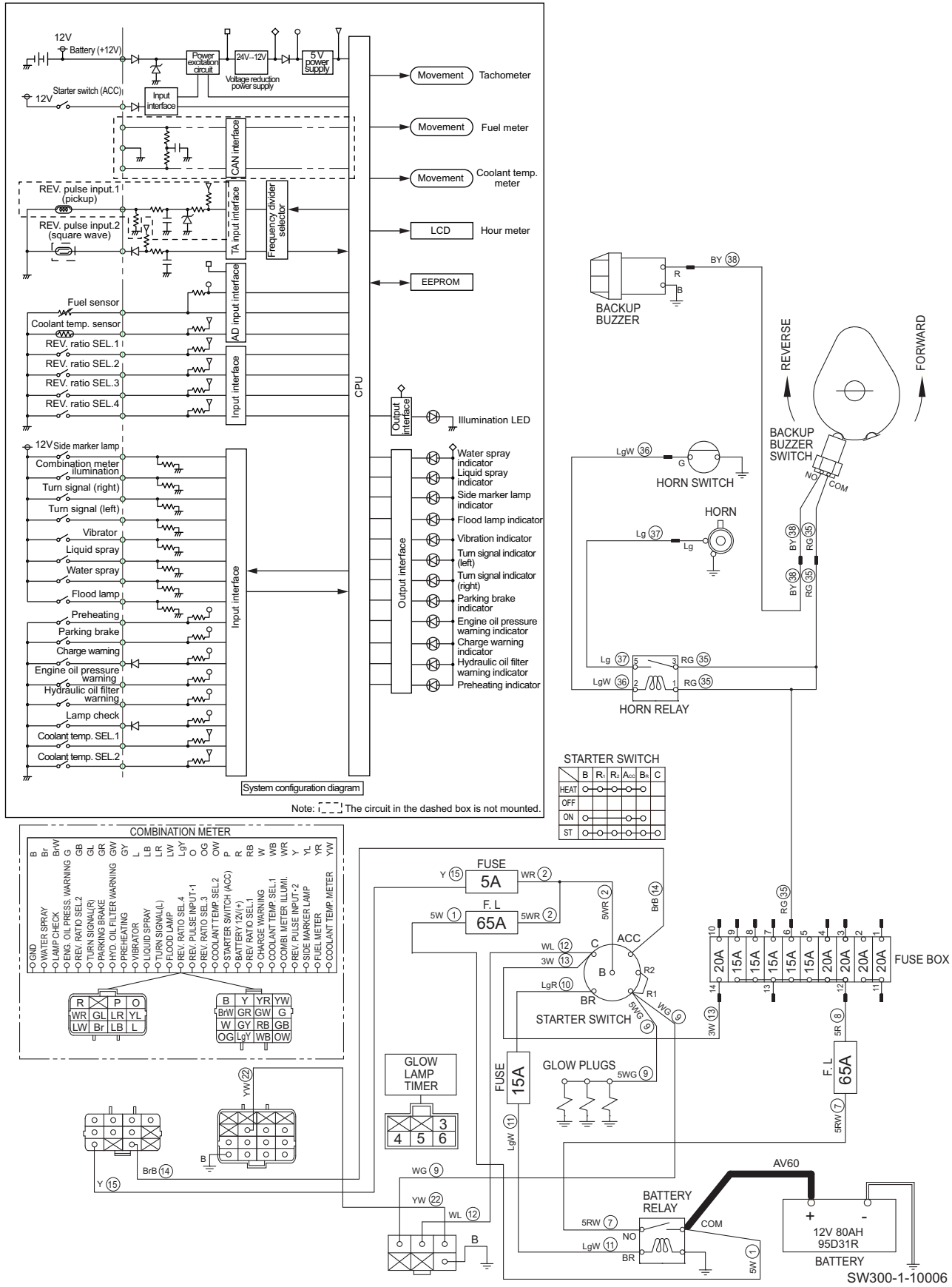

2-6-14. Preheating indicator lamp does not light

Reference Fig. : 2-6-5

Check point	Check/Cause	Action
1. Harness	<p>(1) Measure resistance between glow lamp timer terminal 6 wire YW and combination meter connector terminal wire No. 22 wire YW. Standard resistance : 10 Ω or less</p> <p>(2) Measure resistance between glow plug timer terminal 4 wire WG and starter switch terminal R1 wire WG. Standard resistance : 10 Ω or less</p> <p>(3) Measure resistance between glow lamp timer terminal 5 wire WL and starter switch terminal C wire WL. Standard resistance : 10 Ω or less</p> <ul style="list-style-type: none"> • If item (1), (2) or (3) is NG, harness is faulty. 	Repair or replace harness.
2. Glow Lamp Timer	<p>(1) When starter switch is HEAT, measure voltage between glow lamp timer terminal 4 inlet wire WG and chassis ground. Standard voltage : 12 V or more</p> <p>(2) When starter switch is START, measure voltage between glow lamp timer terminals and chassis ground.</p> <ul style="list-style-type: none"> • Terminal 4 inlet wire WG and chassis ground. • Terminal 5 inlet wire WL and chassis ground. <p>Standard voltage : 12 V or more</p> <p>(3) When starter switch is HEAT, measure voltage between glow lamp timer terminal 6 inlet wire YW and chassis ground. Standard voltage : 12 V or more (Electricity flows for a definite time)</p> <ul style="list-style-type: none"> • If above items (1) and (2) are OK and item (3) is NG, glow lamp timer is faulty. 	Replace glow lamp timer.
3. Combination Meter (Preheating indicator lamp)	<p>(1) When starter switch is ON, measure voltage between combination meter terminal wires and ground terminal wire.</p> <ul style="list-style-type: none"> • Battery terminal wire No.15 inlet wire Y and ground terminal wire B • Starter switch terminal wire No. 14 inlet wire BrB and ground terminal wire B <p>Standard voltage : 12 V or more</p> <p>(2) When starter switch is HEAT, measure voltage between combination meter preheating terminal wire No. 22 outlet wire YW and ground terminal wire B. Standard voltage : 12 V or more (for a certain period)</p> <ul style="list-style-type: none"> • If above items (1) and (2) are OK and glow indicator lamp does not light, combination meter is faulty. 	Replace combination meter.

TROUBLESHOOTING

Fig.: 2-6-5

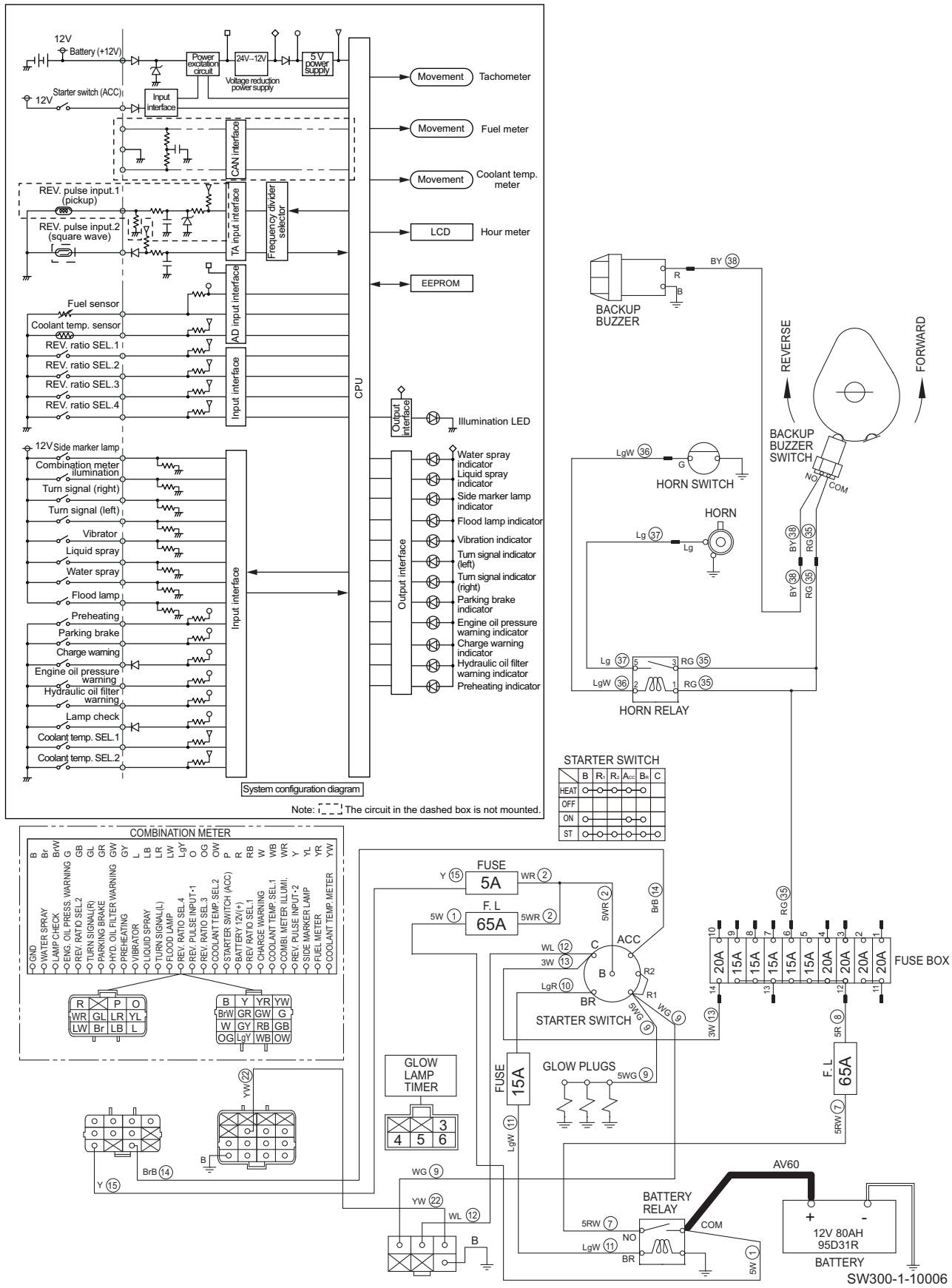

2-6-15 Horn does not sound

Reference Fig. : 2-6-5

Check point	Check/Cause	Action
1. Horn	<ul style="list-style-type: none"> Disconnect horn and directly connect battery positive terminal to horn terminal wire Lg side and negative terminal to horn terminal wire B side. If horn does not sound, horn is faulty. 	Replace horn.
2. Horn Relay	<p>(1) When starter switch is ON and horn switch is pressed, measure voltage between horn relay terminal 2 outlet wire LgW and chassis ground. Standard voltage : 12 V or more</p> <p>(2) When starter switch is ON and horn switch is pressed, measure voltage between horn relay terminal 5 outlet wire Lg and chassis ground. Standard voltage : 12 V or more</p> <ul style="list-style-type: none"> If above item (1) is OK and item (2) is NG, horn relay is faulty. 	Replace horn relay.
3. Horn Switch	<ul style="list-style-type: none"> When horn switch is not pressed, measure resistance between horn switch terminals. Standard resistance : 100 kΩ or more If resistance is abnormal, horn switch is faulty. 	Replace horn switch.
4. Harness Connecting Between Terminals	<ul style="list-style-type: none"> Measure resistance of harness connecting between terminals. Standard resistance : 10 Ω or less If resistance is abnormal, harness is faulty. 	Repair or replace harness.

2-6-16. Backup buzzer does not sound

Reference Fig. : 2-6-5

Check point	Check/Cause	Action
1. Backup Buzzer	<ul style="list-style-type: none"> Disconnect backup buzzer and directly connect battery positive terminal to backup buzzer terminal wire BY side and negative terminal to backup buzzer terminal wire B side. If backup buzzer does not sound, backup buzzer is faulty. 	Replace backup buzzer.
2. Backup Buzzer Switch	<p>(1) When starter switch is ON, measure voltage between backup buzzer switch terminal COM inlet wire RG and chassis ground. Standard voltage : 12 V or more</p> <p>(2) When starter switch is ON and F-R lever is in "R", measure voltage between backup buzzer switch terminal NO outlet wire BY and chassis ground. Standard voltage : 12 V or more</p> <ul style="list-style-type: none"> If above item (1) is OK and item (2) is NG, backup buzzer switch is faulty. 	Replace backup buzzer switch.
3. Harness Connecting Between Terminals	<ul style="list-style-type: none"> Measure resistance of harness connecting between terminals. Standard resistance : 10 Ω or less If resistance is abnormal, harness is faulty. 	Repair or replace harness.

3. HYDRAULIC SYSTEM TROUBLESHOOTING

3-1. When Performing Hydraulic System Troubleshooting

- The largest factor in the majority of failures of hydraulic devices operating under conditions of higher pressure and greater precision is the entry of dirt (foreign substances) into the hydraulic circuit. Particular caution is required when supplying hydraulic oil or when disassembling and assembling hydraulic devices.

1) Pay attention to the work environment.

As much as possible, avoid performing tasks such as supplying hydraulic oil, replacing filters and repair work on rainy days, when there is strong wind, or in locations where there is much dust.

2) Disassembly and maintenance work in the field

There is the danger of dust entry when disassembly and maintenance work for hydraulic components is performed in the field. In addition, because performance verification after repairs are completed is difficult, replacement of the entire assembly is preferred. Perform disassembly and maintenance of hydraulic components in a special room protected from dust, and use special testers to verify the performance.

3) Sealing of openings

Use caps, tape, plastic bags or other means to seal the openings of removed pipes and components in order to prevent foreign substances from entering. Never leave the openings exposed or put a shop cloth into them. There is the danger of foreign substances entering or of leaking oil causing environmental contamination.

Do not dispose of waste oil on-site. Either deliver it to the customer and request disposal or take it back with you and dispose of it.

4) Prevent entry of foreign substances when supplying oil.

Take care that foreign substances do not enter when supplying hydraulic oil. Clean the oil supply port and the area around it, as well as the supply pump, oilcan and other items. A more reliable method is to use oil cleaning equipment, which can filter out the contamination that occurred during storage.

5) Change hydraulic oil while the temperature is still high.

All oils, including hydraulic oil, flow more readily when they are warm. Higher temperatures also make it easier to eject the sludge and other substances outside the circuit together with the oil. For these reasons, oil changes should be performed while the oil temperature is high. When changing the oil, it is necessary to drain out as much of the old hydraulic oil as possible. (In addition to the hydraulic oil tank, also drain the oil from the filter and circuit drain plugs.) If old hydraulic oil remains in the system, the contaminants and sludge in the old oil will mix with the new oil and shorten the hydraulic oil lifetime.

3-2. Propulsion System

If a problem occurs in the propulsion systems such as the propulsion pump, propulsion motor and brakes, determine the cause and carry out action as required, according to the following general troubleshooting items.

(NOTICE)

- When checking whether or not the pressure is correct, refer to the pressure standard value for each hydraulic circuit.

3-2-1. Machine moves neither forward nor backward 1/2

Check point	Cause	Check/Action
1. Oil Level of Hydraulic Oil Tank	Oil level in hydraulic oil tank is low.	Fill tank until correct oil level is obtained.
2. Bypass Valve	Bypass valve is open.	Inspect high pressure relief and bypass valves or replace them if necessary.
3. F-R Lever Linkage	F-R lever linkage is faulty.	Check and adjust F-R lever linkage or replace it if necessary.
4. Charge Circuit Pressure	Propulsion pump does not discharge oil because charge pressure is low.	<ul style="list-style-type: none"> • Measure charge pressure. • If low, check and adjust charge relief valve or replace it if necessary.
	Insufficient charge pump discharge.	Repair charge pump or replace it if necessary.
	Charge pressure decreases due to internal leakage of solenoid valve connecting oil supply circuit with charge circuit. • Parking brake solenoid valve	<ul style="list-style-type: none"> • When solenoid is energized, check if oil flows in return circuit to tank. • If oil is flowing, repair solenoid valve or replace it if necessary.
5. Suction Filter for Charge Pump	Charge pump flow is reduced due to clogged filter.	Clean suction filter or replace it if necessary.
6. Propulsion Circuit Pressure	Circuit does not obtain required pressure because setting pressure of high pressure relief is low.	<ul style="list-style-type: none"> • Measure propulsion circuit pressure. • If low, inspect high pressure relief valve or replace it if necessary.
7. Propulsion Motor	Propulsion circuit pressure is not held in propulsion motor case.	If pressure in propulsion motor case is not within allowable range, repair propulsion motor or replace it if necessary.
	Internal leakage of propulsion motor.	<ul style="list-style-type: none"> • Measure drain quantity from propulsion motor. • If drain quantity is larger than standard value, repair propulsion motor or replace it if necessary.
	Sticking of disc brakes causes brakes to remain applied.	<ul style="list-style-type: none"> • Replace disc brakes.

TROUBLESHOOTING

3-2-1. Machine moves neither forward nor backward 2/2

Check point	Cause	Check/Action
8. Propulsion Pump	Discharge flow rate is insufficient due to efficiency degradation of propulsion pump.	<ul style="list-style-type: none"> • Measure discharge flow rate of propulsion pump with flow meter. • If discharge flow rate is not within specified range, repair propulsion pump or replace it if necessary.
	Discharge flow rate is insufficient due to wear of propulsion pump drive shaft splines.	Replace propulsion pump.
	Propulsion circuit pressure is not held in propulsion pump case.	If pressure in propulsion pump case is not within allowable range, repair propulsion pump or replace it if necessary.
9. Parking Brake Solenoid Valve	Brake remains applied because spool of parking brake solenoid valve does not shift.	Repair parking brake solenoid valve or replace it if necessary.
10. Brake Inlet Pressure	Brake cannot be released because brake inlet pressure is low.	<ul style="list-style-type: none"> • Measure brake release pressure. • If low, repair or replace propulsion motor.
11. Coupling	Drive torque is not transmitted to pump due to faulty coupling.	Replace coupling.

3-2-2. Machine moves in one direction only (forward or backward)

Check point	Cause	Check/Action
1. F-R Lever Linkage	F-R lever linkage is faulty.	Check and adjust F-R lever linkage or replace it if necessary.
2. High Pressure Relief Valve	Low circuit pressure due to incorrect high pressure relief setting or internal leakage of high pressure relief valve.	<ul style="list-style-type: none"> • Interchange two high pressure relief valves. • If faulty condition is accordingly reversed, inspect high pressure relief valve or replace it if necessary.

3-2-3. Slow machine speed or small drive force 1/2

Check point	Cause	Check/Action
1. F-R Lever Linkage	F-R lever linkage is faulty.	Check and adjust F-R lever linkage or replace it if necessary.
2. Bypass Valve	Bypass valve is slightly open.	Inspect high pressure relief and bypass valves or replace them if necessary.
3. Charge Circuit Pressure	Stroke of propulsion pump swash plate is small because charge pressure is low, decreasing discharge rate of propulsion pump.	<ul style="list-style-type: none"> • Measure charge pressure. • If low, check and adjust charge relief valve or replace it if necessary.
	Insufficient charge pump discharge.	Repair charge pump or replace it if necessary.
	Charge pressure decreases due to internal leakage of solenoid valve connecting oil supply circuit with charge circuit. <ul style="list-style-type: none"> • Parking brake solenoid valve 	<ul style="list-style-type: none"> • When solenoid is energized, check if oil flows in return circuit to tank. • If oil is flowing, repair solenoid valve or replace it if necessary.
4. Suction Filter for Charge Pump	Flow rate of charge pump decreases as well as charge pressure decreases due to clogged filter.	Clean suction filter or replace it if necessary.

3-2-3. Slow machine speed or small drive force 2/2

Check point	Cause	Check/Action
5. Propulsion Motor	Propulsion motor inlet pressure is low.	<ul style="list-style-type: none"> • Measure propulsion motor inlet pressure. • If low, inspect high pressure relief valve or replace it if necessary.
	Propulsion circuit pressure is not held in propulsion motor case.	If pressure in propulsion motor case is not within allowable range, repair propulsion motor or replace it if necessary.
	Output of propulsion motor decreases and number of revolutions decreases due to internal leakage of propulsion motor.	<ul style="list-style-type: none"> • Measure drain quantity from propulsion motor. • If drain quantity is larger than standard value, repair propulsion motor or replace it if necessary.
6. Propulsion Pump	Discharge flow rate is insufficient due to efficiency degradation of propulsion pump.	<ul style="list-style-type: none"> • Measure discharge flow rate of propulsion pump with flow meter. • If discharge flow rate is not within specified range, repair propulsion pump or replace it if necessary.
	Discharge flow rate is insufficient due to wear of propulsion pump drive shaft splines.	Replace propulsion pump.
	Propulsion circuit pressure is not held in propulsion pump case.	If pressure in propulsion pump case is not within allowable range, repair propulsion pump or replace it if necessary.

3-2-4. Machine does not stop completely with F-R lever in “N”

Check point	Cause	Check/Action
1. F-R lever Linkage	F-R lever linkage is faulty.	Check and adjust F-R lever linkage or replace it if necessary.
2. Servo Control Valve	Servo control valve neutral position adjustment failure.	Check and adjust servo control valve or replace it if necessary.
3. Propulsion Pump Servo Cylinder	Faulty propulsion pump servo cylinder or faulty pump swash plate setting.	Repair propulsion pump or replace it if necessary.

3-2-5. Driving not possible with differential locked (TW types)

Check point	Cause	Check/Action
1. Differential Lock Valve	Flow control valve is clogged or check valve is faulty.	Inspect flow control valve and check valve or replace it if necessary.

TROUBLESHOOTING

3-2-6. Propulsion system is overheating

Check point	Cause	Check/Action
1. Oil Level of Hydraulic Oil Tank	Oil level in hydraulic oil tank is low.	Fill tank until correct oil level is obtained.
2. Oil Cooler	Cooling efficiency is reduced due to clogged oil cooler fins.	Clean oil cooler fins.
3. Propulsion Circuit Pressure	If circuit pressure setting is excessively low, relief valve opens, causing temperature of hydraulic oil in circuit to rise.	<ul style="list-style-type: none"> • Measure propulsion circuit pressure. • If low, clean relief valve or replace it if necessary.
	If load is excessively heavy, relief valve opens, causing temperature of hydraulic oil in circuit to rise.	<ul style="list-style-type: none"> • Measure propulsion circuit pressure. • If high, decrease propulsion load.
4. Suction Filter for Charge Pump	Load of charge pump increases due to clogged filter, causing temperature of hydraulic oil in circuit to rise.	Clean suction filter or replace it if necessary.
5. Hydraulic Oil Filter	Charge circuit pressure increases due to clogged filter.	Clean hydraulic oil filter or replace it if necessary.

3-2-7. Abnormal noise from propulsion system

Check point	Cause	Check/Action
1. Axle Bearings	Axle bearings supporting front and rear drums are damaged.	Replace axle bearings.
2. Hydraulic Hose Clamp	Vibrator sound of hydraulic hose is generated because clamp securing hydraulic hose is loose.	Tighten bolts of loose hydraulic hose clamp to specified torque.
3. Suction Filter for Charge Pump	Cavitation is occurring in charge pump due to clogged filter.	Clean suction filter or replace it if necessary.
4. Charge Circuit Pressure	If charge pressure is low, brake cannot be released completely, which causes brake drag.	<ul style="list-style-type: none"> • Measure charge pressure. • If low, check and adjust charge relief valve or replace it if necessary.
5. Propulsion Motor	Internal bearing of propulsion motor is damaged.	Repair propulsion motor or replace it if necessary.

3-3. Vibrator System

If a problem occurs in the vibrator systems such as the vibrator pump, vibrator motor and vibrator solenoid valve, determine the cause and carry out action as required, according to the following general troubleshooting items.

(NOTICE)

- When checking whether or not the pressure is correct, refer to the pressure standard value for each hydraulic circuit.

3-3-1. No vibration

Check point	Cause	Check/Action
1. Oil Level of Hydraulic Oil Tank	Oil level in hydraulic oil tank is low.	Fill tank until correct oil level is obtained.
2. Suction Filter for Vibrator Pump	Vibrator pump flow is reduced due to clogged filler.	Clean suction filter or replace it if necessary.
3. Vibrator Solenoid Valve	Circuit does not obtain required pressure because vibrator solenoid does not shift.	Repair vibrator solenoid valve or replace it if necessary.
4. Vibrator Motor	Internal leakage of vibrator motor.	<ul style="list-style-type: none"> • Measure drain quantity from vibrator motor. • If drain quantity is larger than standard value, repair vibrator motor or replace it if necessary.
	Output torque is not transmitted due to worn spline of vibrator motor output shaft.	Replace vibrator motor.
5. Vibrator Pump	Insufficient discharge rate from vibrator pump due to reduced efficiency of vibrator pump.	<ul style="list-style-type: none"> • Measure discharge flow rate of vibrator pump with flow meter. • If discharge flow rate is not within specified range, repair vibrator pump or replace it if necessary.
	Insufficient pump discharge due to wear of vibrator pump drive shaft spline.	Replace vibrator pump.
	Vibrator circuit pressure is not held in vibrator pump case.	If pressure in vibrator pump case is not within allowable range, repair vibrator pump or replace it if necessary.

TROUBLESHOOTING

3-3-2. Vibrator frequency is too low

Check point	Cause	Check/Action
1. Oil Level of Hydraulic Oil Tank	Oil level in hydraulic oil tank is low.	Fill tank until correct oil level is obtained.
2. Vibrator Circuit Pressure	Circuit does not obtain required pressure because setting pressure of relief valve is low.	<ul style="list-style-type: none"> • Measure vibrator circuit pressure. • If low, check relief valve or replace it if necessary.
3. Suction Filter for Vibrator Pump	Flow rate of vibrator pump decreases as well as charge pressure decreases due to clogged filter.	Clean suction filter or replace it if necessary.
4. Vibrator Motor	Decrease in vibrator motor rpm due to internal leakage in vibrator motor.	<ul style="list-style-type: none"> • Measure drain quantity from vibrator motor. • If drain quantity is larger than standard value, repair vibrator motor or replace it if necessary.
5. Vibrator Pump	Insufficient discharge rate from vibrator pump due to reduced efficiency of vibrator pump.	<ul style="list-style-type: none"> • Measure discharge flow rate of vibrator pump with flow meter. • If discharge flow rate is not within specified range, repair vibrator pump or replace it if necessary.
	Insufficient pump discharge due to wear of vibrator pump drive shaft spline.	Replace vibrator pump.

3-3-3. Vibrator does not stop

Check point	Cause	Check/Action
1. Vibrator Solenoid Valve	Vibrator solenoid does not return to vibration mode select switch "O" (OFF) position.	Repair vibrator solenoid valve or replace it if necessary.

3-3-4. Vibrator system is overheating

Check point	Cause	Check/Action
1. Oil Level of Hydraulic Oil Tank	Oil level in hydraulic oil tank is low.	Fill tank until correct oil level is obtained.
2. Vibrator Circuit Pressure	If load is excessively heavy, relief valve opens, causing temperature of hydraulic oil in circuit to rise.	<ul style="list-style-type: none"> • Measure vibrator circuit pressure. • If high, decrease vibration load.
3. Suction Filter for Vibrator Pump	Load of vibrator pump increases due to clogged filter, causing temperature of hydraulic oil in circuit to rise.	Clean suction filter or replace it if necessary.

3-3-5. Abnormal noise from vibrator system

Check point	Cause	Check/Action
1. Vibrator Bearings	Vibrator bearings supporting eccentric shaft are damaged.	Replace vibrator bearings.
2. Hydraulic Hose Clamp	Vibrator sound of hydraulic hose is generated because clamp securing hydraulic hose is loose.	Tighten bolts of loose hydraulic hose clamp to specified torque.
3. Suction Filter for Vibrator Pump	Cavitation is occurring in vibrator pump due to clogged filter.	Clean suction filter or replace it if necessary.
4. Vibrator Motor	Internal bearing of vibrator motor is damaged.	Repair vibrator motor or replace it if necessary.

TROUBLESHOOTING

3-4. Steering System

If a problem occurs in the steering systems such as the steering pump and orbitrol, determine the cause and carry out action as required, according to the following general troubleshooting items.

(NOTICE)

- When checking whether or not the pressure is correct, refer to the pressure standard value for each hydraulic circuit.

3-4-1. Steering wheel is hard to turn

Check point	Cause	Check/Action
1. Oil Level of Hydraulic Oil Tank	Oil level in hydraulic oil tank is low.	Fill tank until correct oil level is obtained.
2. Orbitrol	Relief valve is open or setting pressure is low.	<ul style="list-style-type: none"> • Measure steering circuit pressure. • If low, check and clean relief valve or replace it if necessary.
	Flow to steering cylinder circuit is insufficient due to leakage from check valve.	Check and clean check valve or replace it if necessary.
	Spool and sleeve of orbitrol are contaminated or clearance is incorrect.	Check and clean orbitrol or replace it if necessary.
3. Steering Circuit Pressure	Pressure in return circuit from orbitrol increases due to clogged charging hydraulic filter.	Clean hydraulic filter or replace it if necessary.
4. Steering Cylinder	Cylinder thrust decreases due to internal leakage of steering cylinder.	Repair steering cylinder or replace it if necessary.
5. Suction Filter for Steering Pump	Steering pump discharge rate decreases due to clogged filter.	Clean suction filter or replace it if necessary.
6. Steering Pump	Discharging pressure is insufficient due to efficiency degradation of steering pump.	<ul style="list-style-type: none"> • Measure steering circuit pressure. • If low, replace steering pump.
7. Steering Column	Column shaft and orbitrol shaft center are misaligned.	Align column shaft with orbitrol shaft center or replace it if necessary.
	Column shaft bearing is worn or damaged.	Repair column shaft or replace it if necessary.

3-4-2. Steering response is slow

Check point	Cause	Check/Action
1. Oil Level of Hydraulic Oil Tank	Oil level in hydraulic oil tank is low.	Fill tank until correct oil level is obtained.
2. Orbitrol	Oil is bypassing because relief valve is open.	<ul style="list-style-type: none"> • Measure steering circuit pressure. • If low, inspect relief valve or replace it if necessary.
3. Steering Cylinder	Internal leakage of steering cylinder.	Repair steering cylinder or replace it if necessary.
4. Suction Filter for Steering Pump	Steering pump discharge rate decreases due to clogged filter.	Clean suction filter or replace it if necessary.
5. Steering Pump	Discharging pressure is insufficient due to efficiency degradation of steering pump.	<ul style="list-style-type: none"> • Measure steering circuit pressure. • If low, replace steering pump.

3-4-3. Steering wheel backlash or play is large

Check point	Cause	Check/Action
1. Steering Column	Spline of column shaft or orbitrol is worn.	Replace column shaft or orbitrol.
	Column shaft bearings are worn.	Replace column shaft bearings.
2. Steering Wheel	Serration (spline) of wheel or column shaft is worn.	Replace wheel or column shaft.

3-4-4. Steering system is overheating

Check point	Cause	Check/Action
1. Oil Level of Hydraulic Oil Tank	Oil level in hydraulic oil tank is low.	Fill tank until correct oil level is obtained.
2. Oil Cooler	Cooling efficiency is reduced due to clogged oil cooler fins.	Clean oil cooler fins.
3. Steering Circuit Pressure	If circuit pressure setting is excessively low, relief valve is open, causing temperature of hydraulic oil in circuit to rise.	<ul style="list-style-type: none"> • Measure steering circuit pressure. • If low, replace relief valve.
	If load is excessively heavy, relief valve is open, causing temperature of hydraulic oil in circuit to rise.	<ul style="list-style-type: none"> • Measure steering circuit pressure. • If high, decrease steering load.
4. Suction Filter for Steering Pump	Load of steering pump increases due to clogged filter, causing temperature of hydraulic oil in circuit to rise.	Clean suction filter or replace it if necessary.

3-4-5. Abnormal noise from steering system

Check point	Cause	Check/Action
1. Oil Level of Hydraulic Oil Tank	Pump suction pressure is high because oil level of hydraulic oil tank is low, causing cavitation in steering circuit system.	Fill tank until correct oil level is obtained.
2. Steering Circuit	Cavitation is caused by air in circuit.	Bleed circuit.
3. Hydraulic Hose Clamp	Vibrator sound of hydraulic hose is generated because clamp securing hydraulic hose is loose.	Tighten bolts of loose hydraulic hose clamp to specified torque.
4. Suction Filter for Steering Pump	Cavitation is occurring in steering pump due to clogged filter.	Clean suction filter or replace it if necessary.

SAKAI HEAVY INDUSTRIES, LTD.

Head office: Seiwa Bldg., 4-8, Shibadaimon 1-chome,
Minato-ku, Tokyo, Japan

Telephone: +81-3-3434-3401

Global Service Division: 2500 Takayanagi, Kuki-shi, Saitama, Japan

Telephone: +81-480-52-1111

Copyright © 2012 SAKAI HEAVY INDUSTRIES, LTD. All Rights Reserved.

Printed in Japan 2012.11.50 © M.B

0445-99015-0-30697-C

0425-99006-0-30073-C