

GW754

SHOP MANUAL

SAKAI®

3498-6539B-0

Introduction

This manual provides important information to familiarize you with safe operating and maintenance procedures for your SAKAI roller. Even though you may be familiar with similar equipment you must read and understand this manual before operating or servicing this unit.

Safety is everyone's business and it is one of your primary concerns. Knowing the guidelines presented in this manual will help provide for your safety, for the safety of those around you and for the proper operation and maintenance of the machine. Improper operation is dangerous and can result in injury or death.

Sakai Heavy Industries cannot foresee all possible circumstances or varying conditions to which the operator, serviceman or machine may be exposed to that might lead to a potential hazard. Therefore, the warnings and cautions listed in this manual and those placed on the machine are not intended to be all inclusive and liability for personal injury or damage to equipment or property cannot be assumed.

All information, specifications and illustrations in this publication are based on the product information available at the time that the publication was written. The contents may change without prior notice due to modifications of the model.

CONTENTS

1. SAFETY

1. GENERAL SAFETY

1-1. Understanding the Safety Symbols and Words	1-001
1-2. General	1-001
1-3. Qualifications of Operators and Maintenance Personnel	1-002
1-4. Safety Practices and Policies	1-002
1-5. Pre Start Inspection	1-003
1-6. Safety Instructions	1-003
1-7. Starting	1-004
1-8. Operating	1-004
1-9. Stopping	1-004
1-10. Maintenance	1-005
1-11. Transporting the Machine	1-007

2. SPECIFICATIONS

1. SPECIFICATION DATA

1-1. GW754	2-001
------------------	-------

2. TABLE OF STANDARD VALUES

2-1. Engine	2-004
2-2. Propulsion	2-004
2-3. Hydraulic System	2-004
2-4. Steering	2-005
2-5. Brakes	2-005
2-6. Capacities	2-005

3. FUEL AND LUBRICANTS SPECIFICATION

3-1. Rating	2-006
3-2. Recommended Lubricants	2-006

4. TIGHTENING TORQUE CHART	2-007
----------------------------------	-------

3. ENGINE AND CONTROLS

1. ENGINE

1-1. Engine Mount	3-001
1-2. Engine Exterior	3-002

2. FUEL SYSTEM	3-003
----------------------	-------

3. EXHAUST SYSTEM	
3-1. Exhaust System	3-005
3-1-1. DPF ASSY	3-006
3-1-2. SCR ASSY	3-007
3-2. Urea Piping	3-008
3-2-1. DEF pump	3-009
3-2-2. DEF tank	3-010
4. CONTROL SYSTEM	
4-1. Forward-reverse Control	3-011
4-1-1. Shift lever SUBASSY	3-012
5. PUMP MOUNT	
5-1. Pump Mount	3-013
5-1-1. Installation of pump	3-014

4. HYDRAULIC SYSTEMS

1. SYSTEM CIRCUIT DIAGRAM	
1-1. Graphic Symbols for Hydraulic Circuits	4-001
1-2. Hydraulic Circuit Diagram	4-003
2. PROPULSION HYDRAULIC SYSTEM	
2-1. Propulsion Hydraulic Piping	4-004
2-1-1. Propulsion hydraulic piping (pump)	4-004
2-1-2. Propulsion hydraulic piping (motor) (1)	4-005
2-1-3. Propulsion hydraulic piping (motor) (2)	4-006
2-2. Hydraulic Component Specifications	4-007
2-2-1. Propulsion hydraulic pump	4-007
2-2-2. Propulsion hydraulic motor	4-008
2-2-3. Block ASSY (propulsion)	4-009
2-2-4. Block ASSY (front)	4-011
2-2-5. Servo bypass solenoid valve	4-012
2-2-6. Parking brake solenoid valve	4-013
2-2-7. Brake valve	4-014
2-3. Description and Operation of Propulsion System	4-016
3. VIBRATOR HYDRAULIC SYSTEM	
3-1. Vibrator Hydraulic Piping	4-019
3-1-1. Vibrator hydraulic piping (pump)	4-019
3-1-2. Vibrator hydraulic piping (motor) (1)	4-020
3-1-3. Vibrator hydraulic piping (motor) (2)	4-021
3-1-4. Amplitude cylinder piping (1)	4-022
3-1-5. Amplitude cylinder piping (2)	4-023

3-2. Hydraulic Component Specifications	4-024
3-2-1. Vibrator hydraulic pump	4-024
3-2-2. Vibrator hydraulic motor (F)	4-025
3-2-3. Vibrator hydraulic motor (R,L), (R,R)	4-026
3-2-4. Valve block ASSY (amplitude)	4-027
3-2-5. Amplitude cylinder (F)	4-029
3-2-6. Amplitude cylinder (R,L), (R,R)	4-030
3-2-7. Vibrator solenoid valve (F), (R)	4-031
3-2-8. Flow divider	4-032
3-3. Description and Operation of Vibrator System	4-034
4. STEERING SYSTEM	
4-1. Steering Hydraulic Piping	4-035
4-2. Steering Wheel	4-036
4-3. Hydraulic Component Specifications	4-037
4-3-1. Steering • charge pump	4-037
4-3-2. Orbitrol	4-038
4-4. Description and Operation of Steering System	4-040
4-4-1. Description and operation of steering system	4-040
4-4-2. Structure and operation of Orbitrol	4-041
5. ELECTRICAL SYSTEM	
1. PRECAUTIONS FOR WORK	
1-1. Wire Numbers, Wire Sizes, Wire Colors and Connectors Shown in Electrical Circuit Diagram, Wiring Harness Layout and Wiring Harnesses	5-001
2. SYSTEM CIRCUIT DIAGRAM	
2-1. Electrical Circuit Diagram	5-003
3. ELECTRICAL COMPONENTS	
3-1. Wiring Harness Layout (1)	5-004
3-2. Wiring Harness Layout (2)	5-005
3-3. Wiring Harness Layout (3)	5-006
4. WIRING HARNESES	
4-1. Fuse • Relay Harness	5-007
4-2. Amplitude Cylinder Solenoid Harness	5-009
4-3. ECU Harness	5-011
4-4. ACU Harness	5-013
4-5. Dashboard Harness	5-015
4-6. Air Flow Sensor Harness	5-017
4-7. Battery Relay Harness	5-019
4-8. Member (F) Harness	5-020

4-9. Member (R) Harness	5-021
4-10. Battery Box Connect Harness	5-022
4-11. Engine Harness	5-023
4-12. Starter Switch Harness	5-024
4-13. Head Lamp Harness	5-025
4-14. F-R Lever Harness	5-026
4-15. F-R Lever Vibration Switch Harness	5-027
4-16. Amplitude Cylinder Switch Harness (F)	5-028
4-17. Amplitude Cylinder Switch Harness (R,L)	5-029
4-18. Amplitude Cylinder Switch Harness (R,R)	5-030
4-19. Water Spray Pump Harness	5-031
4-20. Cord	5-032
4-21. Ground Cord 1	5-033
4-22. Ground Cord 2	5-034
4-23. Ground Cord 3	5-035
5. ELECTRICAL COMPONENT SPECIFICATIONS	
5-1. Fuse Box 1	5-036
5-2. Fuse Box 2	5-037
5-3. Combination Meter	5-038

6. WHEEL AND VIBRATOR SYSTEM

1. PRECAUTIONS FOR DISASSEMBLY AND REASSEMBLY	6-001
2. FRONT WHEEL	
2-1. Removal and Installation of Front Wheel ASSY	6-003
2-1-1. Removal of front wheel ASSY	6-003
2-1-2. Installation of front wheel ASSY	6-006
2-2. Front Wheel ASSY	6-007
2-3. Disassembly and Reassembly of Front Wheel	6-008
2-3-1. Disassembly of front wheel	6-008
2-3-2. Reassembly of front wheel	6-017
3. REAR WHEEL	
3-1. Removal and Installation of Rear Wheel ASSY	6-037
3-1-1. Removal of rear wheel ASSY	6-037
3-1-2. Installation of rear wheel ASSY	6-042
3-2. Rear Wheel ASSY	6-043
3-3. Disassembly and Reassembly of Rear Wheel	6-044
3-3-1. Disassembly of rear wheel	6-044
3-3-2. Reassembly of rear wheel	6-055

7. BRAKE

- 1. BRAKE PEDAL 7-001
- 2. BRAKE SYSTEM
 - 2-1. Description and Operation of Brake Circuit 7-003

8. OPERATOR STATION

- 1. FLOORBOARD
 - 1-1. Structure of Operator Station 8-001
 - 1-2. Adjustment of Swivel Lock Release Pedal 8-002

9. WATER SPRAY SYSTEM

- 1. WATER SPRAY PIPING
 - 1-1. Water Spray Piping (1) 9-001
 - 1-2. Water Spray Piping (2) 9-002
- 2. LIQUID SPRAY SYSTEM
 - 2-1. Liquid Spray Piping (1) 9-003
 - 2-2. Liquid Spray Piping (2) 9-004
- 3. WATER SPRAY COMPONENT SPECIFICATIONS
 - 3-1. Change Over Solenoid Valve 9-005
 - 3-2. Liquid Spray Solenoid Valve (F), (R) 9-006

10. INSPECTION AND ADJUSTMENT

- 1. INSPECTION AND ADJUSTMENT
 - 1-1. Safety Precautions for Inspection and Adjustment 10-001
 - 1-2. Preparation for Inspection and Adjustment 10-001
 - 1-3. Precautions for Inspection and Adjustment 10-001
 - 1-4. Warm-up 10-001
 - 1-5. Inspection and Adjustment of Engine Related Items 10-001
- 2. MEASUREMENT AND INSPECTION OF PROPULSION CIRCUIT PRESSURE
 - 2-1. Measurement 10-002
 - 2-2. Inspection 10-003
- 3. MEASUREMENT AND ADJUSTMENT OF PROPULSION CHARGE CIRCUIT PRESSURE
 - 3-1. Measurement 10-004
 - 3-2. Adjustment 10-005
- 4. MEASUREMENT AND ADJUSTMENT OF PROPULSION SERVO CIRCUIT PRESSURE
 - 4-1. Measurement 10-006
 - 4-2. Adjustment 10-007

5. MEASUREMENT OF PARKING BRAKE RELEASE PRESSURE	
5-1. Measurement	10-008
6. MEASUREMENT AND ADJUSTMENT OF VIBRATOR CIRCUIT PRESSURE	
6-1. Measurement	10-009
6-2. Adjustment	10-010
7. MEASUREMENT AND INSPECTION OF STEERING CIRCUIT PRESSURE	
7-1. Measurement	10-011
7-2. Inspection	10-012
8. ADJUSTMENT OF F-R LEVER AND SHIFT LEVER	
8-1. Adjustment of Linkage	10-013
8-2. Adjustment of Operating Force	10-015
8-2-1. Adjustment of F-R lever	10-015
8-2-2. Adjustment of shift lever	10-016

11. TROUBLESHOOTING

1. TROUBLESHOOTING	
1-1. Safety Precautions for Troubleshooting	11-001
1-2. Important Information for Troubleshooting	11-001
1-3. Before Starting	11-002
2. ELECTRICAL SYSTEM TROUBLESHOOTING	
2-1. When Performing Electrical System Fault Diagnosis	11-003
2-1-1. Precautions to take during electrical circuit fault diagnosis	11-003
2-1-2. Inspection procedures using a tester	11-004
2-1-3. Inspection of electrical system	11-009
2-2. Engine Diagnosis Trouble Code	11-011
2-2-1. Description of fault code (SPN, FMI)	11-011
2-2-2. Fault code list (SPN, FMI)	11-012
2-3. Engine	11-021
2-3-1. Engine will not start (Starter motor does not run) 1/3	11-021
2-3-1. Engine will not start (Starter motor does not run) 2/3	11-023
2-3-1. Engine will not start (Starter motor does not run) 3/3	11-025
2-3-2. Engine will not start (But starter motor runs)	11-027
2-3-3. No charging	11-027
2-3-4. Intake heater is not heated (Engine starting performance is bad in cold weather)	11-029
2-3-5. Starter motor runs even when F-R lever is not at "N"	11-029
2-3-6. Engine speed cannot be switched	11-029

2-4. Propulsion System	11-031
2-4-1. Machine moves neither forward nor backward	11-031
2-4-2. Brake cannot be released	11-033
2-4-3. Brake does not work	11-035
2-5. Vibration	11-037
2-5-1. No vibration occurs 1/2	11-037
2-5-1. No vibration occurs 2/2	11-039
2-5-2. Vibration amplitude does not change (It vibrates at Amplitude 1, but vibration amplitude does not switch over at Amplitude 2 to 4 positions) 1/2	11-041
2-5-2. Vibration amplitude does not change (It vibrates at Amplitude 1, but vibration amplitude does not switch over at Amplitude 2 to 4 positions) 2/2	11-043
2-5-3. Vibration amplitude does not change (The vibration amplitude switches only between the minimum (Amplitude 1) and the maximum (Amplitude 4)) 1/2	11-045
2-5-3. Vibration amplitude does not change (The vibration amplitude switches only between the minimum (Amplitude 1) and the maximum (Amplitude 4)) 2/2	11-047
2-5-4. Vibration mode cannot be switched (F-R lever vibration switch does not work)	11-049
2-6. Water Spray	11-051
2-6-1. Continuous water spray does not operate 1/3	11-051
2-6-1. Continuous water spray does not operate 2/3	11-053
2-6-1. Continuous water spray does not operate 3/3	11-055
2-6-2. Continuous water spray works, but auto water spray does not operate	11-057
2-6-3. Continuous water spray works, but intermittent water spray does not operate	11-059
2-6-4. Water is not supplied from water spray tank (R)	11-061
2-6-5. Liquid cannot be sprayed	11-063
2-7. Lighting	11-065
2-7-1. Head lamp does not light	11-065
2-7-2. Flood lamp does not light	11-067
2-7-3. High-beam of head lamp does not light	11-067
2-7-4. Illumination of combination meter does not light	11-069
2-7-5. Combination meter warning lamp or indicator lamp is abnormal	11-069
2-7-6. Tachometer reading is abnormal	11-071
2-7-7. Hour meter is abnormal	11-071
2-7-8. Temperature meter is abnormal	11-073

2-7-9. Fuel meter is abnormal	11-073
2-7-10. Hydraulic oil filter warning lamp remains ON	11-075
2-7-11. Charge warning lamp remains ON	11-075
2-7-12. Water spray indicator lamp does not light	11-077
2-7-13. Liquid spray indicator lamp does not light	11-079
2-7-14. Flood lamp indicator lamp does not light	11-081
2-7-15. Parking brake indicator lamp does not light	11-081
2-7-16. Amplitude lamp (A) does not light	11-083
2-7-17. Amplitude lamp (B) does not light	11-085
2-7-18. Horn does not sound	11-087
2-7-19. Backup buzzer does not sound	11-087

3. HYDRAULIC SYSTEM TROUBLESHOOTING

3-1. When Performing Hydraulic System Troubleshooting	11-088
3-2. Propulsion System	11-089
3-2-1. Machine moves neither forward nor backward 1/2	11-089
3-2-1. Machine moves neither forward nor backward 2/2	11-090
3-2-2. Machine moves in one direction only (forward or backward)	11-090
3-2-3. Slow machine speed or small drive force	11-091
3-2-4. Machine does not stop completely with F-R lever in "N"	11-092
3-2-5. Propulsion system is overheating	11-092
3-2-6. Abnormal noise from propulsion system	11-092
3-3. Vibrator System	11-093
3-3-1. No vibration	11-093
3-3-2. Vibrator frequency is too low	11-094
3-3-3. Amplitude cannot be switched between high and low	11-094
3-3-4. Vibrator does not stop	11-095
3-3-5. Vibrator system is overheating	11-095
3-3-6. Abnormal noise from vibrator system	11-095
3-4. Steering System	11-096
3-4-1. Steering wheel is hard to turn	11-096
3-4-2. Steering response is slow	11-096
3-4-3. Steering wheel backlash or play is large	11-097
3-4-4. Steering system is overheating	11-097
3-4-5. Abnormal noise from steering system	11-097
3-5. Brake System	11-098
3-5-1. Parking brake does not operate	11-098
3-5-2. Brake cannot be released	11-098

SAFETY

1. GENERAL SAFETY

1-1. Understanding the Safety Symbols and Words

The words DANGER, WARNING, and CAUTION are used with the safety-alert symbol. DANGER identifies the most serious hazard. When the symbols DANGER, WARNING and CAUTION are displayed, become alert. Your safety or those around you may be involved. NOTICE is used to provide important information that is not hazard related.

 **DANGER:** Indicates an imminently hazardous situation or condition which if not avoided can result in serious personal injury or death.

 **WARNING:** Indicates a potentially hazardous situation or condition which if not avoided can result in serious personal injury or death.

 **CAUTION:** Indicates a potentially hazardous situation or condition which if not avoided may result in moderate personal injury or damage to the machine or personal property.

(NOTICE): Indicates important information about operation or maintenance of the machine that may cause damage, breakdown, or shortened service life of the machine if you fail to observe or important point to maintain of quality in maintenance works.

★: Indicates standard value to judge whether measured value is good or not.



Items that indicate the weight of a part or equipment and require attention in wire selection and operating posture for slinging operation.



In the assembly operation, tightening torque in locations that require particular attention.

1-2. General

- Operators and maintenance personnel must be alert to recognize and avoid potential hazards. They should also have comprehensive training, the required skills and necessary tools to perform the job safely.
- The machine was built in accordance to the latest safety standards and recognized safety rules. Nevertheless, misuse of the machine may result in risk to life and limb of the user or nearby personnel and may cause damage to the machine or other property.
- The machine must only be used for its intended purpose as described in the Operator's Manual. It must be operated by safety-conscious persons who are fully aware of the risks involved when operating the machine. Any malfunctions especially those affecting the safety of the machine must be corrected immediately.

- The machine is designed specifically for the compaction of asphalt or soil road construction materials. Use of the machine for other purposes such as towing other equipment is considered contrary to the designated use. The manufacturer cannot be responsible or held liable for any damage resulting from such use. The risk for such use lies entirely with the user.
- Operating the machine within the limits of its designated use also involves compliance with the inspection and maintenance requirements contained in the Operation and Maintenance Manual.

1-3. Qualifications of Operators and Maintenance Personnel

- Work on the machine must be performed by qualified personnel only. Individual responsibilities of personnel regarding operation, maintenance, repair of the machine must be clearly stated.
- Define the operator's responsibilities; the operator should have authority to refuse instructions that are contrary to safety.
- Do not allow persons being trained to operate or perform maintenance on the machine without constant supervision by an experienced person.
- Work on the electrical system of the machine must be done only by an experienced person or under the guidance of a skilled electrician and according to electrical engineering rules and regulations.
- Work on the frame, brakes, hydraulic and steering systems must be performed by skilled personnel with special knowledge and training for such work.

1-4. Safety Practices and Policies

- Keep the manuals in the container provided on the machine. Manuals must always be available at the site where the machine is being used.
- The operator or user of the machine must be aware of all applicable or legal and mandatory regulations relevant to accident prevention and environmental protection. These regulations may also deal with handling of hazardous substances, the required proper personal safety and protective equipment and traffic or jobsite regulations.
- Machine operating instructions should also be supplemented with detailed instructions pertaining to the specific jobsite or work location.
- Always be sure the persons working on the machine have read the operating instructions and all safety precautions before beginning work. Reading safety instructions after work has already begun is too late.
- Wear close fitting garments and always tie back and secure long hair, also avoid wearing jewelry such as rings. Injury can result from loose clothing, hair or jewelry being caught up in the machinery or rotating parts.
- Use protective equipment as required by the circumstances or by law.

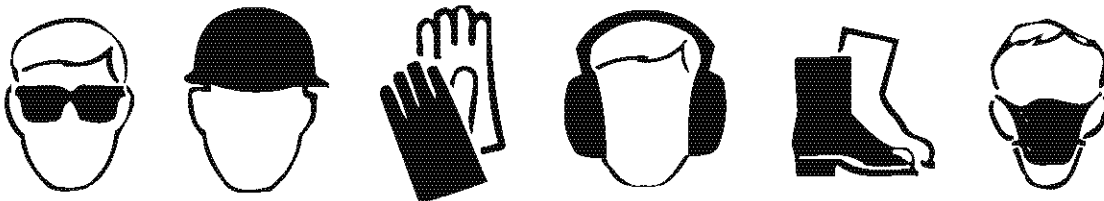

- Observe all safety instructions and warnings attached to the machine.
- Make sure all safety instructions and warnings on the machine are complete and perfectly legible.
- Stop the machine immediately in the event of any malfunction. Report any malfunction immediately to the supervisor or other person of authority.
- Never perform service or maintenance on the machine unless the drums or tires are adequately blocked, articulation lock bar and pin is in the locked position and the parking brake is applied.
- Never make any modifications to the machine which might affect safety without the manufacturer's approval.
- Always perform the recommended routine inspections and adjustments according to the prescribed intervals.

1-5. Pre Start Inspection

- Inspect your machine daily. Ensure that the routine maintenance and lubrication are properly performed. Repair or replace any malfunctioning, broken or missing parts before using the machine. Refer to the maintenance schedule in the Operator's Manual.
- Check that all instructions and safety stickers are in place and readable.
- Never fill the fuel tank with the engine running or while near an open flame or while smoking.
- Always clean up any spilled fuel.
- Check for any warning tags placed on the machine, do not operate the machine until all repairs have been made and warning tags have been removed by authorized personnel.
- Check the seat belt for wear or damage; inspect the belt hardware and fabric. Replace if hardware is damaged or the belt is frayed or nicked or stitching is loose. Check that mounting hardware is tight.
- Clean the steps and operating platform of dirt and foreign matter to reduce danger of slipping.
- Know how to shut-down or stop the machine immediately in case of emergency.
- Know the capabilities and limitations of the machine such as speed, gradeability, steering and braking.
- Be aware of the dimensions of the machine such as height, weight especially for transporting.

1-6. Safety Instructions

- Take all necessary precautions to ensure that the machine is used only when in a safe and reliable condition.
- Avoid any operational mode that might compromise safety.
- Operate the machine only if all protective and safety devices are in place and fully functional.
- Always use the hand rails and steps to get on and off your machine maintaining 3-point contact (using both hands).

1-7. Starting

- Start the machine only from the driver's seat and always wear the seat belt.
- Watch that the warning lights and indicators during start-up and shutdown are working in accordance with operating instructions.
- Watch that no one is in danger before starting and when moving the machine.
- Check that braking, steering, signals and lights are fully functional before starting work or traveling with the machine.

1-8. Operating

- Always make sure that there are no obstructions or persons in your line of travel before starting the compactor in motion.
- Never climb on and off the machine while it is in motion.
- Always remain seated with the seat belt fastened when traveling, compacting or loading or unloading the machine.
- Use caution and be very observant when operating in close quarters and congested areas.
- Obey all traffic regulations when working on public roads and make sure machine is compatible with these regulations.
- Never carry passengers.
- Know and use the hand signals for particular jobs and who has the responsibility for signaling.
- Do not work close to edges or in the vicinity of overhanging banks or on grades that could cause the compactor to slide or roll over. Avoid any areas that may be a risk to machine stability.
- Avoid side hill travel. Always operate up and down the slope. Always keep the propulsion (travel control) lever in low speed range when climbing or descending hills or steep grades.
- Make sure there is sufficient clearance when crossing underpasses, bridges and tunnels or when passing under overhead power lines.
- Never allow anyone to stand in the articulation area of the machine when the engine is running.
- Always look in all directions before reversing the direction of travel.
- Always switch on the lighting system (if equipped) during poor visibility conditions and after dark.
- Do not attempt to control the compactor travel speed with the throttle control. Maintain engine speed at the full operating RPM.
- Do not run the engine in a closed building for an extended period of time. Exhaust fumes can kill.

1-9. Stopping

- Always park the machine in a safe area on solid and level ground. If this is not possible, always park at a right angle to the slope and block the drums or tires.
- Do not leave the operator's platform with the engine running. Always move the travel lever to neutral position and apply the parking brake then turn the starter switch to OFF.
- Lock all lockable compartments.
- Park behind a safe barrier, use proper flags, and warning devices, especially when parking in areas of heavy traffic.

1-10. Maintenance

- In any performing any work concerning the operation, adjustment or modification of the machine or it's safety devices or any work related to maintenance, inspection or repair, always follow the start-up and shut-down procedures in the Operator's Manual and the Maintenance Manual.
- Ensure that the maintenance area is safe and secure.
- If the machine is shut down for maintenance or repair work it must be secured against inadvertent starting by removing the starter key and attaching a warning sign to the starter switch.
- The machine must be parked on stable and level ground with the drums or tires blocked to prevent inadvertent movement.
- Immediately after the engine has stopped, the exhaust system, engine, radiator coolant, engine oil, hydraulic fluid and other lubricants and components will be very hot. Fluids can be under pressure, removing the radiator cap or draining oil or changing filters can cause serious burns. Wait until the machine has cooled down.
- Use care when attaching and securing lifting tackle to individual parts and large assemblies being removed or repositioned for repair purposes to avoid the risk of accident. Use lifting devices that are in perfect condition and of sufficient lifting capacity. Never stand under suspended loads.
- Always use the proper tools and workshop equipment in good condition when performing maintenance or repairs on the machine.
- Always use specially designed safety ladders and working platforms when working above floor level. Never use machine parts as a climbing aid.
- Keep all steps, handles, handrails, platforms and ladders free from mud, dirt, grease, ice or snow.
- Clean the machine, especially threaded connections of any traces of oil or fuel before carrying out any maintenance or repairs. Never use aggressive detergents. Use lint free cleaning rags.
- Examine all fuel, lubricant and hydraulic fluid lines and connectors for leaks, loose connections chafe marks or damage after cleaning.
- Repair or replace defective parts immediately.
- Whenever possible, avoid servicing or maintenance when the engine is running unless the drums or tires are adequately blocked, the articulation lock bar is in the locked position and the parking brake is applied.
- Never fill the fuel tank with the engine running, while near an open flame or while smoking. Always clean up any spilled fuel.
- Ensure safe operation, optimum performance of the machine and its warranty by using only genuine SAKAI replacement parts.

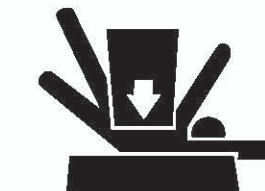
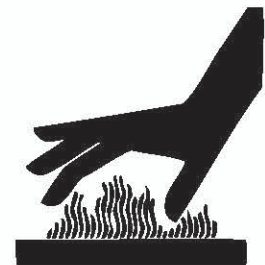

- Use only the specified fluids and lubricants. Substitute only products known to be equivalent from reputable manufacturers.
- Disconnect the battery cables when working on the electrical system or when welding on the compactor.
- Be sure the battery area is well ventilated (clear of fumes) should it be necessary to connect a jumper cable or battery charger. Fumes can ignite from a spark and may explode.
- Be sure battery charger is OFF when making connections if charging is required.
- Use only original fuses with the specified rating. Switch off the machine immediately if trouble occurs in the electrical system.
- Work on the electrical system may only be carried out by a qualified electrician or by a specially trained person according to electrical engineering principles.
- Inspect the electrical equipment of the machine at regular intervals. Defects such as loose connections or burnt or scorched wires must be repaired or replaced immediately.
- Do not weld, flame cut or perform grinding on the machine unless expressly authorized, as there may be a risk of fire or explosion. Disconnect the battery when welding on the machine.
- Clean the machine and its surrounding from dust or other flammable substances and make sure the area is adequately ventilated before beginning welding, flame cutting or grinding operations.
- Inspect hydraulic hoses at regular intervals and immediately replace if they show signs of chafing, cracking, brittleness, deformation, blistering, fitting separation, leakage, corrosion or other damage which may affect their function or strength.
- Do not work on hydraulic system while the engine is running and the system is under pressure. The hydraulic system remains pressurized even after the engine has stopped.
- Do not disconnect hydraulic hoses or fittings until the pressure has been properly relieved.
- Wait until the systems and fluid have cooled down before disconnecting.
- Never use your hands to check for leaks when inspecting a hydraulic system. Use a piece of cardboard and always wear gloves and safety glasses.

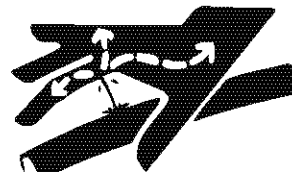
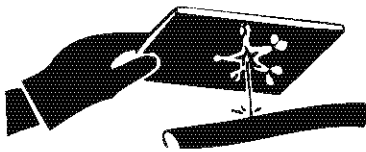
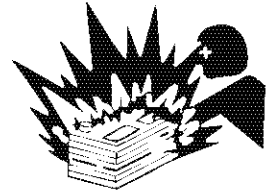

- Get immediate medical attention if fluid has been injected under your skin. Fluid penetration from a pin hole leak can cause severe injury or death.
- Ensure that hydraulic lines and hoses are routed and fitted properly. Ensure that no connections are interchanged. All fittings, lengths and specifications of hoses must comply with the technical requirements.
- Observe all product safety regulations when handling fuel, oils, grease, engine coolant and other chemical substances. Be careful especially when these items are hot as there is a risk of burning or scalding.
- Operate internal combustion engines and fuel operated heating systems only in adequately ventilated premises. Before starting the engine in an enclosed area, make sure there is sufficient ventilation.

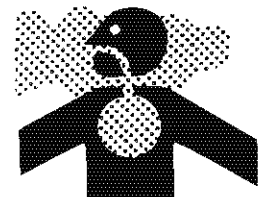

1-11. Transporting the Machine

- Use only suitable and approved trailers and haul vehicles and lifting equipment of sufficient capacity.
- Entrust to experienced personnel the fastening and lifting of loads and instructing of crane operators.
- Only experienced persons familiar with the operation of the machine may load and unload the machine.
- Use ramps or a loading dock when loading or unloading the machine. Ramps must be the proper strength, low angle and the proper height and width.
- Block the drums or tires (front and rear) of the hauling vehicle when loading and unloading the compactor. Ensure that the haul vehicle is on level ground and approach the loading ramps squarely to make sure that the compactor does not slide off the edge of the ramp.
- Keep the deck clear of mud, oil, ice or snow or other materials that can make the deck slippery.
- Position the compactor on the trailer or transport vehicle centered from side to side, and apply the brake. Shut off the engine and lock all lockable compartments.
- Block the drums or tires and lock the articulation lock bar. Chain the machine down properly using the appropriate tackle.
- Know the overall height of the compactor and hauling vehicle. Observe height and weight regulations and be sure you can pass safely at overhead obstructions.
- Obey all traffic regulations and be sure that the proper clearance flags, lights and warning signs including "Slow Moving Vehicle" emblem are displayed when traveling on public roads.
- Know the approximate stopping distance at any given speed.
- Drive Safely. Never turn corners at excessive speeds.

SPECIFICATIONS

1. SPECIFICATION DATA

1-1. GW754

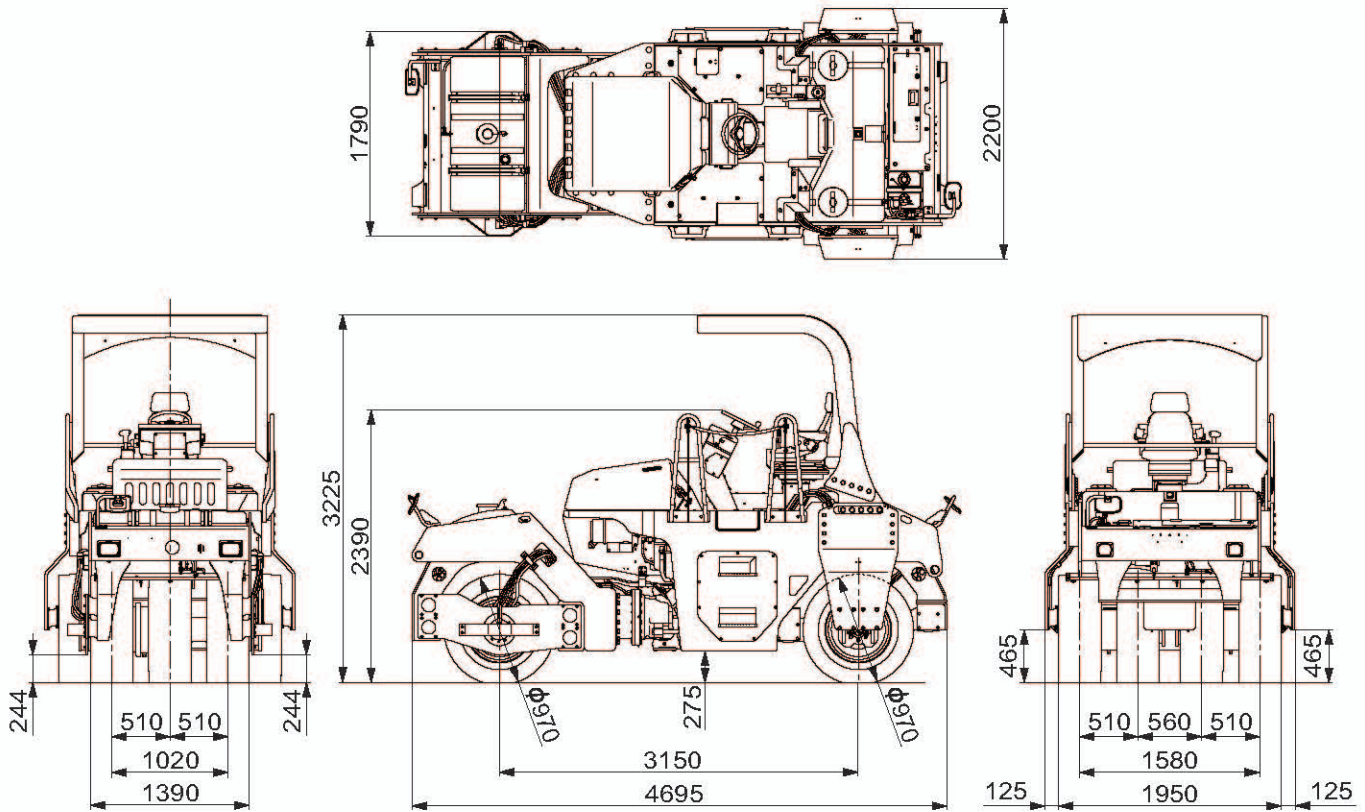

0539-99015-0-11258-0

Model & Type		SAKAI GW754 with ROPS		
Model		Type		
		VIBRATORY PNEUMATIC-TYRE ROLLER		
Weight	Operating weight	without ballast	8,850 kg (19,510 lbs.)	
		with ballast	N/A kg (N/A lbs.)	
	Maximum weight		9,270 kg (20,435 lbs.)	
	Shipping weight	with ROPS	8,360 kg (18,430 lbs.)	
		without ROPS	7,990 kg (17,615 lbs.)	
	Load on front axle	3,680 kg (8,115 lbs.)		
Load on rear axle	5,170 kg (11,395 lbs.)			
Dimensions	Overall length		4,695 mm (185 in.)	
	Overall width		2,200 mm (87 in.)	
	Overall height	with ROPS	3,225 mm (127 in.)	
		without ROPS	2,390 mm (94 in.)	
	Wheelbase		3,150 mm (124 in.)	
	Compaction width		1,950 mm (77 in.)	
	Front tyres	width × dia.	1,390 mm × 970 mm (55 in. × 38 in.)	
		Size	14/70-20-12PR	
		Inflation pressure	441 kPa (63.9 psi)	
	Rear tyres	width × dia.	1,950 mm × 970 mm (77 in. × 38 in.)	
		Size	14/70-20-12PR	
		Inflation pressure	441 kPa (63.9 psi)	
	Ground clearance		275 mm (10.8 in.)	
	Kerb clearance	Left	244 mm (9.7 in.)	
		Right	244 mm (9.7 in.)	
Side clearance	Left	125 mm (5.0 in.)		
	Right	125 mm (5.0 in.)		
Leveling blade width		N/A mm (N/A in.)		

Performance	Vibrator system	Front	Centrifugal force	1st	6 kN (1,350 lbf.)	
				2nd	19 kN (4,270 lbf.)	
				3rd	32 kN (7,195 lbf.)	
				4th	45 kN (10,115 lbf.)	
			Frequency	1st	40 Hz (2,400 vpm)	
				2nd	40 Hz (2,400 vpm)	
				3rd	40 Hz (2,400 vpm)	
				4th	40 Hz (2,400 vpm)	
		Amplitude	1st	0.10 mm (0.004 in.)		
			2nd	0.31 mm (0.012 in.)		
			3rd	0.53 mm (0.021 in.)		
			4th	0.74 mm (0.029 in.)		
		Rear	Centrifugal force	1st	8 kN (1,800 lbf.)	
				2nd	25 kN (5,620 lbf.)	
				3rd	42 kN (9,440 lbf.)	
				4th	58 kN (13,040 lbf.)	
	Frequency		1st	40 Hz (2,400 vpm)		
			2nd	40 Hz (2,400 vpm)		
			3rd	40 Hz (2,400 vpm)		
			4th	40 Hz (2,400 vpm)		
	Amplitude	1st	0.10 mm (0.004 in.)			
		2nd	0.31 mm (0.012 in.)			
		3rd	0.53 mm (0.021 in.)			
		4th	0.74 mm (0.029 in.)			
	Speed	Number of speed shift		2 speed		
		Speed range	1st	0 to 6 km/h (0 to 3.7 mph)		
			2nd	0 to 12 km/h (0 to 7.5 mph)		
	Gradeability		without vibration	37 % (20 °)		
Turning radius	Machine clearance radius inside		3.7 m (146 in.)			
	Machine clearance radius outside		5.9 m (233 in.)			
	Turning radius inside compacted surface		3.8 m (150 in.)			
	Turning radius outside compacted surface		5.7 m (225 in.)			
Steering / Oscillating angle		± 36.7 ° / ± 6.5 °				

Engine	Name		KUBOTA V3800-CR-TI-EV03 (Diesel, EPA-Tier 4)	
	Model		4-cycle, Water-cooled, 4-cylinder in-line, overhead valve, common rail type, with intercooler turbo	
	Bore × Stroke		100 mm × 120 mm (3.937 in. × 4.724 in.)	
	Displacement		3.769 L (230.0 cu.in)	
	Performance	Rated speed		2,400 min ⁻¹
		Rated output		81.8 kW (110 HP)
		Max. torque		379.3 N·m (280 lbf·ft) ----- at 1,500 min ⁻¹
		Fuel consumption rate		223 g/kW·h (0.367 lb/HP·h) ----- at 2,400 min ⁻¹
		Fuel consumption		21 L/h with full load (5.7 gal with full load)
	Fuel system	Fuel		Diesel (ASTM D975-2D)
		Fuel injection pump		High pressure common rail
		Fuel injection time regulator		Electric speed control
	Lubrication system	Lubrication type		Full forced pressure feed
		Oil filter type		Full flow plastic fiber element
		Oil cooler type		Integrated water cooled
	Air intake system	Air cleaner type		Dry
	Cooling system	Cooling type		Pressurized water forced circulation
		Cooling fan type		exhale
Electrical system	Alternator		12 V 80 A	
	Starter		12 V 3.0 kW	
	Battery		12 V (72Ah, CCA750A) × 2 pcs. (12 V)	
Dry weight		409 kg (902 lbs.)		
Drive system	Transmission	Type	Hydrostatic	
		Speed	2 speed shifts	
	Reverser		Switching the direction of flow delivered from the variable pump	
	Differential type	Front	N/A	
		Rear	Hydraulic	
	Final drive	Front	Cam motor	
Rear		Cam motor		
Vibration system	Power transmission type		Hydraulic	
	Vibrator type		Variable eccentric shaft	
Brake system	Service brake		Dynamic brake through hydrostatic drive system (F-N-R lever)	
	Secondary brake (Emergency brake)		Hydrostatic + Spring applied hydraulically released type (Brake pedal)	
	Parking brake		Spring applied hydraulically released type (Panel button)	
Steering system	Power transmission type		Hydraulic	
	Steering type		Articulated	
Drum and tyres	Use	Front	Tyres / Vibrate and drive / 3pcs.	
		Rear	Tyres / Vibrate and drive / 4pcs.	
	Suspension type	Front	Rubber isolation	
		Rear	Rubber isolation	
Sprinkler system	Water spray type		Pressurized	
	Liquid spray type		Pressurized	

2. TABLE OF STANDARD VALUES

2-1. Engine

Item		Standard value		Remarks
Engine model		KUBOTA V3800-CR-TI-EV03		
Rated output		81.8 kW (110 HP)		
Max. no-load rotational speed		2,400 min ⁻¹		
Min. no-load rotational speed		1,000 min ⁻¹		
Cylinder head tightening torque		98.1 to 107 N·m (72.4 to 79.5 lbf·ft)		
Intake manifold tightening torque		18 to 20 N·m (13 to 15 lbf·ft)		
Exhaust manifold tightening torque		30 to 34 N·m (22 to 25 lbf·ft)		
Fan belt tension		10 to 12 mm (0.4 to 0.5 in.)		When midpoint of belt pressed at 59 to 67 N (13 to 15 lbf)
Valve clearance	Intake	0.23 to 0.27 mm (0.009 to 0.010 in.)		
	Exhaust	0.23 to 0.27 mm (0.009 to 0.010 in.)		
Compression pressure		3.09 to 3.28 MPa (448 to 476 psi)		200 min ⁻¹

2-2. Propulsion

Item		Standard value		Remarks
Travel speed (Forward/reverse)	1st	0 to 6 km/h (0 to 3.7 mph)		
	2nd	0 to 12 km/h (0 to 7.5 mph)		

2-3. Hydraulic System

Item		Standard value		Remarks	
Propulsion	High pressure relief valve pressure setting		40 MPa (5,800 psi)		
	Pressure limiter valve pressure setting		35 MPa (5,075 psi)		
	Charge pressure relief valve pressure setting		2.4 MPa (348 psi)		
	Brake release pressure		1.4 to 3.0 MPa (203 to 435 psi)		
	Motor drainage		6.6 L/min (1.7 gal./min)		
Vibration	High pressure relief valve setting		17.2 MPa (2,494 psi)		
	Motor drainage	Front	5.6 L/min (1.5 gal./min)		
		Rear	2.6 L/min (0.7 gal./min)		
Steering oil pressure		17.4 MPa (2,523 psi)		(orbitrol relief pressure + charge relief pressure)	

2-4. Steering

Item	Standard value	Remarks
Play in steering wheel	5 to 10 mm (0.2 to 0.4 in.)	Steering wheel circumference
	0.5 mm (0.02 in.) or less	Steering column shaft direction

2-5. Brakes

Item	Standard value	Remarks
Clearance between brake pedal and floorboard (as released)	128 mm (5.0 in.) Note 1: See dimensions	 <p>SW880-02001</p>
Clearance between brake pedal and floorboard (when pressed down)	71 mm (2.8 in.) Note 2: See dimensions	

2-6. Capacities

Item	Standard value	Remarks
Engine oil pan	13 L (3.4 gal.)	
Fuel tank	130 L (34.3 gal.)	
Coolant	18 L (4.8 gal.)	
Hydraulic oil tank	90 L (23.8 gal.)	
Vibrator case	Front	3.2 L (0.85 gal.)
	Rear	2.5 L × 2 (0.66 gal. × 2)
Water spray tank	Front	280 L (74.0 gal.)
	Rear	450 L (118.9 gal.)
Liquid spray tank	19 L (5.0 gal.)	
DEF tank	20 L (5.3 gal.)	

3. FUEL AND LUBRICANTS SPECIFICATION

3-1. Rating

Lubricant	Service classification	Ambient temp. and applicable viscosity rating			Applicable standards
		-15 to 30°C (5 to 86°F) Cold	0 to 40°C (32 to 104°F) Moderate	15 to 55°C (59 to 131°F) Tropical	
Engine oil	API grade CJ-4	SAE10W-30	SAE10W-30	SAE10W-30	MIL-L-2104B
Gear oil	API grade GL5	SAE80W-90	SAE90	SAE140	MIL-L-2105
Hydraulic oil	Anti wear	ISO-VG32 Over VI 140	ISO-VG46 Over VI 140	ISO-VG68 Over VI 110	ISO-3448
Grease	Lithium type extreme pressure				NLGI-2
Fuel	Diesel oil				ASTM D975-2D
DEF	ISO22241-1 or AUS32				

3-2. Recommended Lubricants

Lubricant Oil company	Engine oil API-CJ4	Gear oil API GL 5	Hydraulic oil ISO-VG 46	Grease (NLGI-2)
CHEVRON	DELO 400 LE	RPM Universal Gear Lubricants	Rando HDZ 46	Martifak EP 2
BP	—	BP Energear HYPO-U	Bartran HV 46	BP Energrease LS-EP 2
CASTROL	Tection Extra	EXP Gear OILS	Castrol Hyspin AWH 46	Castrol Spheerol ELP 2
EXXON MOBIL	Mobil Delvac 1 ESP	Mobilube HD	Mobil DTE 10 Excel 46	Mobilux EP 2
SHELL	Shell Rimula R4 L	Shell Spirax S2 A 90	Shell Tellus S2V 46	Shell Alvania Greases EP 2

4. TIGHTENING TORQUE CHART

N·m	(lbf·ft)
-----	----------

	Nominal Dia.	Pitch	Strength Classification							
			6.8		8.8		10.9		12.9	
Metric coarse screw	5	0.8	4.9	(3.6)	5.9	(4.4)	7.8	(5.8)	7.8	(5.8)
	6	1.0	7.8	(5.8)	9.8	(7.2)	13	(9.6)	13	(9.6)
	8	1.25	17	(13)	23	(17)	31	(23)	31	(23)
	10	1.5	39	(29)	49	(36)	59	(44)	59	(44)
	12	1.75	69	(51)	78	(58)	108	(80)	108	(80)
	14	2.0	98	(72)	127	(94)	167	(123)	167	(123)
	16	2.0	157	(116)	196	(145)	265	(195)	265	(195)
	18	2.5	196	(145)	245	(181)	343	(253)	343	(253)
	20	2.5	294	(217)	392	(289)	539	(398)	539	(398)
	22	2.5	441	(325)	539	(398)	686	(506)	686	(506)
	24	3.0	539	(398)	637	(470)	883	(651)	883	(651)
	27	3.0	785	(579)	981	(724)	1324	(977)	1324	(977)
30	3.5	1079	(796)	1324	(977)	1765	(1302)	1765	(1302)	
Metric fine screw	10	1.25	39	(29)	49	(36)	69	(51)	69	(51)
	12	1.25	69	(51)	88	(65)	118	(87)	118	(87)
	14	1.5	108	(80)	137	(101)	186	(137)	186	(137)
	16	1.5	167	(123)	206	(152)	284	(209)	284	(209)
	18	1.5	245	(181)	294	(217)	392	(289)	392	(289)
	20	1.5	343	(253)	441	(325)	588	(434)	588	(434)
	22	1.5	490	(361)	588	(434)	785	(579)	785	(579)
	24	2.0	588	(434)	735	(542)	981	(724)	981	(724)
	27	2.0	834	(615)	1030	(760)	1422	(1049)	1422	(1049)
30	2.0	1177	(868)	1422	(1049)	1961	(1446)	1961	(1446)	

ENGINE AND CONTROLS

1. ENGINE

1-1. Engine Mount

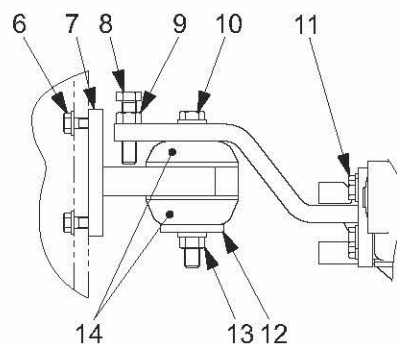
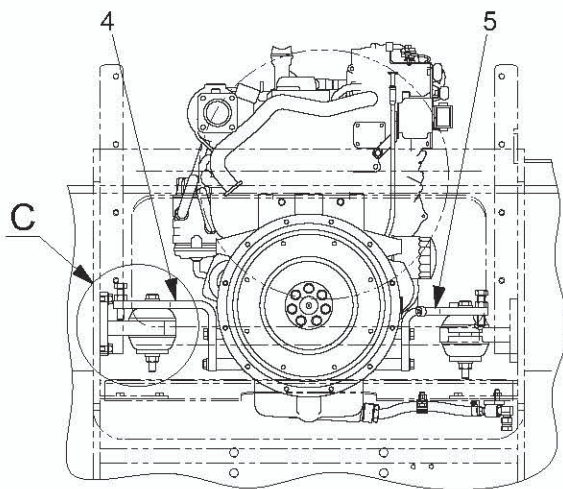
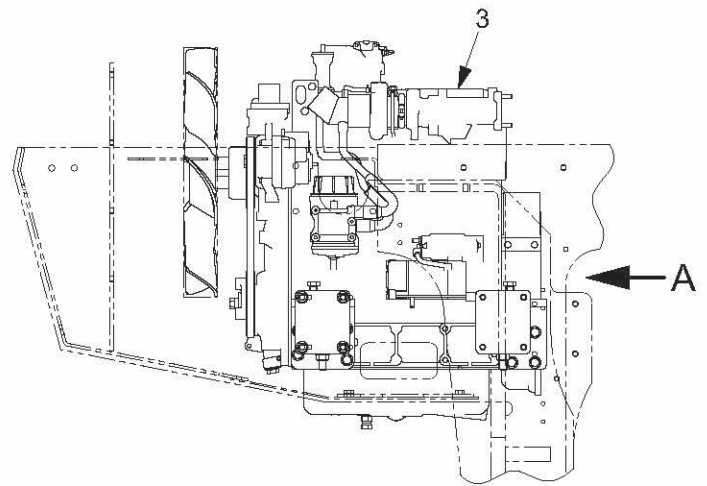
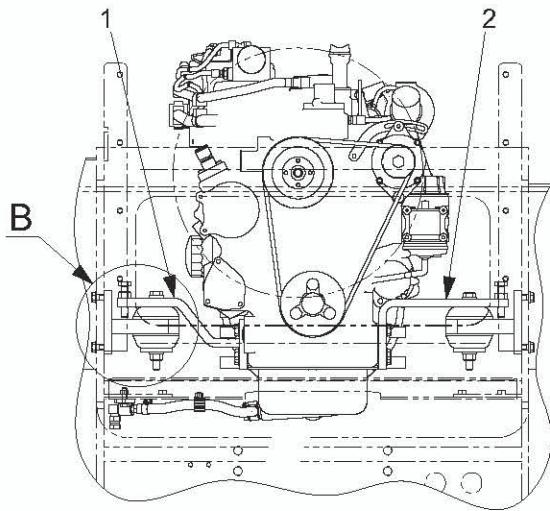

DETAIL B

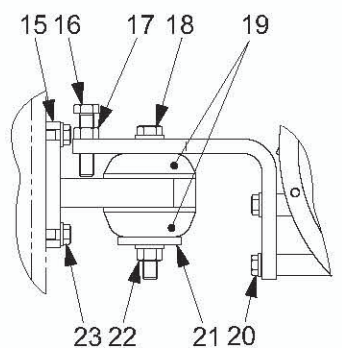

DETAIL C

VIEW A

0539-01805-0-11031-A

- | | | |
|-------------------|----------------------------|----------------------------|
| (1) Bracket | (9) Nut : M16 | (17) Nut : M16 |
| (2) Bracket | (10) Bolt : M16×160 | (18) Bolt : M16×160 |
| (3) Engine | (11) Bolt : M12× 35 P=1.25 | (19) Damper |
| (4) Bracket | (12) Plate | (20) Bolt : M12× 35 P=1.25 |
| (5) Bracket | (13) Nut : M16 | (21) Plate |
| (6) Bolt : M12×35 | (14) Damper | (22) Nut : M16 |
| (7) Hanger | (15) Hanger | (23) Bolt : M12× 35 |
| (8) Bolt : M16×70 | (16) Bolt : M16× 70 | |



- | | |
|---|---|
| (6) Bolt M12×35 : 108 N·m (80 lbf·ft) | (20) Bolt M12×35 P=1.25 : 118 N·m (87 lbf·ft) |
| (11) Bolt M12×35 P=1.25 : 118 N·m (87 lbf·ft) | (22) Nut M16 : 265 N·m (195 lbf·ft) |
| (13) Nut M16 : 265 N·m (195 lbf·ft) | (23) Bolt M12×25 : 108 N·m (80 lbf·ft) |

1-2. Engine Exterior

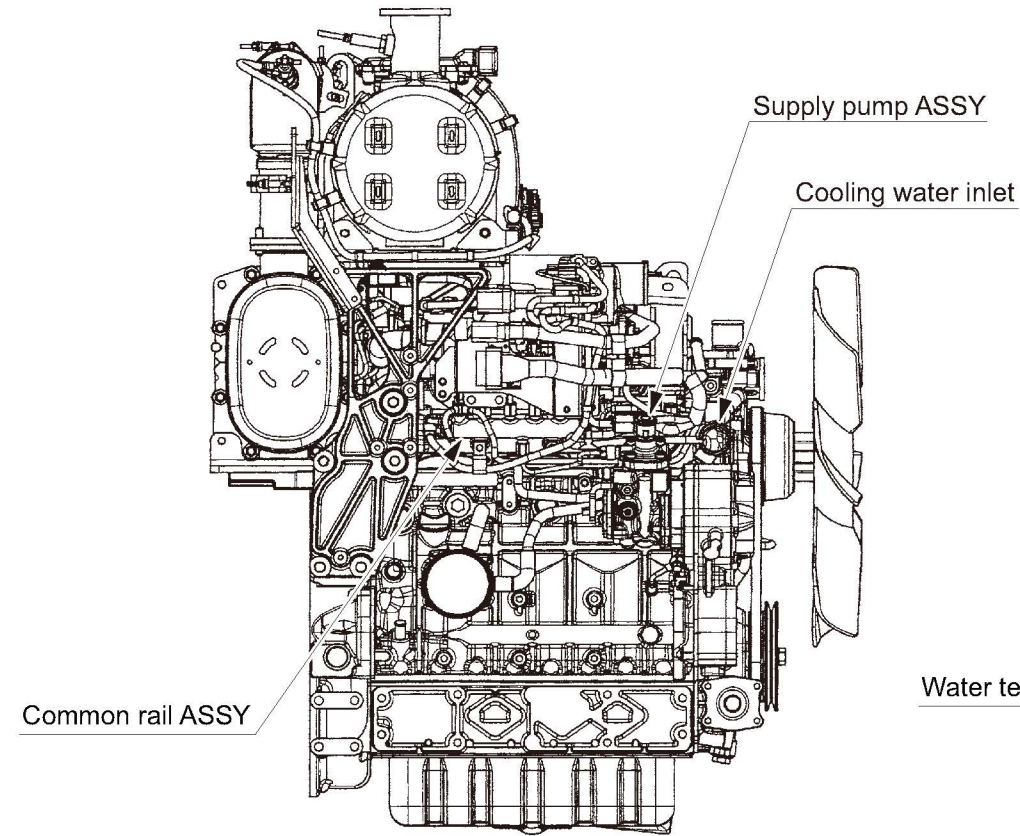

VIEW A

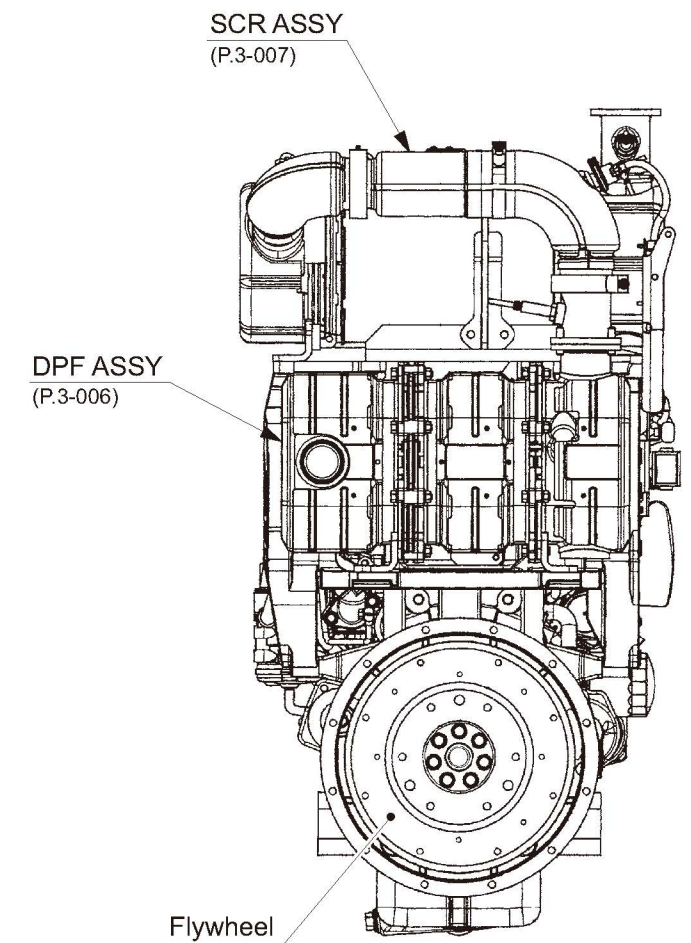
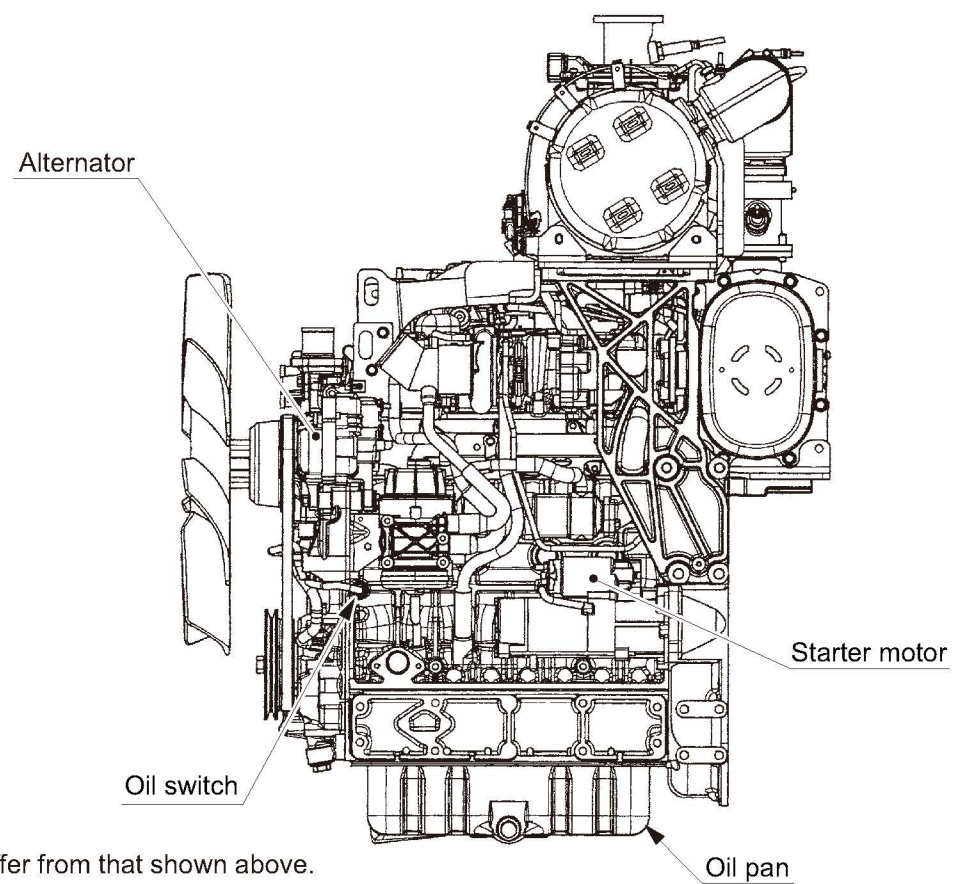
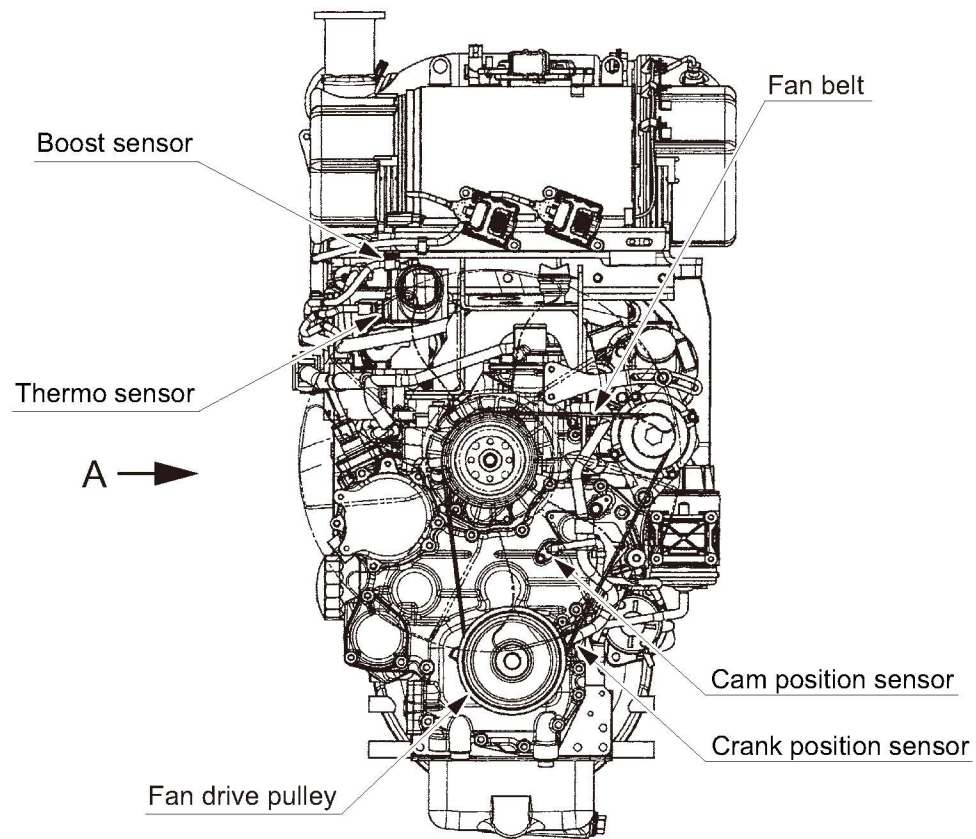
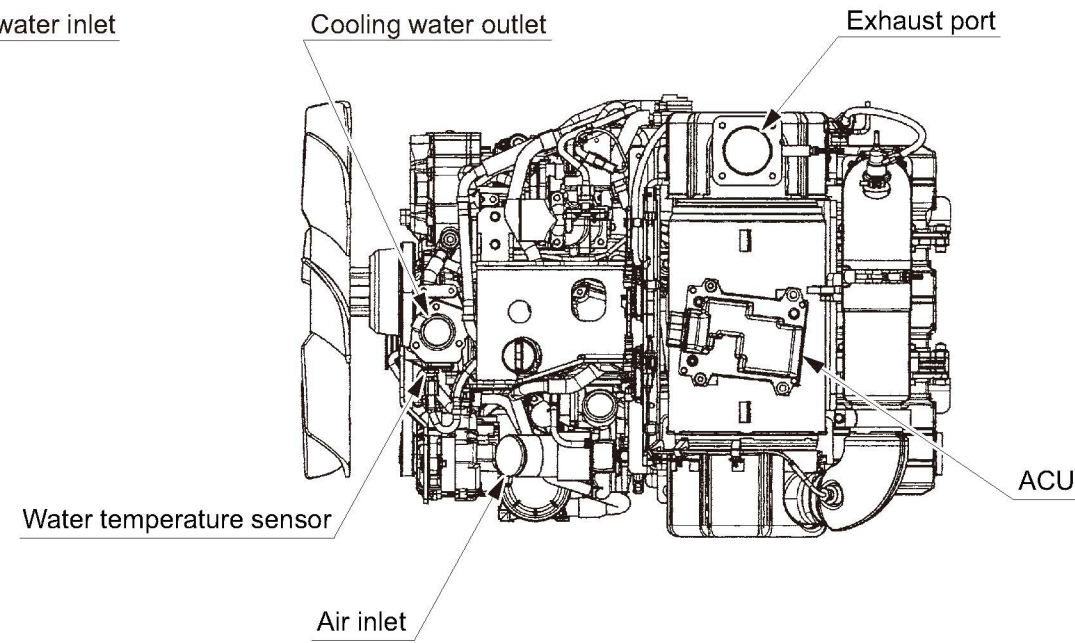

* The actual equipment may differ from that shown above.

2. FUEL SYSTEM

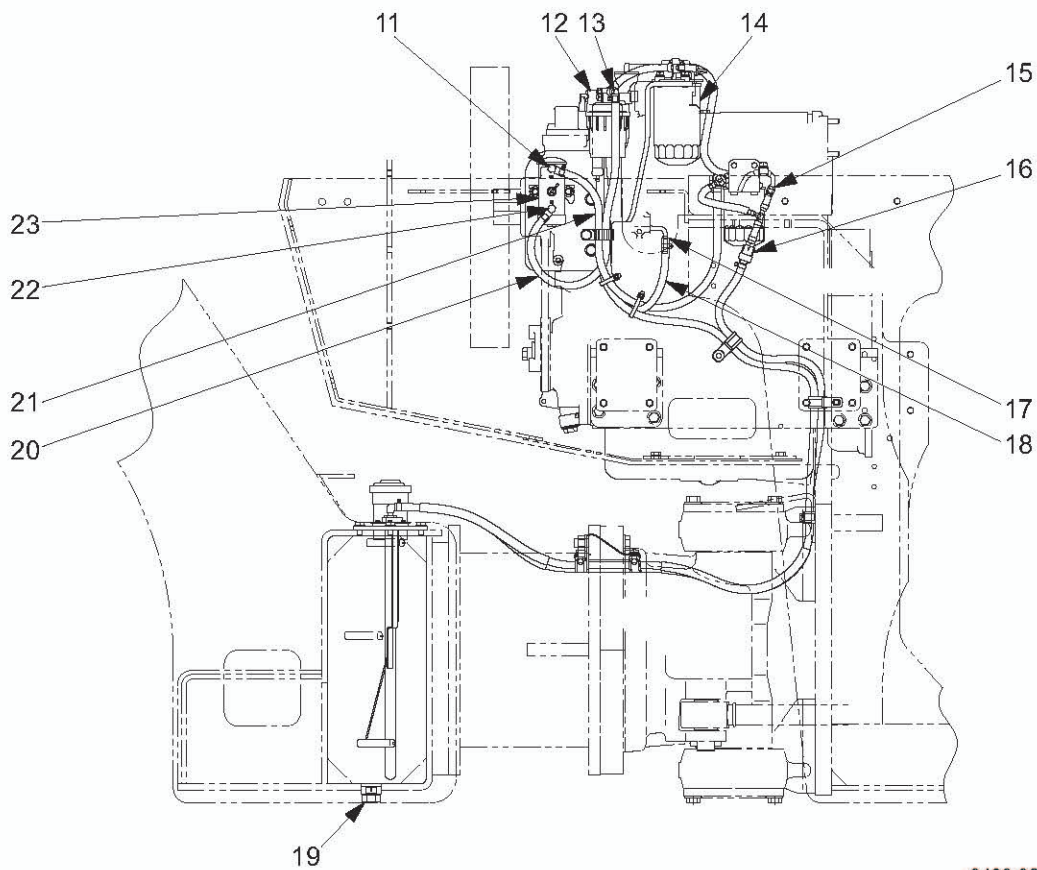
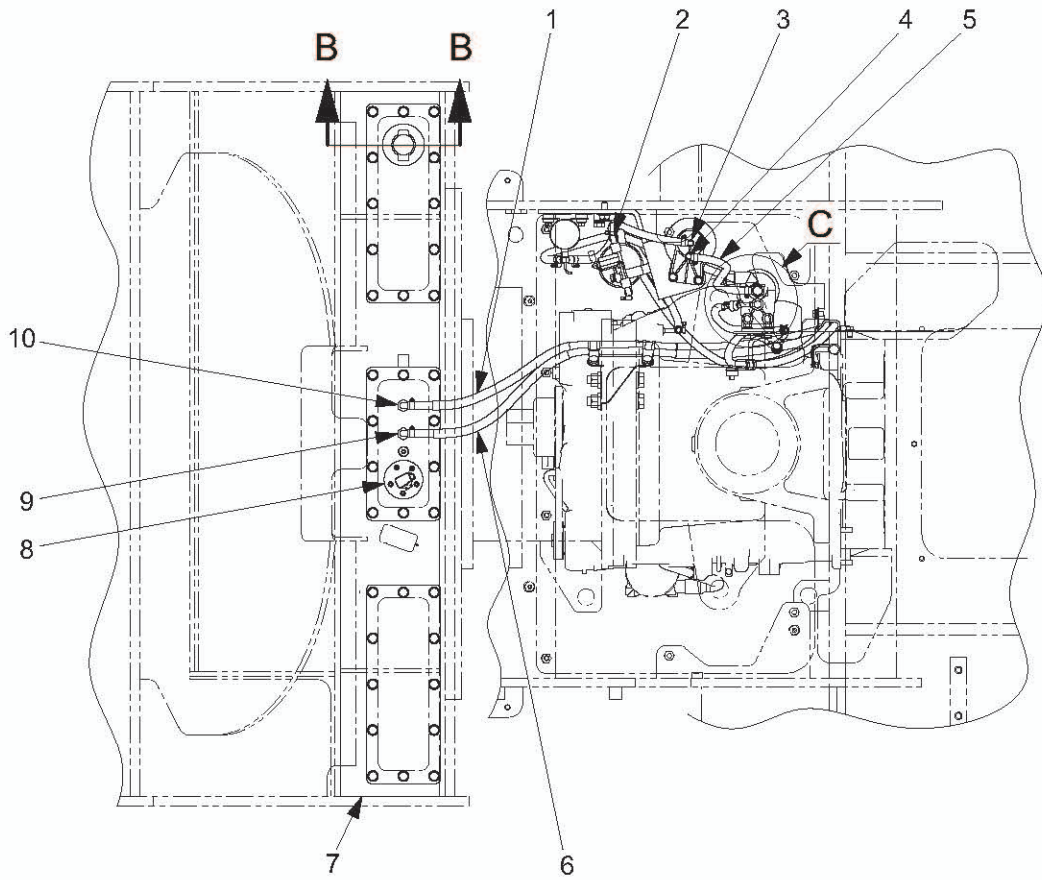

0439-02801-0-10032-C

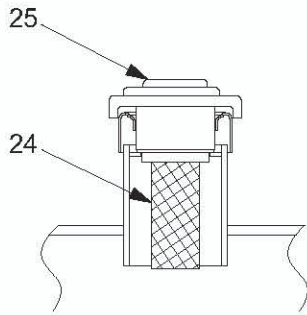

SECTION B-B

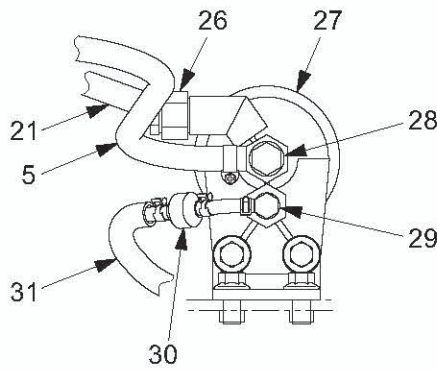

DETAIL C

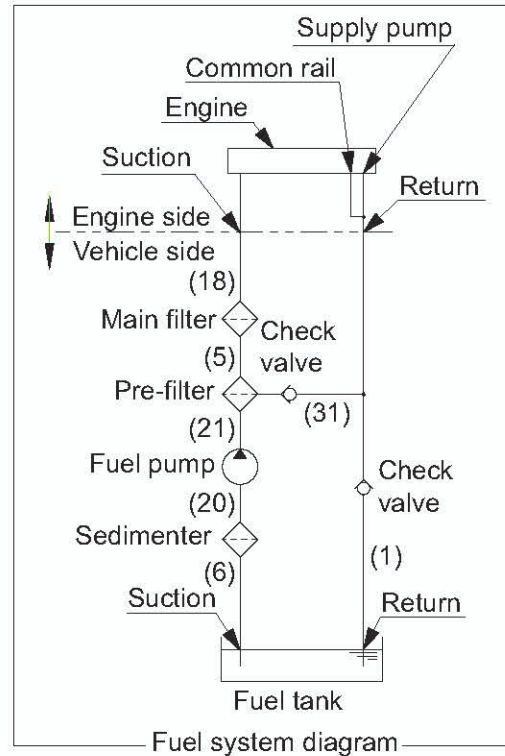

Fuel system diagram

0439-02801-0-10032-C

- | | |
|-------------------------|-----------------------------|
| (1) Hose (15 → 10) | (17) Suction (engine) |
| (2) IN (sedimenter) | (18) Hose (3 → 17) |
| (3) OUT (main filter) | (19) Drain plug (fuel tank) |
| (4) IN (main filter) | (20) Hose (13 → 22) |
| (5) Hose (28 → 4) | (21) Hose (11 → 26) |
| (6) Hose (9 → 2) | (22) IN (fuel pump) |
| (7) Fuel tank | (23) Fuel pump |
| (8) Fuel gauge unit | (24) Strainer |
| (9) Suction (fuel tank) | (25) Filler cap |
| (10) Return (fuel tank) | (26) IN (pre-filter) |
| (11) OUT (fuel pump) | (27) Pre-filter |
| (12) Sedimenter | (28) OUT (pre-filter) |
| (13) OUT (sedimenter) | (29) Vent (pre-filter) |
| (14) Main filter | (30) Check valve |
| (15) Return (engine) | (31) Hose (30 → 16) |
| (16) Check valve | |

• Arrow "→" symbols show the hose connection and direction of the flow of the fuel.

3. EXHAUST SYSTEM

3-1. Exhaust System

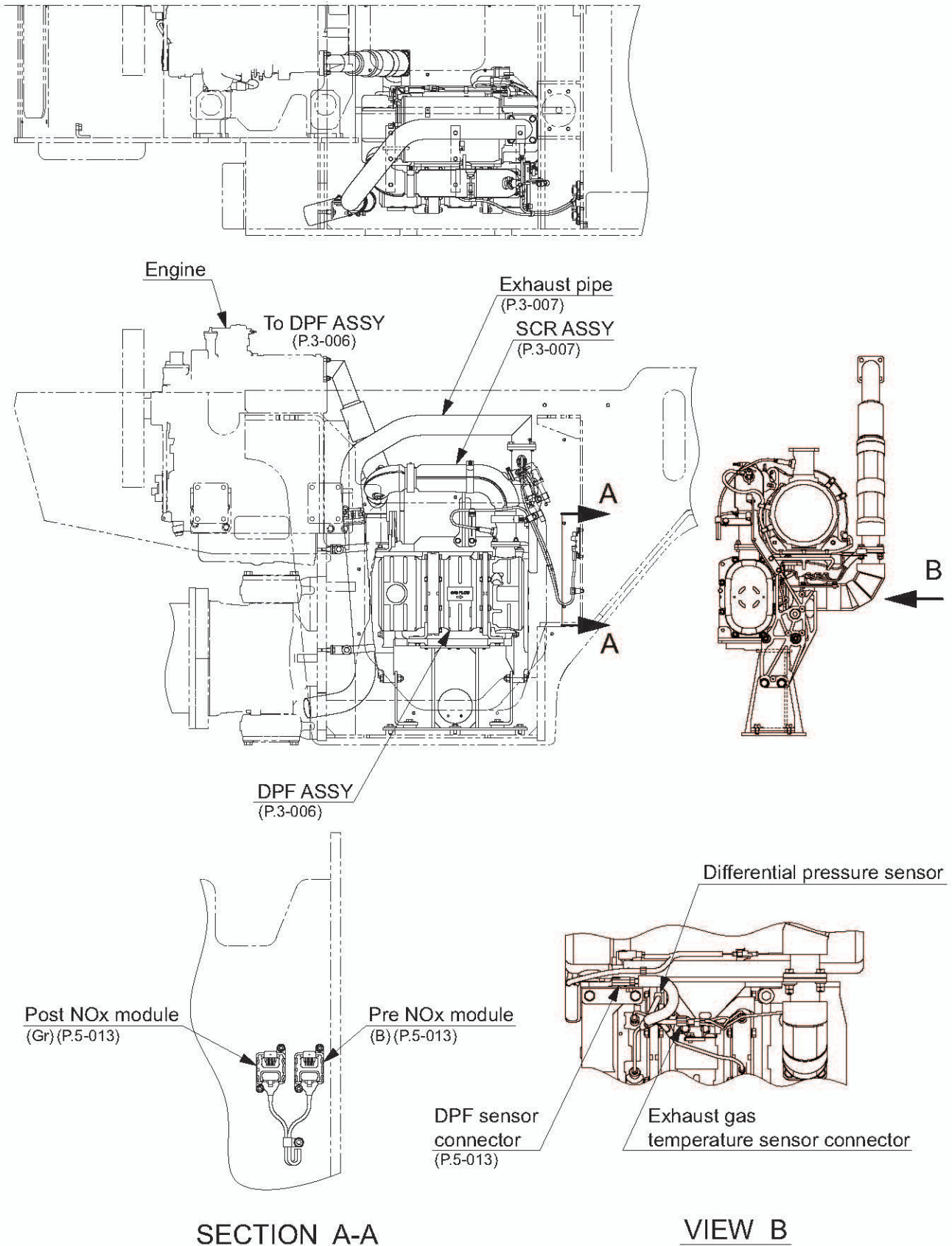

3-1-1. DPF ASSY

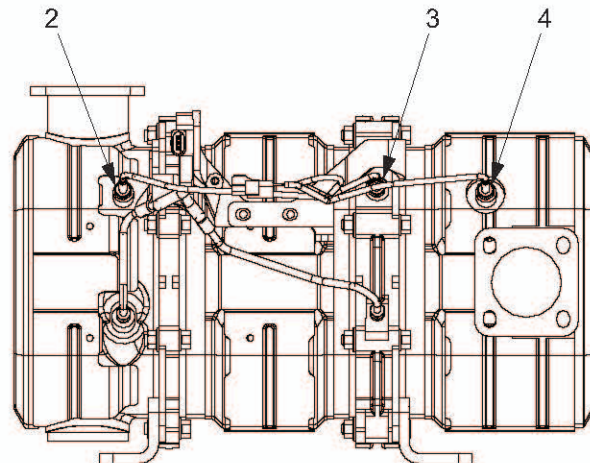
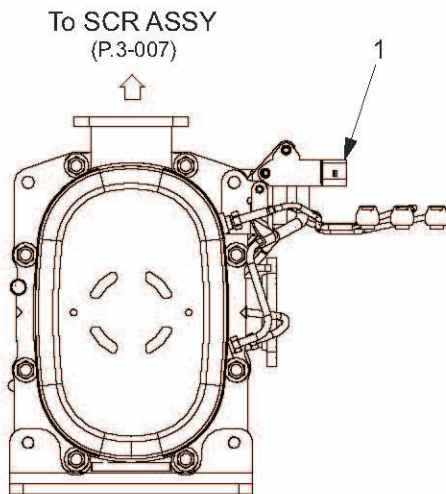
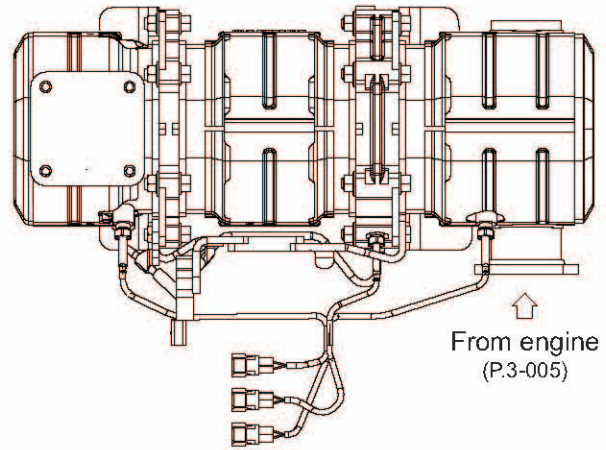

SW774-03004

- (1) Differential pressure sensor
- (2) Exhaust gas temperature sensor T2
- (3) Exhaust gas temperature sensor T1
- (4) Exhaust gas temperature sensor T0

3-1-2. SCR ASSY

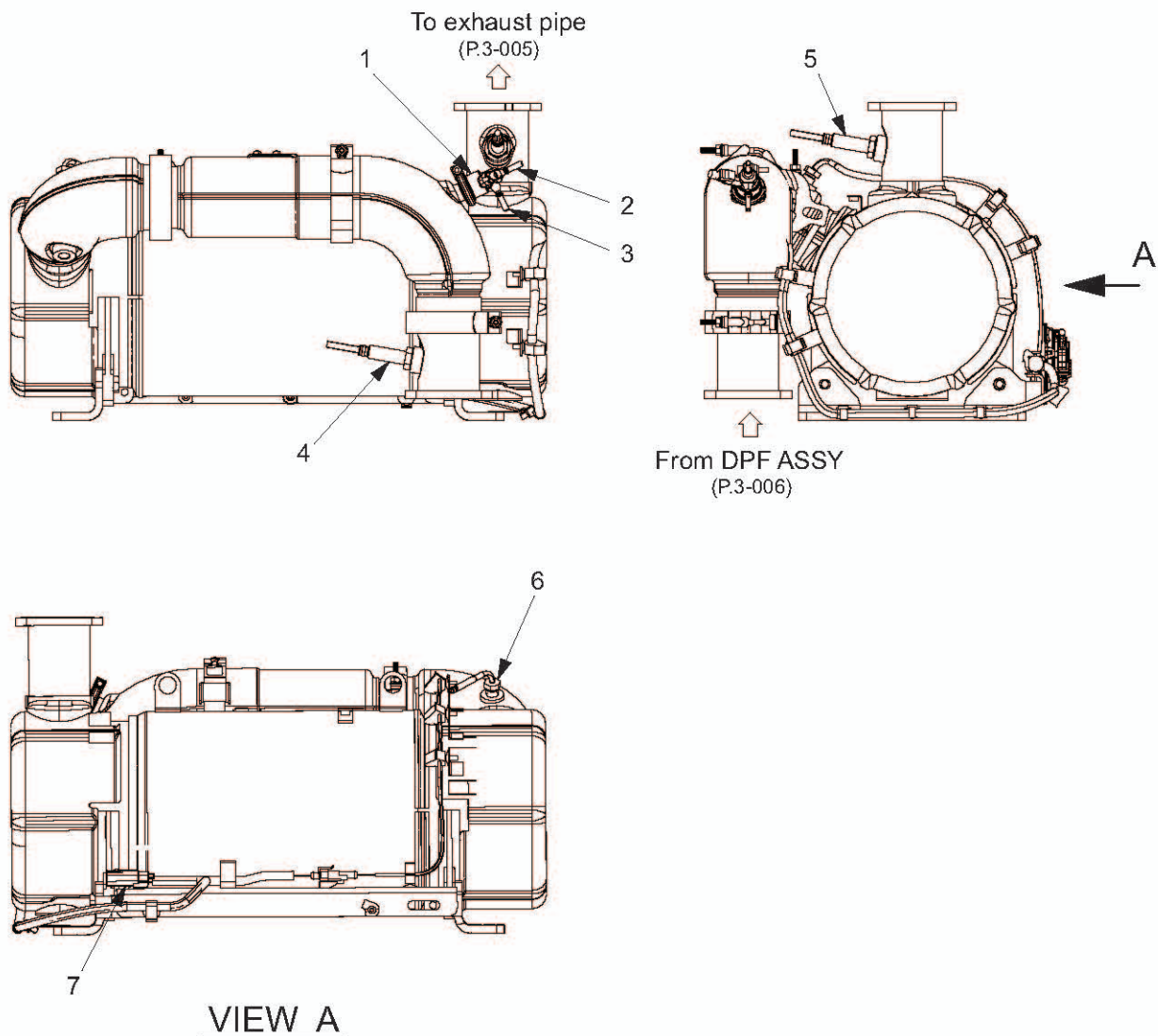

- (1) DEF injector
- (2) Outlet (DEF injector) (P.3-008)
- (3) Inlet (DEF injector) (P.3-008)
- (4) Pre NOx sensor
- (5) Post NOx sensor
- (6) SCR temperature sensor
- (7) DEF injector and SCR temperature sensor connector (P.5-013)

SW774-03005

3-2. Urea Piping

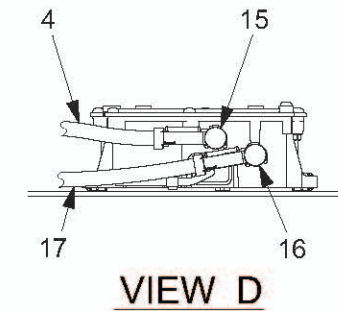
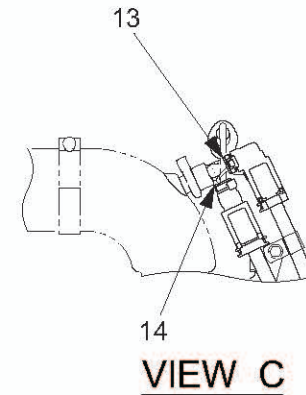
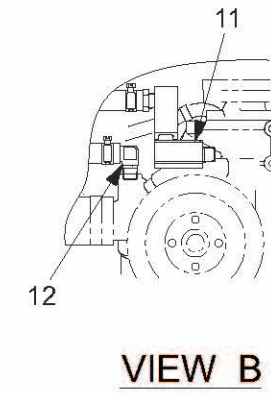
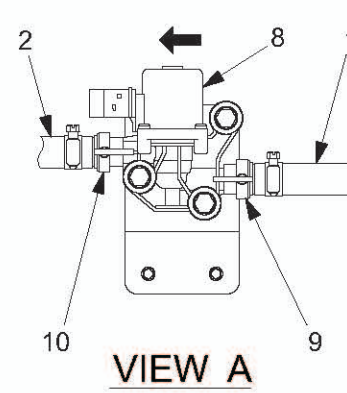
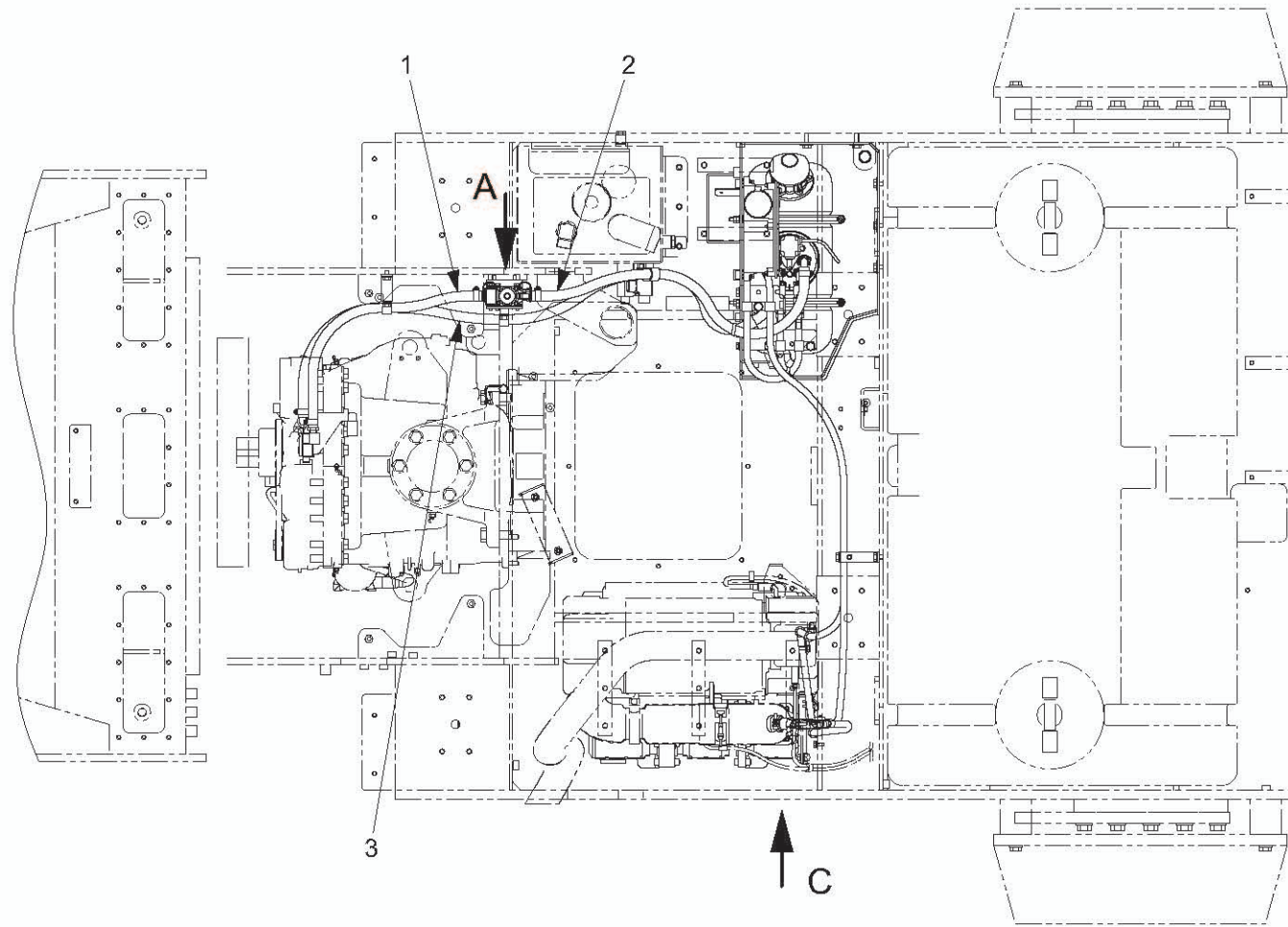

- (1) Hose (11 → 9)
- (2) Hose (10 → 21)
- (3) Hose (18 → 12)
- (4) Hose (15 ⇒ 14) [Suction tube heater **SUC**] (P.5-013)
- (5) DEF pump
- (6) DEF tank
- (7) Hose (13 ⇒ 19) [Return tube heater **RET**] (P.5-013)
- (8) DEF tank heating valve (P.5-011)
- (9) Coolant inlet (heating valve)
- (10) Coolant outlet (heating valve)
- (11) Coolant outlet (engine)
- (12) Coolant inlet (engine)
- (13) Outlet (DEF injector) (P.3-007)
- (14) Inlet (DEF injector) (P.3-007)
- (15) Discharge (DEF pump) (P.3-009)
- (16) Suction (DEF pump) (P.3-009)
- (17) Hose (20 ⇒ 16) [Delivery tube heater **DEL**] (P.5-013)
- (18) Coolant outlet (DEF tank) (P.3-010)
- (19) Return (DEF tank) (P.3-010)
- (20) Outlet (DEF tank) (P.3-010)
- (21) Coolant inlet (DEF tank) (P.3-010)

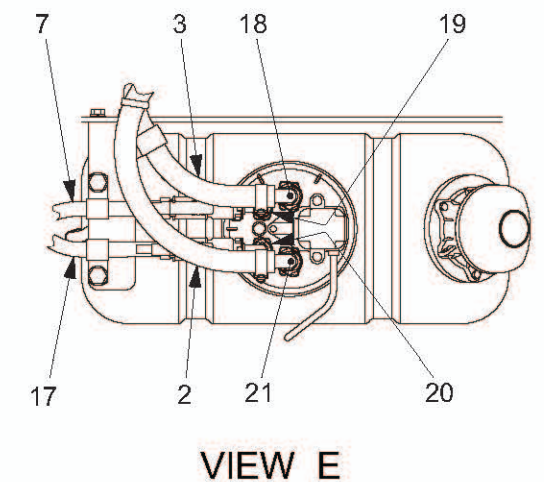
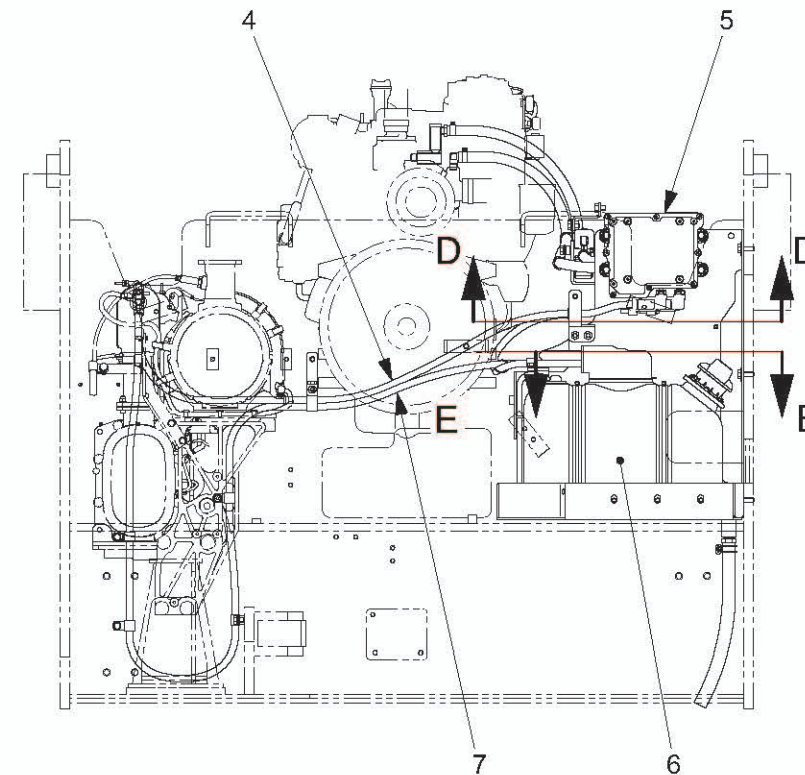
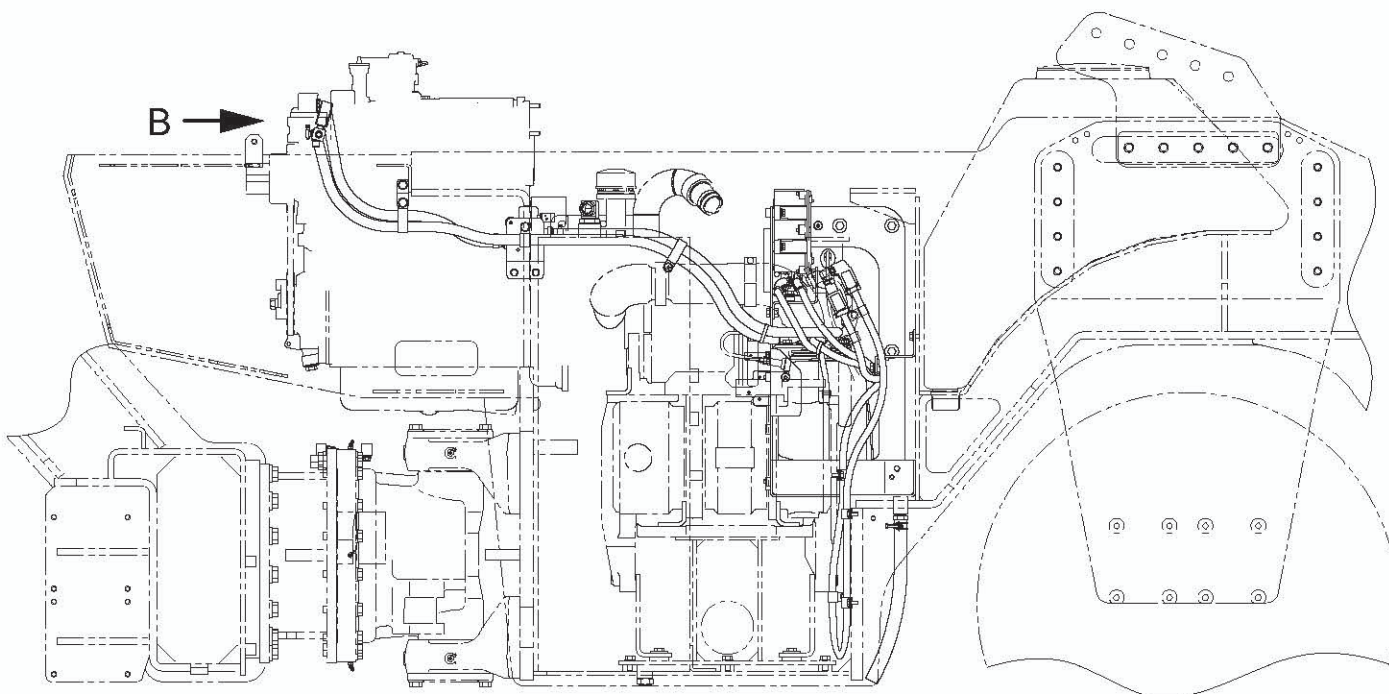

• Arrow "⇒" symbols show the hose connection and the direction of the flow of the DEF.
 • Arrow "→" symbols show the hose connection and the direction of the flow of the coolant.

3-2-1. DEF pump

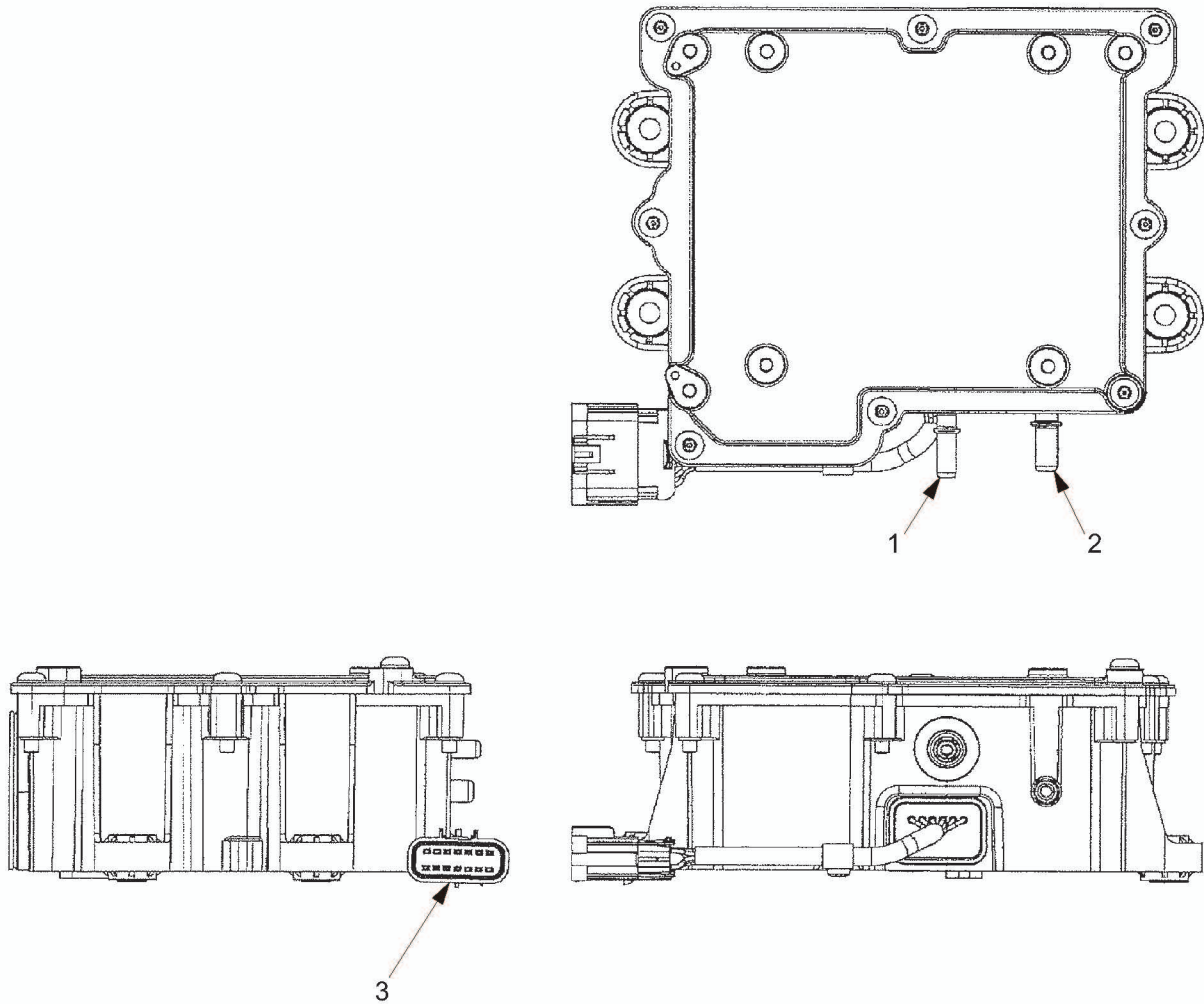

SW774-03002

- (1) DEF outlet port (P.3-008)
- (2) DEF inlet port (P.3-008)
- (3) DEF pump connector (P.5-013)

Specification

- Rated voltage : 12 V

3-2-2. DEF tank

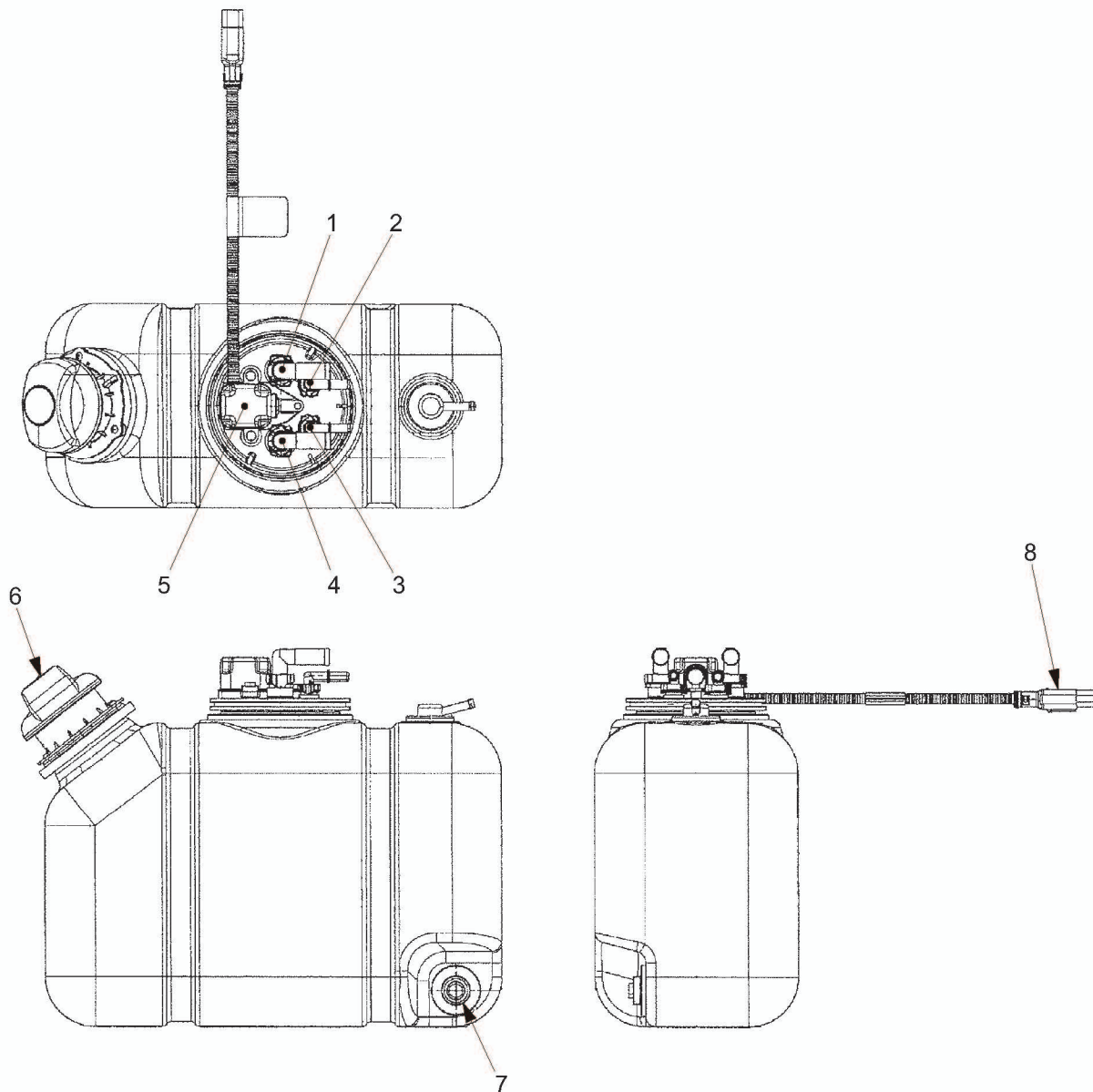

SW774-03003

- (1) Coolant inlet port (P.3-008)
- (2) DEF outlet port (P.3-008)
- (3) DEF return port (P.3-008)
- (4) Coolant outlet port (P.3-008)
- (5) DEF tank sensor
- (6) Filler cap
- (7) Plug (drain)
- (8) DEF tank sensor connector (P.5-013)

Specification

- Capacity : 20 L (5.28 gal.)

4. CONTROL SYSTEM

4-1. Forward-reverse Control

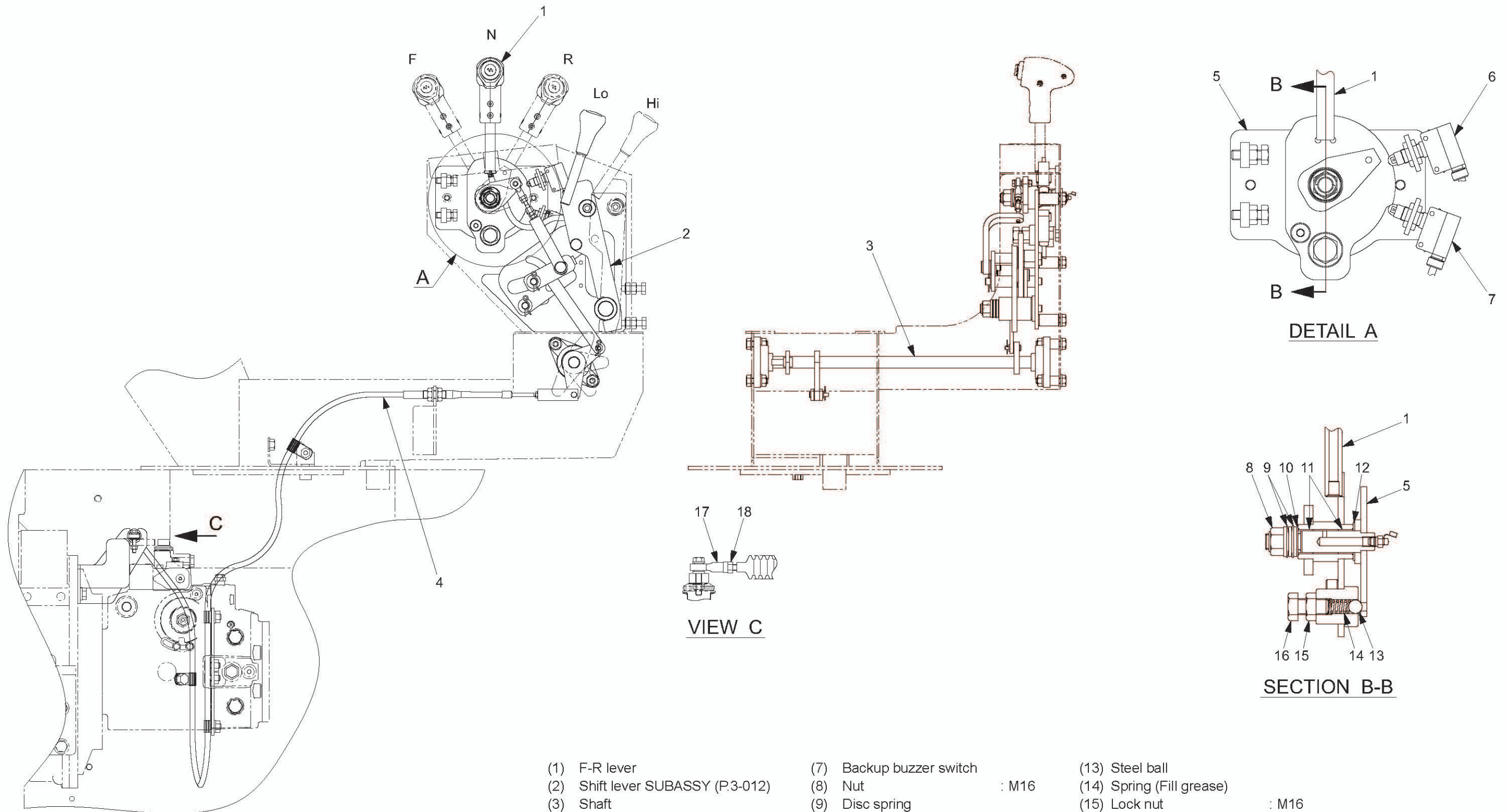

- | | | |
|-----------------------------------|-----------------------------|-----------------------------------|
| (1) F-R lever | (7) Backup buzzer switch | (13) Steel ball |
| (2) Shift lever SUBASSY (P.3-012) | (8) Nut : M16 | (14) Spring (Fill grease) |
| (3) Shaft | (9) Disc spring | (15) Lock nut : M16 |
| (4) Control cable | (10) Washer (Apply grease*) | (16) Bolt : M16×30 |
| (5) Bracket | (11) Bush (Apply grease*) | (17) Rod end (Apply grease) : M 6 |
| (6) F-R lever switch | (12) Washer (Apply grease*) | (18) Lock nut : M 6 |

* : Lithium-based grease

4-1-1. Shift lever SUBASSY

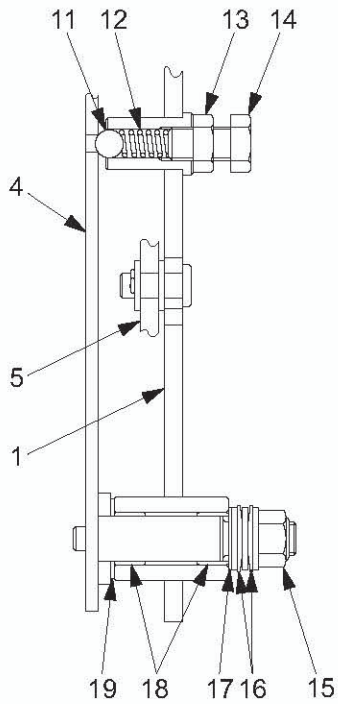

SECTION A-A

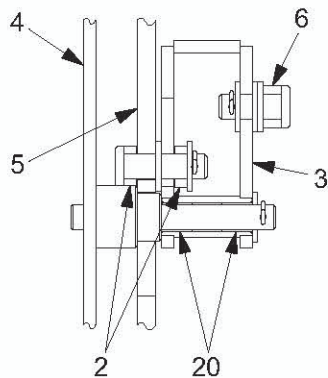
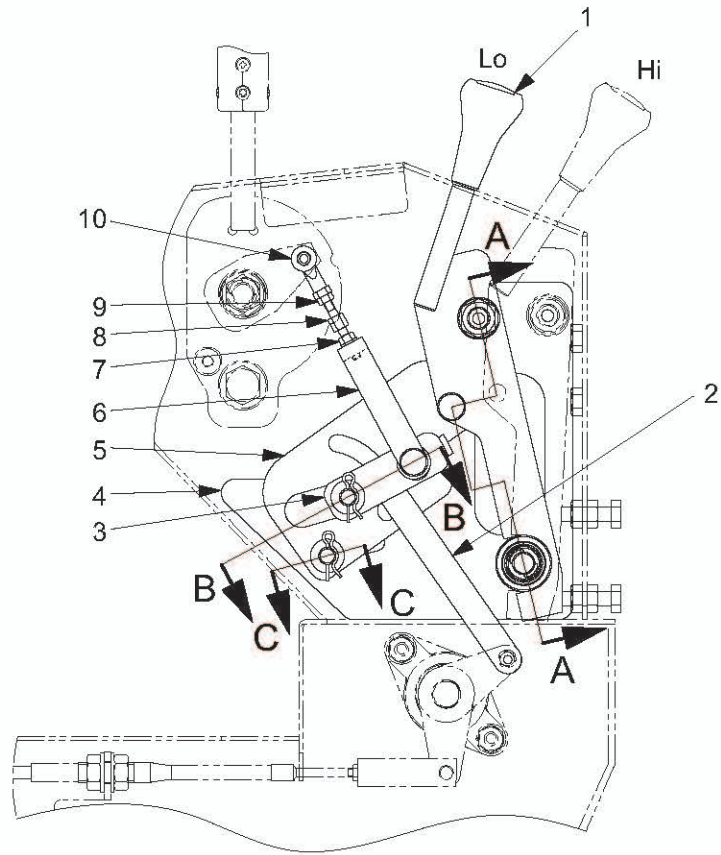

SECTION B-B

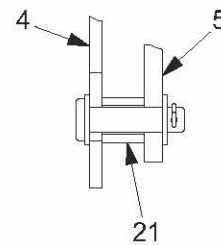

SECTION C-C

0539-12004-1-11034-A

- | | | |
|--------------------------------------|-----------------------------|----------|
| (1) Shift lever | (12) Spring (Fill grease) | |
| (2) Arm | (13) Lock nut | : M16 |
| (3) Arm | (14) Bolt | : M16×30 |
| (4) Base | (15) Nut | : M16 |
| (5) Arm | (16) Disc spring | |
| (6) Arm | (17) Washer (Apply grease*) | |
| (7) Lock nut : M6 | (18) Bush (Apply grease*) | |
| (8) Rod | (19) Washer (Apply grease*) | |
| (9) Lock nut : M6 (left-hand thread) | (20) Bush (Apply grease*) | |
| (10) Rod end : M6 (left-hand thread) | (21) Collar | |
| (11) Steel ball | | |

* : Lithium-based grease

5. PUMP MOUNT

5-1. Pump Mount

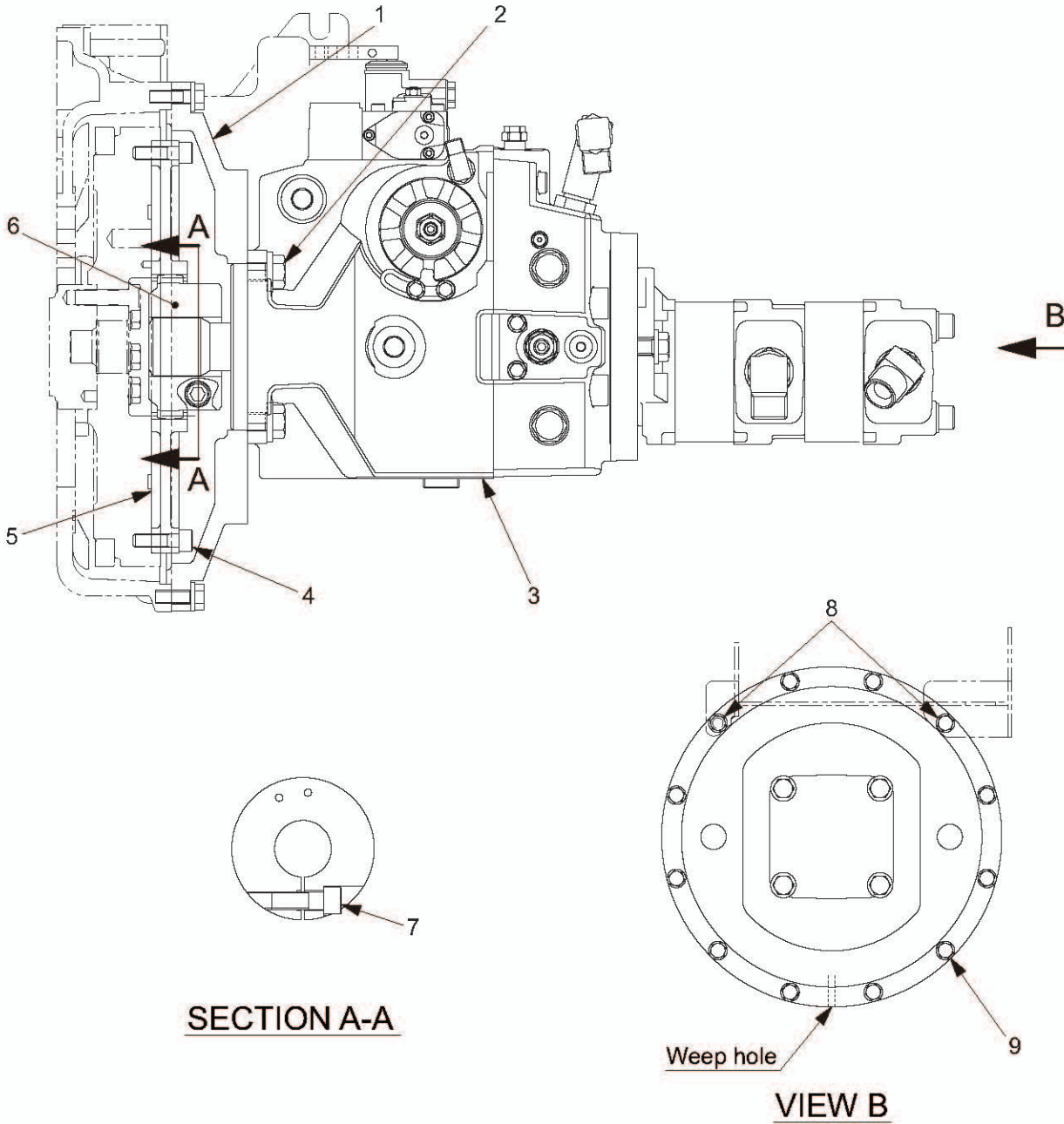

SECTION A-A

VIEW B

0539-36808-0-11094-A

- | | |
|--------------------------|--------------------------|
| (1) Housing | (6) Hub |
| (2) Bolt : M14×40 | (7) Bolt : M12×35 |
| (3) Pump | (8) Bolt : M10×40 P=1.25 |
| (4) Bolt : M10×35 P=1.25 | (9) Bolt : M10×35 P=1.25 |
| (5) Flange | |



- | | | | |
|------------------------|--------------------------|------------------------|------------------------|
| (2) Bolt M14×40 | : 167 N·m (123 lbf·ft) | (8) Bolt M10×40 P=1.25 | : 69 N·m (51 lbf·ft) |
| (4) Bolt M10×35 P=1.25 | : 49 N·m (36 lbf·ft) | (9) Bolt M10×35 P=1.25 | : 69 N·m (51 lbf·ft) |
| (7) Bolt M12×35 | : 86 N·m (63 lbf·ft) | | |

5-1-1. Installation of pump

- When the pump has been removed from the engine for repair or replacement, reinstall it in accordance with the following procedure.

- ① Apply adequate amount of grease to pump (3) and hub (6) splines.
- ② Attach hub (6) to pump (3) aligning it with end surface of shaft.
- ③ Secure hub (6) with bolt (7).



(7) Bolt M12×35 : 86 N·m (63 lbf·ft)

- ④ Position flange (5) as shown in the figure, and secure to flywheel with eight bolts (4).



(4) Bolt M10×35 P=1.25 : 49 N·m (36 lbf·ft)

(NOTICE)

- **Bolt (4) is treated with thread-locking fluid. Use new thread-locking fluid treated bolt for installation.**

- ⑤ Position housing (1) as shown in the figure, and secure to flywheel housing with two bolts (8), ten bolts (9), and washers.



(8) Bolt M10×40 P=1.25 : 69 N·m (51 lbf·ft)
 (9) Bolt M10×35 P=1.25 : 69 N·m (51 lbf·ft)

- ⑥ Engage hub (6) with flange (5).
- ⑦ Secure pump (3) to housing (1) with four bolts (2) and washers.



(2) Bolt M14×40 : 167 N·m (123 lbf·ft)

HYDRAULIC SYSTEMS

1. SYSTEM CIRCUIT DIAGRAM

1-1. Graphic Symbols for Hydraulic Circuits

Basic Symbols

DESCRIPTION	SYMBOL
Lines:	
Main working	
Pilot control	
Drain or bleed	
Lines, joining	
Not connected	
Component outline	
Arrow indicates direction of flow.	
Line with fixed restriction (orifice).	
Test port, pressure measurement.	
Temperature measurement gauge	
Pressure measurement gauge	
Reservoir (vented)	
Filter or strainer	
Heat exchanger, lines indicate flow of coolant.	
Quick disconnect: Connected with mechanically opened checks. Disconnected.	
Sloping arrow through a symbol at 45° indicates that a component can be adjusted or varied.	

Pump, Motors and Cylinders

DESCRIPTION	SYMBOL
Hydraulic pumps:	
Fixed displacement	
Unidirectional	
Bidirectional	
Variable displacement	
Unidirectional	
Bidirectional	
Variable displacement pressure compensated Unidirectional	
Hydraulic Motor:	
Unidirectional	
Bidirectional	
Double acting hydraulic cylinder	
Differential cylinder	
Electric motor	

Valves

DESCRIPTION	SYMBOL
Check valve	
Manual shut off (On-Off)	
Pressure relief	
Flow control, adjustable	
Valve symbols: The basic valve symbol one or more squares with lines representing flow paths and flow conditions between ports.	
Multiple squares indicate a valve with as many distinct positions there are squares providing various flow path options for the fluid. The multiple square moves to represent how flow paths change when the valving element is shifted within the component.	
Valves with infinite positioning between certain limits are symbolized with lines parallel to the squares.	

Methods of Operation

DESCRIPTION	SYMBOL
Spring	
Manual	
Pressure compensated	
Reversing motor	
Pilot pressure: Internal supply	
Remote supply	
Solenoid: Single winding	
Two windings operating in opposite directions.	
Pilot directional valve is actuated by the solenoid.	

1-2. Hydraulic Circuit Diagram

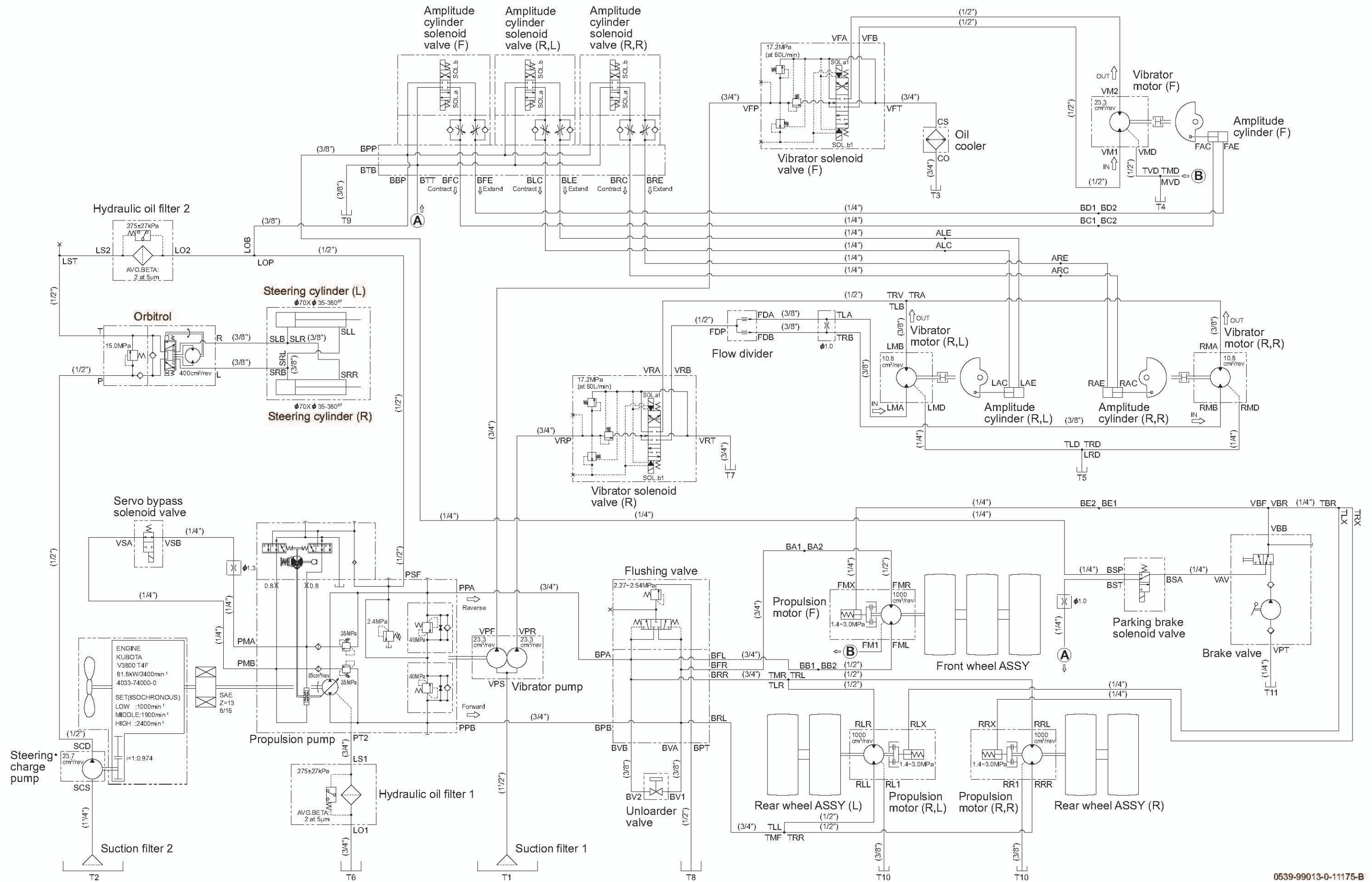

2. PROPULSION HYDRAULIC SYSTEM

2-1. Propulsion Hydraulic Piping

2-1-1. Propulsion hydraulic piping (pump)

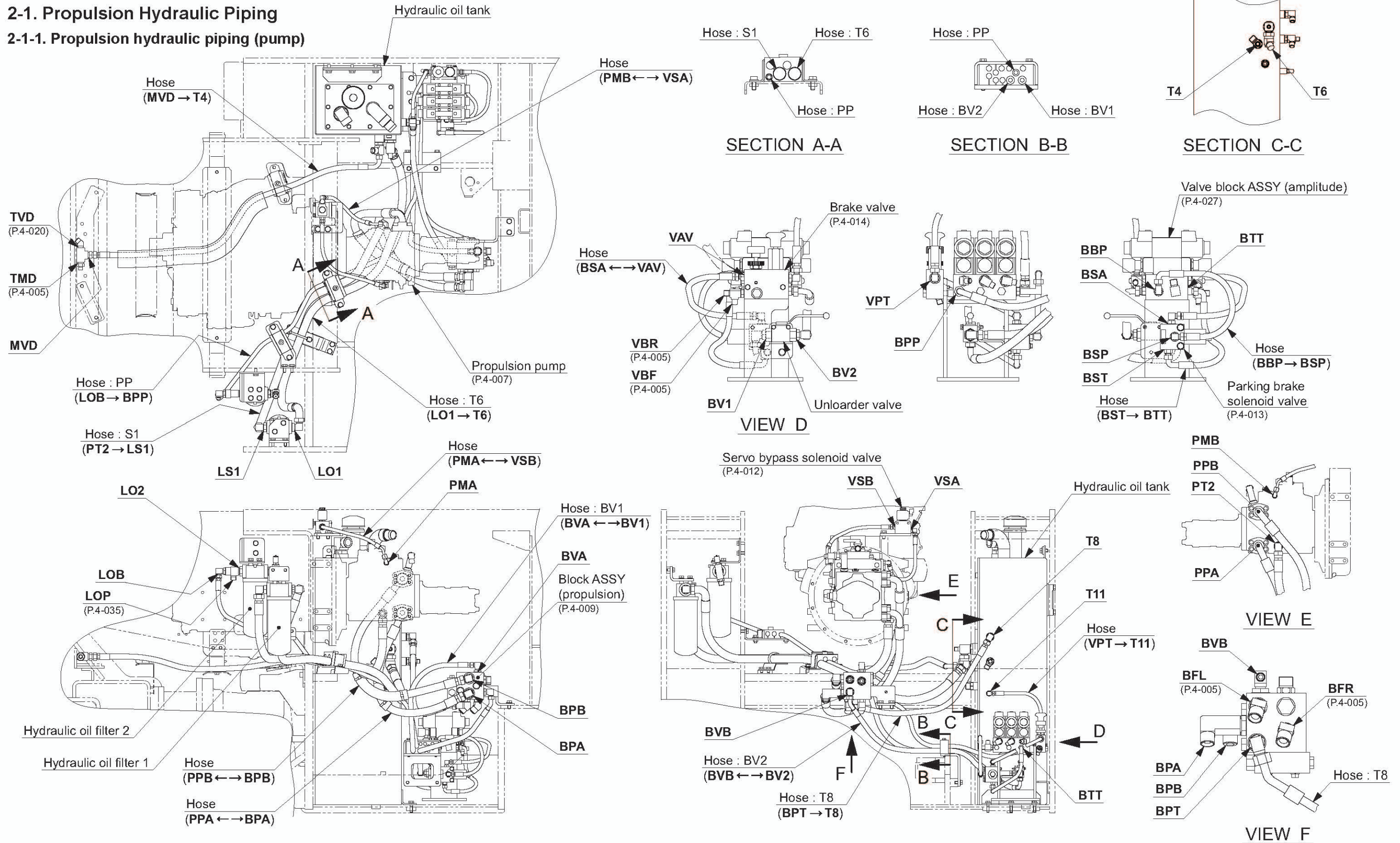

- The letters and numbers in the figure such as "PPA" and "BPA" show each port.
- Arrow " ↔ ; → " symbols show the hose connection and the direction of the flow of the oil.

2-1-2. Propulsion hydraulic piping (motor) (1)

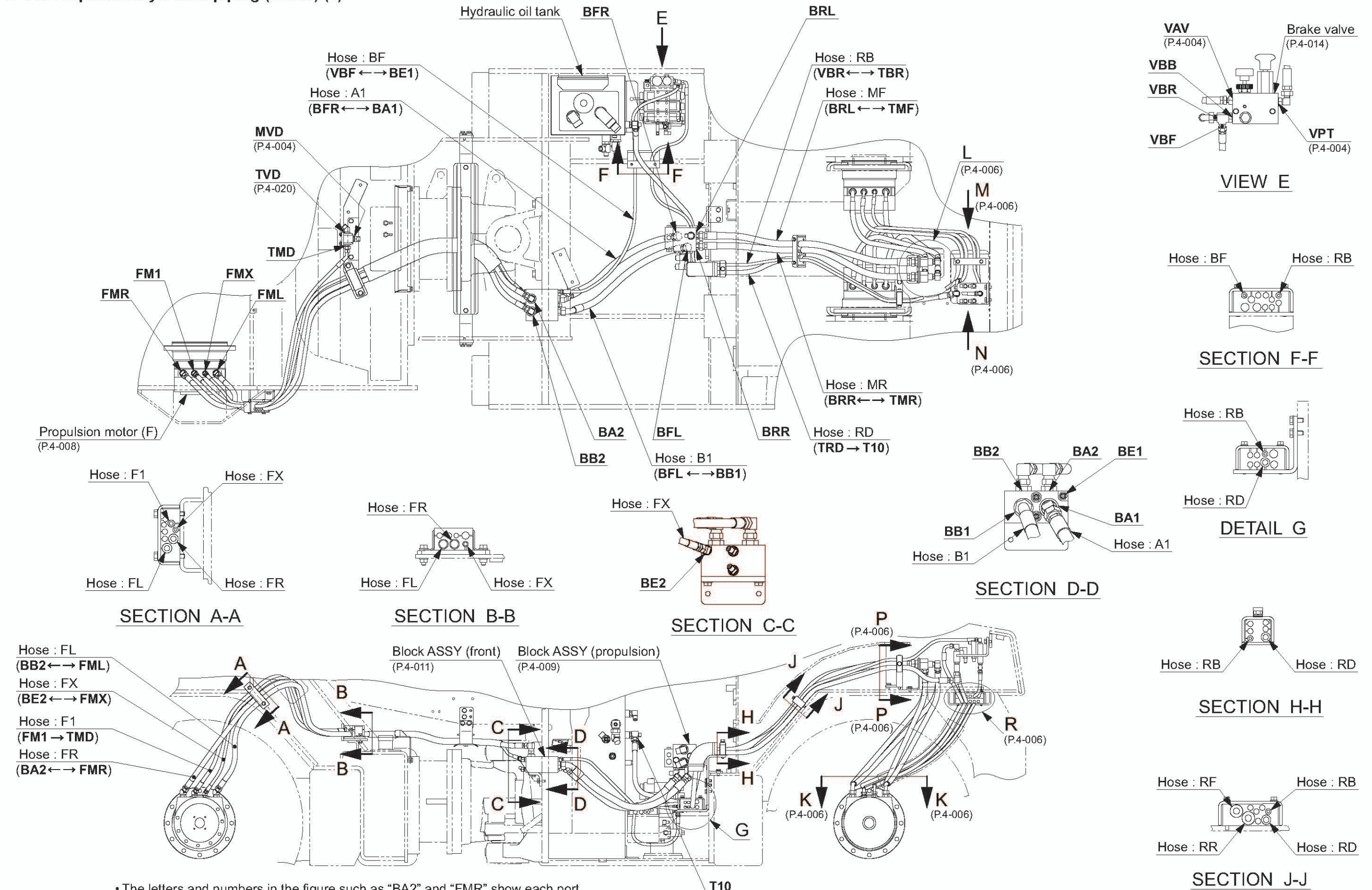

- The letters and numbers in the figure such as "BA2" and "FMR" show each port.
- Arrow " ↔ ; → " symbols show the hose connection and the direction of the flow of the oil.

2-1-3. Propulsion hydraulic piping (motor) (2)

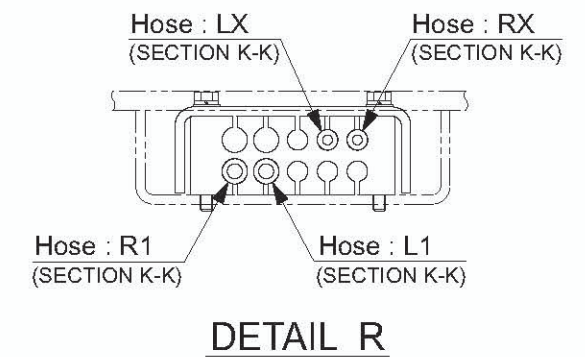
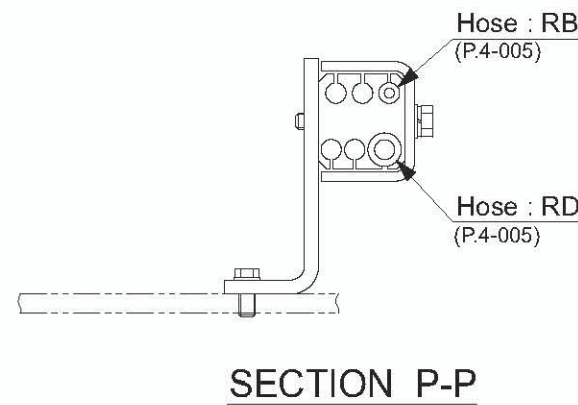
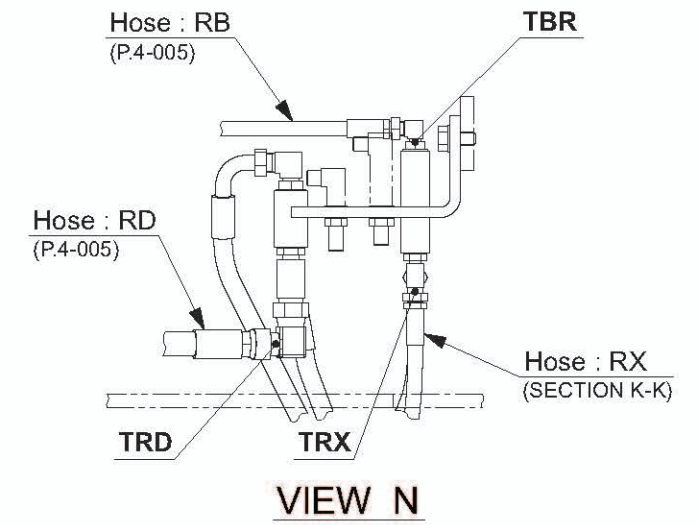
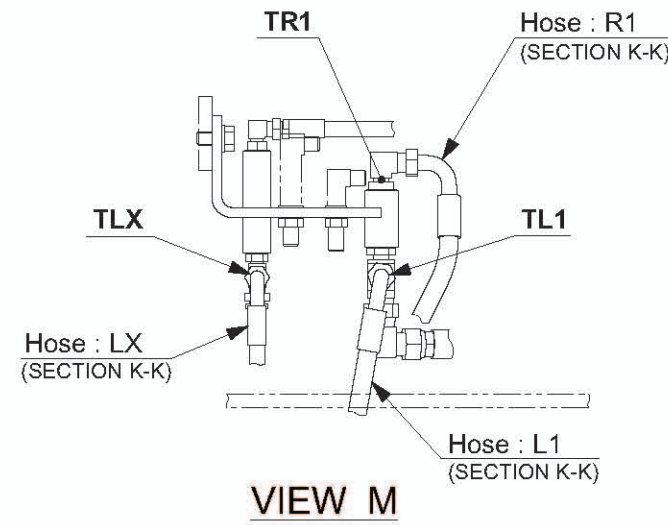
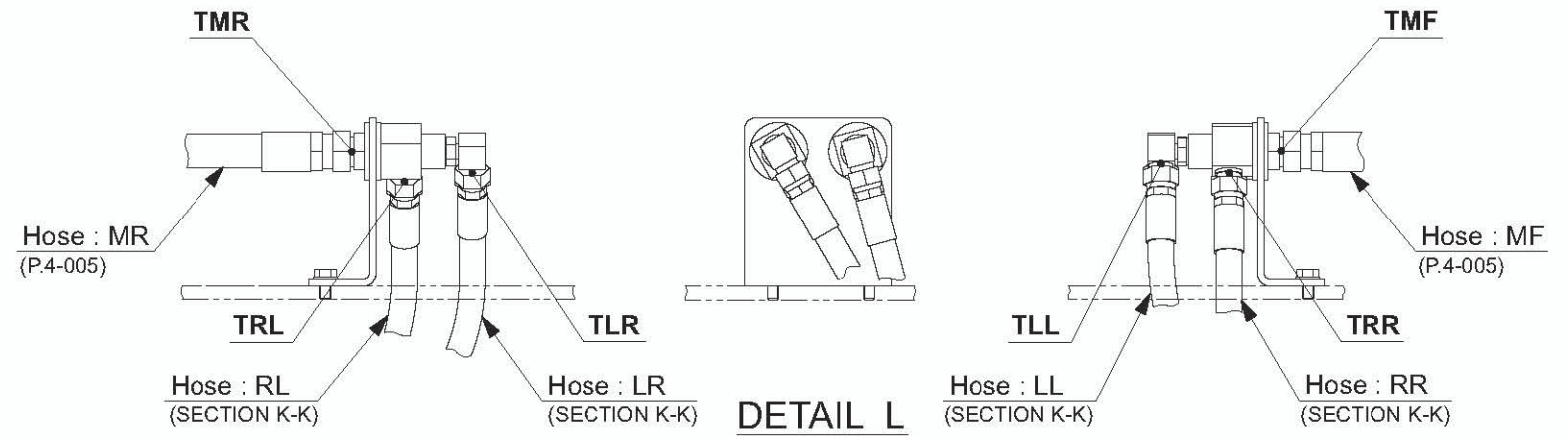
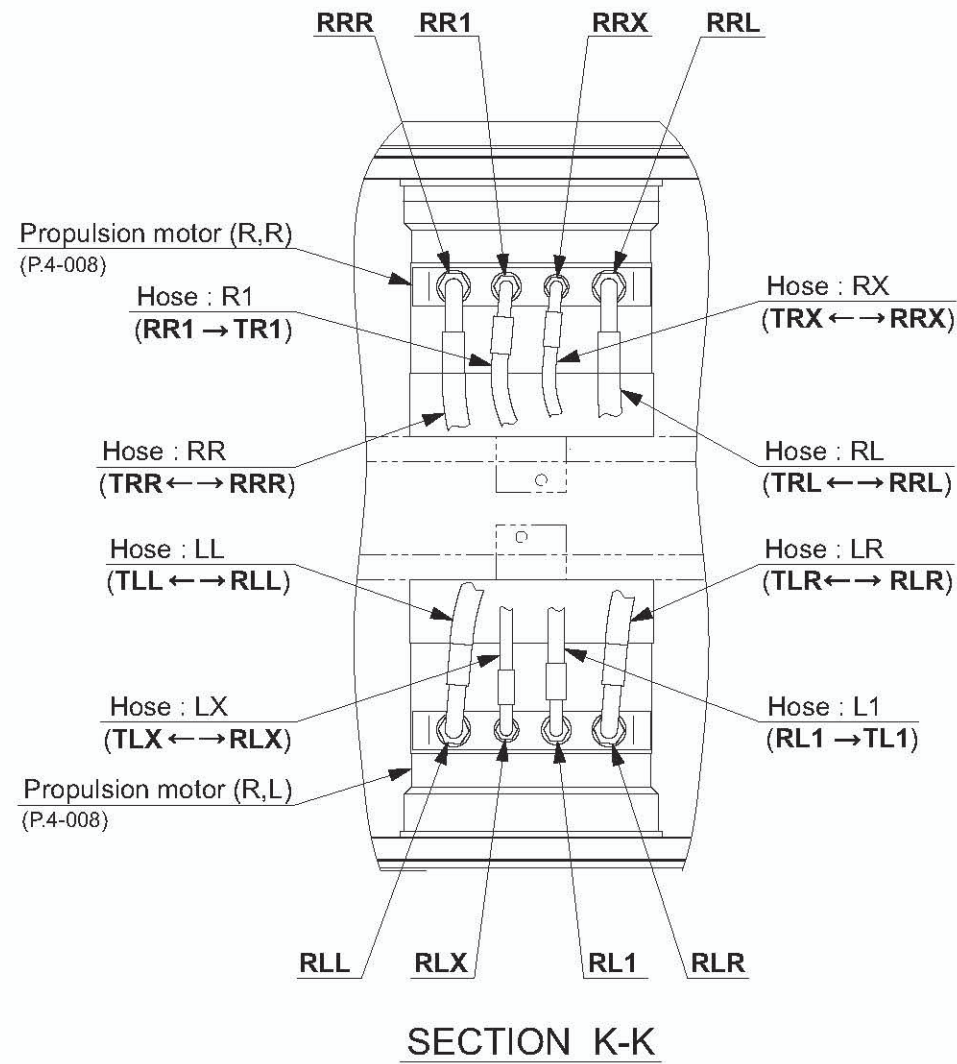

- The letters and numbers in the figure such as “TRX” and “RRX” show each port.
- Arrow “↔; →” symbols show the hose connection and the direction of the flow of the oil.

2-2. Hydraulic Component Specifications

2-2-1. Propulsion hydraulic pump

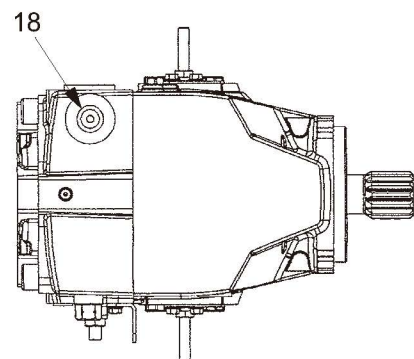
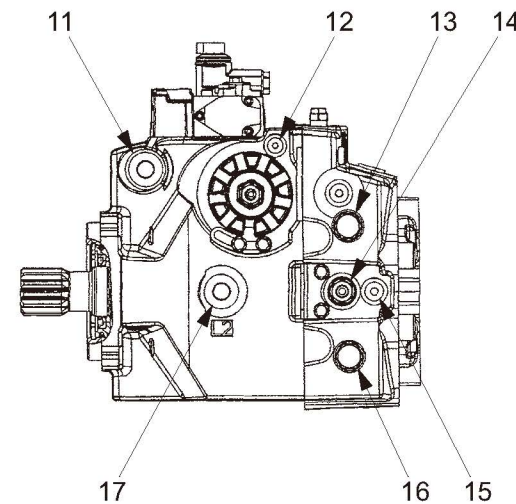
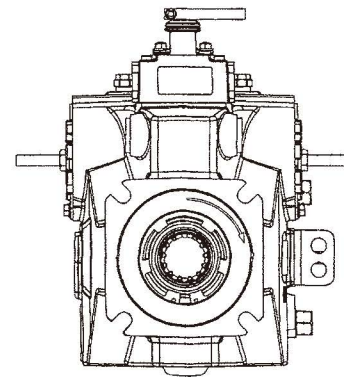
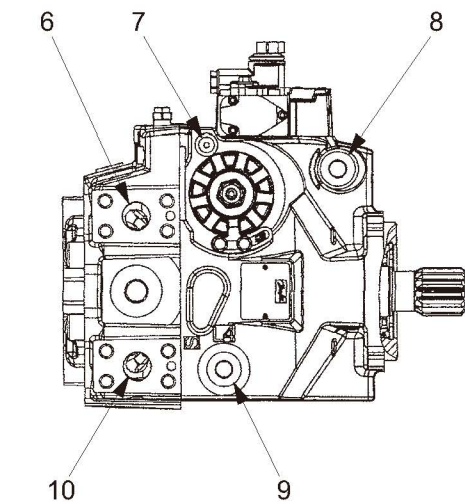
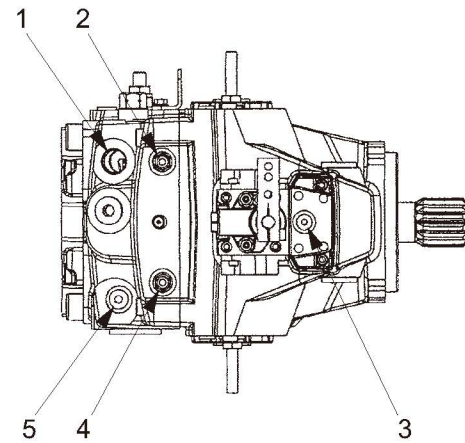

- (1) Charge filtration port [PSF] : 7/ 8-14UNF
- (2) Pressure limiter valve (Reverse)
- (3) Case gauge port : 7/16-20UNF
- (4) Pressure limiter valve (Forward)
- (5) System gauge port (Forward) : 9/16-18UNF
- (6) Port B (Forward) [PPB] : SAE 1"
- (7) Servo gauge port [PMB] : 7/16-20UNF
- (8) Case pressure port : 1 1/16-12UN
- (9) Drain port [PT2] : 1 1/16-12UN
- (10) Port A (Reverse) [PPA] : SAE 1"
- (11) Case pressure port : 1 1/16-12UN
- (12) Servo gauge port [PMA] : 7/16-20UNF
- (13) High pressure relief valve (For Port B)
- (14) Charge pressure relief valve
- (15) Charge gauge port : 9/16-18UNF
- (16) High pressure relief valve (For Port A)
- (17) Drain port : 1 1/16-12UN
- (18) System gauge port (Reverse) : 9/16-18UNF

Specifications

- Displacement : 85 cm³/rev (5.19 cu.in./rev)
- High pressure relief valve pressure setting : 40 MPa (5,800 psi)
- Pressure limiter valve pressure setting : 35 MPa (5,075 psi)
- Charge pressure relief valve pressure setting : 2.4 MPa (348 psi)
- Weight : 62 kg (137 lbs.)

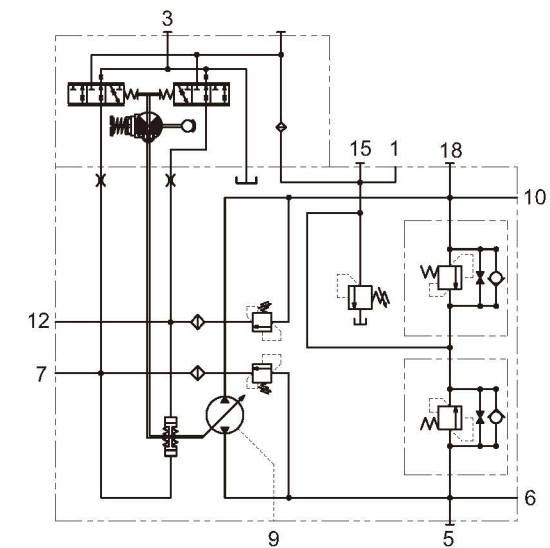

Hydraulic circuit diagram

2-2-2. Propulsion hydraulic motor

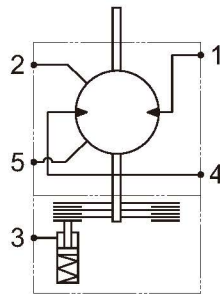
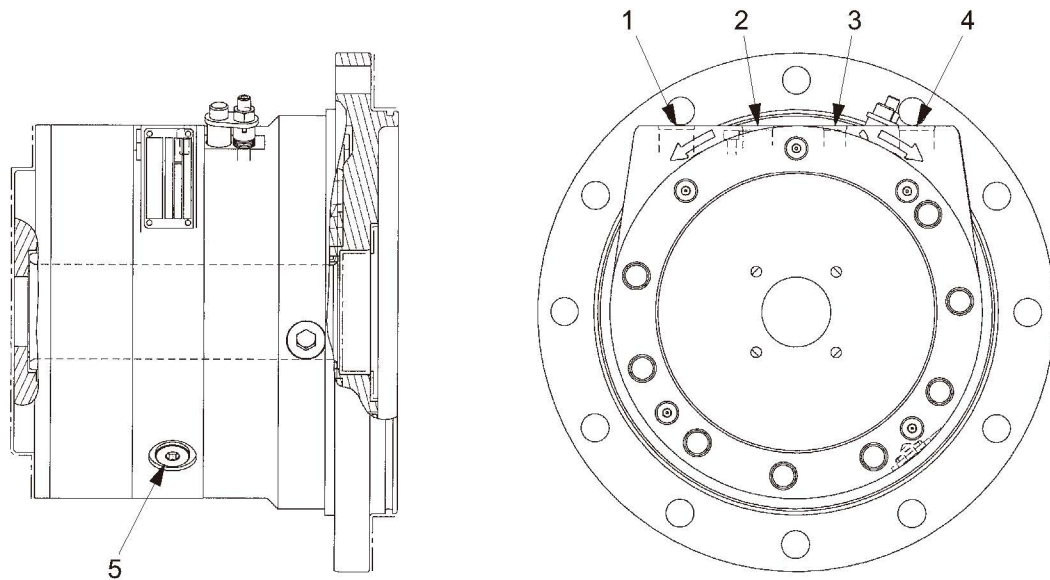

Hydraulic circuit diagram

GW751-04002

- (1) Port R [FMR][RLR][RRR] : 7/ 8-14UNF
- (2) Drain port [FM1] [RL1] [RR1] : 3/ 4-16UNF
- (3) Brake release port [FMX][RLX][RRX] : 9/16-18UNF
- (4) Port L [FML][RLL][RRL] : 7/ 8-14UNF
- (5) Drain port

- [FML], [FMR], [FMX], [FM1] indicates propulsion hydraulic motor (F).
- [RLL], [RLR], [RLX], [RL1] indicates propulsion hydraulic motor (R,L).
- [RRL], [RRR], [RRX], [RR1] indicates propulsion hydraulic motor (R,R).

Specifications

- Displacement : 1,000 cm³/rev (61 cu.in./rev)
- Brake release pressure : 1.4 to 3.0 MPa (203 to 435 psi)
- Allowable motor case pressure : 0.25 MPa or less (36.3 psi)
- Weight : 72 kg (159 lbs.)

2-2-3. Block ASSY (propulsion)

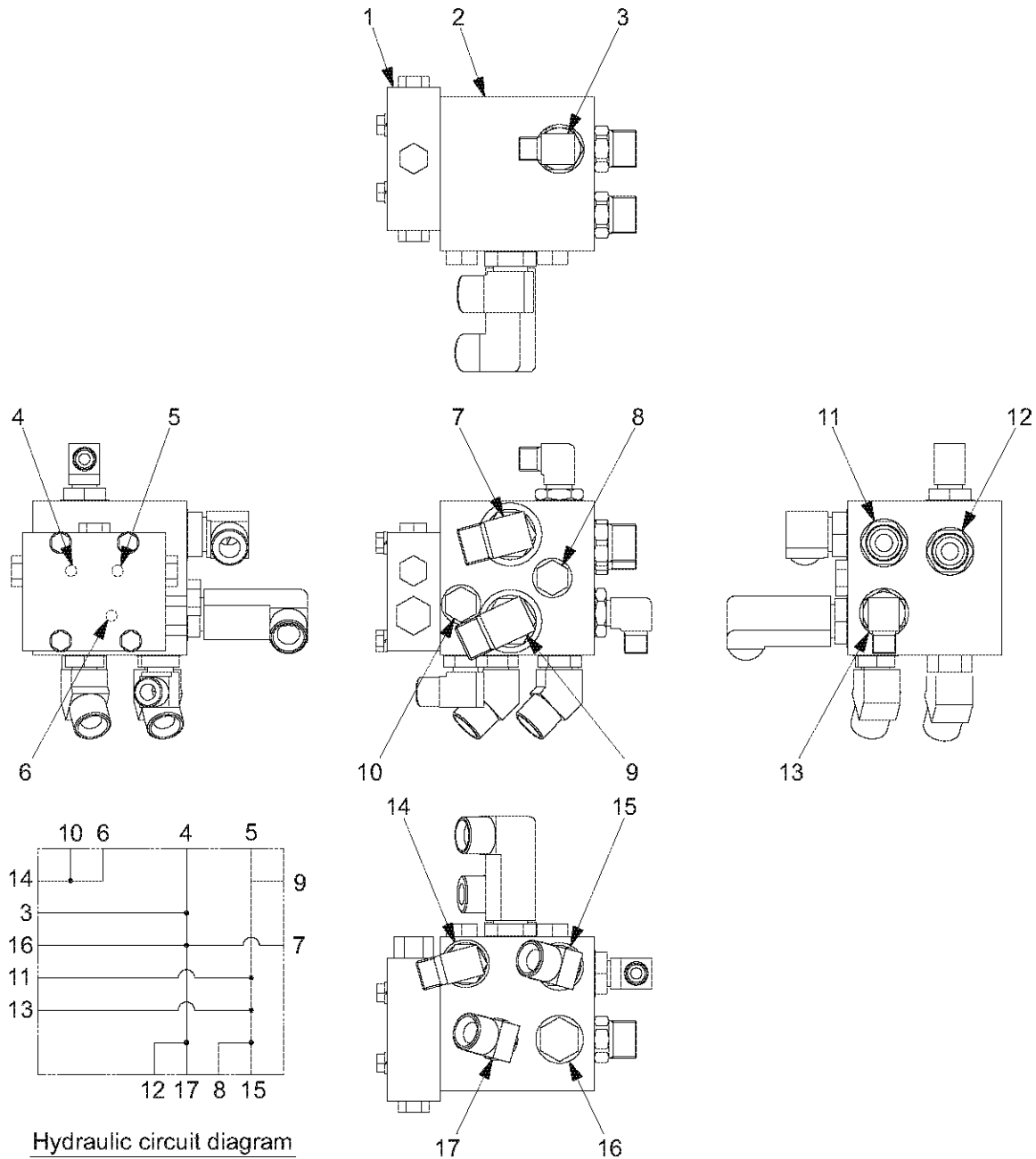

GW754-04002

- | | | | |
|------------------------|---------------------|--------------|---------------------|
| (1) Flushing valve | | (10) Port C3 | : G3/8 |
| (2) Block (propulsion) | | (11) Port A1 | [BRR] : G1/2 |
| (3) Port B1 | [BVA] : G1/2 | (12) Port C2 | [BRL] : G1/2 |
| (4) Port b | : $\phi 8$ | (13) Port A2 | [BVB] : G1/2 |
| (5) Port a | : $\phi 8$ | (14) Port PT | [BPT] : G1/2 |
| (6) Port t | : $\phi 8$ | (15) Port FA | [BFL] : G1/2 |
| (7) Port PB | [BPB] : G3/4 | (16) Port B2 | : G1/2 |
| (8) Port C1 | : G3/8 | (17) Port FB | [BFR] : G1/2 |
| (9) Port PA | [BPA] : G3/4 | | |

1) Flushing valve

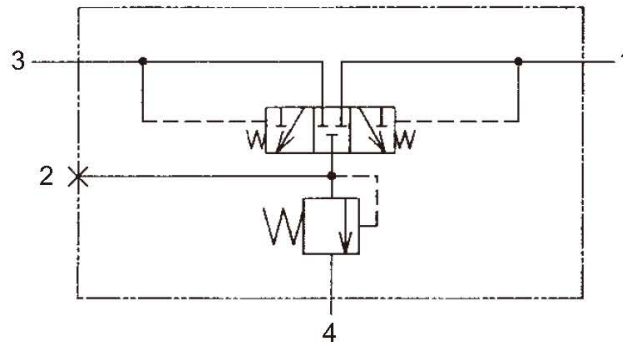
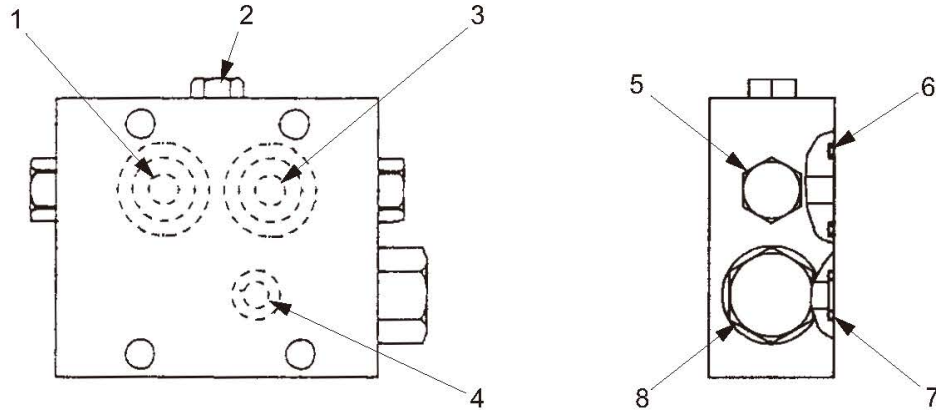

Hydraulic circuit diagram

GW751-04015

- (1) Port B
- (2) Charge pressure gauge port : 7/16-20UNF
- (3) Port A
- (4) Drain port
- (5) Shuttle valve
- (6) O-ring (P22)
- (7) O-ring (P11)
- (8) Charge pressure relief valve

Specifications

- Charge pressure relief valve pressure setting : 2.27 to 2.54 MPa (329 to 368 psi)
- Weight : 2.5 kg (5.5 lbs.)

2-2-4. Block ASSY (front)

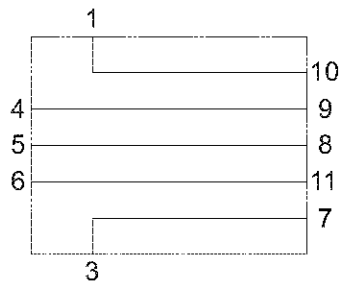
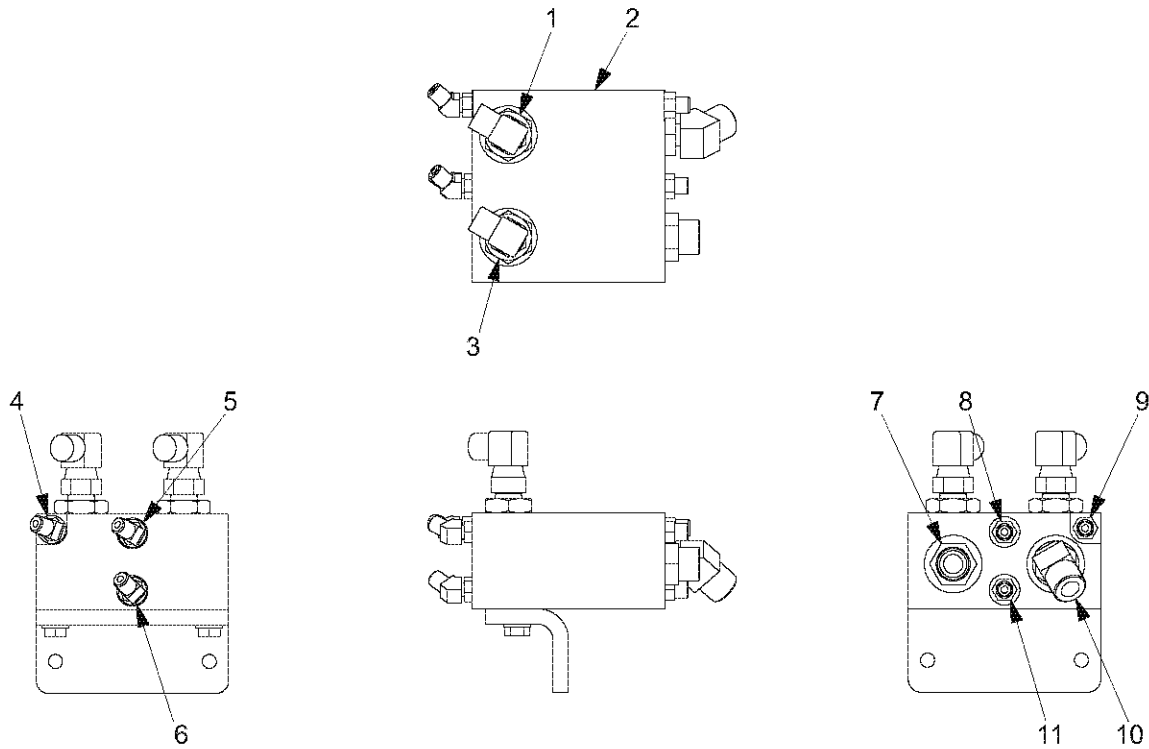

Hydraulic circuit diagram

GW754-04003

- (1) Port A2 **[BA2]** : G3/4
- (2) Block (front)
- (3) Port B2 **[BB2]** : G3/4
- (4) Port E2 **[BE2]** : G1/4
- (5) Port C2 **[BC2]** : G1/4
- (6) Port D2 **[BD2]** : G1/4

- (7) Port B1 **[BB1]** : G3/4
- (8) Port C1 **[BC1]** : G1/4
- (9) Port E1 **[BE1]** : G1/4
- (10) Port A1 **[BA1]** : G3/4
- (11) Port D1 **[BD1]** : G1/4

2-2-5. Servo bypass solenoid valve

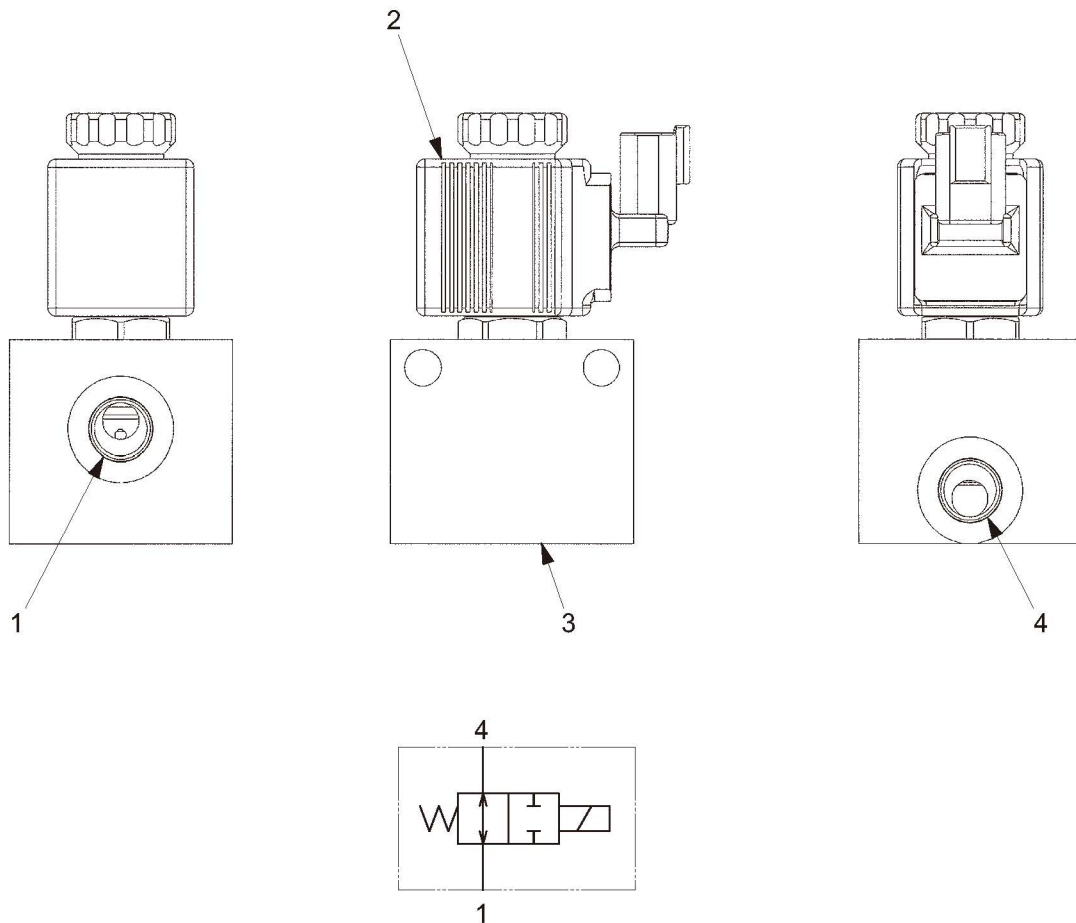

Hydraulic circuit diagram

GW754-04004

- (1) Port B **[VSB]** : 9/16-18UNF
- (2) Solenoid
- (3) Body
- (4) Port A **[VSA]** : 9/16-18UNF

Specifications

- Rated flow : 10 L/min (2.6 gal./min)
- Maximum pressure : 25 MPa (3,625 psi)
- Weight : 0.7 kg (1.5 lbs.)

2-2-6. Parking brake solenoid valve

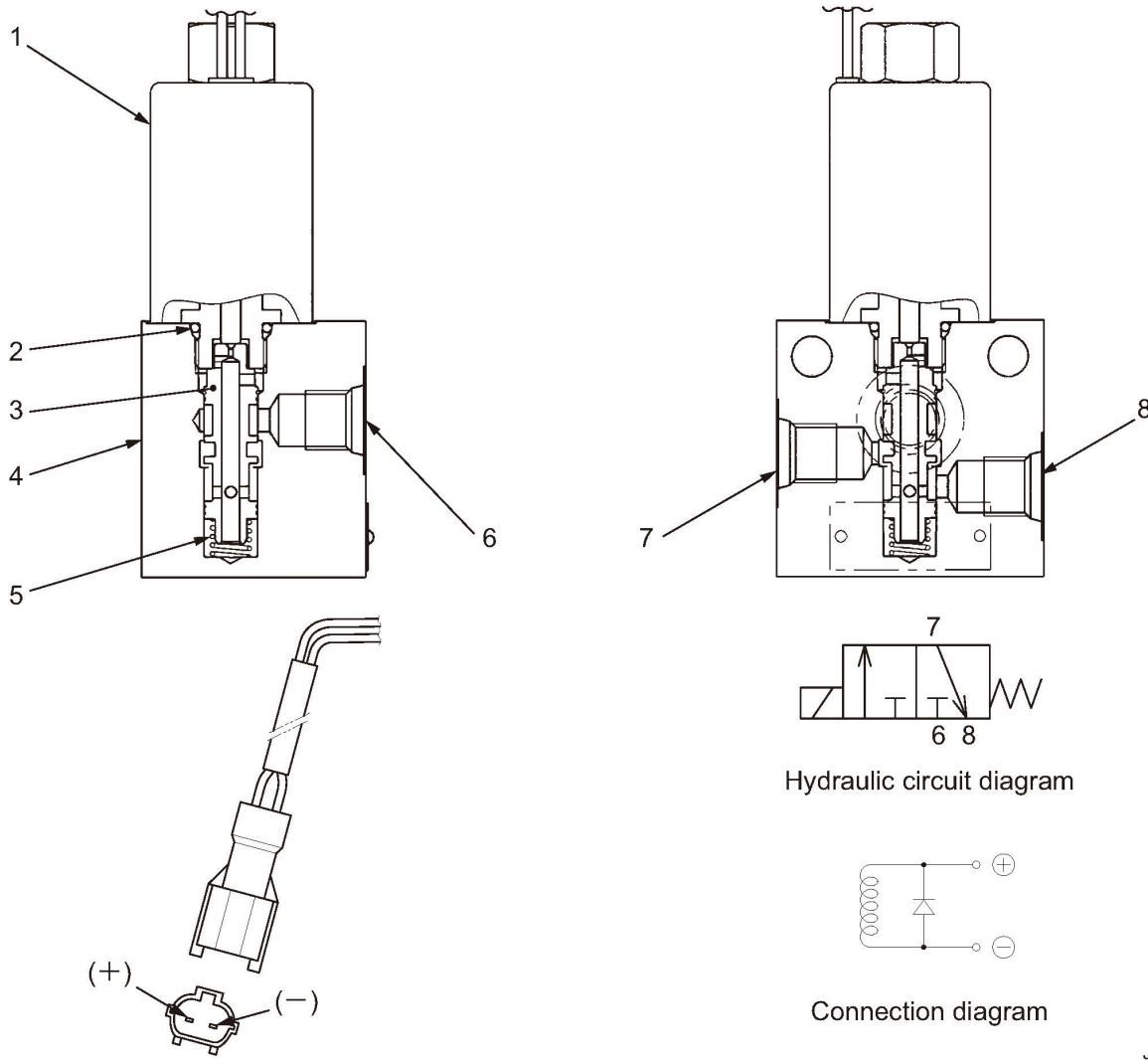

- (1) Solenoid
- (2) O-ring (1B P14)
- (3) Spool (J)
- (4) Body
- (5) Spring
- (6) Port P **[BSP]** : G1/4
- (7) Port A **[BSA]** : G1/4
- (8) Port T **[BST]** : G1/4

Specifications

- Rated flow : 30 L/min (7.9 gal./min)
- Rated pressure : 4.9 MPa (710 psi) (6, 7)
- : 0.5 MPa (72.5 psi) (8)
- Weight : 1.5 kg (3.3 lbs.)

J-40026

2-2-7. Brake valve

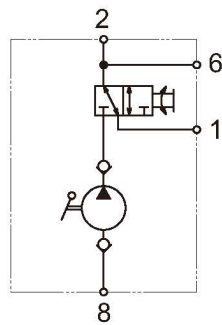
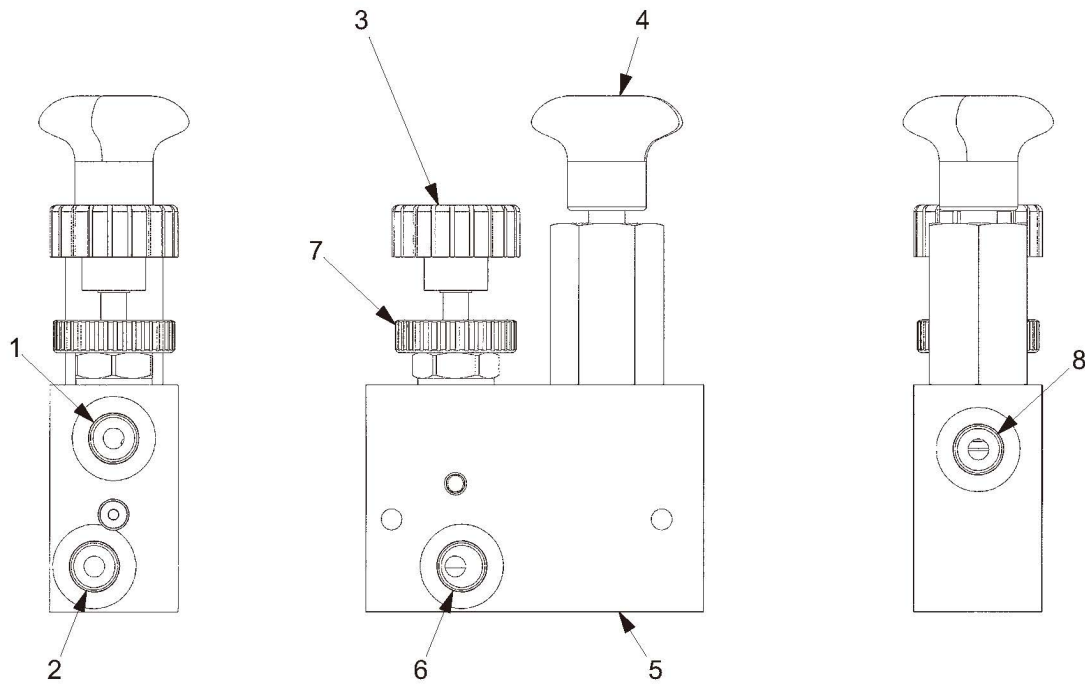

Hydraulic circuit diagram

GW754-04005

- (1) Port A **[VAV]** : 9/16-18UNF
- (2) Port B1 **[VBB]** : 9/16-18UNF
- (3) Selector valve
- (4) Hand pump
- (5) System block
- (6) Port B2 : 9/16-18UNF
- (7) Lock ring
- (8) Port P **[VPT]** : 9/16-18UNF

Specifications

- Maximum flow : 5 L/min (1.3 gal./min)
- Maximum working pressure : 1.8 MPa (261 psi)
- Hand pump displacement : 5.5 mL/stroke (0.0015 gal./stroke)
- Weight : 0.8 kg (1.8 lbs.)

Fig.: Propulsion circuit

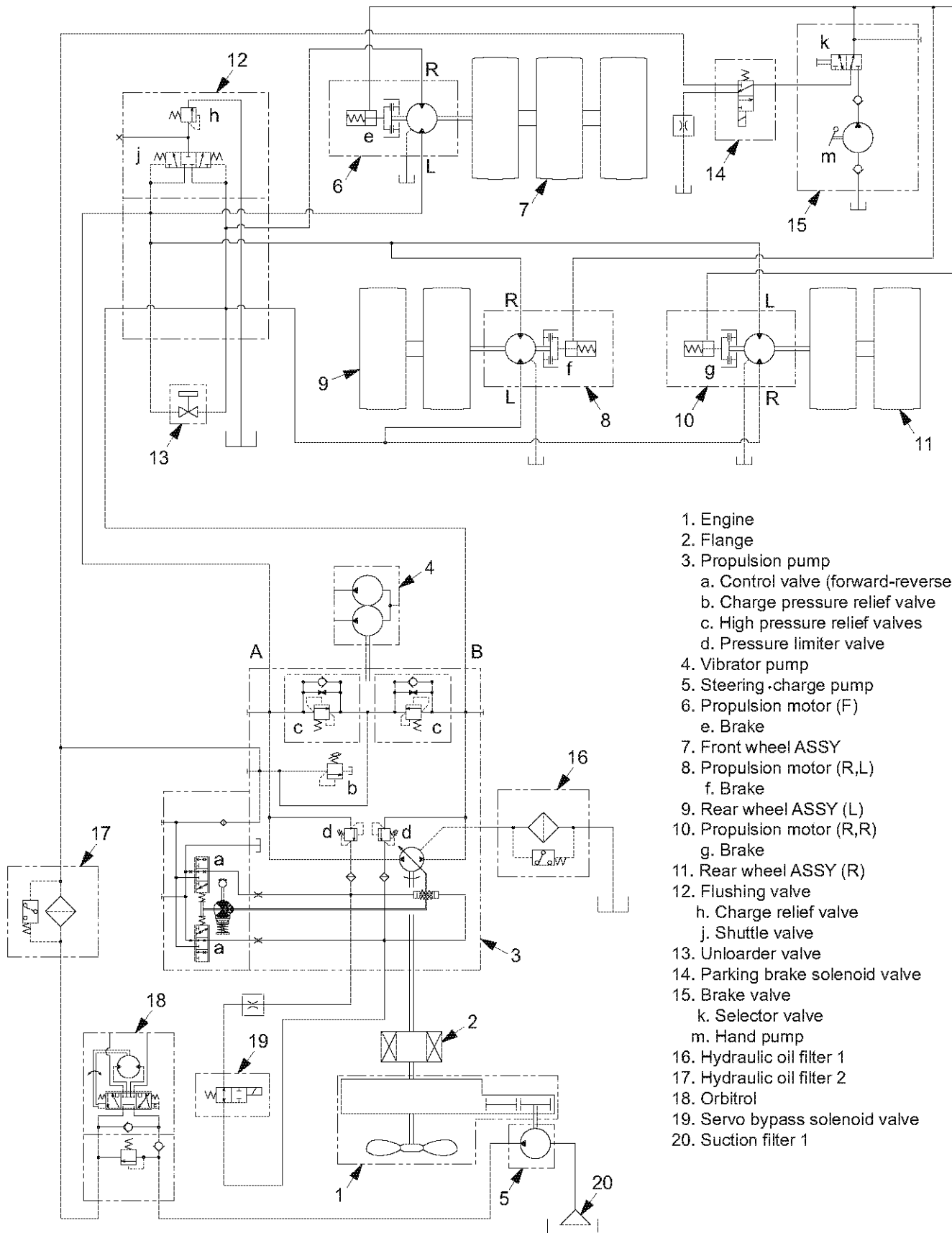

- 1. Engine
- 2. Flange
- 3. Propulsion pump
 - a. Control valve (forward-reverse)
 - b. Charge pressure relief valve
 - c. High pressure relief valves
 - d. Pressure limiter valve
- 4. Vibrator pump
- 5. Steering charge pump
- 6. Propulsion motor (F)
- 7. Front wheel ASSY
- 8. Propulsion motor (R,L)
- 9. Rear wheel ASSY (L)
- 10. Propulsion motor (R,R)
- 11. Rear wheel ASSY (R)
- 12. Flushing valve
 - h. Charge relief valve
 - j. Shuttle valve
- 13. Unloader valve
- 14. Parking brake solenoid valve
- 15. Brake valve
 - k. Selector valve
 - m. Hand pump
- 16. Hydraulic oil filter 1
- 17. Hydraulic oil filter 2
- 18. Orbitrol
- 19. Servo bypass solenoid valve
- 20. Suction filter 1

2-3. Description and Operation of Propulsion System

Description

- Made up of propulsion pump (3), propulsion motor (F) (6), (R,L) (8), (R,R) (10), front wheel ASSY (7), rear wheel ASSY (L) (9), rear wheel ASSY (R) (11), and parking brake solenoid valve (14).

Basic function of propulsion pump and motor

Propulsion pump:

- A piston pump is used. By varying swashplate angle which varies the piston stroke, forward travel, bringing to neutral and backing are achieved.

Propulsion motor:

- A fixed displacement piston motor is used. The displacement per rotation of the motor shaft is not variable.

Operation (It is assumed that the machine travels forward.)

- Assemblies such as pump ASSY and motor ASSY are indicated by numbers such as "1" and "2", while component parts of assemblies are shown by small letters such as "a" and "b".
- The parking brake is supposed to have been released.
- Operation of the F-R lever forward puts pump control valve (a) into function and tilts the pump swashplate in the forward travel direction.
- Propulsion pump (3) discharges oil from its port B. Then the oil flow branches into two lines; one line connecting to forward travel port L of propulsion motor (R,L) (8) and port R of propulsion motor (R,R) (10) and the other line to forward travel port R of propulsion motor (F) (6).
- The oil fed into the ports of the motors drives the motors, flowing out from the opposite side ports (port R in propulsion motor (8) and port L in propulsion motor (6) and (10)) and joins again to flow into port A in propulsion pump (3). At the same time, part of oil is drained to hydraulic oil tank via shuttle valve (j) and the motor casing.

(NOTE)

- **Because the propulsion circuit is a closed circuit, the relationship between the suction port and discharge port is reversed when the travel direction is reversed. (The direction of oil flow reversed.)**

Fig.: Propulsion circuit

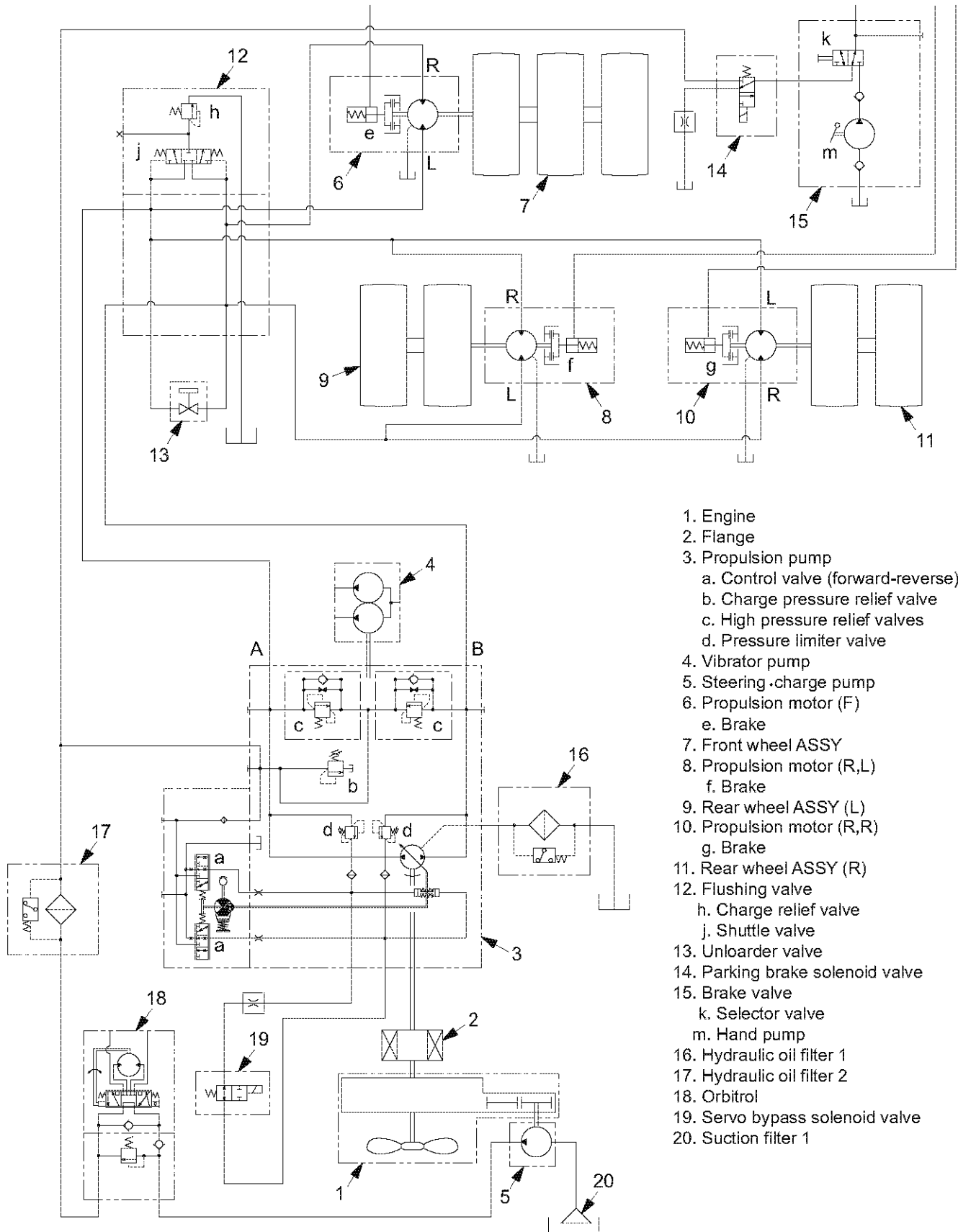

- 1. Engine
- 2. Flange
- 3. Propulsion pump
 - a. Control valve (forward-reverse)
 - b. Charge pressure relief valve
 - c. High pressure relief valves
 - d. Pressure limiter valve
- 4. Vibrator pump
- 5. Steering charge pump
- 6. Propulsor motor (F)
- 7. Front wheel ASSY
 - e. Brake
- 8. Propulsor motor (R,L)
- 9. Rear wheel ASSY (L)
 - f. Brake
- 10. Propulsor motor (R,R)
- 11. Rear wheel ASSY (R)
 - g. Brake
- 12. Flushing valve
 - h. Charge relief valve
 - j. Shuttle valve
- 13. Unloader valve
- 14. Parking brake solenoid valve
- 15. Brake valve
 - k. Selector valve
 - m. Hand pump
- 16. Hydraulic oil filter 1
- 17. Hydraulic oil filter 2
- 18. Orbitrol
- 19. Servo bypass solenoid valve
- 20. Suction filter 1

To release parking brake

- Propulsion motor (6), (8) and (10) contains brake (e), (f) and (g).
- Actuation of the parking brake switch on the instrument panel in the driver's station energizes parking brake solenoid valve (14). The oil under pressure is fed, via parking brake solenoid valve (14), into the brake cylinders.
- This moves the brake pistons against the compression spring load, releasing the brake.

Circuit protection against high pressure

- Pressure limiter valve (d) is fitted in the propulsion pump. If the circuit pressure exceeds the setting of the valve, the valve functions and exerts oil pressure on the pump servo piston to reduce pump delivery.
- Decrease in delivery (travel speed reduction) lowers the circuit pressure.
- In addition to this pressure limiter valve (d), the circuit includes high pressure relief valve (c) which opens to protect the circuit if the circuit pressure exceeds the permissible maximum of the pressure limiter valve (d).

Charge circuit

- The propulsion circuit is of a closed circuit, which needs feeding of oil into it for making up deficiency.
- In the charge circuit, oil from steering • charge pump (5) flows into orbitrol (18), then the whole amount of oil goes to propulsion pump (3) via hydraulic oil filter 2 (17) irrespective of the steering wheel operation.
- Charge pressure relief valve (b) built in propulsion pump (3) maintains the pressure to operate the pump swashplate when the F-R lever is in the neutral position. When travelling, shuttle valve (j) built in flushing valve (12) performs oil renewal, cooling or removal of foreign material as well as keeping the necessary pressure to control the pump swashplate angle.

(NOTE)

- For the "To disengage the brake when towing", refer to page 7-003.

3. VIBRATOR HYDRAULIC SYSTEM

3-1. Vibrator Hydraulic Piping

3-1-1. Vibrator hydraulic piping (pump)

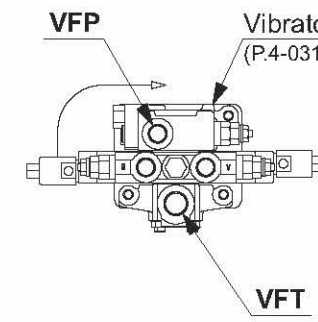
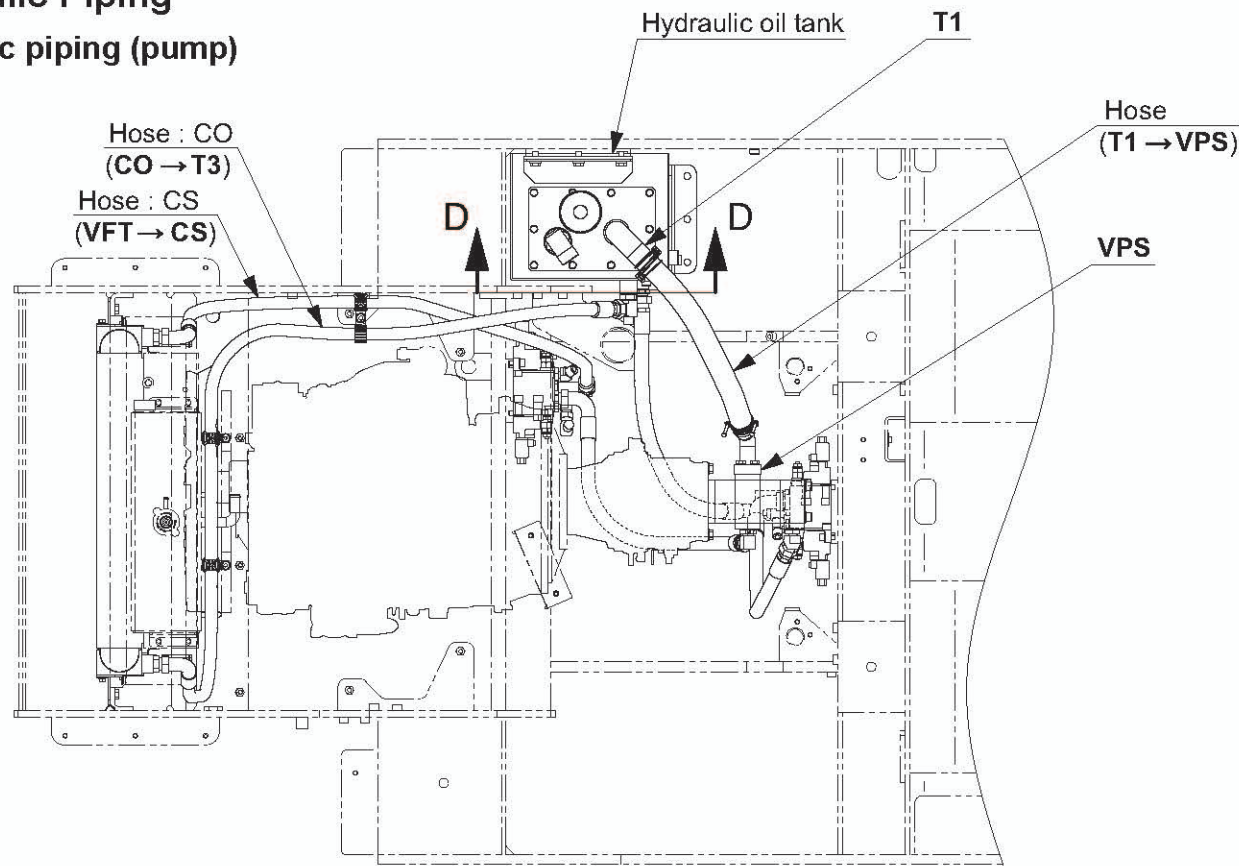

VIEW A

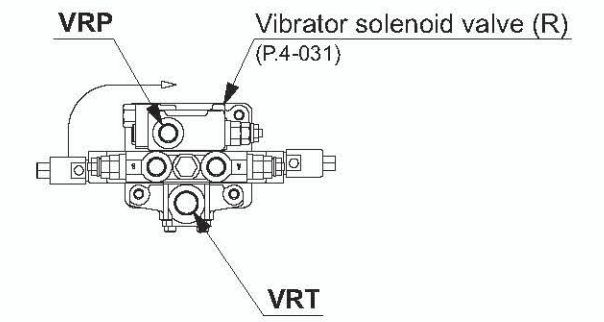

VIEW B

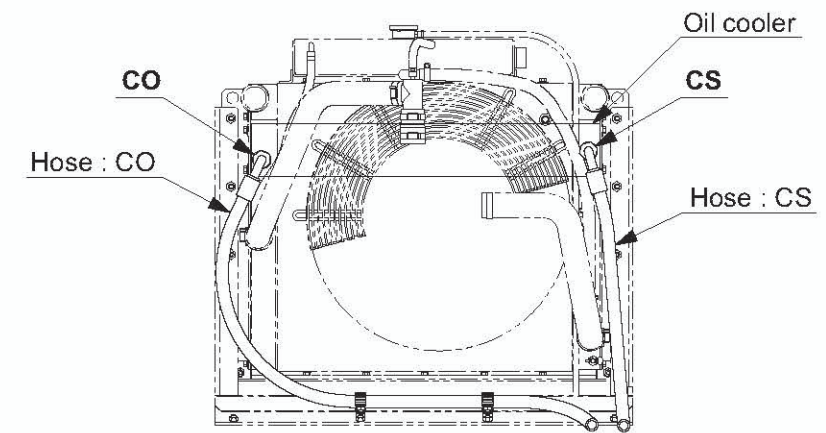

VIEW C

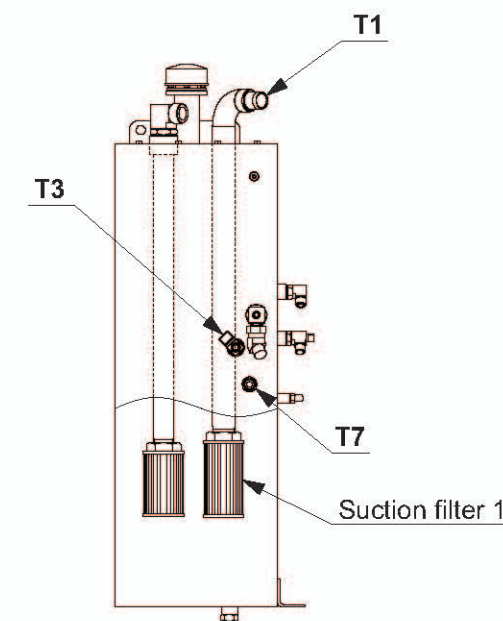
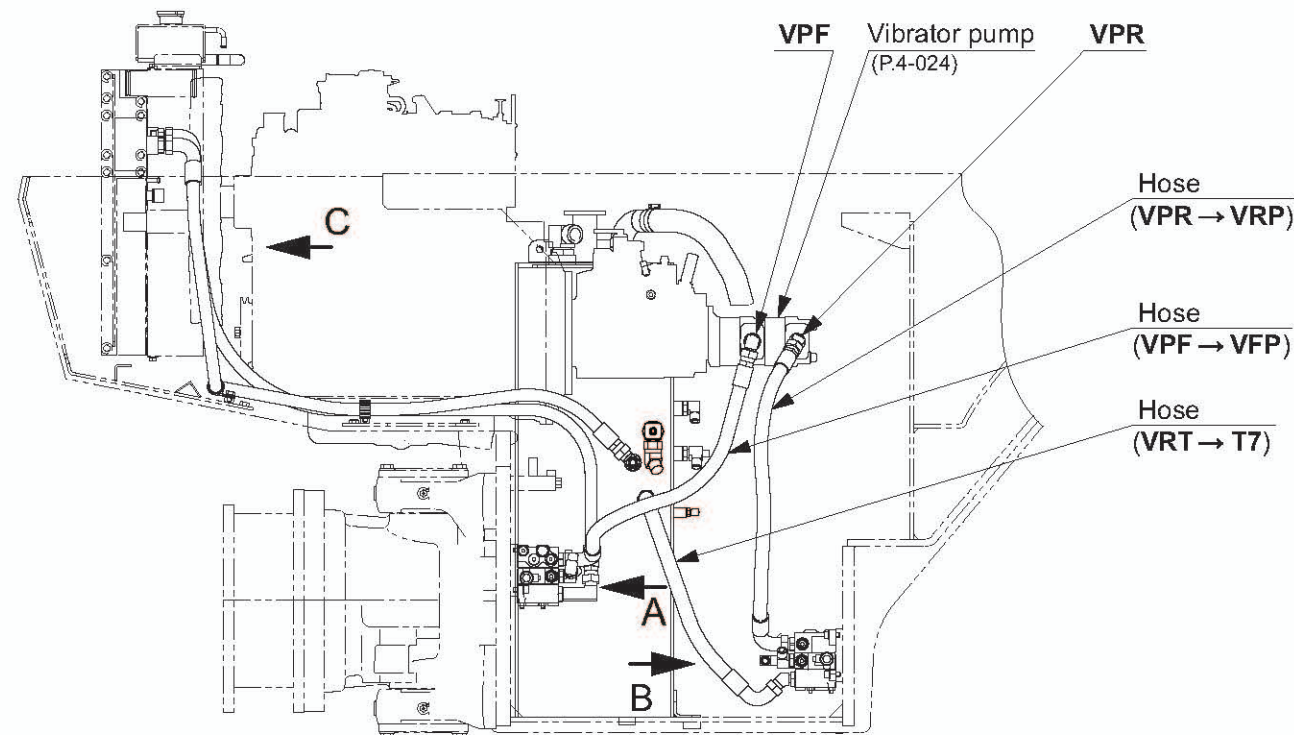

VIEW D-D

- The letters and numbers in the figure such as "CO" and "T3" show each port.
- Arrow "→" symbols show the hose connection and the direction of the flow of the oil.

3-1-2. Vibrator hydraulic piping (motor) (1)

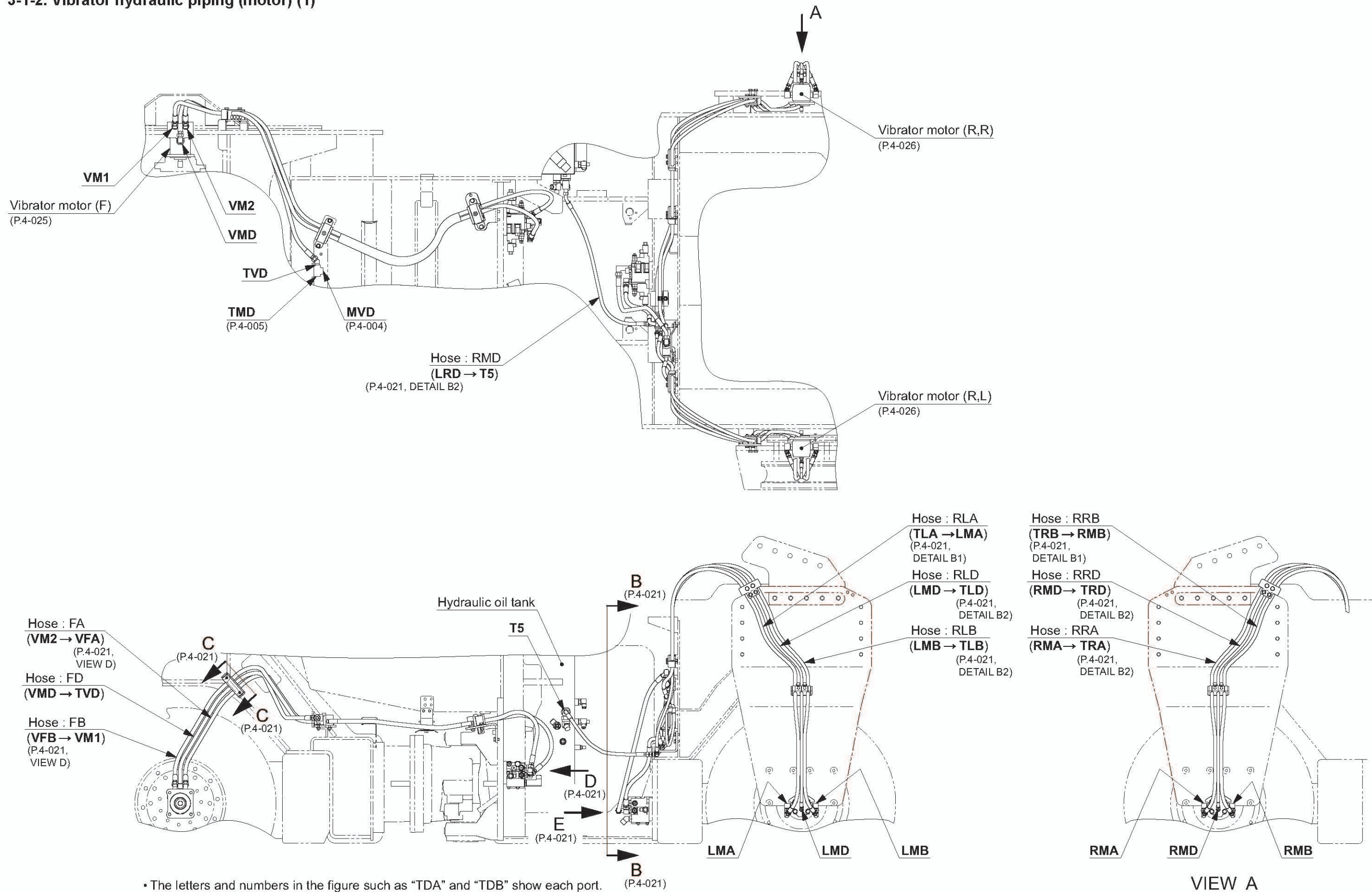

- The letters and numbers in the figure such as “TDA” and “TDB” show each port. (P.4-021)
- Arrow “←→; →” symbols show the hose connection and the direction of the flow of the oil.

3-1-3. Vibrator hydraulic piping (motor) (2)

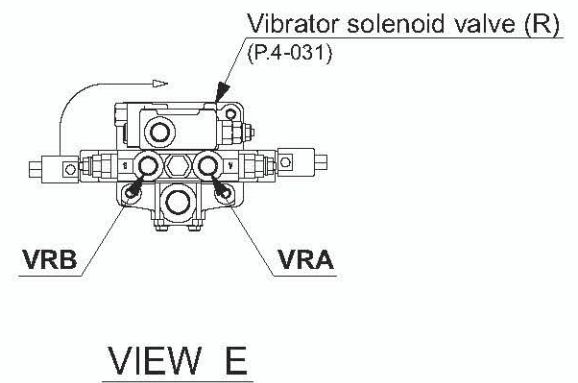
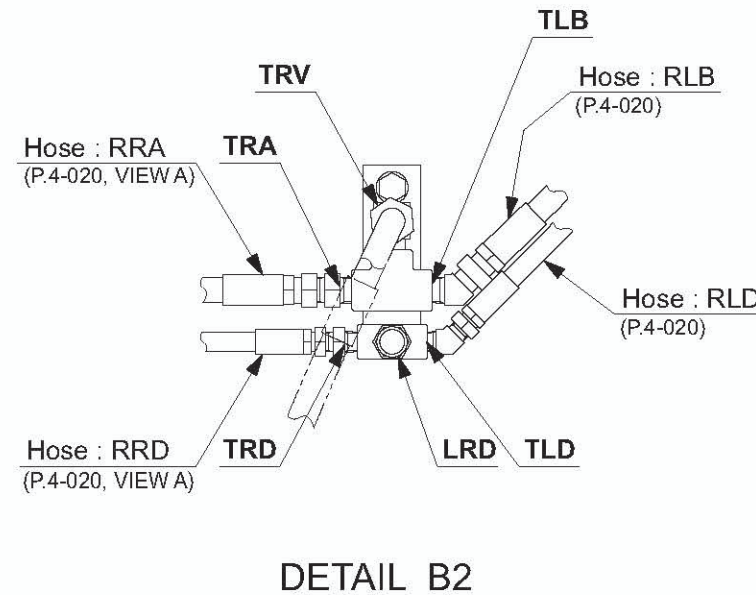
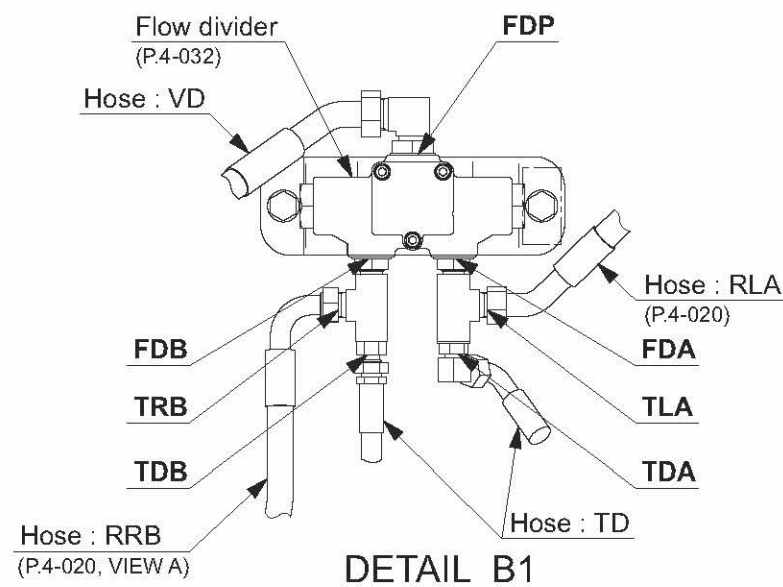
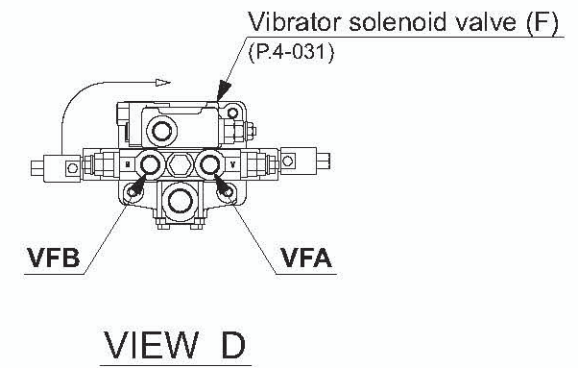
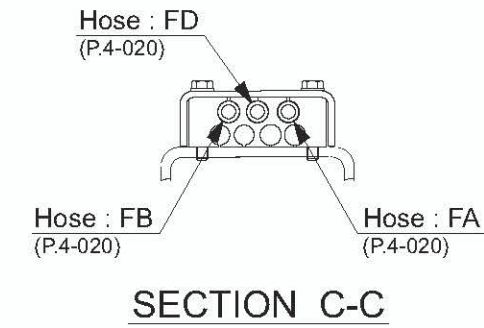
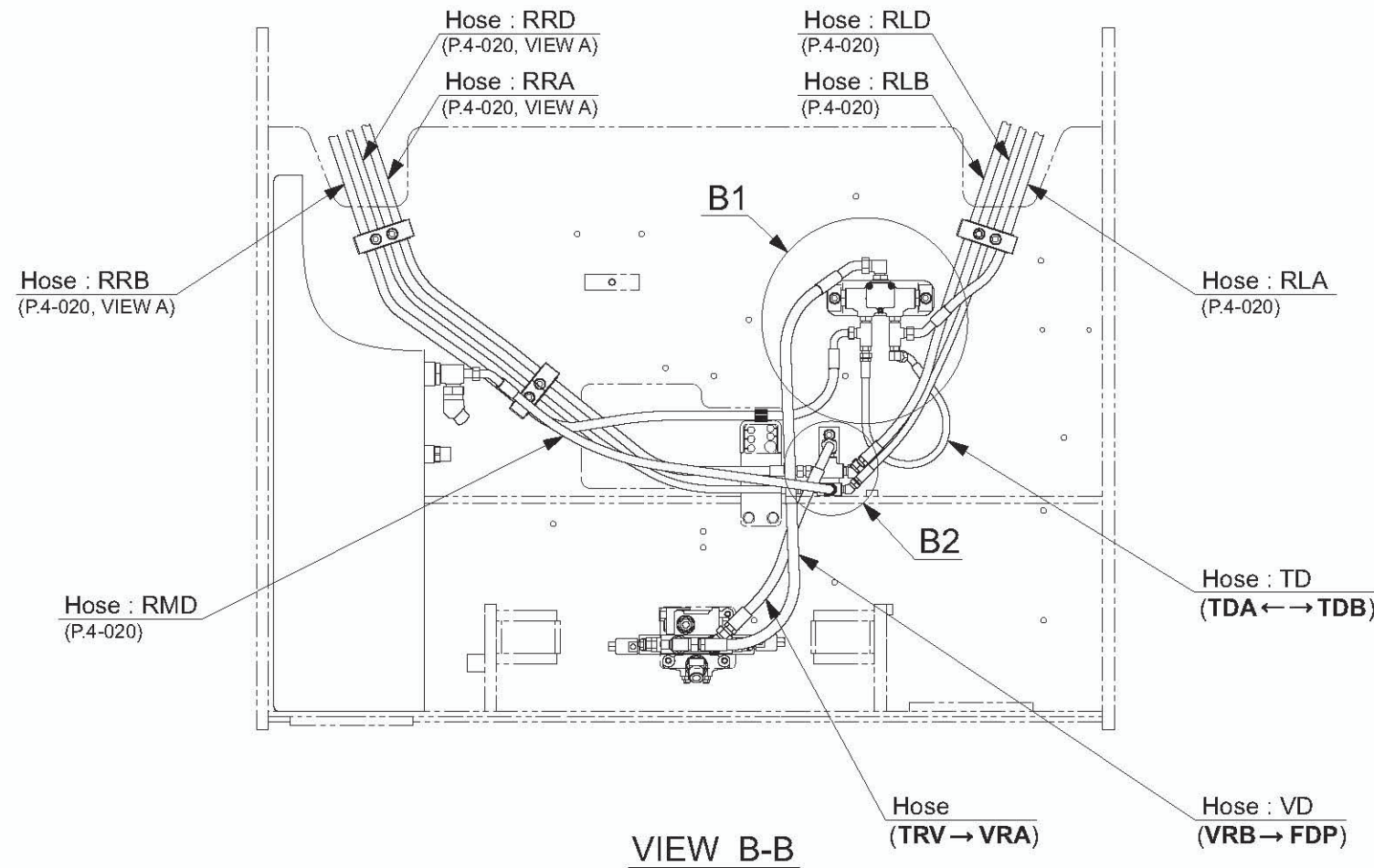

- The letters and numbers in the figure such as “VRB” and “FDP” show each port.
- Arrow “→” symbols show the hose connection and the direction of the flow of the oil.

3-1-4. Amplitude cylinder piping (1)

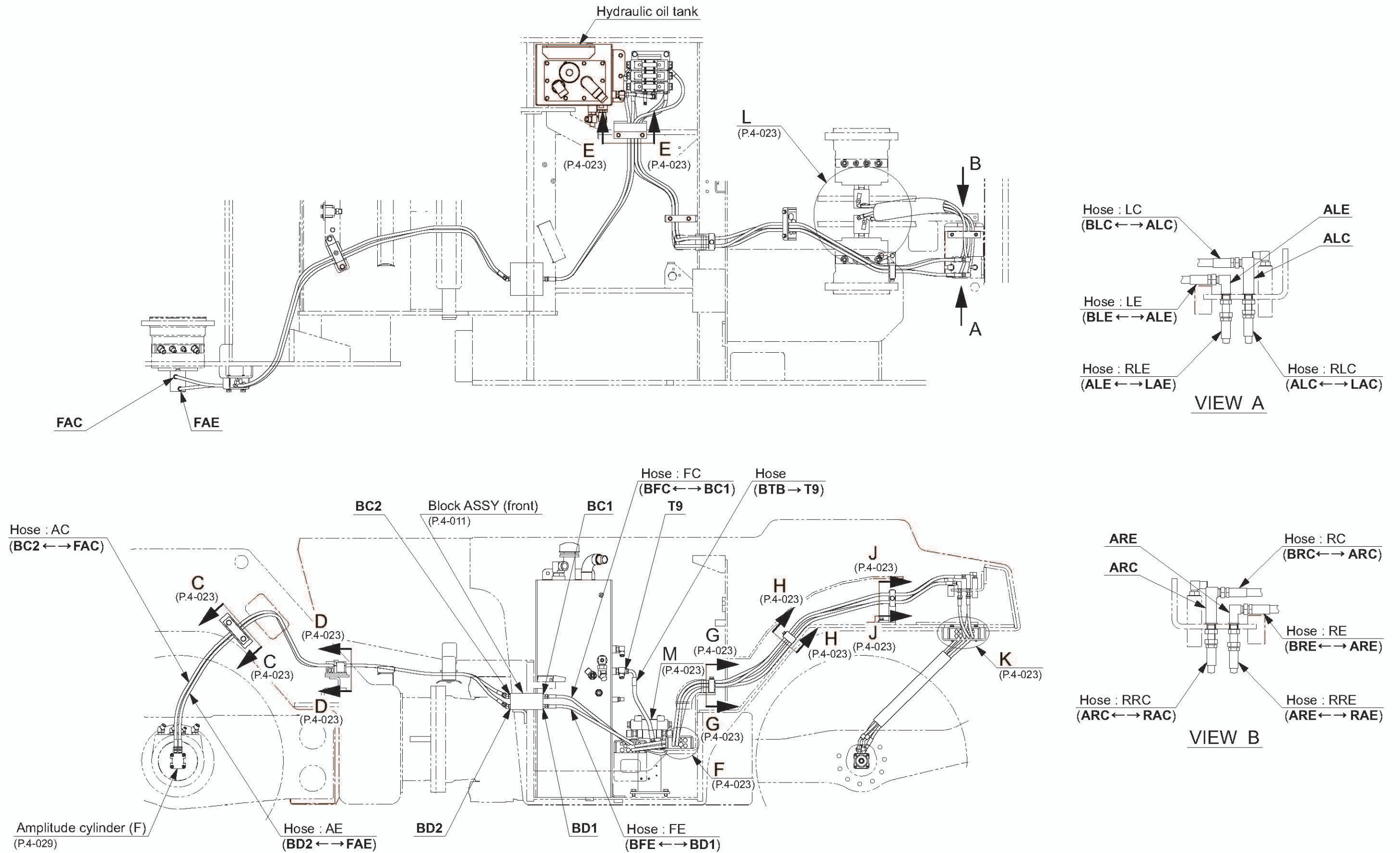

- The letters and numbers in the figure such as “BFE” and “BD1” show each port.
- Arrow “↔ ; →” symbols show the hose connection and the direction of the flow of the oil.

3-1-5. Amplitude cylinder piping (2)

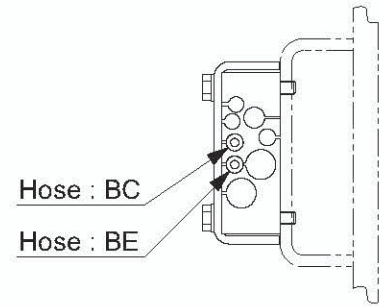

VIEW C-C

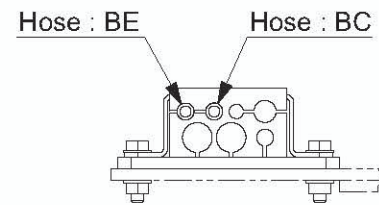

VIEW D-D

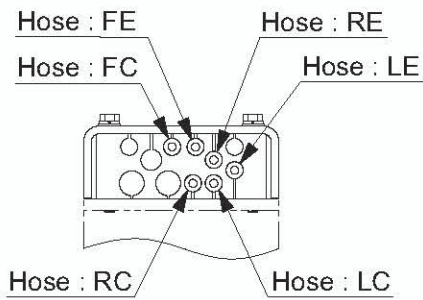

VIEW E-E

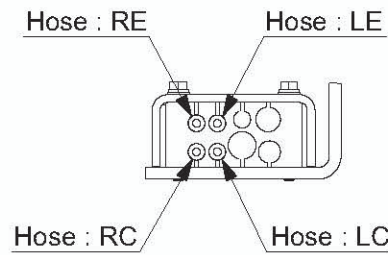

VIEW F-F

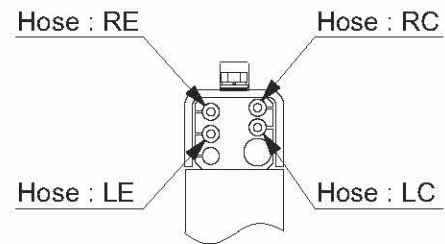

VIEW G-G

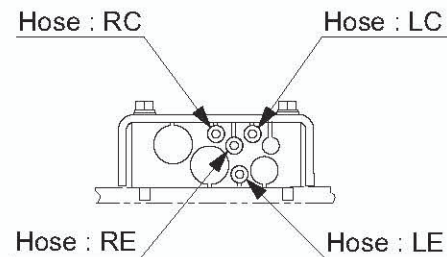

VIEW H-H

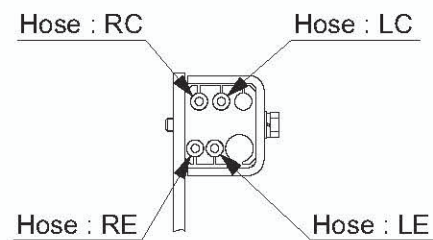

VIEW J-J

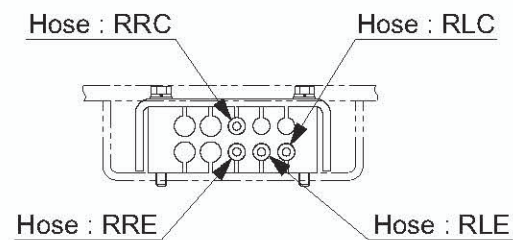

DETAIL K

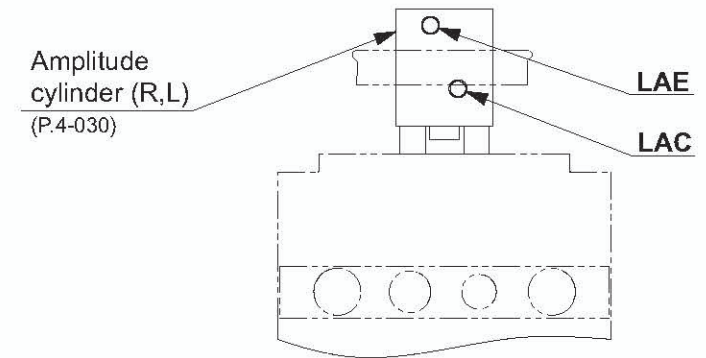
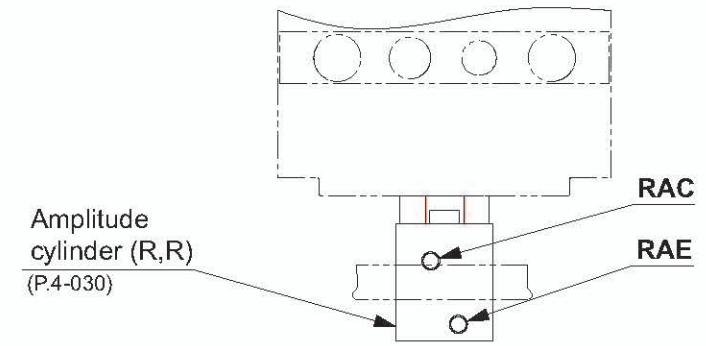

DETAIL L

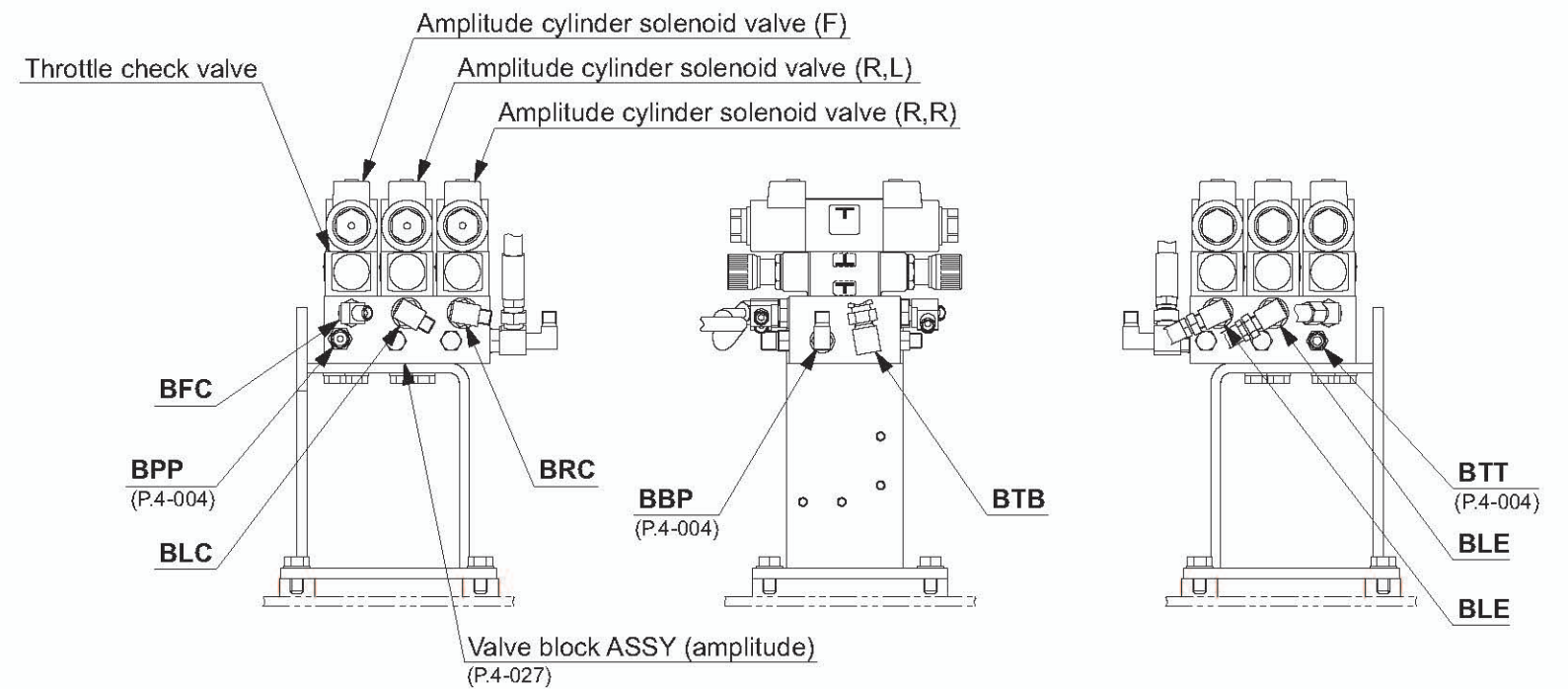

DETAIL M

3-2-2. Vibrator hydraulic motor (F)

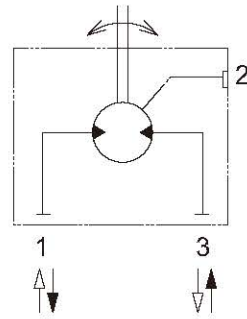
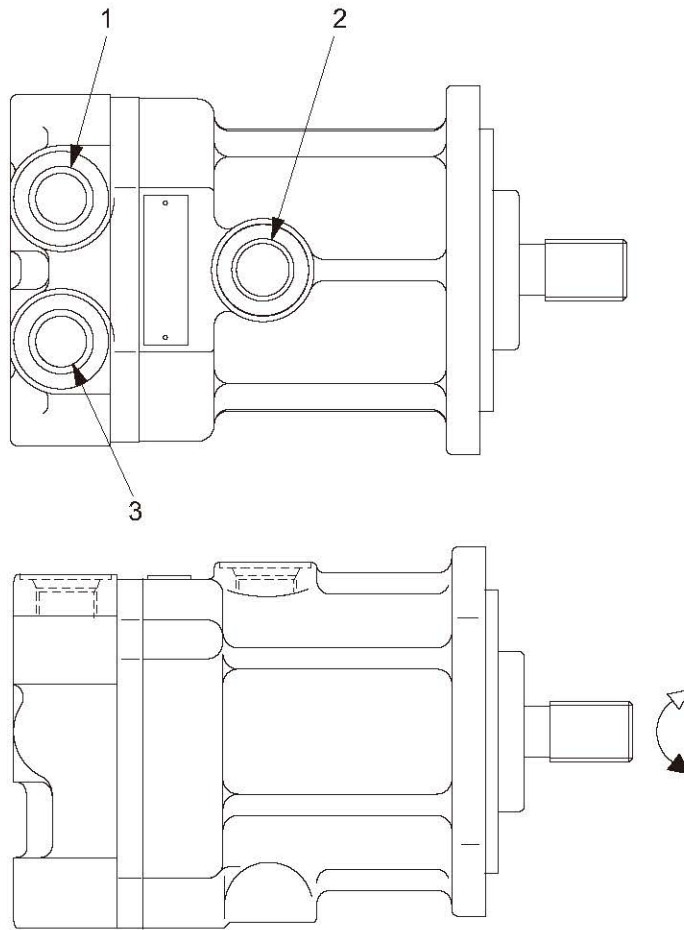

Hydraulic circuit diagram

Flow of oil

- 1→3 Clockwise rotation
- 3→1 Counterclockwise rotation

GW751-04006

- (1) Port P2 **[VM2]** : G1/2
- (2) Port DR **[VMD]** : G1/2
- (3) Port P1 **[VM1]** : G1/2

Specifications

- Displacement : 23.3 cm³/rev (1.42 cu.in./rev)
- Weight : 11 kg (24.3 lbs.)

3-2-3. Vibrator hydraulic motor (R,L), (R,R)

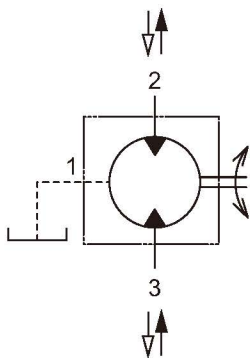
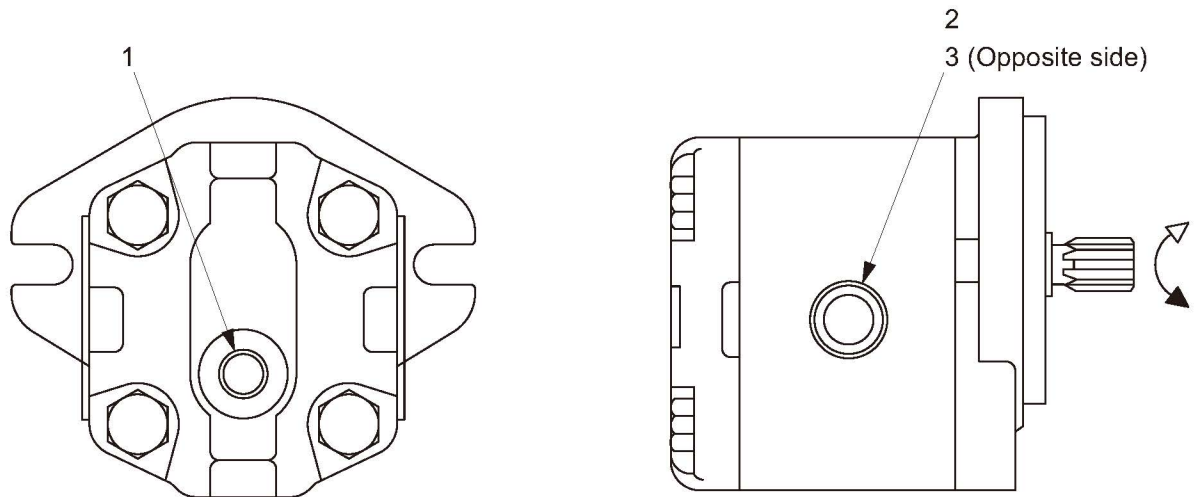

Hydraulic circuit diagram

Flow of oil

- 2→3 Clockwise rotation
- 3→2 Counterclockwise rotation

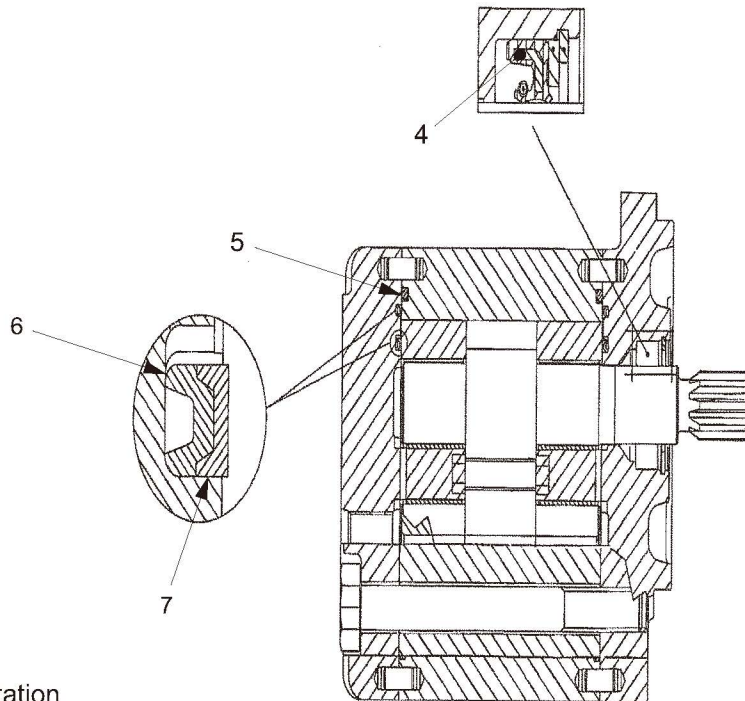

GW751-04007

- | | | | |
|----------------|------------|--------------|-------------------|
| (1) Drain port | [LMD][RMD] | : 9/16-18UNF | (5) O-ring |
| (2) Port B | [LMB][RMB] | : 7/ 8-14UNF | (6) Pressure seal |
| (3) Port A | [LMA][RMA] | : 7/ 8-14UNF | (7) Backing ring |
| (4) Shaft seal | | | |

- [LMA], [LMB], [LMD] indicates vibrator hydraulic motor (R,L).
- [RMA], [RMB], [RMD] indicates vibrator hydraulic motor (R,R).

Specifications

- Displacement : 10.8 cm³/rev (0.66 cu.in./rev)
- Weight : 11 kg (24.3 lbs.)

3-2-4. Valve block ASSY (amplitude)

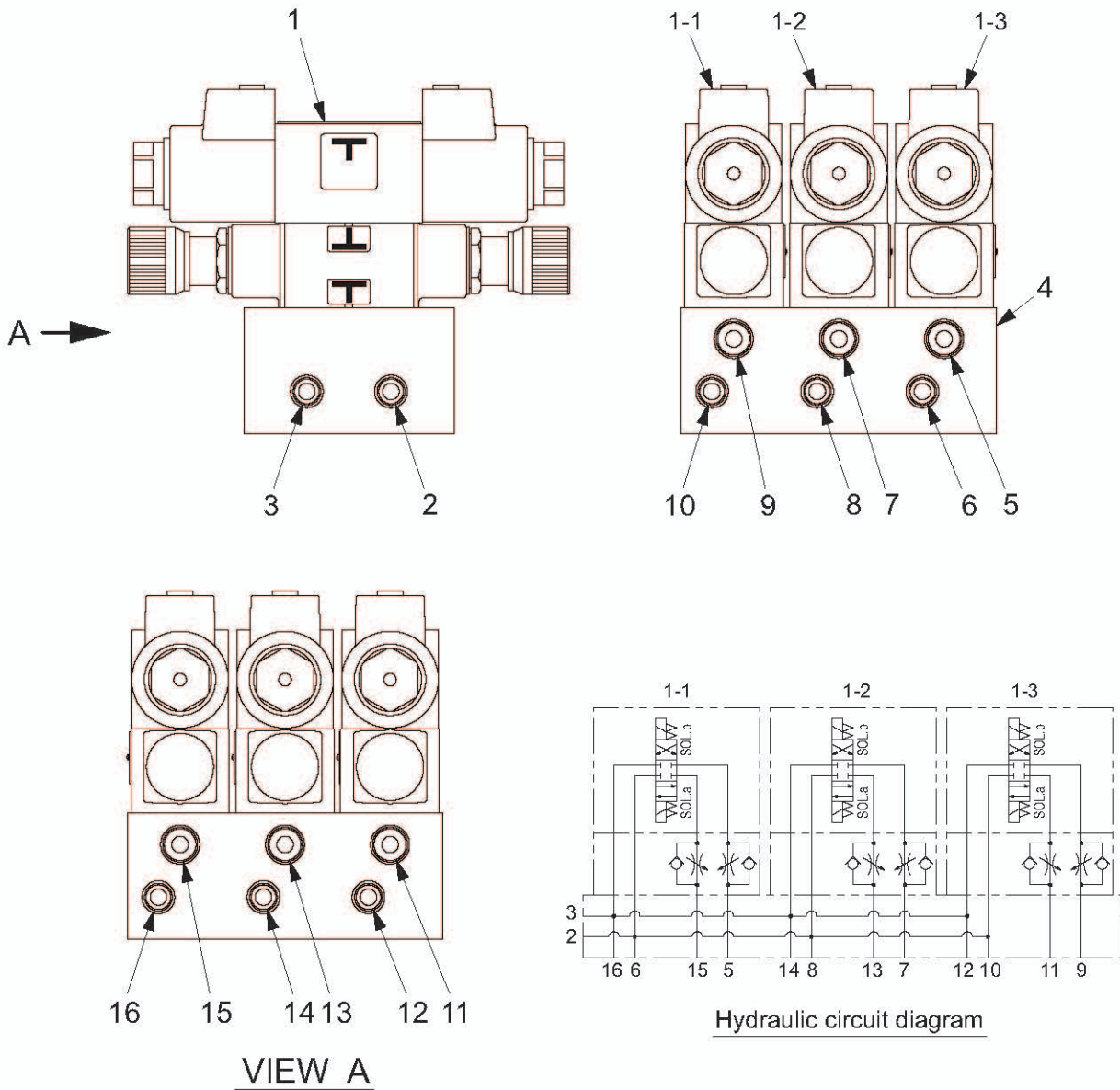

GW754-04007

- | | | | |
|-----------------------|---------------------|--------------|---------------------|
| (1) Valve ASSY | | (9) Port A3 | [BRE] : G3/8 |
| (2) Port T | [BTB] : G1/4 | (10) Port T3 | : G1/4 |
| (3) Port P | [BBP] : G1/4 | (11) Port B3 | [BRC] : G3/8 |
| (4) Block (amplitude) | | (12) Port P3 | : G1/4 |
| (5) Port A1 | [BFE] : G3/8 | (13) Port B2 | [BLC] : G3/8 |
| (6) Port T1 | [BTT] : G1/4 | (14) Port P2 | : G1/4 |
| (7) Port A2 | [BLE] : G3/8 | (15) Port B1 | [BFC] : G3/8 |
| (8) Port T2 | : G1/4 | (16) Port P1 | [BPP] : G1/4 |

1) Valve ASSY

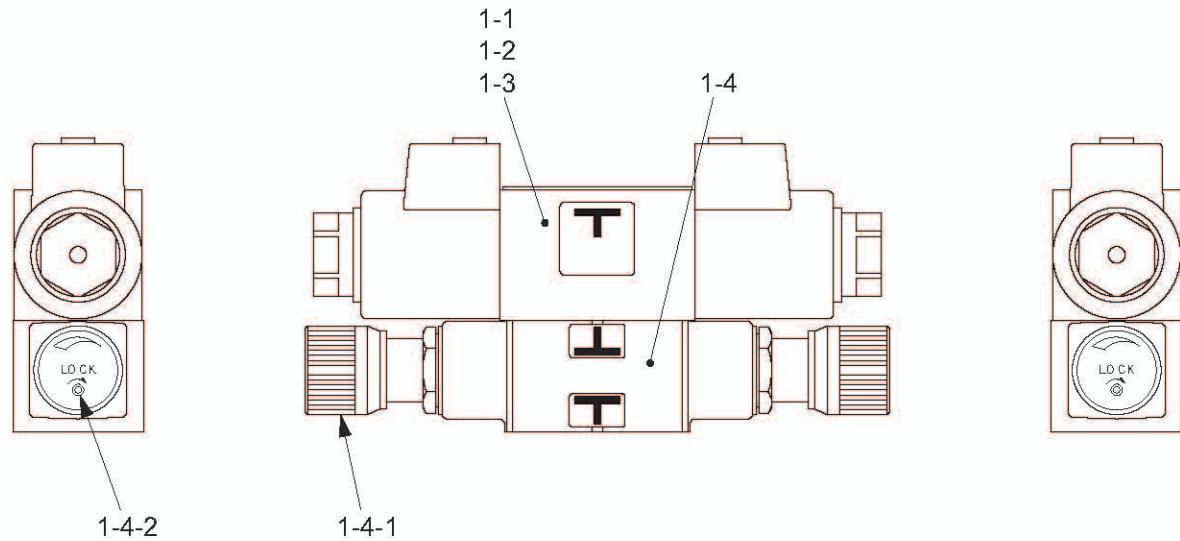

GW754-04008

- (1-1) Amplitude cylinder solenoid valve (F)
 (1-2) Amplitude cylinder solenoid valve (R,L)
 (1-3) Amplitude cylinder solenoid valve (R,R)

Specifications

- Maximum flow : 100 L/min (26.4 gal./min)
- Maximum working pressure : 35 MPa (5,075 psi)

- (1-4) Throttle check valve
 (1-4-1) Flow-regulating dial
 (1-4-2) Dial fixing screw

Specifications

- Maximum flow : 35 L/min (9.2 gal./min)
- Maximum working pressure : 31.5 MPa (4,568 psi)

Adjusting the flow rate

- Loosen the dial fixing screw. Turn the flow-regulating dial clockwise to decrease the flow.
 Make sure to tighten the dial fixing screw when the adjustment is complete.

3-2-5. Amplitude cylinder (F)

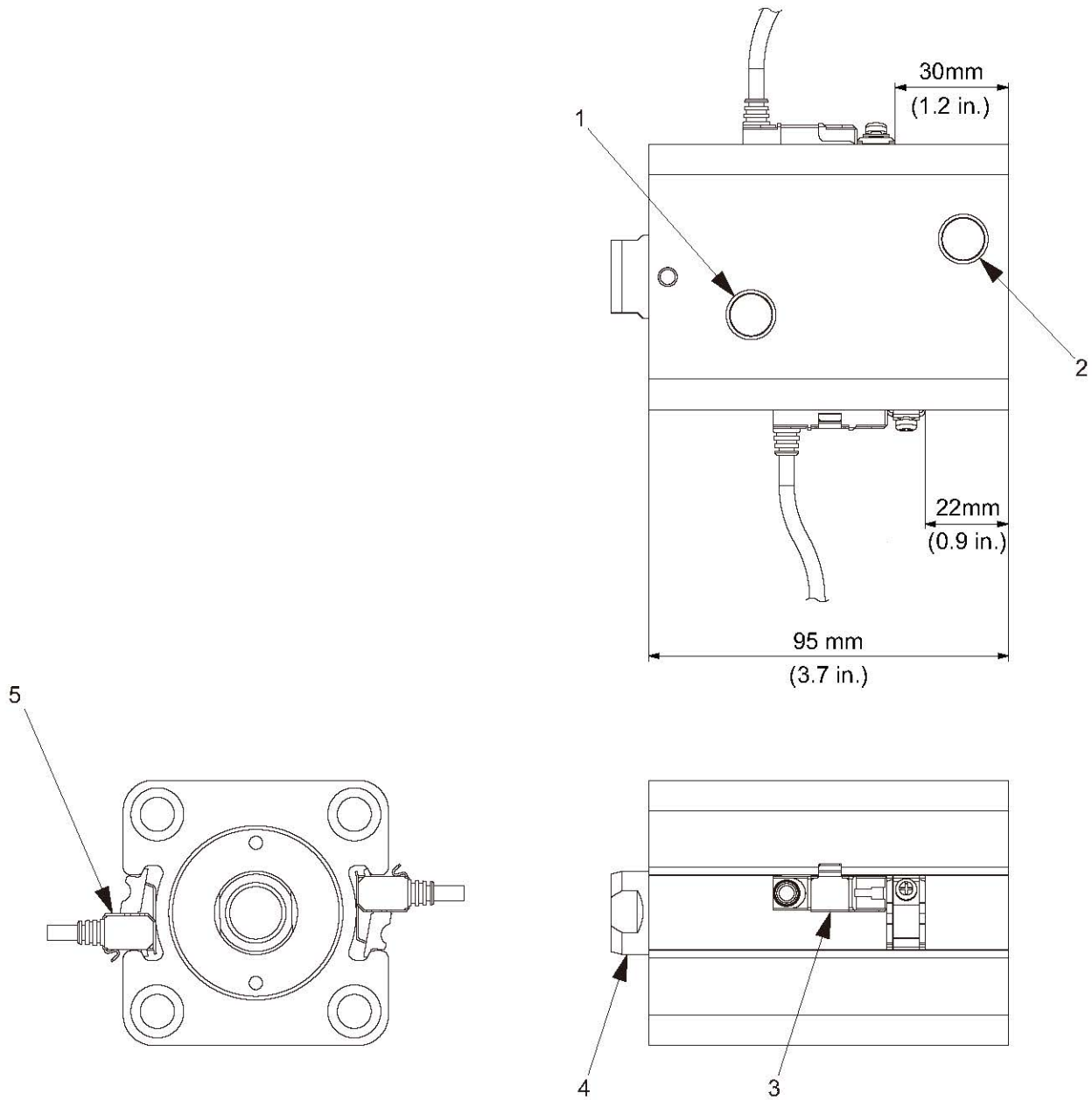

GW754-04009

- (1) Port (Contract) **[FAC]** : Rc1/4
- (2) Port (Extend) **[FAE]** : Rc1/4
- (3) Amplitude cylinder switch (white tape)
- (4) Cylinder rod
- (5) Amplitude cylinder switch

Specifications

- Maximum working pressure : 20 MPa (2,900 psi)
- Bore × Stroke : 40 mm × 40 mm (1.6 in. × 1.6 in.)
- Weight : 1.6 kg (3.5 lbs.)

3-2-6. Amplitude cylinder (R,L), (R,R)

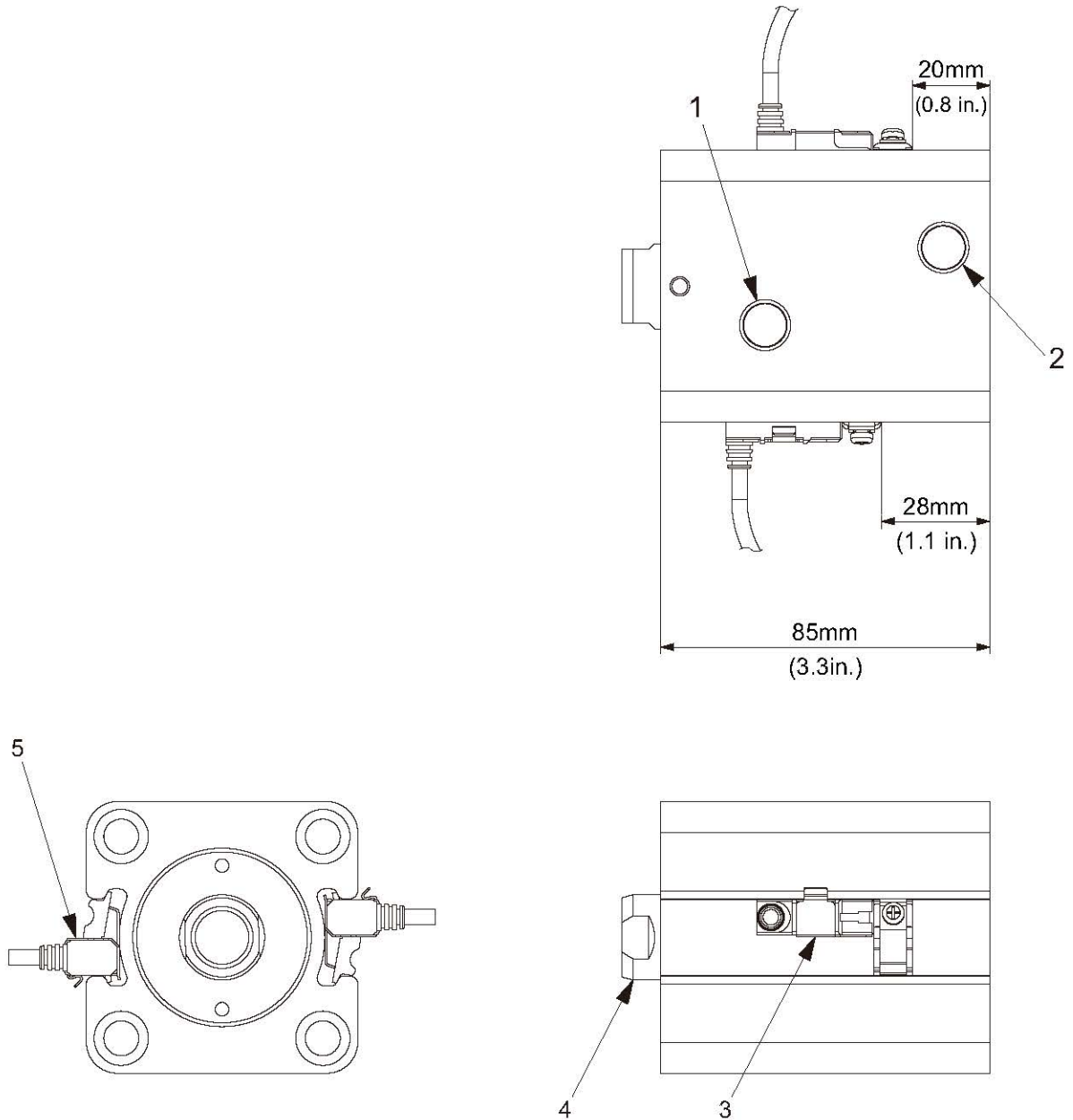

GW754-04010

- (1) Port (Contract) **[LAC][RAC]** : Rc1/4
- (2) Port (Extend) **[LAE][RAE]** : Rc1/4
- (3) Amplitude cylinder switch (white tape)
- (4) Cylinder rod
- (5) Amplitude cylinder switch

- **[LAC]**, **[LAE]** indicates amplitude cylinder (R,L).
- **[RAC]**, **[RAE]** indicates amplitude cylinder (R,R).

Specifications

- Maximum working pressure : 20 MPa (2,900 psi)
- Bore × Stroke : 40 mm × 30 mm (1.6 in. × 1.2 in.)
- Weight : 1.5 kg (3.3 lbs.)

3-2-8. Flow divider

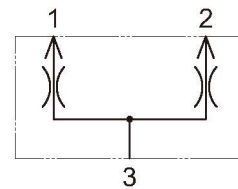
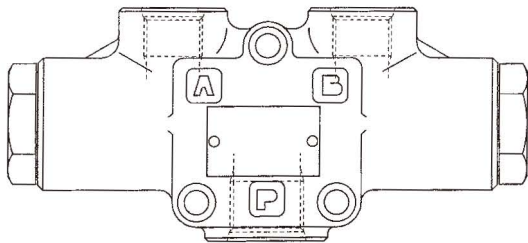
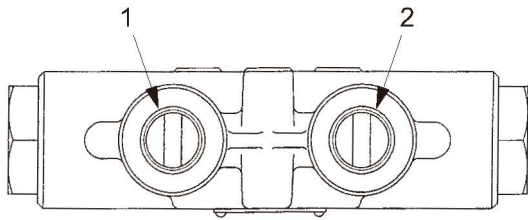

Hydraulic circuit diagram

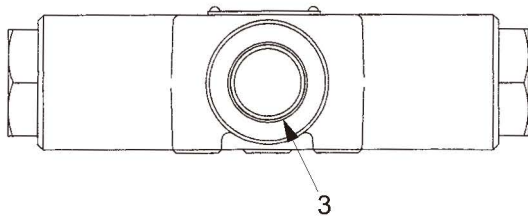

GW751-04013

- (1) Port A **[FDA]** : G3/8
- (2) Port B **[FDB]** : G3/8
- (3) Port P **[FDP]** : G1/2

Specifications

- Rated flow : 40 to 60 L/min (10.6 to 15.9 gal./min)
- Maximum working pressure : 25 MPa (3,625 psi)
- Weight : 1.3 kg (2.9 lbs.)

3-3. Description and Operation of Vibrator System

Description

- Made up of vibrator pump (4), vibrator motor (F) (7), (R,L) (11), (R,R) (14), vibrator solenoid valve (F) (6), (R) (10), amplitude cylinder solenoid valve (F) (18), (R,L) (19), (R,R) (20), amplitude cylinder (F) (8), (R,L) (12), (R,R) (15), vibrator (F) (9), (R,L) (13) and (R,R) (16).

Basic function of vibrator pump and motor

Vibrator pump:

- A fixed displacement gear pump is used. The displacement per rotation of the pump shaft is not variable.

Vibrator motor:

- A fixed displacement piston motor and gear motor are used. The displacement per rotation of the motor shaft is not variable.

Operation

- Amplitude select switch A is select amplitude OFF, amplitude 1 and amplitude 2 to 4.
- Amplitude select switch B is select amplitude 2, amplitude 3 and amplitude 4.
- Amplitude is switching from amplitude 1 to 4 causes vibration at higher amplitude.
- The operation of the amplitude select switch A actuates vibrator select valve (a) and (c) built in vibrator solenoid valve (6) and (10), and the oil discharged from vibrator pump (4) enters vibrator motor (7), (11) and (14).
- Oil fed into the port of the vibrator motor (7), (11) and (14) powers the motor and displaced from the opposite side port, getting back to the hydraulic oil tank.
- In the vibrator circuit, oil from steering • charge pump (5) flows into orbitrol (24), then the oil goes to amplitude cylinder solenoid valve (18), (19) and (20) via hydraulic oil filter 2 (22) irrespective of the steering wheel operation.
- Actuates amplitude select valve (e), (f) and (g) built in amplitude cylinder solenoid valve (18), (19) and (20), and the oil discharged from steering • charge pump (5) enters amplitude cylinder (8), (12) and (15).
- When amplitude select switch A is selected amplitude 2 to 4 and amplitude select switch B is selected amplitude 2 or amplitude 3 or amplitude 4, controls the extend and contract of the rod of the amplitude cylinder.
- By extend and contract the cylinder rod of the amplitude cylinder (8), (12) and (15), the weight of the vibrator (9), (13) and (16) is eccentric and the vibration changes.

Circuit protection against high pressure

- High pressure relief valves (b), (d) built in the vibrator solenoid valve (6), (10) relieve pressure to protect the circuit when the pressure exceeds the setting of the valves.

4. STEERING SYSTEM

4-1. Steering Hydraulic Piping

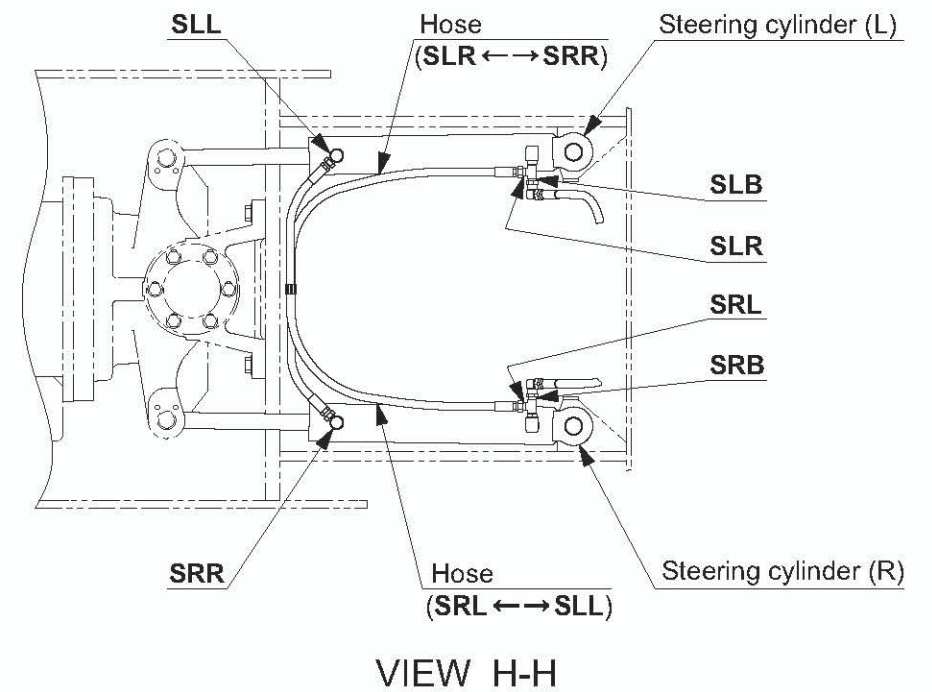
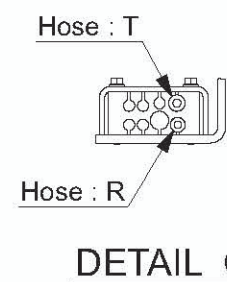
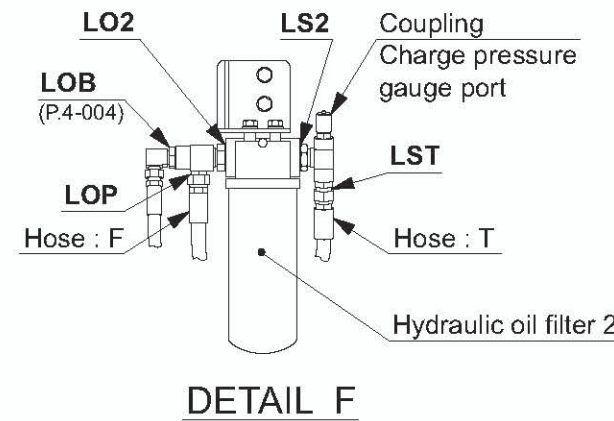
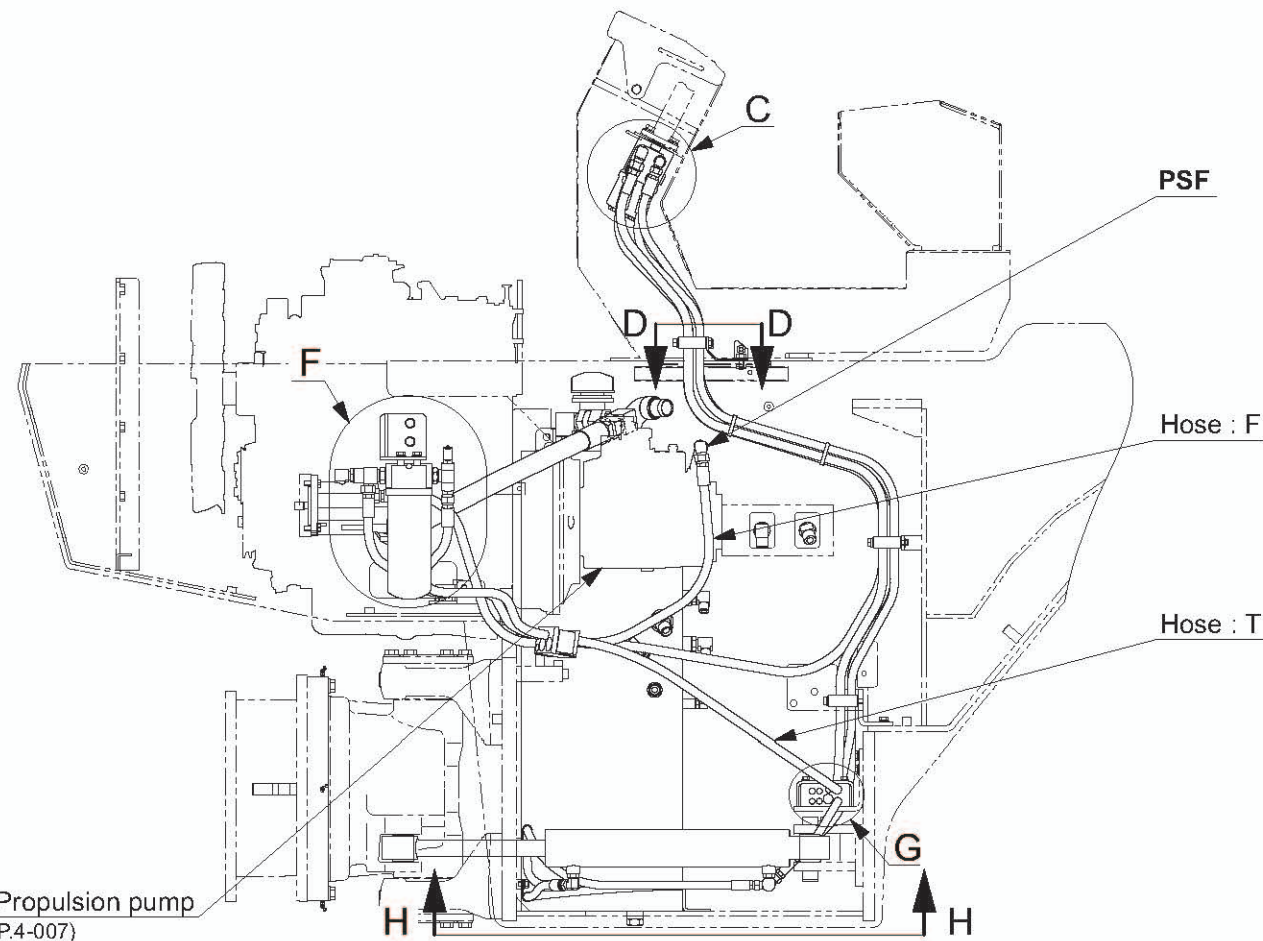
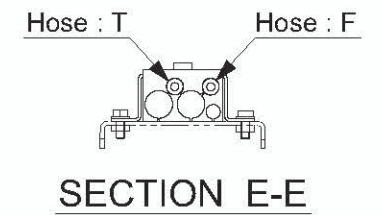
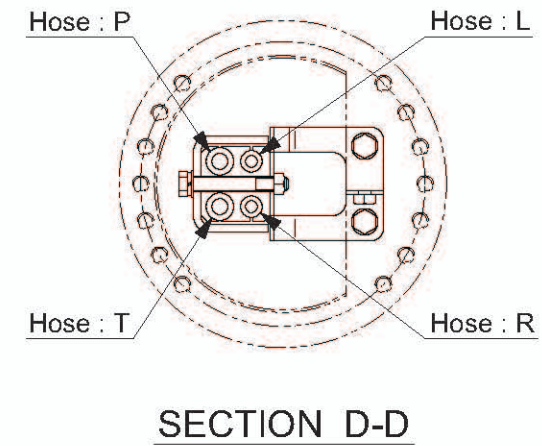
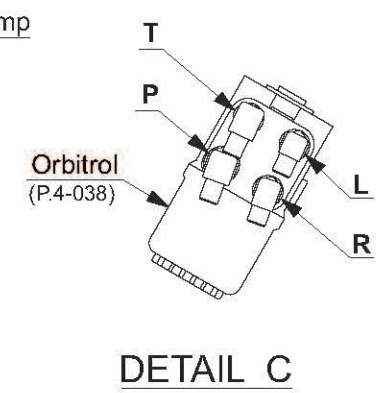
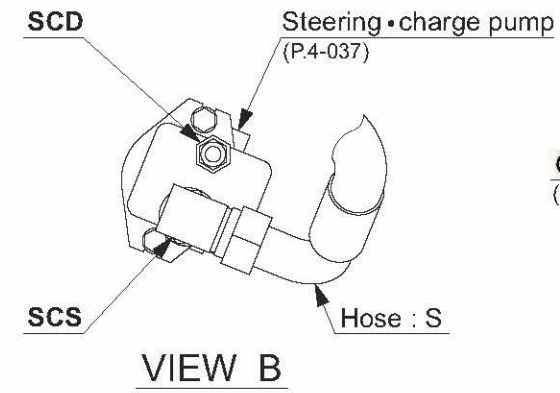
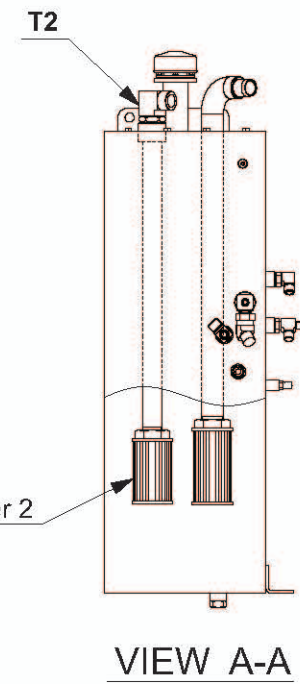
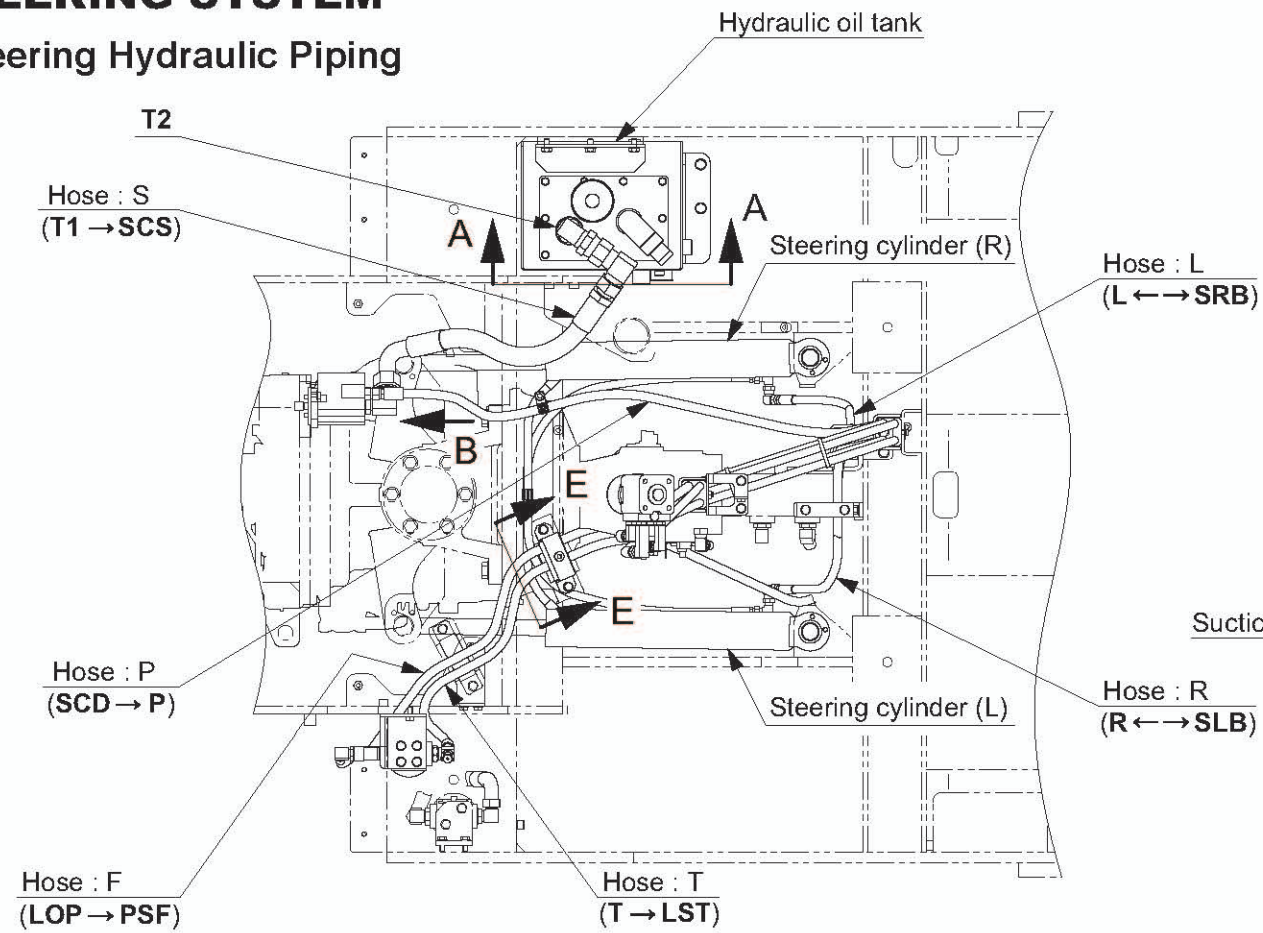

• The letters and numbers in the figure such as "SLR" and "SRR" show each port.
 • Arrow "↔"; "→" symbols show the hose connection and the direction of the flow of the oil.

4-2. Steering Wheel

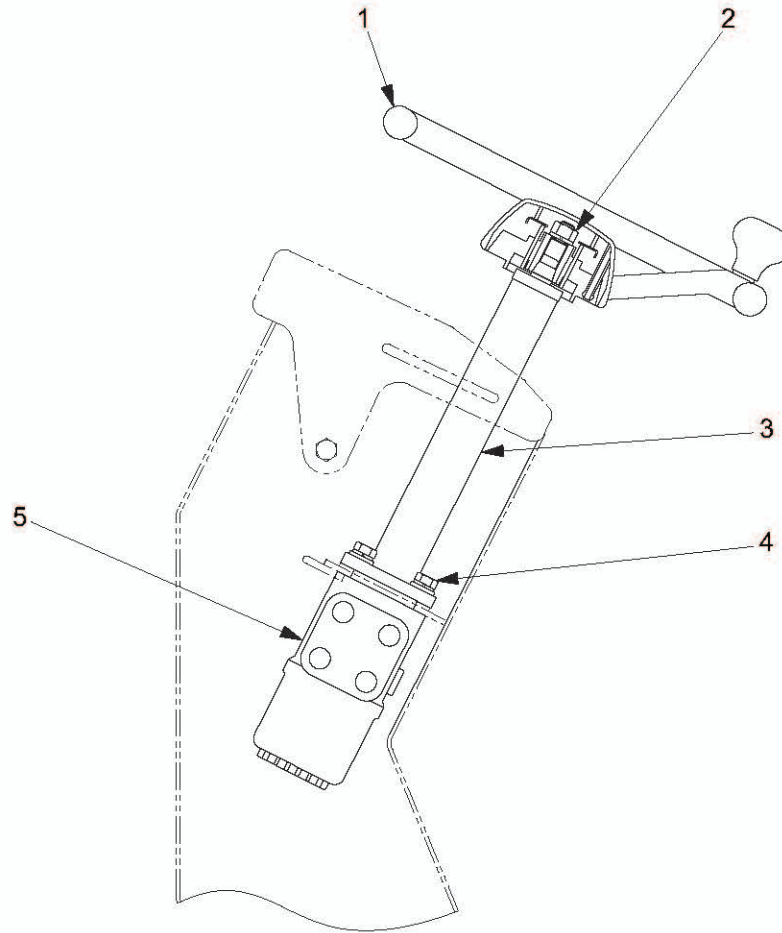

0439-32802-0-10157-0

- (1) Steering wheel
- (2) Nut : M12 P=1.25
- (3) Column shaft
- (4) Bolt : M10×35
- (5) Orbitrol



- (2) Nut M12 P=1.25 : 64 N·m (47 lbf·ft)
- (4) Bolt M10×35 : 49 N·m (36 lbf·ft)

4-3. Hydraulic Component Specifications

4-3-1. Steering • charge pump

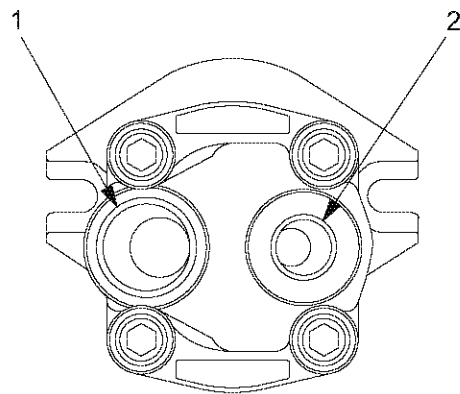
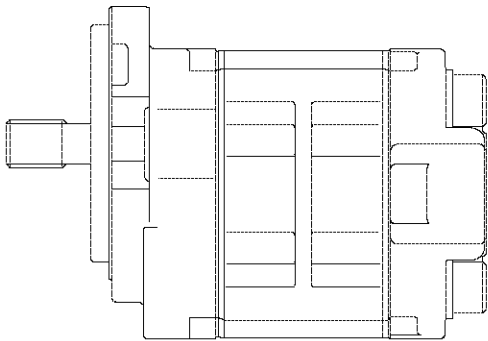

SW770-04005

- (1) Inlet port **[SCS]** : G1
(2) Outlet port **[SCD]** : G1/2

Specifications

- Displacement : 23.7 cm³/rev (1.4 cu.in./rev)
- Rated pressure : 20.6 MPa (2,987 psi)
- Weight : 3.7 kg (8.2 lbs.)

4-3-2. Orbitrol

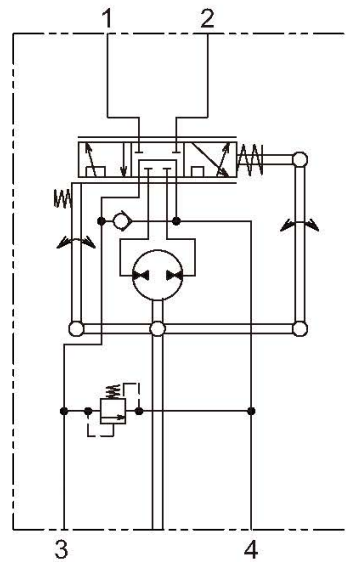
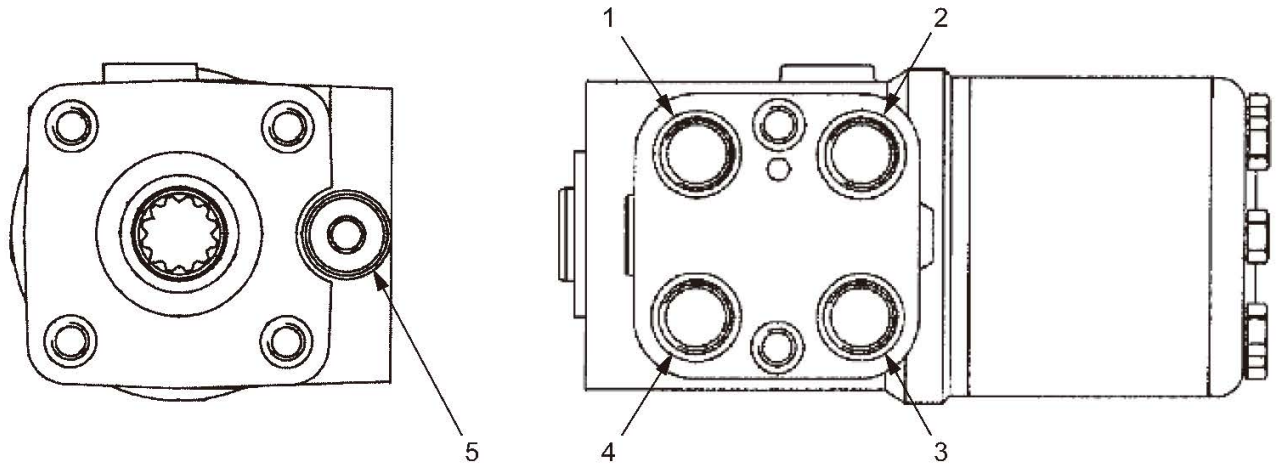

Hydraulic circuit diagram

ORB-SD-04150

- (1) Port L [L] : 3/4-16UNF
- (2) Port R [R] : 3/4-16UNF
- (3) Port P [P] : 3/4-16UNF
- (4) Port T [T] : 3/4-16UNF
- (5) Relief valve

Specifications

- Displacement : 400 cm³/rev (24.4 cu.in./rev)
- Relief valve pressure setting : 15.0 MPa (2,175 psi)
- Weight : 7 kg (15 lbs.)

Fig.: Steering circuit

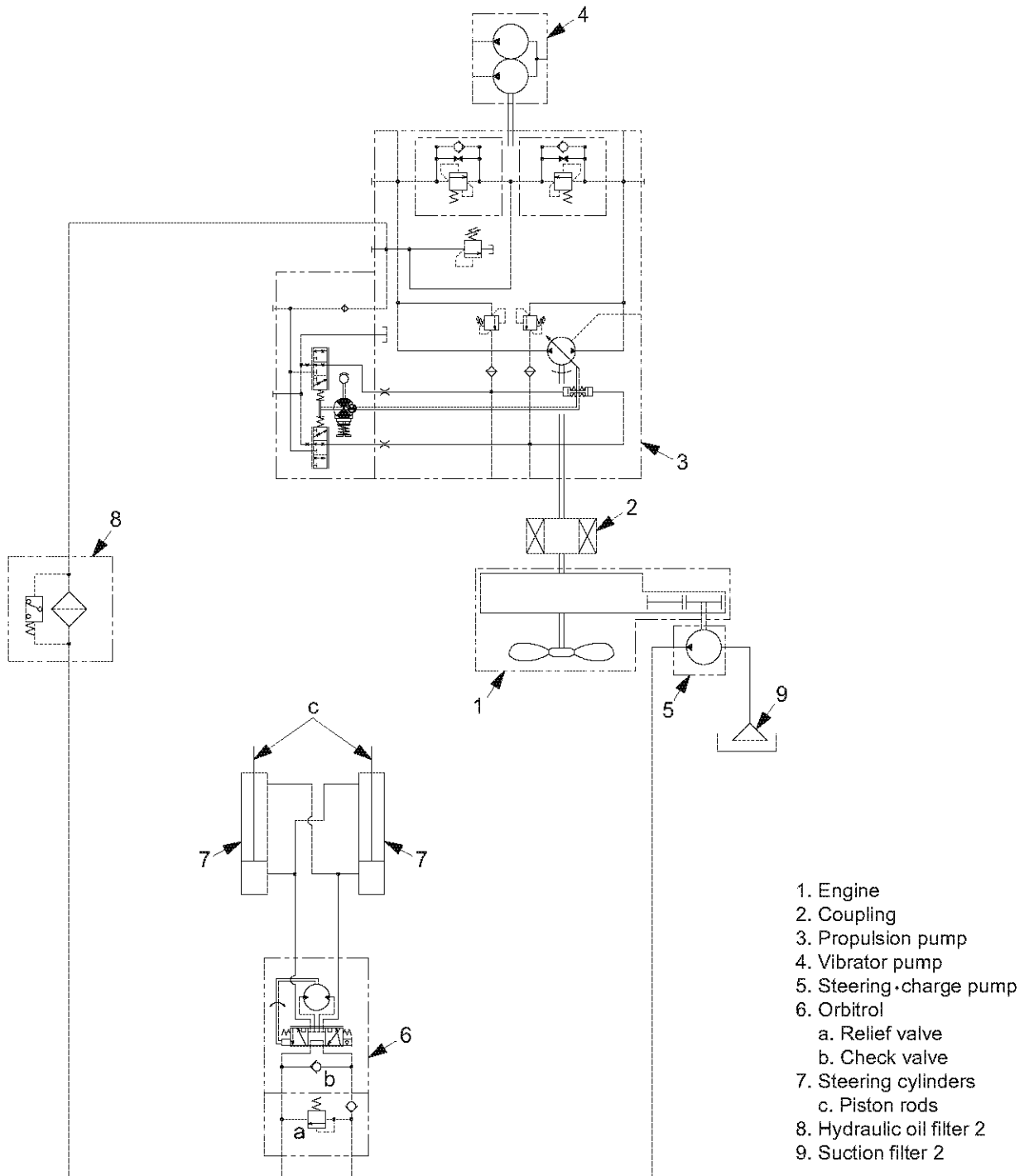

GW754-04014

4-4. Description and Operation of Steering System

4-4-1. Description and operation of steering system

Description

- Made up of steering • charge pump (5), orbitrol (6) steering cylinders (7) and hydraulic oil filter 2 (8). The steering mechanism is of an articulated type in which the machine frame is articulated at its center.

Operation

- The oil discharged from steering • charge pump (5) enters orbitrol (6), and a certain quantity of oil that matches the handle turning direction and speed is supplied to steering cylinders (7).
- The oil that enters the steering cylinder shifts piston rod (c) to operate it, while the oil pushed out of the port on the opposite side returns to orbitrol (6), flowing into the charge circuit of propulsion pump (3) through hydraulic oil filter 2 (8).

- For the "Charge circuit", refer to page 4-018.
- Relief valve (a) built in orbitrol (6) opens to relieve the pressure if the system pressure exceeds the setting of the valve, thus protecting the circuit.

4-4-2. Structure and operation of Orbitrol

- Orbitrol used here is a load-sensing type, in which oil is supplied from the steering hydraulic pump according to the steering wheel rotating speed.

Structure

Valve section:

- The valve is a rotary-type direction changeover valve composed of spool (1) and sleeve (2), and the spline connects the steering wheel to spool (1).
- When the steering wheel is not operated, spool (1) and sleeve (2) are held at the neutral position by centering spring (6), and the oil groove of spool (1) is not aligned with the oil hole of sleeve (2), completely stopping the oil flow into the steering cylinder.
- When the steering wheel is operated, the oil groove of spool (1) is aligned with the oil hole of sleeve (2) to open the circuit, allowing the oil to flow into the steering cylinder.

Rotor section:

- The rotor is a kind of internal gear, functioning as a hydraulic motor when the valve section (spool and sleeve) opens.
- The rotation of rotor (4) is transmitted to the valve section by drive shaft (5), controlling the valve opening according to the steering wheel rotating speed.

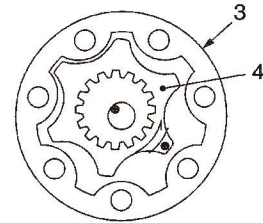
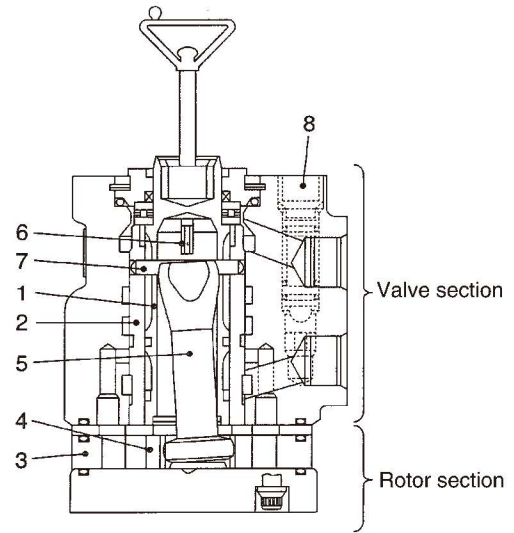

- | | |
|-----------|---------------------|
| 1. Spool | 5. Drive shaft |
| 2. Sleeve | 6. Centering spring |
| 3. Stator | 7. Cross pin |
| 4. Rotor | 8. Check valve |

ORB-SD-04001

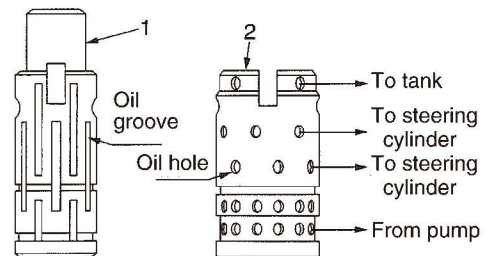

ORB-SD-04002

Operation

Neutral (when the steering wheel is not operated):

- Spool (1) and sleeve (2) in the valve section have a slit respectively, and centering spring (6) is set in the slit in combination with a flat spring.
- When steering wheel is not operated, spool (1) and sleeve (2) are held in the neutral position by centering spring (6).
- This Orbitrol is a load-sensing, non-load reaction normally-closed type valve. All the oil holes of the spool are out of place when Orbitrol is in the neutral position, and the flow of oil from the hydraulic pump into the steering cylinder is closed completely.

Swing (when the steering wheel is operated):

- All the ports of the valve section are closed when Orbitrol is in the neutral position. The oil in the rotor has been sealed up, and rotor (4) is fixed. Sleeve (2) is coupled with rotor (4) via cross pin (7) and drive shaft (5), and it is fixed also.
- When the steering wheel is operated, the turning force is applied to spool (1), contracting centering spring (6) that has been set in the slit. As a result, the oil groove of spool (1) is aligned with the oil hole of sleeve (2), opening the hydraulic circuit.
- Consequently, all the four ports (hydraulic pump, tank, and steering cylinder circuits on the right and left sides) open to permit oil to flow, and rotor (4) rotates.

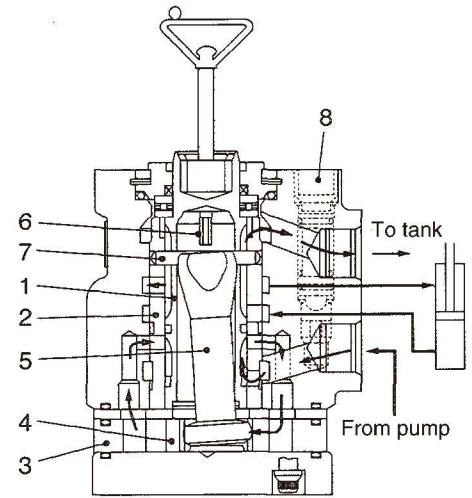

- | | |
|-----------|---------------------|
| 1. Spool | 5. Drive shaft |
| 2. Sleeve | 6. Centering spring |
| 3. Stator | 7. Cross pin |
| 4. Rotor | 8. Check valve |

ORB-SD-04003

Neutral

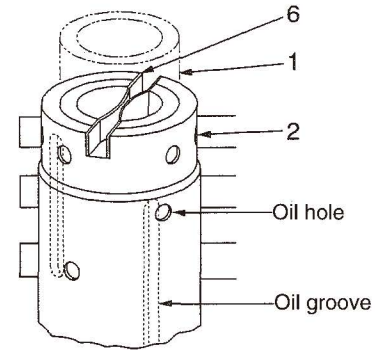

ORB-SD-04004

Swing

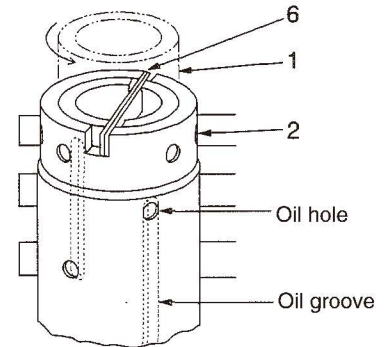

ORB-SD-04005

Operation of feedback mechanism:

- When the steering wheel is operated and the centering spring generates the displacement angle (misalignment in the circumferential direction) between the spool and sleeve, the oil from the hydraulic pump enters Orbitrol to rotate the rotor, and the oil flows into the steering cylinder.
- As a result, the sleeve rotates slightly later than the spool, following the rotation of the spool. This phenomenon permits the spool to rotate continuously, permitting the steering wheel to turn and the vehicle to swing continuously.
- When the steering wheel operation is stopped, the spool stops rotation immediately, but the oil flows into Orbitrol if the displacement angle exists between the spool and sleeve, permitting the rotor to rotate continuously. This rotation allows the sleeve to catch up with the spool, closing the hydraulic circuit. Finally, the centering spring returns the spool and sleeve back to the neutral position, completely stopping the oil flow.

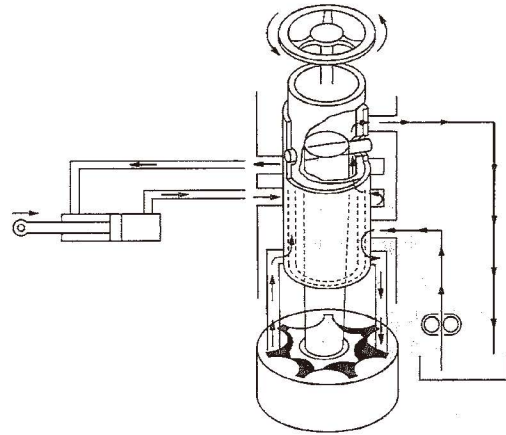

ORB-SD-04006

Steering speed and flow control:

- In the steering mechanism, the flow to the steering cylinder must be increased or decreased according to the rotational speed of the steering wheel.
- Orbitrol controls the flow by changing the displacement angle between spool (1) and sleeve (2). In other words, sleeve (2) follows the rotation of spool (1) during the steering wheel operation, closing the hydraulic circuit.
- When rotational speed of the steering wheel increases, the delay of sleeve (2) (displacement angle) increases, increasing the flow.

Hydraulic pump flow and operating force:

- When the hydraulic pump discharge is sufficient, the steering operating force is used simply to overcome the sliding resistance of sleeve (2) and the rotor, permitting the steering wheel to rotate easily.
- When the hydraulic pump discharge is insufficient, the displacement angle between spool (1) and sleeve (2) reaches the maximum, reducing the quantity of oil flowing from the hydraulic pump into the rotor even if the hydraulic circuit opens widely, causing the rotor to rotate slowly.
- As a result, the spool rotation becomes faster than the rotor rotation to increase the displacement angle to a maximum extent, and the spool rotates the rotor via the cross pin and drive shaft. At that time, the rotor functions as a hydraulic pump, preventing the steering wheel from rotating smoothly.

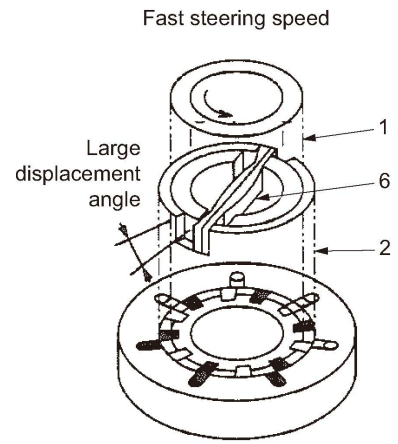
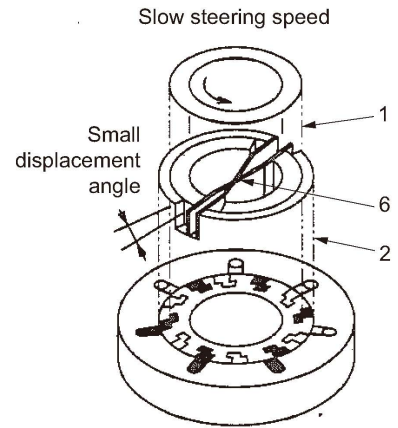

- 1. Spool
- 2. Sleeve
- 6. Centering spring

ORB-SD-04007

ELECTRICAL SYSTEM

1. PRECAUTIONS FOR WORK

1-1. Wire Numbers, Wire Sizes, Wire Colors and Connectors Shown in Electrical Circuit Diagram, Wiring Harness Layout and Wiring Harnesses

- Codes used in electrical circuit diagrams give the following information.
- The wire size is AVS 0.85 unless otherwise specified.

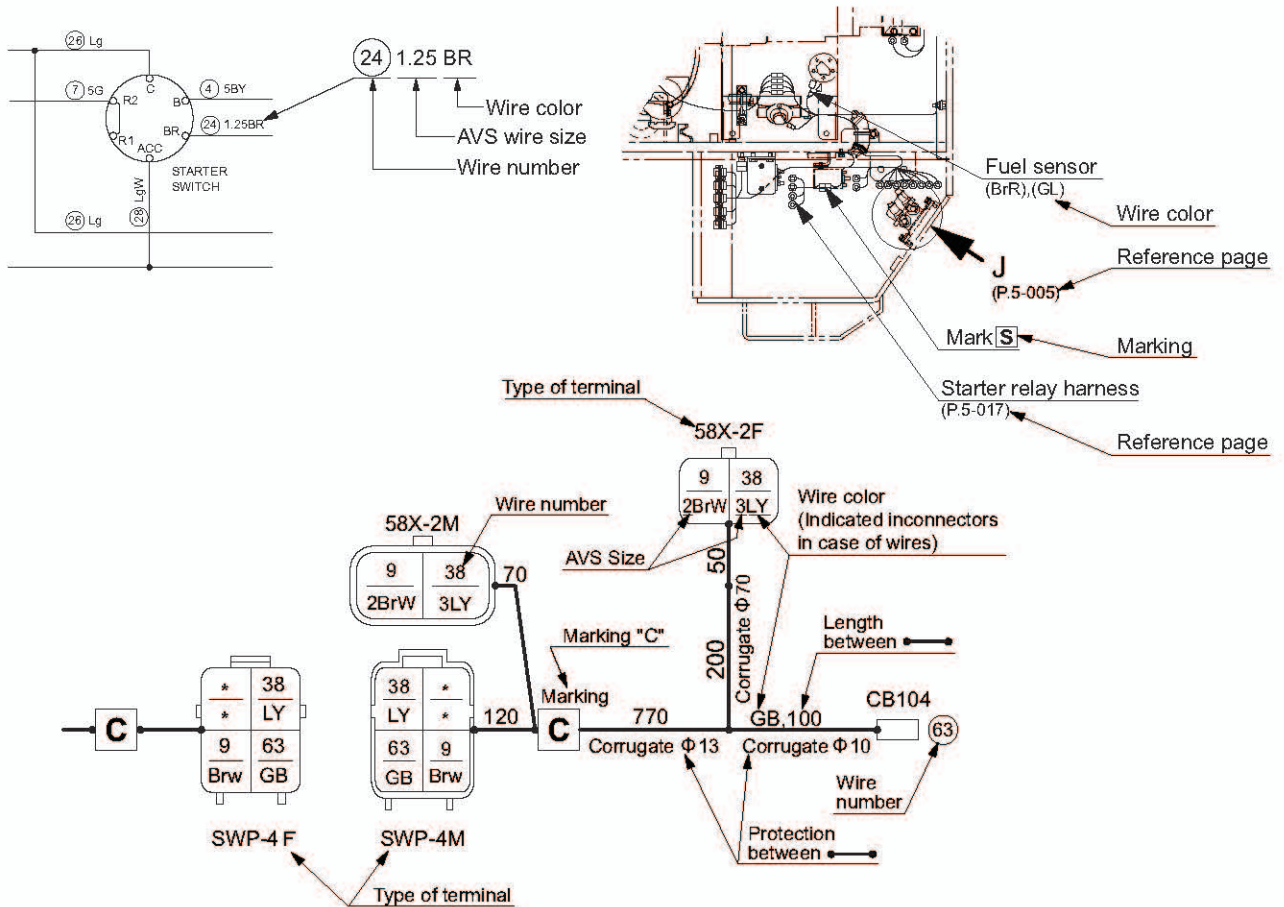

- “*” shows the spare terminal. Plug the seal plug into the place of “*”.
- Connector positions are from connecting side.
- Where the wiring numbers are different, do not be connected with same color either.

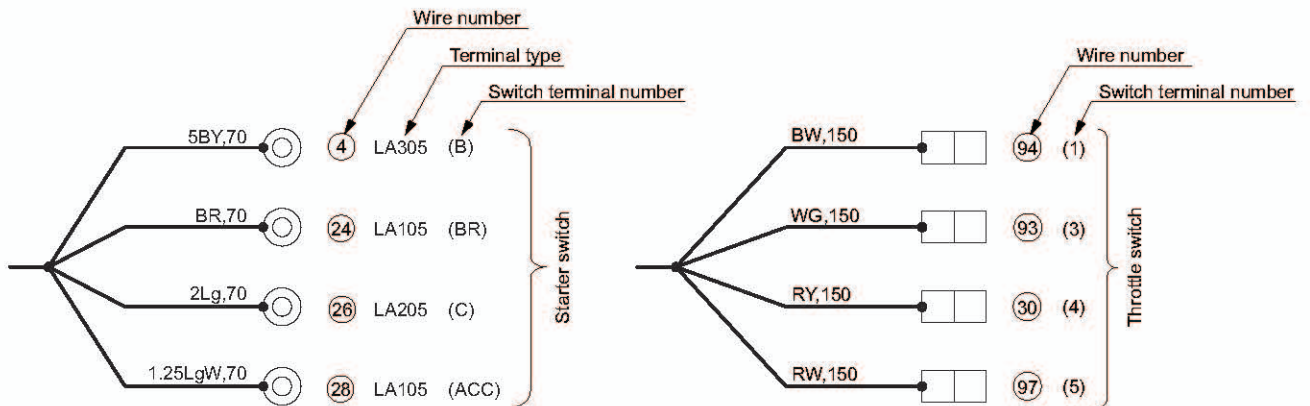

• Wire color code chart

B	Black	BW	Black/ White stripe	BY	Black/ Yellow stripe	BR	Black/ Red stripe	BG	Black/ Green stripe	BL	Black/ Blue stripe			O	Orange	YO	Yellow/ Orange stripe
W	White	WR	White/ Red stripe	WB	White/ Black stripe	WL	White/ Blue stripe	WY	White/ Yellow stripe	WG	White/ Green stripe			OB	Orange/ Black stripe	LO	Blue/ Orange stripe
R	Red	RW	Red/ White stripe	RB	Red/ Black stripe	RY	Red/ Yellow stripe	RG	Red/ Green stripe	RL	Red/ Blue stripe			OW	Orange/ White stripe	GO	Green/ Orange stripe
G	Green	GW	Green/ White stripe	GR	Green/ Red stripe	GY	Green/ Yellow stripe	GB	Green/ Black stripe	GL	Green/ Blue stripe			Gy (Gr)	Gray	GyR (GrR)	Gray/ Red stripe
Y	Yellow	YR	Yellow/ Red stripe	YB	Yellow/ Black stripe	YG	Yellow/ Green stripe	YL	Yellow/ Blue stripe	YW	Yellow/ White stripe					GyL	Gray/ Blue stripe
Br	Brown	BrW	Brown/ White stripe	BrR	Brown/ Red stripe	BrY	Brown/ Yellow stripe	BrB	Brown/ Black stripe	BrG	Brown/ Green stripe	BrL	Brown/ Blue stripe	Sb	Sky blue		
L	Blue	LW	Blue/ White stripe	LR	Blue/ Red stripe	LY	Blue/ Yellow stripe	LB	Blue/ Black stripe	LG	Blue/ Green stripe			P	Pink	PB	Pink/ Black stripe
Lg	Light green	LgR	Light green/ Red stripe	LgY	Light green/ Yellow stripe	LgB	Light green/ Black stripe	LgW	Light green/ White stripe	LgL	Light green/ Blue stripe			Pu	Purple		

2. SYSTEM CIRCUIT DIAGRAM

2-1. Electrical Circuit Diagram

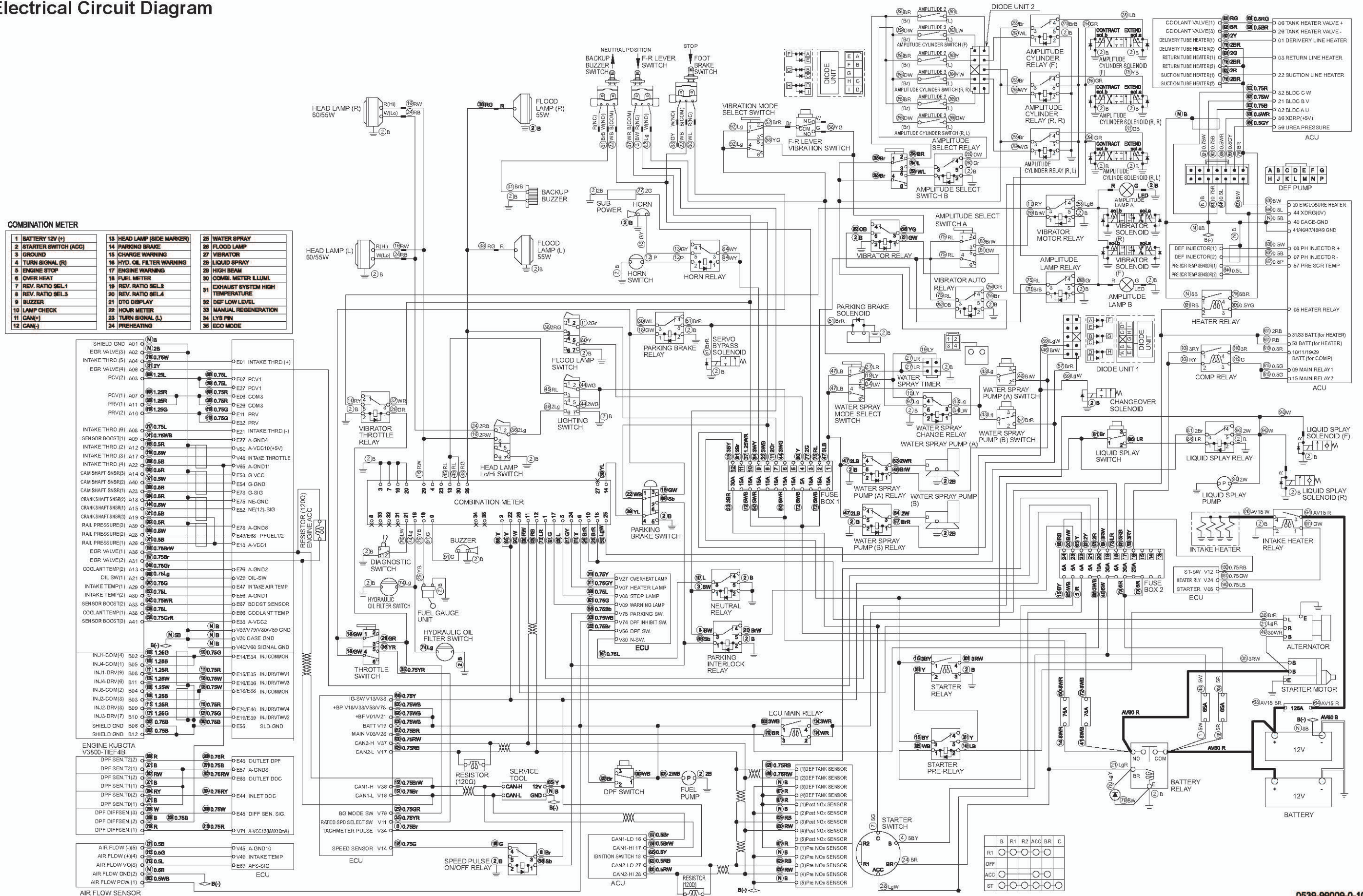

3. ELECTRICAL COMPONENTS

3-1. Wiring Harness Layout (1)

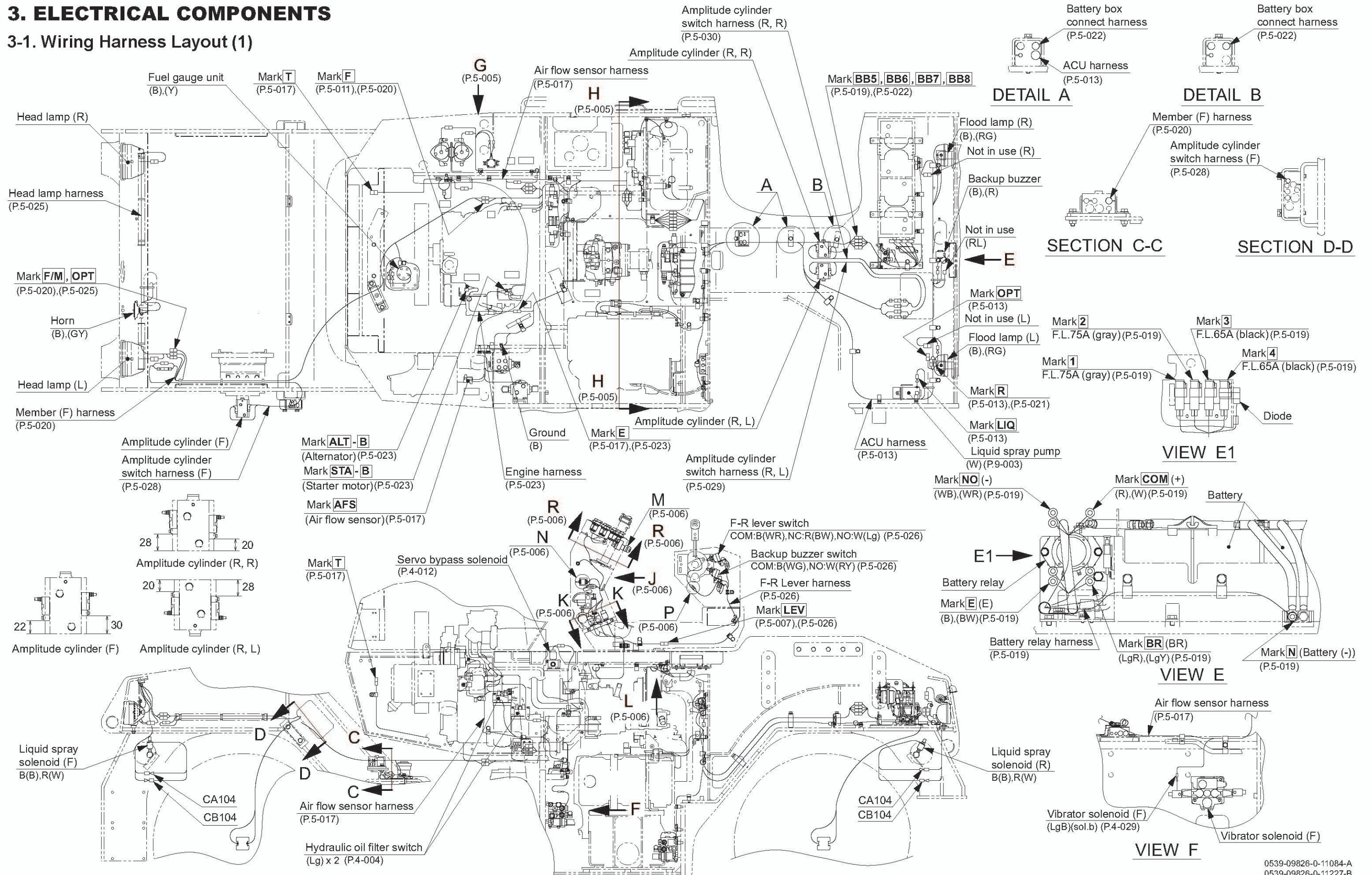

3-2. Wiring Harness Layout (2)

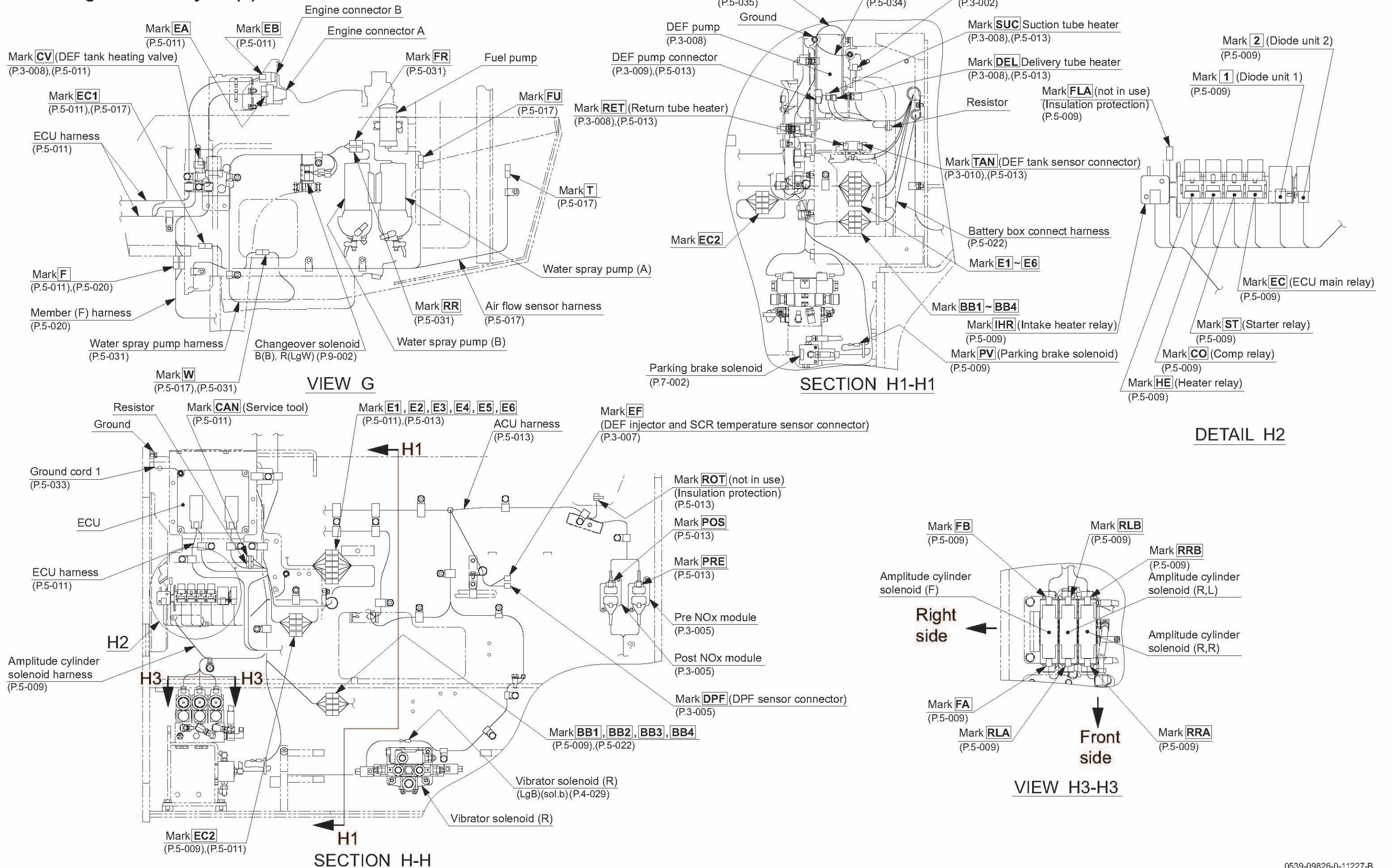

3-3. Wiring Harness Layout (3)

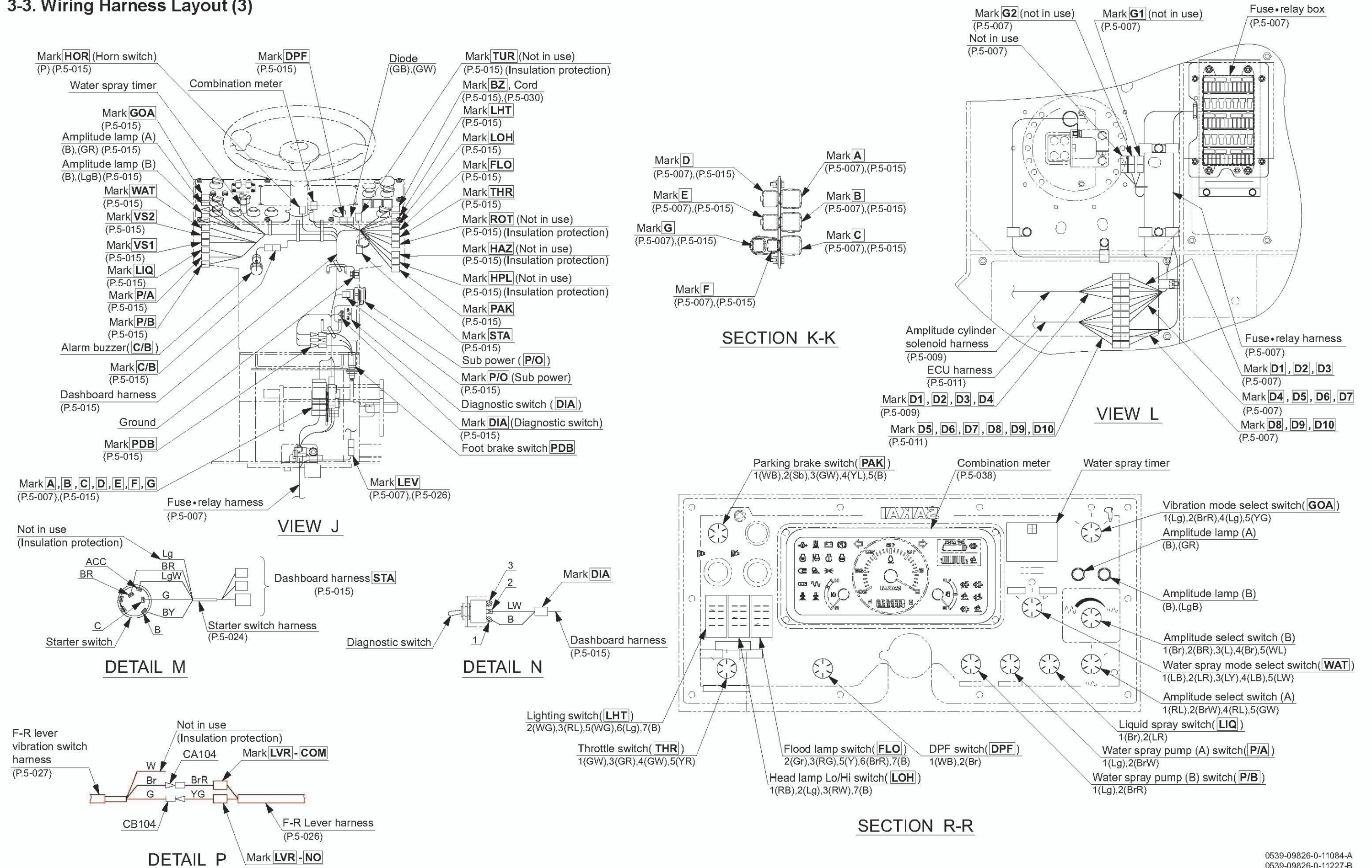

4. WIRING HARNESSSES

4-1. Fuse · Relay Harness

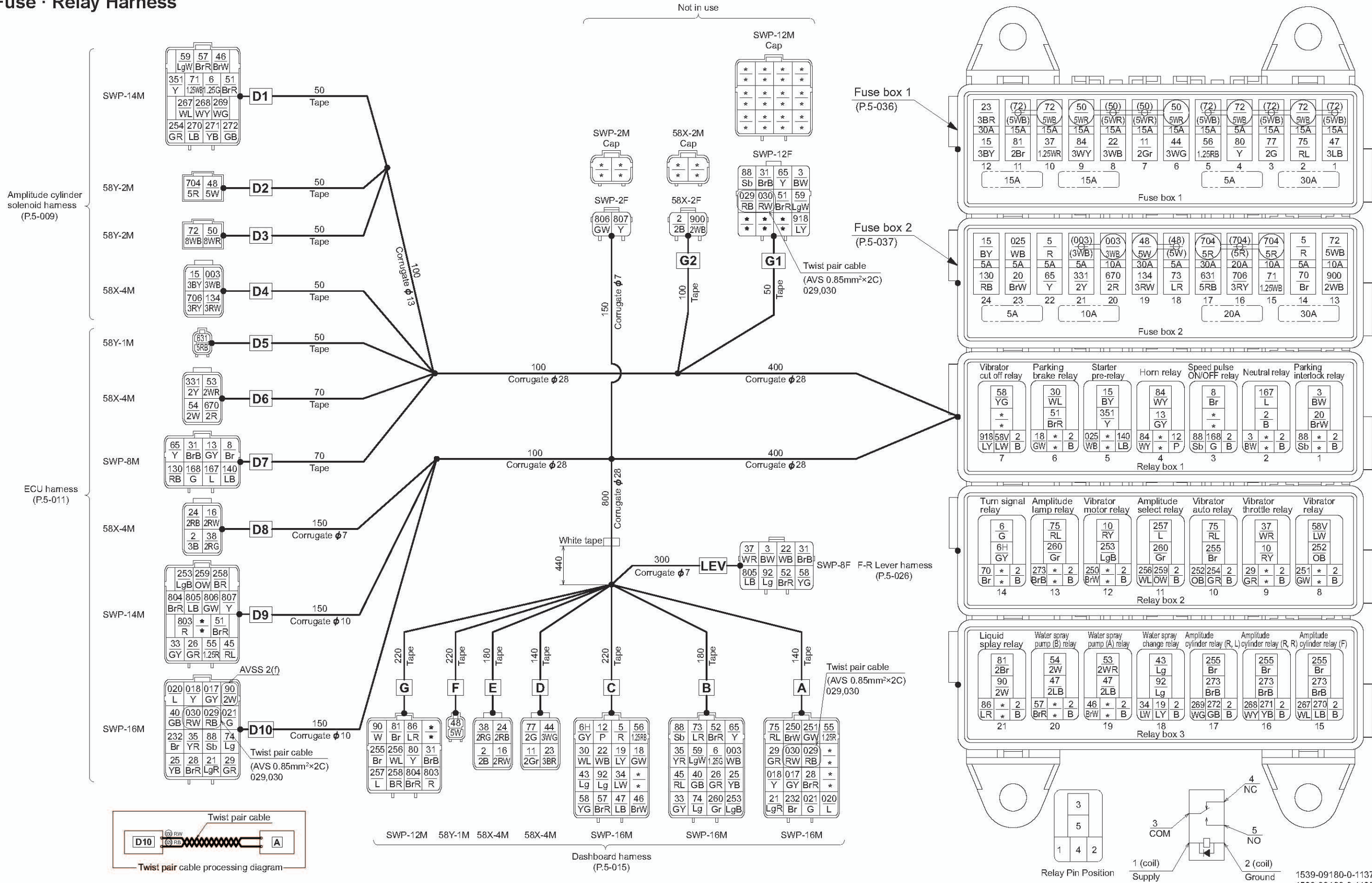

No.	SIZE, COLOR	CONTACT POINTS	CONNECTION
②	B, 2B, 3B	23	D8 , E , Relay box 1-1-2, 1-2-2, -5, 1-3-2, 1-6-2, 1-7-2, 2-8-2, 2-9-2, 2-10-2, 2-11-2, 2-12-2, 2-13-2, 2-14-2, 3-15-2, 3-16-2, 3-17-2, 3-18-2, 3-19-2, 3-20-2, 3-21-2, G2 (not in use)
③	BW	4	LEV , Relay box 1-1-3, 1-2-1, G1 (not in use)
⑤	R	3	C , Fuse box 2-14, 2-22
⑥	G, 1.25G	3	B , D1 , Relay box 2-14-3
⑧	Br	2	D7 , Relay box 1-3-3
⑩	RY	2	Relay box 2-9-5, 2-12-3
⑪	2Gr	2	D , Fuse box 1-7
⑫	P	2	C , Relay box 1-4-2
⑬	GY	2	D7 , Relay box 1-4-5
⑮	BY, 3BY	4	D4 , Fuse box 1-12, 2-24, Relay box 1-5-3
⑯	2RW	2	D8 , E
⑱	GW	2	C , Relay box 1-6-1
⑲	LY	2	C , Relay box 3-18-4
⑳	BrW	2	Fuse box 2-23, Relay box 1-1-5
㉑	LgR	2	A , D10
㉒	WB, 3WB	3	C , LEV , Fuse box 1-8
㉓	3BR	2	D , Fuse box 1-12
㉔	2RB	2	D8 , E
㉕	YB	2	B , D10
㉖	GR	2	B , D9
㉘	BrR	2	A , D10
㉙	GR	3	A , D10 , Relay box 2-9-1
㉚	WL	2	C , Relay box 1-6-3
㉛	BrB	4	D7 , G , LEV , G1 (not in use)
㉜	GY	2	B , D9
㉝	LW	2	C , Relay box 3-18-1
㉞	YR	2	B , D10
㉟	WR, 1.25WR	3	LEV , Fuse box 1-10, Relay box 2-9-3
㊱	2RG	2	D8 , E
㊲	GB	2	B , D10
㊳	Lg	2	C , Relay box 3-18-3
㊴	3WG	2	D , Fuse box 1-6
㊵	RL	2	B , D9
㊶	BrW	3	C , D1 , Relay box 3-19-1
㊷	LB, 2LB, 3LB	4	C , Fuse box 1-1, Relay box 3-19-5, 3-20-5
㊸	5W	3	D2 , F , Fuse box 2-19

No.	SIZE, COLOR	CONTACT POINTS	CONNECTION
⑤①	5WR, 8WR	3	D3 , Fuse box 1-6, -9
⑤②	BrR	4	D1 , D9 , Relay box 1-6-5, G1 (not in use)
⑤③	BrR	2	B , LEV
⑤④	2WR	2	D6 , Relay box 3-19-3
⑤⑤	2W	2	D6 , Relay box 3-20-3
⑤⑥	1.25R	2	A , D9
⑤⑦	1.25RB	2	C , Fuse box 1-5
⑤⑧	BrR	3	C , D1 , Relay box 3-20-1
⑤⑨	YG	3	C , LEV , Relay box 1-7-3
⑤⑩	LgW	3	B , D1 , G1 (not in use)
⑥⑤	Y	4	B , D7 , Fuse box 2-22, G1 (not in use)
⑦①	Br	2	Fuse box 2-14, Relay box 2-14-1
⑦②	1.25WB	2	D1 , Fuse box 2-15
⑦③	5WB, 8WB	5	D3 , Fuse box 1-2, -4, -10, 2-13
⑦④	LR	2	B , Fuse box 2-18
⑦⑤	Lg	2	B , D10
⑦⑥	RL	4	A , Fuse box 1-2, Relay box 2-10-3, 2-13-3
⑦⑦	2G	2	D , Fuse box 1-3
⑦⑧	Y	2	G , Fuse box 1-4
⑦⑨	Br, 2Br	3	G , Fuse box 1-11, Relay box 3-21-3
⑧④	WY, 3WY	3	Fuse box 1-9, Relay box 1-4-1, -3
⑧⑥	LR	2	G , Relay box 3-21-1
⑧⑧	Sb	5	B , D10 , Relay box 1-1-1, 1-3-1, G1 (not in use)
⑨①	W, 2W	3	D10 , G , Relay box 3-21-5,
⑨②	Lg	3	C , LEV , Relay box 3-18-5
⑩③	RB	2	D7 , Fuse box 2-24
⑩④	3RW	2	D4 , Fuse box 2-19
⑩⑦	LB	2	D7 , Relay box 1-5-2
⑩⑧	L	2	D7 , Relay box 1-2-3
⑩⑨	G	2	D7 , Relay box 1-3-4
⑪③	Br	2	A , D10
⑪⑤	BrW	2	A , Relay box 2-12-1
⑪⑥	GW	2	A , Relay box 2-8-1
⑪⑦	OB	2	Relay box 2-8-5, 2-10-1
⑪⑧	LgB	3	B , D9 , Relay box 2-12-5
⑪⑨	GR	2	D1 , Relay box 2-10-4
⑫⑤	Br	5	G , Relay box 2-10-5, 3-15-3, 3-16-3, 3-17-3
⑫⑥	WL	2	G , Relay box 2-11-1
⑫⑦	L	2	G , Relay box 2-11-3

No.	SIZE, COLOR	CONTACT POINTS	CONNECTION
⑫⑧	BR	2	G , D9
⑫⑨	OW	2	D9 , Relay box 2-11-4
⑬①	Gr	3	B , Relay box 2-11-5, 2-13-5
⑬②	WL	2	D1 , Relay box 3-15-1
⑬③	WY	2	D1 , Relay box 3-16-1
⑬④	WG	2	D1 , Relay box 3-17-1
⑬⑤	LB	2	D1 , Relay box 3-15-4
⑬⑥	YB	2	D1 , Relay box 3-16-4
⑬⑦	GB	2	D1 , Relay box 3-17-4
⑬⑧	BrB	4	Relay box 2-13-1, 3-15-5, 3-16-5, 3-17-5
⑬⑨	2Y	2	D6 , Fuse box 2-21
⑭①	Y	2	D1 , Relay box 1-5-5
⑭②	5RB	2	D5 , Fuse box 2-17
⑭③	2R	2	D6 , Fuse box 2-20
⑭④	5R	3	D2 , Fuse box 2-15, -17
⑭⑤	3RY	2	D4 , Fuse box 2-16
⑭⑥	R	2	G , D9
⑭⑦	BrR	2	G , D9
⑭⑧	LB	2	D9 , LEV
⑭⑨	GW	2	D9 , Mihaal (option)
⑮①	Y	2	D9 , Mihaal (option)
⑮②	2WB	2	Fuse box 2-13, G2 (not in use)
⑮③	LY	2	Relay box 1-7-1, G1 (not in use)
⑮④	WB, 3WB	3	B , D4 , Fuse box 2-20
⑮⑤	GY	2	A , D10
⑮⑥	Y	2	A , D10
⑮⑦	L	2	A , D10
⑮⑧	G	2	A , D10
⑮⑨	WB	2	Fuse box 2-23, Relay box 1-5-1
⑯①	RB	3	A , D10 , G1 (not in use)
⑯②	RW	3	A , D10 , G1 (not in use)
⑯③	GY	2	C , Relay box 2-14-5
⑯④	LW	2	Relay box 1-7-4, 2-8-3

4-2. Amplitude Cylinder Solenoid Harness

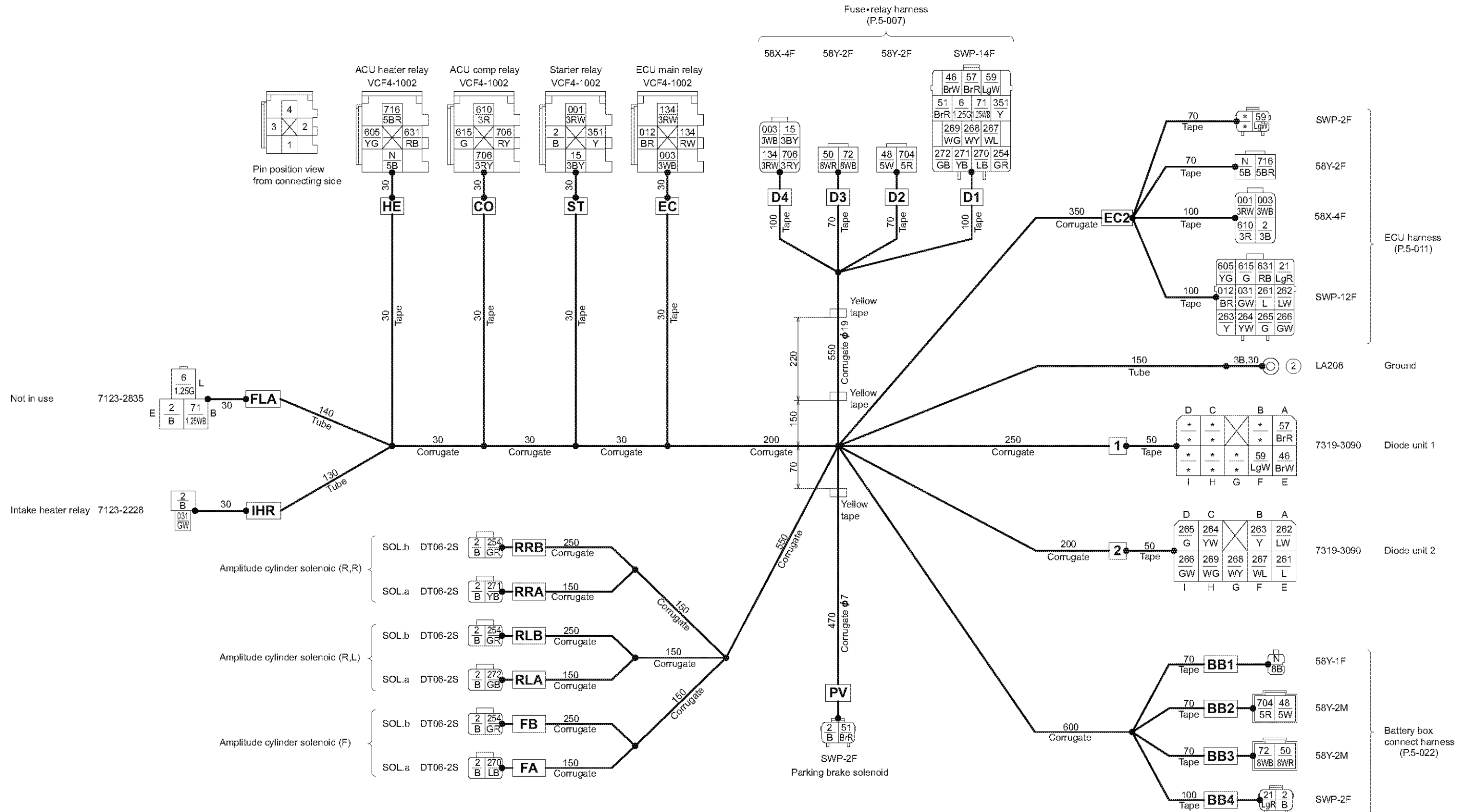

No.	SIZE, COLOR	CONTACT POINTS	CONNECTION
(N)	5B, 8B	3	BB1 , EC2 (2F), HE
(2)	B, 3B	13	BB4 , EC2 (4F), FA , FB , IHR , PV , RLA , RLB , RRR , RRB , ST , Ground, FLA (not in use)
(6)	1.25G	2	D1 , FLA (not in use)
(15)	3BY	2	D4 , ST
(21)	LgR	2	BB4 , EC2 (12F)
(46)	BrW	2	D1 , 1
(48)	5W	2	D2 , BB2
(50)	8WR	2	D3 , BB3
(51)	BrR	2	D1 , PV
(57)	BrR	2	D1 , 1
(59)	LgW	3	D1 , 1 , EC2 (2F)
(71)	1.25WB	2	D1 , FLA (not in use)
(72)	8WB	2	D3 , BB3
(134)	RW, 3RW	3	D4 , EC × 2
(254)	GR	4	D1 , FB , RLB , RRB
(261)	L	2	EC2 (12F), 2
(262)	LW	2	EC2 (12F), 2
(263)	Y	2	EC2 (12F), 2
(264)	YW	2	EC2 (12F), 2

No.	SIZE, COLOR	CONTACT POINTS	CONNECTION
(265)	G	2	EC2 (12F), 2
(266)	GW	2	EC2 (12F), 2
(267)	WL	2	D1 , 2
(268)	WY	2	D1 , 2
(269)	WG	2	D1 , 2
(270)	LB	2	D1 , FA
(271)	YB	2	D1 , RRR
(272)	GB	2	D1 , RLA
(351)	Y	2	D1 , ST
(605)	YG	2	EC2 (12F), HE
(610)	3R	2	CO , EC2 (4F)
(615)	G	2	CO , EC2 (12F)
(631)	RB	2	EC2 (12F), HE
(704)	5R	2	D2 , BB2
(706)	RY, 3RY	3	CO × 2, D4
(716)	5BR	2	EC2 (2F), HE
(001)	3RW	2	EC2 (4F), ST
(003)	3WB	3	D4 , EC , EC2 (4F)
(012)	BR	2	EC , EC2 (12F)
(031)	GW	2	EC2 (12F), IHR

No.	SIZE, COLOR	CONTACT POINTS	CONNECTION
(N)	B, 2B, 3B, 5B	13	CAN, EA-1, -2, EC1 (12F), EC2 (2M), E3, ECU-V20, -V39, -V40, -V59, -V60, -V79, -V80
(2)	B, 1.25B, 2B, 3B	7	D8, EC1 (12F), EC2 (4M), E4, F (3F), Ground, Servo bypass solenoid
(8)	Br	2	D7, ECU-V34
(13)	GY	2	D7, F (12F)
(16)	2RW	2	D8, F (3F)
(21)	LgR	3	D10, EC1 (12F), EC2 (12M)
(24)	2RB	2	D8, F (3F)
(25)	YB	2	D10, F (12F)
(26)	GR	3	D9, EC1 (12F), E2
(28)	BrR	2	D10, EC1 (12F)
(29)	GR	2	D10, ECU-V76
(31)	BrB	2	D7, E2
(33)	GY	2	D9, E2
(35)	YR	2	D10, ECU-V11
(38)	2RG	2	D8, E4
(40)	GB	3	D10, EC1 (12F), E2
(45)	RL	3	D9, EC1 (12F), E2
(51)	BrR	2	D9, Servo bypass solenoid
(53)	2WR	2	D6, EC1 (4F)
(54)	2W	2	D6, EC1 (4F)
(55)	1.25R	2	D9, E3
(59)	LgW	2	EC1 (2F), EC2 (2M)
(65)	Y	5	CAN, D7, E1, ECU-V13, -V33
(74)	Lg	2	D10, EC1 (12F)
(88)	Sb	2	D10, ECU-V75
(90)	W, 2W	3	D10, E1, F (12F)
(100)	G, 1.25G	4	3 EB-2, ECU-E14, -E34
	1.25B		1 EB-5
(106)	W, 1.25W	4	3 EB-4, ECU-E18, -E38
	1.25B		1 EB-3
(111)	R, 1.25R	3	EB-8, ECU-E15, -E35
(115)	R, 1.25R	3	EB-9, ECU-E20, -E40
(121)	G, 1.25G	3	EB-10, ECU-E19, -E39
(125)	W, 1.25W	3	EB-11, ECU-E16, -E36
(130)	RB	2	D7, ECU-V12

No.	SIZE, COLOR	CONTACT POINTS	CONNECTION
(140)	LB	2	D7, ECU-V05
(144)	0.5W	2	EA-15, ECU-E52
(157)	Br	4	CAN, EA-31, E2, ECU-V16
(158)	BrW	4	CAN, EA-36, E2, ECU-V36
(163)	0.5R	2	EA-12, ECU-V50
(167)	L	2	D7, ECU-V30
(168)	G	2	D7, ECU-V14
(200)	R	2	E2, ECU-E43
(201)	B	2	E2, ECU-E57
(202)	RW	2	E2, ECU-E63
(204)	RY	2	E2, ECU-E44
(208)	W	2	E2, ECU-E45
(209)	B, 0.5B	3	E2, EA-22, ECU-V65
(210)	R	2	E2, ECU-V71
(211)	B	2	EC1 (12F), ECU-V45
(212)	G	2	EC1 (12F), ECU-V49
(213)	L	2	EC1 (12F), ECU-E69
(216)	W	2	EA-4, ECU-E01
(217)	L	2	EA-8, ECU-E21
(219)	0.5W	2	EA-17, ECU-V48
(232)	Br	2	D10, ECU-V56
(253)	LgB	3	E6, EC1 (12F), D9
(258)	BR	3	D9, E6, F (12F)
(259)	OW	3	D9, E6, F (12F)
(261)	L	2	EC2 (12M), F (12F)
(262)	LW	2	EC2 (12M), F (12F)
(263)	Y	2	EC2 (12M), E6
(264)	YW	2	EC2 (12M), E6
(265)	G	2	EC2 (12M), E6
(266)	GW	2	EC2 (12M), E6
(331)	2Y	2	D6, EA-6
(500)	R, 1.25R	4	EA-7, -11, ECU-E06, -E26
(509)	L, 1.25L	3	EA-3, ECU-E07, -E27
(510)	G, 1.25G	3	EA-10, ECU-E11, -E32
(605)	YG	2	EC2 (12M), E6
(606)	RG	2	CV, E6
(610)	3R	2	EC2 (4M), E3

No.	SIZE, COLOR	CONTACT POINTS	CONNECTION
(615)	G	2	EC2 (12M), E2
(626)	BR	2	CV, E2
(631)	RB, 5RB	3	D5, EC2 (12M), E5
(670)	2R	2	D6, E3
(716)	5BR	2	EC2 (2M), E5
(803)	R	2	D9, E6
(804)	BrR	3	D9, E6, F (12F)
(805)	LB	2	D9, F (12F)
(806)	GW	2	D9, F (12F)
(807)	Y	2	D9, E6
(001)	3RW	2	EC1 (4F), EC2 (4M)
(002)	B	3	EB-6, 12, ECU-E55
(003)	WB, 2WB, 3WB	10	EC1 (4F), EC2 (4M), ECU-V01, -V18, -V19, -V21, -V38, -V58, -V74, -V78
(012)	BR	3	EC2 (12M), ECU-V03, -V23
(017)	GY	2	D10, ECU-V07
(018)	Y	2	D10, ECU-V27
(020)	L	2	D10, ECU-V08
(021)	G	2	D10, ECU-V09
(029)	RB	4	D10, E1, ECU-V17, Resistor (120Ω)
(030)	RW	4	D10, E1, ECU-V37, Resistor (120Ω)
(031)	GW	2	EC2 (12M), ECU-V24
(038)	GrR	2	EA-41, ECU-E33
(039)	L	2	EA-38, ECU-E66
(040)	Gr	2	EA-13, ECU-E76
(041)	WB	2	EA-9, ECU-E77
(042)	WR	2	EA-33, ECU-E67
(052)	G	2	EA-29, ECU-E47
(053)	L	2	EA-30, ECU-E56
(060)	Lg	2	EA-21, ECU-V29
(061)	0.5B	3	EA-19, -26, ECU-E13
(063)	0.5R	2	EA-39, ECU-E78
(066)	0.5W	3	EA-28, ECU-E49, -E68
(090)	0.5B	2	EA-23, ECU-E73
(091)	0.5W	2	EA-40, ECU-E54
(092)	0.5R	2	EA-14, ECU-E53
(094)	0.5R	2	EA-18, ECU-E75

4-4. ACU Harness

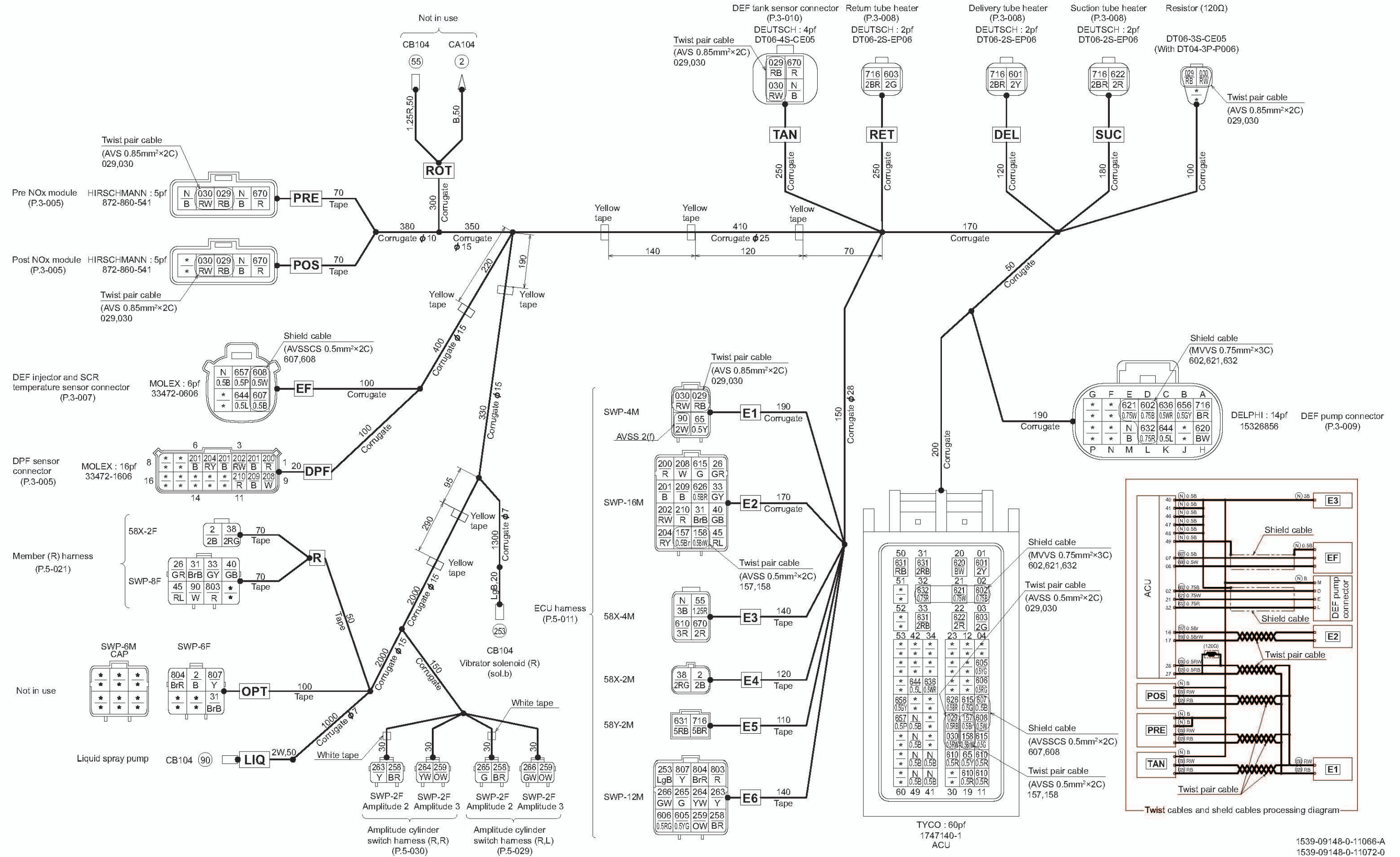

No.	SIZE, COLOR	CONTACT POINTS	CONNECTION
(N)	B, 0.5B, 3B	13	EF , E3 , POS , PRE × 2, TAN , ACU-40, -41, -46, -47, -48, -49, DEF pump connector-M
(2)	B, 2B	4	E4 , R , OPT (not in use), ROT (not in use)
(26)	GR	2	E2 , R
(31)	BrB	3	E2 , R , OPT (not in use)
(33)	GY	2	E2 , R
(38)	2RG	2	E4 , R
(40)	GB	2	E2 , R
(45)	RL	2	E2 , R
(55)	1.25R	2	E3 , ROT (not in use)
(65)	0.5Y	2	E1 , ACU-18
(90)	W, 2W	3	E1 , R , LIQ
(157)	0.5Br	2	E2 , ACU-16
(158)	0.5BrW	2	E2 , ACU-17
(200)	R	2	E2 , DPF -1
(201)	B	4	E2 , DPF -2, -4, -6
(202)	RW	2	E2 , DPF -3
(204)	RY	2	E2 , DPF -5
(208)	W	2	E2 , DPF -9
(209)	B	2	E2 , DPF -10
(210)	R	2	E2 , DPF -11
(253)	LgB	2	E6 , Vibrator solenoid (R)
(258)	BR	3	E6 , Amplitude cylinder switch harness (R, L)-2, (R, R)-2
(259)	OW	3	E6 , Amplitude cylinder switch harness (R, L)-3, (R, R)-3
(263)	Y	2	E6 , Amplitude cylinder switch harness (R, R)-2
(264)	YW	2	E6 , Amplitude cylinder switch harness (R, R)-3
(265)	G	2	E6 , Amplitude cylinder switch harness (R, L)-2

No.	SIZE, COLOR	CONTACT POINTS	CONNECTION
(266)	GW	2	E6 , Amplitude cylinder switch harness (R, L)-3
(601)	2Y	2	DEL , ACU-01
(602)	0.75B	2	ACU-02, DEF pump connector-D
(603)	2G	2	RET , ACU-03
(605)	0.5YG	2	E6 , ACU-05
(606)	0.5RG	2	E6 , ACU-06
(607)	0.5B	2	EF , ACU-07
(608)	0.5W	2	EF , ACU-08
(610)	0.5R, 3R	5	E3 , ACU-10, -11, -19, -29
(615)	G, 0.5G	3	E2 , ACU-09, -15
(620)	BW	2	ACU-20, DEF pump connector-H
(621)	0.75W	2	ACU-21, DEF pump connector-E
(622)	2R	2	SUC , ACU-22
(626)	0.5BR	2	E2 , ACU-26
(631)	RB, 2RB, 5RB	4	E5 , ACU-31, -33, -50
(632)	0.75R	2	ACU-32, DEF pump connector-L
(636)	0.5WR	2	ACU-36, DEF pump connector-C
(644)	0.5L	3	EF , ACU-44, DEF pump connector-K
(656)	0.5GY	2	ACU-56, DEF pump connector-B
(657)	0.5P	2	EF , ACU-57
(670)	R, 2R	4	E3 , POS , PRE , TAN
(716)	BR, 2BR, 5BR	5	DEL , E5 , RET , SUC , DEF pump connector-A
(803)	R	2	E6 , R
(804)	BrR	2	E6 , OPT (not in use)
(807)	Y	2	E6 , OPT (not in use)
(029)	RB, 0.5RB	6	E1 , POS , PRE , TAN , ACU-27, Resistor (120Ω)
(030)	RW, 0.5RW	6	E1 , POS , PRE , TAN , ACU-28, Resistor (120Ω)

4-5. Dashboard Harness

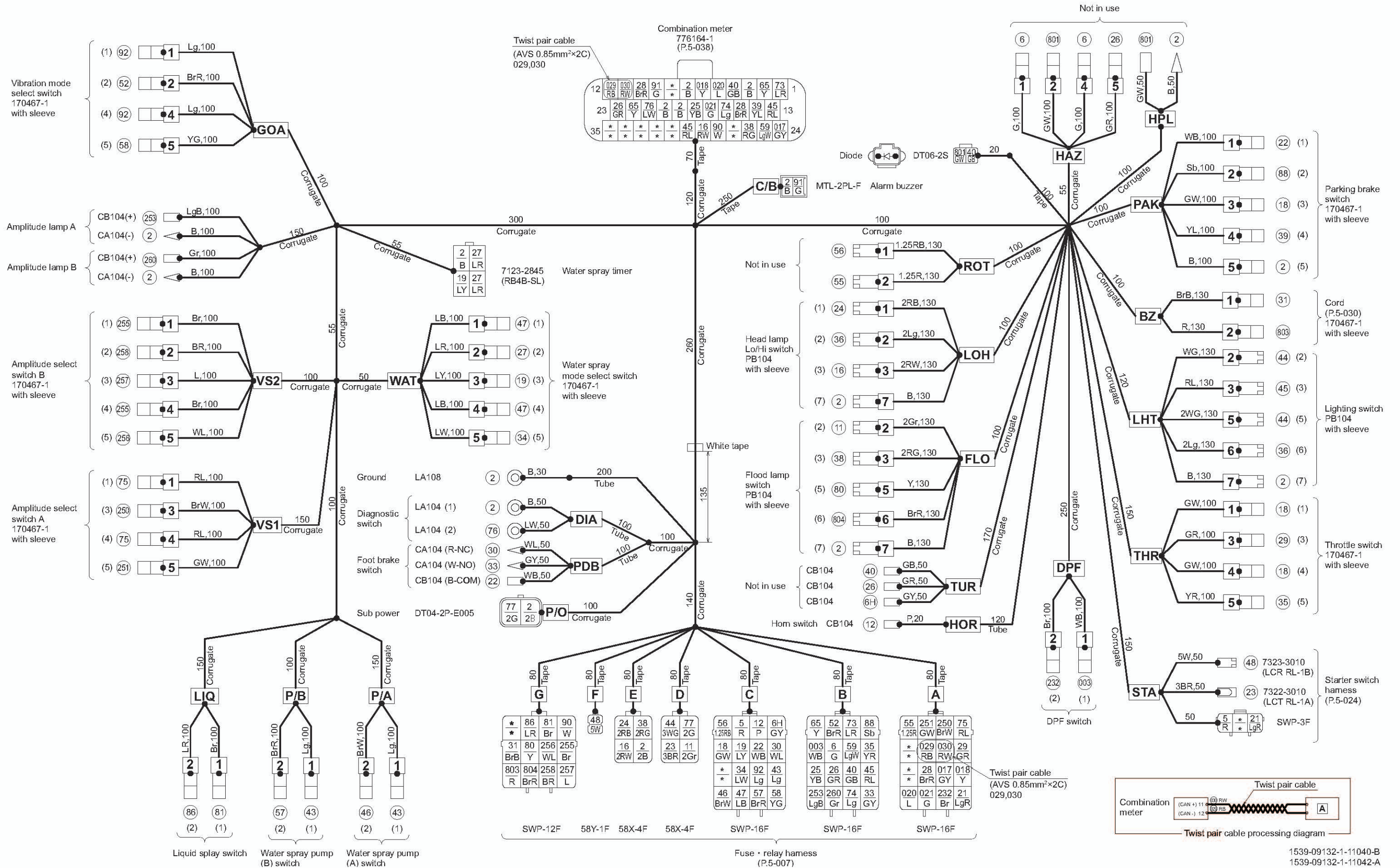

No.	SIZE, COLOR	CONTACT POINTS	CONNECTION
②	B, 2B	17	C/B, DIA, E, FLO-7, LHT-7, LOH-7, PAK-5, P/O, Amplitude lamp A, B, Combination meter-3, -7, -19, -20, Ground, Water spray timer, HPL (not in use)
⑤	R	2	C, STA
⑥	G	3	B, HAZ-1, -4 (not in use)
⑪	2Gr	2	D, FLO-2
⑫	P	2	C, HOR
⑯	RW, 2RW	3	E, LOH-3, Combination meter-29
⑱	GW	4	C, PAK-3, THR-1, -4
⑲	LY	3	C, WAT-3, Water spray timer
⑳	LgR	2	A, STA
㉑	WB	3	C, PAK-1, PDB
㉒	3BR	2	D, STA
㉓	2RB	2	E, LOH-1
㉔	YB	2	B, Combination meter-18
㉕	GR	4	B, Combination meter-23, HAZ-5, TUR (not in use)
㉖	LR	3	WAT-2, Water spray timer × 2
㉗	BrR	3	A, Combination meter-10, -15
㉘	GR	2	A, THR-3
㉙	WL	2	C, PDB
㉚	BrB	2	G, BZ-1 (not in use)
㉛	GY	2	B, PDB
㉜	LW	2	C, WAT-5
㉝	YR	2	B, THR-5
㉞	2Lg	2	LHT-6, LOH-2
㉟	RG, 2RG	3	E, FLO-3, Combination meter-26
㊱	YL	2	PAK-4, Combination meter-14
㊲	GB	4	B, Combination meter-4, Diode, TUR (not in use)
㊳	Lg	3	C, P/A-1, P/B-1
㊴	WG, 2WG, 3WG	3	D, LHT-2, -5
㊵	RL	4	B, LHT-3, Combination meter-13, -30
㊶	BrW	2	C, P/A-2
㊷	LB	3	C, WAT-1, -4
㊸	5W	2	F, STA
㊹	BrR	2	B, GOA-2
㊺	1.25R	2	A, ROT-2
㊻	1.25RB	2	C, ROT-1

No.	SIZE, COLOR	CONTACT POINTS	CONNECTION
⑤⑦	BrR	2	C, P/B-2
⑤⑧	YG	2	C, GOA-5
⑤⑨	LgW	2	B, Combination meter-25
⑥⑤	Y	3	B, Combination meter-2, -22
⑦③	LR	2	B, Combination meter-1
⑦④	Lg	2	B, Combination meter-16
⑦⑤	RL	3	A, VS1-1, -4
⑦⑥	LW	2	DIA, Combination meter-21
⑦⑦	2G	2	D, P/O
⑧①	Y	2	FLO-5, G
⑧①	Br	2	G, LIQ-1
⑧⑥	LR	2	G, LIQ-2
⑧⑧	Sb	2	B, PAK-2
⑨①	W	2	G, Combination meter-28
⑨①	G	2	C/B, Combination meter-9
⑨②	Lg	3	C, GOA-1, -4
⑩③	Br	2	A, DPF-2
⑩⑤	BrW	2	A, VS1-3
⑩⑤	GW	2	A, VS1-5
⑩⑤③	LgB	2	B, Amplitude lamp A
⑩⑤⑤	Br	3	G, VS2-1, -4
⑩⑤⑥	WL	2	G, VS2-5
⑩⑤⑦	L	2	G, VS2-3
⑩⑤⑧	BR	2	G, VS2-2
⑩⑥①	Gr	2	B, Amplitude lamp B
⑩⑥①	GW	3	Diode, HAZ-2, HPL (not in use)
⑩⑥③	R	2	G, BZ-2 (not in use)
⑩⑥④	BrR	2	FLO-6, G
⑩⑥③	WB	2	B, DPF-1
⑩①⑦	GY	2	A, Combination meter-24
⑩①⑧	Y	2	A, Combination meter-6
⑩②①	L	2	A, Combination meter-5
⑩②①	G	2	A, Combination meter-17
⑩②⑨	RB	2	A, Combination meter-12
⑩③①	RW	2	A, Combination meter-11
⑩⑥H	GY	2	C, TUR (not in use)

4-6. Air Flow Sensor Harness

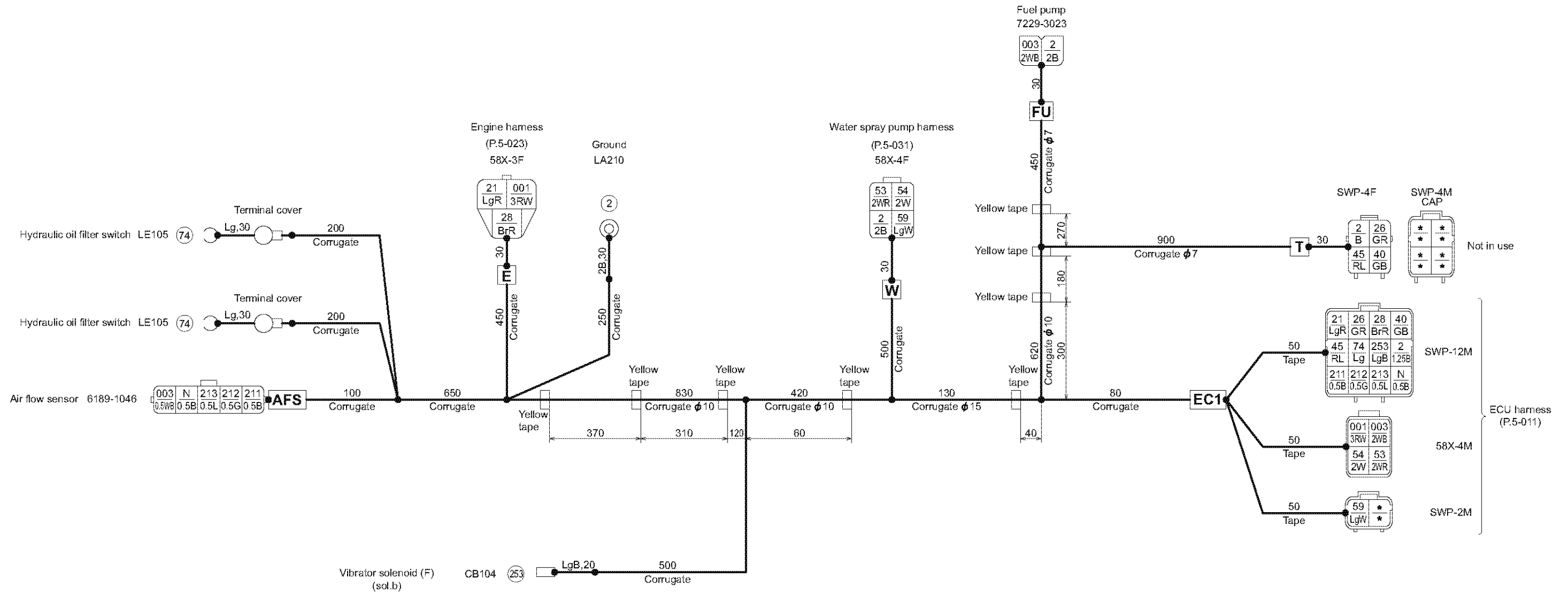

No.	SIZE, COLOR	CONTACT POINTS	CONNECTION
①	0.5B	2	AFS, EC1 (12M)
②	B, 1.25B, 2B	5	EC1 (12M), FU, W, Ground, T (not in use)
②1	LgR	2	E, EC1 (12M)
②6	GR	2	EC1 (12M), T (not in use)
②8	BrR	2	E, EC1 (12M)
④0	GB	2	EC1 (12M), T (not in use)
④5	RL	2	EC1 (12M), T (not in use)
⑤3	2WR	2	EC1 (4M), W
⑤4	2W	2	EC1 (4M), W

No.	SIZE, COLOR	CONTACT POINTS	CONNECTION
⑤9	LgW	2	EC1 (2M), W
⑦4	Lg	3	EC1 (12M), Hydraulic oil filter switch x 2
②11	0.5B	2	AFS, EC1 (12M)
②12	0.5G	2	AFS, EC1 (12M)
②13	0.5L	2	AFS, EC1 (12M)
②53	LgB	2	EC1 (12M), Vibrator solenoid (F)
①01	3RW	2	E, EC1 (4M)
①03	0.5WB, 2WB	3	AFS, EC1 (4M), FU

4-7. Battery Relay Harness

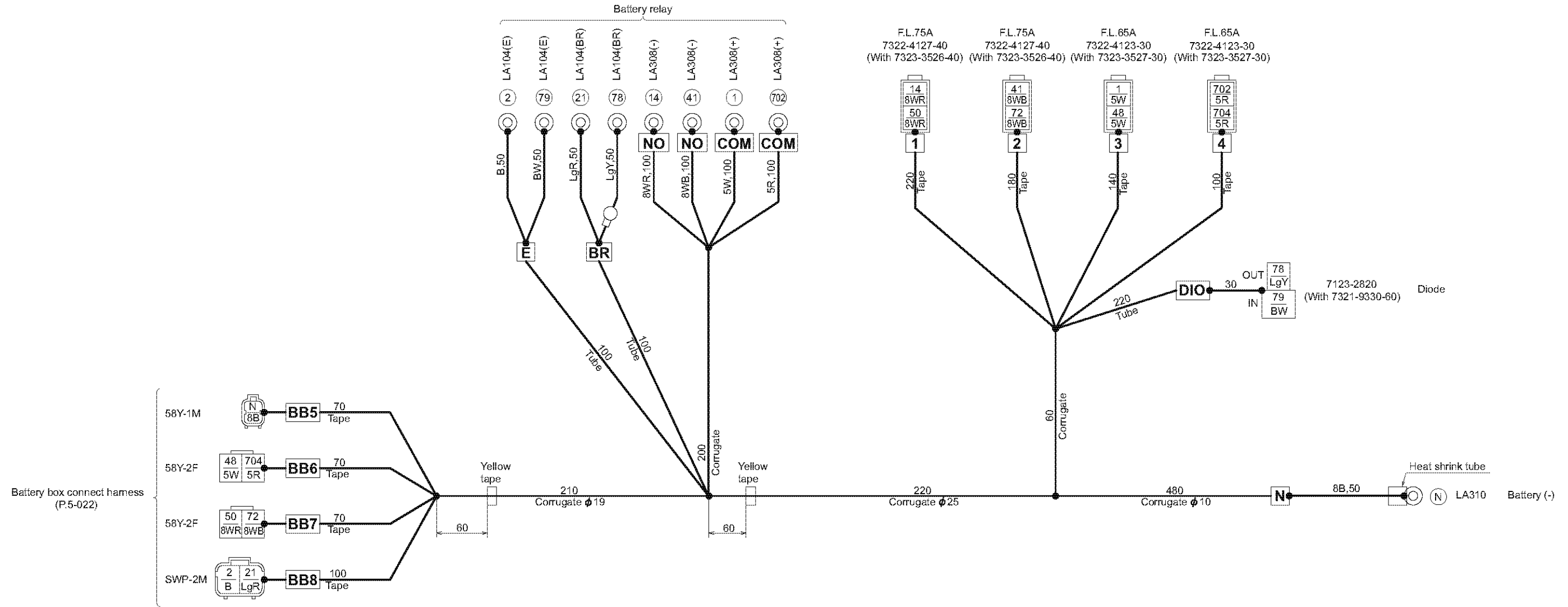

1539-09147-0-11060-0

No.	SIZE, COLOR	CONTACT POINTS	CONNECTION
(N)	8B	2	BB5, N
(1)	5W	2	COM, 3
(2)	B	2	BB8, E
(14)	8WR	2	NO, 1
(21)	LgR	2	BB8, BR
(41)	8WB	2	NO, 2
(48)	5W	2	BB6, 3

No.	SIZE, COLOR	CONTACT POINTS	CONNECTION
(50)	8WR	2	BB7, 1
(72)	8WB	2	BB7, 2
(78)	LgY	2	BR, DIO
(79)	BW	2	E, DIO
(702)	5R	2	COM, 4
(704)	5R	2	BB6, 4

4-8. Member (F) Harness

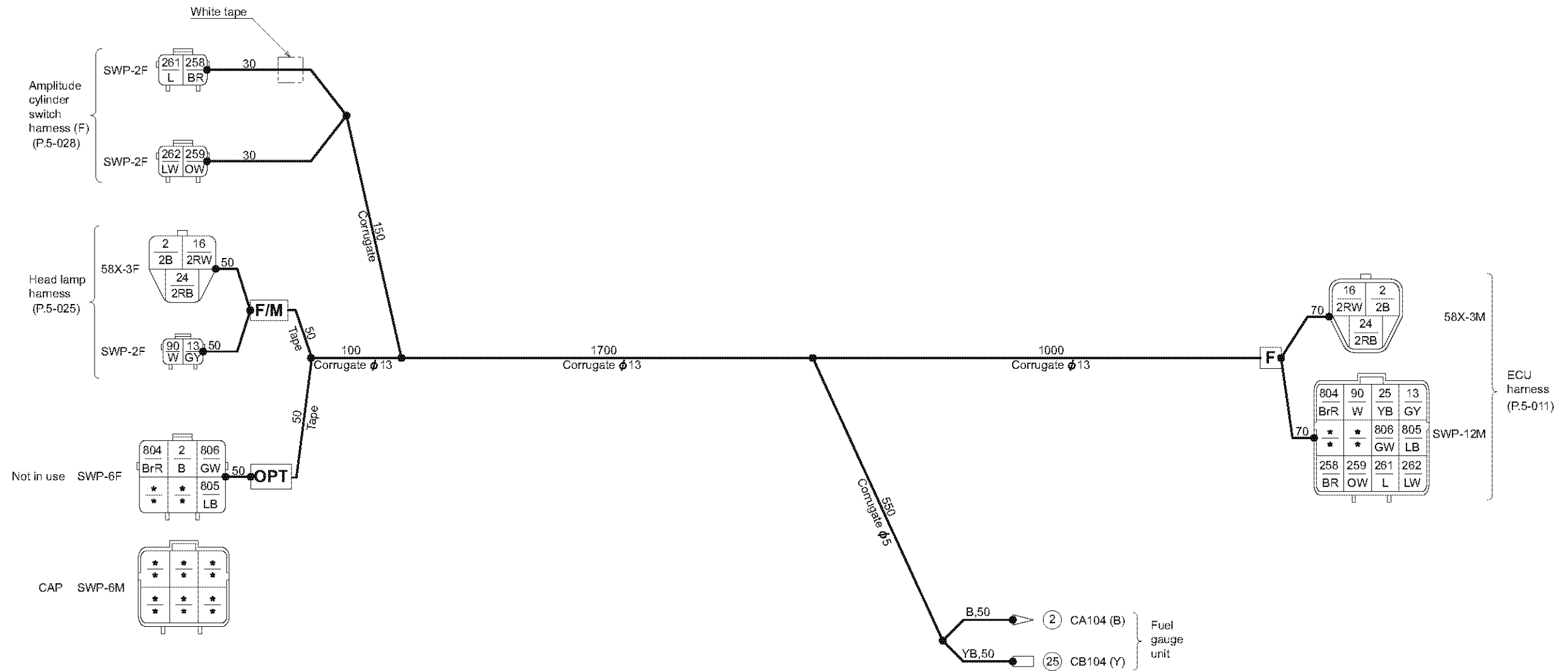

1539-09138-0-21050-0

No.	SIZE, COLOR	CONTACT POINTS	CONNECTION
②	B, 2B	4	F , F/M , OPT , Fuel gauge unit - (B)
⑬	GY	2	F , F/M
⑯	2RW	2	F , F/M
⑳	2RB	2	F , F/M
㉕	YB	2	F , Fuel gauge unit - (Y)
⑨①	W	2	F , F/M
㉖⑧	BR	2	F , Amplitude cylinder switch harness (F)

No.	SIZE, COLOR	CONTACT POINTS	CONNECTION
㉖⑨	OW	2	F , Amplitude cylinder switch harness (F)
㉖①	L	2	F , Amplitude cylinder switch harness (F)
㉖②	LW	2	F , Amplitude cylinder switch harness (F)
⑧①④	BrR	2	F , OPT
⑧①⑤	LB	2	F , OPT
⑧①⑥	GW	2	F , OPT

4-9. Member (R) Harness

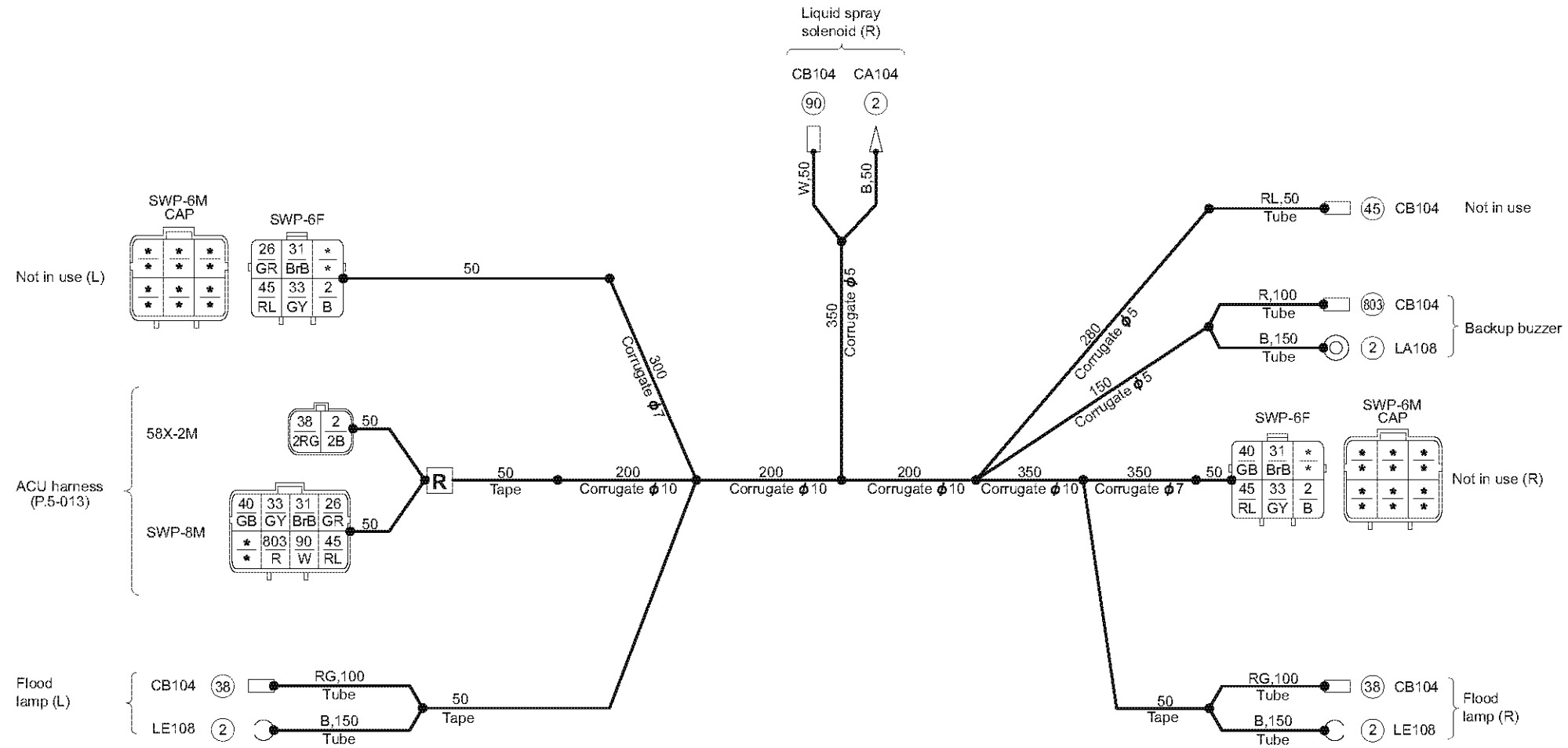

1539-09149-1-21073-A

No.	SIZE, COLOR	CONTACT POINTS	CONNECTION
②	B, 2B	7	R , Backup buzzer, Flood lamp (L), (R), Liquid spray solenoid (R), Not in use - (L), (R)
②⑥	GR	2	R , Not in use - (L)
③①	BrB	3	R , Not in use - (L), (R)
③③	GY	3	R , Not in use - (L), (R)

No.	SIZE, COLOR	CONTACT POINTS	CONNECTION
③⑧	RG, 2RG	3	R , Flood lamp (L), (R)
④①	GB	2	R , Not in use - (R)
④⑤	RL	4	R , Not in use - (L), (R), CB104
⑨①	W	2	R , Liquid spray solenoid (R)
⑧①③	R	2	R , Backup buzzer

4-10. Battery Box Connect Harness

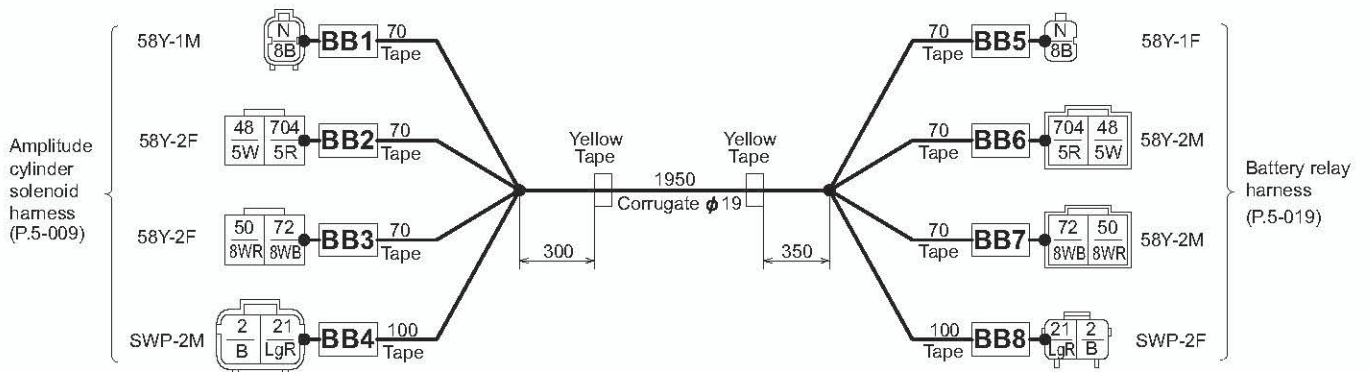

1539-09146-0-21059-0

No.	SIZE, COLOR	CONTACT POINTS	CONNECTION
(N)	8B	2	BB1, BB5
(2)	B	2	BB4, BB8
(21)	LgR	2	BB4, BB8
(48)	5W	2	BB2, BB6
(50)	8WR	2	BB3, BB7
(72)	8WB	2	BB3, BB7
(704)	5R	2	BB2, BB6

4-11. Engine Harness

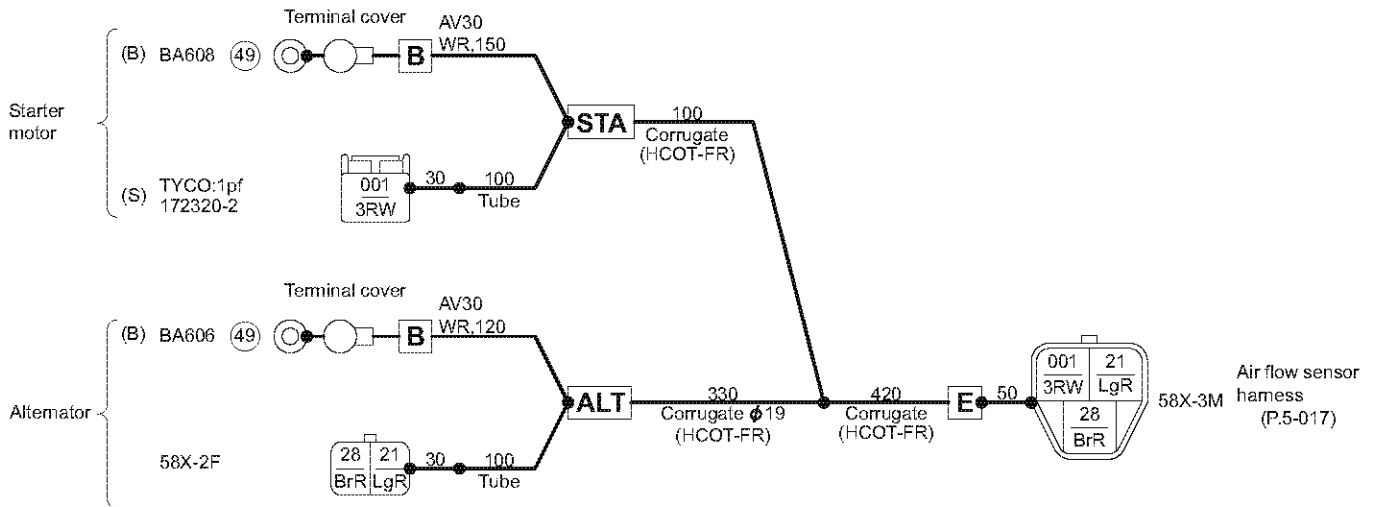

1439-09029-1-20382-B

No.	SIZE, COLOR	CONTACT POINTS	CONNECTION
②1	LgR	2	ALT, E
②8	BrR	2	ALT, E
④9	WR	2	ALT-B, STA-B
①01	3RW	2	STA, E

4-12. Starter Switch Harness

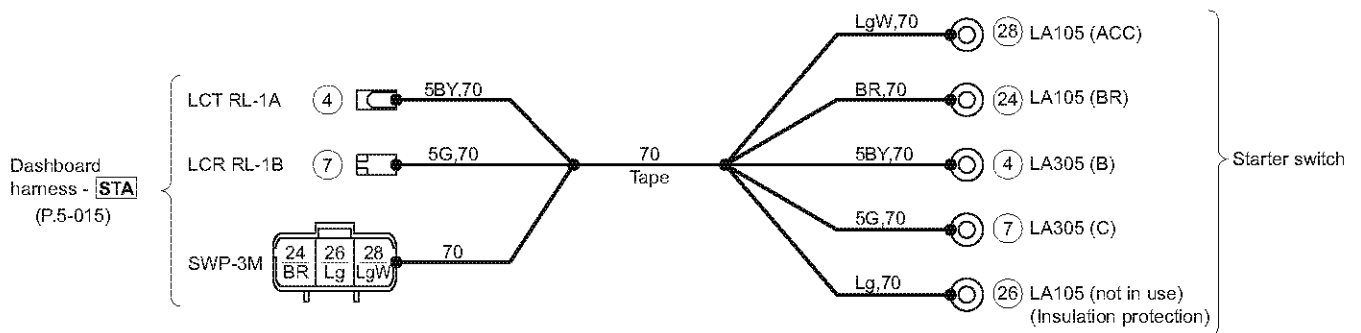

1402-09029-0-30474-B

No.	SIZE, COLOR	CONTACT POINTS	CONNECTION
④	5BY	2	Dashboard harness - STA , Starter switch-B
⑦	5G	2	Dashboard harness - STA , Starter switch-C
②④	BR	2	Dashboard harness - STA , Starter switch-BR
②⑥	Lg	2	Dashboard harness - STA , Starter switch (not in use)
②⑧	LgW	2	Dashboard harness - STA , Starter switch-ACC

4-13. Head Lamp Harness

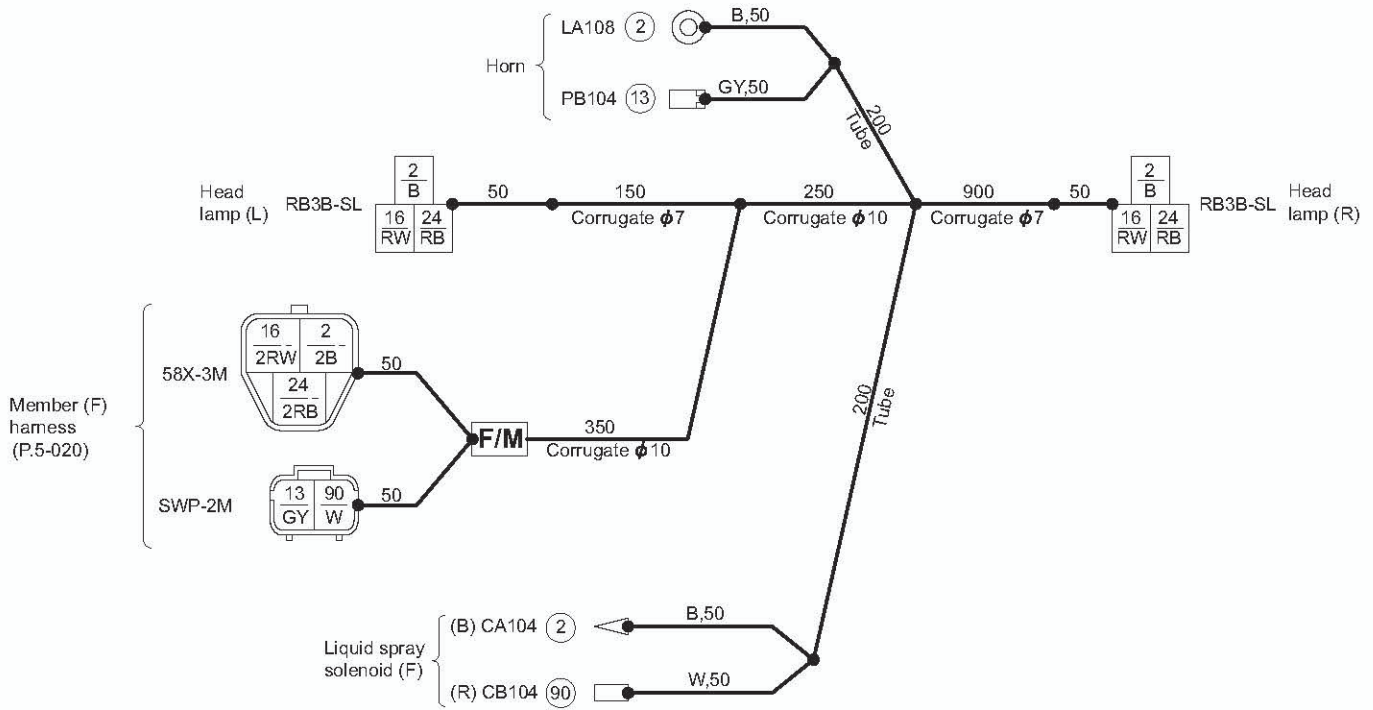

1539-09139-0-21051-0

No.	SIZE, COLOR	CONTACT POINTS	CONNECTION
②	B, 2B	5	F/M , Head lamp (L), (R), Horn, Liquid spray solenoid (F)
⑬	GY	2	F/M , Horn
⑯	RW, 2RW	3	F/M , Head lamp (L), (R)
⑳	RB, 2RB	3	F/M , Head lamp (L), (R)
⑨①	W	2	F/M , Liquid spray solenoid (F)

4-14. F-R Lever Harness

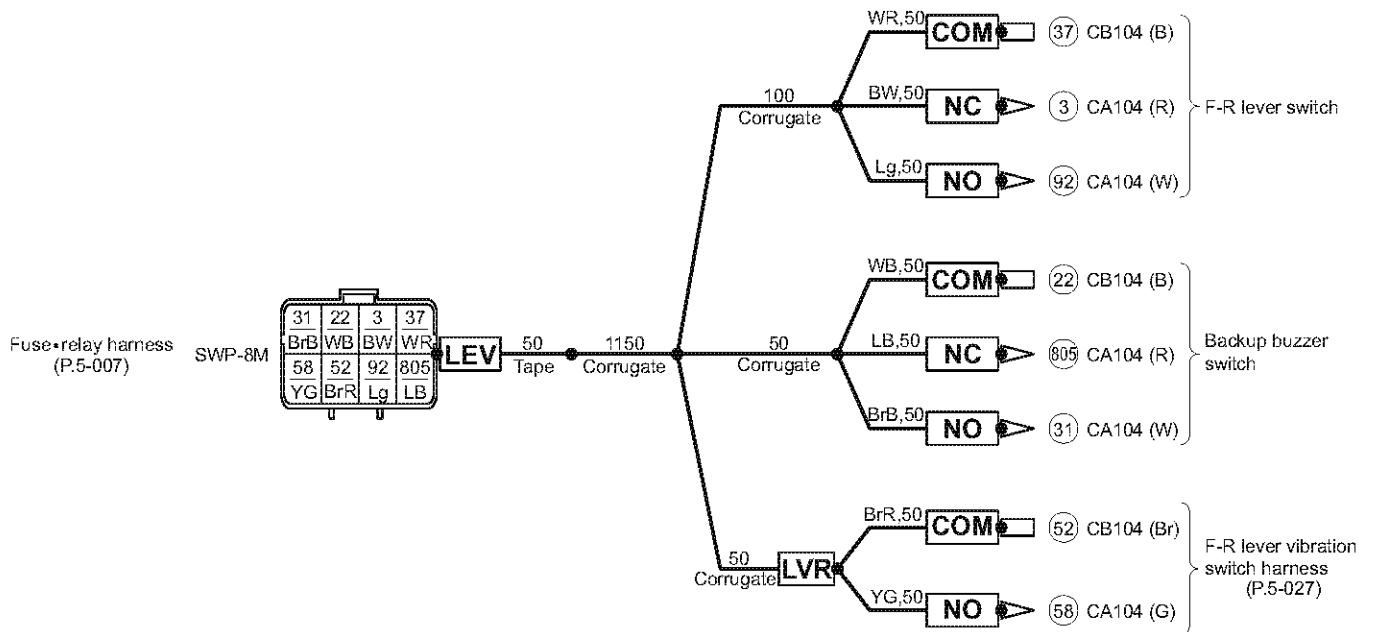

1539-09131-0-21039-A

No.	SIZE, COLOR	CONTACT POINTS	CONNECTION
③	BW	2	LEV, NC
②②	WB	2	LEV, COM
③①	BrB	2	LEV, NO
③⑦	WR	2	LEV, COM
⑤②	BrR	2	LEV, LVR, COM
⑤⑧	YG	2	LEV, LVR, NO
⑨②	Lg	2	LEV, NO
⑧①⑤	LB	2	LEV, NC

4-15. F-R Lever Vibration Switch Harness

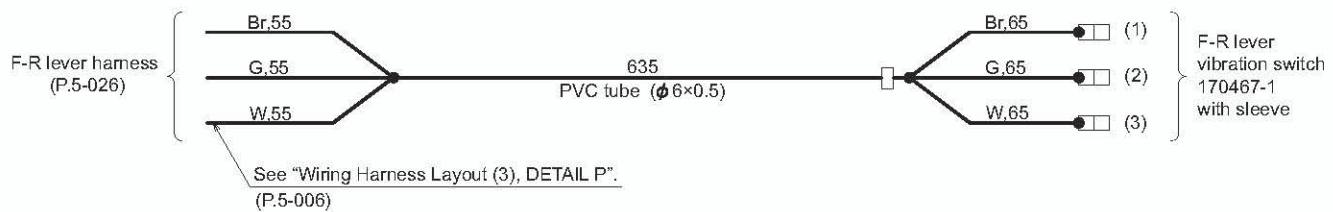

1539-12013-0-30226-0

No.	SIZE, COLOR	CONTACT POINTS	CONNECTION
–	Br	2	F-R lever harness, F-R lever vibration switch-1
–	G	2	F-R lever harness, F-R lever vibration switch-2
–	W	2	F-R lever harness, F-R lever vibration switch-3

4-16. Amplitude Cylinder Switch Harness (F)

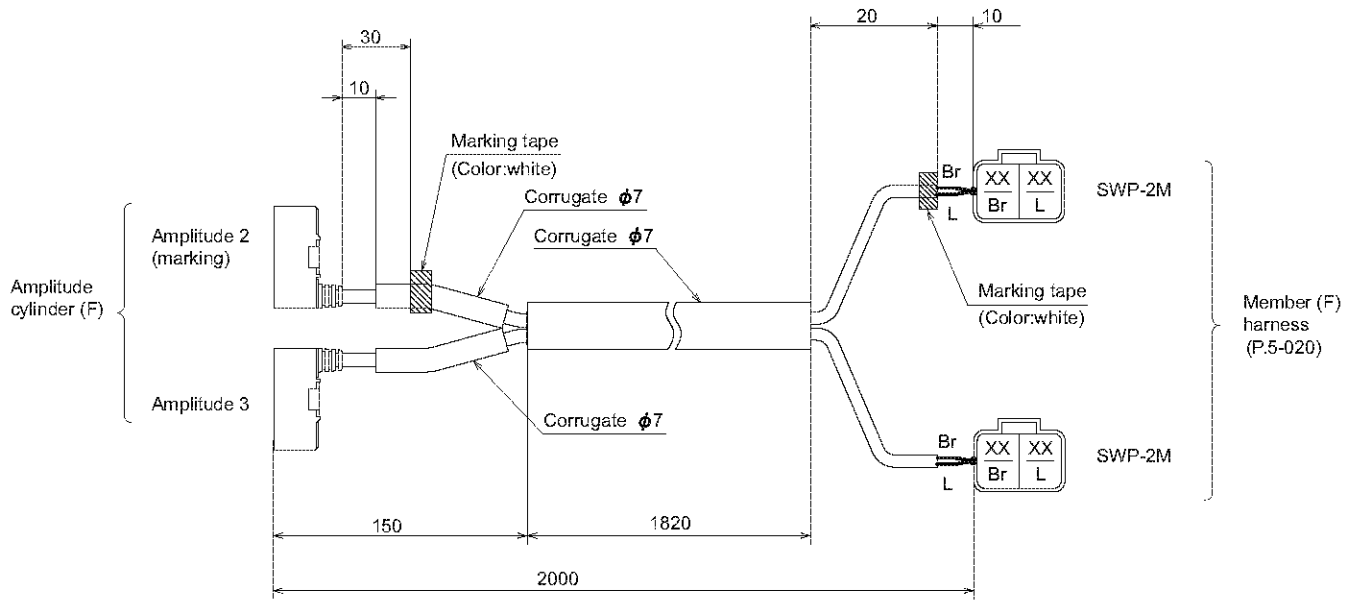

1539-09152-0-21194-A

No.	SIZE, COLOR	CONTACT POINTS	CONNECTION
XX	Br	4	Amplitude cylinder (F)-Amplitude 2, 3, Member (F) harness × 2
	L	4	Amplitude cylinder (F)-Amplitude 2, 3, Member (F) harness × 2

4-17. Amplitude Cylinder Switch Harness (R, L)

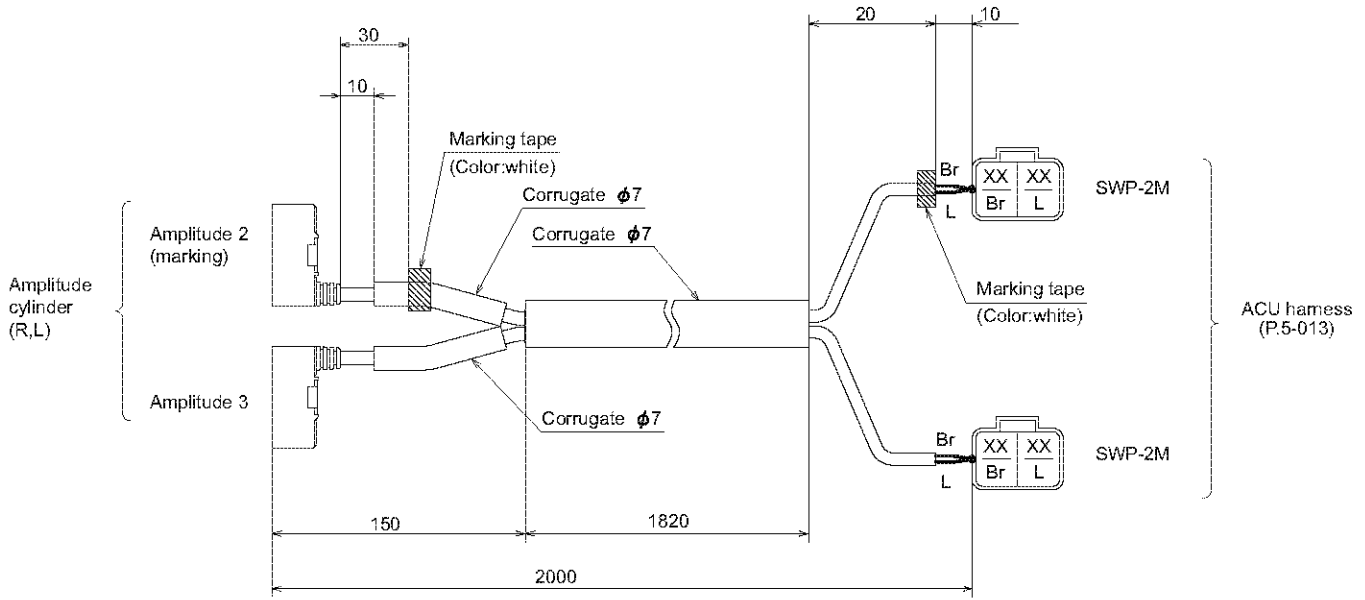

1539-09152-0-21194-A

No.	SIZE, COLOR	CONTACT POINTS	CONNECTION
XX	Br	4	Amplitude cylinder (R,L)-Amplitude 2, 3, ACU harness × 2
	L	4	Amplitude cylinder (R,L)-Amplitude 2, 3, ACU harness × 2

4-18. Amplitude Cylinder Switch Harness (R, R)

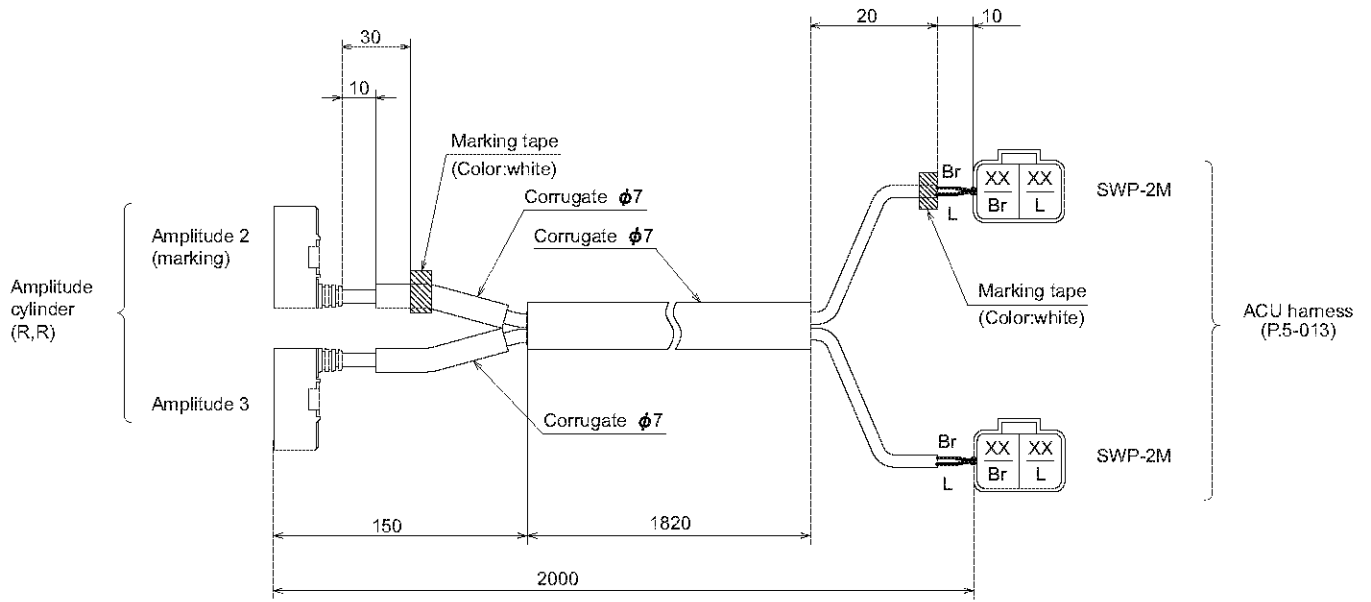

1539-09152-0-21194-A

No.	SIZE, COLOR	CONTACT POINTS	CONNECTION
⊗	Br	4	Amplitude cylinder (R,R)-Amplitude 2, 3, ACU harness × 2
	L	4	Amplitude cylinder (R,R)-Amplitude 2, 3, ACU harness × 2

4-19. Water Spray Pump Harness

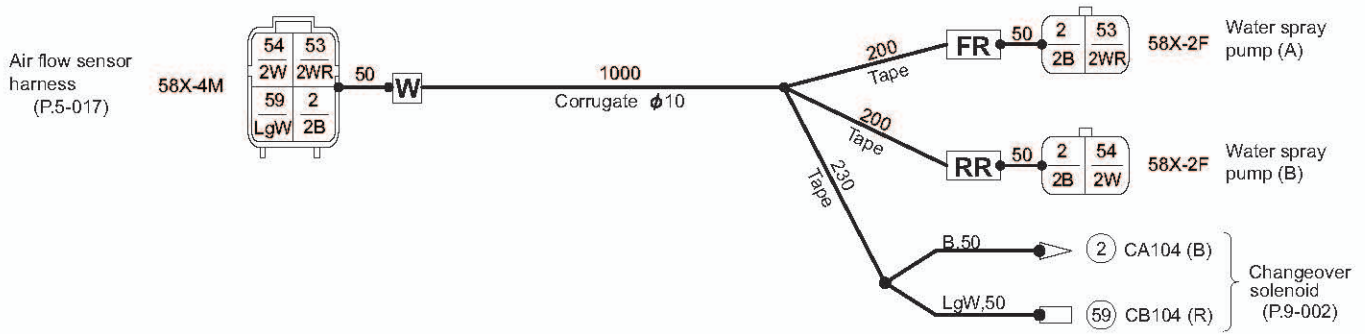

1539-09168-0-31318-0

No.	SIZE, COLOR	CONTACT POINTS	CONNECTION
②	2B	4	W, FR, RR, Changeover solenoid - (B)
⑤③	2WR	2	W, FR
⑤④	2W	2	W, RR
⑤⑨	LgW	2	W, Changeover solenoid - (R)

4-20. Cord

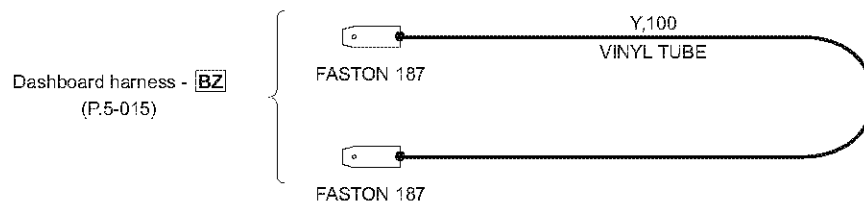

1559-09087-0-41208-0

No.	SIZE, COLOR	CONTACT POINTS	CONNECTION
-	Y	2	Dashboard harness BZ × 2

4-21. Ground Cord 1

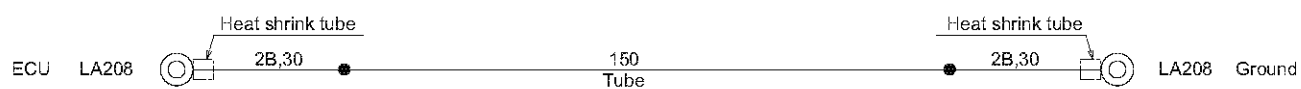

1439-09021-0-40124-0

No.	SIZE, COLOR	CONTACT POINTS	CONNECTION
—	2B	2	ECU, Ground

4-22. Ground Cord 2

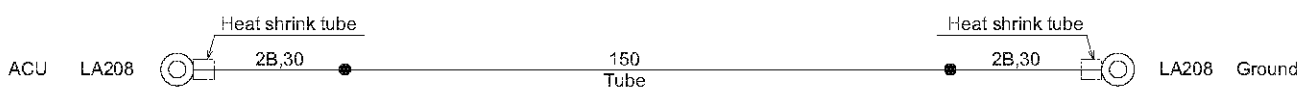

1439-09021-0-40124-0

No.	SIZE, COLOR	CONTACT POINTS	CONNECTION
—	2B	2	ACU, Ground

4-23. Ground Cord 3

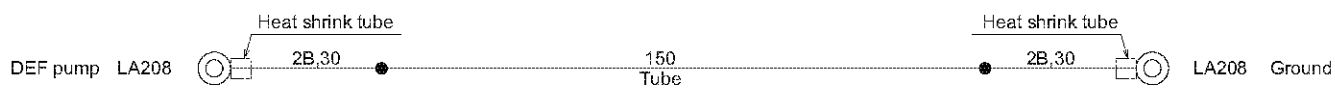

1439-09021-0-40124-0

No.	SIZE, COLOR	CONTACT POINTS	CONNECTION
-	2B	2	DPF punp, Ground

5. ELECTRICAL COMPONENT SPECIFICATIONS

5-1. Fuse Box 1

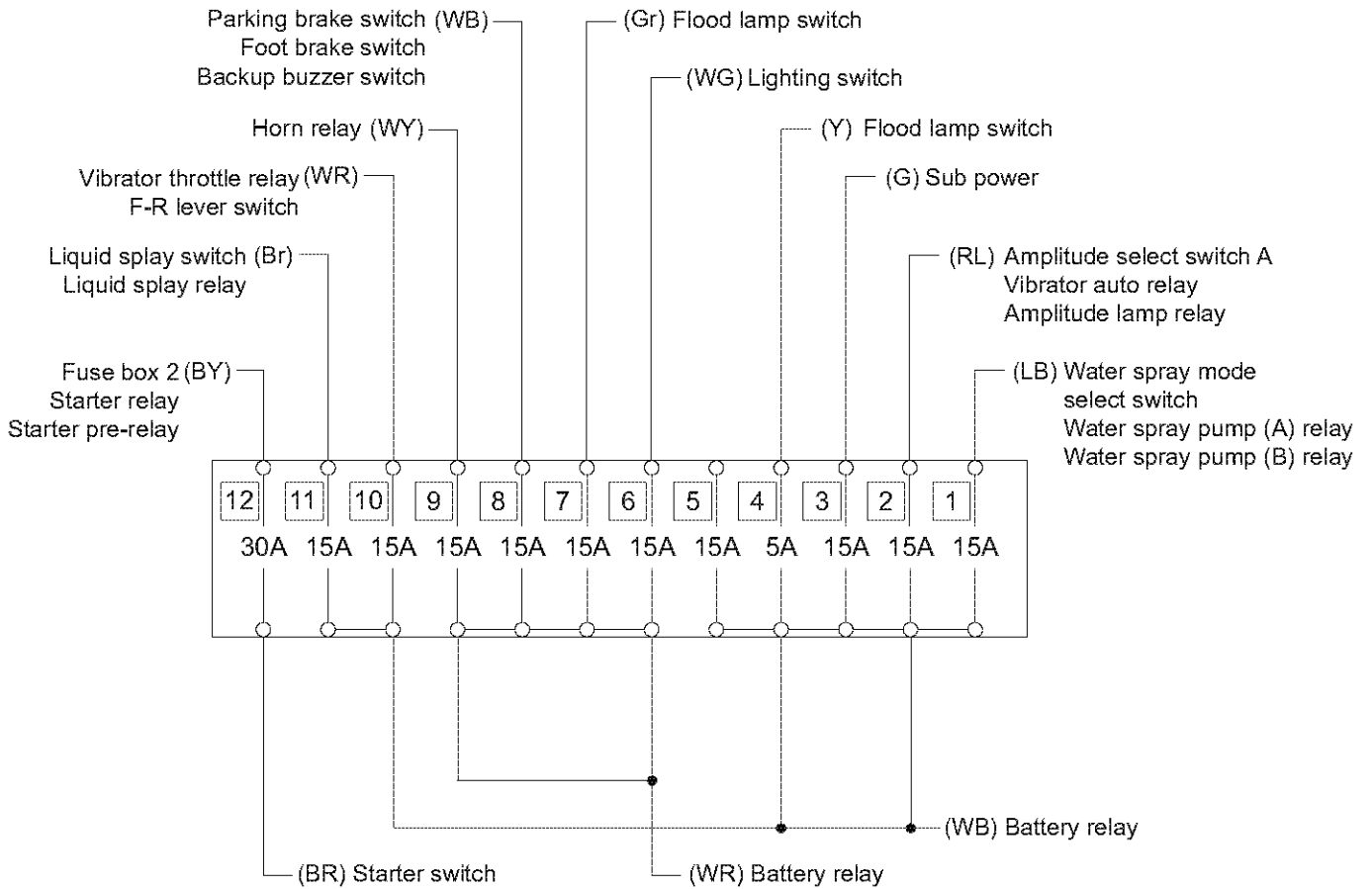

· For the relay box, refer to "4-1. Fuse - Relay Harness" (P.5-007).
 · For the wire color code, refer to "Wire color code chart" (P.5-002).

5-2. Fuse Box 2

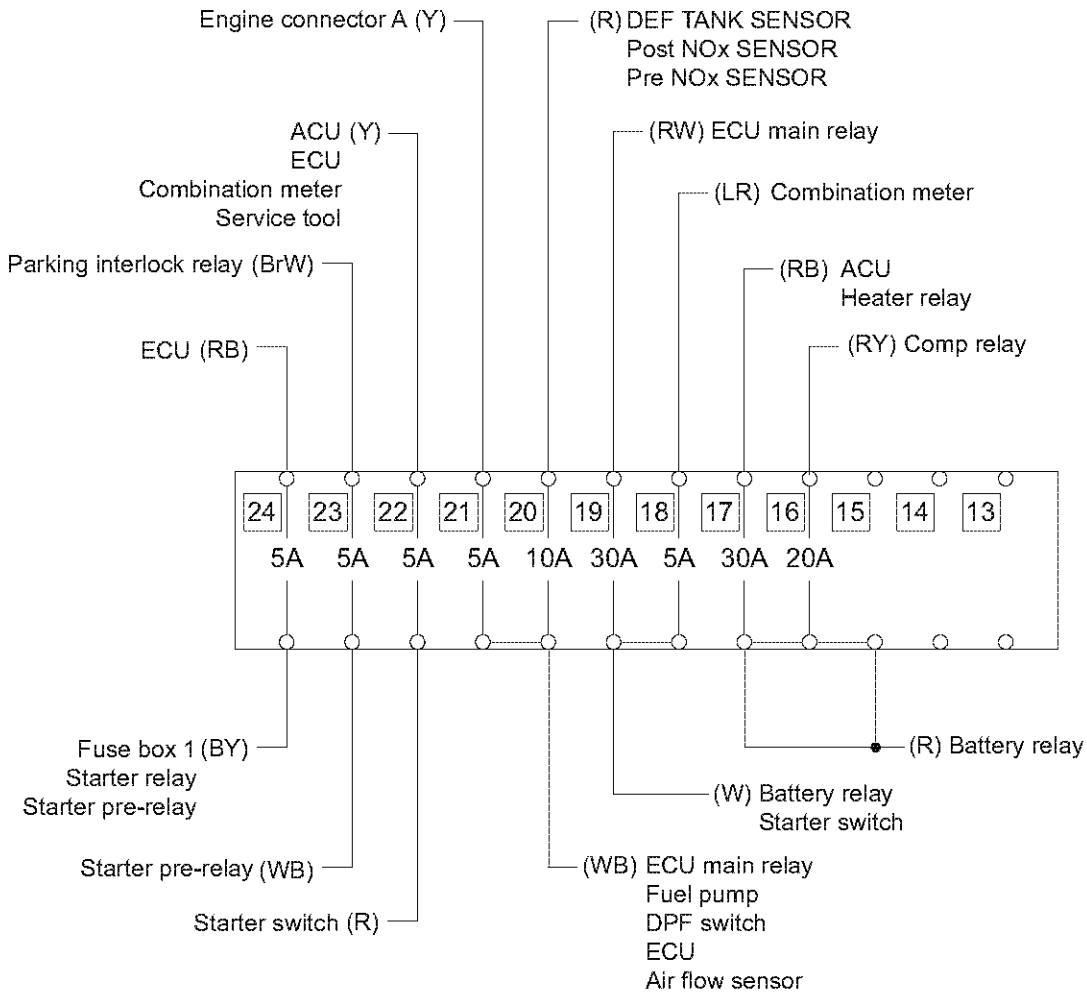

- For the relay box, refer to "4-1. Fuse · Relay Harness" (P.5-007).
- For the wire color code, refer to "Wire color code chart" (P.5-002).

GW754-05002

5-3. Combination Meter

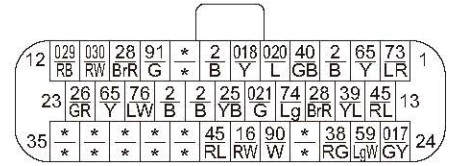
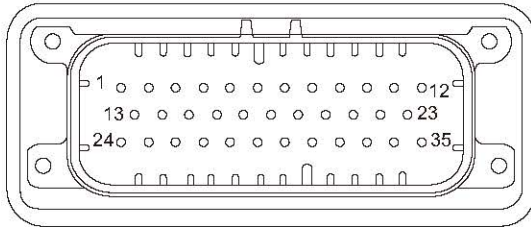
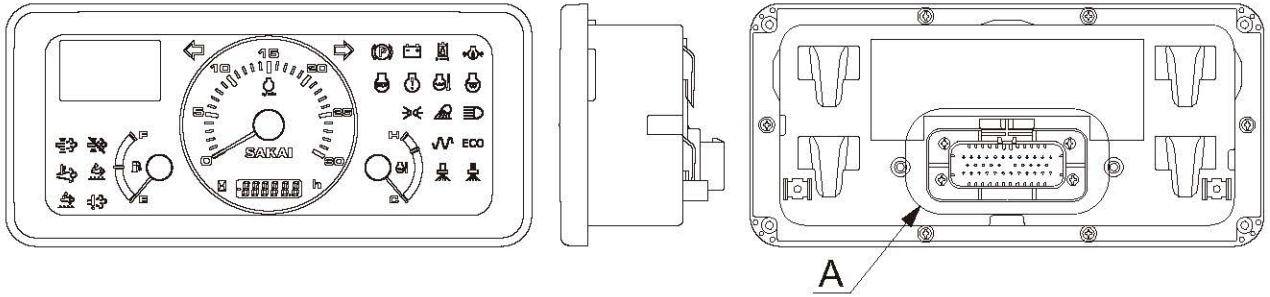

Harness side

DETAIL A

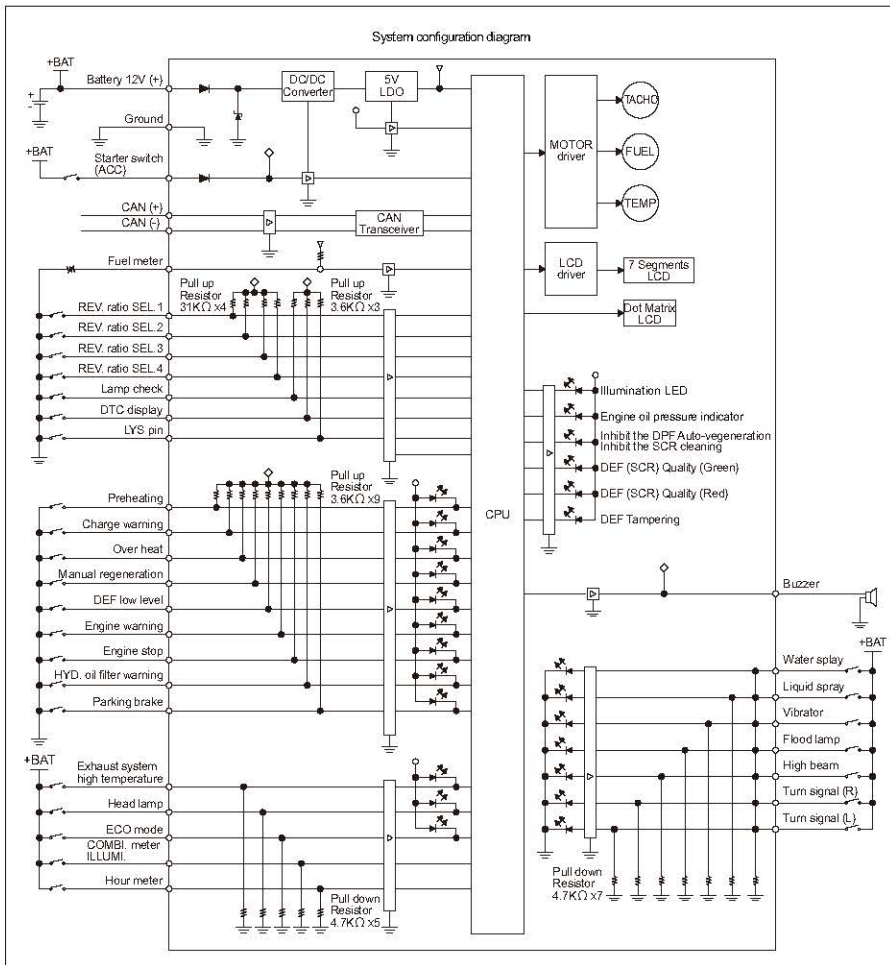

PIN	DESCRIPTION	NO.
1	BATTERY 12V (+)	(73)
2	STARTER SWITCH (ACC)	(65)
3	GROUND	(2)
4	TURN SIGNAL (R)	(40)
5	ENGINE STOP	(020)
6	OVER HEAT	(018)
7	REV. RATIO SEL. 1	(2)
8	REV. RATIO SEL. 3	
9	BUZZER	(91)
10	LAMP CHECK	(28)
11	CAN(+)	(030)
12	CAN(-)	(029)
13	HEAD LAMP (SIDE MARKER)	(45)
14	PARKING BRAKE	(39)
15	CHARGE WARNING	(28)
16	HYD. OIL FILTER WARNING	(74)
17	ENGINE WARNING	(021)
18	FUEL METER	(25)
19	REV. RATIO SEL. 2	(2)
20	REV. RATIO SEL. 4	(2)
21	DTC DISPLAY	(76)
22	HOUR METER	(65)
23	TURN SIGNAL (L)	(26)
24	PREHEATING	(017)
25	WATER SPRAY	(59)
26	FLOOD LAMP	(38)
27	VIBRATOR	
28	LIQUID SPRAY	(90)
29	HIGH BEAM	(16)
30	COMBI. METER ILLUMI.	(45)
31	EXHAUST SYSTEM HIGH TEMPERATURE	
32	DEF LOW LEVEL	
33	MANUAL REGENERATION	
34	LYS PIN	
35	ECO MODE	

WHEEL AND VIBRATOR SYSTEM

1. PRECAUTIONS FOR DISASSEMBLY AND REASSEMBLY

- When removing, installing, disassembling or reassembling the unit, observe the general precautions described below.
- 1) Precautions for removal work
 - Coolant that contains antifreeze should be treated as a chemical, and must not be drained carelessly on the ground.
 - To prevent dust from getting into disconnected hoses and tubes, cover them with a plug or similar means.
 - When draining oil, use a receptacle with sufficient capacity to receive it.
 - Before proceeding with the work, look for matchmarks that show the installation location. For reassembly, place matchmarks in the required locations to prevent errors. Then remove.
 - When disconnecting wiring connectors, hold the connector components so that unreasonable force is not applied to the wires.
 - Label wires and hoses to ensure correct installation location.
 - Confirm the number and thickness of shims prior to storage.
 - When lifting parts, use lifting equipment of sufficient capacity.
 - When separating parts by using pull bolts, tighten the bolts alternately.
 - Before removing a unit, clean its surrounding area. Then after removal, cover it to prevent dust and other substances from getting in.
 - Before removing piping for hydraulic oil or coolant, or removing related parts, satisfactorily release internal pressure.
 - 2) Precautions for installation work
 - Tighten bolts and nuts (sleeve nuts) to the specified torque (screw tightening torque table).
 - When installing hoses, do not twist them or allow them to interfere with other parts.
 - Replace gaskets, O-rings, split pins, and lock plates with new parts.
 - Properly bend split pins and lock plates.
 - When applying an adhesive, first clean and remove oil/grease from the surfaces properly. Then apply two or three drops to the threaded areas.
 - When applying a liquid gasket, first clean and remove oil/grease from the application surface properly, and confirm that the surface is free of dust and damage. Then apply the product evenly.
 - Clean parts well. Repair scratches, dents, burrs, rust, etc.
 - Apply grease to rotating and sliding components.
 - Apply gear oil to the surfaces of press-fit parts.
 - After installing snap rings, confirm that they are properly seated in the grooves.
 - Connect wiring connectors securely after cleaning off adhering oil, dust and water.
 - Use lifting bolts that are not fatigued or deformed. Screw them in fully.
 - When tightening a split flange, tighten screws alternately to prevent uneven tightening.
 - Before installing hydraulic parts, confirm that they are free of damage and dust, etc.

3) Precautions when work is completed

- If coolant has been drained, securely retighten the drain valve and fill with coolant (mixing in long-life coolant) to the specified level. Start the engine and allow the coolant to circulate through the piping. Then add coolant again to the specified level.
- If hydraulic equipment has been removed and reinstalled, fill with hydraulic oil to the specified level. Start the engine and allow the oil to circulate through the piping. Then add oil again to the specified level.

2. FRONT WHEEL

2-1. Removal and Installation of Front Wheel ASSY

2-1-1. Removal of front wheel ASSY

- 1) Securing machine
 - Hold rear wheel with chocks.
 - Lock front and rear frames with steering lock bar (1).

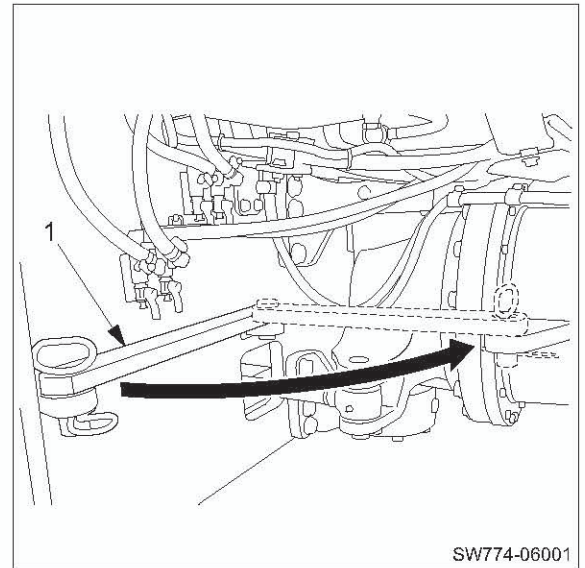

⚠ WARNING

The hydraulic oil in the machine is hot and compressed immediately after the machine is stopped. Disconnecting the hydraulic hoses in this condition can cause burns. Wait for the hydraulic oil to cool down before starting the work.

- 2) Disconnecting piping
 - 2-1) Disconnecting vibrator motor piping
 - Remove bolts (5).
 - Remove protector (6).
 - Remove protector on other side in same way.
 - Remove hose clamp (7).
 - Disconnect hydraulic hoses (2), (3) and (4) from vibrator motor.

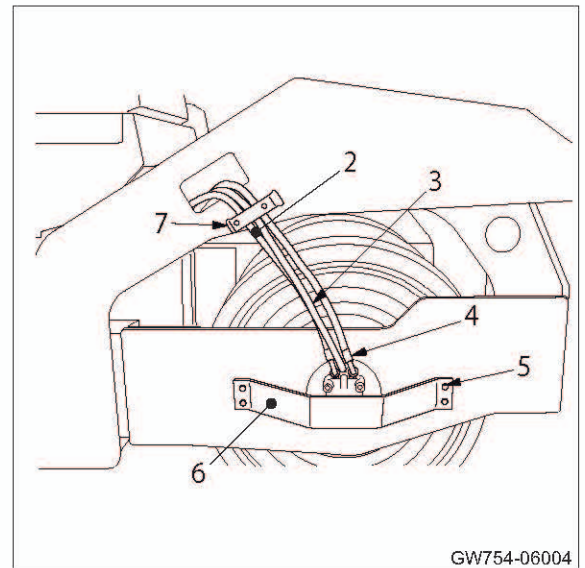

(NOTICE)

- **Plug both ends of the disconnected hoses or implement other actions to prevent entry of foreign matter.**

2-2) Disconnecting amplitude cylinder piping and wiring

- Remove switch harness (9) from amplitude cylinder (10).
- Disconnect hydraulic hoses (8) and (11) from amplitude cylinder.

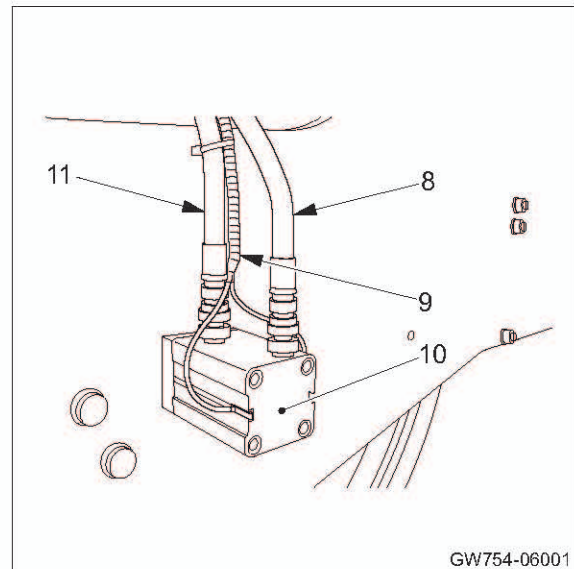

2-3) Disconnecting propulsion motor piping

- Remove hose clamp (16).
- Disconnect hydraulic hoses (12), (13), (14) and (15) from propulsion motor.

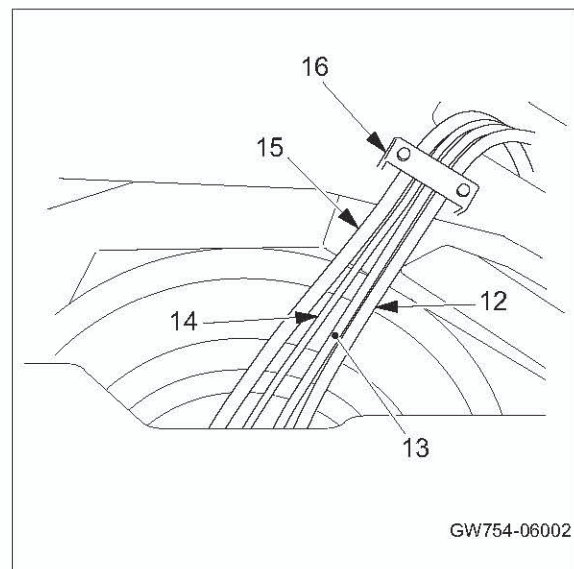

⚠ DANGER

- When lifting the machine body, use an appropriate hoist of sufficient strength. Confirm that the surrounding area is safe, and work in a natural, unstrained posture.
- Also, to firmly secure the machine body, use a support stand of sufficient strength.
- The vehicle must be parked on level place and chock the rear wheel with blocks.

3) Supporting frame

- Lift frame with a crane.
- Place support stands under frame when wheel is slightly off ground to support machine body.



Front axle weight : 3,680 kg (8,115 lbs.)

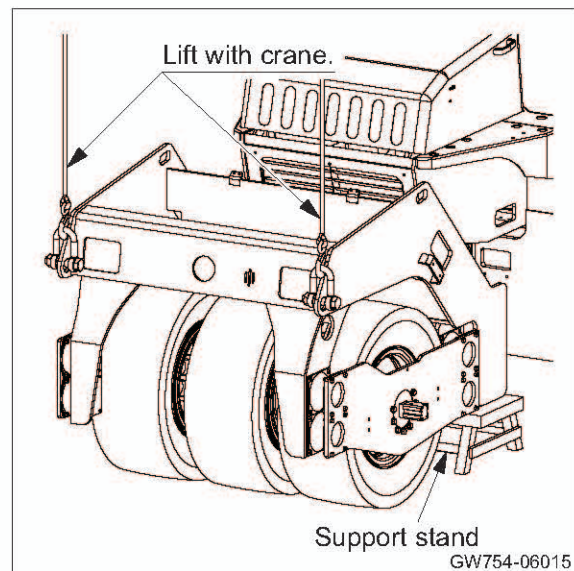

4) Removal of front wheel ASSY

4-1) Lift front wheel ASSY (17) with a crane.

- Remove nuts (19) and bolts (18).
- Remove nuts and bolts on other side in same way.
- Lift frame with a crane to secure space enough to pull out front wheel ASSY sideward.

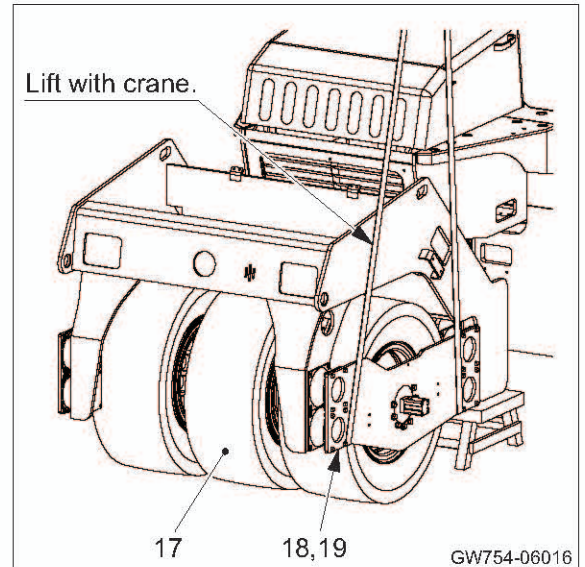

⚠ WARNING

When using a forklift, confirm the safety in the working area, especially surely check the safety in the back area when moving backward.

4-2) Using a forklift, pull out front wheel ASSY (17) sideward to remove it.

 (17) Front wheel ASSY : 1,090 kg (2,403 lbs.)

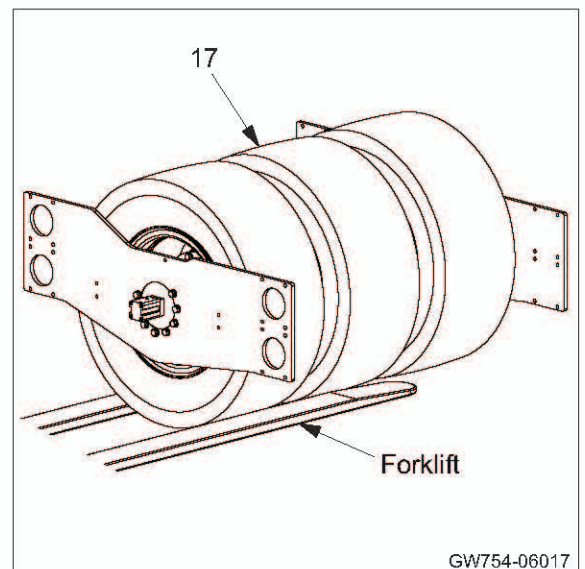

5) Hold front wheel ASSY (17) with chocks.

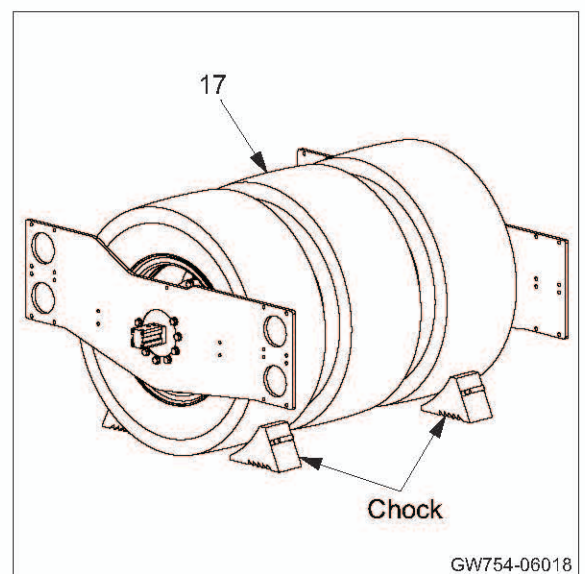

2-1-2. Installation of front wheel ASSY

- 1) Install front wheel ASSY in reverse order in which it was removed.
 - Tightening torque for nuts where particular care is required when installing front wheel ASSY.



(19) Nuts M12 : 108 N·m (80 lbf·ft)

(NOTICE)

- Install switch harnesses (9) to amplitude cylinder (10) at positions shown right.

★ Specified dimension a: 30 mm (1.2 in.)

b: 22 mm (0.9 in.)

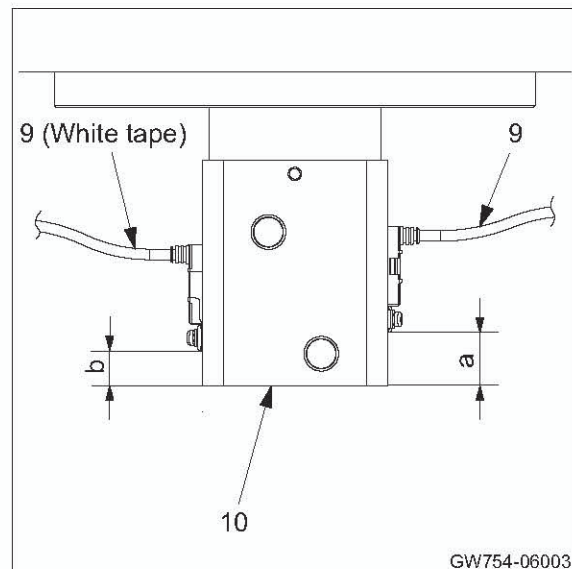

- 2) Upon installing front wheel ASSY, pay particular attention to items mentioned below.
 - Fill hydraulic oil tank to specified level to make up for any oil leakage.
 - Start engine and circulate oil through piping. Then check oil level again, ensuring that oil is at specified level.

(NOTICE)

- If the engine is run at high speed or the cylinder is operated to full stroke when the engine is started for the first time after the work is completed, the piston packing or other items may be damaged by air entering into the cylinder.

2-2. Front Wheel ASSY

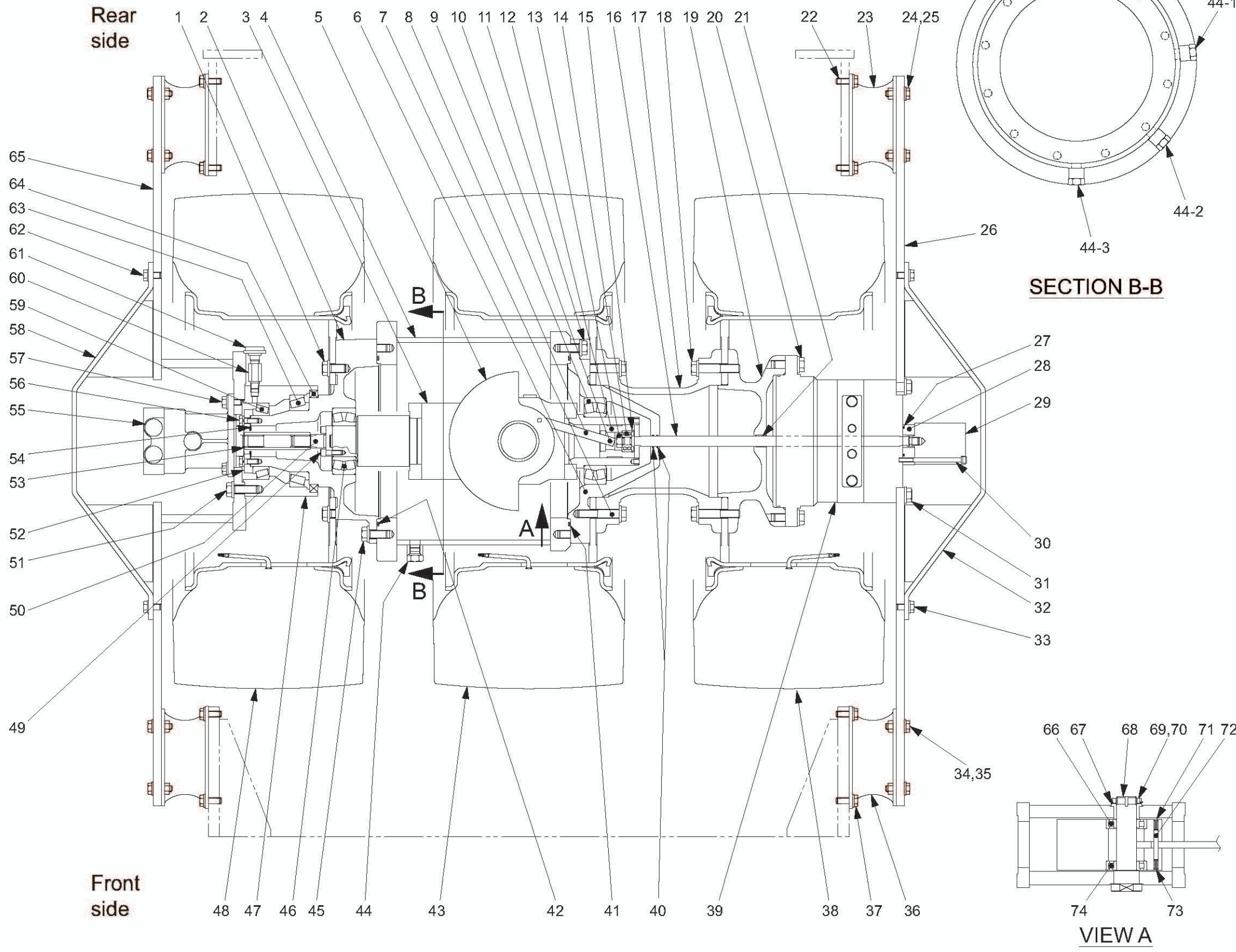

- | | |
|-------------------------|---------------------|
| (1) Bolt : M16×35 | (50) Shaft |
| (2) Axle | (51) Bolt : M16×50 |
| (3) Shaft | (52) Cover |
| (4) Case | (53) Sleeve |
| (5) Weight | (54) Shim |
| (6) Axle | (55) Vibrator motor |
| (7) Bolt : M16×85 | (56) Bolt : M10×30 |
| (8) Arm | (57) Bolt : M12×30 |
| (9) Vibrator bearing | (58) Protector |
| (10) Pin | (59) Roller bearing |
| (11) Bolt : M16×45 | (60) Adapter |
| (12) Guide | (61) Breather |
| (13) Nut : M14 | (62) Bolt : M12×25 |
| (14) Bearing | (63) Roller bearing |
| (15) Retaining ring | (64) Oil seal |
| (16) Rod | (65) Plate |
| (17) Adapter | (66) Roller bearing |
| (18) Bolt : M16×85 | (67) Collar |
| (19) Flange | (68) Shaft |
| (20) Bolt : M16×50 | (69) Bearing washer |
| (21) Bush | (70) Bearing nut |
| (22) Bolt : M12×40 | (71) Spring pin |
| (23) Damper | (72) Pin |
| (24) Bolt : M12×40 | (73) Spring pin |
| (25) Nut : M12 | (74) Roller bearing |
| (26) Plate | |
| (27) O-ring | |
| (28) Adapter | |
| (29) Amplitude cylinder | |
| (30) Bolt : M 8×125 | |
| (31) Bolt : M16×110 | |
| (32) Protector | |
| (33) Bolt : M12× 25 | |
| (34) Bolt : M12× 40 | |
| (35) Nut : M12 | |
| (36) Damper | |
| (37) Bolt : M12× 25 | |
| (38) Tire ASSY | |
| (39) Propulsion motor | |
| (40) O-ring | |
| (41) O-ring | |
| (42) O-ring | |
| (43) Tire ASSY | |
| (44) Plug | |
| (45) Bolt : M16×40 | |
| (46) Vibrator bearing | |
| (47) Housing | |
| (48) Tire ASSY | |
| (49) Bolt | |
- : 3/8-16UNC × 1 1/4 in.

2-3. Disassembly and Reassembly of Front Wheel

- Lead line numbers shown in the illustrations for the following front wheel disassembly and reassembly procedures are constant with part numbers of front wheel ASSY shown on page 6-007.

2-3-1. Disassembly of front wheel

- 1) Remove plug (44-1) and drain plug (44-3).
 - Drain gear oil.
 - Quantity of gear oil : 3.2 L (0.85 gal.)
 - Install plug (44-1) and drain plug (44-3) to case (4).

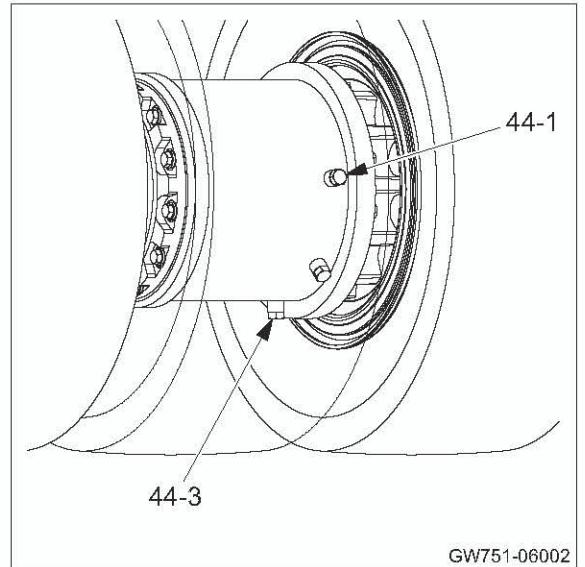

- 2) Remove bolts (30).
 - Pull out cylinder rod and rod (16).
 - Using wrenches, remove cylinder rod from rod .
 - Remove amplitude cylinder (29) and adapter (28).

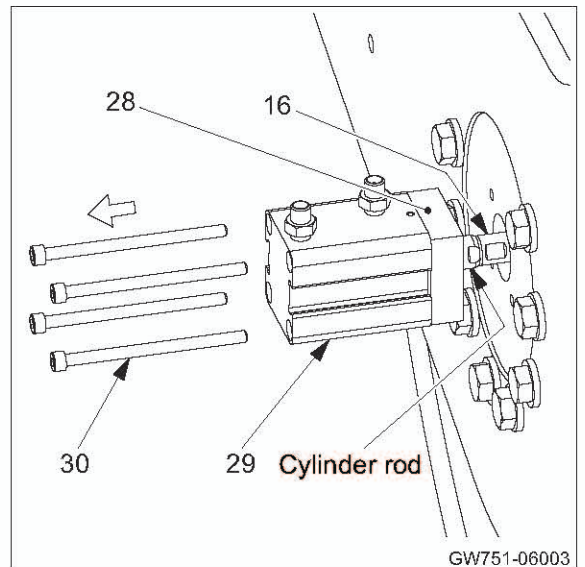

⚠ WARNING

When lifting the plate, use an appropriate hoist of sufficient strength. Confirm that the surrounding area is safe, and work in a natural, unstrained posture.

- 3) Lift plate (26).
 - Remove bolts (31).
 - Remove plate.

 (26) Plate : 70 kg (154 lbs.)

(NOTICE)

- Take care not to damage threaded portion of the rod (16) when removing parts.

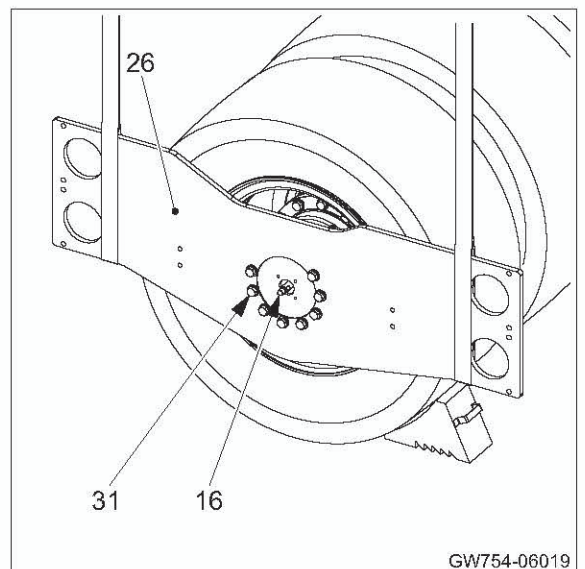

- 4) Remove bolts (57).

 - Remove vibrator motor (55).

 (55) Vibrator motor : 15 kg (33 lbs.)

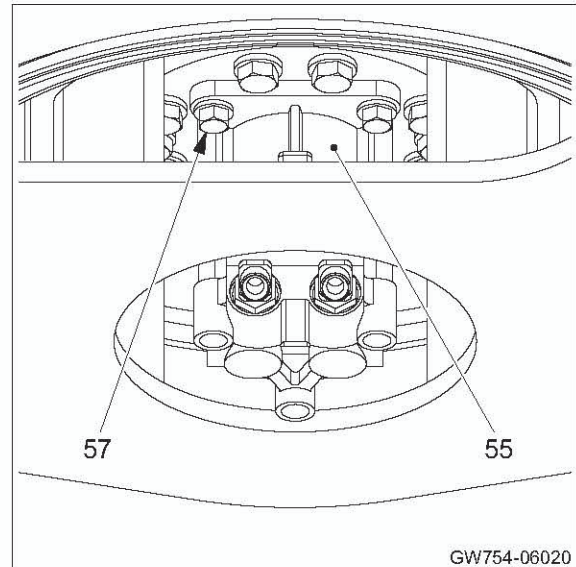

- 5) Remove sleeve (53).

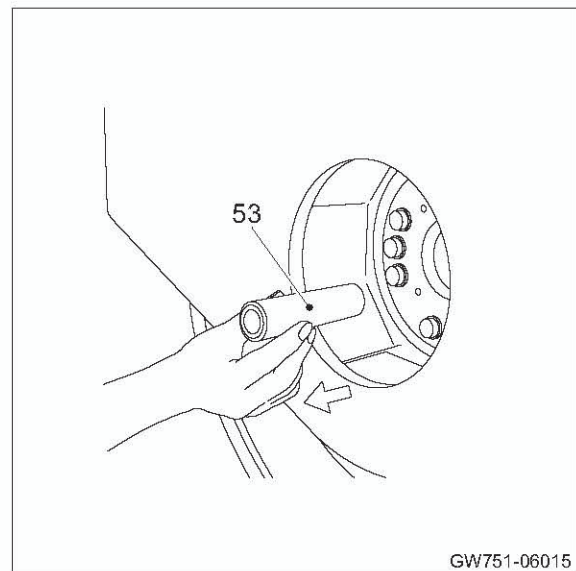

- 6) Lift plate (65).

 - Remove bolts (51).
 - Remove plate.

 (65) Plate : 100 kg (220 lbs.)

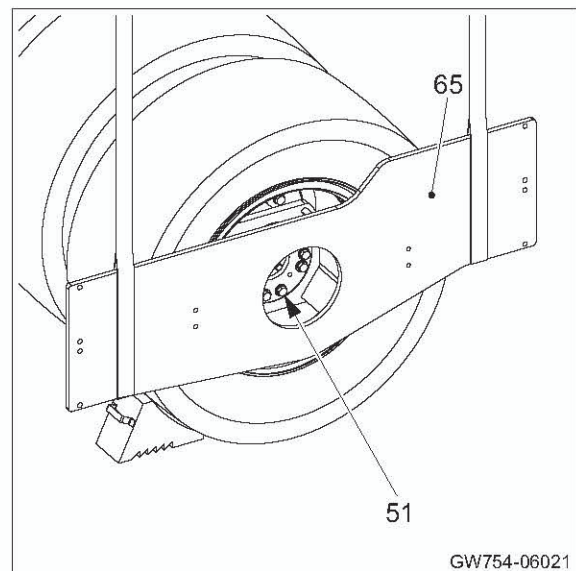

WARNING

Carry out the work in an unstrained posture using a work stool or the like.

- 7) Stand wheel SUBASSY with propulsion motor (39) side facing up.

 Wheel SUBASSY : 895 kg (1,973 lbs.)

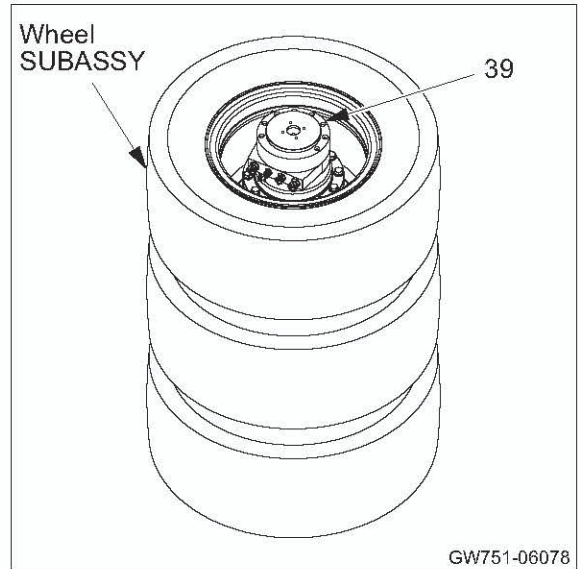

WARNING

When installing lifting bolts, screw in the threads fully before using.

- 8) Install lifting bolts (M16) to propulsion motor (39).
 - Remove bolts (20).

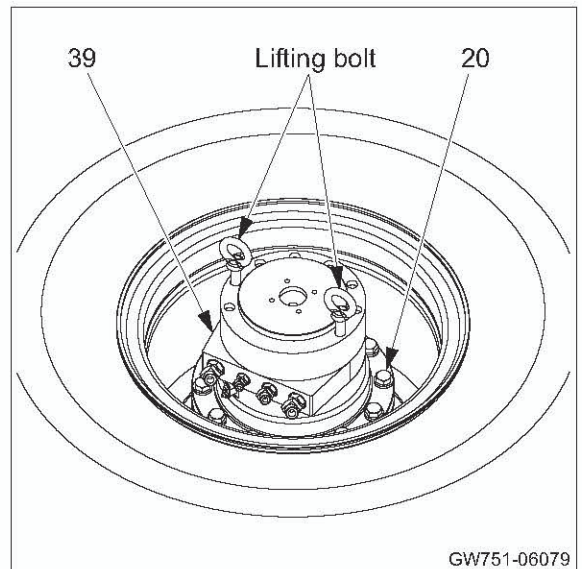

- 9) Remove propulsion motor (39).

 (39) Propulsion motor : 80 kg (176 lbs.)

(NOTICE)

- Take care not to damage threaded portion of the rod (16) when removing parts.

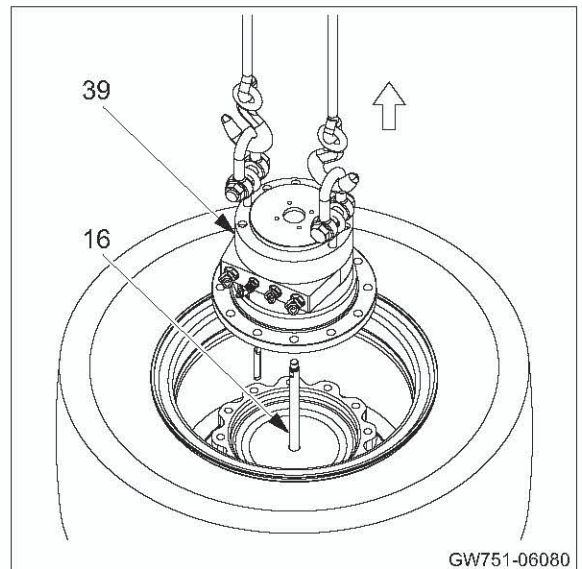

10) Remove bolts (7).

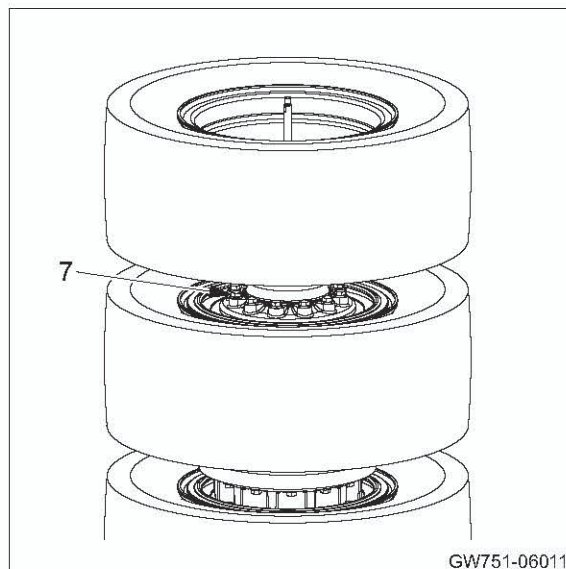

11) Install lifting bolts (M16) to wheel SUBASSY.

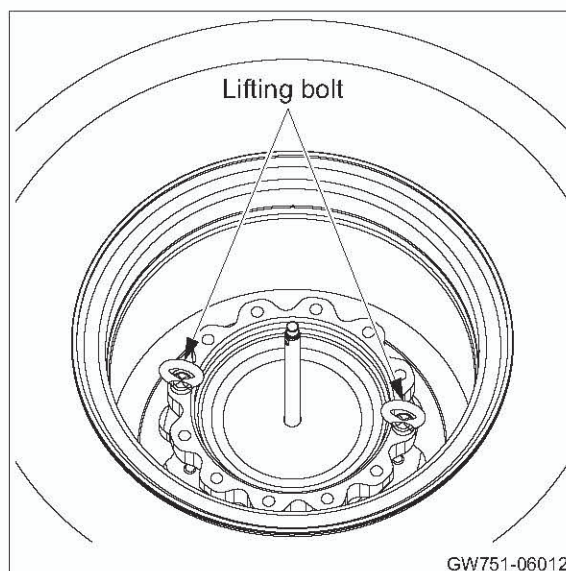

12) Remove wheel SUBASSY.

 Wheel SUBASSY : 225 kg (496 lbs.)

(NOTICE)

- Take care not to damage threaded portion of the rod (16) when removing parts.

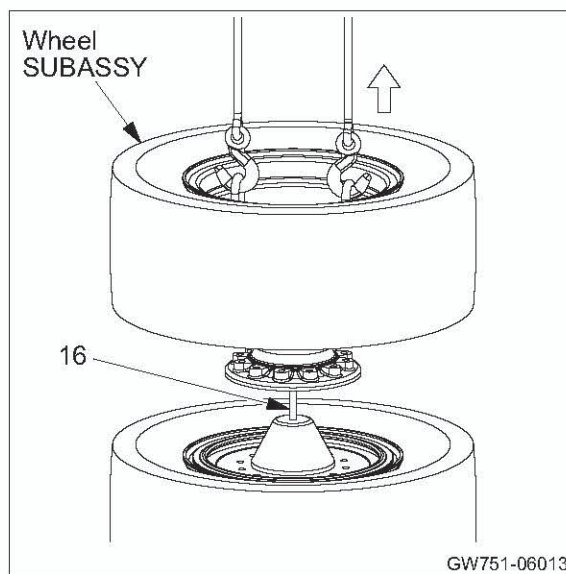

13) Remove tire ASSY (43).

 (43) Tire ASSY : 155 kg (342 lbs.)

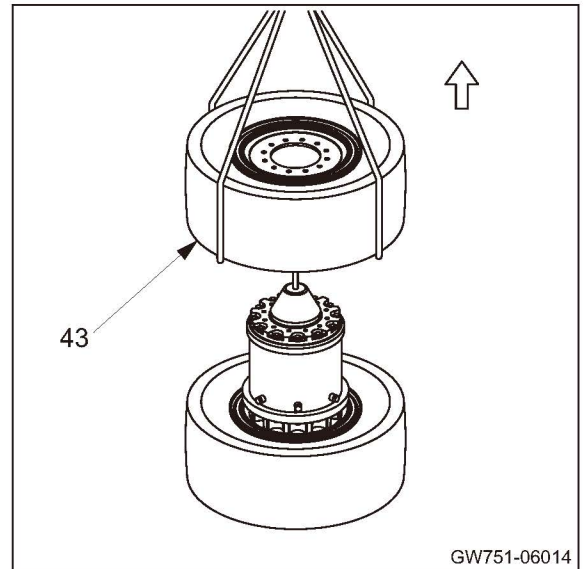

14) Remove bolts (11).

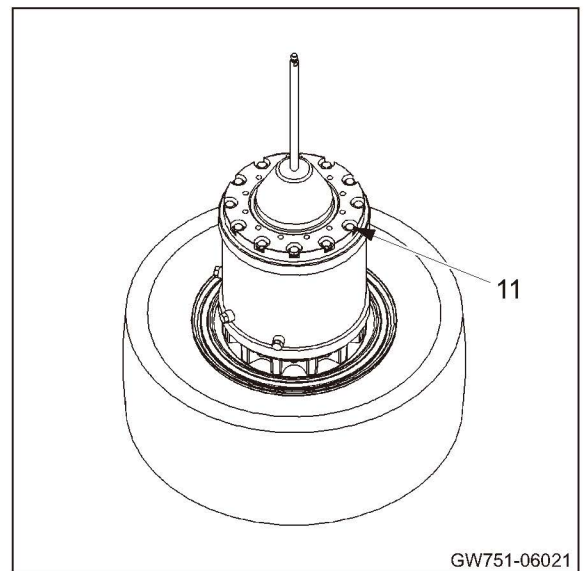

15) Install lifting bolts (M16) to axle SUBASSY.

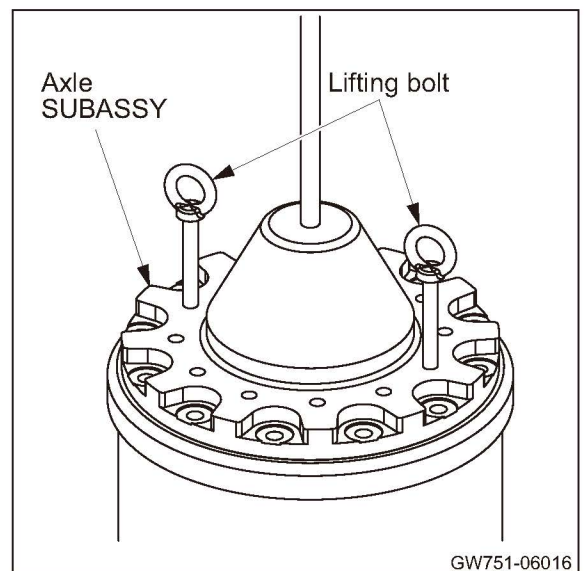

16) Remove axle SUBASSY.

 Axle SUBASSY : 40 kg (88 lbs.)

(NOTICE)

- Take care not to damage threaded portion of the rod (16) when removing parts.

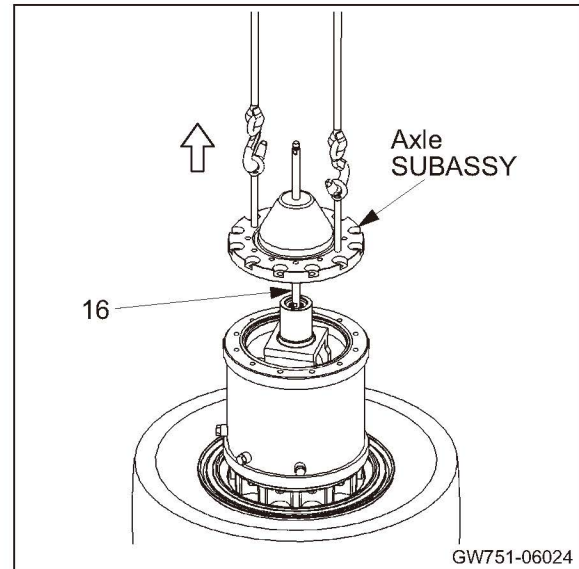

17) Install lifting bolts (M10) to shaft SUBASSY.

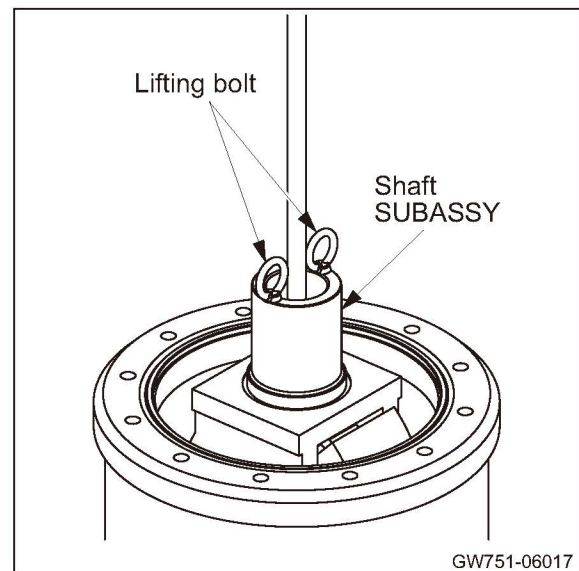

18) Remove shaft SUBASSY.

 Shaft SUBASSY : 75 kg (165 lbs.)

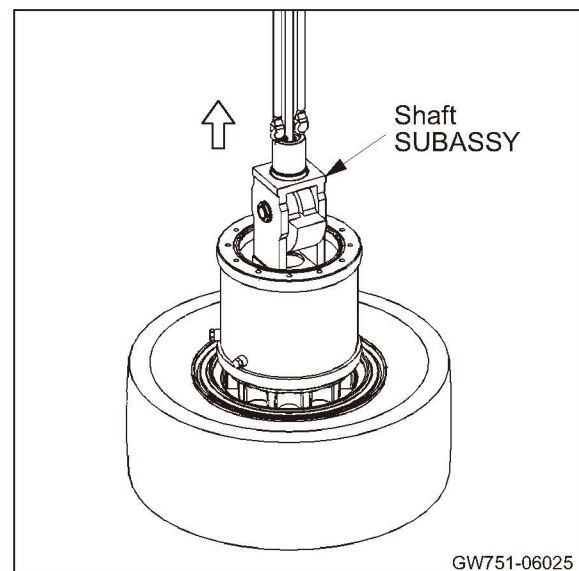

⚠ WARNING

Be careful because reversing the wheel involves risk. Confirm that the surrounding area is safe, and work in a natural, unstrained posture.

19) Reverse wheel SUBASSY.

 Wheel SUBASSY : 320 kg (705 lbs.)

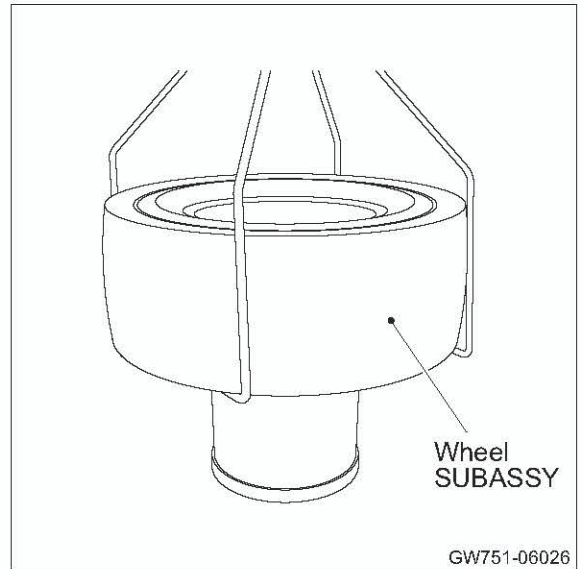

20) Remove adapter (60) and breather (61).

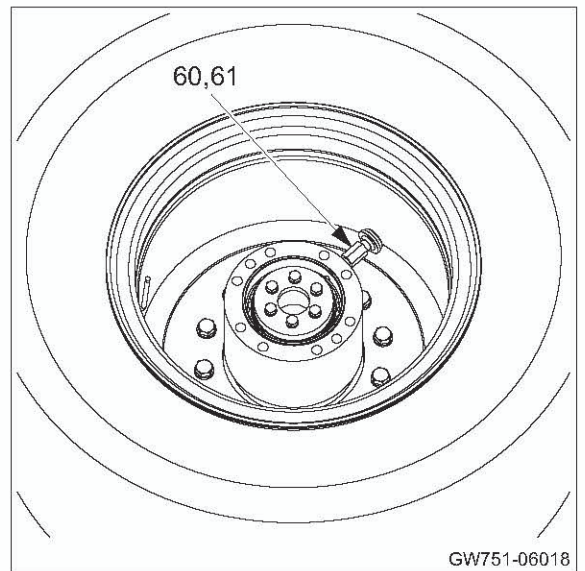

21) Remove bolts (1).

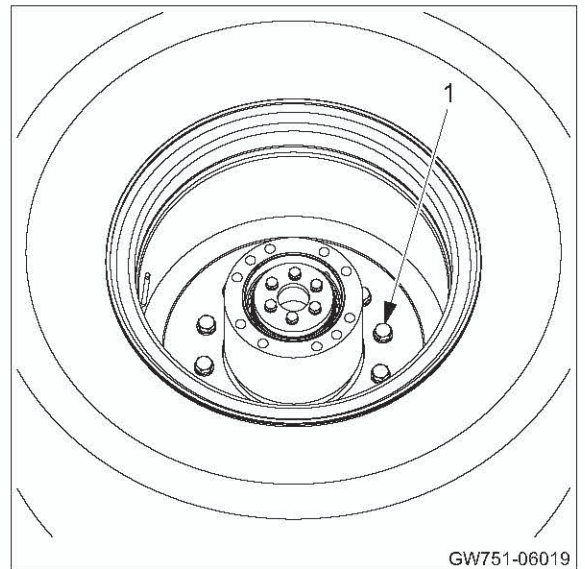

22) Remove tire ASSY (48).

 (48) Tire ASSY : 155 kg (342 lbs.)

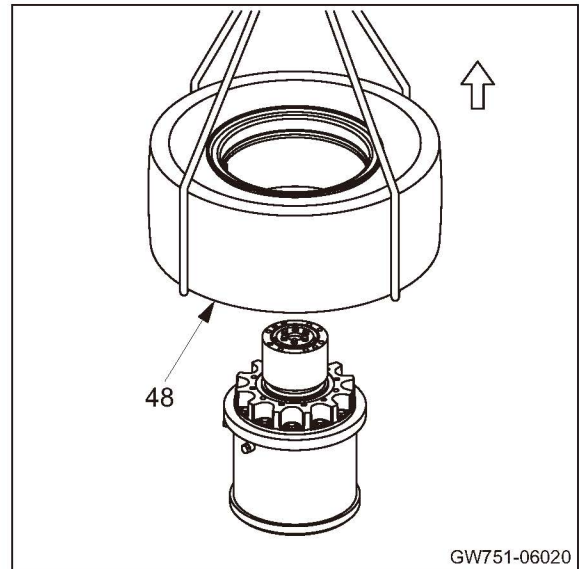

23) Remove bolts (45).

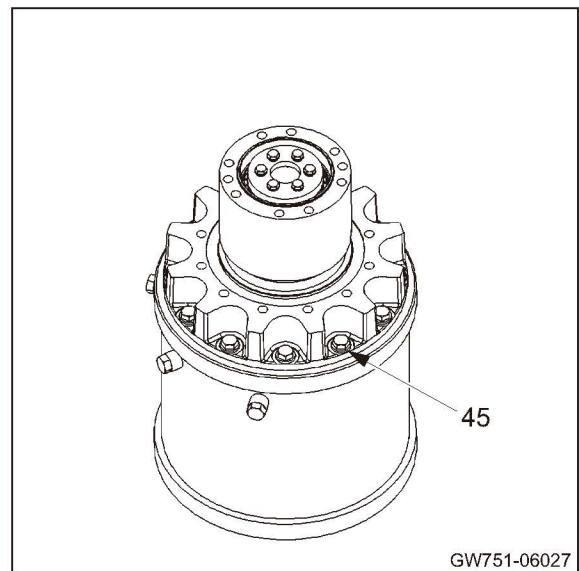

24) Install lifting bolts (M16) to axle SUBASSY.

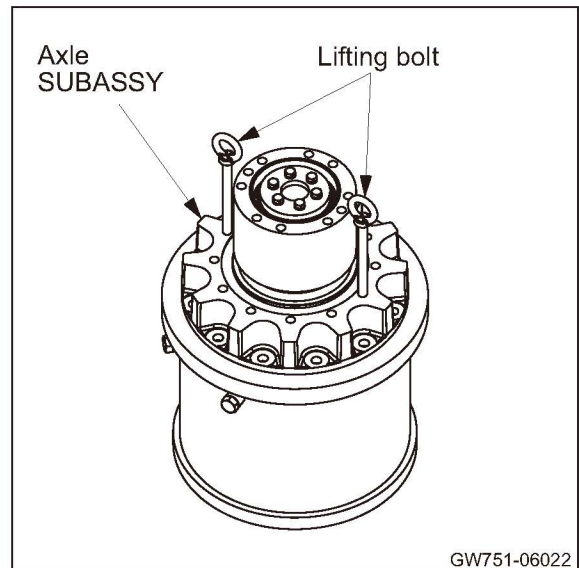

25) Remove axle SUBASSY.

 Axle SUBASSY : 75 kg (165 lbs.)

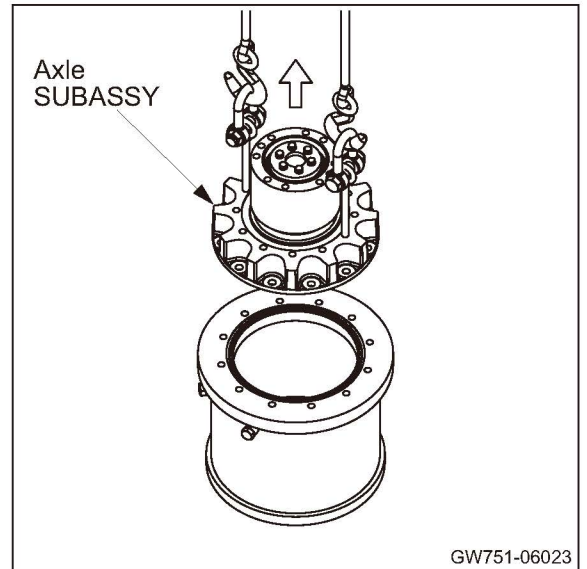

26) Remove bolts (56).

- Remove cover (52).
- Remove shim (54).

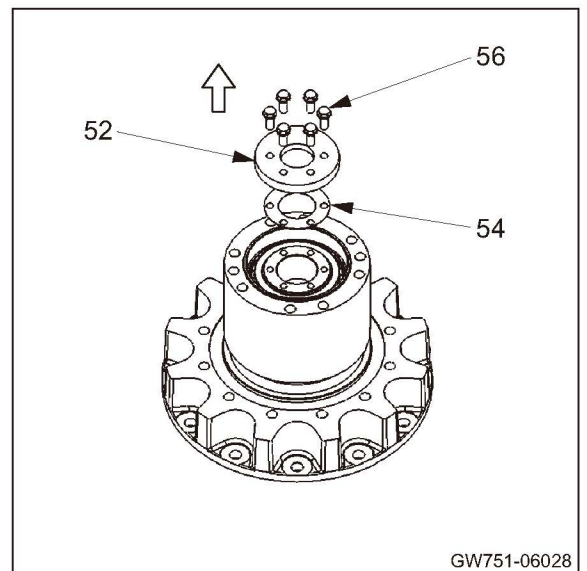

27) Put a piece of wooden board on end of axle (2).

- Set a puller on housing (47).
- Remove housing SUBASSY with roller bearing from axle SUBASSY.

 Housing SUBASSY : 25 kg (55 lbs.)

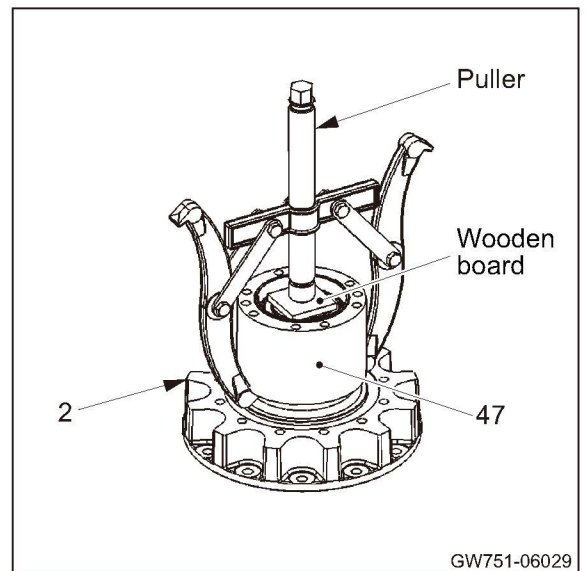

2-3-2. Reassembly of front wheel

- Before reassembling, clean disassembled parts well and check that there is no abnormality.

1) Reassembly of axle SUBASSY

1-1) Apply a coat of gear oil to axle (2) at where bearing will be press-fitted.

- Drive vibrator bearing (46) into axle.

(NOTICE)

- Take care not to damage the bearing when installing it.

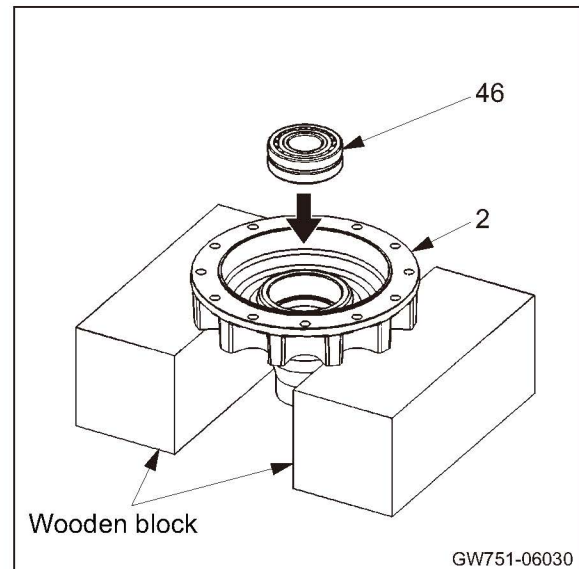

1-2) Reverse axle SUBASSY.

\mathcal{J}_{kg} Axle SUBASSY : 50 kg (110 lbs.)

- Apply a coat of gear oil to axle (2) at where bearing will be press-fitted.
- Drive roller bearing (63) inner race into axle.

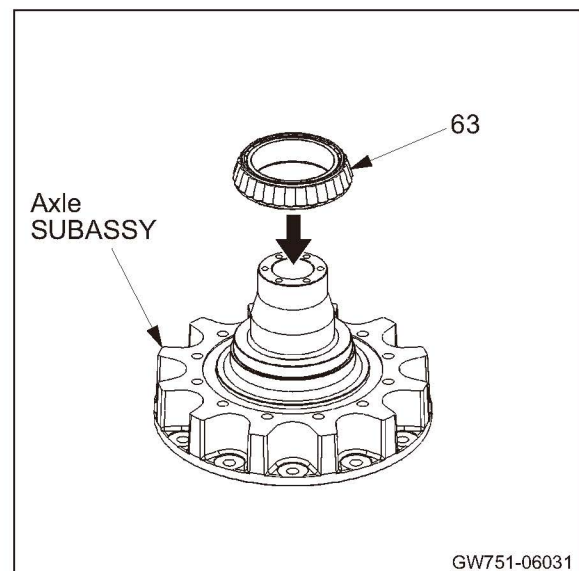

1-3) Apply a coat of gear oil to housing (47) at where bearing outer races will be press-fitted.

- Drive roller bearings (59) and (63) outer races into housing.
- Apply liquid packing to periphery of oil seal (64).
- Drive oil seal into housing.
- Apply grease to lip of oil seal.

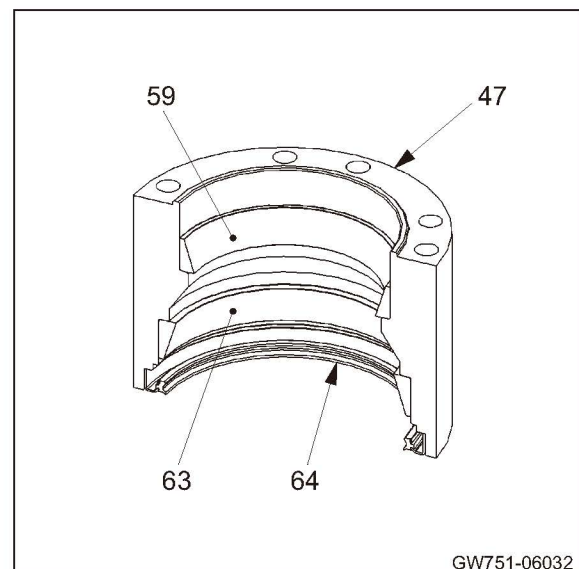

- 1-4) Apply sufficient amount of lithium-based grease to rollers of roller bearing (63) inner race.
- Install housing SUBASSY to axle SUBASSY.

 k_g Housing SUBASSY : 20 kg (44 lbs.)

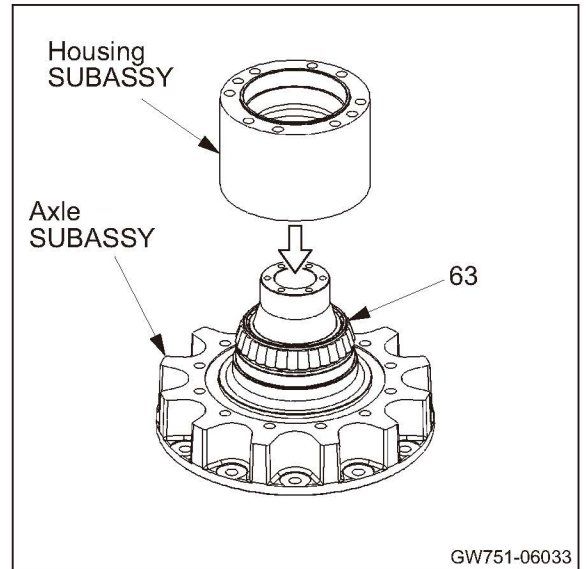

- 1-5) Apply a coat of gear oil to axle (2) at where bearing will be press-fitted.
- Apply sufficient amount of lithium-based grease to rollers of roller bearing (59) inner race.
- Drive in roller bearing inner race until rollers come in contact with outer race.

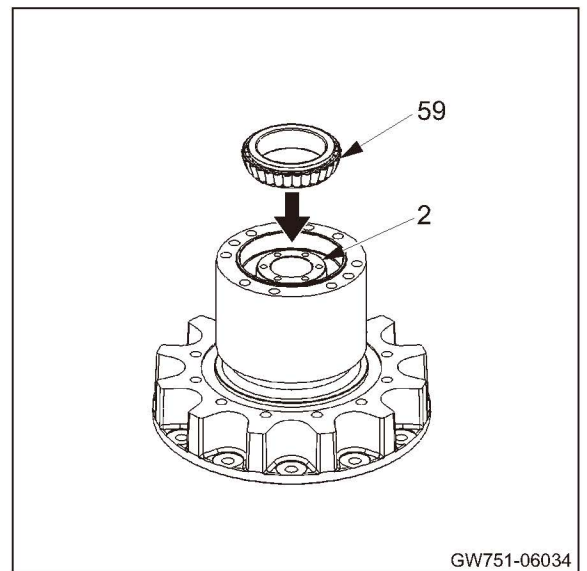

- 1-6) Preload adjustment of roller bearing
- ① Install cover (52) to axle (2) with six bolts (56) and spring washers.
- Tighten bolts to a torque of 29 N·m (21 lbf·ft).
- Give housing (47) two to three turns.
- Tighten bolts to a torque of 29 N·m (21 lbf·ft) again.
- Repeat this work several times until tightening torque of bolts no longer fluctuates.

(NOTICE)

- Tighten the bolts alternately in diagonal directions.

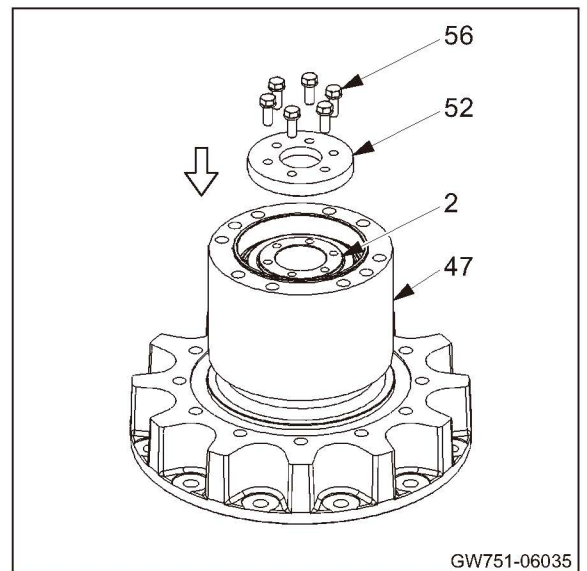

(NOTICE)

- Push in the inner race while rotating the bearing. Otherwise, even strongly trying to push the inner race, the bearing rollers will not be pushed up and therefore bearing will not be seated.

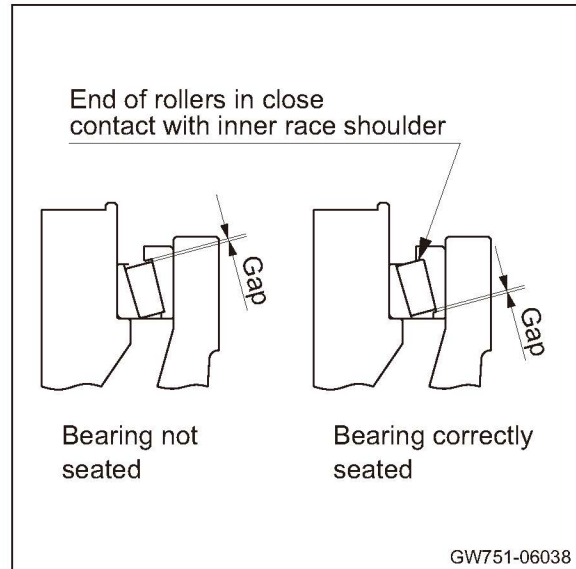

- ② Remove bolts (56).
 - Remove cover (52).

(NOTICE)

- Do not turn the housing (47) after the cover is removed.

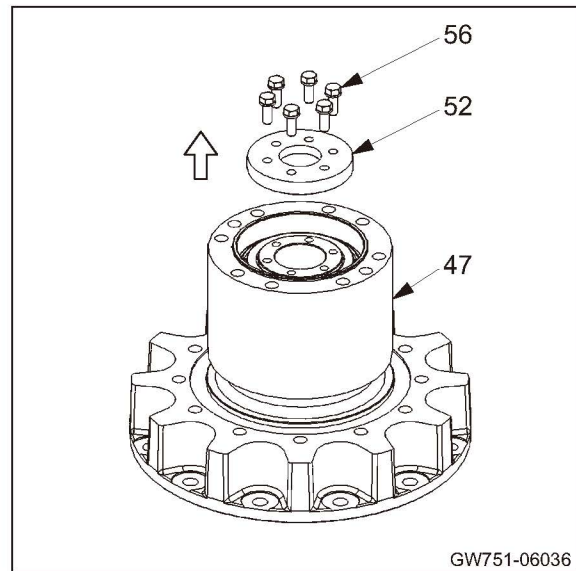

- ③ Measure dimension "a" between axle (2) end face and roller bearing (59) at three points, and calculate average of measurements.

★ Reference dimension a: 3.9 to 4.3 mm (0.15 to 0.17 in.)

- Measure dimension "b" inside of cover (52).

★ Preload adjusting shim thickness = $(b-a) - 0.1 \text{ mm (0.004 in.)}$

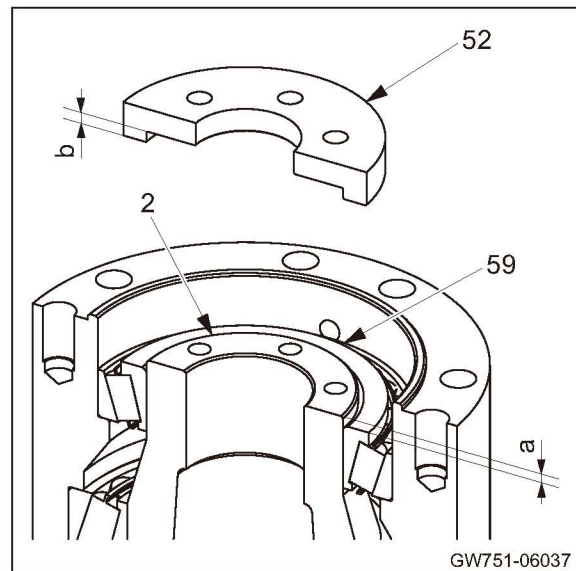

- ④ Install shim (54) of preload adjusting shim thickness = “(b-a) - 0.1 mm (0.004 in.)”.
- Secure cover (52) to axle (2) with six bolts (56) and spring washers.



(56) Bolts M10×30 : 59 N·m (44 lbf·ft)

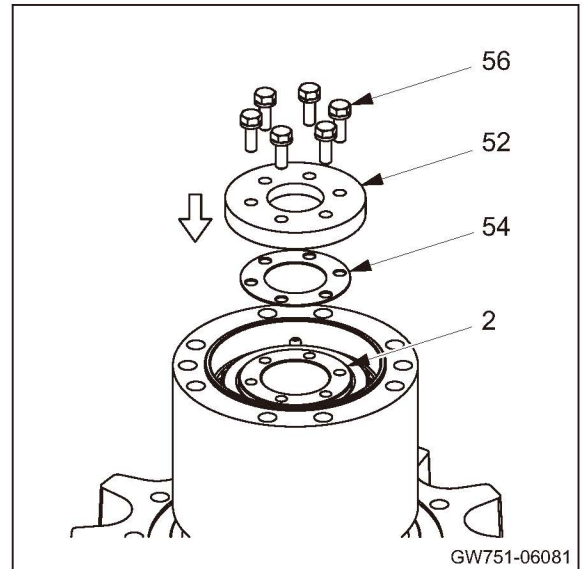

⚠ WARNING

When installing lifting bolts, screw in the threads fully before using.

1-7) Install lifting bolts (M16) to axle SUBASSY.

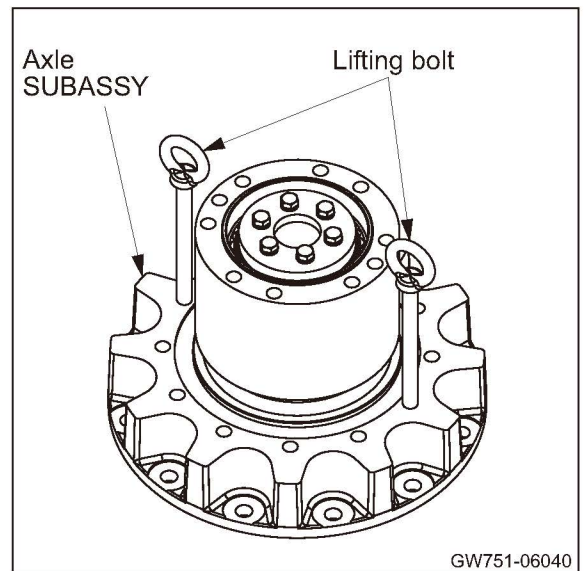

1-8) Apply grease to O-ring (42).

- Install O-ring to case (4).

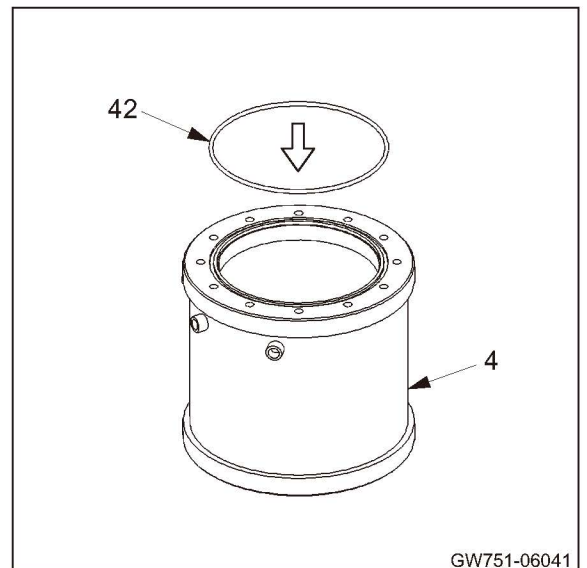

1-9) Lower axle SUBASSY on mounting surface of case (4).

 Axle SUBASSY : 75 kg (165 lbs.)

(NOTICE)

- Take care not to let O-ring to protrude from its groove.

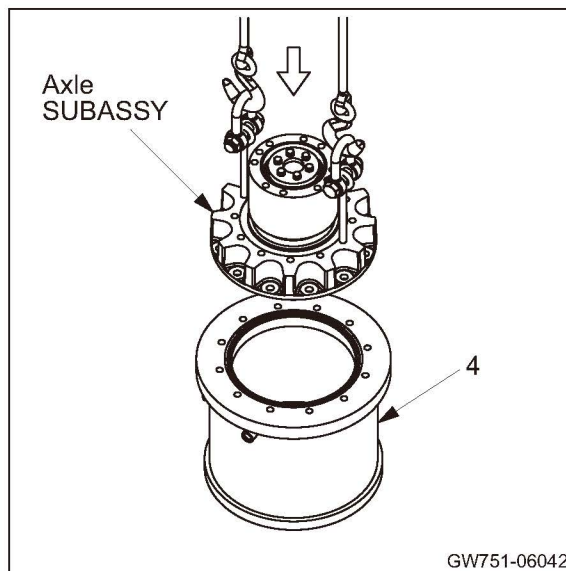

1-10) Secure axle SUBASSY to case (4) with twelve bolts (45) and washers.

 (45) Bolts M16×40 : 265 N·m (195 lbf·ft)

- Apply grease to O-rings for plugs (44).
- Install plugs to case.

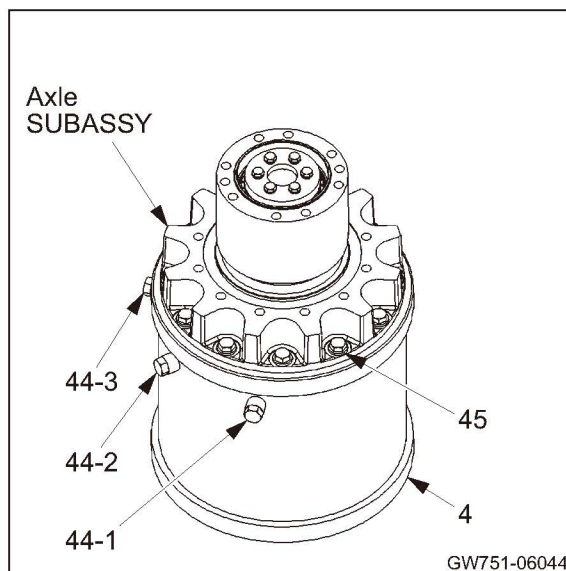

2) Lower tire ASSY (48) on mounting surface of axle (2).

 (48) Tire ASSY : 155 kg (342 lbs.)

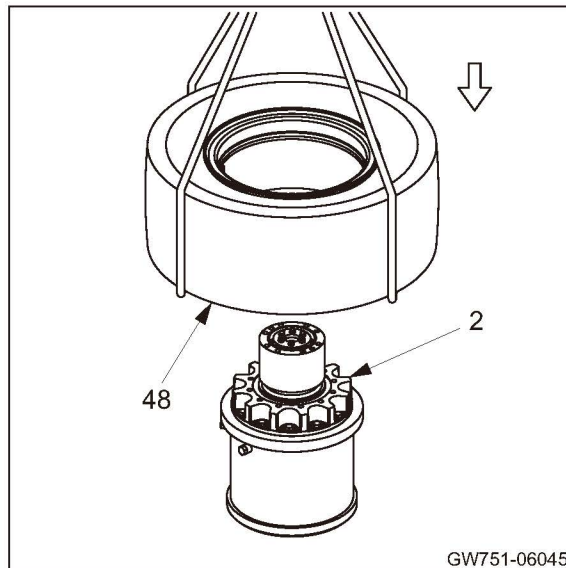

- 3) Secure tire ASSY (48) to axle (2) with twelve bolts (1) and washers.



(1) Bolts M16×35 : 265 N·m (195 lbf·ft)

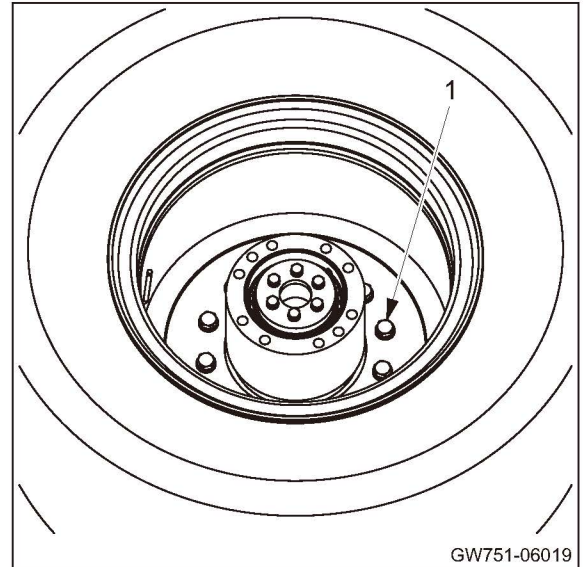

- 4) Wind seal tape around threaded portion of breather (61).
 - Install breather to adapter (60).
 - Wind seal tape around threaded portion of adapter.
 - Install breather SUBASSY to housing (47).

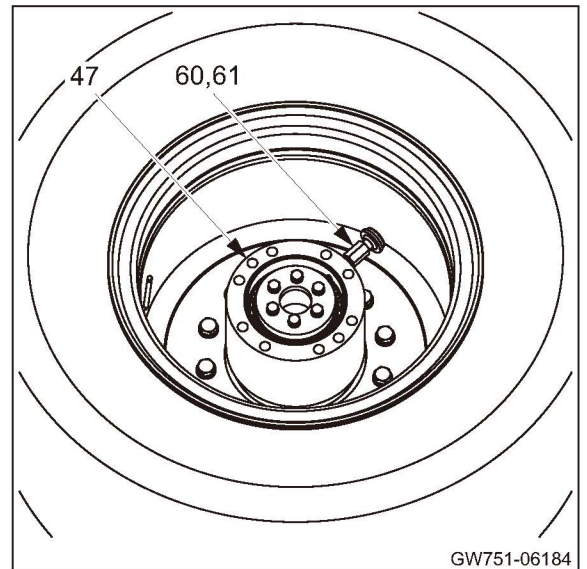

⚠ WARNING

Be careful because reversing the wheel involves risk. Confirm that the surrounding area is safe, and work in a natural, unstrained posture.

- 5) Reverse wheel SUBASSY.



Wheel SUBASSY : 320 kg (705 lbs.)

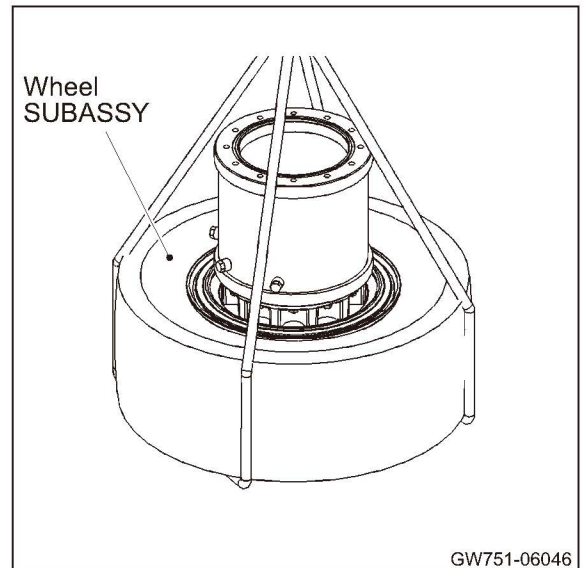

6) Reassembly of shaft SUBASSY

6-1) Secure shaft (50) to shaft (3) with six bolts (49).

 (49) Bolts 3/8-16UNC×1 1/4 in.
: 59 N·m (44 lbf·ft)

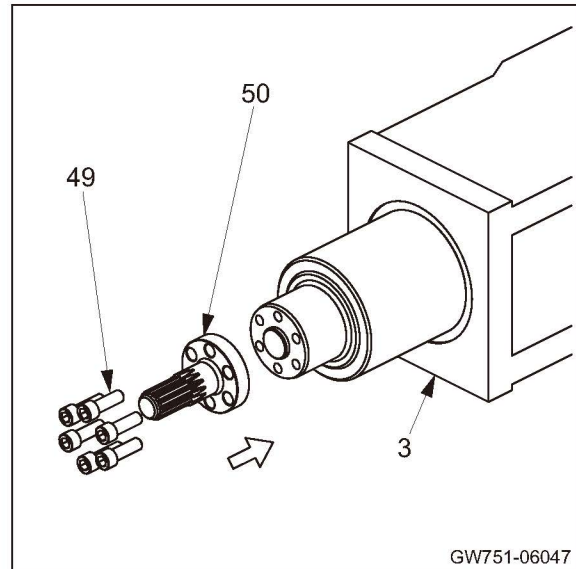

6-2) Align pin (10) mounting hole in arm (8) with pin mounting hole in guide (12).

- Install pin to guide.
- Stake edge of each pin mounting hole at top and bottom of guide at three points.

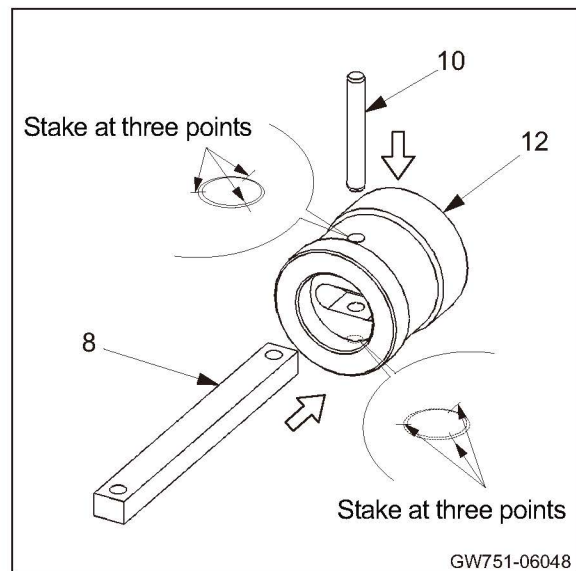

6-3) Apply a coat of gear oil to weight (5) at where bearing will be press-fitted.

- Drive roller bearing (66) into weight.

(NOTICE)

- Take care not to damage the bearing when installing it.
- Drive spring pin (71) into weight.

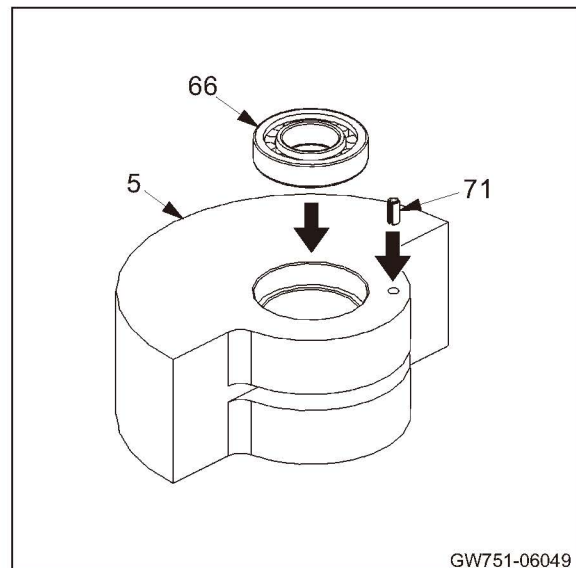

6-4) Reverse weight SUBASSY.

- Apply a coat of gear oil to weight (5) at where bearing will be press-fitted.
- Drive roller bearing (74) into weight.

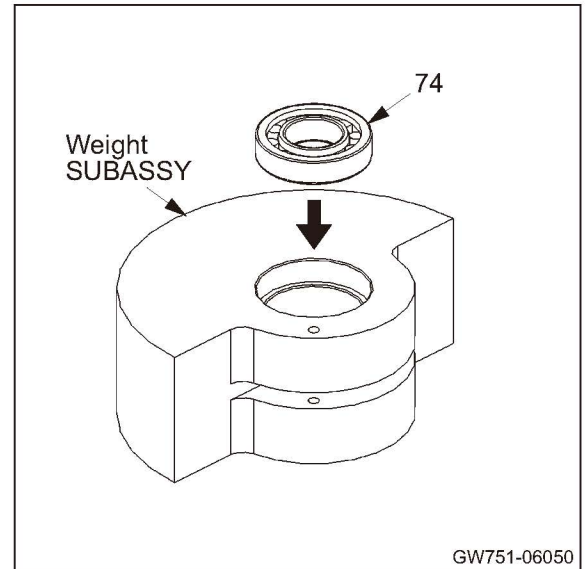

6-5) Align pin (72) mounting hole in arm SUBASSY with pin mounting hole in weight SUBASSY.

- Install pin to weight (5).
- Drive spring pin (73) into weight.

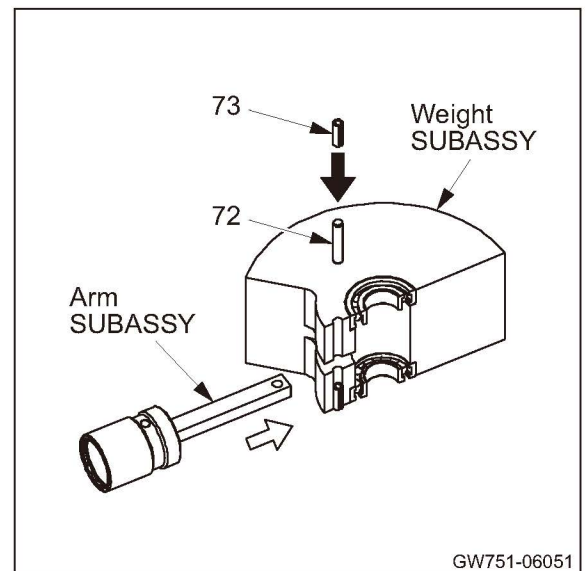

6-6) Apply a coat of gear oil to shaft (3) at where guide (12) will be installed.

- Install weight SUBASSY to shaft SUBASSY.

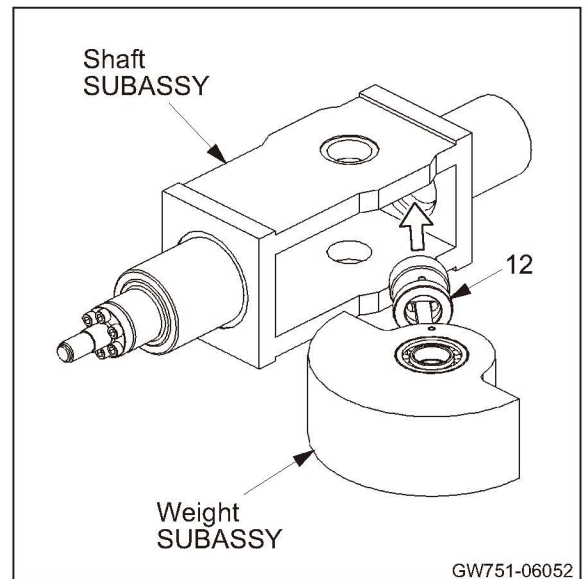

6-7) Install collar (67) to shaft SUBASSY.

- Apply a coat of gear oil to shaft (68).
- Install shaft to shaft SUBASSY with bearing nut (70) and bearing washer (69).

(NOTICE)

- **After installation, make sure that weight SUBASSY moves smoothly.**

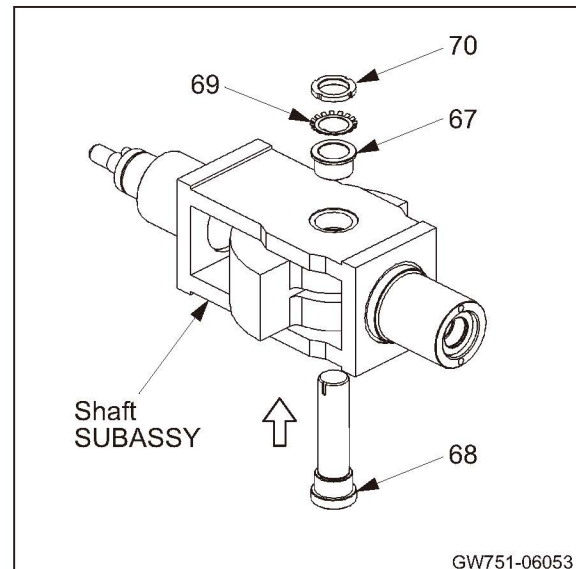

6-8) Apply a coat of gear oil to rod (16) at where bearing will be installed.

- Apply sufficient amount of lithium-based grease to bearing (14).
- Install bearing to rod with nut (13).
- Stake edge of nut at two points.

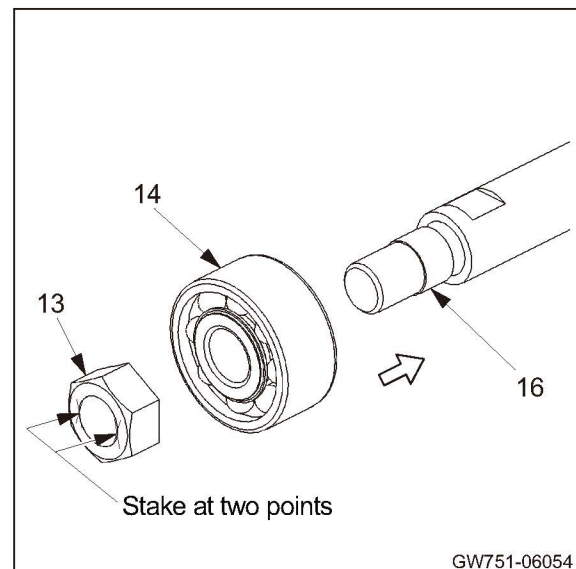

6-9) Apply a coat of gear oil to guide (12) at where bearing will be installed.

- Install rod SUBASSY to shaft SUBASSY.
- Install retaining ring (15) to guide.

(NOTICE)

- **Make sure that the retaining ring is fitted completely in its groove.**

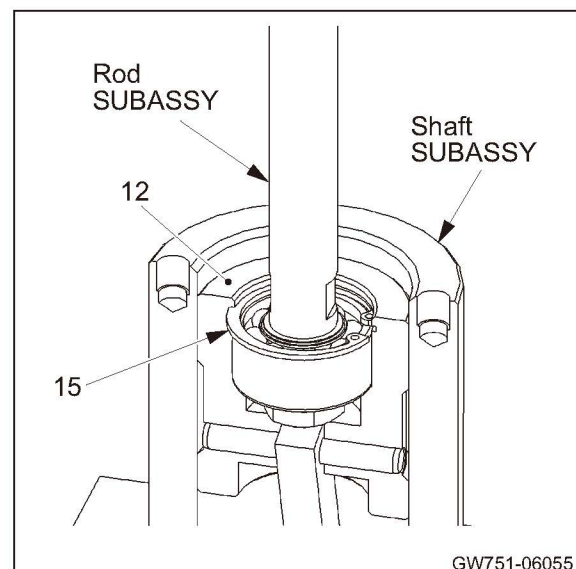

7) Install lifting bolts (M10) to shaft SUBASSY.

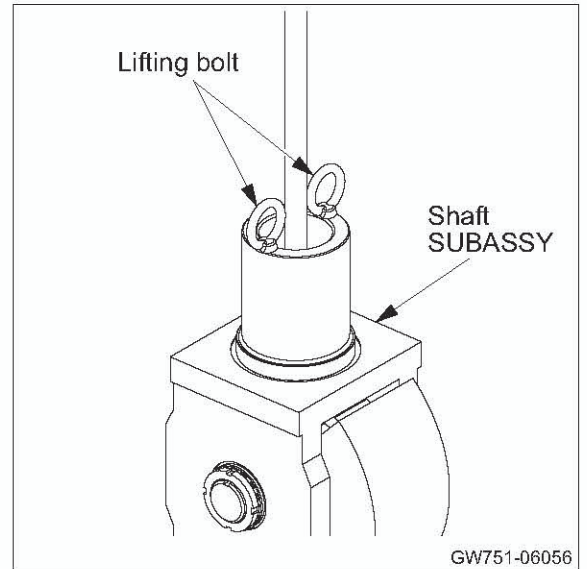

8) Apply a coat of gear oil to shaft (3) at where bearing will be installed.

- Install shaft SUBASSY to wheel SUBASSY.

 Shaft SUBASSY : 75 kg (165 lbs.)

(NOTICE)

- Insert shaft SUBASSY into vibrator bearing (46) while taking care not to tilt vibrator bearing inner race.

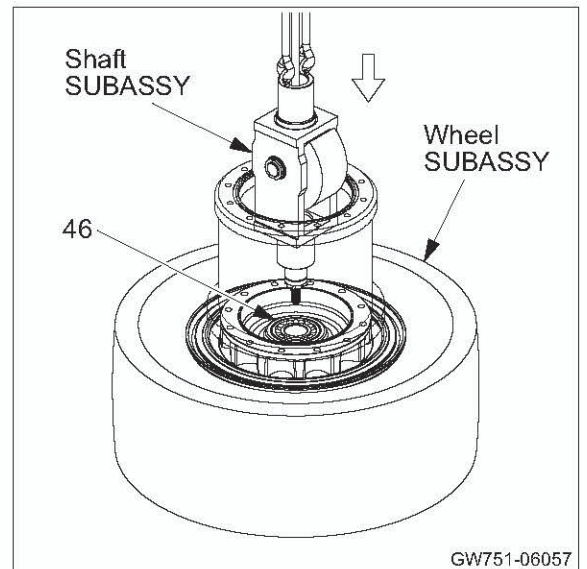

9) Apply a coat of gear oil to axle (6) at where bearing will be press-fitted.

- Install vibrator bearing (9) to axle.

(NOTICE)

- Take care not to damage the bearing when installing it.

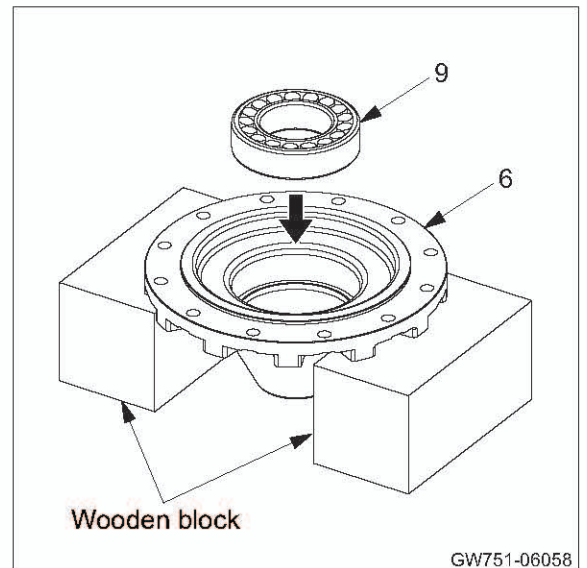

10) Reverse axle SUBASSY.

- Apply grease to O-rings (40).
- Install O-ring to axle (6).
- Install lifting bolts (M16) to axle SUBASSY.

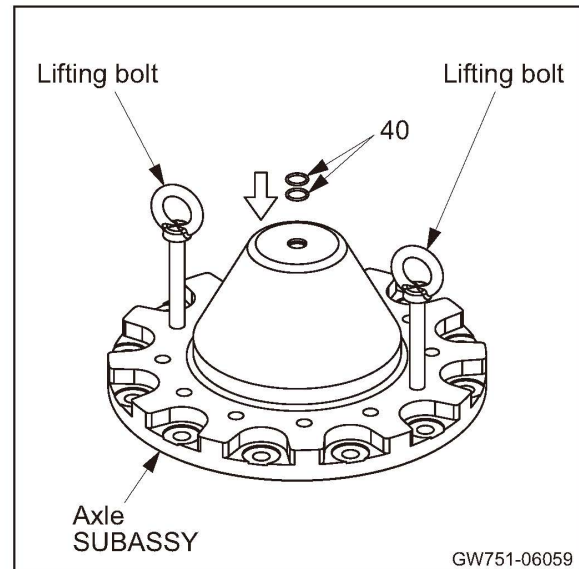

11) Apply grease to O-ring (41).

- Install O-ring to case (4).

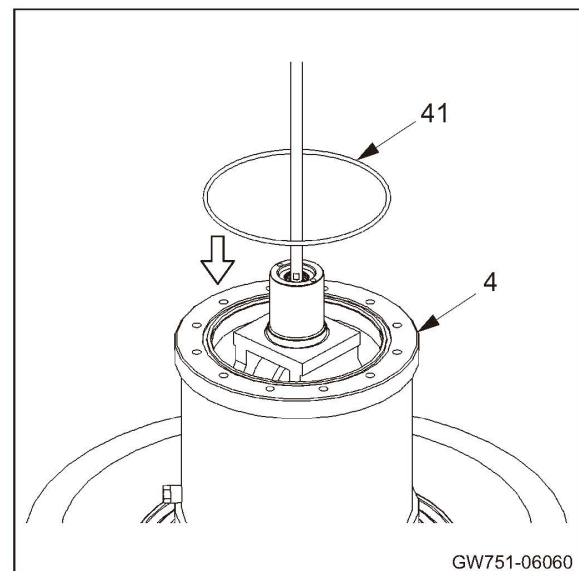

12) Lower axle SUBASSY on mounting surface of case (4).

\mathfrak{J}_{kg} Axle SUBASSY : 40 kg (88 lbs.)

(NOTICE)

- Take care not to damage threaded portion of the rod (16) when installing parts.
- Take care not to let O-rings to protrude from their grooves.

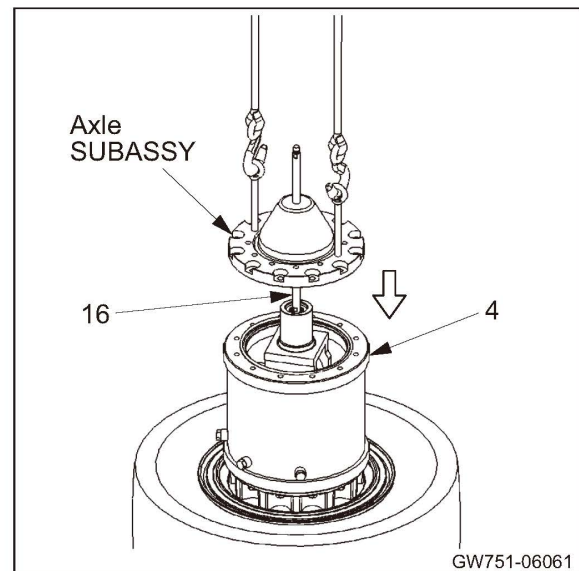

13) Secure axle SUBASSY to case (4) with twelve bolts (11) and washers.



(11) Bolts M16×45 : 265 N·m (195 lbf·ft)

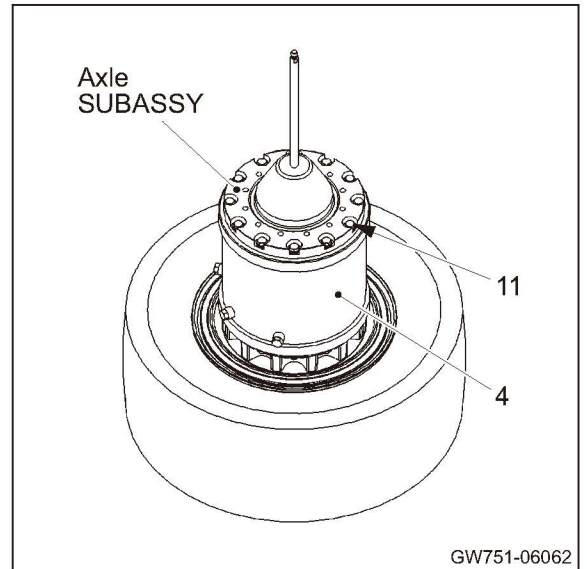

14) Lower tire ASSY (43) on mounting surface of axle (6).



(43) Tire ASSY : 155 kg (342 lbs.)

(NOTICE)

- Apply liquid packing to mating surfaces of tire ASSY and axle.
- Take care not to damage threaded portion of the rod (16) when installing parts.

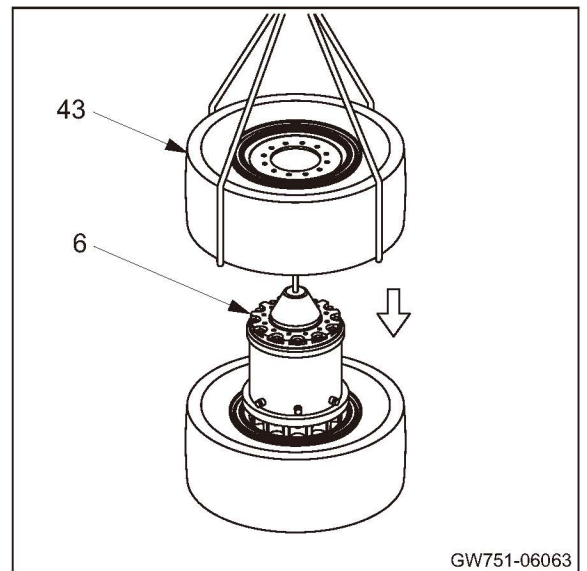

15) Put flange (19) on wooden block.

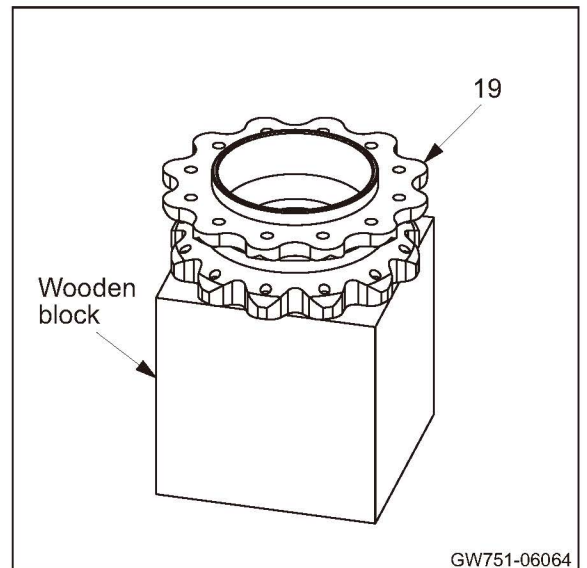

16) Lower tire ASSY (38) on mounting surface of flange (19).

 (38) Tire ASSY : 155 kg (342 lbs.)

(NOTICE)

- Apply liquid packing to mating surfaces of tire ASSY and flange.

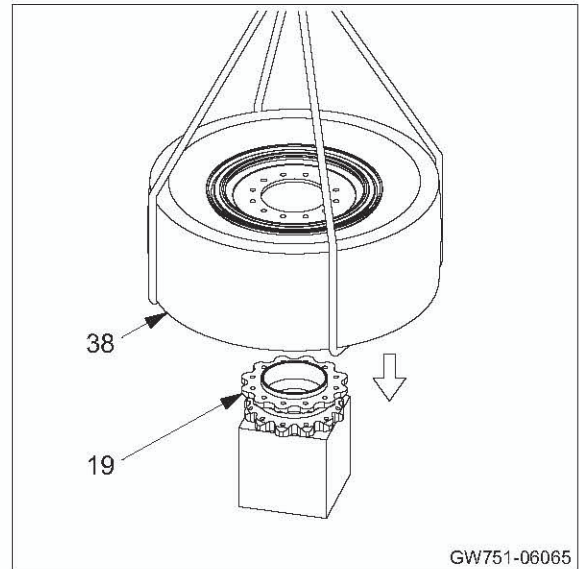

GW751-06065

⚠ WARNING

When installing lifting bolts, secure them with nuts.

17) Install lifting bolts and nuts (M16) to adapter (17).

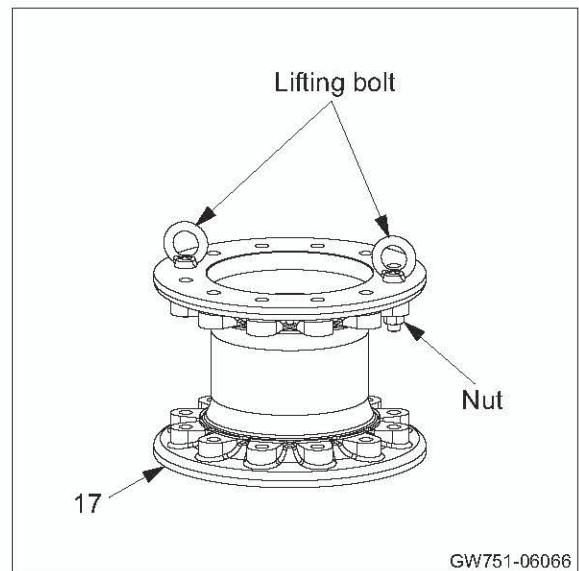

GW751-06066

18) Lower adapter (17) on mounting surface of tire ASSY (38).

 (17) Adapter : 45 kg (99 lbs.)

(NOTICE)

- Apply liquid packing to mating surfaces of tire ASSY and adapter.

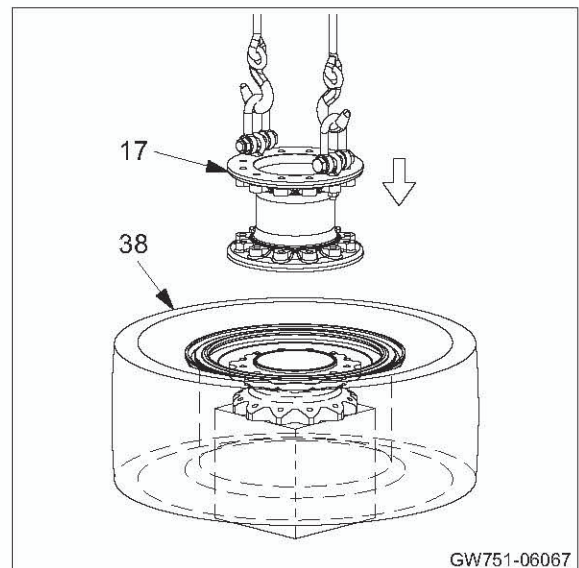

GW751-06067

19) Align mounting holes in adapter (17), tire ASSY (38) and flange (19) with each other.

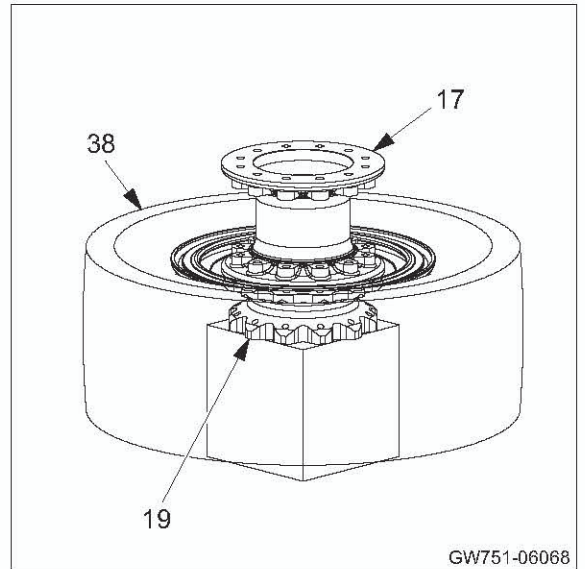

20) Secure adapter (17) and tire ASSY (38) to flange (19) with twelve bolts (18) and washers.



(18) Bolts M16×85 : 265 N·m (195 lbf·ft)

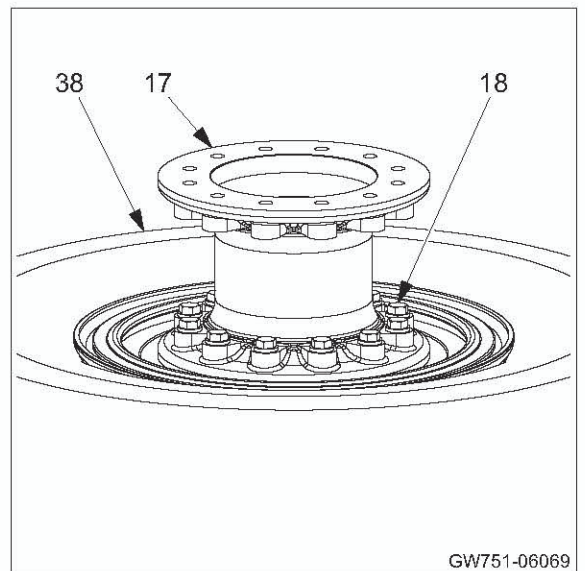

21) Reverse wheel SUBASSY.



Wheel SUBASSY : 225 kg (496 lbs.)

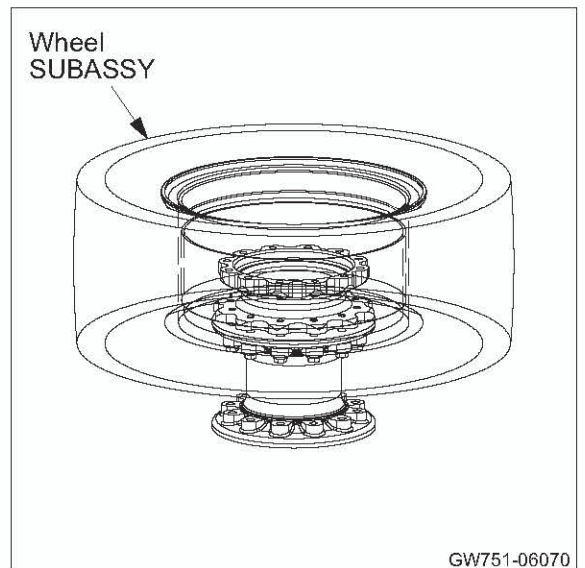

- 22) Install bush (21) to flange (19).
- Stake edge of bush mounting hole of flange at three points.
 - Install lifting bolts (M16) to wheel SUBASSY.

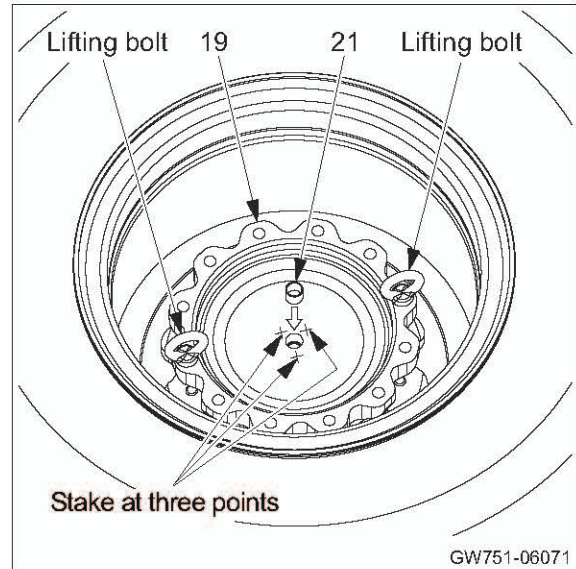

- 23) Lower wheel SUBASSY on mounting surface of tire ASSY (43).

 Wheel SUBASSY : 225 kg (496 lbs.)

(NOTICE)

- Take care not to damage threaded portion of the rod (16) when installing parts.

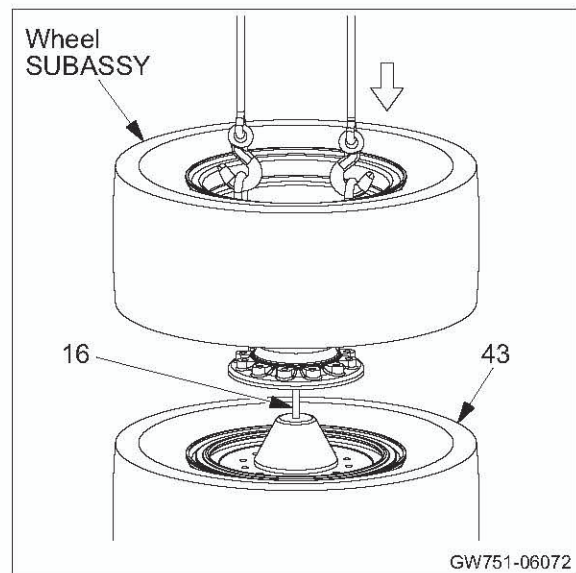

- 24) Secure wheel SUBASSY and tire ASSY (43) to axle (6) with twelve bolts (7) and washers.

 (7) Bolts M16×85 : 265 N·m (195 lbf·ft)

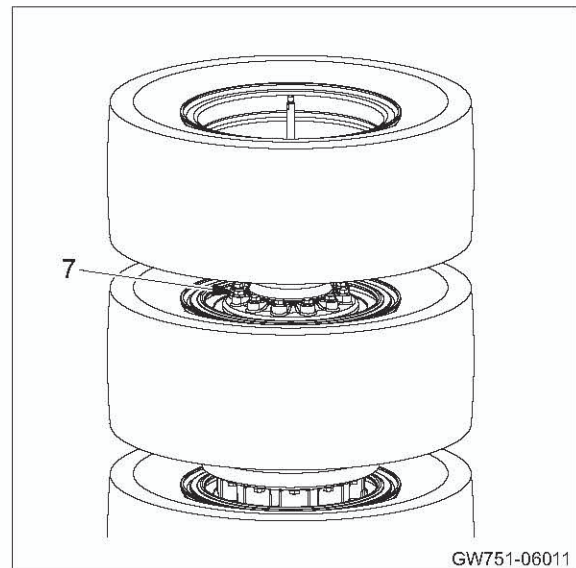

- 25) Apply grease to O-rings for adapters.
- Install adapters to propulsion motor (39).
 - Install lifting bolts (M16) to propulsion motor.

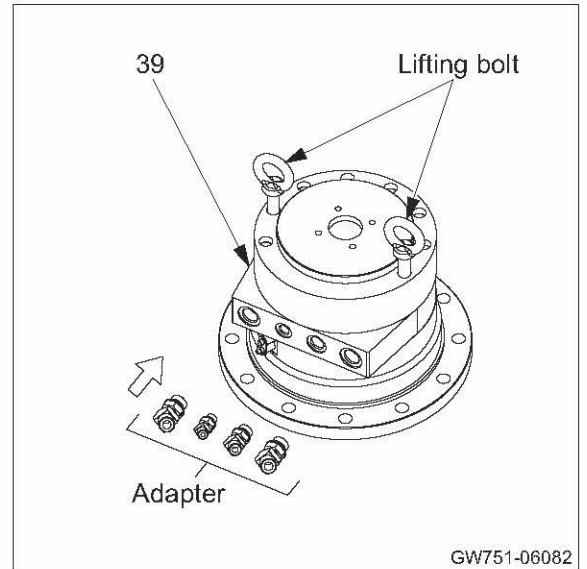

26) Lower propulsion motor on mounting surface of flange (19).

 (39) Propulsion motor : 80 kg (176 lbs.)

(NOTICE)

- Take care not to damage threaded portion of the rod (16) when installing parts.

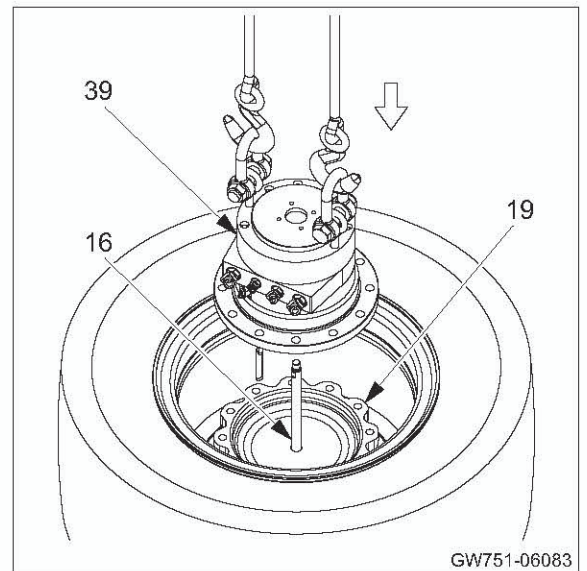

27) Secure propulsion motor to flange (19) with nine bolts (20) and washers.

 (20) Bolts M16×50 : 265 N·m (195 lbf·ft)

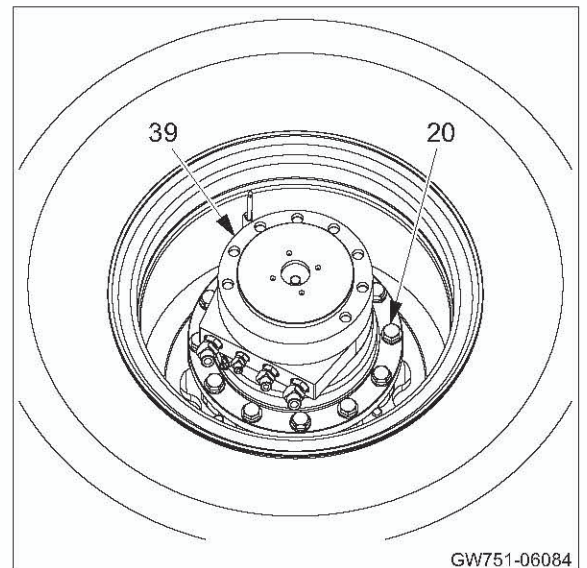

28) Lay wheel SUBASSY.

- Hold with chocks.

 Wheel SUBASSY : 895 kg (1,973 lbs.)

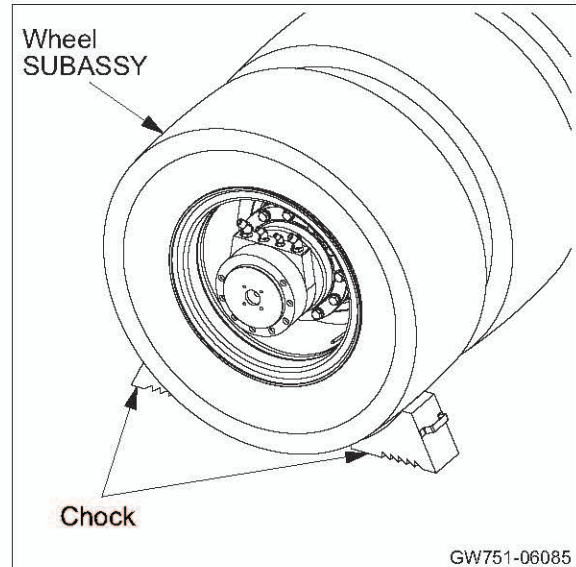

GW751-06085

29) Lift plate (26).

- Secure plate to propulsion motor (39) with eight bolts (31) and washers.

 (26) Plate : 70 kg (154 lbs.)

 (31) Bolts M16×110 : 265 N·m (195 lbf·ft)

(NOTICE)

- Take care not to damage threaded portion of the rod (16) when installing parts.

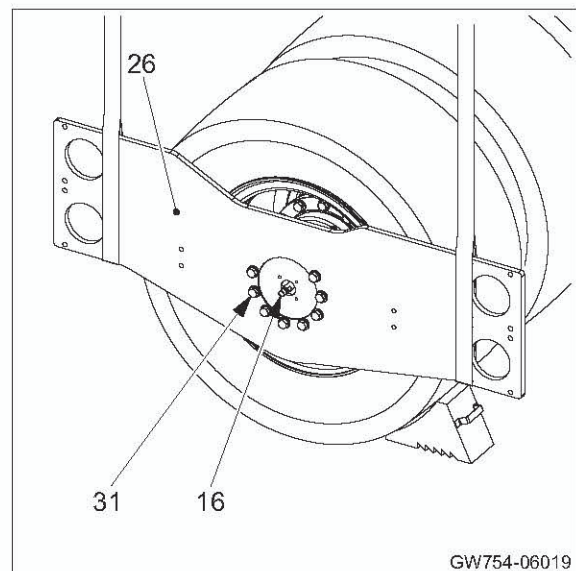

GW754-06019

30) Wind seal tape around threaded portion of adapters.

- Install adapters to amplitude cylinder (29).
- Pull out cylinder rod from amplitude cylinder.
- Install adapter (28) to amplitude cylinder.

(NOTICE)

- Apply liquid packing to mating surfaces of adapter and amplitude cylinder.

- Apply grease to O-ring (27).
- Install O-ring to adapter.

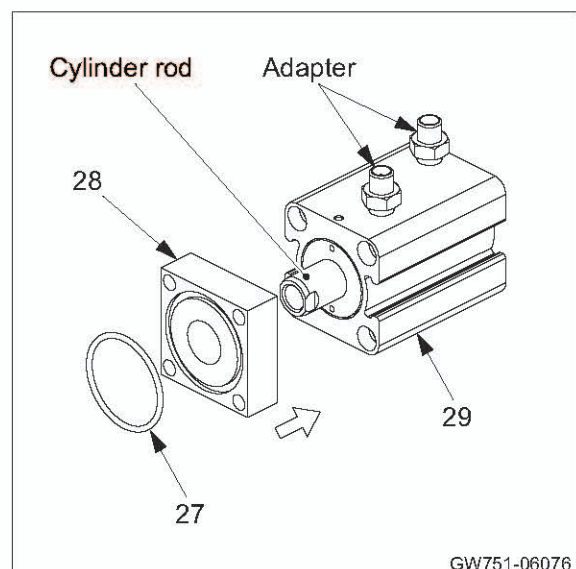

GW751-06076

- 31) Using wrenches, install cylinder rod to rod (16).
- Secure amplitude cylinder SUBASSY to propulsion motor (39) with four bolts (30) and collars.

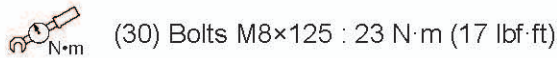

(NOTICE)

- Take care not to let O-ring to protrude from its groove.
- Bolts are treated with thread-locking fluid. Use new thread-locking fluid treated bolts for installation.

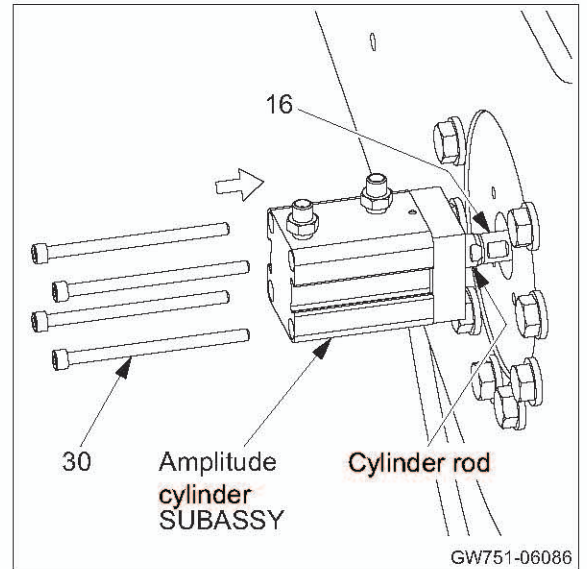

- 32) Make sure that breather (61) is as shown right.

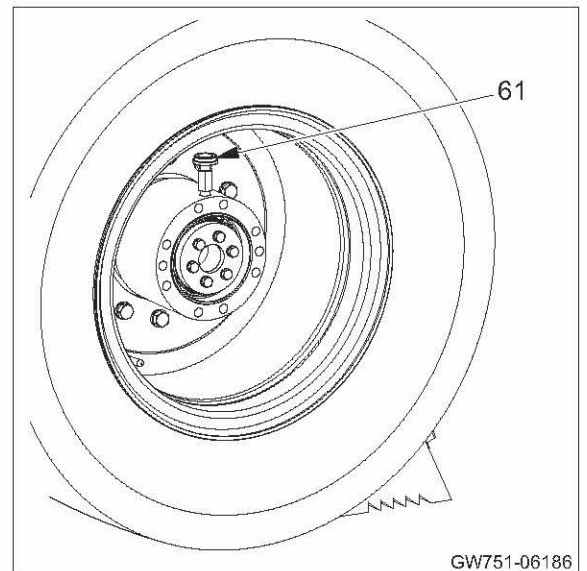

- 33) Lift plate (65).
- Secure plate to housing (47) with ten bolts (51) and washers.

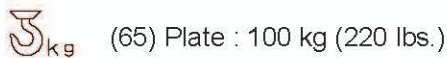

(NOTICE)

- Apply liquid packing to mating surfaces of plate and housing.

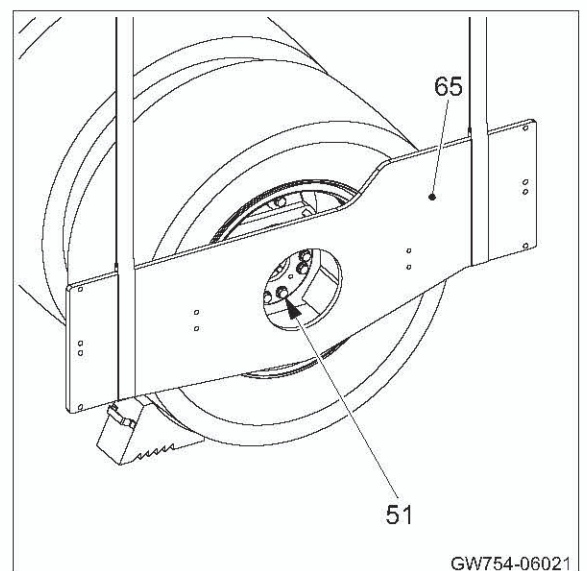

- 34) Apply molybdenum-based grease to splined portion of sleeve (53).
- Fit sleeve to splined portion on shaft (50).

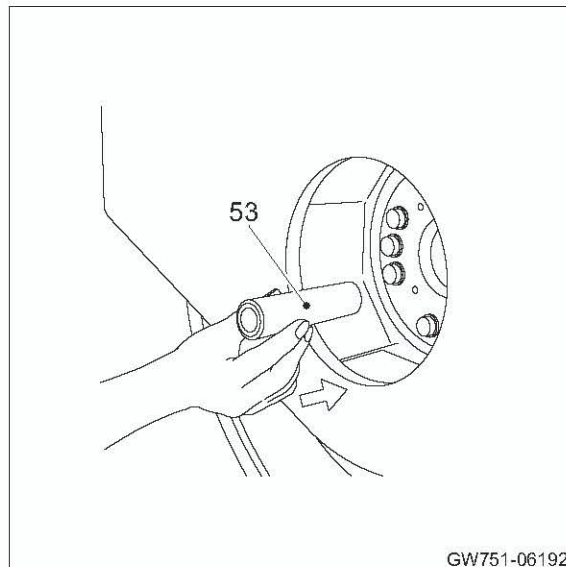

GW751-06192

- 35) Apply grease to O-rings for adapters.
- Install adapters to vibrator motor (55).

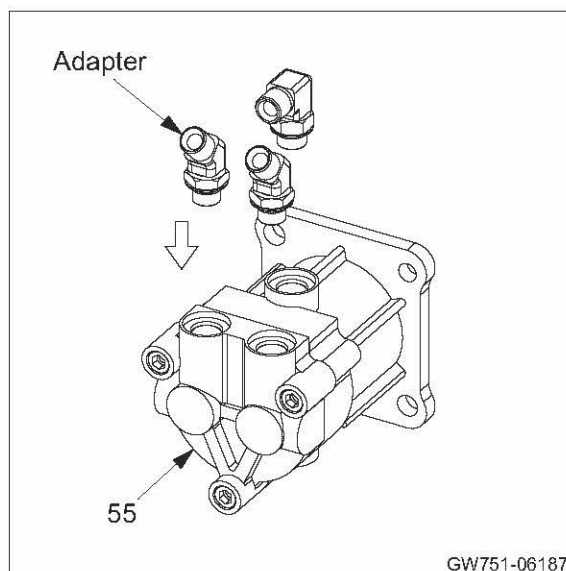

GW751-06187

- 36) Secure vibrator motor (55) to plate (65) with four bolts (57) and washers.



(55) Vibrator motor : 15 kg (33 lbs.)



(57) Bolts M12×30 : 108 N·m (80 lbf·ft)

(NOTICE)

- Apply liquid packing to mating surface of vibrator motor and plate.
- Align the adapters with the breather side when installing the vibrator motor.

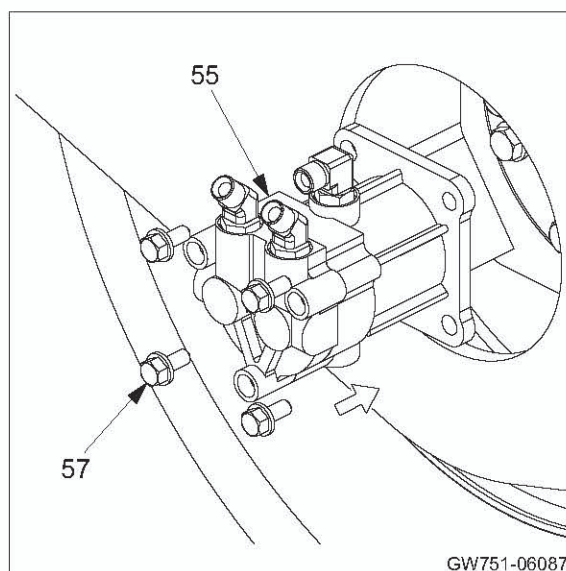

GW751-06087

37) Turn drain plug (44-3) or plug (44-1) to point down.

- Remove plug (44-1).

(NOTICE)

- **When plug (44-1) is pointed down, remove drain plug (44-3).**
- Supply gear oil from oil supply port.
 - Quantity of gear oil : 3.2 L (0.85 gal.)
- Remove level plug (44-2).
- Check that oil drips from port.
- Reinstall plug (44-1) and level plug (44-2) to case (4).

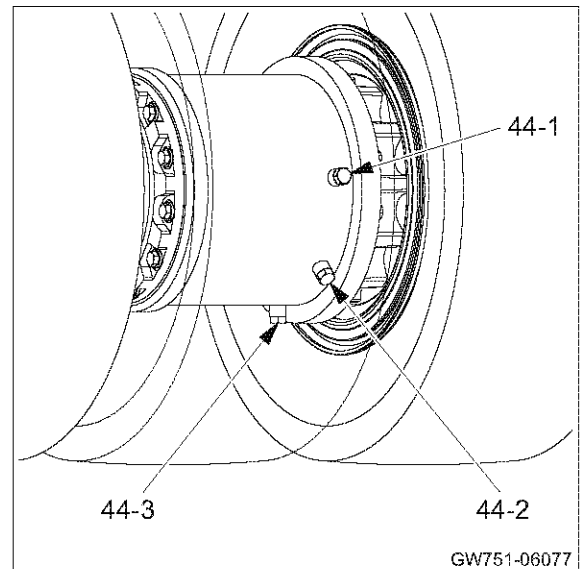

3. REAR WHEEL

3-1. Removal and Installation of Rear Wheel ASSY

3-1-1. Removal of rear wheel ASSY

- 1) Securing machine
 - Hold front wheel with chocks.
 - Lock front and rear frames with steering lock bar (1).

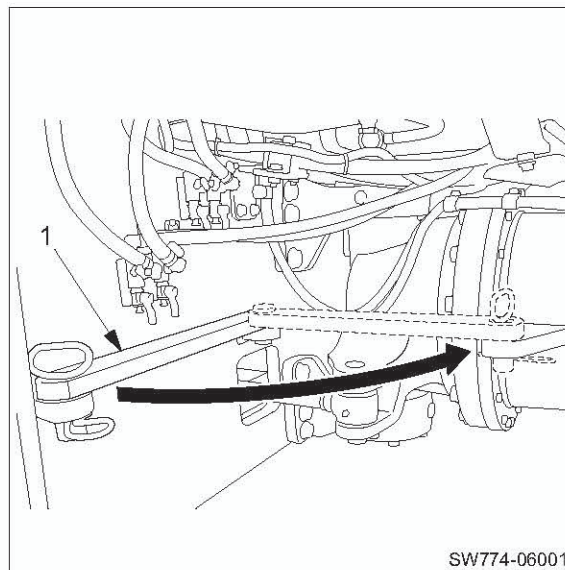

⚠ WARNING

The hydraulic oil in the machine is hot and compressed immediately after the machine is stopped. Disconnecting the hydraulic hoses in this condition can cause burns. Wait for the hydraulic oil to cool down before starting the work.

- 2) Disconnecting piping
 - Disconnect hydraulic hoses (4), (5) and (6) from vibrator motor (R,L).
 - Disconnect hydraulic hoses of vibrator motor (R,R) in same way.

(NOTICE)

- **Plug both ends of the disconnected hoses or implement other actions to prevent entry of foreign matter.**
- Remove hose clamp (2) and (3).
- Remove hose clamp of right side in same way.

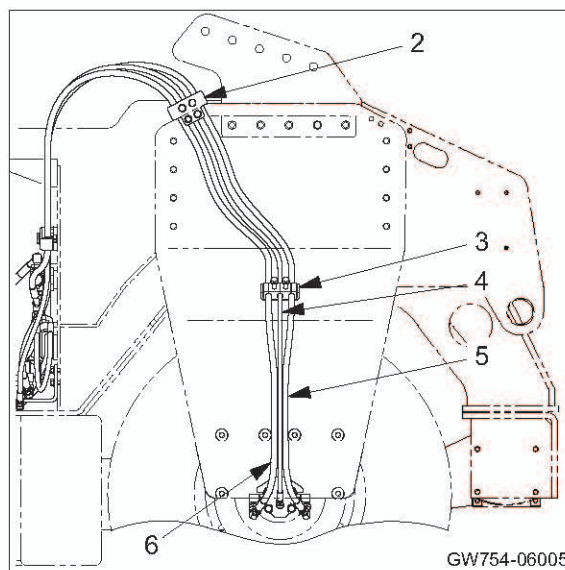

3) Disconnecting amplitude cylinder piping and wiring

3-1) Remove hose clamp (7).

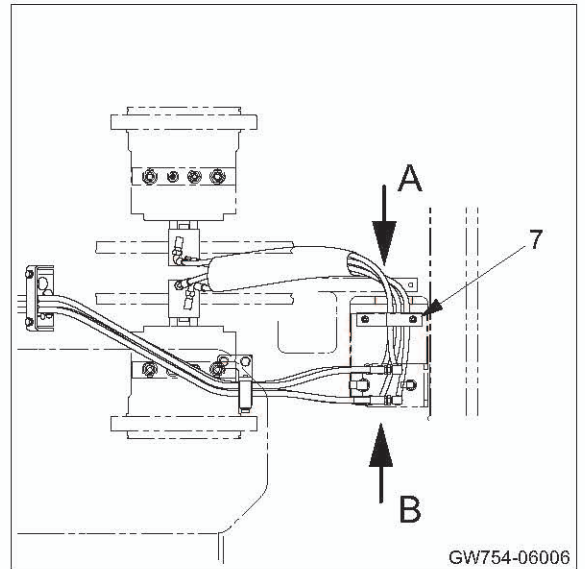

3-2) Disconnect hydraulic hoses (10), (11), (12) and (13) from adapter.

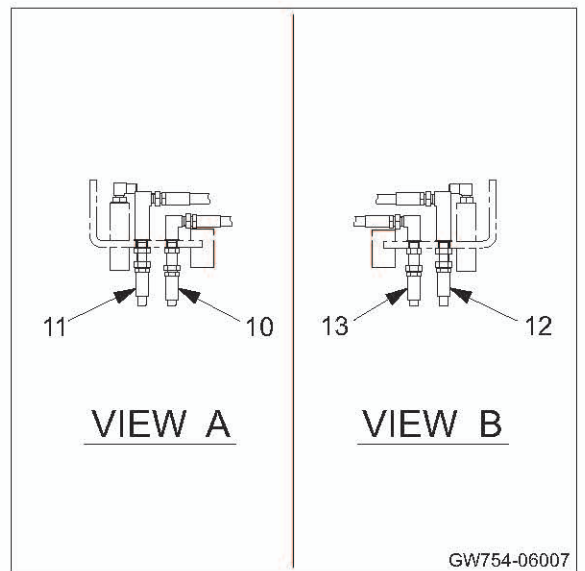

3-3) Disconnect connectors of switch harness (14), (15), (16) and (17).

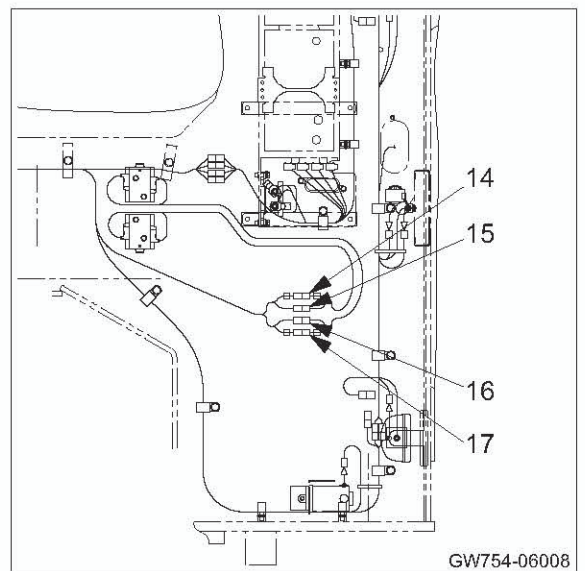

4) Disconnecting propulsion motor piping

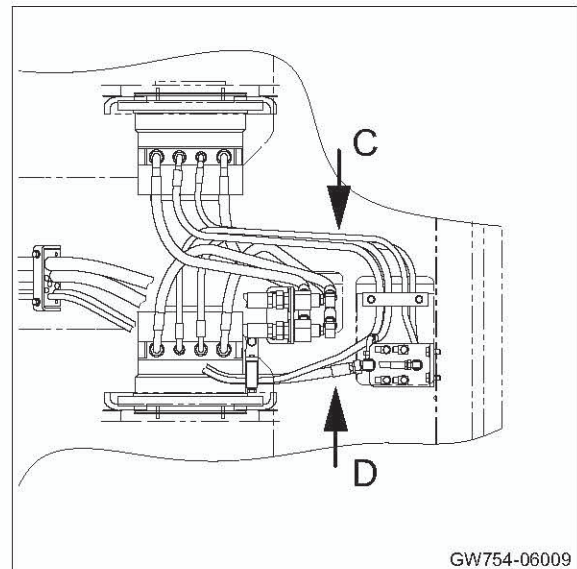

4-1) Disconnect hydraulic hoses (18), (19), (20), (21), (22), (23), (24) and (25) from adapter.

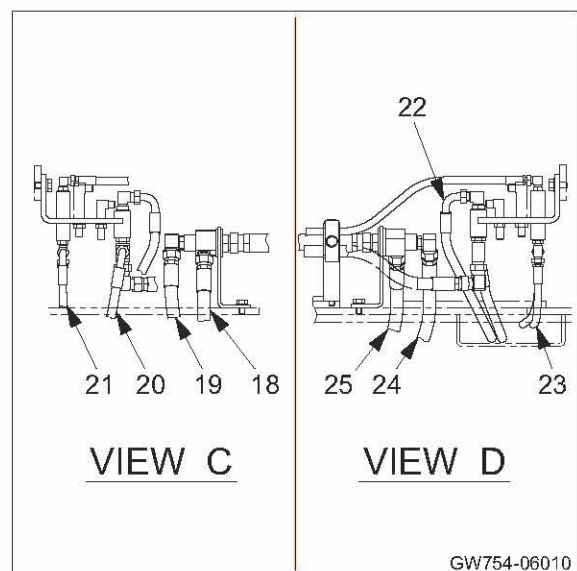

⚠ DANGER

- When lifting the machine body, use an appropriate hoist of sufficient strength. Confirm that the surrounding area is safe, and work in a natural, unstrained posture.
- Also, to firmly secure the machine body, use a support stand of sufficient strength.
- The vehicle must be parked on level place and chock the front wheel with blocks.

5) Supporting frame

- Lift frame with a crane.
- Place support stands under frame when wheel is slightly off ground to support machine body.

 Rear axle weight : 5,170 kg (11,395 lbs.)

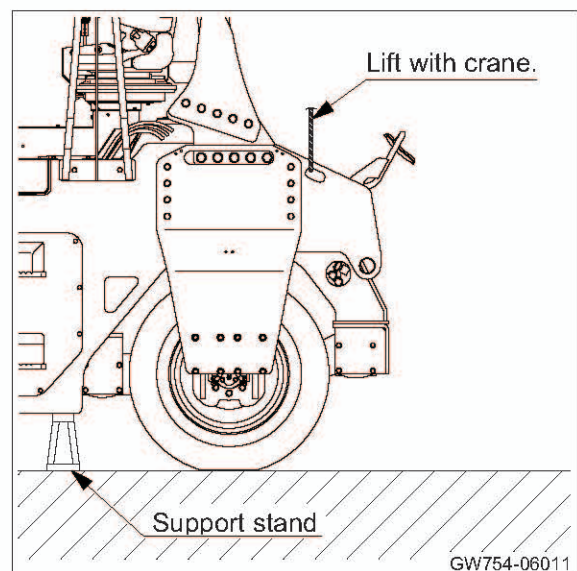

6) Removal of rear wheel ASSY

6-1) Lift side plate (27) with a crane.

- Remove damper mounting bolts (28) and nuts (29) at side plate side .
- Remove side plate mounting bolts (26).
- Remove side plate.
- Remove side plate on other side in same way.

 (27) Side plate : 145 kg (320 lbs.)

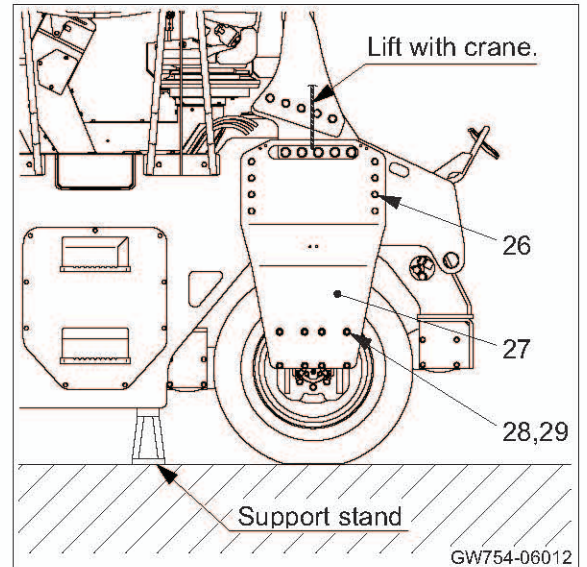

6-2) Remove bolts (31) from bracket (30).

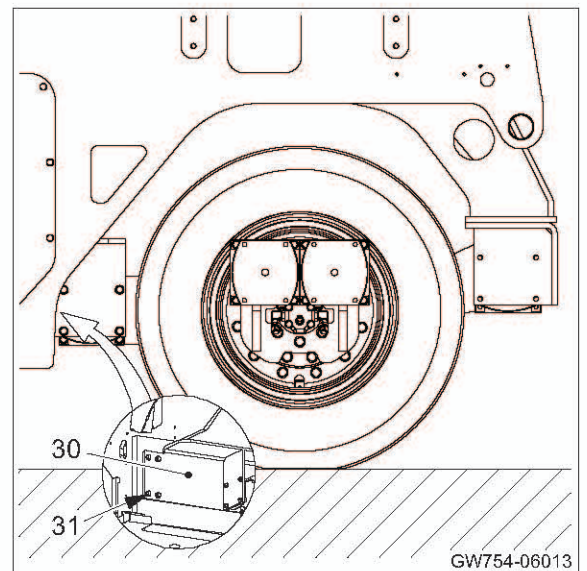

6-3) Remove bolts (33) from bracket (32).

- Lift frame with a crane to secure space enough to pull out rear wheel ASSY (34) sideward.

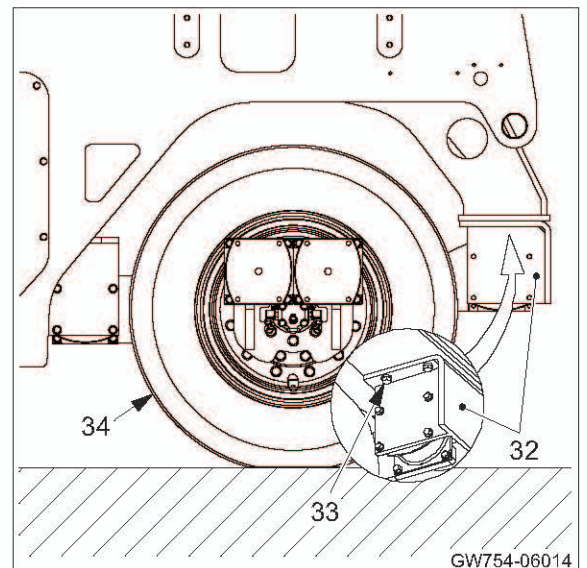

⚠ WARNING

When using a forklift, confirm the safety in the working area, especially surely check the safety in the back area when moving backward.

6-4) Using a forklift, pull out rear wheel ASSY (34) sideward to remove it.

 (34) Rear wheel ASSY : 1,635 kg (3,605 lbs.)

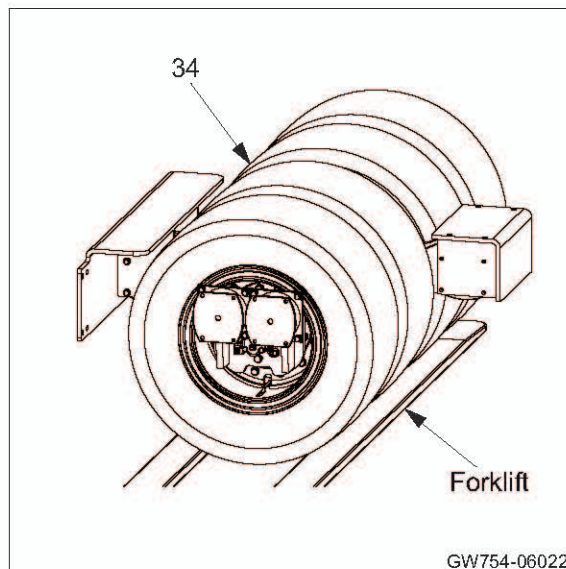

7) Hold rear wheel ASSY (34) with chocks.

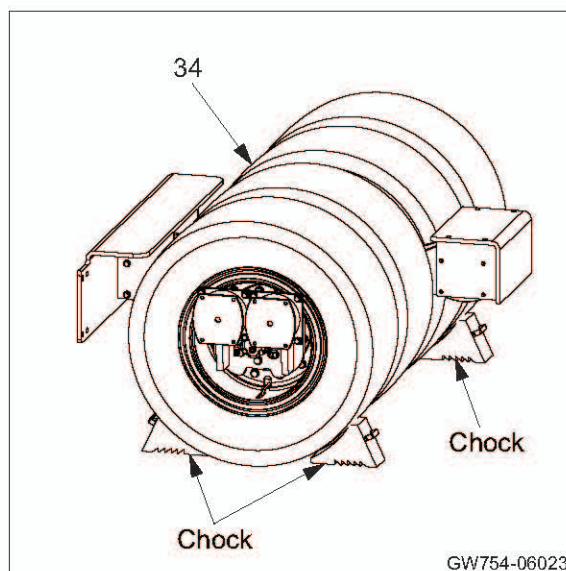

3-1-2. Installation of rear wheel ASSY

- 1) Install rear wheel ASSY in reverse order in which it was removed.
 - Tightening torque for bolts where particular care is required when installing rear wheel ASSY.



- (26) Bolts M16×60 : 265 N·m (195lbf·ft)
- (29) Nuts M12 : 108 N·m (80 lbf·ft)
- (31) Bolts M16×50 : 265 N·m (195lbf·ft)
- (33) Bolts M16×40 : 265 N·m (195lbf·ft)

- 2) Upon installing rear wheel ASSY, pay particular attention to items mentioned below.
 - Fill hydraulic oil tank to specified level to make up for any oil leakage.
 - Start engine and circulate oil through piping. Then check oil level again, ensuring that oil is at specified level.

(NOTICE)

- **If the engine is run at high speed or the cylinder is operated to full stroke when the engine is started for the first time after the work is completed, the piston packing or other items may be damaged by air entering into the cylinder.**

3-2. Rear Wheel ASSY

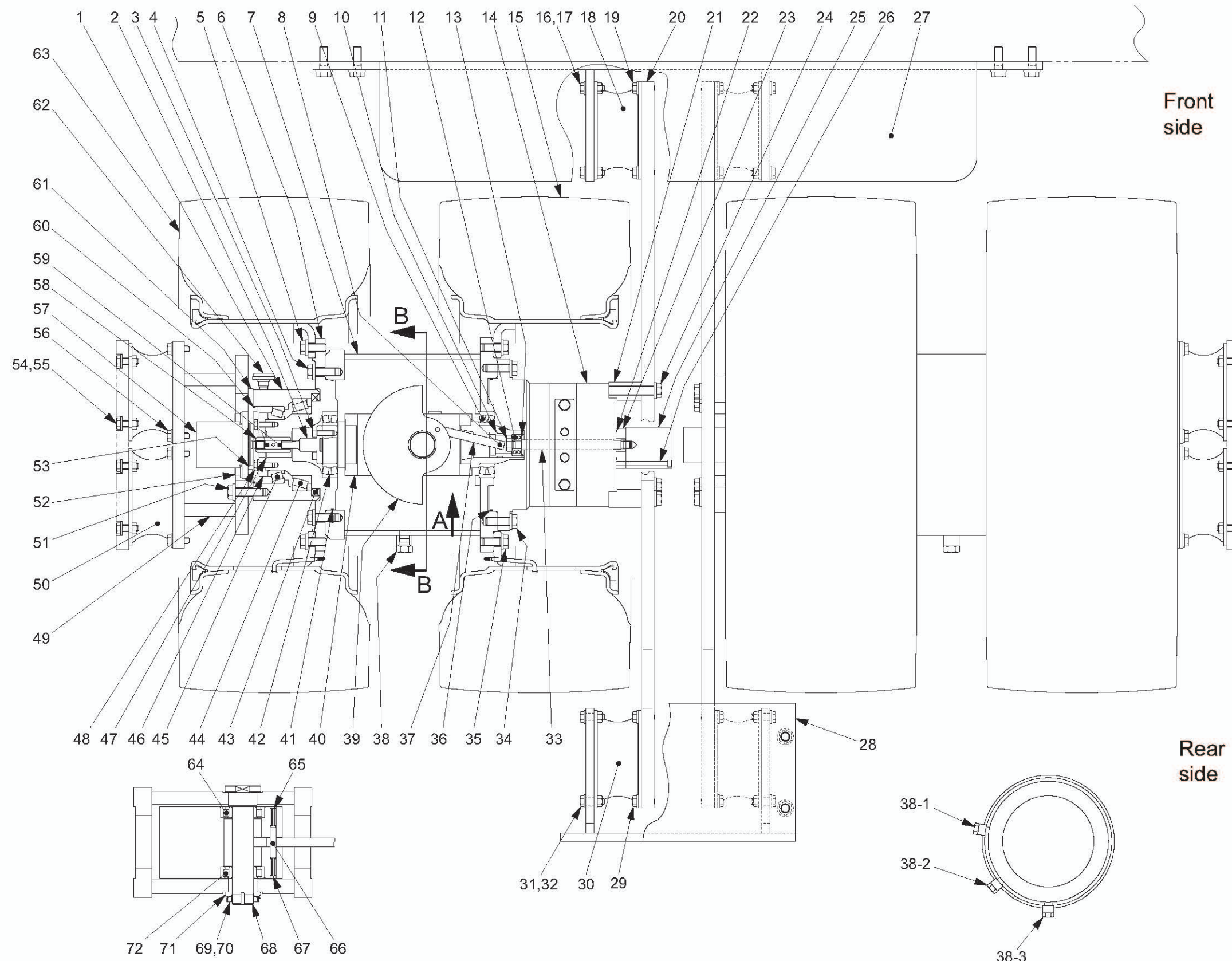

- | | | | |
|-------------------------|-------------|-----------------------|----------|
| (1) Housing | (51) Bolt | : M16×60 | |
| (2) Shaft | (52) Bolt | : M10×25 | |
| (3) Bolt | (53) O-ring | | |
| | | : 3/8-16UNC×1 1/4 in. | |
| (4) Bolt | : M16×45 | (54) Bolt | : M12×40 |
| (5) Bolt | : M16×40 | (55) Nut | : M12 |
| (6) Axle | | (56) Bolt | : M12×35 |
| (7) Case | | (57) Vibrator motor | |
| (8) Pin | | (58) Sleeve | |
| (9) Vibrator bearing | | (59) Spring pin | |
| (10) Guide | | (60) O-ring | |
| (11) Nut | : M14 | (61) Cover | |
| (12) Bearing | | (62) Breather | |
| (13) Retaining ring | | (63) Tire ASSY | |
| (14) Propulsion motor | | (64) Roller bearing | |
| (15) Tire ASSY | | (65) Spring pin | |
| (16) Bolt | : M12×40 | (66) Pin | |
| (17) Nut | : M12 | (67) Spring pin | |
| (18) Damper | | (68) Shaft | |
| (19) Bolt | : M12×35 | (69) Bearing washer | |
| (20) Plate | | (70) Bearing nut | |
| (21) Spacer | | (71) Collar | |
| (22) O-ring | | (72) Roller bearing | |
| (23) Adapter | | | |
| (24) Bolt | : M16×180 | | |
| (25) Amplitude cylinder | | | |
| (26) Bolt | : M 8×110 | | |
| (27) Bracket | | | |
| (28) Bracket | | | |
| (29) Bolt | : M12× 35 | | |
| (30) Damper | | | |
| (31) Bolt | : M12× 35 | | |
| (32) Nut | : M12 | | |
| (33) Rod | | | |
| (34) Bolt | : M16× 50 | | |
| (35) Bolt | : M16× 40 | | |
| (36) O-ring | | | |
| (37) Arm | | | |
| (38) Plug | | | |
| (39) Weight | | | |
| (40) Shaft | | | |
| (41) O-ring | | | |
| (42) Vibrator bearing | | | |
| (43) Oil seal | | | |
| (44) Roller bearing | | | |
| (45) Roller bearing | | | |
| (46) Cover | | | |
| (47) Shim | | | |
| (48) Bolt | : M10×30 | | |
| (49) Plate | | | |
| (50) Damper | | | |

VIEW A

SECTION B-B

0539-27801-0-11177-A

3-3. Disassembly and Reassembly of Rear Wheel

- Lead line numbers shown in the illustrations for the following rear wheel disassembly and reassembly procedures are constant with part numbers of rear wheel ASSY shown on page 6-043.

3-3-1. Disassembly of rear wheel

- 1) Remove plug (38-1) and drain plug (38-3).
 - Drain gear oil.
 - Quantity of gear oil : 2.5 L (0.66 gal.)
 - Install plug (38-1) and drain plug (38-3) to case (7).

(NOTICE)

- Use same procedure to drain gear oil from (L) and (R) rear wheel assemblies.

WARNING

When lifting the bracket, use an appropriate hoist of sufficient strength. Confirm that the surrounding area is safe, and work in a natural, unstrained posture.

- 2) Lift bracket (28).
 - Remove bolts (31) and nuts (32).
 - Remove bracket.

 (28) Bracket : 45 kg (99 lbs.)

- 3) Lift bracket (27).
 - Remove bolts (16) and nuts (17).
 - Remove bracket.

 (27) Bracket : 115 kg (254 lbs.)

(NOTICE)

- After removing brackets, disassemble (L) and (R) rear wheel assemblies separately in same procedure.

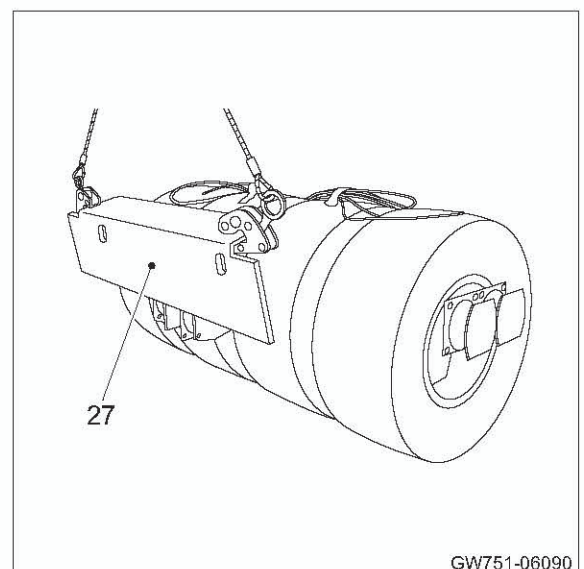
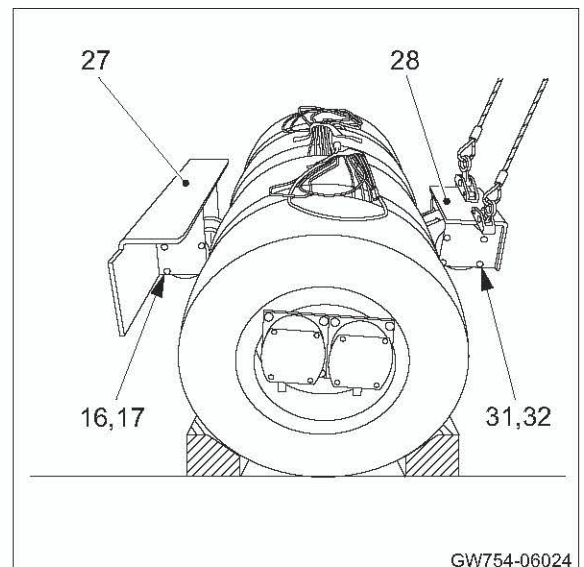
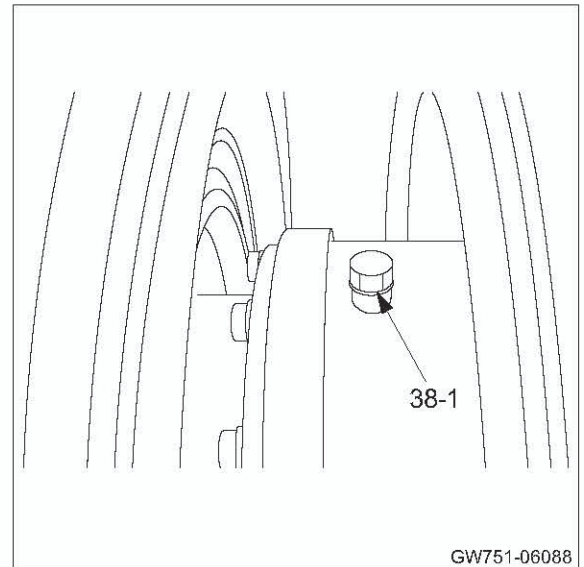

- 4) Remove bolts (19) and (29).
- Remove dampers (18) and (30).

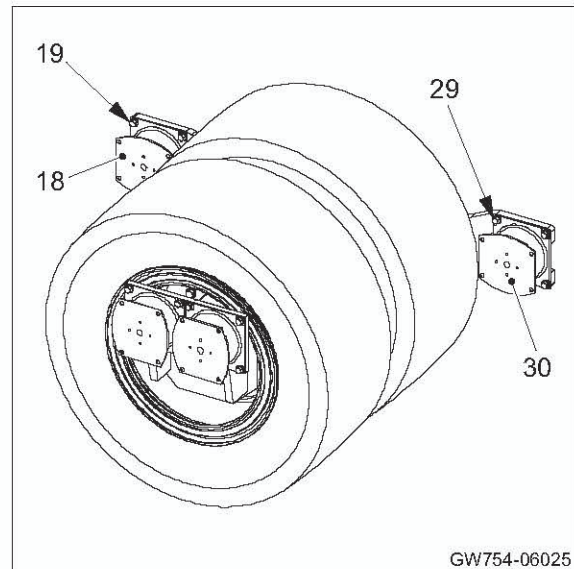

- 5) Disconnect hydraulic hose from amplitude cylinder (25).

(NOTICE)

- Plug both ends of the disconnected hoses or implement other actions to prevent entry of foreign matter.
- Remove switch harness from amplitude cylinder.

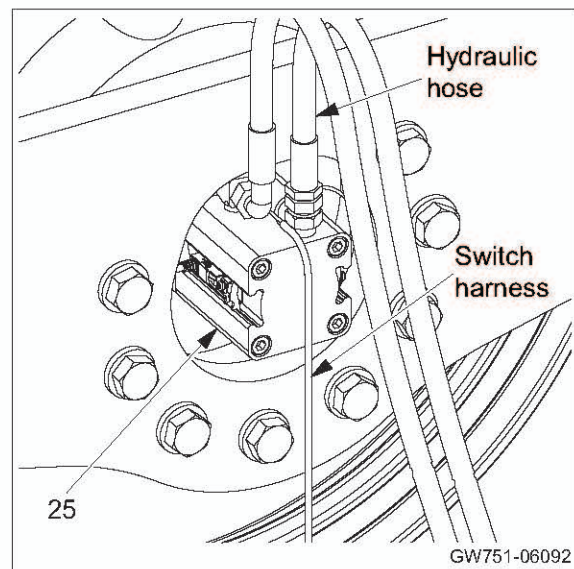

- 6) Lift plate (20).
- Remove bolts (24).
 - Remove plate.

 (20) Plate : 55 kg (121 lbs.)

(NOTICE)

- Take care not to damage the hydraulic hose during removal.

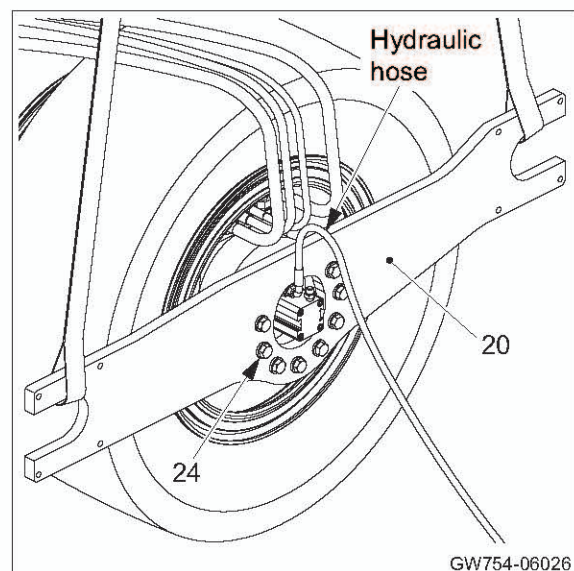

7) Disconnect hydraulic hoses from propulsion motor (14).

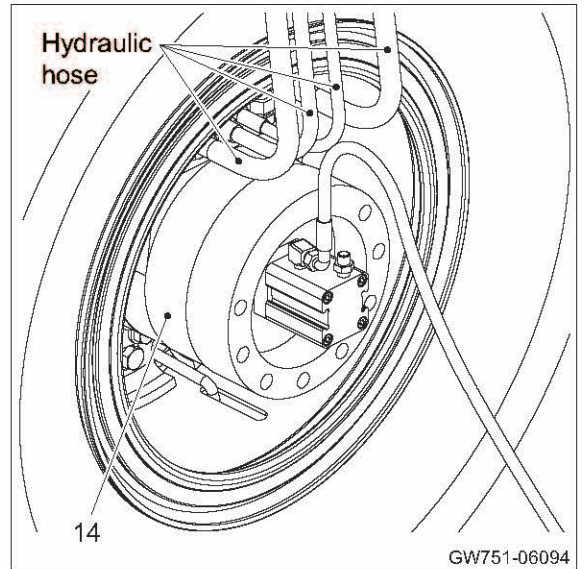

8) Disconnect hydraulic hose from amplitude cylinder (25).

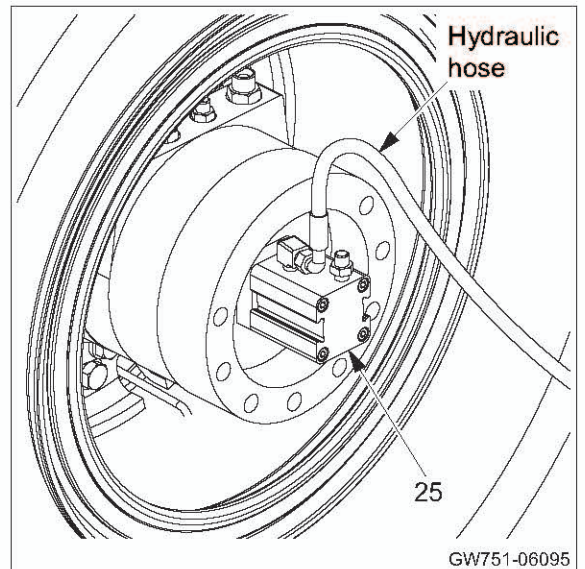

9) Remove spacer (21).

 (21) Spacer : 15 kg (33 lbs.)

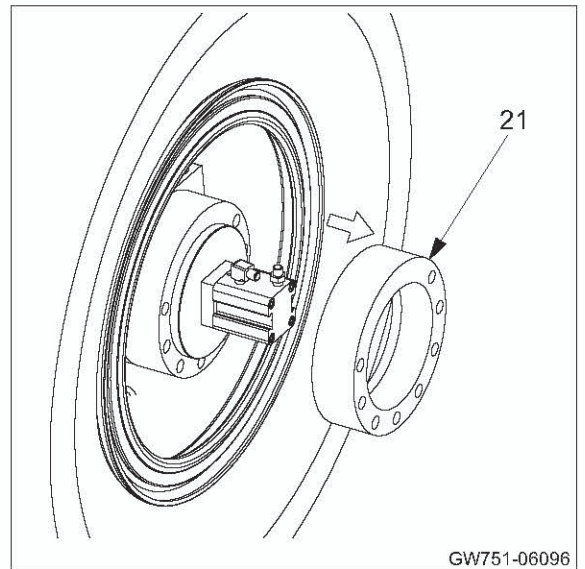

10) Remove bolts (26).

- Pull out cylinder rod and rod (33).
- Using wrenches, remove cylinder rod from rod.
- Remove amplitude cylinder (25) and adapter (23).

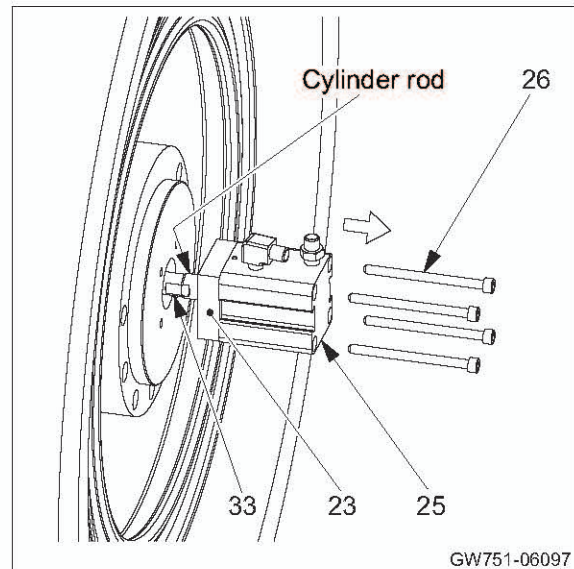

⚠ WARNING

Carry out the work in an unstrained posture using a work stool or the like.

11) Stand wheel SUBASSY with vibrator motor (57) side facing up.

 Wheel SUBASSY : 650 kg (1,433 lbs.)

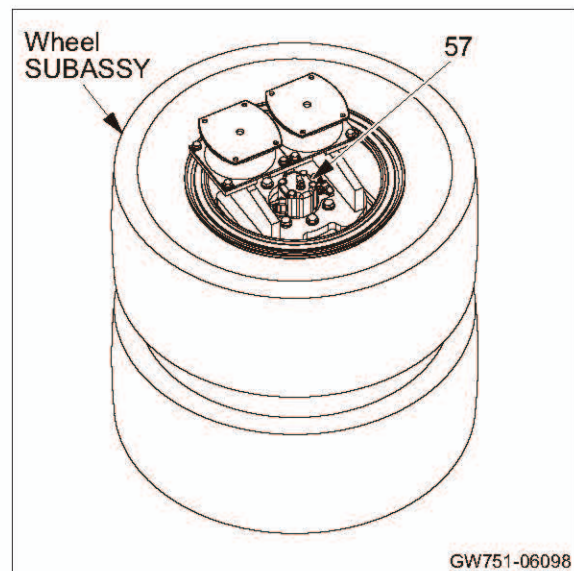

12) Remove bolts (56).

- Remove dampers (50).

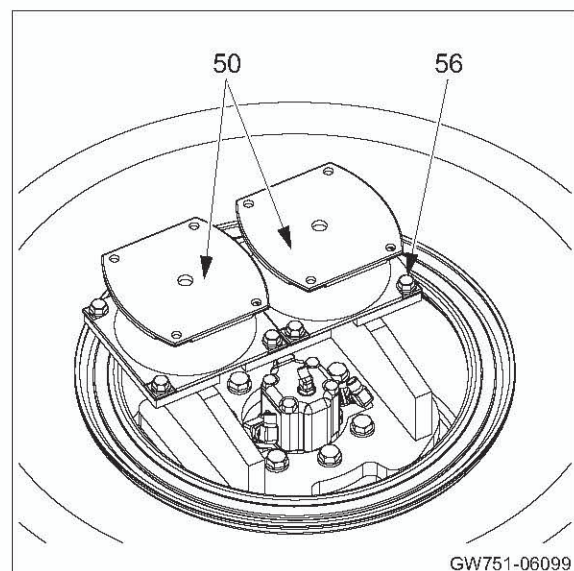

13) Remove adapters.

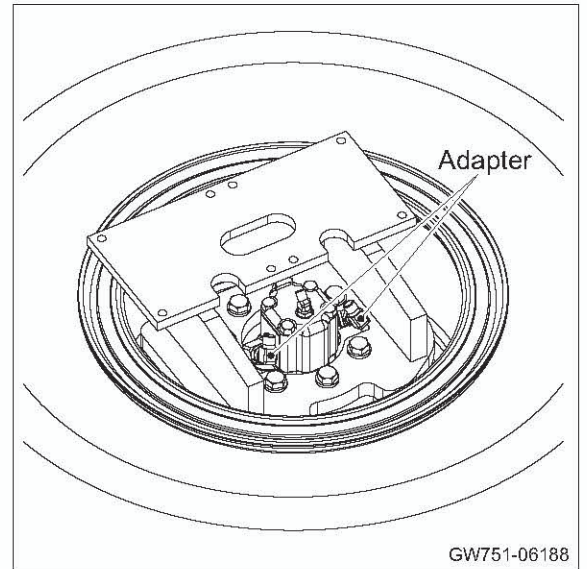

⚠ WARNING

When installing lifting bolts, screw in the threads fully before using.

14) Install lifting bolts (M12) to plate (49).
 • Remove bolts (51).

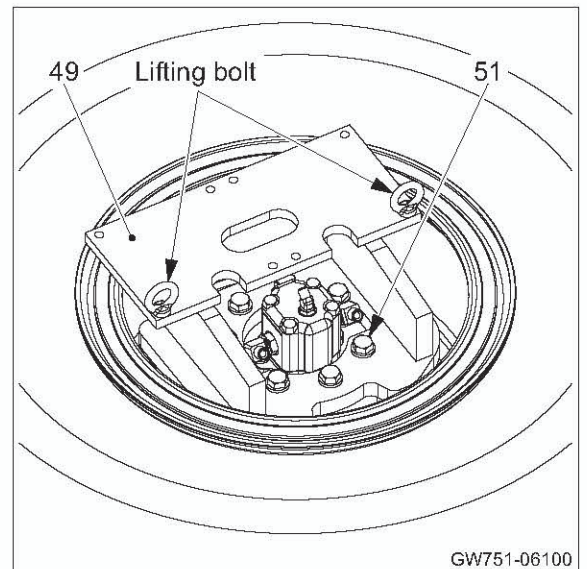

15) Remove plate (49).

 (49) Plate : 35 kg (77 lbs.)

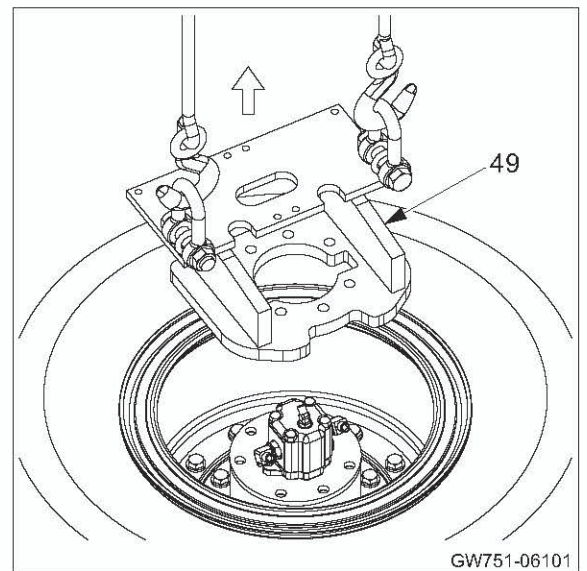

16) Remove vibrator motor SUBASSY.

 Vibrator motor SUBASSY : 10 kg (22 lbs.)

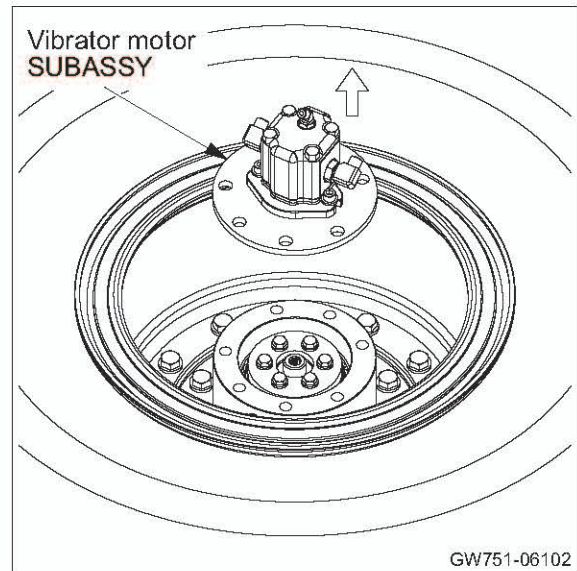

17) Remove breather (62).

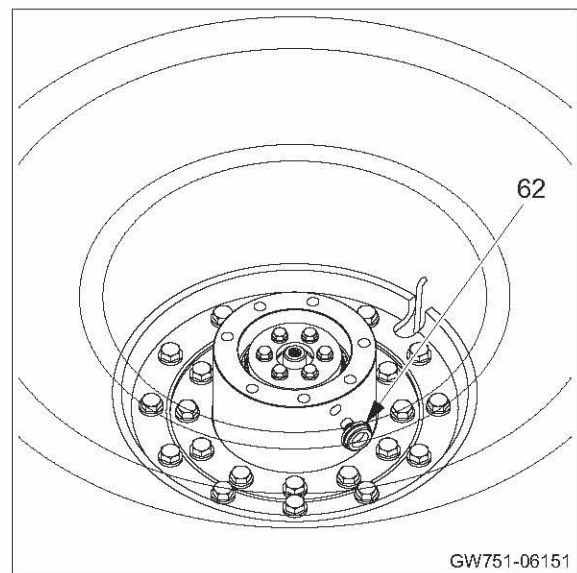

18) Remove sleeve (58).

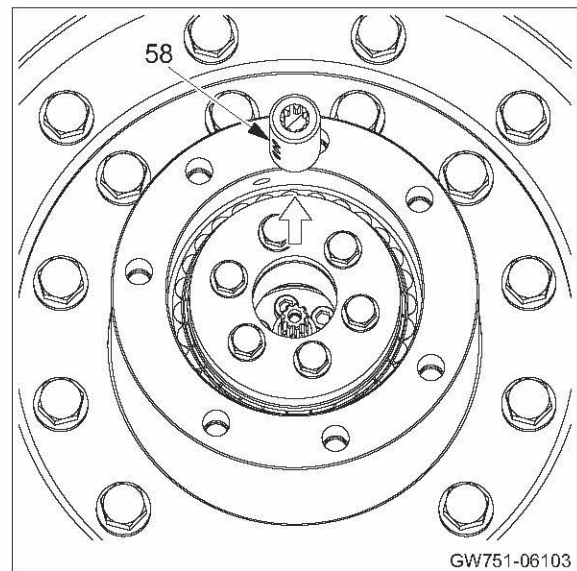

19) Remove bolts (5).

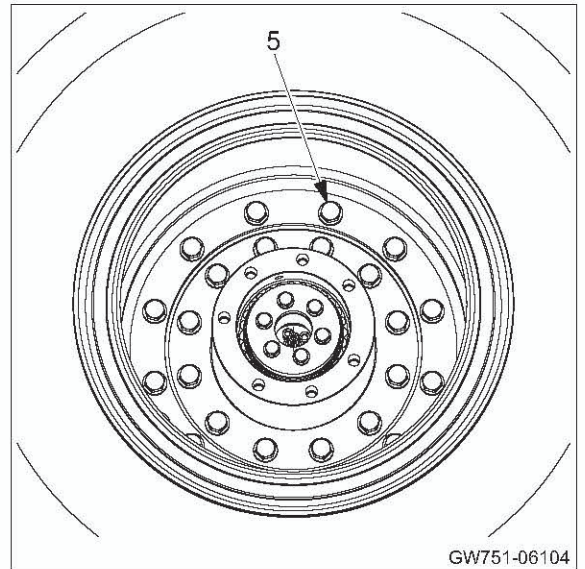

20) Remove tire ASSY (63).

 (63) Tire ASSY : 170 kg (375 lbs.)

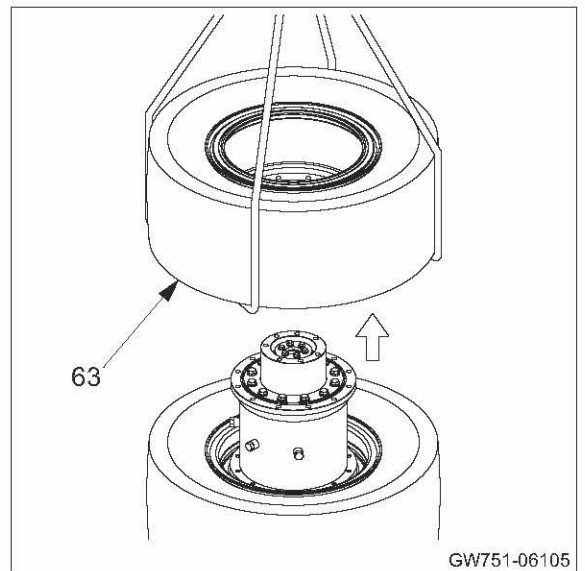

21) Install lifting bolts (M16) to axle SUBASSY.

- Remove bolts (4).

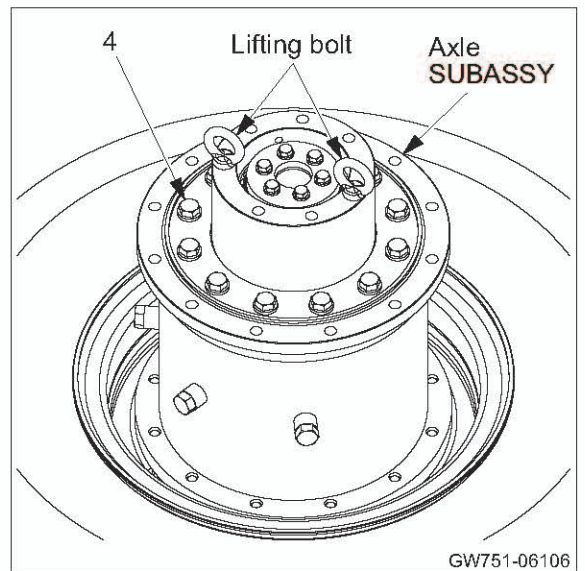

22) Remove axle SUBASSY.

 Axle SUBASSY : 55 kg (121 lbs.)

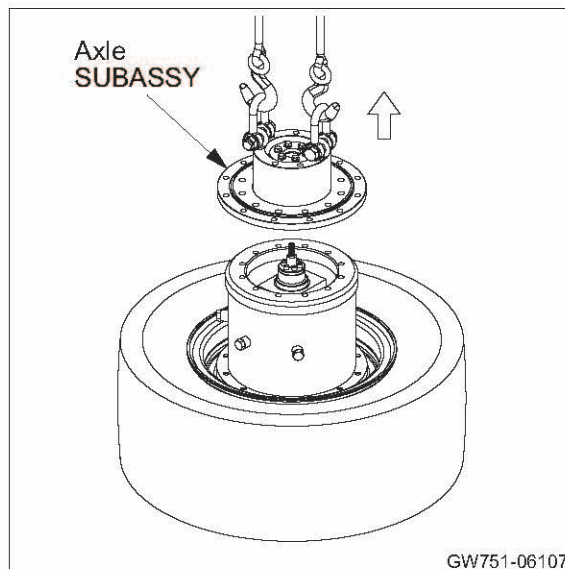

23) Remove bolts (48).

- Remove cover (46).
- Remove shim (47).

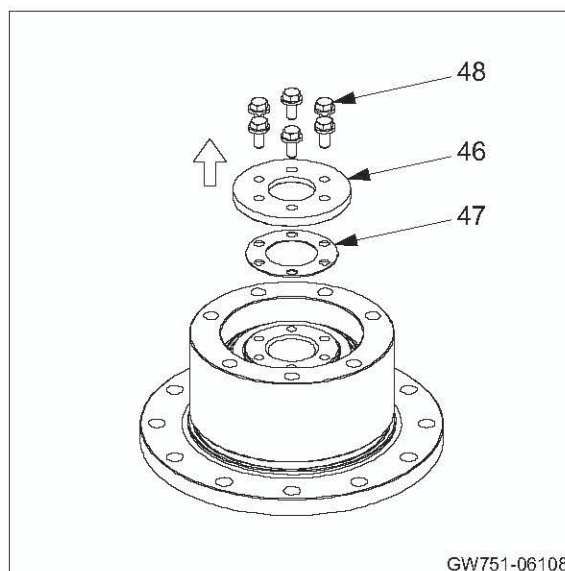

24) Put a piece of wooden board on end of axle (6).

- Set a puller on housing (1).
- Remove housing SUBASSY with roller bearing from axle SUBASSY.

 Housing SUBASSY : 20 kg (44 lbs.)

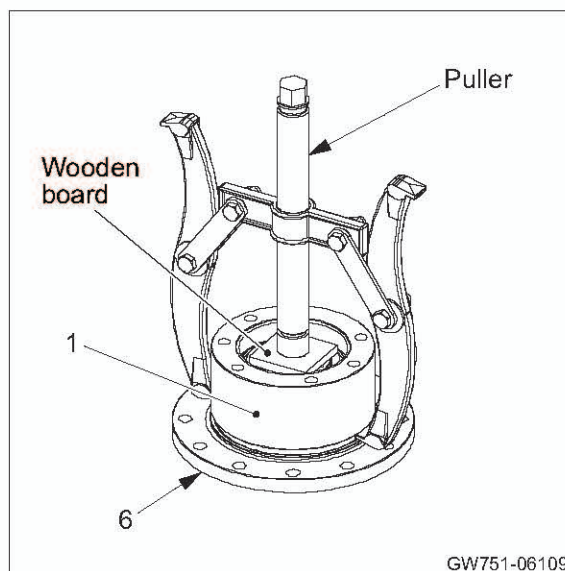

25) Install lifting bolt (M8) to shaft SUBASSY.

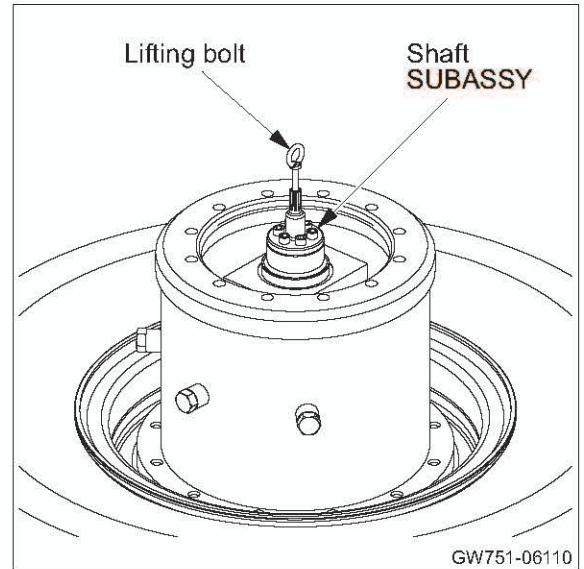

26) Remove shaft SUBASSY.

 Shaft SUBASSY : 45 kg (99 lbs.)

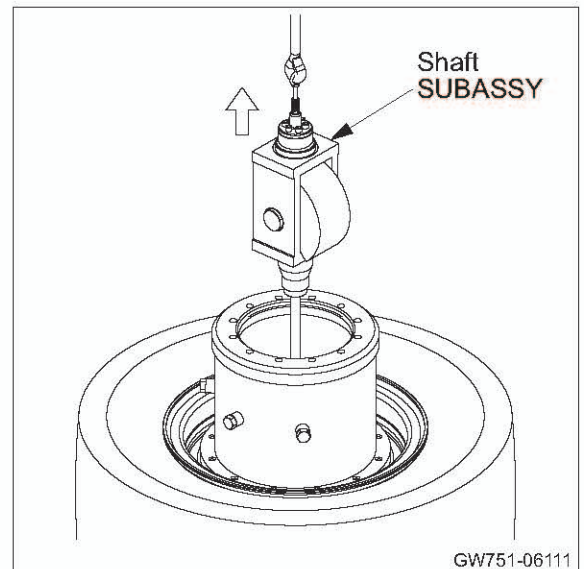

⚠ WARNING

Be careful because reversing the wheel involves risk. Confirm that the surrounding area is safe, and work in a natural, unstrained posture.

27) Reverse wheel SUBASSY.

 Wheel SUBASSY : 320 kg (705 lbs.)

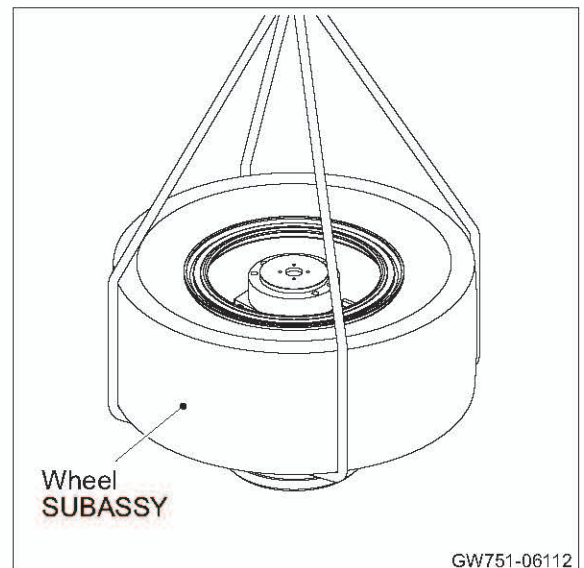

28) Install lifting bolts (M16) to propulsion motor (14).

- Remove bolts (34).

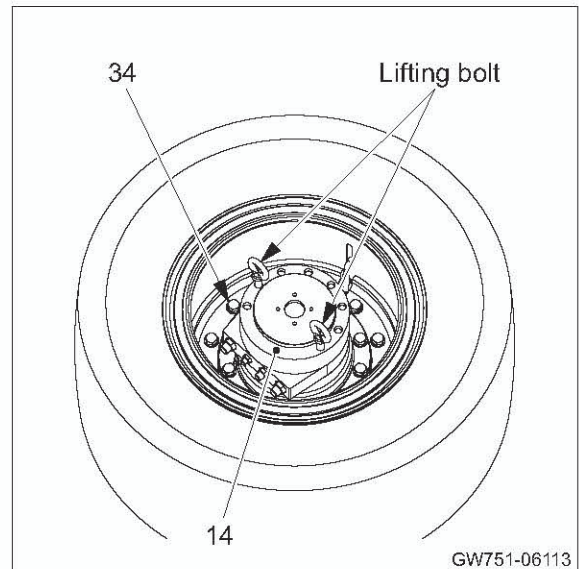

29) Remove propulsion motor (14).

 (14) Propulsion motor : 80 kg (176 lbs.)

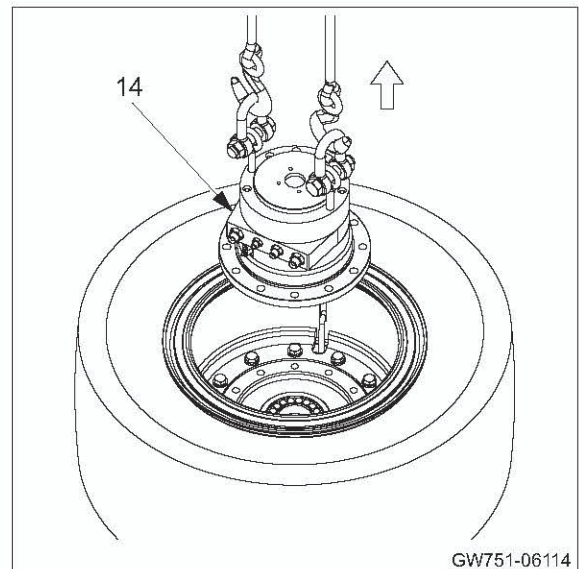

30) Remove bolts (35).

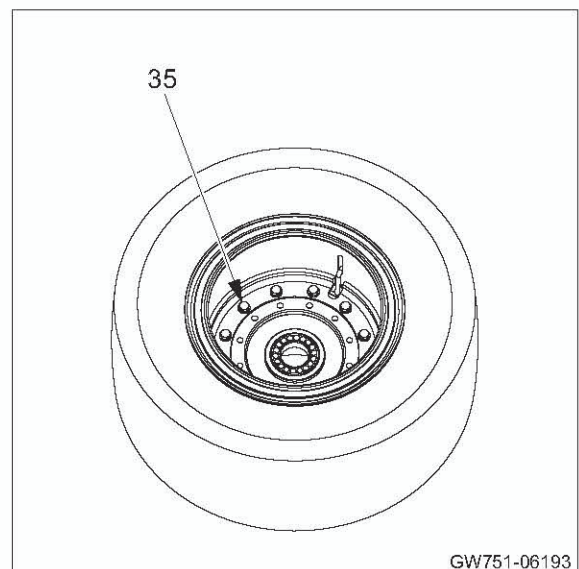

31) Remove tire ASSY (15).

 (15) Tire ASSY : 170 kg (375 lbs.)

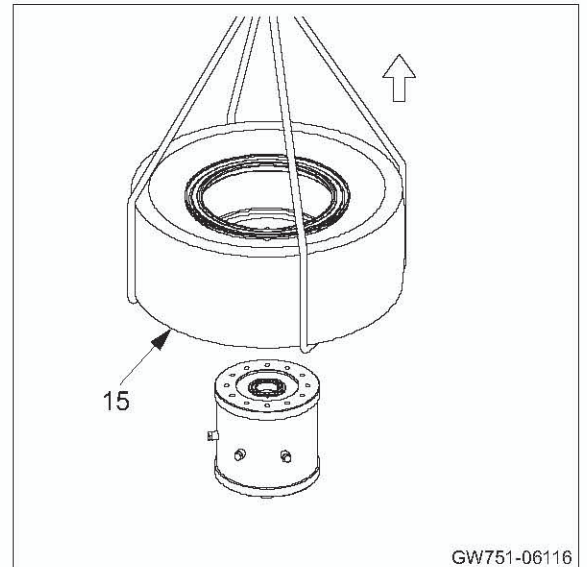

3-3-2. Reassembly of rear wheel

- Before reassembling, clean disassembled parts well and check that there is no abnormality.

- 1) Apply a coat of gear oil to case (7) at where bearing will be press-fitted.
 - Install vibrator bearing (9) to case.

(NOTICE)

- **Take care not to damage the bearing when installing it.**
- Apply grease to O-rings for plugs (38).
- Install plugs to case.

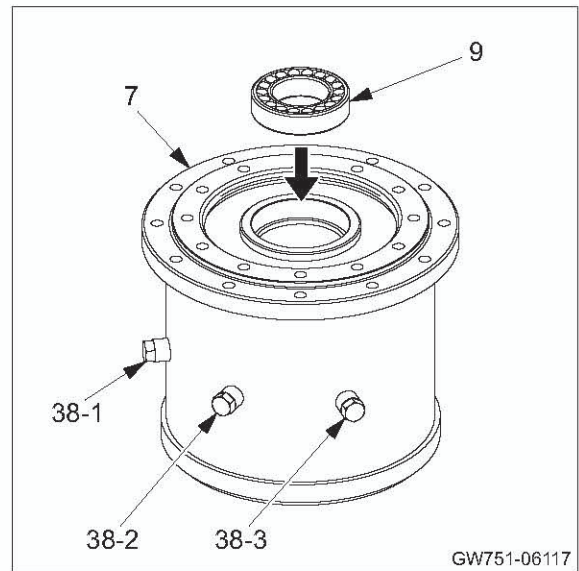

- 2) Lower tire ASSY (15) on mounting surface of case (7).

 (15) Tire ASSY : 170 kg (375 lbs.)

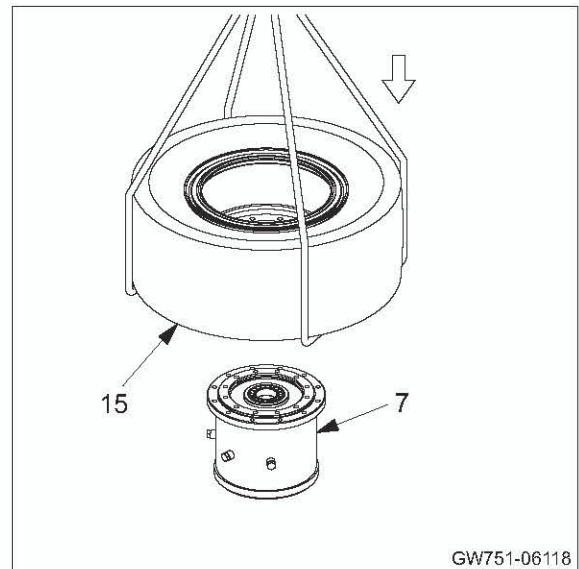

- 3) Secure tire ASSY (15) to case (7) with twelve bolts (35) and washers.

 (35) Bolts M16×40 : 265 N·m (195 lbf·ft)

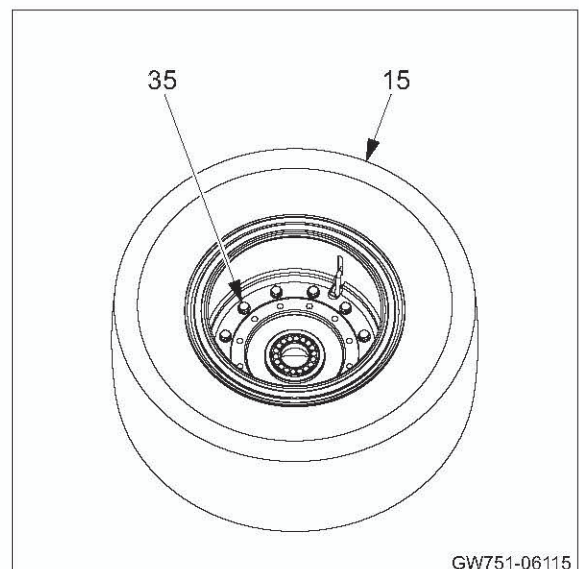

⚠ WARNING

When installing lifting bolts, screw in the threads fully before using.

- 4) Apply grease to O-rings for adapters.
 - Install adapters to propulsion motor (14).
 - Install lifting bolts (M16) to propulsion motor.

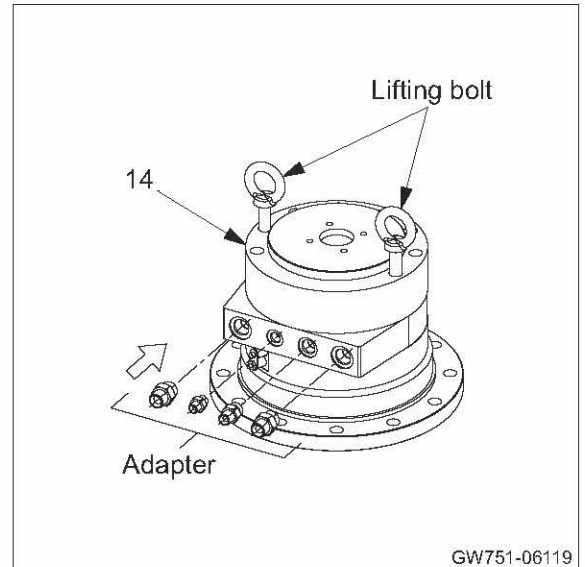

- 5) Lift propulsion motor (14).

 (14) Propulsion motor : 80 kg (176 lbs.)

- Apply grease to O-ring (36).
- Install O-ring to propulsion motor.

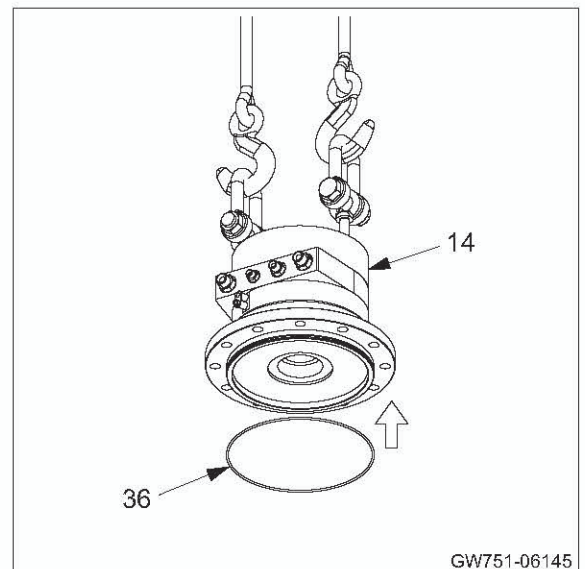

- 6) Lower propulsion motor (14) on mounting surface of case (7).

(NOTICE)

- Take care not to let O-ring to protrude from its groove.

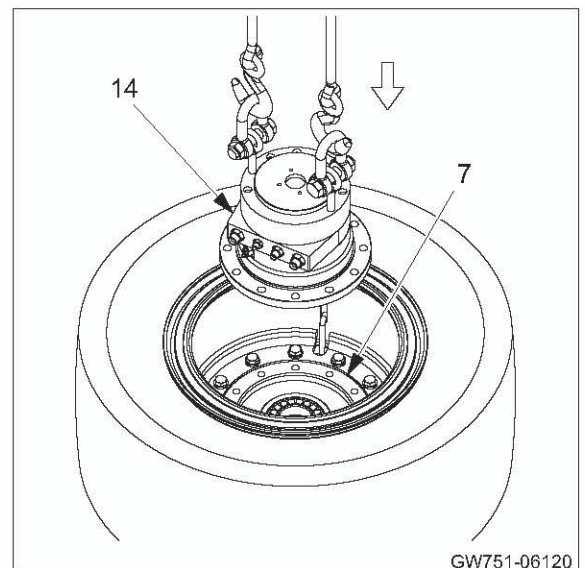

- 7) Secure propulsion motor (14) to case (7) with twelve bolts (34) and washers.



(34) Bolts M16×50 : 265 N·m (195 lbf·ft)

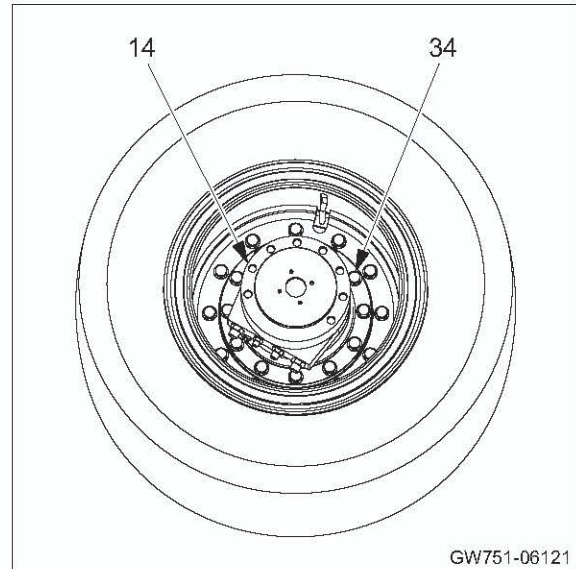

WARNING

Be careful because reversing the wheel involves risk. Confirm that the surrounding area is safe, and work in a natural, unstrained posture.

- 8) Reverse wheel SUBASSY.



Wheel SUBASSY : 320 kg (705 lbs.)

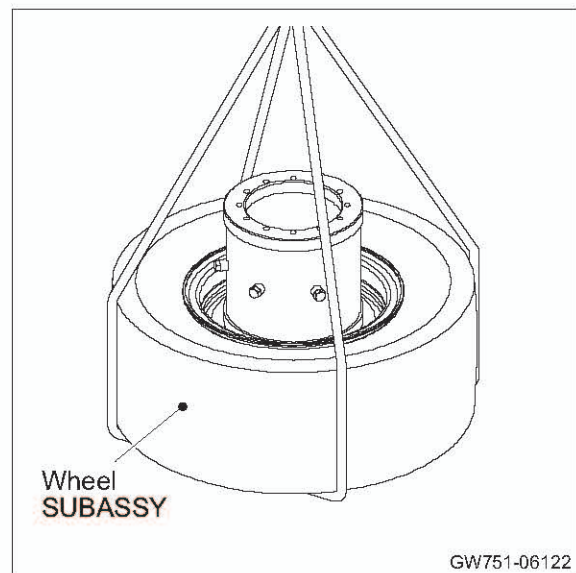

- 9) Reassembly of shaft SUBASSY

- 9-1) Secure shaft (2) to shaft (40) with six bolts (3).



(3) Bolts 3/8-16UNC×1 1/4 in.
: 59 N·m (44 lbf·ft)

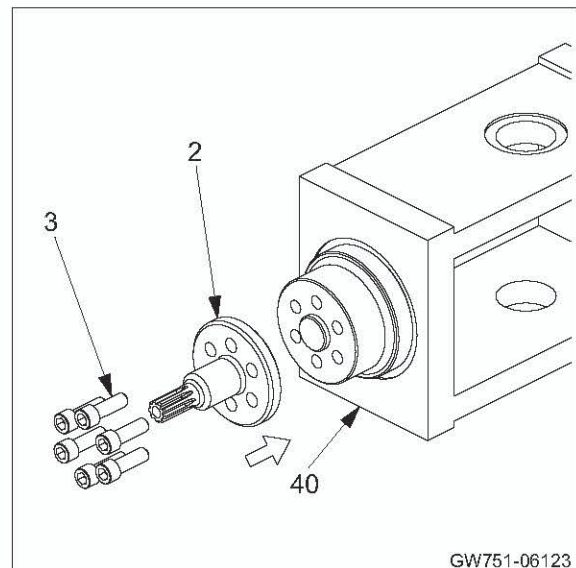

- 9-2) Align pin (8) mounting hole in arm (37) with pin mounting hole in guide (10).
- Install pin to guide.
 - Stake edge of each pin mounting hole at top and bottom of guide at three points.

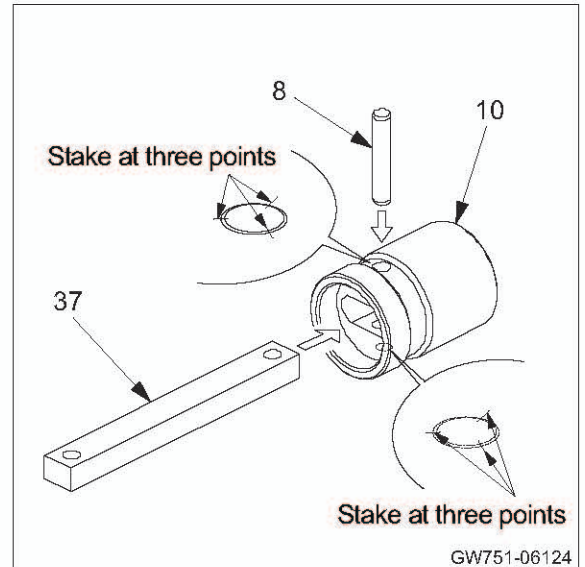

- 9-3) Apply a coat of gear oil to weight (39) at where bearing will be press-fitted.
- Drive roller bearing (64) into weight.

(NOTICE)

- Take care not to damage the bearing when installing it.
- Drive spring pin (65) into weight.

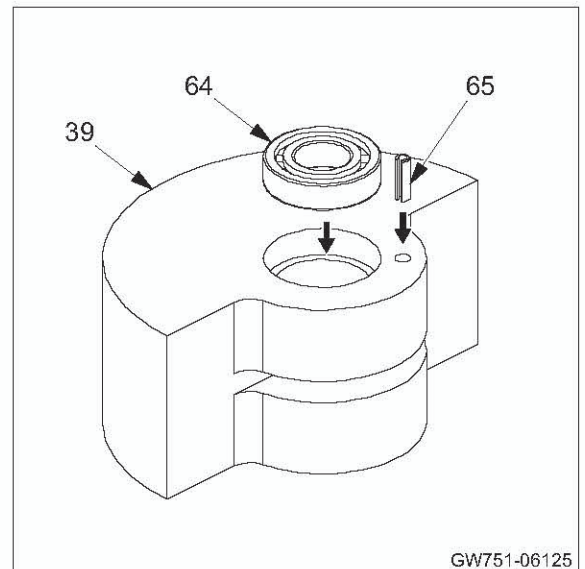

- 9-4) Reverse weight SUBASSY.
- Apply a coat of gear oil to weight (39) at where bearing will be press-fitted.
 - Drive roller bearing (72) into weight.

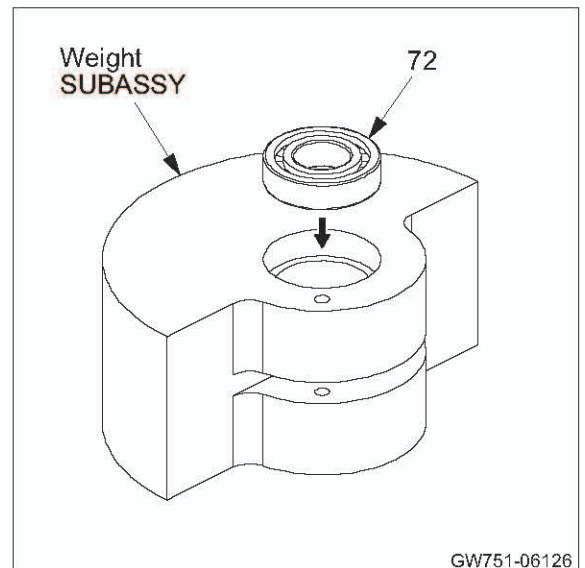

9-5) Align pin (66) mounting hole in arm SUBASSY with pin mounting hole in weight SUBASSY.

- Install pin to weight (39).
- Drive spring pin (67) into weight.

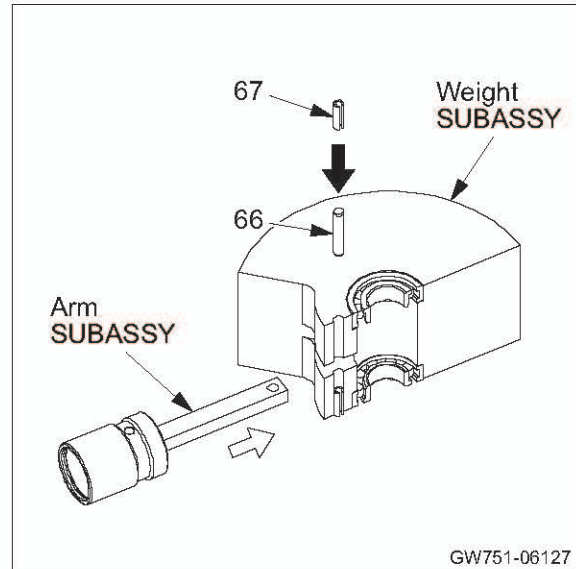

9-6) Apply a coat of gear oil to shaft (40) at where guide (10) will be installed.

- Install weight SUBASSY to shaft SUBASSY.

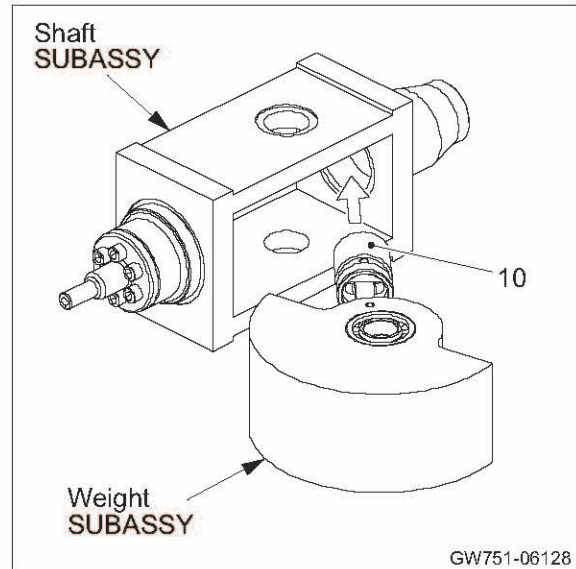

9-7) Install collar (71) to shaft SUBASSY.

- Apply a coat of gear oil to shaft (68).
- Install shaft to shaft SUBASSY with bearing nut (70) and bearing washer (69).

(NOTICE)

- **After installation, make sure that weight SUBASSY moves smoothly.**

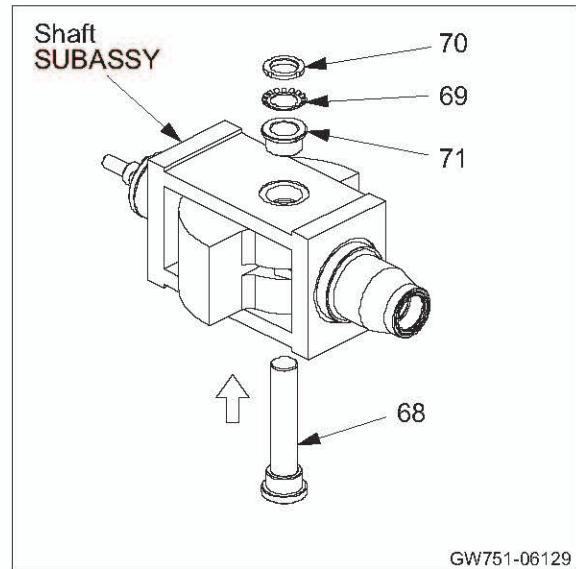

9-8) Apply a coat of gear oil to rod (33) at where bearing will be installed.

- Apply sufficient amount of lithium-based grease to bearing (12).
- Install bearing to rod with nut (11).
- Stake edge of nut at two points.

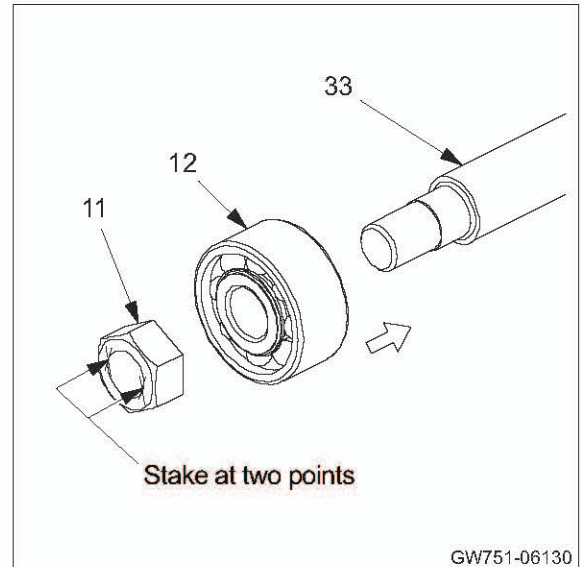

9-9) Apply a coat of gear oil to guide (10) at where bearing will be installed.

- Install rod SUBASSY to shaft SUBASSY.
- Install retaining ring (13) to guide.

(NOTICE)

- **Make sure that the retaining ring is fitted completely in its groove.**

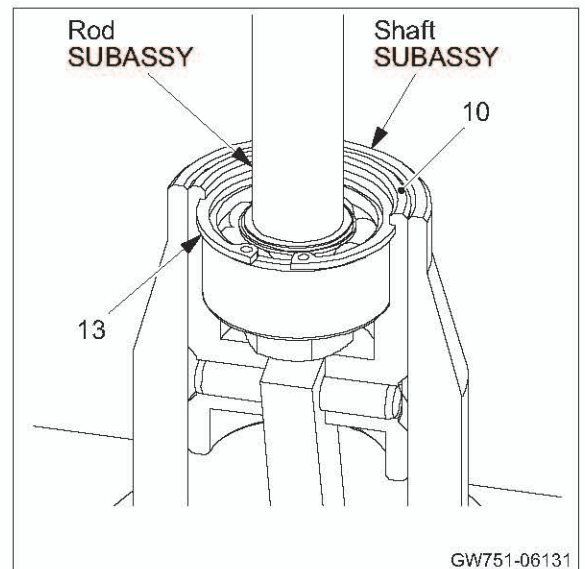

10) Install lifting bolt (M8) to shaft SUBASSY.

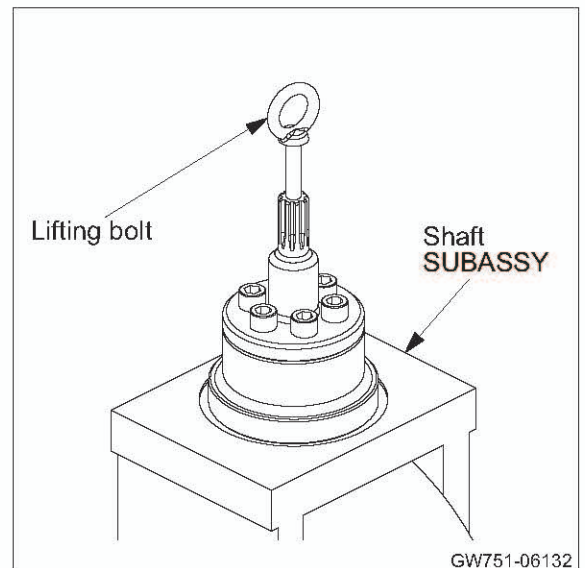

- 11) Apply a coat of gear oil to shaft (40) at where bearing will be installed.
- Install shaft SUBASSY to wheel SUBASSY.

 Shaft SUBASSY : 45 kg (99 lbs.)

(NOTICE)

- Insert shaft SUBASSY into vibrator bearing (9) while taking care not to tilt vibrator bearing inner race.
- Take care not to damage threaded portion of the rod (33) when installing parts.

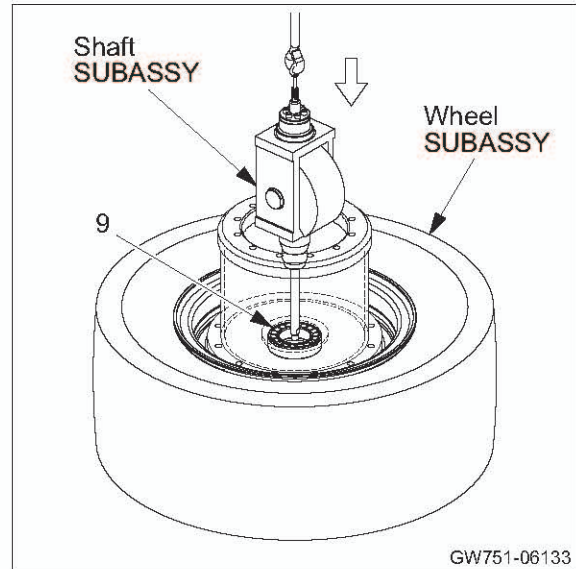

GW751-06133

12) Reassembly of axle SUBASSY

- 12-1) Apply a coat of gear oil to axle (6) at where bearing will be press-fitted.
- Drive vibrator bearing (42) into axle.

(NOTICE)

- Take care not to damage the bearing when installing it.

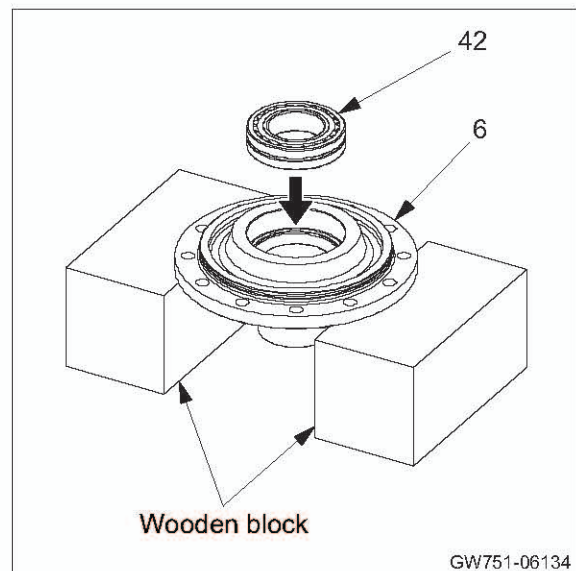

GW751-06134

12-2) Reverse axle SUBASSY.

 Axle SUBASSY : 30 kg (66 lbs.)

- Apply a coat of gear oil to axle (6) at where bearing will be press-fitted.
- Drive roller bearing (44) inner race into axle.

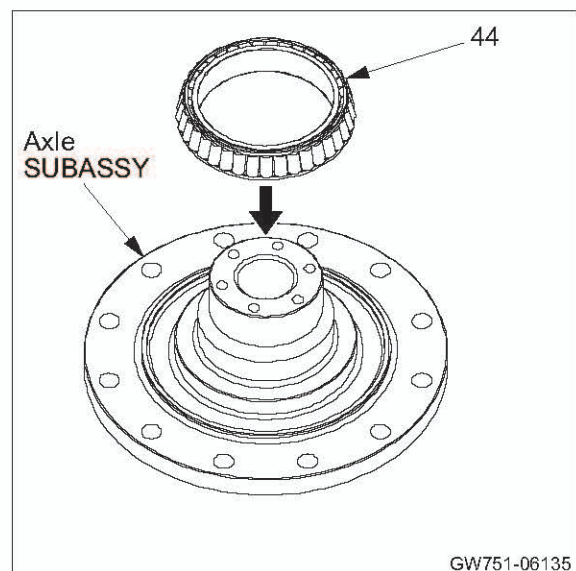

GW751-06135

- 12-3) Apply a coat of gear oil to housing (1) at where bearing outer races will be press-fitted.
- Drive roller bearings (44) and (45) outer races into housing.
 - Apply liquid packing to periphery of oil seal (43).
 - Drive oil seal into housing.
 - Apply grease to lip of oil seal.

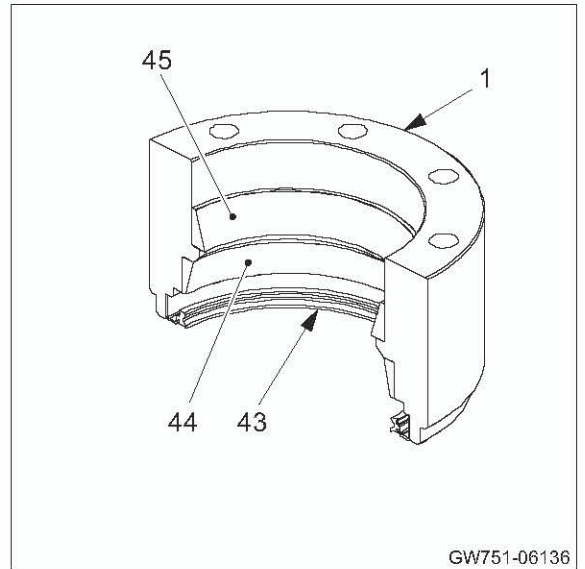

- 12-4) Apply sufficient amount of lithium-based grease to rollers of roller bearing (44) inner race.
- Install housing SUBASSY to axle SUBASSY.

 Housing SUBASSY : 20 kg (44 lbs.)

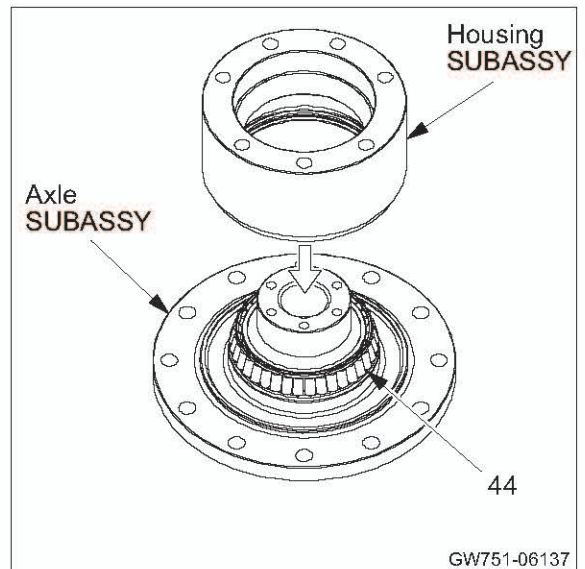

- 12-5) Apply a coat of gear oil to axle (6) at where bearing will be press-fitted.
- Apply sufficient amount of lithium-based grease to rollers of roller bearing (45) inner race.
 - Drive in roller bearing inner race until rollers come in contact with outer race.

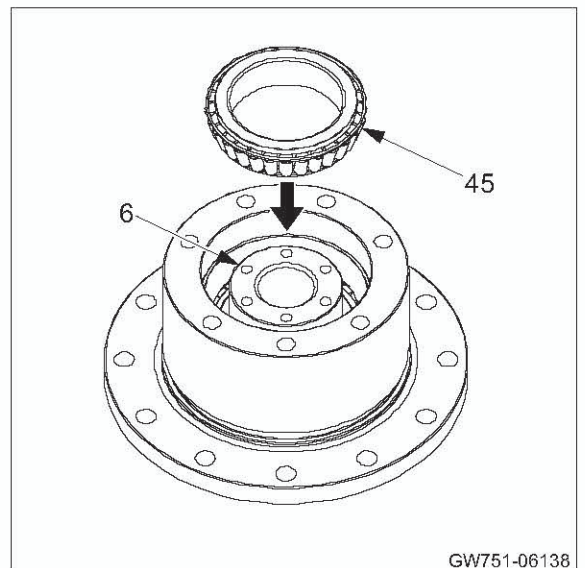

12-6) Preload adjustment of roller bearing

① Install cover (46) to axle (6) with six bolts (48) and washers.

- Tighten bolts to a torque of 29 N·m (21 lbf·ft).
- Give housing (1) two to three turns.
- Tighten bolts to a torque of 29 N·m (21 lbf·ft) again.
- Repeat this work several times until tightening torque of bolts no longer fluctuates.

(NOTICE)

- Tighten the bolts alternately in diagonal directions.

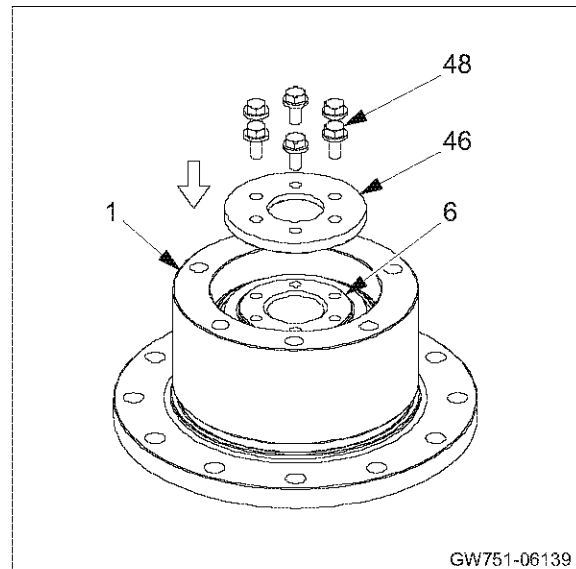
**(NOTICE)**

- Push in the inner race while rotating the bearing. Otherwise, even strongly trying to push the inner race, the bearing rollers will not be pushed up and therefore bearing will not be seated.

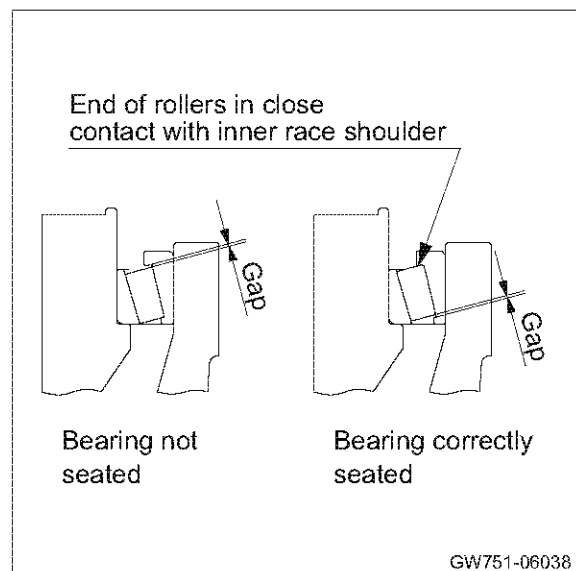

② Remove bolts (48).

- Remove cover (46).

(NOTICE)

- Do not turn the housing (1) after the cover is removed.

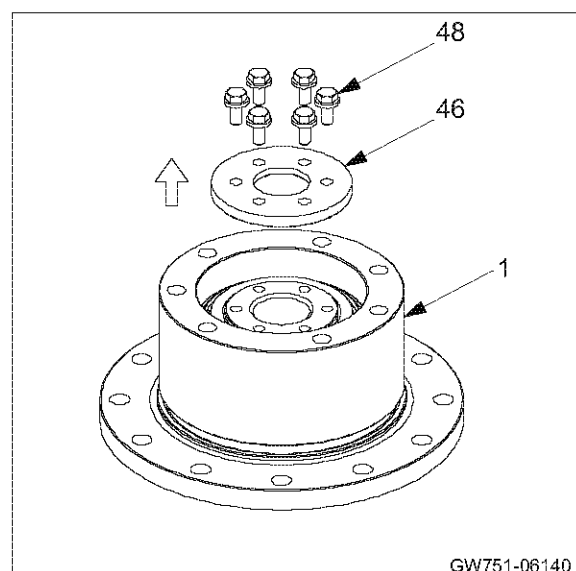

③ Measure dimension "a" between axle (6) end face and roller bearing (45) at three points, and calculate average of measurements.

★ Reference dimension a: 4.6 to 5.1 mm (0.18 to 0.20 in.)

• Measure dimension "b" inside of cover (46).

★ Preload adjusting shim thickness = $(b-a) - 0.1 \text{ mm (0.004 in.)}$

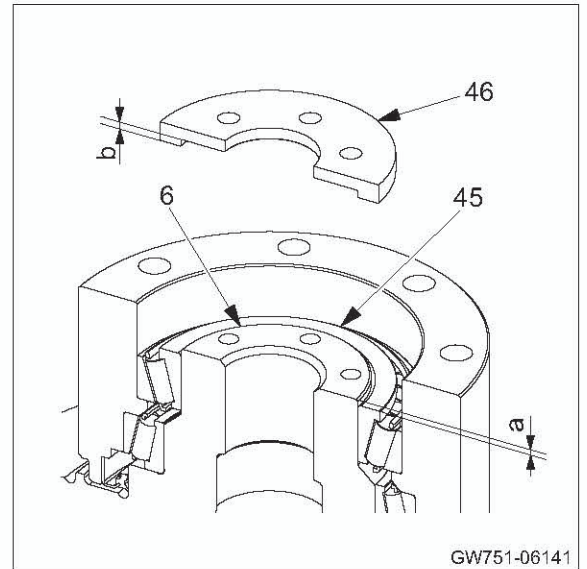

④ Install shim (47) of preload adjusting shim thickness = $(b-a) - 0.1 \text{ mm (0.004 in.)}$.

• Secure cover (46) to axle (6) with six bolts (48) and washers.

 (48) Bolts M10×30 : 59 N·m (44 lbf·ft)

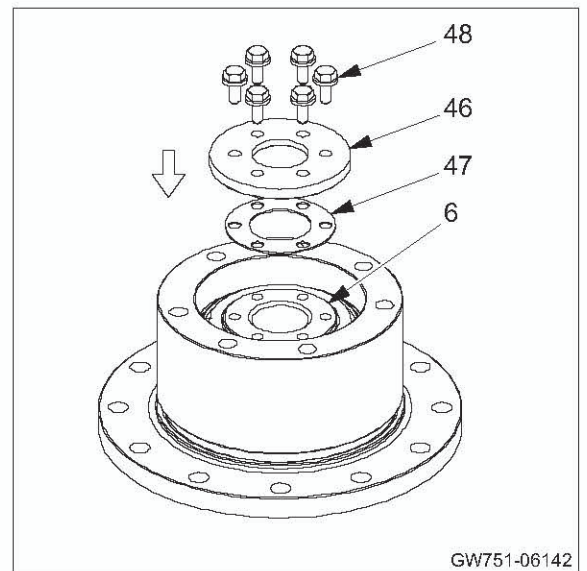

12-7) Install lifting bolts (M16) to axle SUBASSY.

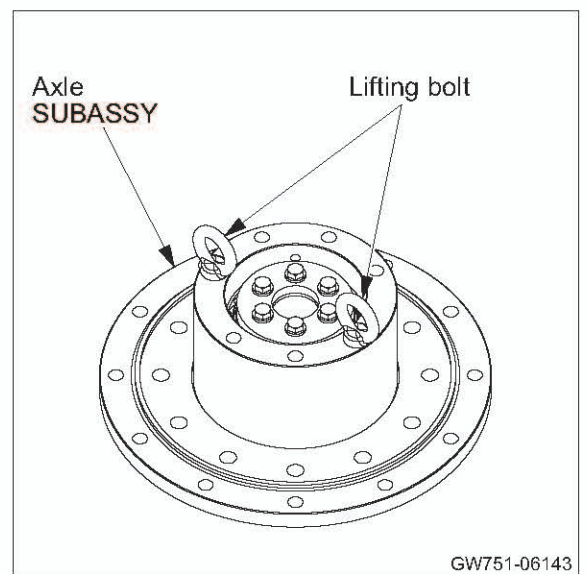

12-8) Lift axle SUBASSY.

 Axle SUBASSY : 55 kg (121 lbs.)

- Apply grease to O-ring (41).
- Install O-ring (41).

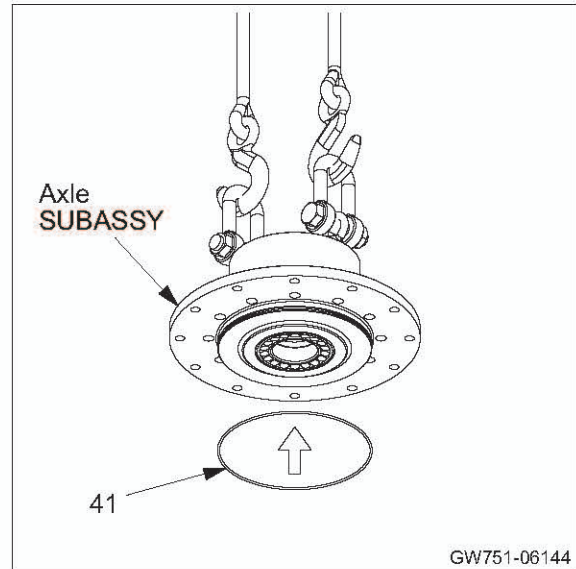

12-9) Lower axle SUBASSY on mounting surface of case (7).

(NOTICE)

- Support the shaft SUBASSY with a pipe or the like, to prevent tilting of the vibrator bearing inner race during installation.
- Take care not to let O-ring to protrude from its groove.

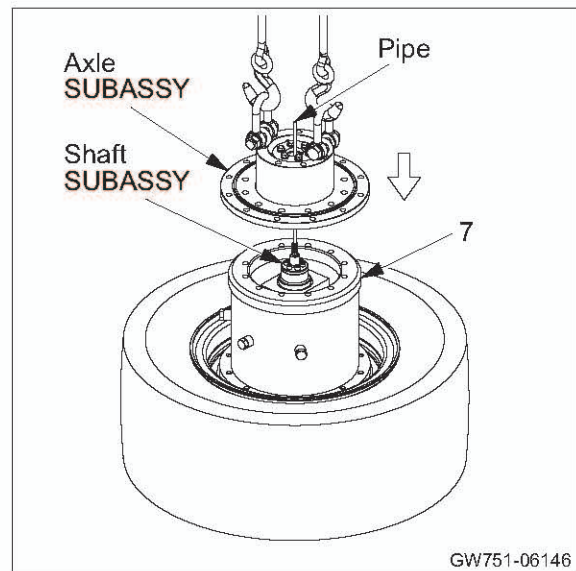

12-10) Secure axle SUBASSY to case (7) with twelve bolts (4) and washers.

 (4) Bolts M16×45 : 265 N·m (195 lbf·ft)

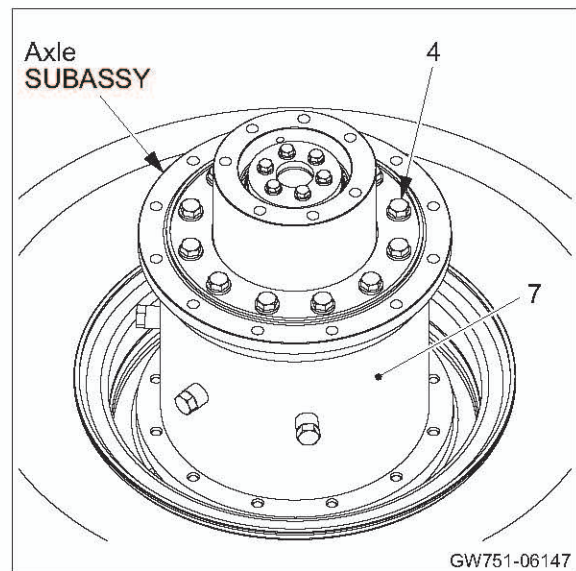

13) Lower tire ASSY (63) on mounting surface of axle (6).

 (63) Tire ASSY : 170 kg (375 lbs.)

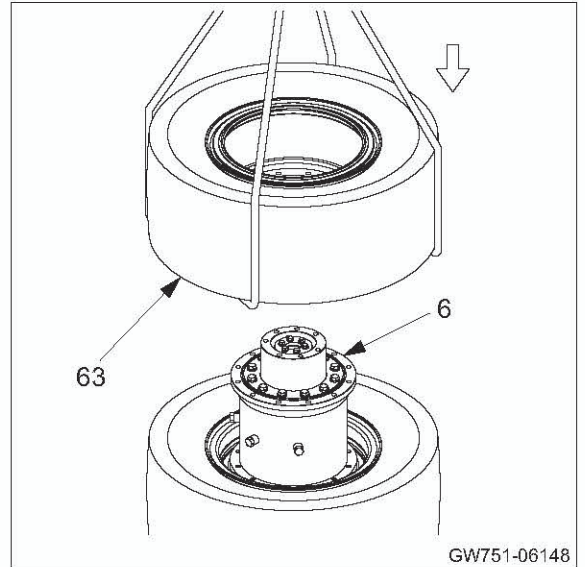

14) Secure tire ASSY (63) to axle (6) with twelve bolts (5) and washers.

 (5) Bolts M16×40 : 265 N·m (195 lbf·ft)

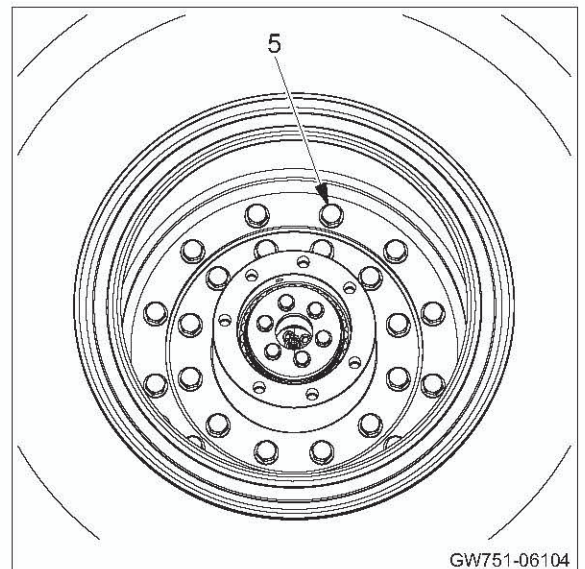

15) Drive two spring pins (59) into sleeve (58).

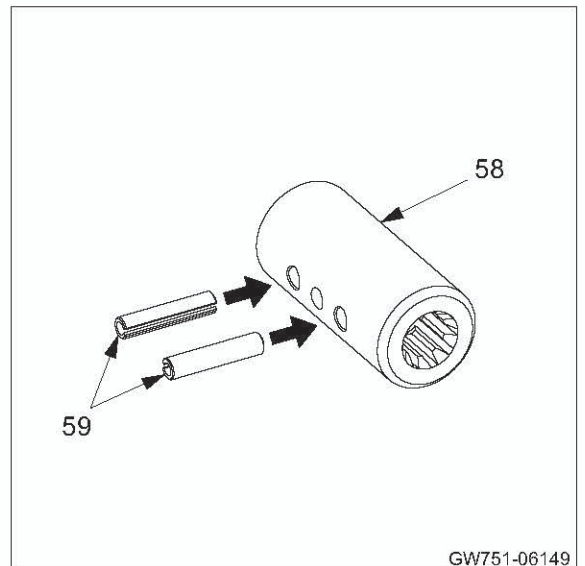

- 16) Apply molybdenum-based grease to splined portion of sleeve (58).
- Fit sleeve to splined portion on shaft (2).

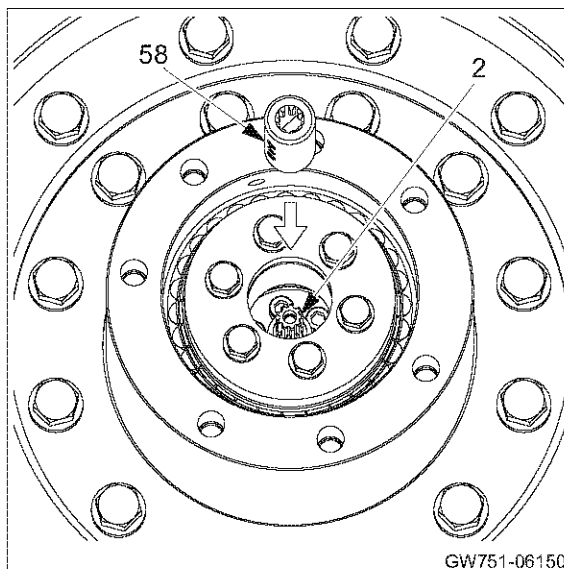

- 17) Wind seal tape around threaded portion of breather (62).
- Install breather to housing (1).

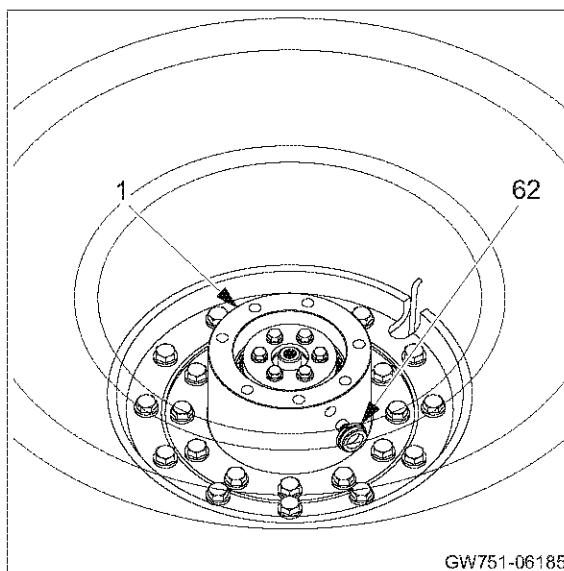

- 18) Apply grease to O-ring (53).
- Install O-ring to vibrator motor (57).

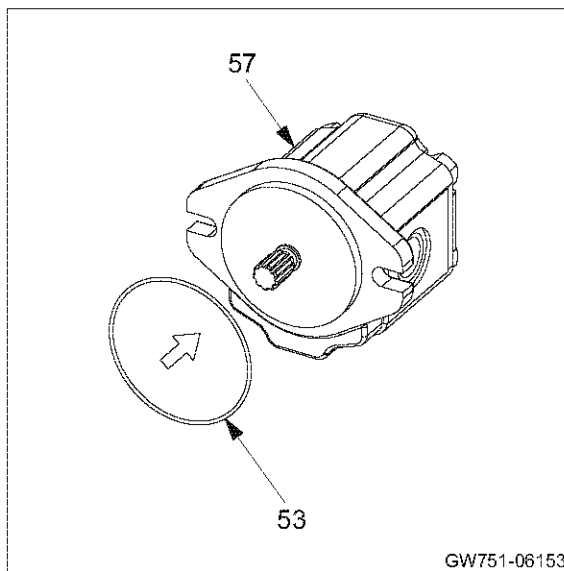

19) Install vibrator motor (57) to cover (61) with two bolts (52) and washers.

(NOTICE)

- Take care not to let O-ring to protrude from its groove.

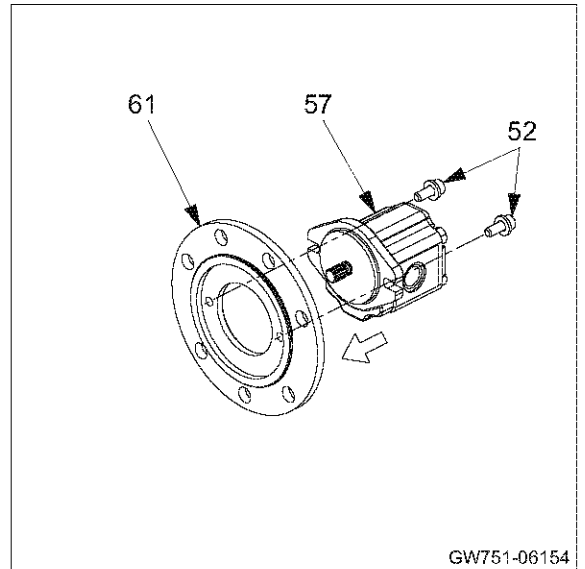

20) Apply grease to O-rings for adapters.

- Install adapters to vibrator motor (57).

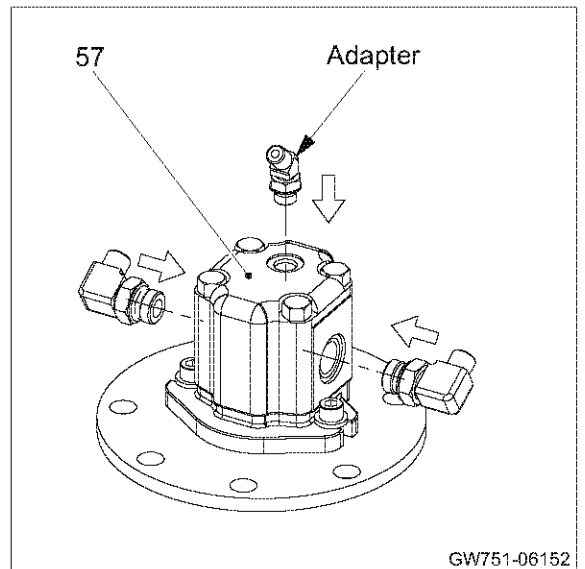

21) Apply grease to O-ring (60).

- Install O-ring to cover (61).

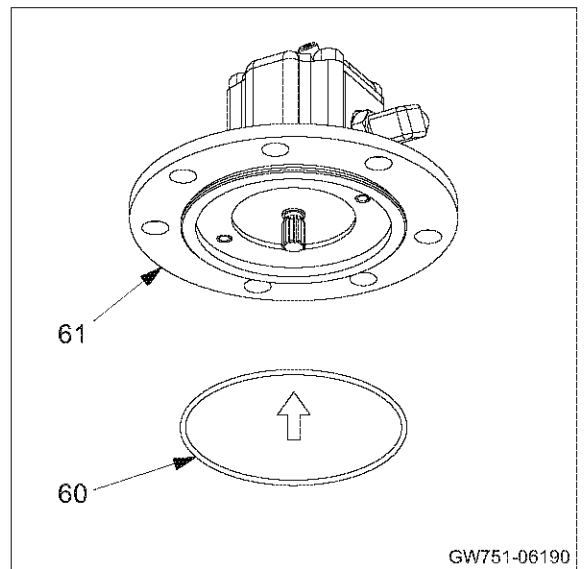

22) Lower vibrator motor SUBASSY on mounting surface of housing (1).

 Vibrator motor SUBASSY : 10 kg (22 lbs.)

(NOTICE)

- Take care not to let O-ring to protrude from its groove.

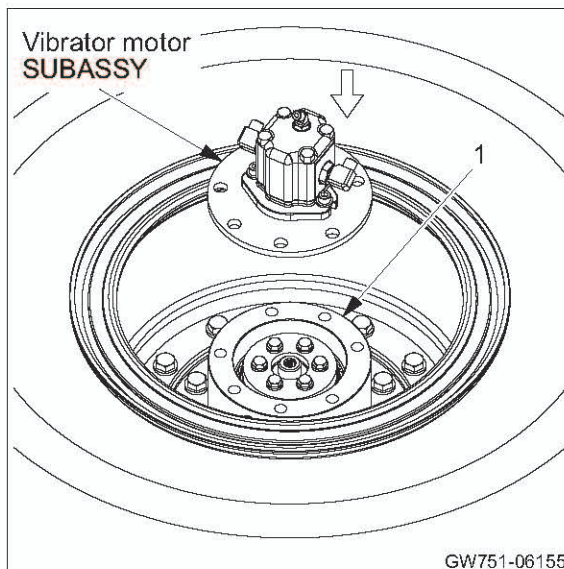

23) Make sure that adapter of vibrator motor SUBASSY and breather (62) is as shown right.

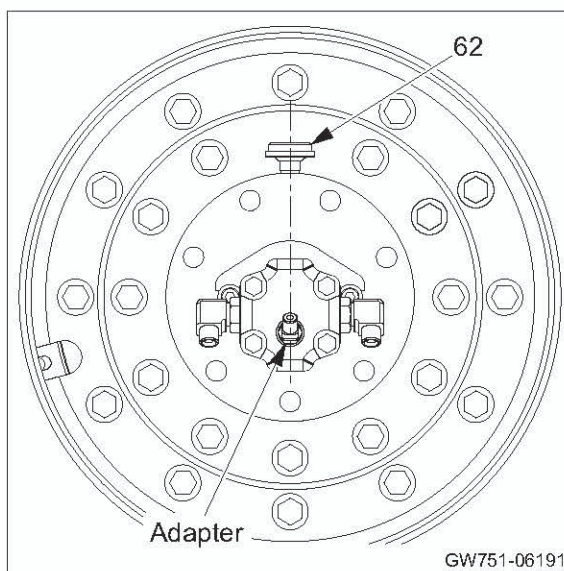

24) Install lifting bolts (M12) to plate (49).

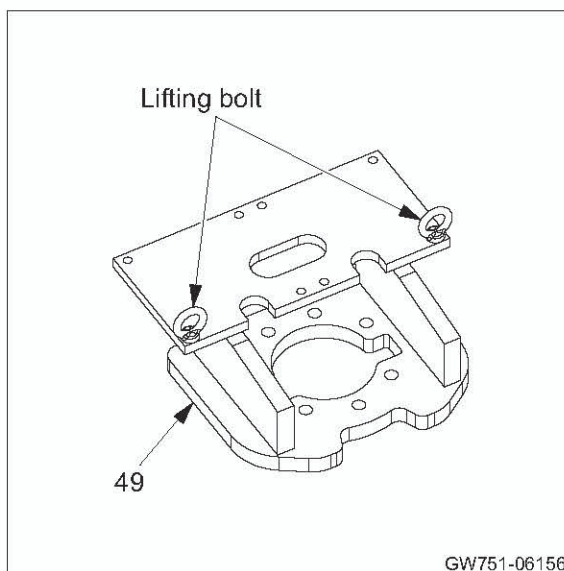

25) Lower plate (49) on mounting surface of cover (61).

 (49) Plate : 35 kg (77 lbs.)

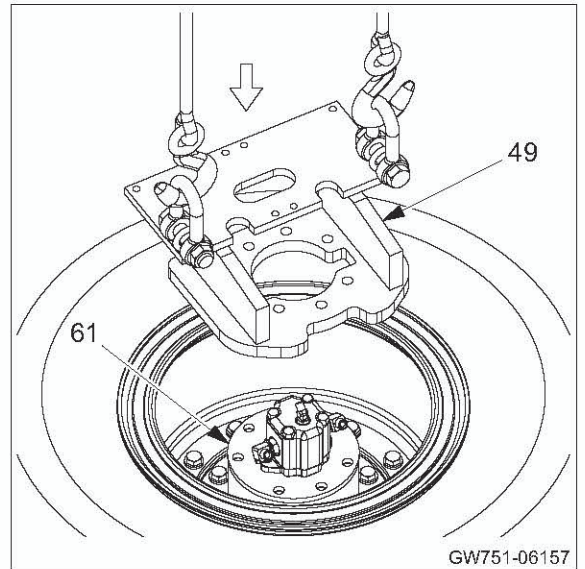

26) Secure plate (49) and vibrator motor SUBASSY to housing (1) with seven bolts (51) and washers.

 (51) Bolts M16×60 : 265 N·m (195 lbf·ft)

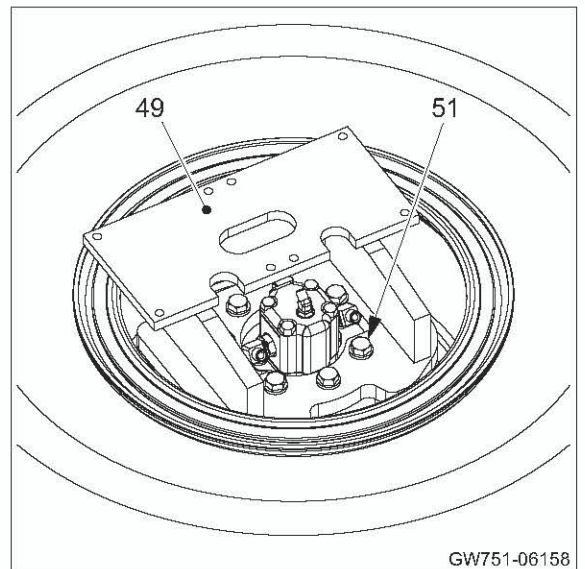

27) Install adapters to vibrator motor (57).

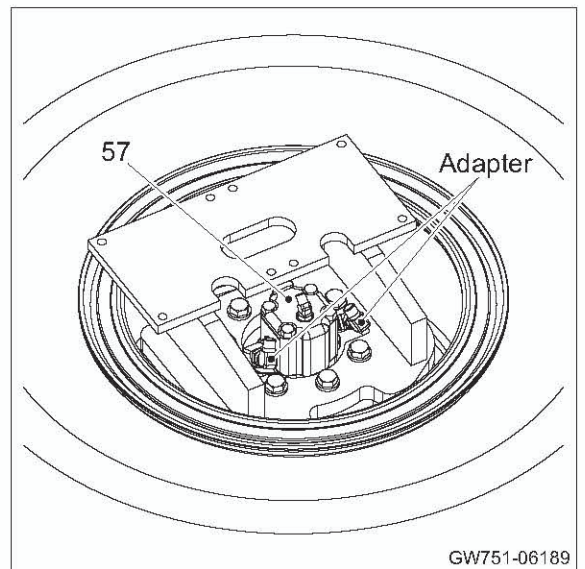

28) Secure two dampers (50) to plate (49) with eight bolts (56) and washers.



(56) Bolts M12×35 : 108 N·m (80 lbf·ft)

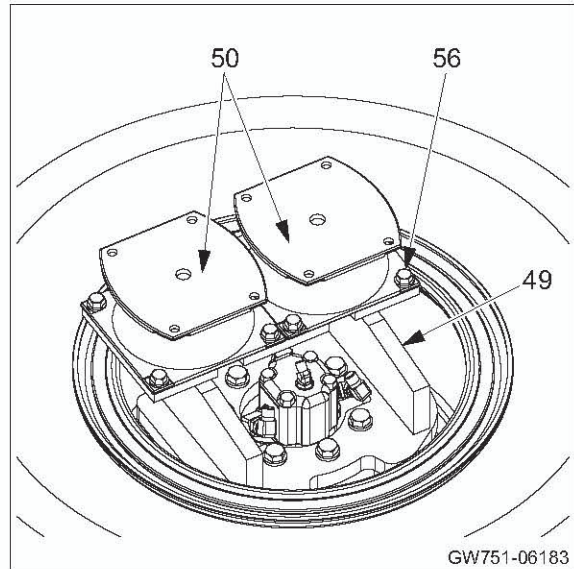

29) Lay wheel SUBASSY.

- Hold with chocks.



Wheel SUBASSY : 645 kg (1,422 lbs.)

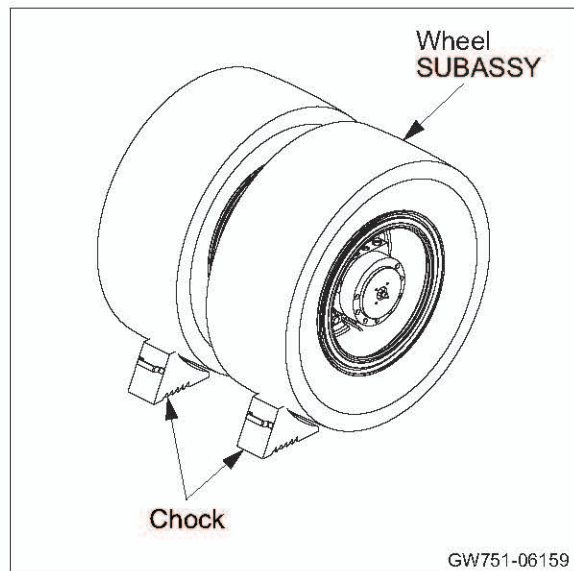

30) Wind seal tape around threaded portion of adapters.

- Install adapters to amplitude cylinder (25).
- Pull out cylinder rod from amplitude cylinder.
- Install adapter (23) to amplitude cylinder.

(NOTICE)

- **Apply liquid packing to mating surfaces of adapter and amplitude cylinder.**
- Apply grease to O-ring (22).
- Install O-ring to adapter.

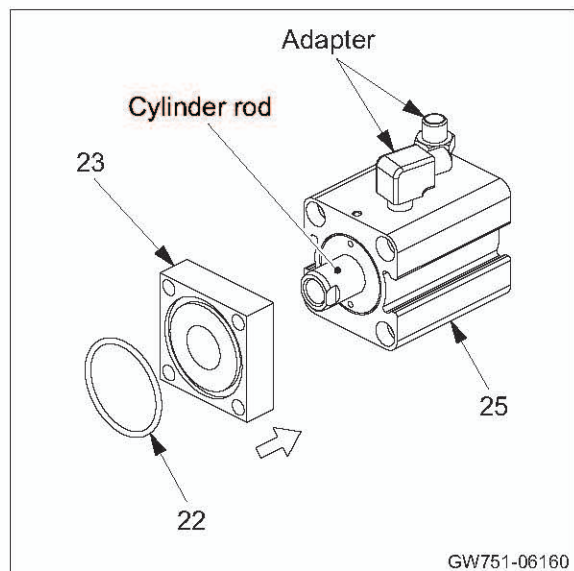

- 31) Using wrenches, install cylinder rod to rod (33).
- Secure amplitude cylinder SUBASSY to propulsion motor (14) with four bolts (26).

(NOTICE)

- Take care not to let O-ring to protrude from its groove.
- Bolts are treated with thread-locking fluid. Use new thread-locking fluid treated bolts for installation.

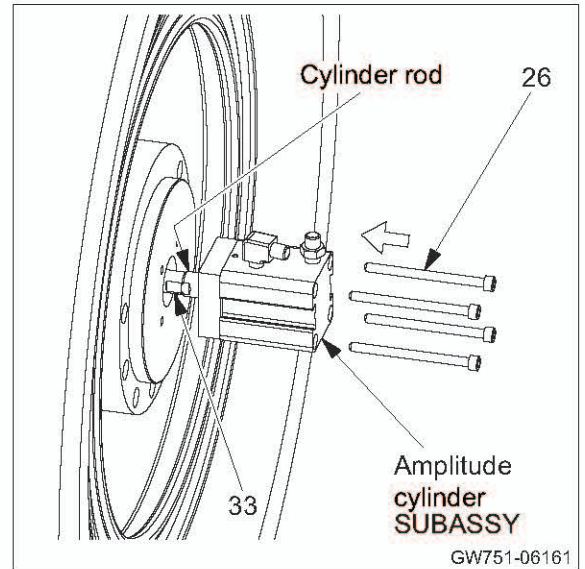

- 32) Install spacer (21) on mounting surface of propulsion motor (14).

 (21) Spacer : 15 kg (33 lbs.)

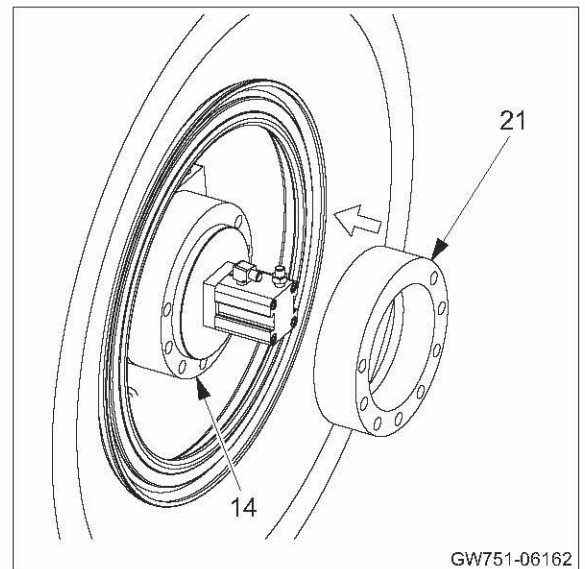

- 33) Connect hydraulic hose to amplitude cylinder (25).

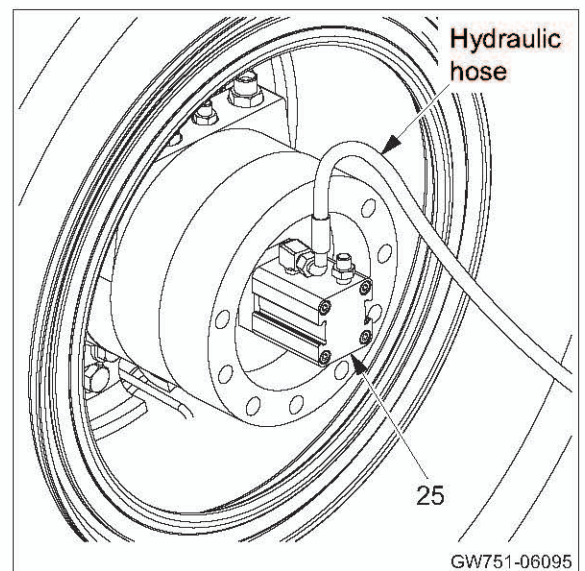

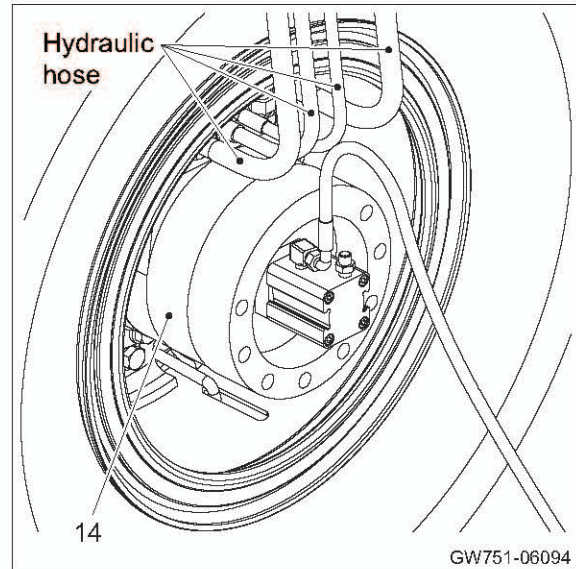

34) Connect four hydraulic hoses to propulsion motor (14).



35) Lift plate (20).

- Secure plate and spacer (21) to propulsion motor (14) with eight bolts (24) and washers.

 (20) Plate : 55 kg (121 lbs.)

 (24) Bolts M16×180 : 265 N·m (195 lbf·ft)

(NOTICE)

- Take care not to damage the hydraulic hose during installation.

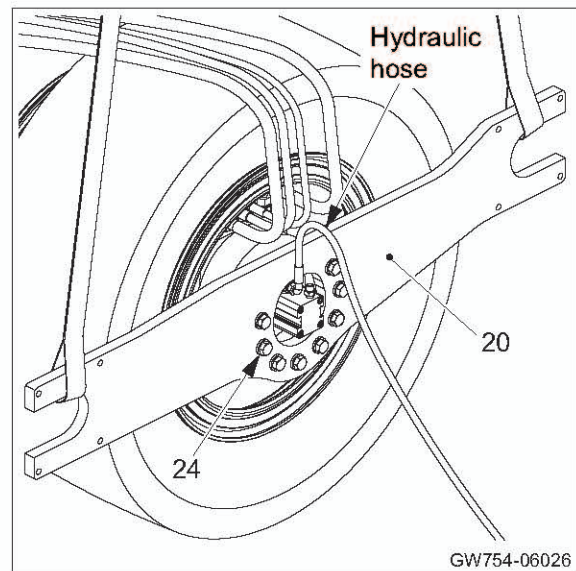

36) Install switch harness to amplitude cylinder (25).

- Connect hydraulic hose to amplitude cylinder.

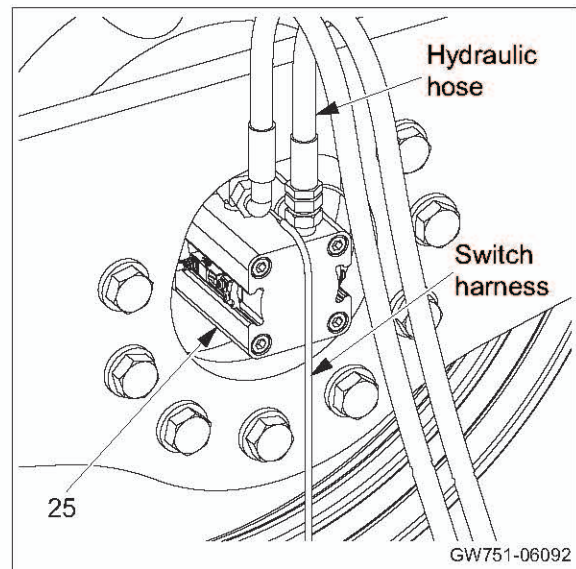

(NOTICE)

- Install switch harnesses to amplitude cylinder (25) at positions shown light.

- ★ Specified dimension a: 23 mm (0.9 in.)
b: 30 mm (1.2 in.)

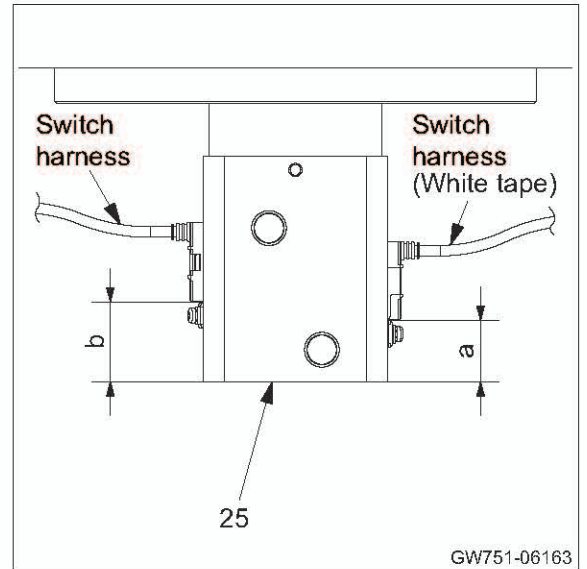

- 37) Secure damper (18) to plate (20) with four bolts (19) and washers.
- Secure damper (30) to plate with four bolts (29) and washers.



(19) Bolts M12×35 : 108 N·m (80 lbf·ft)

(29) Bolts M12×35 : 108 N·m (80 lbf·ft)

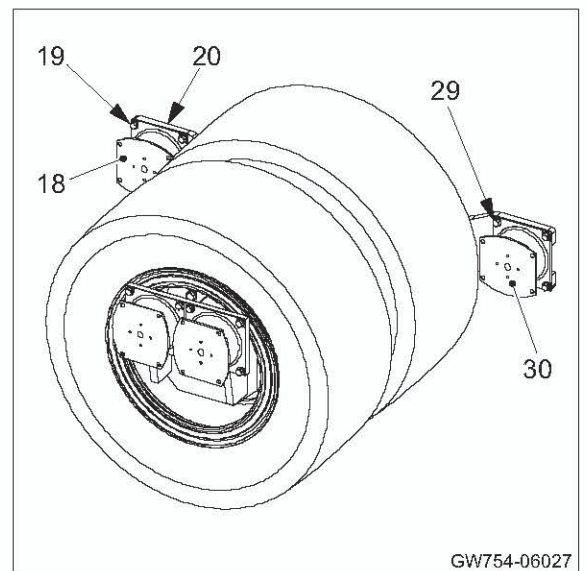

- 38) Place (L) and (R) rear wheel assemblies aligning sidewise.

(NOTICE)

- Use same procedure to reassemble (L) and (R) rear wheel assemblies.

- Lift bracket (27).
- Secure bracket to damper (18) with eight bolts (16), washers and eight nuts (17).



(27) Bracket : 115 kg (254 lbs.)



(16) Bolts M12×40 : 108 N·m (80 lbf·ft)

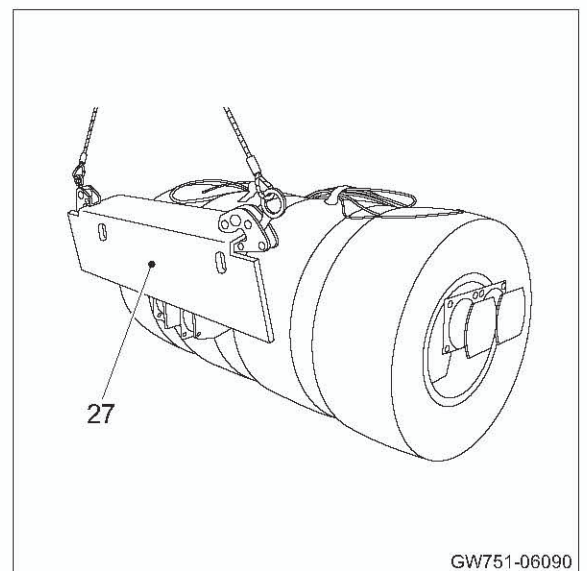

39) Lift bracket (28).

- Secure bracket to damper (30) with eight bolts (31), washers and eight nuts (32).



(28) Bracket : 45 kg (99 lbs.)



(31) Bolts M12×35 : 108 N·m (80 lbf·ft)

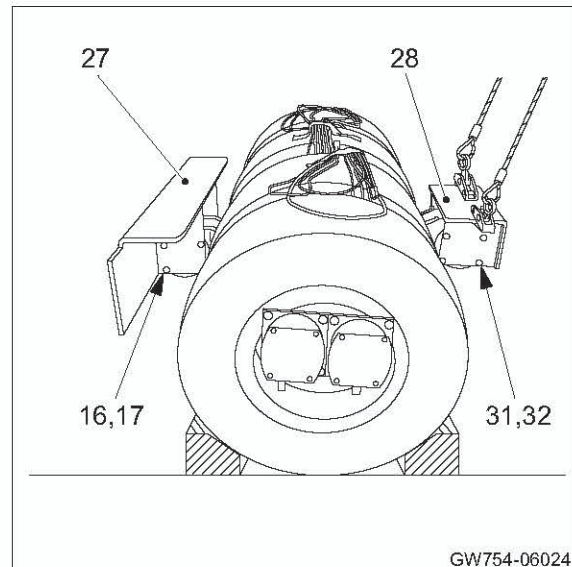

40) Turn drain plug (38-3) or plug (38-1) to point down.

- Remove plug (38-1).

(NOTICE)

- **When plug (38-1) is pointed down, remove drain plug (38-3).**

- Supply gear oil from oil supply port.
 - Quantity of gear oil : 2.5 L (0.66 gal.)

- Remove level plug (38-2).
- Check that oil drips from port.
- Reinstall plug (38-1) and level plug (38-2) to case (7).

(NOTICE)

- **Use same procedure to supply gear oil in (L) and (R) rear wheel assemblies.**

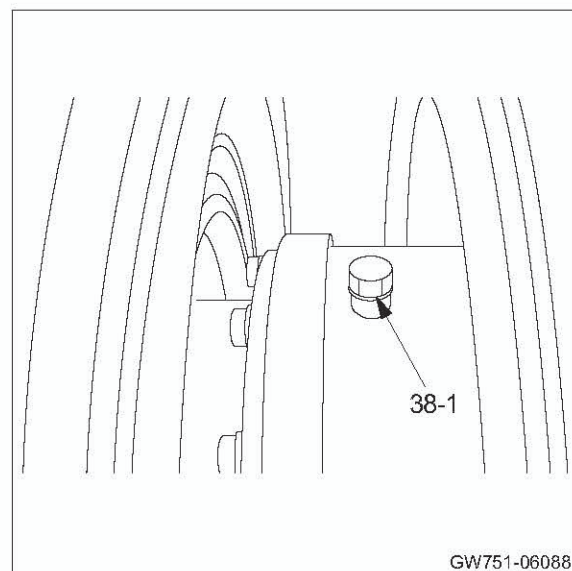

BRAKE

1. BRAKE PEDAL

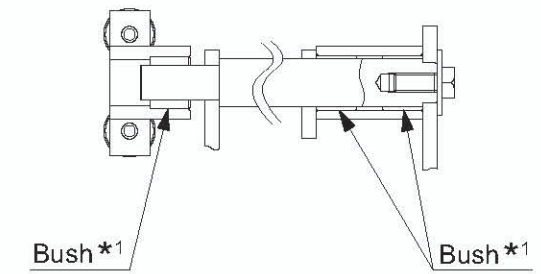
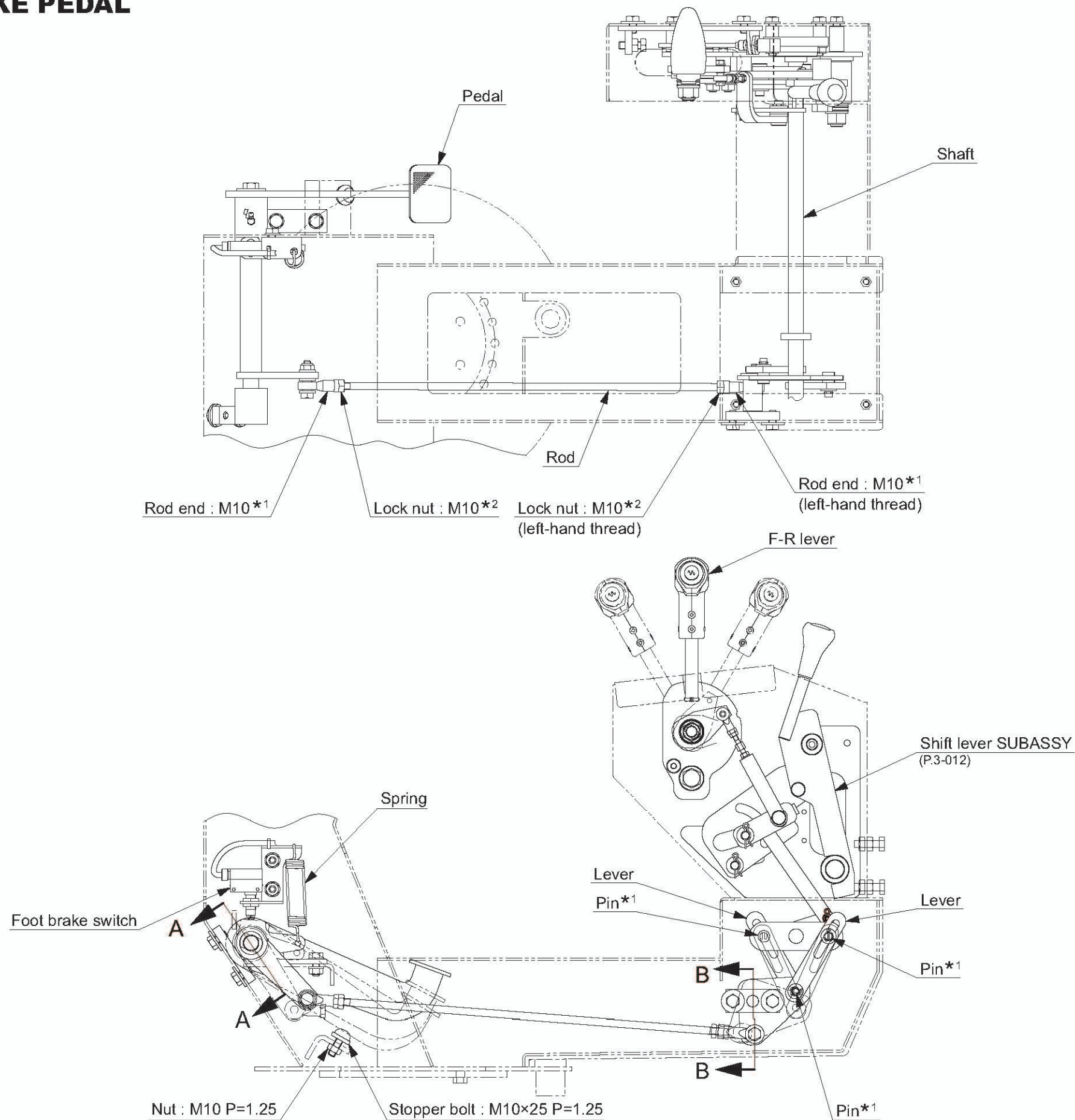

SECTION A-A

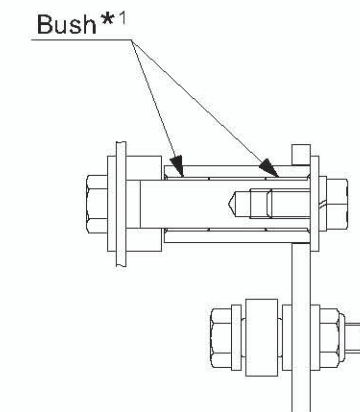

SECTION B-B

*1 : Apply Lithium-based grease
 *2 : Coat grease

Fig.: Brake circuit

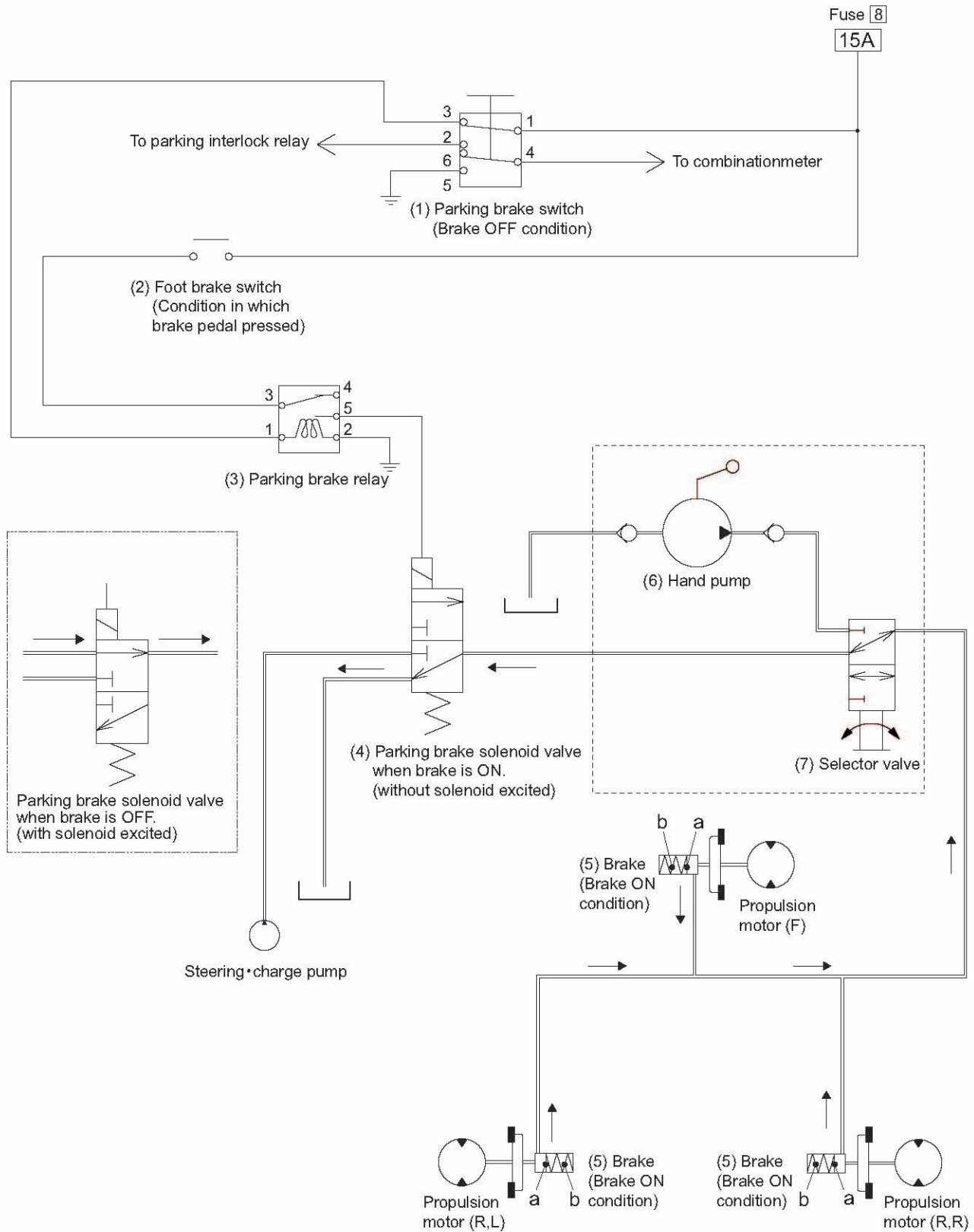

• The arrow (→) symbol shows the direction of the hydraulic oil flow.

2. BRAKE SYSTEM

2-1. Description and Operation of Brake Circuit

Description

- Made up of parking brake switch (1), foot brake switch (2), parking brake relay (3), parking brake solenoid valve (4) and brake (5). The foot brake switch is ON with the brake pedal released and OFF if pushed down on.

Operation

To release parking brake:

- When parking brake switch (1) is set to the OFF position, the contacts of parking brake switch (1) close the circuit to parking brake solenoid valve (4).
- This leads the pressurized fluid through parking brake solenoid valve (4) to pistons (a) of brake (5) to compress springs (b). Brake is freed.

To apply parking brake (Brake pedal not depressed):

- If parking brake switch (1) is put in the ON position, the contacts of parking brake switch (1) break the circuit to parking brake solenoid valve (4).
- This stops feeding the fluid from parking brake solenoid valve (4) to brake (5). Springs (b) move pistons (a) toward the brake discs and plates so that they make a close contact with each other.

When brake pedal is pushed down on:

- If brake pedal is depressed, foot brake switch (2) is switched off to break the circuit to parking brake relay (3). This applies the brake even if parking brake switch is in the OFF position.
- F-R lever is returned to N position through shift lever SUBASSY.

To disengage the brake when towing:

- Loosen lock ring of selector valve (7) and turn selector valve counterclockwise.
- Turn the unloader valve clockwise to release it.
- Pull up and press the knob of the hand pump (6) slowly. The brake can be released by pressing it about 13 times. When the operation force is felt heavy, the brake is released. Stop the operation at that time. Continued operation may cause damage to the machine.
- Turn the unloader valve counterclockwise to engage the drive.
- After towing is completed, turn selector valve (7) clockwise until it stops. And fix selector valve with the lock ring.
- For the unloader valve location refer to page 4-004.
- For the lock ring location refer to page 4-014.

OPERATOR STATION

1. FLOORBOARD

1-1. Structure of Operator Station

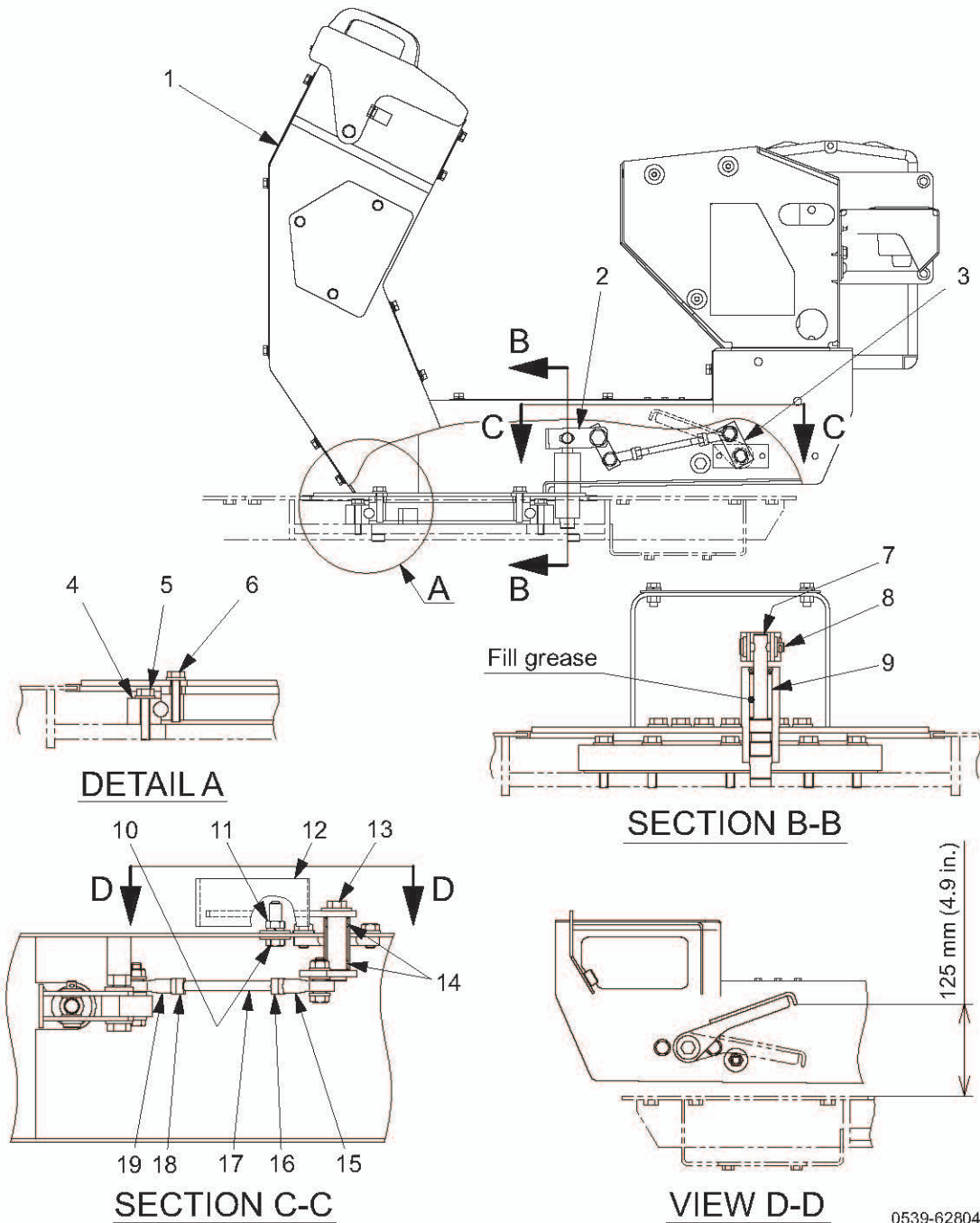

0539-62804-0-11033-B

- | | | |
|------------------------------------|-----------------------------|--------------------------|
| (1) Dashboard ASSY | (11) Nut | : M10 |
| (2) Lever | (12) Pedal | |
| (3) Pin | (13) Bolt | : M10×20 |
| (4) Turn bearing | (14) Bush (Apply grease) | |
| (5) Bolt : M10×50 | (15) Rod end (Apply grease) | : M10 (left-hand thread) |
| (6) Bolt : M10×50 | (16) Nut (Apply grease) | : M10 (left-hand thread) |
| (7) Pin | (17) Rod | |
| (8) Pin (Apply grease) | (18) Nut (Apply grease) | : M10 |
| (9) Spring | (19) Rod end (Apply grease) | : M10 |
| (10) Bolt (pedal stopper) : M10×40 | | |



(13) Bolt M10×20 : 49 N·m (36 lbf·ft)

1-2. Adjustment of Swivel Lock Release Pedal

- ① Loosen the nuts (16) and (18).
- ② Insert the pin (7) into the fixing hole to lock the pedal (12).
- ③ Using the rod (17), adjust the pedal height in the locked condition.
 - ★ Pedal height: 125 mm (4.9 in.)
- ④ With the pedal still locked, check that there is no looseness in the dashboard.
- ⑤ Depress the pedal and check that the lock is smoothly released.
- ⑥ If the above checks (④ and ⑤) show no problem, tighten the nuts to fix the pedal.

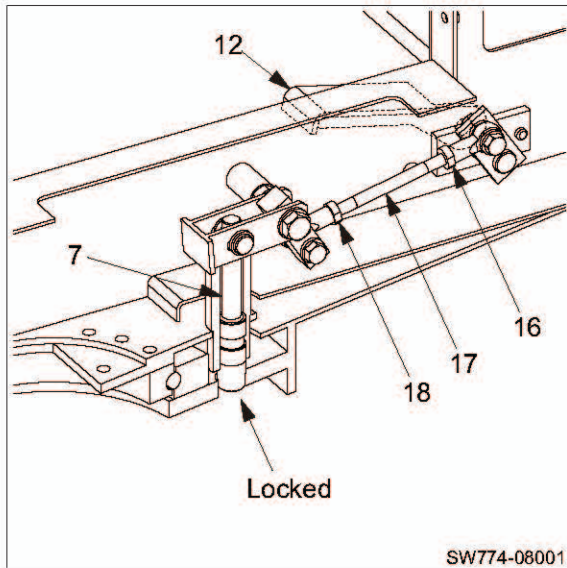

Pedal released

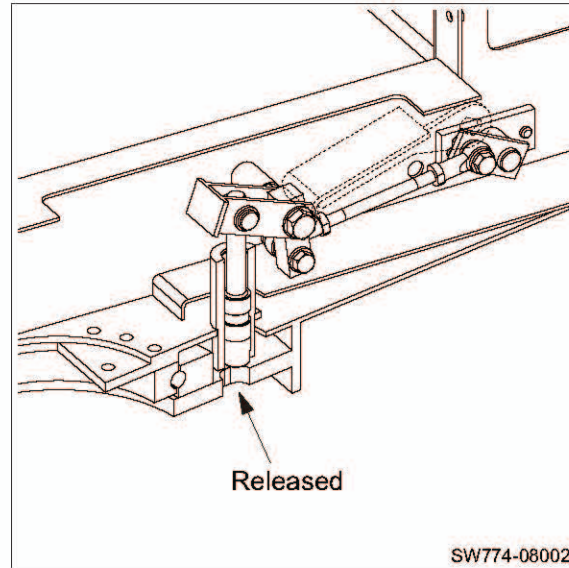

Pedal depressed

- The numbers in parentheses that appear in the above sentences and the numbers in the above illustrations are consistent with the lead line numbers shown in "1-1. Structure of Operator Station" (page 8-001).

WATER SPRAY SYSTEM

1. WATER SPRAY PIPING

1-1. Water Spray Piping (1)

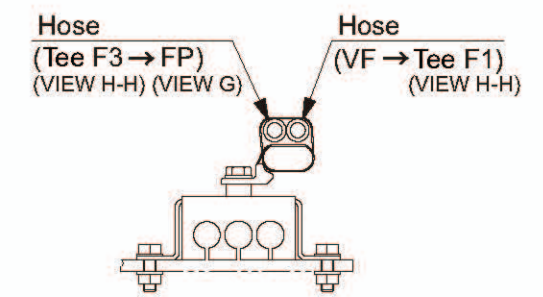
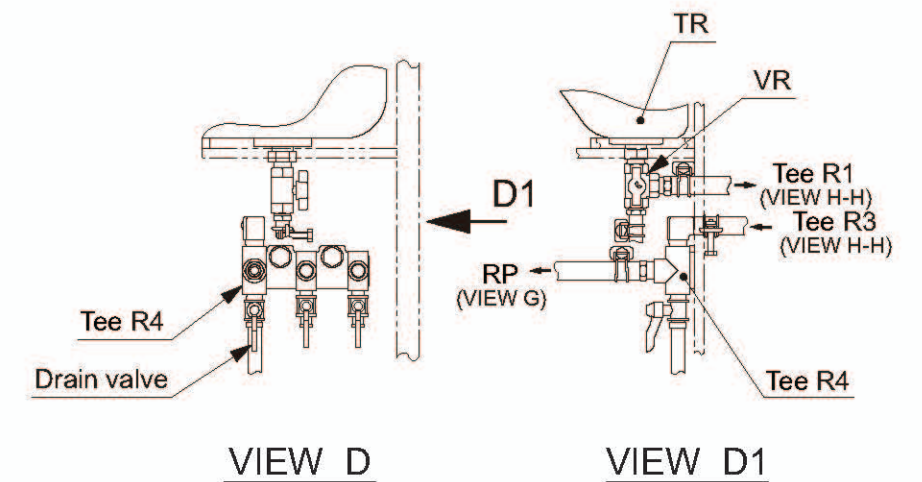
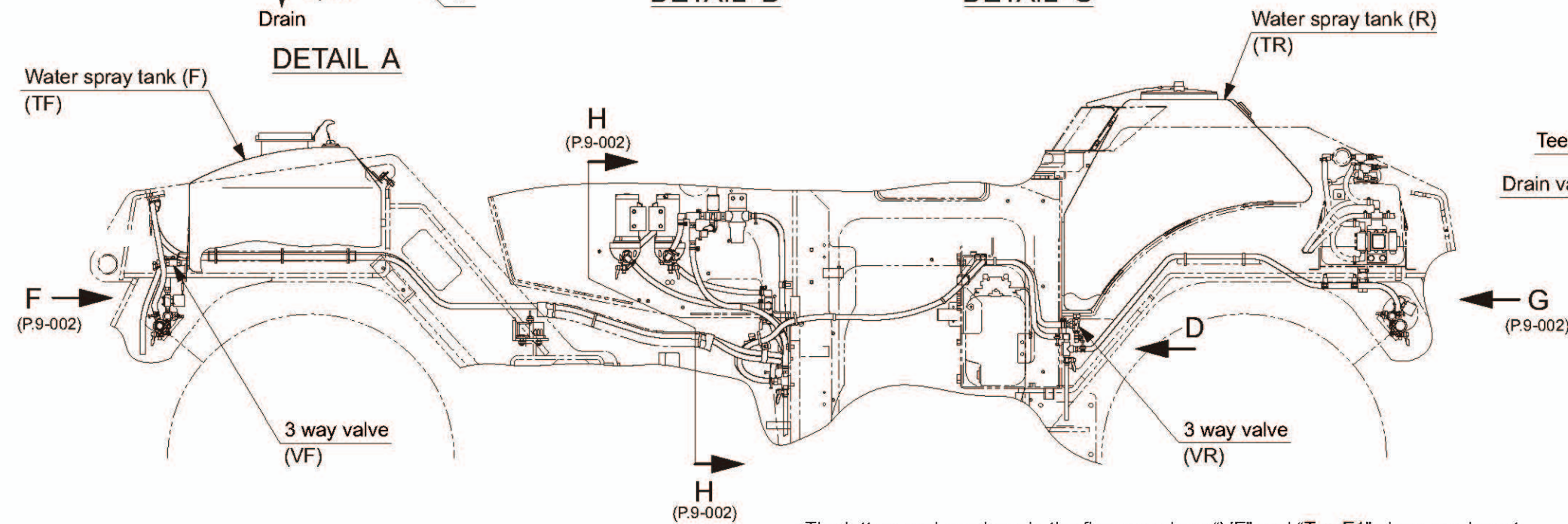
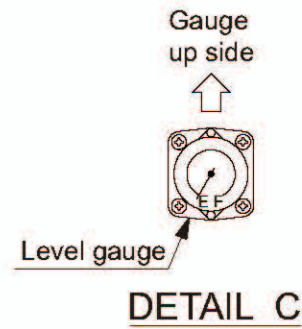
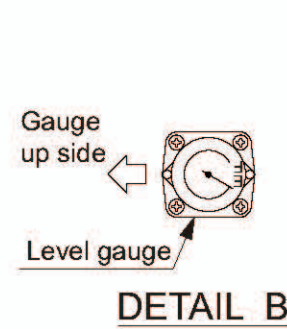
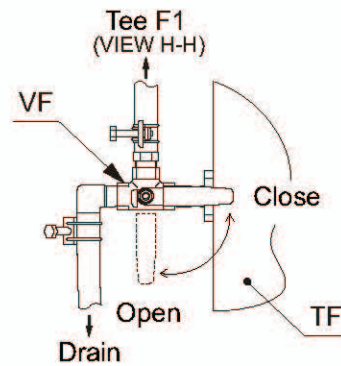
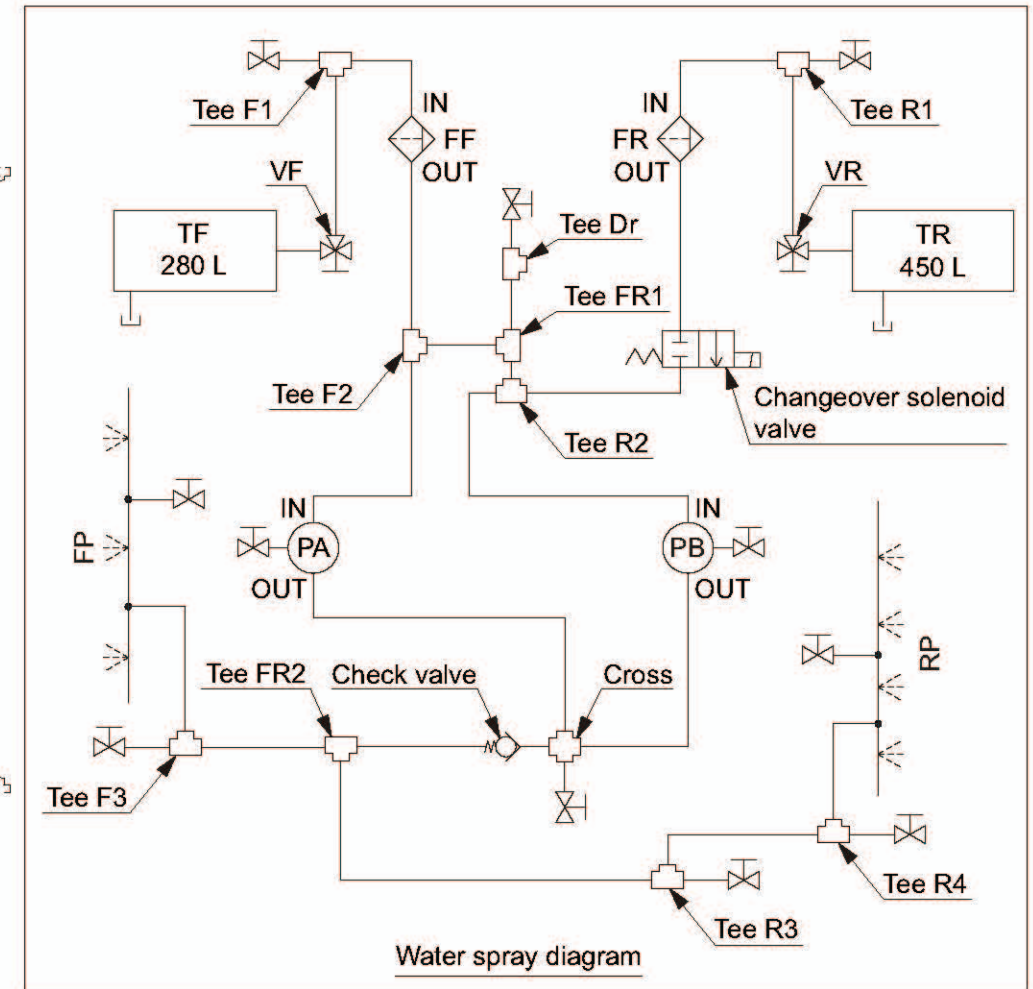
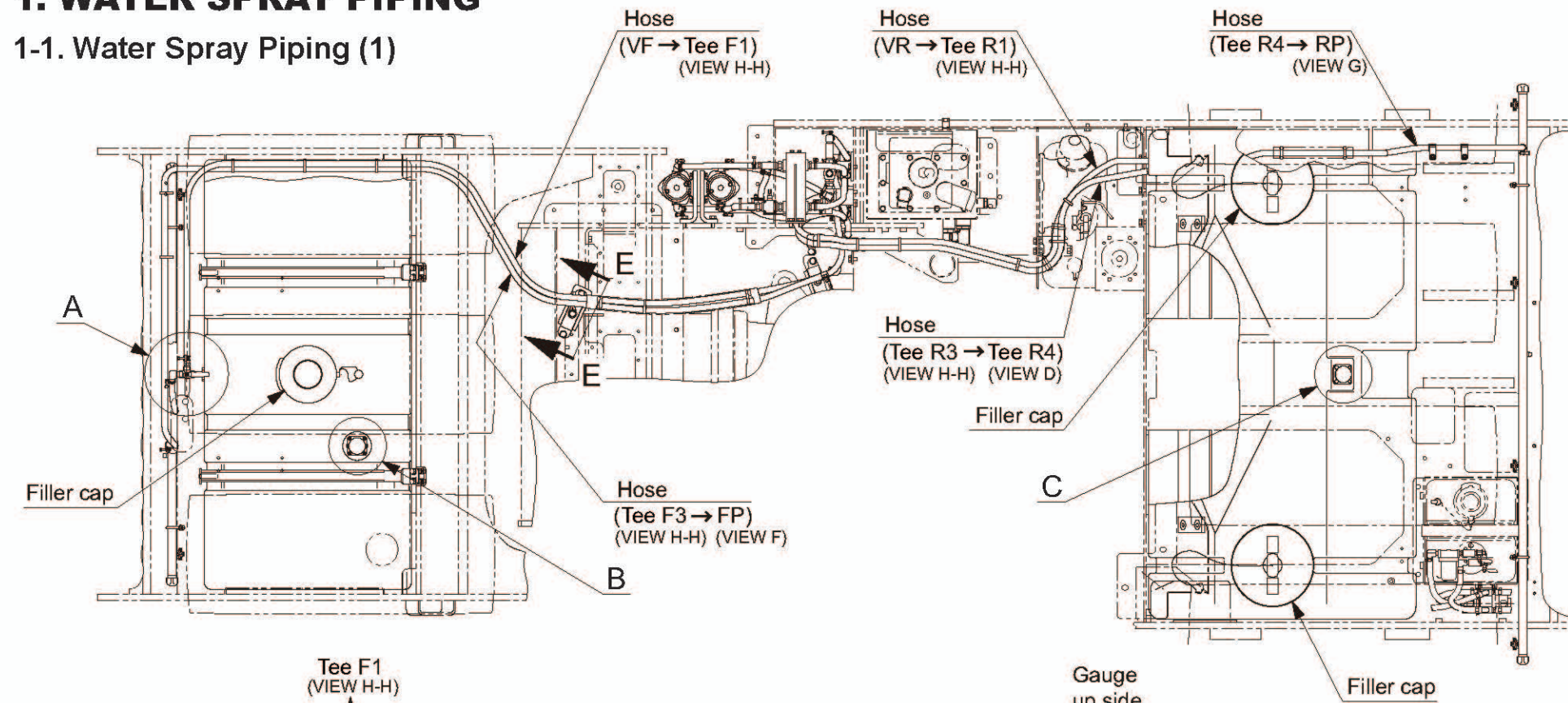

- The letters and numbers in the figure such as "VF" and "Tee F1" show each port.
- Arrow "→" symbols show the hose connection and the direction of the flow of the water.

2. LIQUID SPRAY SYSTEM

2-1. Liquid Spray Piping (1)

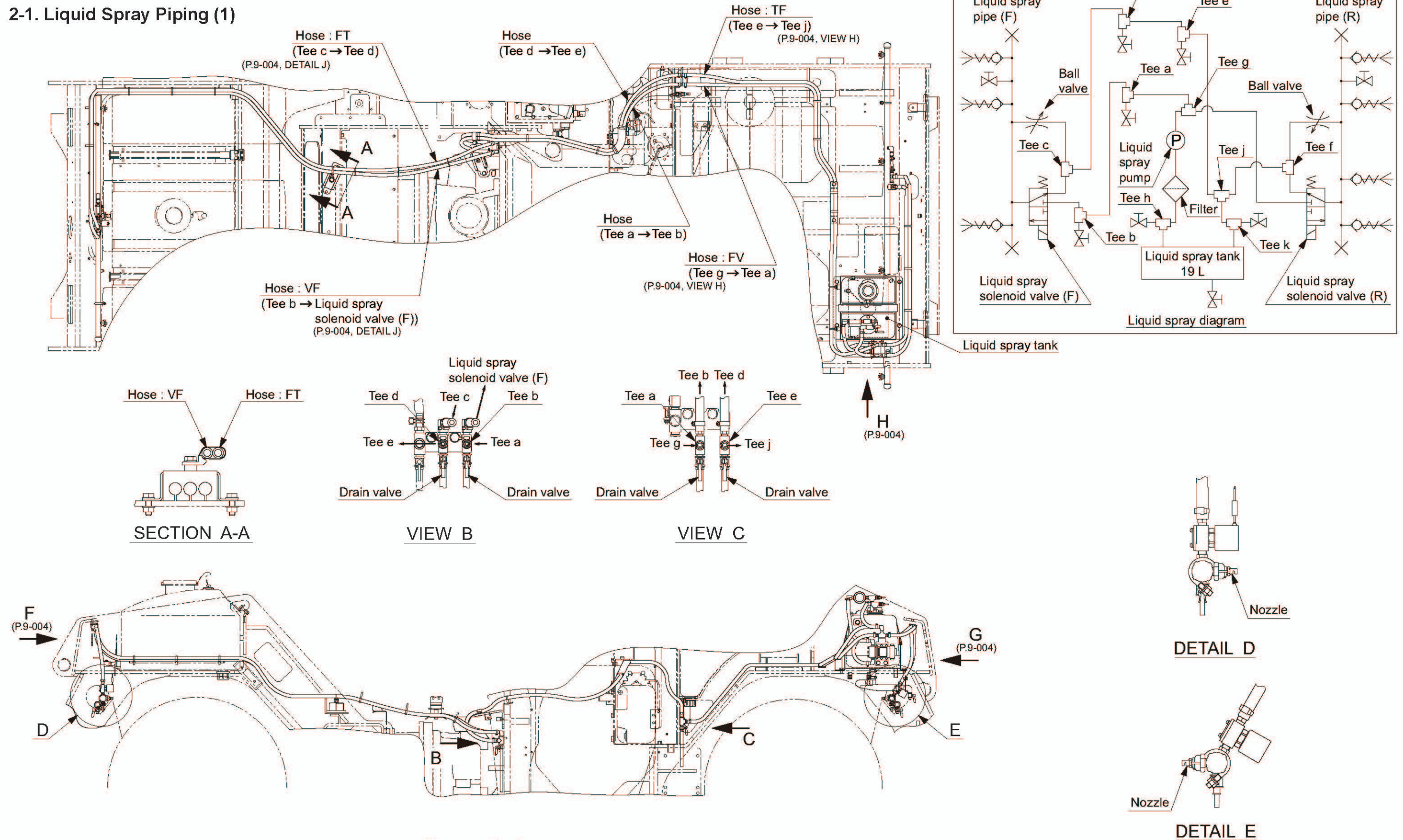

- The letters and numbers in the figure such as "Tee a" and "Tee b" show each port.
- Arrow "→" symbols show the hose connection and the direction of the flow of the liquid.

2-2. Liquid Spray Piping (2)

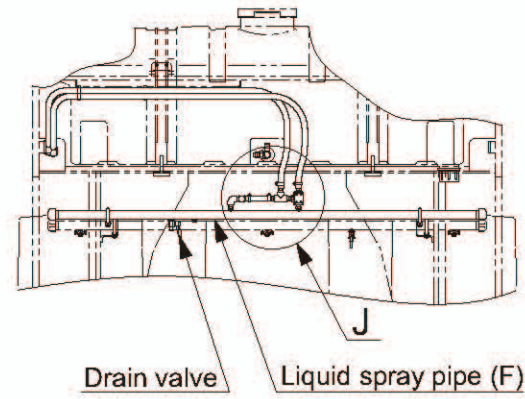

VIEW F

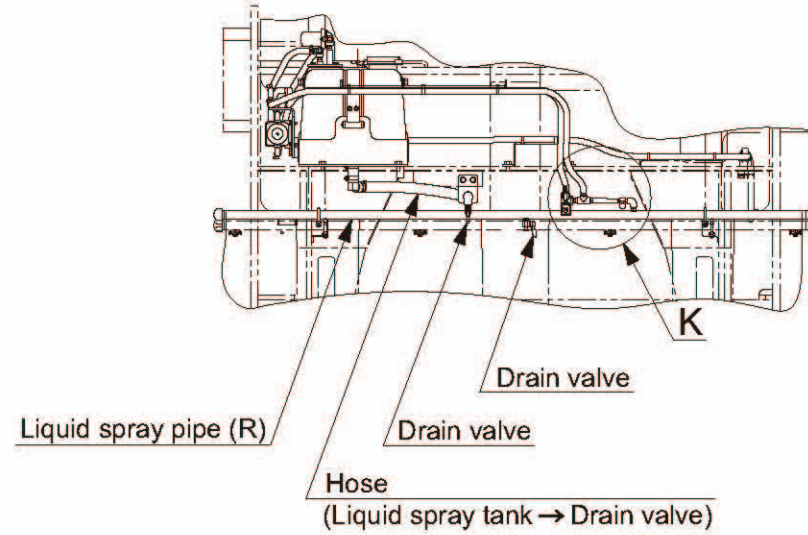

VIEW G

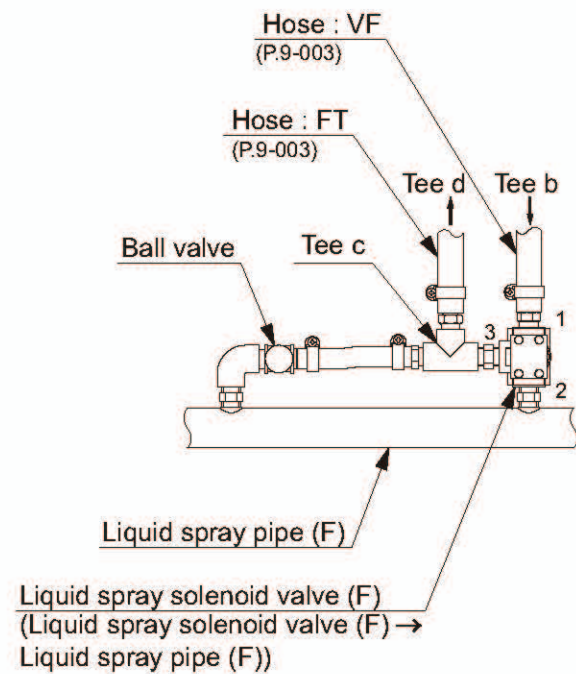
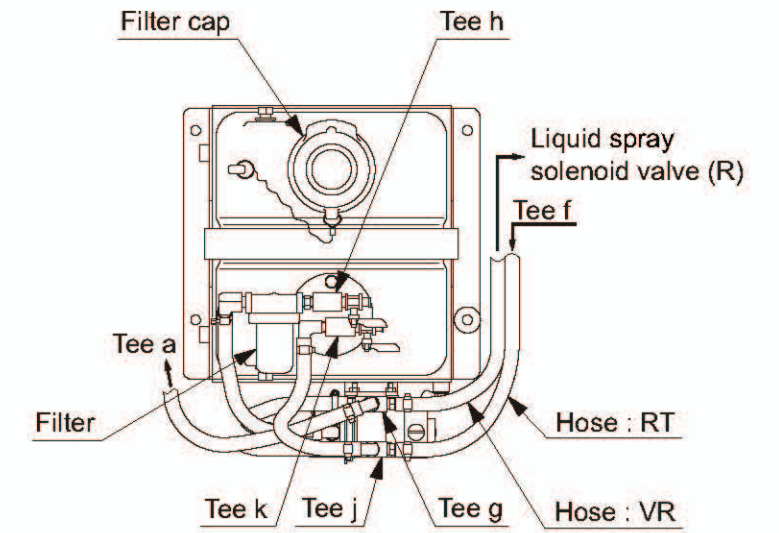

DETAIL J

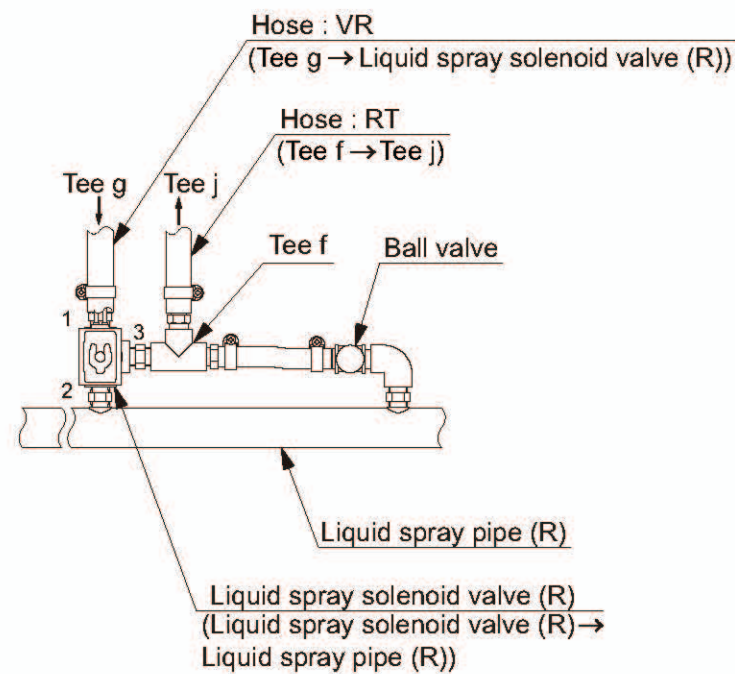

DETAIL K

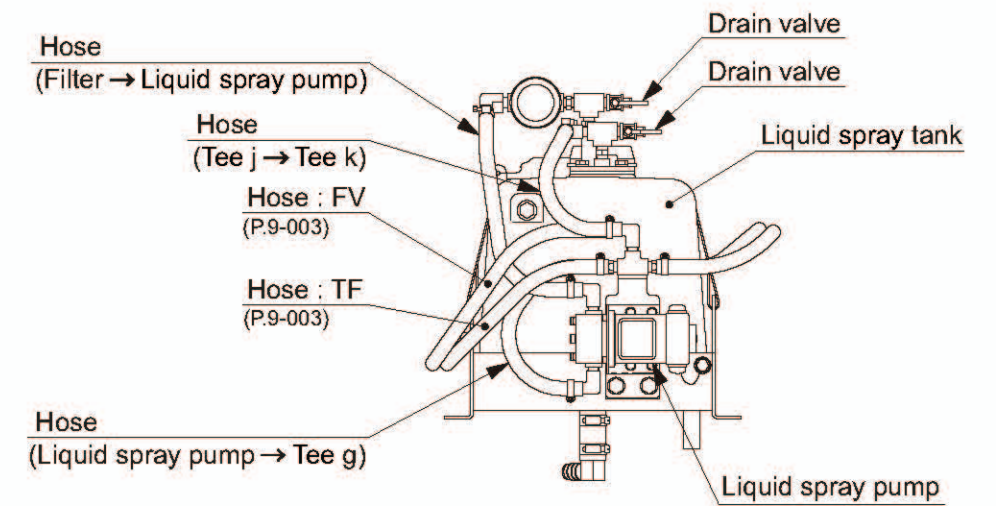

VIEW H

- The letters and numbers in the figure such as “Tee f” and “Tee j” show each port.
- Arrow “→” symbols show the hose connection and the direction of the flow of the liquid.

3. WATER SPRAY COMPONENT SPECIFICATIONS

3-1. Change Over Solenoid Valve

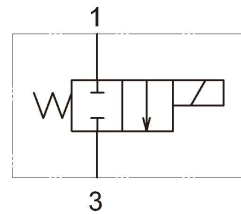
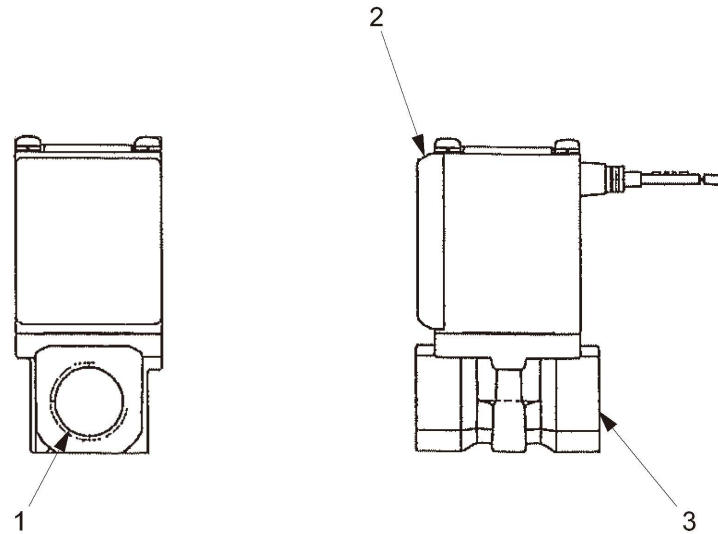

Circuit diagram

GW754-09001

- (1) Port (IN) : G1/2
- (2) Solenoid
- (3) Port (OUT) : G1/2

Specifications

- Maximum pressure : 1.0 MPa (145 psi)
- Rated voltage : DC 12 V
- Power consumption : 10.5 W

3-2. Liquid Spray Solenoid Valve (F), (R)

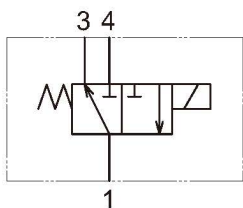
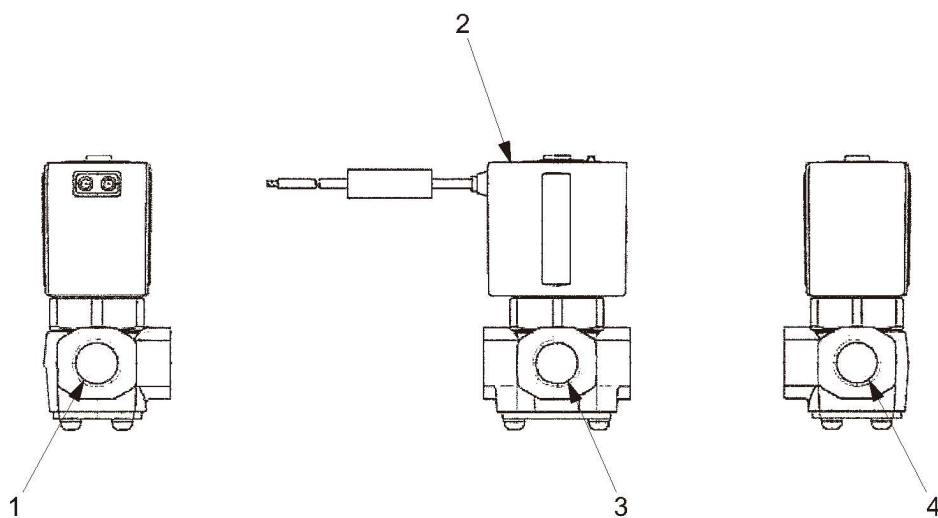

Circuit diagram

- Without solenoid excited
- 1→3
- With solenoid excited
- 4→1

GW754-09002

- (1) Port (OUT) : G1/4
- (2) Solenoid
- (3) Port (EXH) : G1/4
- (4) Port (IN) : G1/4

Specifications

- Maximum pressure : 2.0 MPa (290 psi)
- Rated voltage : DC 12 V
- Power consumption : 4.5 W

INSPECTION AND ADJUSTMENT

1. INSPECTION AND ADJUSTMENT

1-1. Safety Precautions for Inspection and Adjustment

⚠ WARNING

Unexpected machine movement may cause a serious accident. When inspecting the machine while the engine is running, always follow the instructions below.

- Park the machine on level, flat ground.
- Apply the parking brake.
- Set chocks in front and behind each drum or tire.
- Make sure that service personnel are given the appropriate information at the appropriate time.
- Make sure that no one can enter any hazardous area.

⚠ CAUTION

Do not work on the hydraulic system while the engine is running and the system is hot and under pressure. Do not disconnect hydraulic hoses or fittings until the system has cooled and pressure has been properly relieved.

Before removing any plugs from the pressure measurement ports, always release any residual pressure from the piping and open the cap of the fluid tank to release and pressure.

⚠ WARNING

Inadvertent starting the engine may cause a serious accident.

When inspecting the engine, make sure to exchange the appropriate cues and hand signal with the person at the operator station to avoid any accidents.

⚠ CAUTION

Before inspecting inside of the engine compartment, always stop the engine.

Contact with the fan, V-belt or exhaust system parts while the engine is running may cause serious injury.

1-2. Preparation for Inspection and Adjustment

- Prepare the necessary measuring instruments. In addition, particularly when measuring pressure values, make sure to prepare the appropriate hoses, adapters and a plug removal tool for the pressure reading port.
- Make sure that the instruments to be used operate normally.

When handling the instruments, exercise sufficient caution not to drop or apply any impact to them. Doing so may adversely affect the calibration. Another important point is to inspect the instruments regularly. An instrument that does not start from the appropriate zero point may give an inaccurate reading.

1-3. Precautions for Inspection and Adjustment

- When performing inspections and adjustments, pay special attention to safety.
- For each inspection, always take three measurements for each measurement point. If the measurements significantly differ, the measurement method may be incorrect. In such a case, take measurements once again and calculate their average.

1-4. Warm-up

- Machinery will not exhibit their true performance under the cold condition. Before taking measurements, always warm up the engine and make sure that the fluid and engine coolant are warmed to their specified normal operating temperatures.

1-5. Inspection and Adjustment of Engine Related Items

- Refer to shop manual of engine manufacturer for inspection and adjustment of engine itself.

2. MEASUREMENT AND INSPECTION OF PROPULSION CIRCUIT PRESSURE

2-1. Measurement

⚠ WARNING

Confirm that the parking brake works properly before measurement.

- Oil temperature during measurement : $50 \pm 5^{\circ}\text{C}$ ($122 \pm 9^{\circ}\text{F}$)

① Remove plugs from system gauge port (5) and (18) of propulsion pump. Attach pressure gauge with adapter (h).

- Adapter (h) : 9/16-18UNF
- System gauge port (Forward) : (5)
- System gauge port (Reverse) : (18)
- Pressure gauge : 0 to 50 MPa
(0 to 7,250 psi)

② Confirm that F-R lever is "N".

③ Apply parking brake by pressing parking brake switch button.

④ Set shift lever to "Hi".

⑤ Start the engine and set throttle switch to "Full".

⑥ Establish a condition in which machine propulsion load becomes maximum.

(Pressure does not build up unless propulsion load is applied.)

⑦ With propulsion load at maximum, slowly move F-R lever to the side to be measured.

⑧ Read pressure indicated by pressure gauge.

⑨ After measuring, promptly return F-R lever to "N".

★ Maximum circuit pressure

(high pressure relief valve pressure setting)

: 40 ± 1.0 MPa ($5,800 \pm 145$ psi)

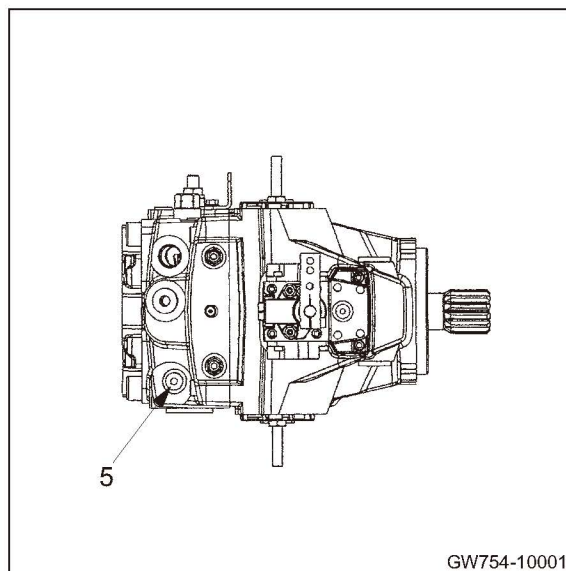

GW754-10001

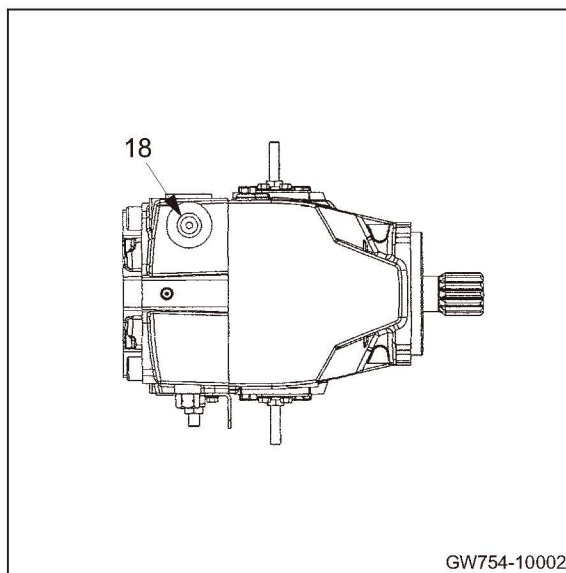

GW754-10002

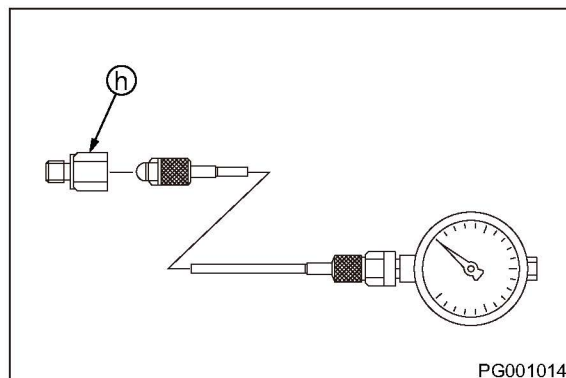

PG001014

- The number "5" and "18" appearing in above illustrations are consistent with lead line numbers shown in illustration of propulsion hydraulic pump in "2-2. Hydraulic Component Specifications" (P.4-007).

2-2. Inspection

- If measurement results indicate the pressure deviating from standard maximum circuit pressure range, make an inspection in accordance with procedure described below.

- ① Remove high pressure relief valve (13) and (16) from propulsion pump.
 - High pressure relief valve (Forward) : (13)
 - High pressure relief valve (Reverse) : (16)
- ② Check removed high pressure relief valve for trapped dirt, scratches on its seat and other abnormalities.
- ③ If trapped dirt is present, clean high pressure relief valve.
- ④ If a scratch is found on seat, replace high pressure relief valve.
- ⑤ After inspection, measure pressure again and check that pressure reaches standard maximum circuit pressure range.

 N·m (13)
 (16) High pressure relief valve : 40 N·m (30 lbf·ft)

(NOTICE)

- **Carefully disassemble and reassemble after taking steps to prevent foreign material from getting in.**

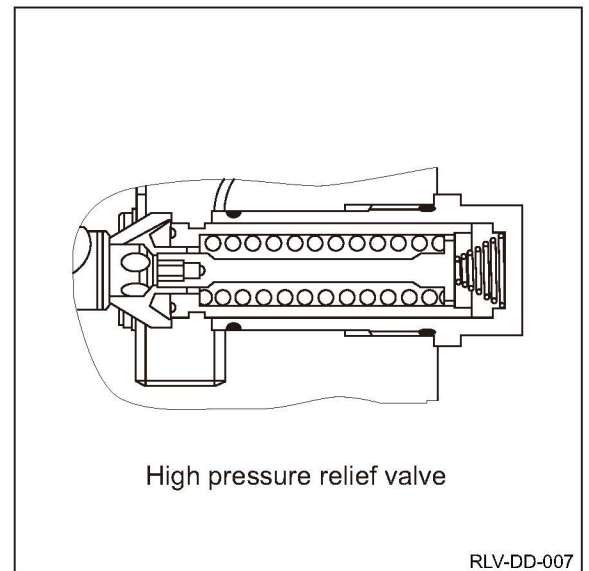
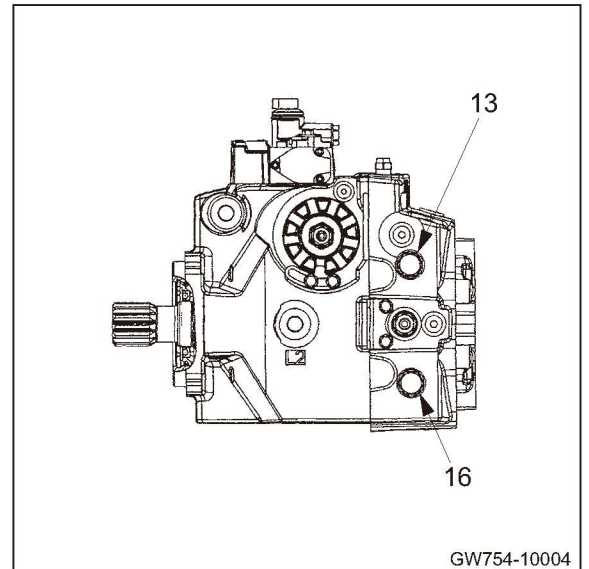

- The number “13” and “16” appearing in above illustrations are consistent with lead line numbers shown in illustration of propulsion hydraulic pump in “2-2. Hydraulic Component Specifications” (P.4-007).

3. MEASUREMENT AND ADJUSTMENT OF PROPULSION CHARGE CIRCUIT PRESSURE

- Since oil in charge circuit is supplied from steering circuit, confirm that steering operation is normal before measurement.
- Ensure that neutral positions of F-R lever and propulsion pump are aligned.

3-1. Measurement

- Oil temperature during measurement : $50 \pm 5^{\circ}\text{C}$ ($122 \pm 9^{\circ}\text{F}$)
- ① Remove plug from coupling (1) of hydraulic oil filter 2.
Attach pressure gauge with hose (S) and connector (U).
 - Coupling : 9/16-18UNF×M16
 - Adapter for hose (S) : M16 P=2.0
 - Pressure gauge connector (U) : M16×G3/8
 - Pressure gauge : 0 to 5 MPa (0 to 725 psi)
- ② Confirm that F-R lever is "N".
- ③ Apply parking brake by pressing parking brake switch button.
- ④ Start the engine and set throttle switch to "Full".
- ⑤ Read pressure indicated by pressure gauge.

★ **Standard charge pressure relief valve setting**
: 2.4 ± 0.2 MPa (348 ± 29 psi)

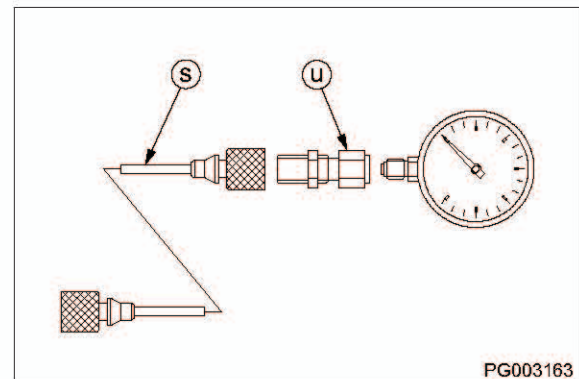
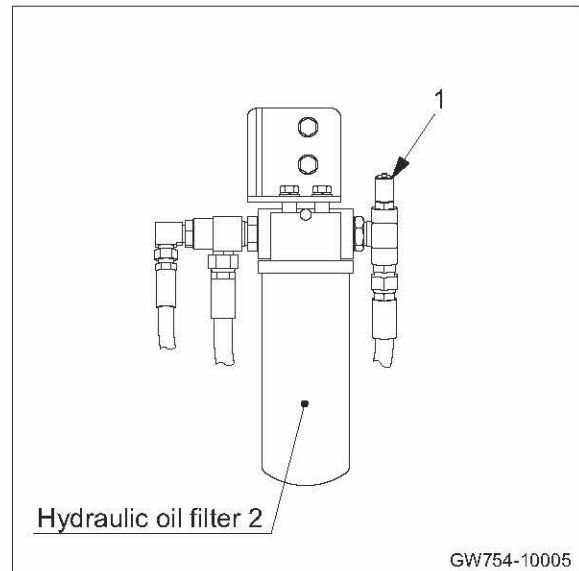

3-2. Adjustment

- If measurement results indicate the pressure deviating from standard charge relief pressure setting range, make an adjustment in accordance with procedure described below.
 - ① Check nut (2) of charge pressure relief valve (14) for evidence of having loosened.
 - ② If there is evidence of nut having loosened, adjust charge pressure relief valve so that pressure becomes within standard charge pressure relief valve setting range while watching pressure gauge.
 - To adjust pressure, loosen nut and turn adjustment screw (3).
- Adjustment screw turned clockwise
: Pressure rise
- Adjustment screw turned counterclockwise
: Pressure drop
- Pressure change rate : 0.39 MPa/turn (56.6 psi/turn)
- ③ If there is no evidence of nut having loosened, remove it.
 - ④ Check removed charge pressure relief valve for trapped dirt and scratches on its seat.
 - ⑤ If trapped dirt is present, disassemble and clean charge pressure relief valve.
 - ⑥ If a scratch is found on seat, replace charge pressure relief valve.
 - ⑦ After adjustment, measure pressure again and check that pressure reaches standard charge pressure relief valve setting range.



- | | | |
|-----------------------------------|---|--------------------------------|
| (2) Nut | : | 12 N·m (8.9 lbf·ft) |
| (14) Charge pressure relief valve | : | 47 to 57 N·m (35 to 42 lbf·ft) |

(NOTICE)

- **Carefully disassemble and reassemble after taking steps to prevent foreign material from getting in.**
- The number “14” appearing in above illustrations is consistent with lead line numbers shown in illustration of propulsion hydraulic pump in “2-2. Hydraulic Component Specifications” (P.4-007).

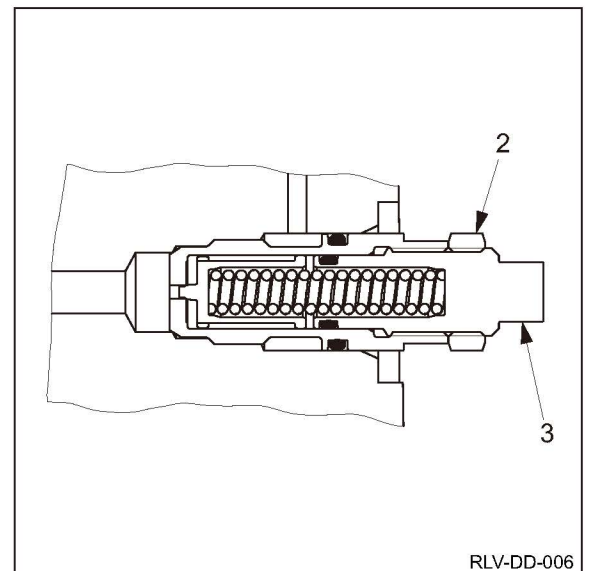
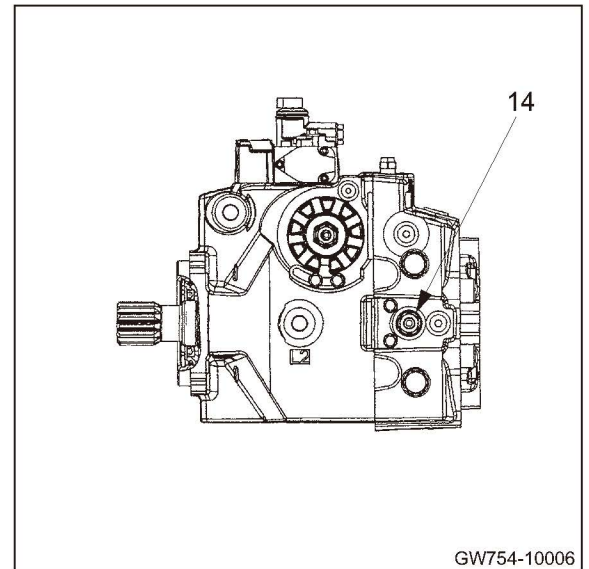

4. MEASUREMENT AND ADJUSTMENT OF PROPULSION SERVO CIRCUIT PRESSURE

4-1. Measurement

- Oil temperature during measurement : $50 \pm 5^{\circ}\text{C}$ ($122 \pm 9^{\circ}\text{F}$)
- ① Disconnect hoses (B) and (C) from servo bypass solenoid valve (A). Attach pressure gauge through adapter (m).
 - Adapter (m) : G1/4
 - Pressure gauge : 0 to 5 MPa (0 to 725 psi)
- ② Confirm that F-R lever is "N".
- ③ Apply parking brake by pressing parking brake switch button.
- ④ Start the engine and set throttle switch to "Full".
- ⑤ Operate F-R lever and then read pressure indicated by pressure gauge.
 - With parking brake applied (ON), measured pressures of (B) and (C) are same.
 - With parking brake released (OFF), measured pressures of (B) and (C) are different.

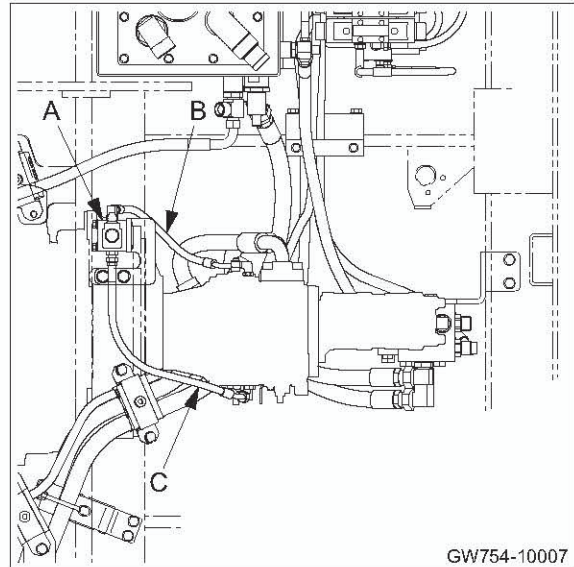

★ Maximum circuit pressure

(pressure limiter valve pressure setting)

: 35 ± 1.0 MPa ($5,075 \pm 145$ psi)

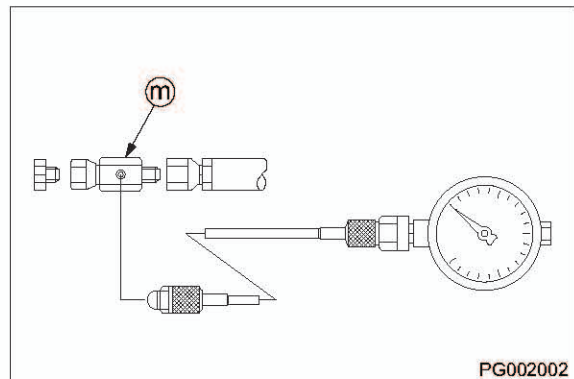

4-2. Adjustment

- If measurement results indicate the pressure deviating from standard maximum circuit pressure range, make an inspection in accordance with procedure described below.

- ① Check nut (a) of pressure limiter valve (2) and (4) for evidence of having loosened.
 - ② If there is evidence of nut having loosened, adjust pressure limiter valve so that pressure becomes within standard pressure limiter valve setting range while watching pressure gauge.
- To adjust pressure, loosen nut and turn adjustment screw (b).

Adjustment screw turned clockwise

: Pressure rise

Adjustment screw turned counterclockwise

: Pressure drop

Pressure change rate : 15 MPa/turn (2,175 psi/turn)

- ③ If there is no evidence of nut having loosened, remove it.
- ④ Check removed pressure limiter valve for trapped dirt and scratches on its seat.
- ⑤ If trapped dirt is present, disassemble and clean pressure limiter valve.
- ⑥ If a scratch is found on seat, replace pressure limiter valve.
- ⑦ After adjustment, measure pressure again and check that pressure reaches maximum circuit pressure range.

- 
- (a) Nut : 20 N·m (15 lbf·ft)
- (2) Pressure limiter valve : 40 N·m (30 lbf·ft)
- (4)

(NOTICE)

- Carefully disassemble and reassemble after taking steps to prevent foreign material from getting in.

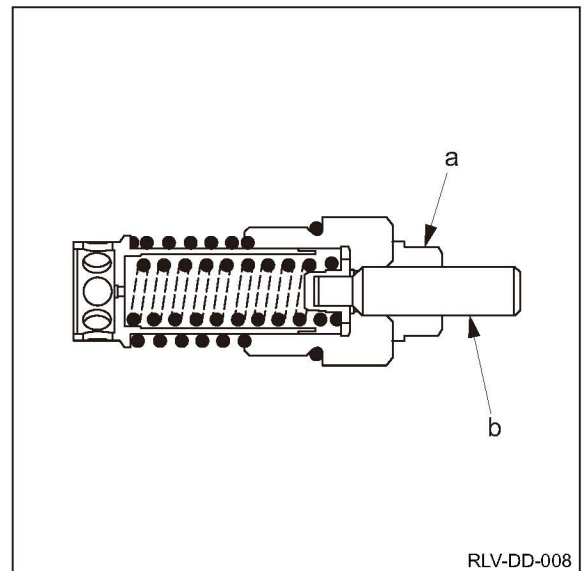
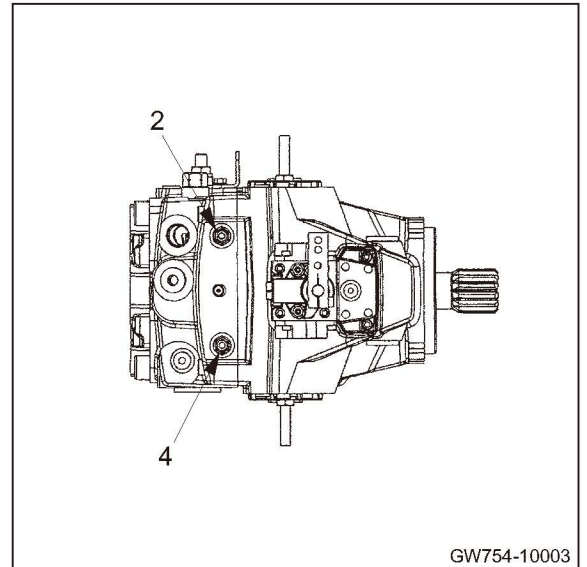

- The number “2” and “4” appearing in above illustrations are consistent with lead line numbers shown in illustration of propulsion hydraulic pump in “2-2. Hydraulic Component Specifications” (P.4-007).

5. MEASUREMENT OF PARKING BRAKE RELEASE PRESSURE

- Since oil in charge circuit is supplied from steering circuit, confirm that steering operation is normal before measurement.

5-1. Measurement

- Oil temperature during measurement : $50 \pm 5^{\circ}\text{C}$ ($122 \pm 9^{\circ}\text{F}$)
- ① Disconnect hose (1) from brake valve. Attach pressure gauge through adapter (m) .
 - Adapter (m) : G1/4
 - Pressure gauge : 0 to 5 MPa (0 to 725 psi)
- ② Confirm that F-R lever is "N".
- ③ Apply parking brake by pressing parking brake switch button.
- ④ Start the engine and set throttle switch to "Full".
- ⑤ Release parking brake by pressing parking brake switch button.
- ⑥ Read brake release pressure indicated by pressure gauge.

★ Brake release pressure

: 1.4 to 3.0 MPa (203 to 435 psi)

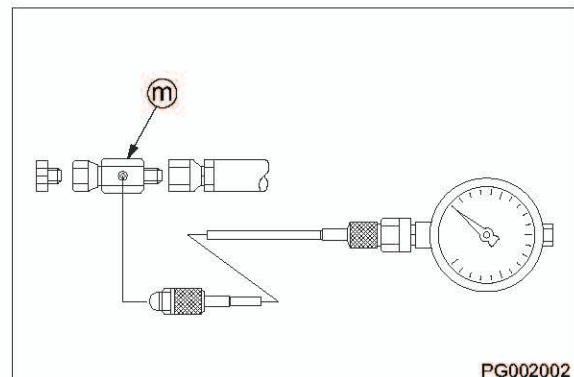
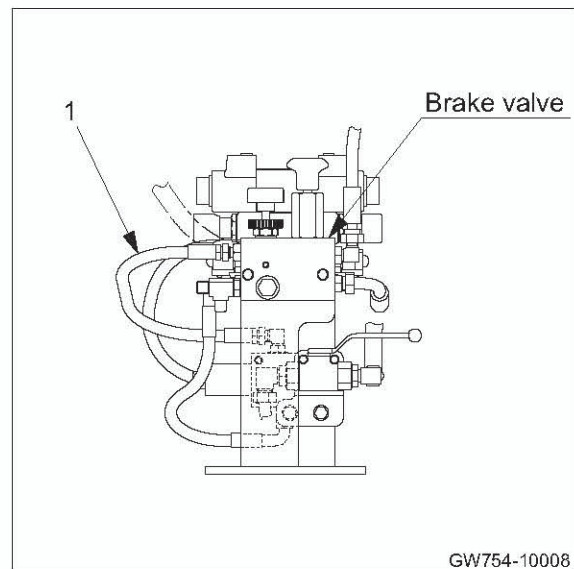

6. MEASUREMENT AND ADJUSTMENT OF VIBRATOR CIRCUIT PRESSURE

6-1. Measurement

⚠ CAUTION

Take care not to operate the vibratory drum for a longer period of time than necessary with the machine stationary. Otherwise, the vibrator bearing could be seized.

- Oil temperature during measurement : $50 \pm 5^{\circ}\text{C}$ ($122 \pm 9^{\circ}\text{F}$)
- ① Remove plugs from gauge port (11) of vibrator solenoid valve (F) or (R). Attach pressure gauge with adapter ⑥.
 - Adapter ⑥ : G1/4
 - Pressure gauge: 0 to 25 MPa (0 to 3,625 psi)
- ② Confirm that F-R lever is "N".
- ③ Apply parking brake by pressing parking brake switch button.
- ④ Set vibration mode select switch to "⚙".
- ⑤ Start the engine and set throttle switch to "Full".
- ⑥ Press F-R lever vibration switch ON.
- ⑦ Slowly move F-R lever to "F" or "R" side.
- ⑧ Read pressure gauge for maximum value of vibrator circuit pressure.
- ⑨ Press F-R lever vibration switch OFF or move back F-R lever to "N" as soon as measurement is finished.

★ Standard relief pressure setting

: $17.2 \pm 1.0 \text{ MPa}$ ($2,494 \pm 145 \text{ psi}$)

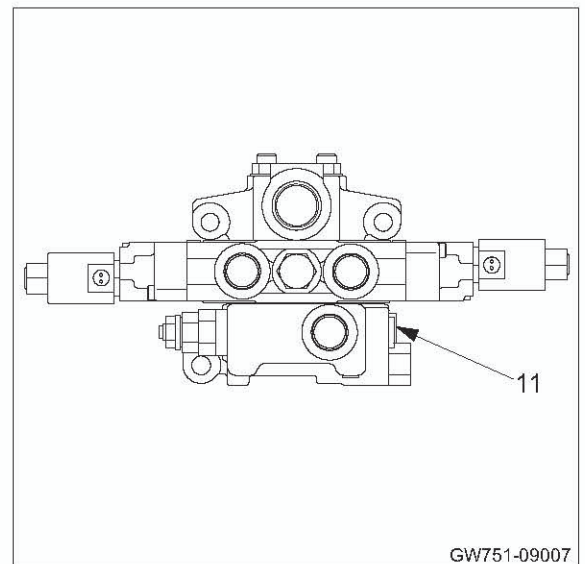

GW751-09007

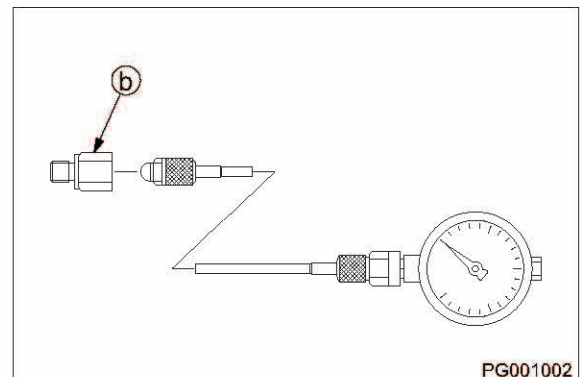

PG001002

- The number "11" appearing in above illustrations is consistent with lead line numbers shown in illustration of vibrator solenoid valve (F), (R) in "3-2-7. Vibrator solenoid valve (F), (R)" (P.4-031).

6-2. Adjustment

- If measurement results indicate the pressure deviating from standard relief pressure range, make an adjustment in accordance with procedure described below.

① Check locknut (2) of relief valve (R1) of vibrator solenoid valve (F) or (R) for evidence of having loosened.

② If there is evidence of locknut having loosened, adjust relief valve so that pressure becomes within standard pressure range while watching pressure gauge.

- To adjust pressure, loosen locknut and turn adjustment screw (1).

Adjustment screw turned clockwise

: Pressure rise

Adjustment screw turned counterclockwise

: Pressure drop

- ③ If there is no evidence of locknut having loosened, remove relief valve.
- ④ Check removed relief valve for trapped dirt and scratches on its seat.
- ⑤ If trapped dirt is present, disassemble and clean relief valve.
- ⑥ If a scratch is found on seat, replace relief valve.
- ⑦ After adjustment, measure pressure again and check that pressure reaches standard pressure range.



(2) Locknut : 15 N·m (11 lbf·ft)
(R1) Relief valve : 90 N·m (66 lbf·ft)

(NOTICE)

- **Carefully disassemble and reassemble after taking steps to prevent foreign material from getting in.**

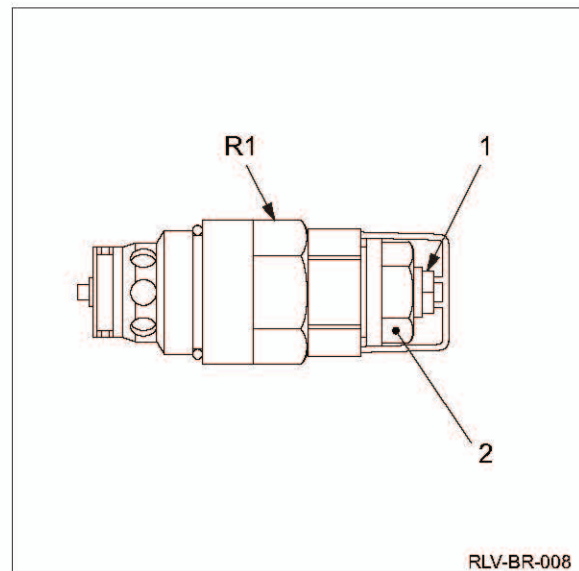
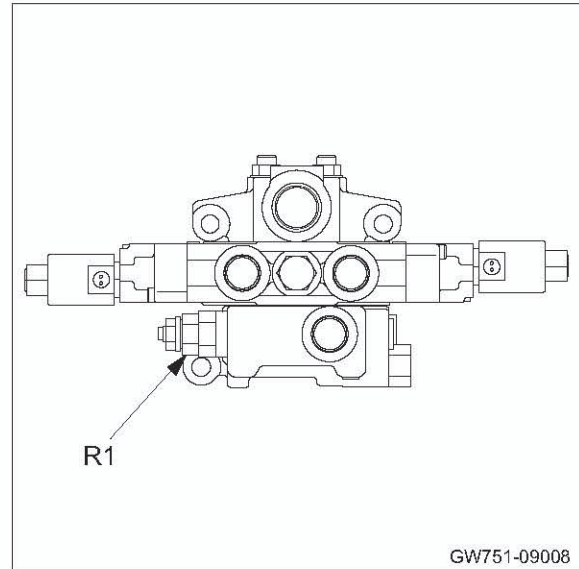

- The "R1" appearing in above illustrations is consistent with lead line number "9" shown in illustration of vibrator solenoid valve (F), (R) in "3-2-7. Vibrator solenoid valve (F), (R)" (P.4-031).

7. MEASUREMENT AND INSPECTION OF STEERING CIRCUIT PRESSURE

7-1. Measurement

⚠ WARNING

Make sure that there is no person around the articulated portion of the machine before operating the steering wheel.

- Oil temperature during measurement : $50 \pm 5^{\circ}\text{C}$ ($122 \pm 9^{\circ}\text{F}$)
- ① Disconnect the hose (1) or (2) from steering cylinder.
Attach pressure gauge through adapter ①.
 - Adapter ① : G3/8
 - Pressure gauge : 0 to 25 MPa (0 to 3,625 psi)
- ② Confirm that F-R lever is "N".
- ③ Apply parking brake by pressing parking brake switch button.
- ④ Start the engine and set throttle switch to "Full".
- ⑤ Turn steering wheel to operate relief valve.
- ⑥ Read pressure indicated by pressure gauge.

★ **Standard maximum circuit pressure**
(orbitroll relief pressure + charge relief pressure)
: $17.4 \pm 1.0 \text{ MPa}$ ($2,523 \pm 145 \text{ psi}$)

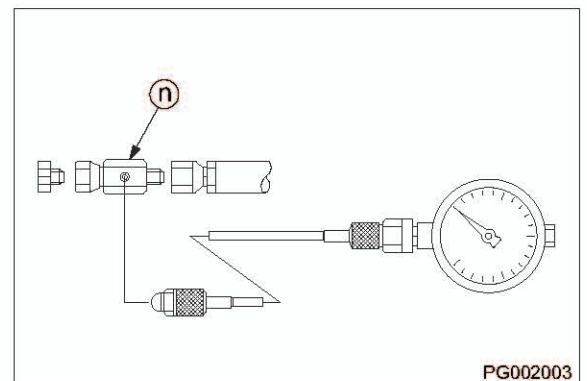
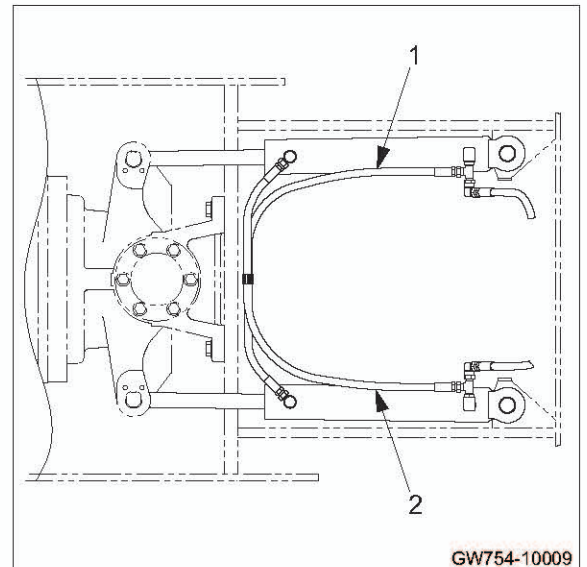

7-2. Inspection

- If measurement results indicate the pressure deviating from standard maximum circuit pressure range, make an adjustment in accordance with procedure described below.

- ① Remove relief valve (3) from orbitrol.
- ② Check removed relief valve for trapped dirt, scratches on its seat and other abnormalities.
- ③ If trapped dirt is present, disassemble and clean relief valve.
- ④ If a scratch or any other abnormality is found on seat, replace relief valve.
- ⑤ After inspection, measure pressure again and check that pressure reaches standard maximum circuit pressure range.

(NOTICE)

- **Carefully disassemble and reassemble after taking steps to prevent foreign material from getting in.**

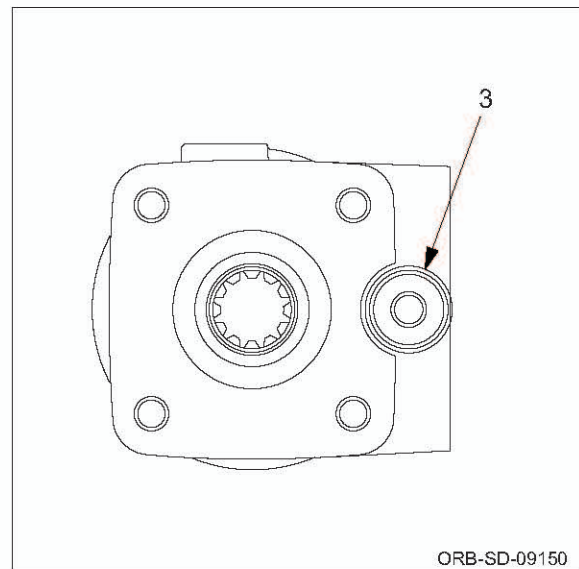

ORB-SD-09150

8. ADJUSTMENT OF F-R LEVER AND SHIFT LEVER

8-1. Adjustment of Linkage

- In cases such as propulsion pump is replaced, control cable is replaced or F-R lever does not move smoothly, make an adjustment in accordance with procedure described below.
- "N", maximum "F", and maximum "R" positions of F-R lever (1) are positioned by notches.

- ① Set F-R lever in "N".
- ② Attach control cable (4) to shaft (2) and dashboard (3).

★ Specified dimension a : 239 mm (9.41 in.)

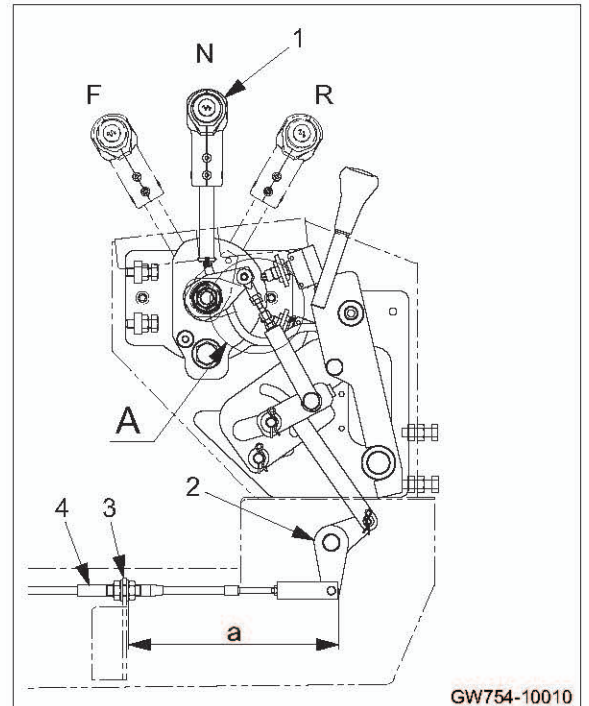

- ③ Attach rod (5) to F-R lever (1) and arm (6).

★ Specified dimension b : 38.5 mm (1.52 in.)

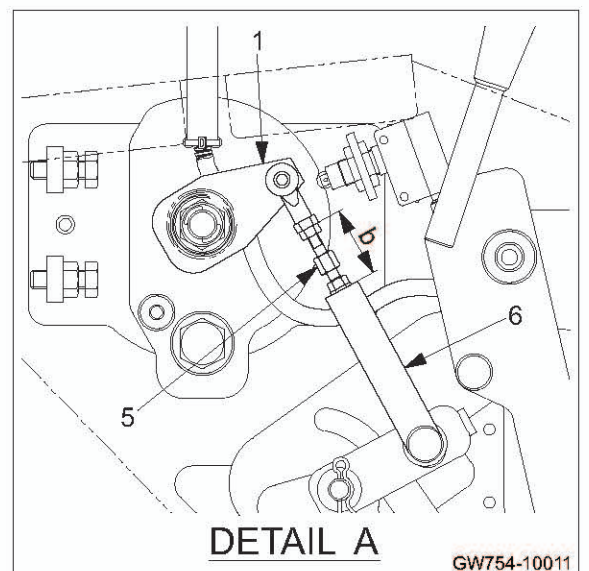

④ Attach control cable (4) to propulsion pump control lever (8) and bracket (7).

★ Specified dimension c : 209 mm (8.23 in.)

⑤ Confirm the strokes of propulsion pump control lever (8).

★ Specified dimension d : Lo 14 mm (0.55 in.)
: Hi 29 mm (1.14 in.)

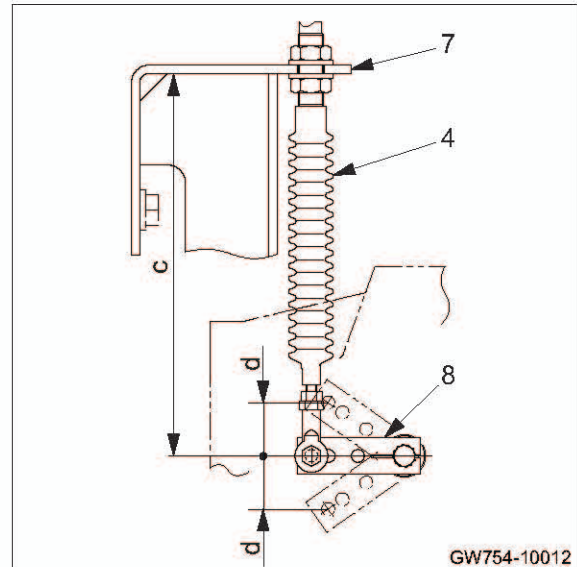

8-2. Adjustment of Operating Force

8-2-1. Adjustment of F-R lever

- ① Adjust nut (9) so that operating force at center of F-R lever (1) knob matches standard operating force.

★ **Standard operating force : 40 ± 10 N (9 ± 2 lbf)**

- ② Loosen lock nut (10), and adjust bolt (11) to match operating force of lever to standard operating force +5N, when getting over notch at center of F-R lever knob.

★ **Operating force to move lever over notch
: 45 ± 10 N (10 ± 2 lbf)**

- After adjustment, fix bolt (11) with lock nut (10).

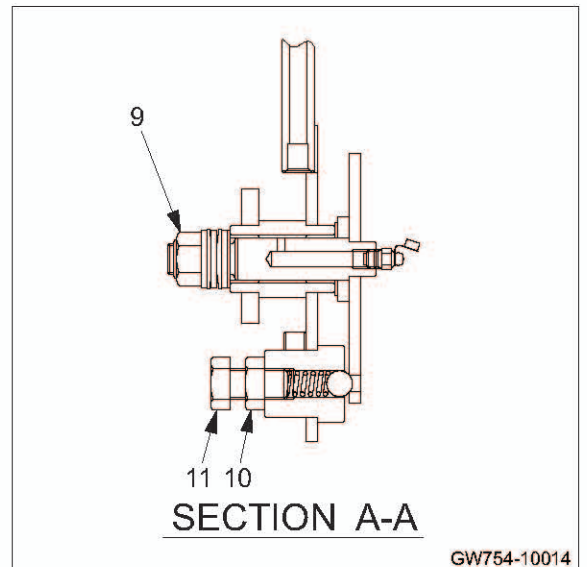
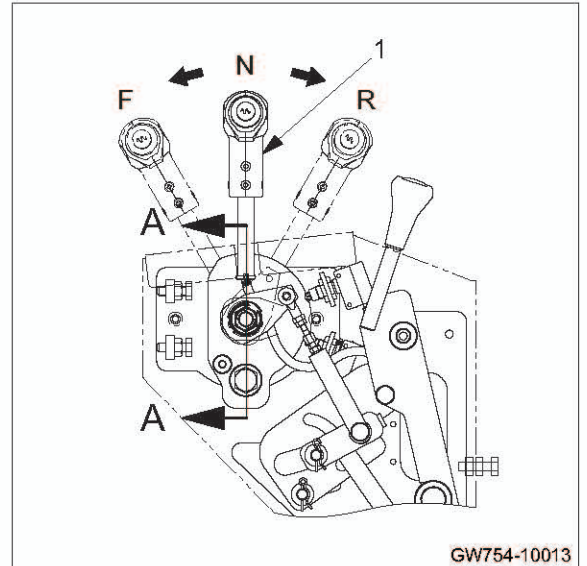

8-2-2. Adjustment of shift lever

- “Lo” and “Hi” positions of shift lever (12) are positioned by notches.

① Adjust nut (15) so that operating force at center of shift lever (12) knob matches standard operating force.

★ **Standard operating force : 40 ± 10 N (9 ± 2 lbf)**

② Loosen lock nut (13), and adjust bolt (14) to match operating force of lever to standard operating force +5N, when getting over notch at center of shift lever knob.

★ **Operating force to move lever over notch
: 45 ± 10 N (10 ± 2 lbf)**

- After adjustment, fix bolt (14) with lock nut (13).

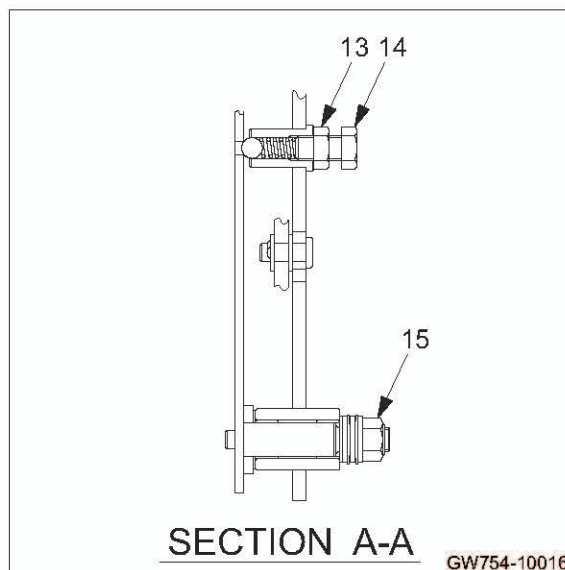
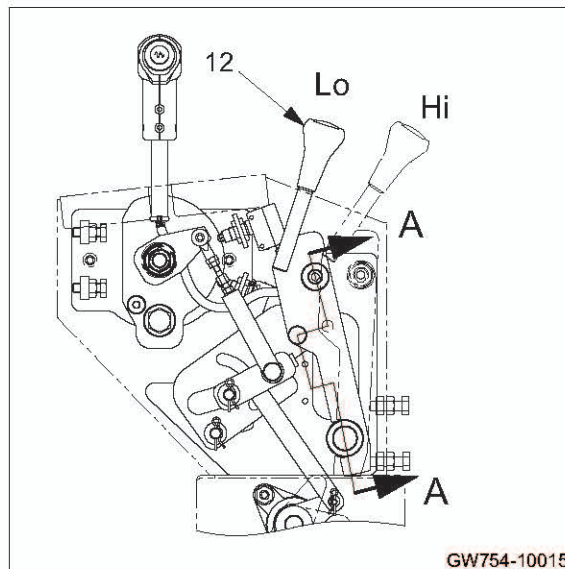

TROUBLESHOOTING

1. TROUBLESHOOTING

1-1. Safety Precautions for Troubleshooting

WARNING

Unexpected machine movement may cause a serious accident. When inspecting the machine while the engine is running, always follow the instructions below.

- Park the machine on level, flat ground.
- Apply the parking brake.
- Set chocks in front and behind each drum or tire.
- Make sure that service personnel are given the appropriate information at the appropriate time.
- Make sure that no one can enter any hazardous area.

CAUTION

Do not work on the hydraulic system while the engine is running and the system is hot and under pressure. Do not disconnect hydraulic hoses or fittings until the system has cooled and pressure has been properly relieved.

Before removing any plugs from the pressure measurement ports, always release any residual pressure from the piping and open the cap of the fluid tank to release and pressure.

WARNING

Inadvertent starting the engine may cause a serious accident.

When inspecting the engine, make sure to exchange the appropriate cues and hand signal with the person at the operator station to avoid any accidents.

CAUTION

Before inspecting inside of the engine compartment, always stop the engine.

Contact with the fan, V-belt or exhaust system parts while the engine is running may cause serious injury.

1-2. Important Information for Troubleshooting

Before conducting troubleshooting, it is important to carefully read the operation manual and workshop manual and understand the electric circuits for each component as well as the structure and function of each system. Sufficient knowledge of the systems will enable you to identify a possible cause much faster. A fault or problem may seem to be related to many different factors. To identify the true cause, some experience is needed. To perform the appropriate troubleshooting, it is important to learn not only the normal operations of the systems but also the possible symptoms that may occur when an abnormal condition is present.

This chapter explains the possible causes and remedies for likely incidents taken from past experience.

1-3. Before Starting

The information in this section is provided to assist the troubleshooter in understanding the systems and quickly determine the causes when operating abnormalities occur.

The following steps are recommended:

1. If not familiar with the machine, study the Operator's Manual and this Shop Manual.
2. Check with the operator for full details of the trouble, ask questions.
3. Verify the trouble by warming up the machine and operating it. Check the problem yourself.
4. Identify the problem with either a mechanical, hydraulic or electrical system source.
5. Isolate the problem to a particular component or circuit.
6. Eliminate the simplest or easiest to check possibilities first to prevent unnecessary disassembly of components.
7. Following repair or replacement of any parts, perform operational tests to verify that the problem has been eliminated and the performance of all the systems is normal.

2. ELECTRICAL SYSTEM TROUBLESHOOTING

2-1. When Performing Electrical System Fault Diagnosis

⚠ WARNING

Be very careful because equipment can return to normal during an inspection and suddenly operate properly when a failure occurs due to a faulty contact or other such cause.

2-1-1. Precautions to take during electrical circuit fault diagnosis

- When disconnecting or connecting a connector, be sure to turn the power supply OFF. (Electronic control parts such as the engine control unit, in particular, could be damaged internally.)
- Since connectors are not numbered, be sure to affix alignment marks so that you can restore them to their original condition.
- Before making a diagnosis, check related connectors for faulty connections. (Check by disconnecting and reconnecting related connectors several times.)
- Before proceeding to the next step, be sure to return the disconnected connectors to their original condition.
- When diagnosing a circuit (measuring the voltage, resistance, continuity and current), move related wiring and connectors several times, and check whether the tester's numerical values change. (If values change, faulty contact in the circuit is possible.)
- Do not ground the circuit of the control unit or apply voltage to it unless otherwise specified.
- For information of wire number, wire size, and wire color used in the sample circuit diagrams, refer to "1-1. Wire Numbers, Wire Sizes, Wire Colors and Connectors Shown in Electrical Circuit Diagram, Wiring Harness Layout and Wiring Harnesses" (P.5-001).

2-1-2. Inspection procedures using a tester

Some of the various inspection procedures are presented here for reference, using a sample circuit below.

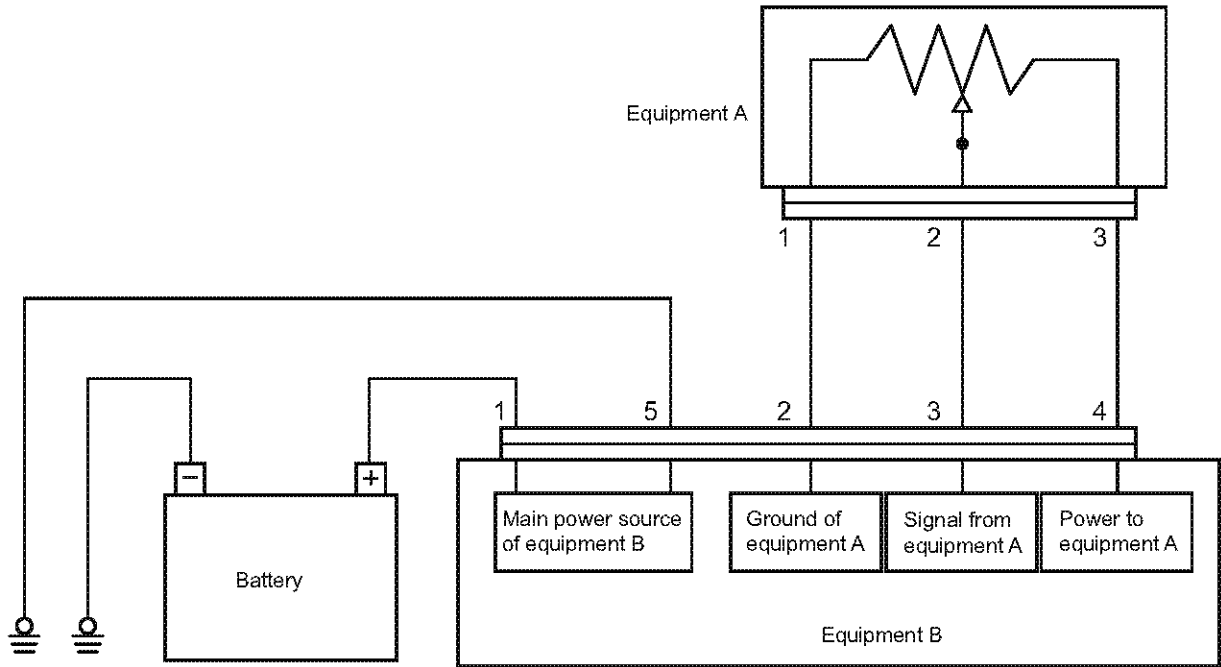

TS-10001

1) Measuring resistance using tester

1-1) Measuring resistance of equipment A (measuring resistance between terminals 1 and 3)

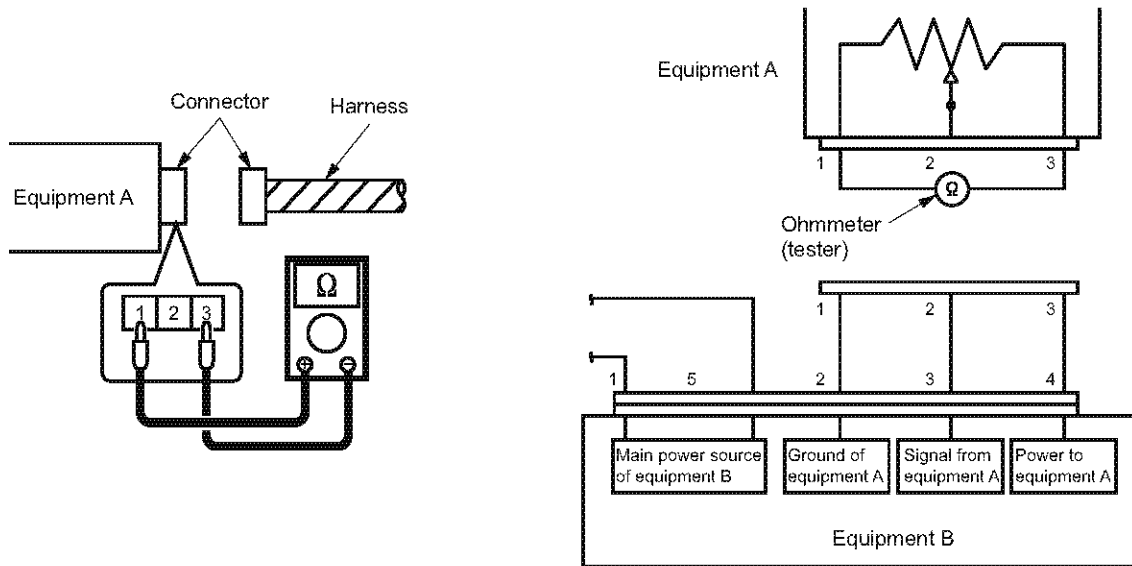

TS-10002

Inspection procedure

- ① Disconnect the connector of equipment A.
- ② Connect the test probe (+) to connector terminal 1 of equipment A and the test probe (-) to connector terminal 3 of equipment A and measure the resistance. At this time, reversing the connector terminals between the probes (+) and (-) does not make any difference in the measurement.

1-2) Measuring resistance of harness (measuring resistance between terminal 1 of equipment A and terminal 2 of equipment B)

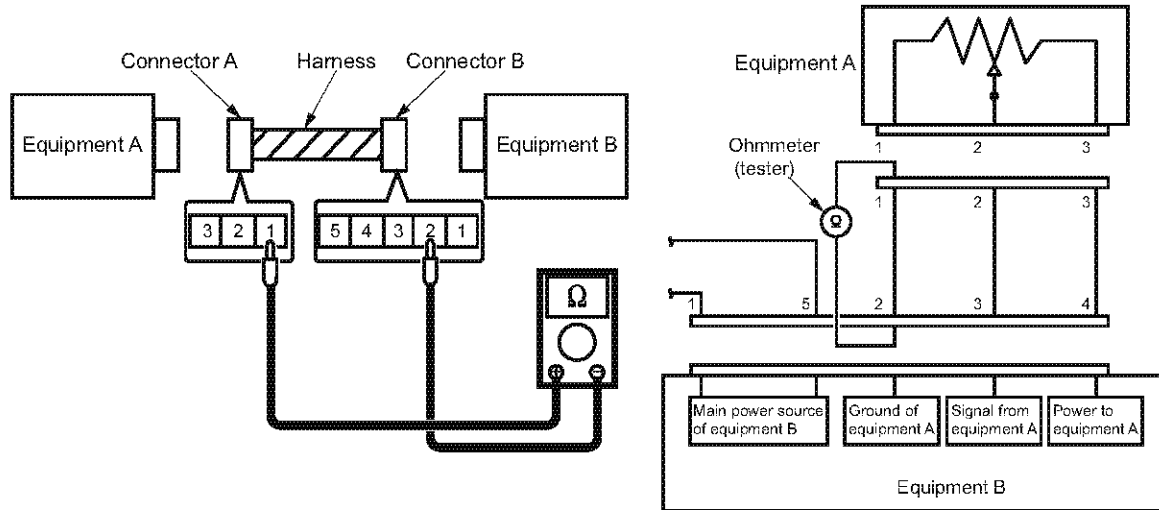

TS-10003

Inspection procedure

- ① Disconnect the connectors of equipment A and equipment B.
- ② Connect the test probe (+) to connector terminal 1 of equipment A and the test probe (-) to connector terminal 2 of equipment B and measure the resistance. At this time, reversing the connector terminals between the probes (+) and (-) does not make any difference in the measurement.

Criteria for harness defects

When there is no abnormality in the harness: Less than 10 Ω (measured value)

If there is any abnormality in the harness such as broken wire: 10 Ω or higher (measured value)

1-3) Measuring resistance of grounding wire (measuring resistance between terminal 5 of equipment B and ground)

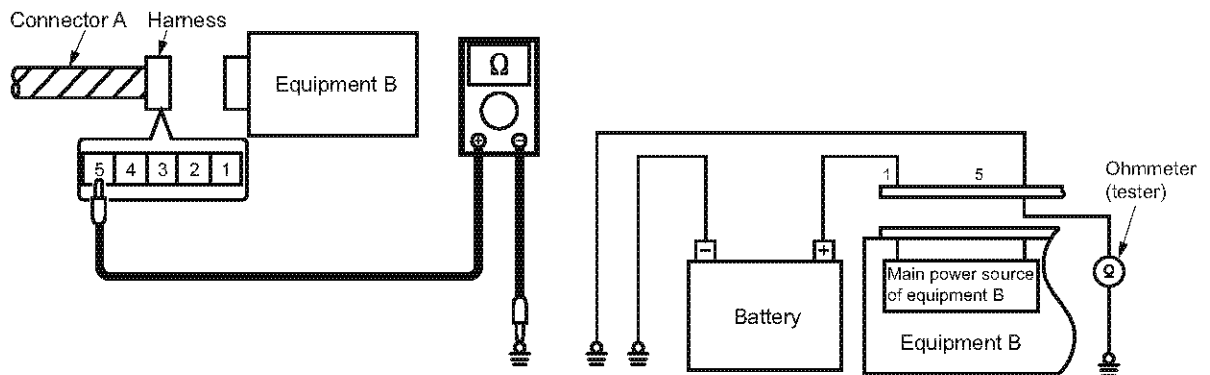

TS-10004

Inspection procedure

- ① Disconnect the connector of equipment B.
- ② Connect the test probe (+) to connector terminal 5 of equipment B and the test probe (-) to a machine ground point (the bolt fastening the ground terminal or an unpainted portion on the body) and measure the resistance. At this time, reversing the connector terminals between the probes (+) and (-) does not make any difference in the measurement.

(NOTICE)

- When measuring the resistance, connect the test probes to both ends of the portion to be measured. Make also sure that no voltage is applied to the portion to be measured.
- When measuring the internal resistance of equipment, be sure first to disconnect all harnesses from the equipment.
- When measuring the resistance of a harness, disconnect the equipment connected to both ends of the harness.

2) Measuring voltage and current flowing using tester

2-1) Measuring voltage of equipment A (measuring voltage between terminals 1 and 3)

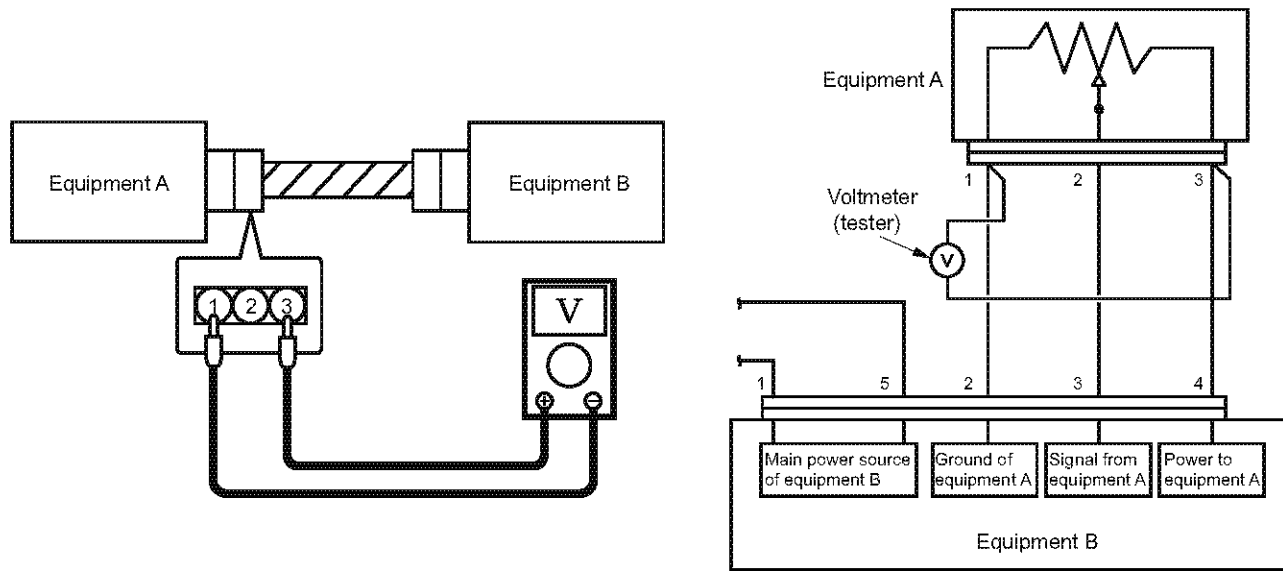

TS-10005

Inspection procedure

- ① Connect the connectors of equipment A and that of equipment B.
- ② Connect the test probe (+) to connector terminal 3 of equipment A and the test probe (-) to connector terminal 1 of equipment A and measure the voltage. Note that reversing the connector terminals between the probes (+) and (-) changes the result of the measurement. Be sure to connect the probe (+) to the power source side and the probe (-) to the ground side.

• Measurement using a test harness

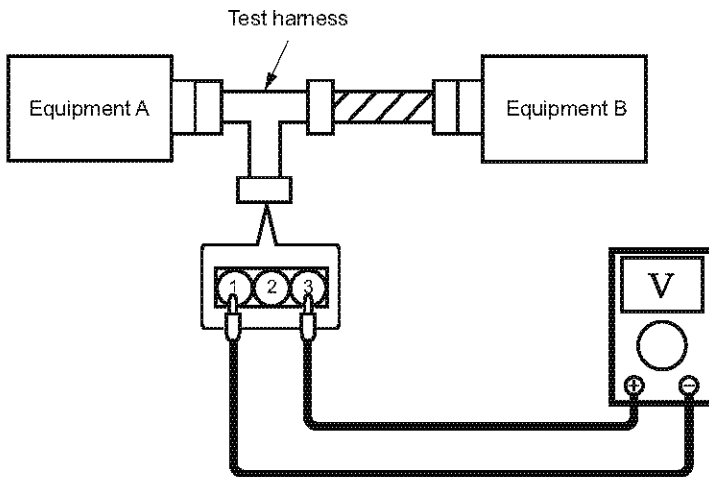

• Measurement from the backside of connector

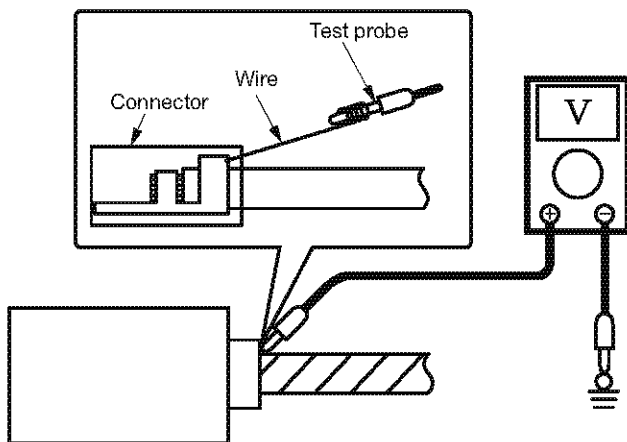

• Measurement on a lead cable

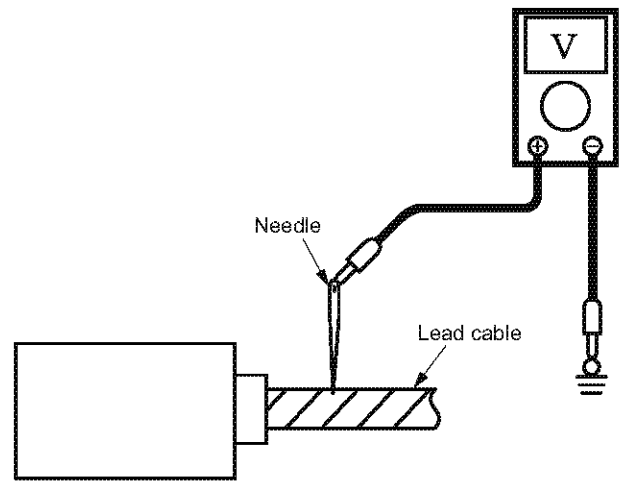

TS-10006

Measurement method

For measurement of voltage, connect the tester probes in parallel to the portion to be measured. Because the voltage can be measured only when the connector is connected in position, contact the tester probes to the terminals without disconnecting the connector. The following methods are available:

- Measurement using a test harness
Prepare the test harness for the measurement.
- Measurement from the backside of connector
Insert a wire from the backside of the connector.
- Measurement on a lead cable
Remove the bundling tape from the harness to separate each cable, and stick the needle into the relevant cable.

(NOTICE)

- **Except for preparing the test harness, proper protection must be made after the measurement to prevent corrosion in the connector terminals or harnesses.**

- 2-2) Measuring current flowing from equipment B to equipment A
(measuring current between terminal 2 of equipment B and terminal 1 of equipment A)

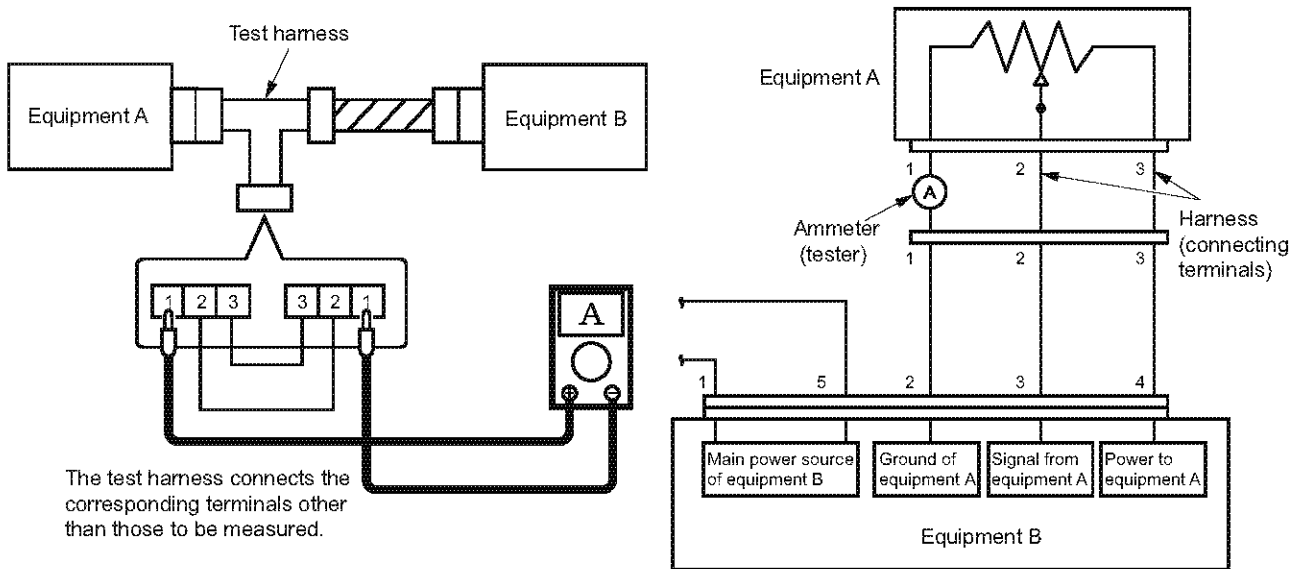

TS-10007

Inspection procedure

- ① Disconnect the connector of equipment A and connect the test harness.
- ② Connect the test probe (+) to connector terminal 1 (harness side) of equipment A and the test probe (-) to connector terminal 1 (equipment side) of equipment A and measure the current. Note that reversing the connector terminals between the probes (+) and (-) changes the result of the measurement. Be sure to connect the probe (+) to the power source side and the probe (-) to the ground side.

Measurement method

When measuring the current, connect the tester in series to the portion to be measured. Because the current cannot be measured when the connector is connected in position, disconnect the connector to allow the test probe to connect between the terminals.

2-1-3. Inspection of electrical system

Operate the applicable switches and turn the relays ON and OFF. Ultimately, if the solenoid valve operates (makes a sound) and the pump runs, the electrical system is OK.

If there is a failure (fault), narrow the range of the inspection to the six broad steps described below.

1) Ground inspection

- Check for disconnected or loose ground. If rust or corrosion is present (which can cause faulty contact), remove the rust.

2) Fuse inspection

2-1) Check for blown fuses, disconnections and corrosion. (A fatigue open circuit cannot be identified visually. Use a tester for checking.)

2-2) If a fuse is blown

Check whether a pump or valve (that is supposed to be protected by a blown fuse) burned, and whether there is a burning odor.

Especially if the pump and valve are not burned, check the harness for signs of burning. If it is burned, replace it.

If a fuse is blown and a relay along the pathway has failed, replace it. And if there is a timer, replace the timer, too. If a switch visually appears to be unsatisfactory (burned, melted, etc.) even though it operates, replace it.

- Simply replacing a fuse may not eliminate the true cause of a problem, and over current may flow again. Also, if over current secondarily causes an electrical path to fail (such as a wiring meltdown inside a solenoid valve), current will not flow. Thus, a fuse may not be blown out, but it also will not operate. If you do not know the location of burning or of an odor, investigate as described follows.

2-3) How to find cause of failure when fuse blown is reproduced

- ① Turn the starter switch OFF, and remove the connector from the load (valve, pump).
- ② Referring to the circuit diagram, remove electrical parts that are connected to the circuit, such as relays, timers and diodes.
- ③ Turn the starter switch ON, and see whether the conditions can be reproduced (fuse is blown).
- ④ If a fuse is blown, a part such as a relay may have caused a short between the previous harness and ground (vehicle body). (Replace the harness.) If the conditions are not reproduced, check for signs of burning (odor) on the removed electrical parts.
- ⑤ If there is no problem, turn the starter switch OFF and reattach the parts.
- ⑥ Turn the starter switch ON and try again.
- ⑦ If a fuse is blown with this action, the problem was caused by a short between the harness and ground (vehicle body) that followed the attached electrical part. (Replace the harness.)
- ⑧ If the conditions are not reproduced, turn the starter switch OFF, and connect the loads (valve and pump) one at a time. Turn the starter switch ON and try again to see whether the fuse blown is reproduced.
- ⑨ If the fuse blown is reproduced, whatever was added at that time (including a harness added electrically) will be the cause of the failure.
 - Even if the fuse is not blown and the valve or pump is not burned, the valve or pump may be damaged electrically and may not operate. There may simply be a disconnection in the interior or an abnormal heat-up.
 - Even if the fuse is not blown, abnormal heat-up (hot enough to cause burns if touched) may occur if a relay, timer, diode or other semiconductor fails.

3) Connector inspection

- Is a connector disconnected or loose?
- Check that pins are not snapped or corroded.
- If faulty contact is suspected

Turn the starter switch OFF. Then disconnect and check the connectors (including relay and switch sockets).

If the terminal has no luster, faulty contact due to oxidation can be suspected. Therefore, polish the terminal by inserting and removing the connector (relay, switch) repeatedly at least five times. (Luster will return.)

4) Relay inspection (Check ON/OFF operation by sound.)

- Conduct without running the engine. (If you run the engine, you cannot hear the sound of operation.)

Sound heard : A relay failure occurred.

No sound heard : Using a tester, check the harness.

Sound heard : A relay failure occurred.

Still no sound : Using a tester, check the harness.

Continuity : Turn the starter switch OFF temporarily, disconnect the relay and check for continuity between the harness-side grounding terminal (color: black) and vehicle body ground. (If there is none, replace the harness.)

Voltage : With the relay disconnected, turn the starter switch ON and turn the operating switch ON. 24 V (or 12 V) (between vehicle body ground) should not reach the relay coil input terminal. Confirm this. Identify the location (section) to which 24 V (or 12 V) reaches. Then replace the harness or take other action.

5) Solenoid valve inspection (Check ON/OFF operation by sound.)

- Conduct without running the engine. (If you run the engine, you cannot hear the sound of operation.)

Sound heard : The electrical system is normal.

No sound heard : Check with a tester.

Continuity : ① Turn the starter switch OFF temporarily, disconnect the connector and check for continuity between the harness-side grounding terminal (color: black) and vehicle body ground. (If there is none, replace the harness.)

: ② Is the solenoid valve coil burnt?

(Turn the starter switch OFF, disconnect the connector and check the resistance between the solenoid valve terminals.)

Voltage : With the connector disconnected, turn the starter switch ON and check whether 24 V (or 12 V) exists between the harness-side connector and vehicle body ground.

If YES : Replace the valve.

If NO : Investigate and identify the location (section) to which 24 V (or 12 V) reaches. Then replace the harness or take other action.

6) Harness check

- If an incomplete disconnection inside the harness is suspected, wiggle (move) the harness during the relay inspection and solenoid valve inspection to see whether the relay (valve) operates incorrectly.
- Check for burned areas of the harness.
- Turn the starter switch OFF, disconnect the connector and check the continuity, referring to the circuit diagram and wiring coloring.

2-2. Engine Diagnosis Trouble Code

2-2-1. Description of fault code (SPN, FMI)

- When a fault code (SPN,FMI) occurs, display a fault code on the display monitor.

Display monitor

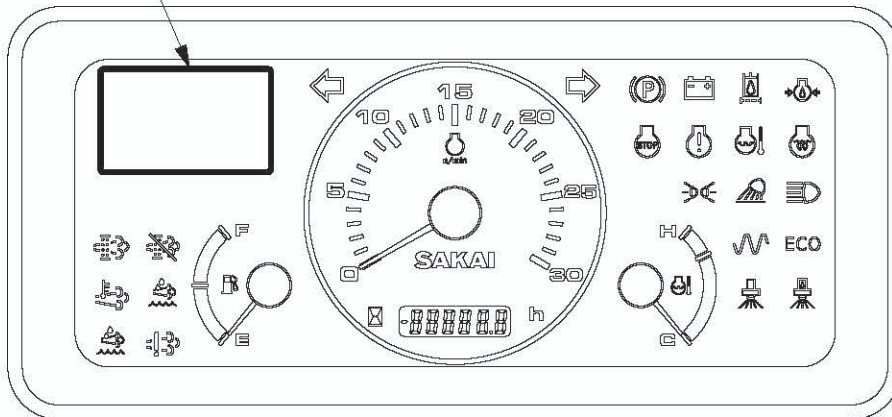

SV544-09001

- Fault codes can be accessed in at least two different ways; using the electronic service tool or a method of displaying it on a display monitor in a combination meter.
- How to check the fault code occurring in the electronic fuel system / protection system of the engine on the display monitor.
 - Set the start switch to "ON".
 - Hold the diagnostic switch in the "DIAG." Position.

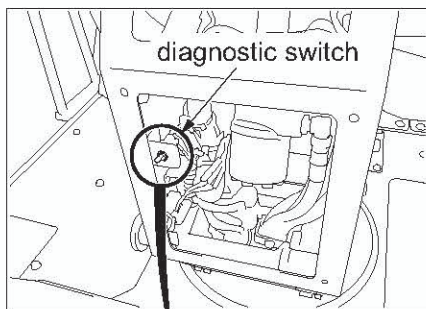

Self-diagnosis in progress.

Wait to start

No fault code.

DTC MESSAGE : 0 OF 0
 SPN : ____
 FMI : __
 SA : __

Occurrence of fault code.

DTC MESSAGE : 4 OF 5
 SPN : 32
 FMI : 24
 SA : 1

SW774-11001

2-2-2. Fault code list (SPN, FMI)

J1939-73		Description	DTC Description	Diagnosis
SPN	FMI			
29	3	Accelerator pedal or lever position sensor-2 abnormal	Accelerator sensor-2 High	• Short circuit in sensor/harness power supply
	4		Accelerator sensor-2 Low	• Open circuit in sensor/harness, ground fault
91	2	Accelerator pedal or lever position sensor property abnormal	Accelerator pedal sensor property abnormal	• Sensor output of two systems excessively different
	3	Accelerator pedal or lever position sensor-1 abnormal	Accelerator sensor-1 High	• Short circuit in sensor/harness power supply
	4		Accelerator sensor-1 Low	• Open circuit in sensor/harness, ground fault
100	1	Oil pressure decrease	Engine oil pressure decrease	• Engine oil pressure switch activated
102	3	Boost pressure sensor abnormal	Boost pressure sensor High	• Open circuit in sensor/harness, +B short-circuited • Sensor failure
	4		Boost pressure sensor Low	• Short circuit in sensor/harness ground • Sensor failure
108	3	Atmospheric pressure sensor abnormal	Atmospheric pressure sensor High	• Short circuit in sensor/ECU internal circuit +B
	4		Atmospheric pressure sensor Low	• Short circuit in sensor/ECU internal circuit ground
110	0	Overheat	Engine overheat	• Engine water temperature abnormally high
	3	Water temperature sensor abnormal	Water temperature sensor High	• Open circuit in sensor/harness, +B short-circuited
	4		Water temperature sensor Low	• Short circuit in sensor/harness ground
132	1	Intake air shortage (Turbo blower IN hose disconnected)	Intake air shortage (Turbo blower IN hose disconnected)	• Intake air shortage (Turbo blower IN hose disconnected)
	3	Mass air flow (MAF) sensor abnormal	Mass air flow (MAF) sensor High	• Short circuit in sensor/harness +B
	4		Mass air flow (MAF) sensor Low	• Open circuit in sensor/harness, ground fault
	15	Turbo boost increase insufficient (Blow out: Hose between intake flanges disconnected)	Turbo boost increase insufficient (Blow out: Hose between intake flanges disconnected)	• Turbo blow out: Hose between intake flanges disconnected (abnormal)

J1939-73		Description	DTC Description	Diagnosis
SPN	FMI			
157	0	Rail pressure abnormally high	Rail pressure abnormally high	<ul style="list-style-type: none"> Actual pressure exceeds command pressure. (When detected high pressure exceeding specified pressure range)
	1	Rail pressure too low	Rail pressure too low	<ul style="list-style-type: none"> Rail pressure too low (Negative pressure at the Inlet of supply pump is high and supply pump delivery system error, ex filter clogging, air entrainment)
	2	Common Rail Pressure Sensor Signal keeping a middle range	Common Rail Pressure Sensor Signal keeping a middle range	<ul style="list-style-type: none"> Common Rail Pressure Sensor Signal keeping a middle range
	3	Rail pressure sensor abnormal	Rail pressure sensor High	<ul style="list-style-type: none"> Open circuit in sensor/harness, +B short-circuited Sensor failure
	4		Rail pressure sensor Low	<ul style="list-style-type: none"> Short circuit in sensor/harness ground Sensor failure
168	3	Battery voltage abnormal	Battery voltage High	<ul style="list-style-type: none"> Open circuit, short circuit, or breakage in harness Battery abnormal
	4		Battery voltage Low	<ul style="list-style-type: none"> Open circuit, short circuit, or breakage in harness Battery abnormal
171	3	Intake air temperature sensor (with built-in mass air flow sensor) abnormal	Intake air temperature sensor (with built-in mass air flow sensor) High	<ul style="list-style-type: none"> Open circuit in sensor/harness, +B short-circuited
	4		Intake air temperature sensor (with built-in mass air flow sensor) Low	<ul style="list-style-type: none"> Short circuit in sensor/harness ground
172	0	Intake air temperature abnormally high (Intercooler model only)	Intake air temperature abnormally high	<ul style="list-style-type: none"> Intake air temperature abnormally high
	3	Intake air temperature sensor abnormal	Intake air temperature sensor High	<ul style="list-style-type: none"> Open circuit in sensor/harness, +B short-circuited
	4		Intake air temperature sensor Low	<ul style="list-style-type: none"> Short circuit in sensor/harness ground
190	0	Overrun	Engine overrun	<ul style="list-style-type: none"> Engine speed exceeds specified speed
628	2	ECU FLASH ROM and CPU abnormality	ECU FLASH ROM error	<ul style="list-style-type: none"> FLASH ROM error
			SUB CPU (Monitoring IC) FLASH ROM error	<ul style="list-style-type: none"> FLASH ROM of monitoring IC error
636	2	Crankshaft position sensor (NE sensor) abnormal	NE sensor pulse count abnormal	<ul style="list-style-type: none"> Open circuit in sensor/harness, short-circuited Sensor failure
	7	NE-G phase shift	NE-G phase shift failure	<ul style="list-style-type: none"> Phase shift between NE pulse and G pulse excessive
	8	Crankshaft position sensor (NE sensor) abnormal	NE sensor pulse not inputted	<ul style="list-style-type: none"> Open circuit in sensor/harness, short-circuited Sensor failure

J1939-73		Description	DTC Description	Diagnosis
SPN	FMI			
645	3	Engine tachometer signal output error	Tachometer pulse output error	<ul style="list-style-type: none"> +B short of pulse driving circuit when tachometer pulse output is activated
651	3	Open circuit in TWV driving system	Injector of 1st engine cylinder (TWW1): Open circuit in harness/coil	<ul style="list-style-type: none"> Open circuit in harness Open circuit in injector coi
	6	Coil short in injector	Coil short in 1st cylinder injector	<ul style="list-style-type: none"> Injector coil short (over current)
	8	TWW driving circuit error	TWW1 driving circuit error	<ul style="list-style-type: none"> Open circuit of discharge MOS-IC in ECU
652	3	Open circuit in TWV driving system	Injector of 2nd engine cylinder (TWW4): Open circuit in harness/coil	<ul style="list-style-type: none"> Open circuit in harness Open circuit in injector coi
	6	Coil short in injector	Coil short in 2nd cylinder injector	<ul style="list-style-type: none"> Injector coil short (over current)
	8	TWW driving circuit error	TWW4 driving circuit error	<ul style="list-style-type: none"> Open circuit of discharge MOS-IC in ECU
653	3	Open circuit in TWV driving system	Injector of 3rd engine cylinder (TWW2): Open circuit in harness/coil	<ul style="list-style-type: none"> Open circuit in harness Open circuit in injector coi
	6	Coil short in injector	Coil short in 3rd cylinder injector	<ul style="list-style-type: none"> Injector coil short (over current)
	8	TWW driving circuit error	TWW2 driving circuit error	<ul style="list-style-type: none"> Open circuit of discharge MOS-IC in ECU
654	3	Open circuit in TWV driving system	Injector of 4th engine cylinder (TWW3): Open circuit in harness/coil	<ul style="list-style-type: none"> Open circuit in harness Open circuit in injector coi
	6	Coil short in injector	Coil short in 4th cylinder injector	<ul style="list-style-type: none"> Injector coil short (over current)
	8	TWW driving circuit error	TWW3 driving circuit error	<ul style="list-style-type: none"> Open circuit of discharge MOS-IC in ECU
675	3	Heater Lamp error	Heater Lamp error	<ul style="list-style-type: none"> +B short of lamp driving circuit when lamp is on
677	3	Starter relay driving error	Starter relay driving error	<ul style="list-style-type: none"> +B short of relay driving circuit when relay is on
723	2	Camshaft position sensor (G sensor) abnormal	G sensor pulse count abnormal	<ul style="list-style-type: none"> Open circuit in sensor/harness, short-circuited Sensor failure
	8		G sensor pulse not inputted	
1077	2	ECU flash ROM and CPU abnormal	ECU CPU abnormal (main IC abnormal)	<ul style="list-style-type: none"> CPU failure
1239	1	Fuel leakage (high pressure fuel system)	Fuel leakage (high pressure fuel system)	<ul style="list-style-type: none"> Fuel leakage from high pressure fuel system (when detected excessive fuel consumption, calculating from difference of fuel rail pressure before and after fuel injection)

J1939-73		Description	DTC Description	Diagnosis
SPN	FMI			
3242	0	Exhaust temperature rise abnormal T1	Exhaust temperature rise abnormal T1	• DPF inlet temperature (T1) abnormally high
	3	Exhaust temperature sensor 1 (T1: DOC outlet) abnormal	Exhaust temperature sensor 1 (T1: DOC outlet) High	• Open circuit in sensor/harness, +B short-circuited
	4		Exhaust temperature sensor 1 (T1: DOC outlet) Low	• Short circuit in sensor/harness ground
3246	0	Exhaust temperature rise abnormal T2	Exhaust temperature rise abnormal T2	• DPF outlet temperature (T2) abnormally high
	3	Exhaust temperature sensor 2 (T2: DPF outlet) abnormal	Exhaust temperature sensor 2 (T2: DPF outlet) High	• Open circuit in sensor/harness, +B short-circuited
	4		Exhaust temperature sensor 2 (T2: DPF outlet) Low	• Short circuit in sensor/harness ground
3251	3	Differential pressure sensor abnormal	Differential pressure sensor abnormal High	• Open circuit in sensor/harness, +B short-circuited
	4		Differential pressure sensor abnormal Low	• Short circuit in sensor/harness ground
3252	0	DOC reaction abnormal (exhaust gas abnormal)	DOC reaction abnormal (exhaust gas abnormal)	• DOC temperature abnormally high due to unburned gas
3509	3	Sensor voltage 1 abnormal	Sensor supply voltage 1 High	• Sensor supply voltage 1 abnormal or recognition abnormal
	4		Sensor supply voltage 1 Low	
3510	3	Sensor supply voltage 2 abnormal	Sensor supply voltage 2 High	• Sensor supply voltage 2 abnormal or recognition abnormal
	4		Sensor supply voltage 2 Low	
3697	3	Lamp driving circuit error	Parked regeneration request Lamp error	• +B short of lamp driving circuit when lamp is on
3701	0	PM accumulation abnormal level 5	PM accumulation abnormal level 5	• PM (estimated) accumulation quantity excessive level 5
	15	PM accumulation abnormal level 3	PM accumulation abnormal level 3	• PM (estimated) accumulation quantity excessive level 3
	16	PM accumulation abnormal level 4	PM accumulation abnormal level 4	• PM (estimated) accumulation quantity excessive level 4
3702	13	Regeneration inhibit request reception (Not DTC)	Regeneration inhibit request reception (Not DTC)	• Regeneration inhibit request from ACU
4115	3	Lamp driving circuit error	Engine warning Lamp error	• +B short of lamp driving circuit when lamp is on
4765	0	Exhaust temperature rise abnormal T0	Exhaust temperature rise abnormal T0	• DOC inlet temperature (T0) abnormally high
	3	Exhaust temperature sensor 0 (T0 : DOC inlet) abnormal	Exhaust temperature sensor 0 (T0 : DOC inlet) High	• Open circuit in sensor/harness, +B short-circuited
	4		Exhaust temperature sensor 0 (T0 : DOC inlet) Low	• Short circuit in sensor/harness ground

J1939-73		Description	DTC Description	Diagnosis
SPN	FMI			
523523	2	Open circuit in common 1 system	Open circuit in injector driving circuit: Common 1 system, or TWV 1 and 3 (1st and 4th cylinders) simultaneously	• Open circuit in harness
	3	Short circuit in common 1 TWV driving system	Short circuit in battery: Injector driving circuit at ECU side (Common 1 system), or 1st and 4th cylinders at INJ side simultaneously	• Short circuit in harness +B
	4		Short circuit in GND: Injector driving circuit at ECU side (Common 1 system), or 1st and 4th cylinders at INJ side simultaneously	• Short circuit in harness ground
523524	2	Open circuit in common 2 system	Open circuit in injector driving circuit: Common 2 system, or TWV 2 and 4 (3rd and 2nd cylinders) simultaneously	• Open circuit in harness
	3	Short circuit in common 2 TWV driving system	Short circuit in battery: Injector driving circuit at ECU side (Common 2 system), or 2nd and 3rd cylinders at INJ side simultaneously	• Short circuit in harness +B
	4		Short circuit in GND: Injector driving circuit at ECU side (Common 2 system), or 2nd and 3rd cylinders at INJ side simultaneously	• Short circuit in harness ground
523525	1	Injector charge voltage abnormal	ECU injector charge voltage insufficient	• Injector charge voltage insufficient • ECU charge circuit failure
523527	2	ECU flash ROM and CPU abnormal	ECU CPU abnormal (watching IC abnormal)	• CPU-watching IC failure
523535	0	Overcharge	ECU injector charge voltage excessively high	• ECU injector charge voltage excessively high (ECU charge circuit failure)
523538	2	QR abnormal	QR data abnormal	• QR code correction data abnormal
	7		QR data writing abnormal	• QR code correction data unwritten
523539	2	Pump seizure	Pump seizure 1	• Pressure abnormally high 1
523540	2		Pump seizure 2	• Pressure abnormally high 2
523543	2	Accelerator pedal or lever position sensor abnormal (via CAN)	Accelerator sensor at machine body abnormal	• Abnormal message from machine body received
523544	3	Air heater relay drive abnormal	Short circuit in air heater relay driving circuit +B	• Short circuit in air heater relay driving circuit +B
	4		Short circuit in air heater relay driving circuit GND	• Open circuit in air heater relay driving circuit, ground fault
523547	2	CAN2 bus off	CAN2 bus off	• Short circuit in CAN2 +B/GND or traffic abnormally high

J1939-73		Description	DTC Description	Diagnosis
SPN	FMI			
523548	2	Open circuit in CAN2 frame	Open circuit in CAN_KBT original frame	• Open circuit in CAN_KBT original frame
523572	4	EGR motor abnormal	EGR position sensor abnormal	• EGR position sensor abnormal
523574	3		Open circuit in EGR motor	• Open circuit in EGR motor coil
	4		Short circuit in EGR motor	• Short circuit in EGR motor coil
523575	7	EGR (DC motor) abnormal	EGR valve sticking (FB abnormal)	• EGR valve sticking
523576	2		EGR motor ambient temperature abnormal	• EGR motor temperature abnormally high
523577	2		EGR thermistor sensor with built-in valve abnormal	• EGR motor temperature sensor abnormal
523578	2	Open circuit in CAN_ EGR control line	Disconnection (open circuit) in EGR control line communication	• CAN communication with EGR
523580	2	Intake throttle FB (feed back) abnormal	Intake throttle FB (feed back) abnormal	• Intake throttle DC motor feed back abnormal
523582	3	Intake throttle lift sensor abnormal	Intake throttle lift sensor abnormal (High)	• Intake throttle lift sensor High
	4		Intake throttle lift sensor abnormal (Low)	• Intake throttle lift sensor Low
523589	17	Water temperature rise during manual regeneration insufficient	Water temperature rise during manual regeneration insufficient	• While regenerating, conditions required for warming up the engine not established (Insufficient water temperature rise)
523590	16	Manual regeneration process time-up abnormal	Manual regeneration process time-up abnormal	• Regeneration process not end due to insufficient DPF temperature rise (Regeneration time)
523591	2	Open circuit in CAN2 frame	CAN_CCVS communication disruption	• CAN_CCVS communication disruption
523592	2		CAN_CM1 communication disruption	• CAN_CM1 communication disruption
523593	2		CAN_DDC1 communication disruption	• CAN_DDC1 communication disruption
523594	2		CAN_ETC2 communication disruption	• CAN_ETC2 communication disruption
523595	2		CAN_ETC5 communication disruption	• CAN_ETC5 communication disruption
523596	2		CAN_TSC1 communication disruption	• CAN_TSC1 communication disruption
523598	2		CAN_EBC1 communication disruption	• CAN_EBC1 communication disruption
523599	0	Simultaneous open circuit in all exhaust temperature sensors	Simultaneous open circuit in all exhaust temperature sensors	• Simultaneous open circuit in all exhaust temperature sensors
523600	0	Warning on incomplete learning of individual difference of pumps	Warning on incomplete learning of individual difference of pumps	• Pump learning history

J1939-73		Description	DTC Description	Diagnosis
SPN	FMI			
523601	0	Exhaust temperature continuously abnormal (Starter relay drive prohibit warning)	Exhaust temperature continuously abnormal (Starter relay drive prohibit warning)	<ul style="list-style-type: none"> Exhaust temperature when abnormally high temperature generated
523602	0	Regeneration frequency abnormally high	Regeneration frequency abnormally high	<ul style="list-style-type: none"> Abnormal interval between end of regeneration process and trigger for next regeneration
523603	15	Warning on High. Temp_AECD operation	Warning on High.Temp_AECD operation	<ul style="list-style-type: none"> High Temperature AECD_EGR valve limiting state warning
523604	2	CAN1 bus off	CAN1 bus off	<ul style="list-style-type: none"> Short circuit in CAN1 +B/GND or traffic abnormally high
523606	2	Pressure relief valve error	Pressure relief valve error	<ul style="list-style-type: none"> Pressure relief valve error
523607	3	PCV or PRV drive line short	PCV or PRV drive line short to +B at power supply side (COM3), or all driver line short to +B simultaneously	<ul style="list-style-type: none"> Wiring harness short to +B
	4		PCV or PRV drive line short to ground at power supply side (COM3), or all driver line short to ground simultaneously	<ul style="list-style-type: none"> Wiring harness short to ground
523608	2	High pressure delivery system too high	High pressure delivery system too high	<ul style="list-style-type: none"> +B short of relay driving circuit when relay is on
523609	6	Coil short in PCV	Coil short in PCV	<ul style="list-style-type: none"> PCV coil short (over current)
523610	6	Coil short in PRV	Coil short in PRV	<ul style="list-style-type: none"> PRV coil short (over current)
523611	2	High pressure pump too high	High pressure pump too high	<ul style="list-style-type: none"> High pressure pump too high
523612	5	Open circuit of harness or coil in PCV line	Open circuit of harness or coil in PCV line	<ul style="list-style-type: none"> Open circuit of harness Open circuit of PCV coil
523613	5	Open circuit of harness or coil in PRV line	Open circuit of harness or coil in PRV line	<ul style="list-style-type: none"> Open circuit of harness Open circuit of PRV coil
523614	2	Internal IC of ECU abnormality	Internal IC (VDIC2) clock error 1	<ul style="list-style-type: none"> Battery voltage is normal CPU is normal Starter Switch signal (ECU: V12 terminal) is not activated
			Internal IC (VDIC2) clock error 2	
			Internal IC (VDIC2) communication error 1	
			Internal IC (VDIC2) communication error 2	
523620	2	ECU-ACU CAN communication error	ECU-ACU CAN communication error	<ul style="list-style-type: none"> ECU-ACU CAN communication error (Line Open)
523621	3	Lamp driving circuit error	Stop Lamp error	<ul style="list-style-type: none"> +B short of lamp driving circuit when lamp is on
523622	3	Lamp driving circuit error	Low oil pressure Lamp error	<ul style="list-style-type: none"> +B short of lamp driving circuit when lamp is on
523623	3	Active regeneration Lamp error	Active regeneration Lamp error	<ul style="list-style-type: none"> +B short of lamp driving circuit when lamp is on
523624	3	Over heat Lamp error	Over heat Lamp error	<ul style="list-style-type: none"> +B short of lamp driving circuit when lamp is on
523625	2	TSC1 priority reception error	TSC1 priority reception error	<ul style="list-style-type: none"> Highest priority reception from other than ACU

J1939-73		Description	DTC Description	Diagnosis
SPN	FMI			
523626	2	SUB CPU software version unmatched	SUB CPU software version unmatched	• SUB CPU software version unmatched
523627	8	PCV driving circuit error	PCV driving circuit error	• Open circuit of discharge MOS-IC in ECU
523628	8	PRV driving circuit error	PRV driving circuit error	• Open circuit of discharge MOS-IC in ECU
523700	13	EEPROM checksum not coincident	KBT area EEPROM checksum not coincident	• KBT area EEPROM checksum not coincident

Fig.: 2-3-1

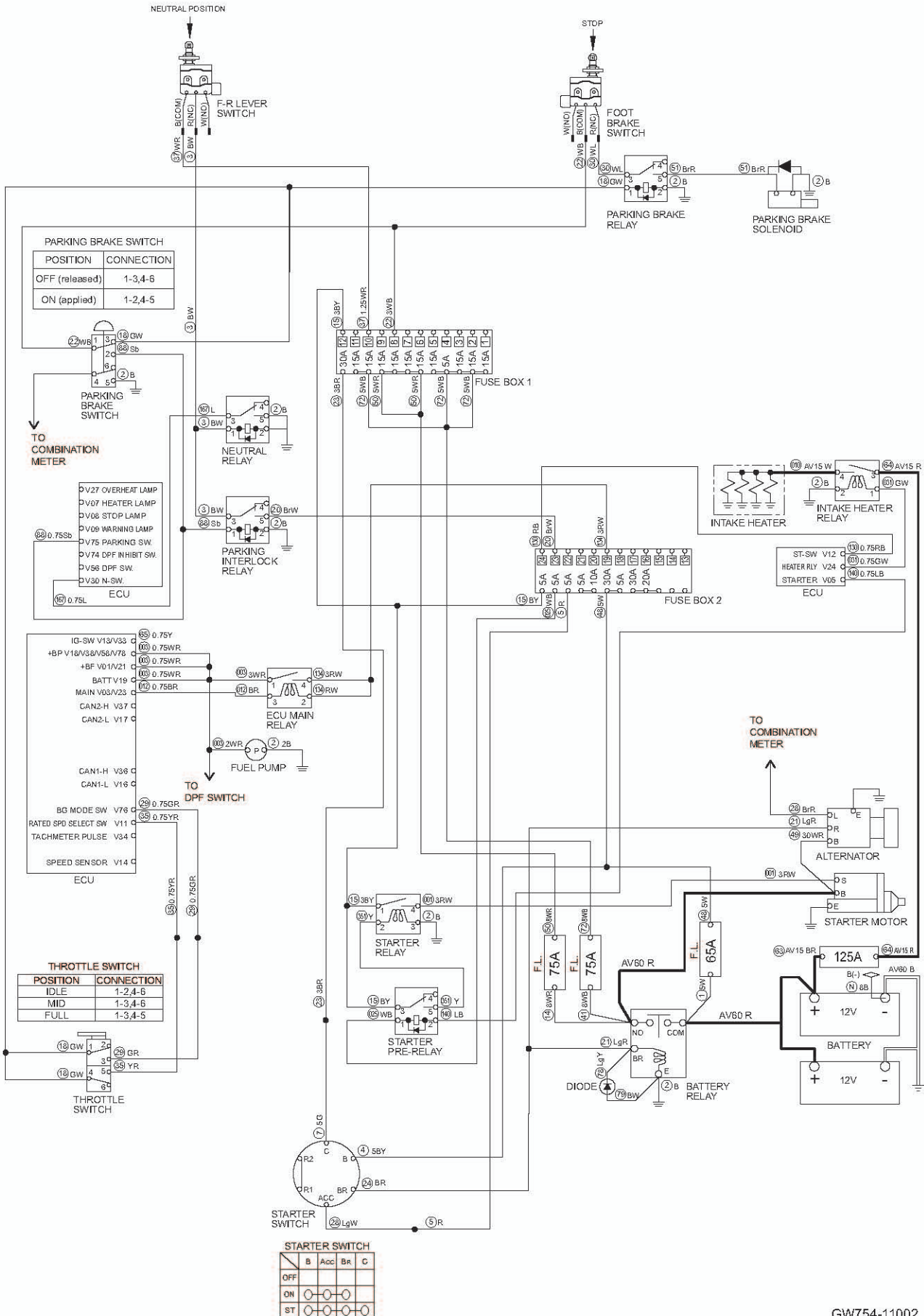

2-3. Engine

Check following items before troubleshooting.

- No blown fuses and power is applied up to fuses.
- Check any ground circuit which belongs to components to be checked.
- Engine warning lamp or engine stop lamp must not be lighting. If engine warning lamp or engine stop lamp lights, refer to troubleshooting of engine manufacturer.

2-3-1. Engine will not start (Starter motor does not run) 1/3

- F-R lever must be in "N".
- Parking brake switch must be applied.

Reference Fig.: 2-3-1

Check point	Check/Cause	Action
1. Battery	<ul style="list-style-type: none"> • Measure battery voltage or specific gravity. Standard voltage : 12 V or more Standard gravity : 1.26 or more • If value is below standard, battery capacity is insufficient. 	Charge or replace battery.
2. Starter Switch	<ul style="list-style-type: none"> • Check continuity between O-O according to starter switch connection table. Switch is OK if there is continuity between connection O-O. • If there is no continuity, starter switch is faulty. 	Replace starter switch.
3. Starter Motor	<p>(1) When starter switch is ON, measure voltage between starter motor terminal B and chassis ground. Standard voltage : 12 V or more</p> <p>(2) When starter switch is START, measure voltage between starter motor terminal S and chassis ground. Standard voltage : 12 V or more</p> <ul style="list-style-type: none"> • If above items (1) and (2) are OK and starter motor does not run, starter motor is faulty. 	Replace starter motor.
4. Starter Relay	<p>(1) When starter switch is START, measure voltage between starter relay terminal 2 inlet wire Y and chassis ground. Standard voltage : 12 V or more</p> <p>(2) When starter switch is START, measure voltage between starter relay terminal 1 inlet wire BY and chassis ground. Standard voltage : 12 V or more</p> <p>(3) When starter switch is START, measure voltage between starter relay terminal 4 outlet wire RW and chassis ground Standard voltage : 12 V or more</p> <ul style="list-style-type: none"> • If above items (1) and (2) are OK and item (3) is NG, starter relay is faulty. 	Replace starter relay.

Fig.: 2-3-1

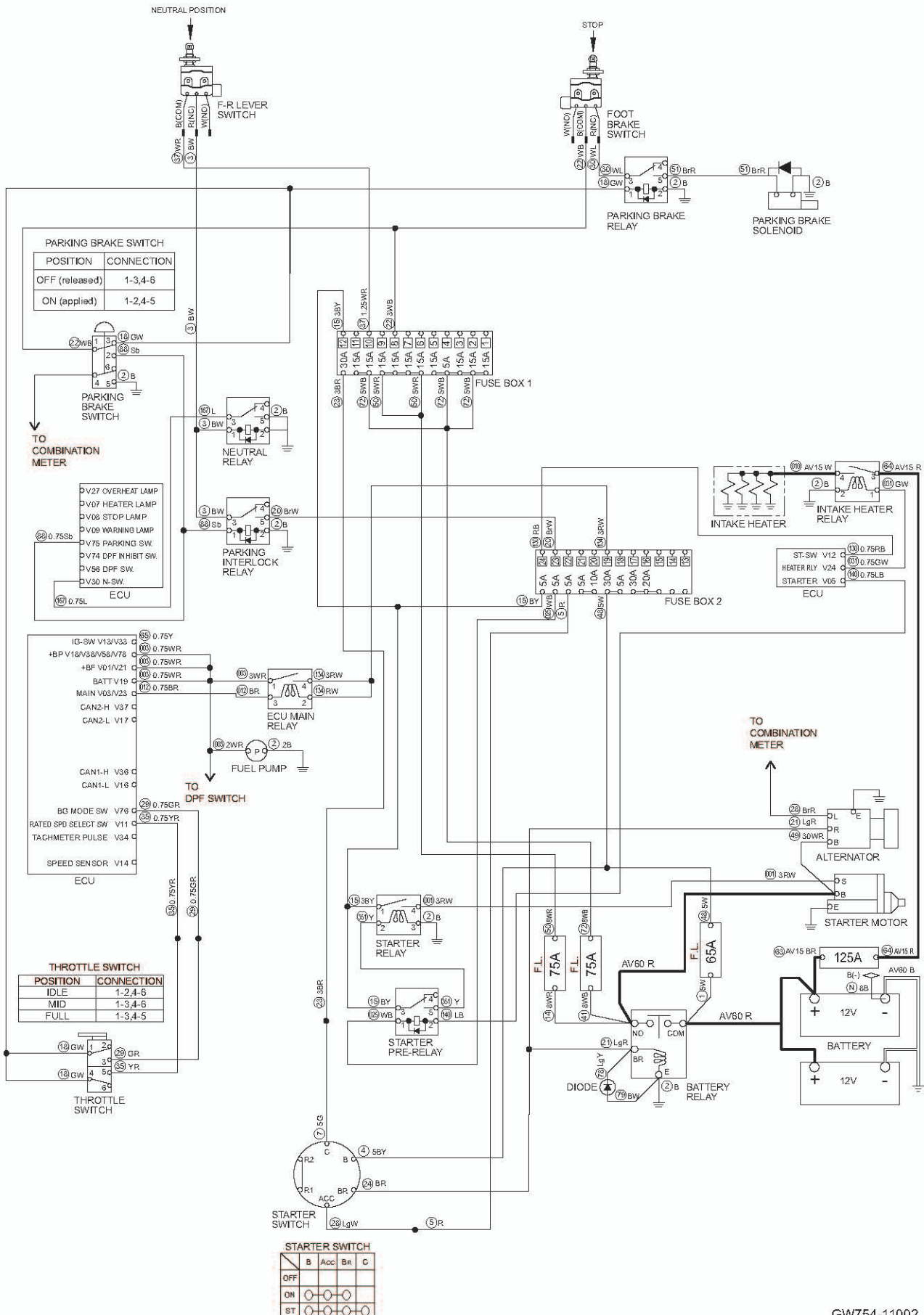

2-3-1. Engine will not start (Starter motor does not run) 2/3

- F-R lever must be in "N".
- Parking brake switch must be applied.

Reference Fig.: 2-3-1

Check point	Check/Cause	Action
5. Starter Pre-Relay	<p>(1) When starter switch is START, measure voltage between starter pre-relay terminal 1 inlet wire WB and chassis ground. Standard voltage : 12 V or more</p> <p>(2) When starter switch is START, measure voltage between starter pre-relay terminal 3 inlet wire BY and chassis ground. Standard voltage : 12 V or more</p> <p>(3) When starter switch is START, measure voltage between starter pre-relay terminal 5 outlet wire Y and chassis ground. Standard voltage : 12 V or more</p> <ul style="list-style-type: none"> • If above items (1) and (2) are OK and item (3) is NG, starter pre-relay is faulty. 	Replace starter pre-relay.
6. Battery Relay	<p>(1) When starter switch is OFF, measure voltage between battery relay primary terminal COM and chassis ground. Standard voltage : 12 V or more</p> <p>(2) When starter switch is ON, measure voltage between battery relay coil terminal BR inlet wire LgR and coil ground terminal E. Standard voltage : 12 V or more</p> <p>(3) When starter switch is ON, measure voltage between battery relay secondary terminal NO and chassis ground. Standard voltage : 12 V or more</p> <ul style="list-style-type: none"> • If above items (1) and (2) are OK and item (3) is NG, battery relay is faulty. 	Replace battery relay.
7. F-R Lever Switch	<p>(1) When starter switch is ON, measure voltage between F-R lever switch terminal COM inlet wire WR and chassis ground. Standard voltage : 12 V or more</p> <p>(2) When starter switch is ON, measure voltage between F-R lever switch terminal NC outlet wire BW and chassis ground. Standard voltage : 12 V or more</p> <ul style="list-style-type: none"> • If above item (1) is OK and item (2) is NG, F-R lever switch is faulty. 	Replace F-R lever switch.
8. Parking Interlock Relay	<p>(1) When starter switch is ON, measure voltage between parking interlock relay terminal 1 inlet wire Sb and chassis ground. Standard voltage : 12 V or more</p> <p>(2) When starter switch is ON, measure voltage between parking interlock relay terminal 3 inlet wire BW and chassis ground. Standard voltage : 12 V or more</p> <p>(3) When starter switch is ON, measure voltage between parking interlock relay terminal 5 outlet wire BrW and chassis ground. Standard voltage : 12 V or more</p> <ul style="list-style-type: none"> • If above items (1) and (2) are OK and item (3) is NG, parking interlock relay is faulty. 	Replace parking interlock relay.

Fig.: 2-3-1

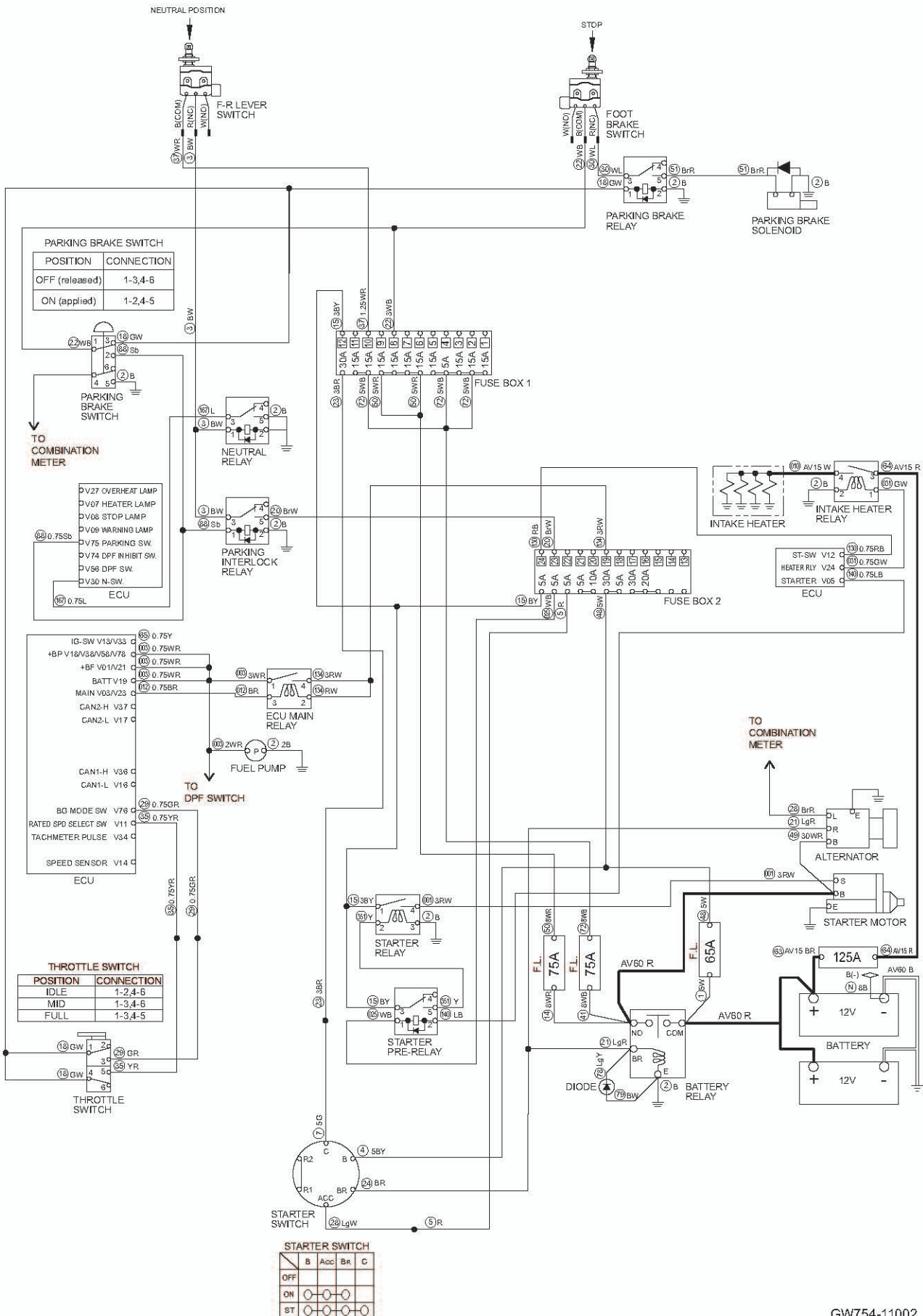

2-3-1. Engine will not start (Starter motor does not run) 3/3

- F-R lever must be in "N".
- Parking brake switch must be applied.

Reference Fig.: 2-3-1

Check point	Check/Cause	Action
9. Neutral Relay	<p>(1) When starter switch is ON, measure voltage between neutral relay terminal 1 inlet wire BW and chassis ground. Standard voltage : 12 V or more</p> <p>(2) When starter switch is ON, check continuity between neutral relay terminal 5 outlet wire B and chassis ground. There is continuity in normal condition.</p> <p>(3) When starter switch is ON, check continuity between neutral relay terminal 3 inlet wire L and chassis ground. There is continuity in normal condition.</p> <ul style="list-style-type: none"> • If above items (1) and (2) are OK and item (3) is NG, neutral relay is faulty. 	Replace neutral relay.
10. Parking Brake Switch	<p>(1) When starter switch is ON, measure voltage between parking brake switch terminal 1 inlet wire WB and chassis ground. Standard voltage : 12 V or more</p> <p>(2) When starter switch is ON, measure voltage between parking brake switch terminal 2 outlet wire Sb and chassis ground. Standard voltage : 12 V or more</p> <ul style="list-style-type: none"> • If above item (1) is OK and item (2) is NG, parking brake switch is faulty. 	Replace parking brake switch.
11. Harness Connecting Between Terminals	<ul style="list-style-type: none"> • Measure resistance of harness connecting between terminals. Standard resistance : 10 Ω or less • If resistance is abnormal, harness is faulty. 	Repair or replace harness.

Fig.: 2-3-1

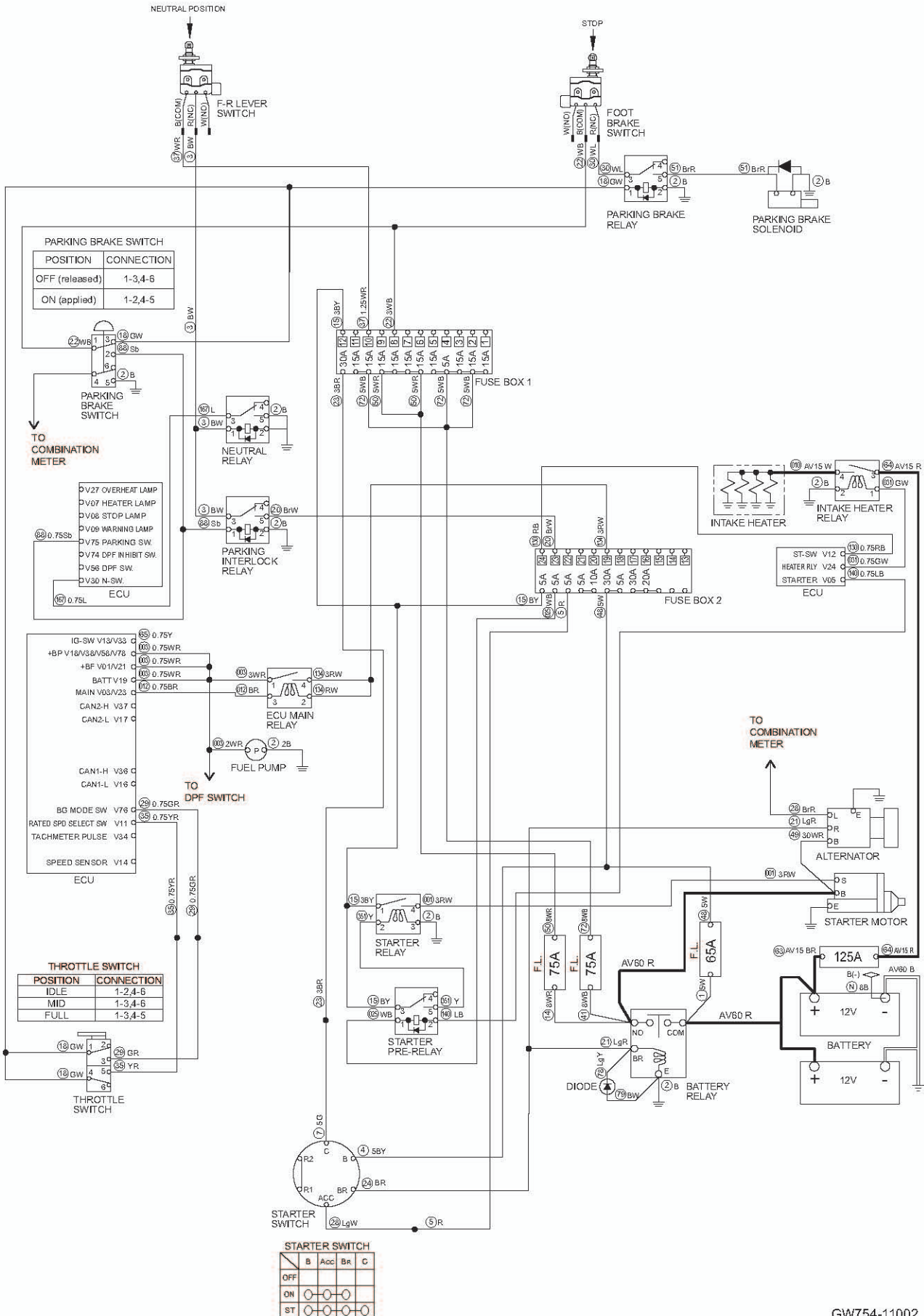

2-3-2. Engine will not start (But starter motor runs)

- In case of engine will not start while starter motor runs, generally trouble is caused by that fuel is not supplied, supply amount of fuel is extremely low, or selection of fuel is not appropriate.
- Check that fuel is supplied to inlet of fuel pump.

Reference Fig.: 2-3-1

Check point	Check/Cause	Action
1. Fuel Pump	<ul style="list-style-type: none"> • When starter switch is ON, measure voltage between fuel pump terminal inlet wire WR and chassis ground. Standard voltage : 12 V or more • If above item is OK and fuel pump does not operate, fuel pump is faulty. 	Repair or replace fuel pump.
2. ECU Main Relay	<p>(1) Measure voltage between ECU main relay terminal 2 and 4 inlet wire RW and chassis ground. Standard voltage : 12 V or more</p> <p>(2) When starter switch is ON, measure voltage between ECU main relay terminal 1 outlet wire WR and chassis ground. Standard voltage : 12 V or more</p> <ul style="list-style-type: none"> • If above item (1) is OK and item (2) is NG, ECU main relay is faulty. 	Replace ECU main relay.
3. Harness Connecting Between Terminals	<ul style="list-style-type: none"> • Measure resistance of harness connecting between terminals. Standard resistance : 10 Ω or less • If resistance is abnormal, harness is faulty. 	Repair or replace harness.

2-3-3. No charging

Reference Fig.: 2-3-1

Check point	Check/Cause	Action
1. Alternator	<ul style="list-style-type: none"> • After starting engine, measure voltage between alternator terminal B wire WR and chassis ground. Standard voltage : At least intermediate engine speed, 14 V or more • If voltage is lower than standard, alternator is faulty. • If voltage is normal and battery is not charged, battery is faulty. 	Replace alternator or battery.

Fig.: 2-3-1

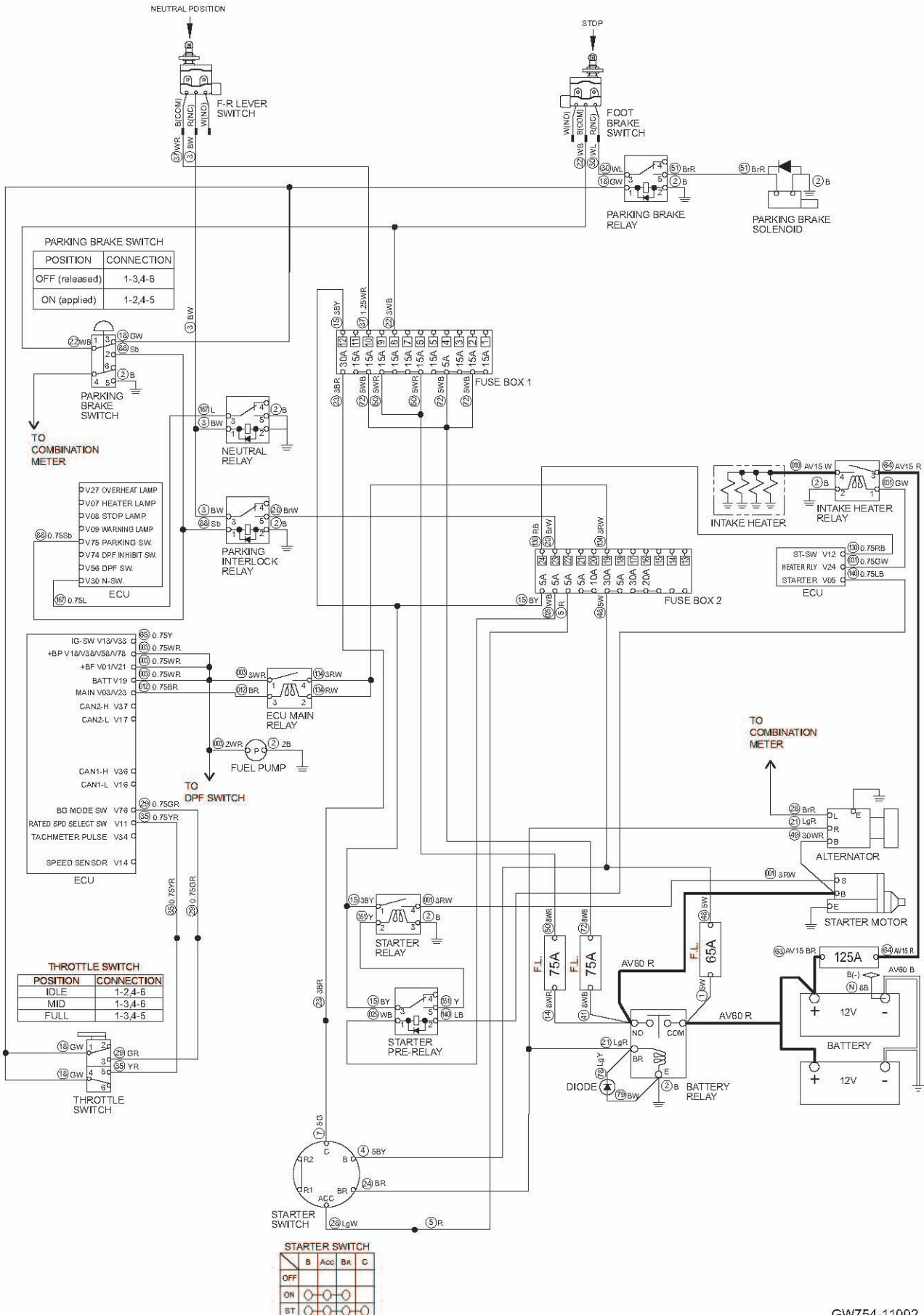

2-3-4. Intake heater is not heated (Engine starting performance is bad in cold weather)

Reference Fig. : 2-3-1

Check point	Check/Cause	Action
1. Intake Heater	<ul style="list-style-type: none"> When starter switch is ON, measure voltage between intake heater terminal inlet wire W and chassis ground. Standard voltage : 12 V or more If voltage is OK and fuel pump does not operate, intake heater is faulty. 	Replace intake heater.
2. Intake Heater Relay	<p>(1) When starter switch is ON, measure voltage between intake heater relay terminal 1 inlet wire GW and chassis ground. Standard voltage : 12 V or more</p> <p>(2) Measure voltage between intake heater relay terminal 3 inlet wire R and chassis ground. Standard voltage : 12 V or more</p> <p>(3) When starter switch is ON, measure voltage between intake heater relay terminal 4 outlet wire W and chassis ground. Standard voltage : 12 V or more</p> <ul style="list-style-type: none"> If above items (1) and (2) are OK and item (3) is NG, intake heater relay is faulty. 	Replace intake heater relay.
3. Harness Connecting Between Terminals	<ul style="list-style-type: none"> Measure resistance of harness connecting between terminals. Standard resistance : 10 Ω or less If resistance is abnormal, harness is faulty. 	Repair or replace harness.

2-3-5. Starter motor runs even when F-R lever is not at "N"

Reference Fig. : 2-3-1

Check point	Check/Cause	Action
1. F-R Lever Switch	<ul style="list-style-type: none"> When starter switch is OFF and F-R lever is "F" or "R", check continuity between F-R lever switch terminal COM wire WR and terminal NC wire BW. There is no continuity in normal condition. If there is continuity, F-R lever switch is faulty. 	Replace F-R lever switch.

2-3-6. Engine speed cannot be switched

Reference Fig. : 2-3-1

Check point	Check/Cause	Action
1. Throttle Switch	<p>(1) When throttle switch is "IDLE", check continuity between throttle switch terminals 1 and 2, 4 and 6. There is continuity in normal condition.</p> <p>(2) When throttle switch is "MID", check continuity between throttle switch terminals 1 and 3, 4 and 6. There is continuity in normal condition.</p> <p>(3) When throttle switch is "FULL", check continuity between throttle switch terminals 1 and 3, 4 and 5. There is continuity in normal condition.</p> <ul style="list-style-type: none"> If above item (1), (2) or (3) is NG, throttle switch is faulty. 	Replace throttle switch.
2. Harness Connecting Between Terminals	<ul style="list-style-type: none"> Measure resistance of harness connecting between terminals. Standard resistance : 10 Ω or less If resistance is abnormal, harness is faulty. 	Repair or replace harness.

Fig.: 2-3-1

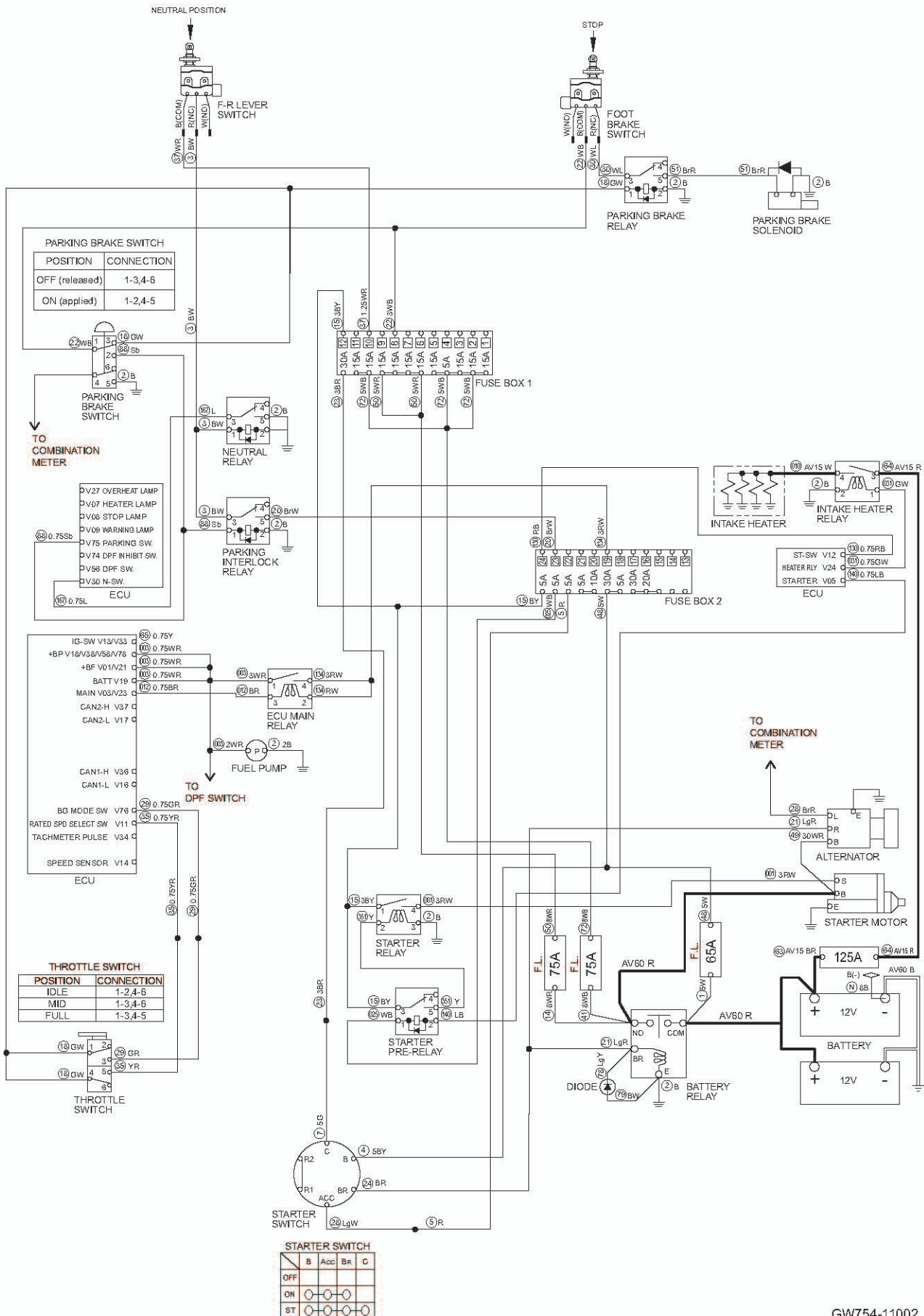

2-4. Propulsion System

Check following items before troubleshooting.

- No blown fuses and power is applied up to fuses.
- When measuring voltage and current without disconnecting connectors, refer to "Measuring voltage and current flowing using tester" (P.11-006 to P.11-008).
- Check any ground circuit which belongs to components to be checked.

2-4-1. Machine moves neither forward nor backward

- Parking brake switch must be released.
- Foot brake switch must be OFF (Brake pedal is not depressed).

Reference Fig.: 2-3-1

Check point	Check/Cause	Action
1. Battery	<ul style="list-style-type: none"> • Measure battery voltage or specific gravity. Standard voltage : 12 V or more Standard gravity : 1.26 or more • If value is below standard, battery capacity is insufficient. 	Charge or replace battery.
2. Parking Brake Solenoid	<ul style="list-style-type: none"> • Disconnect harness and measure resistance of coil. Standard resistance : 12.3 Ω • If measured resistance is abnormal, parking brake solenoid is faulty. 	Replace parking brake solenoid.
3. Parking Brake Relay	<p>(1) When starter switch is ON, measure voltage between parking brake relay terminal 1 inlet wire GW and chassis ground. Standard voltage : 12 V or more</p> <p>(2) When starter switch is ON, measure voltage between parking brake relay terminal 3 inlet wire WL and chassis ground. Standard voltage : 12 V or more</p> <p>(3) When starter switch is ON, measure voltage between parking brake relay terminal 5 outlet wire BrR and chassis ground. Standard voltage : 12 V or more</p> <ul style="list-style-type: none"> • If above items (1) and (2) are OK and item (3) is NG, parking brake relay is faulty. 	Replace parking brake relay.
4. Foot Brake Switch	<ul style="list-style-type: none"> • Check continuity between foot brake switch terminal COM wire WB and terminal NC wire WL. There is continuity in normal condition. • If there is no continuity, foot brake switch is faulty. 	Replace foot brake switch.
5. Parking Brake Switch	<p>(1) When starter switch is ON, measure voltage between parking brake switch terminal 1 inlet wire WB and chassis ground. Standard voltage : 12 V or more</p> <p>(2) When starter switch is ON, measure voltage between parking brake switch terminal 3 outlet wire GW and chassis ground. Standard voltage : 12 V or more</p> <ul style="list-style-type: none"> • If above item (1) is OK and item (2) is NG, parking brake switch is faulty. 	Replace parking brake switch.
6. Harness Connecting Between Terminals	<ul style="list-style-type: none"> • Measure resistance of harness connecting between terminals. Standard resistance : 10 Ω or less • If resistance is abnormal, harness is faulty. 	Repair or replace harness.

Fig.: 2-3-1

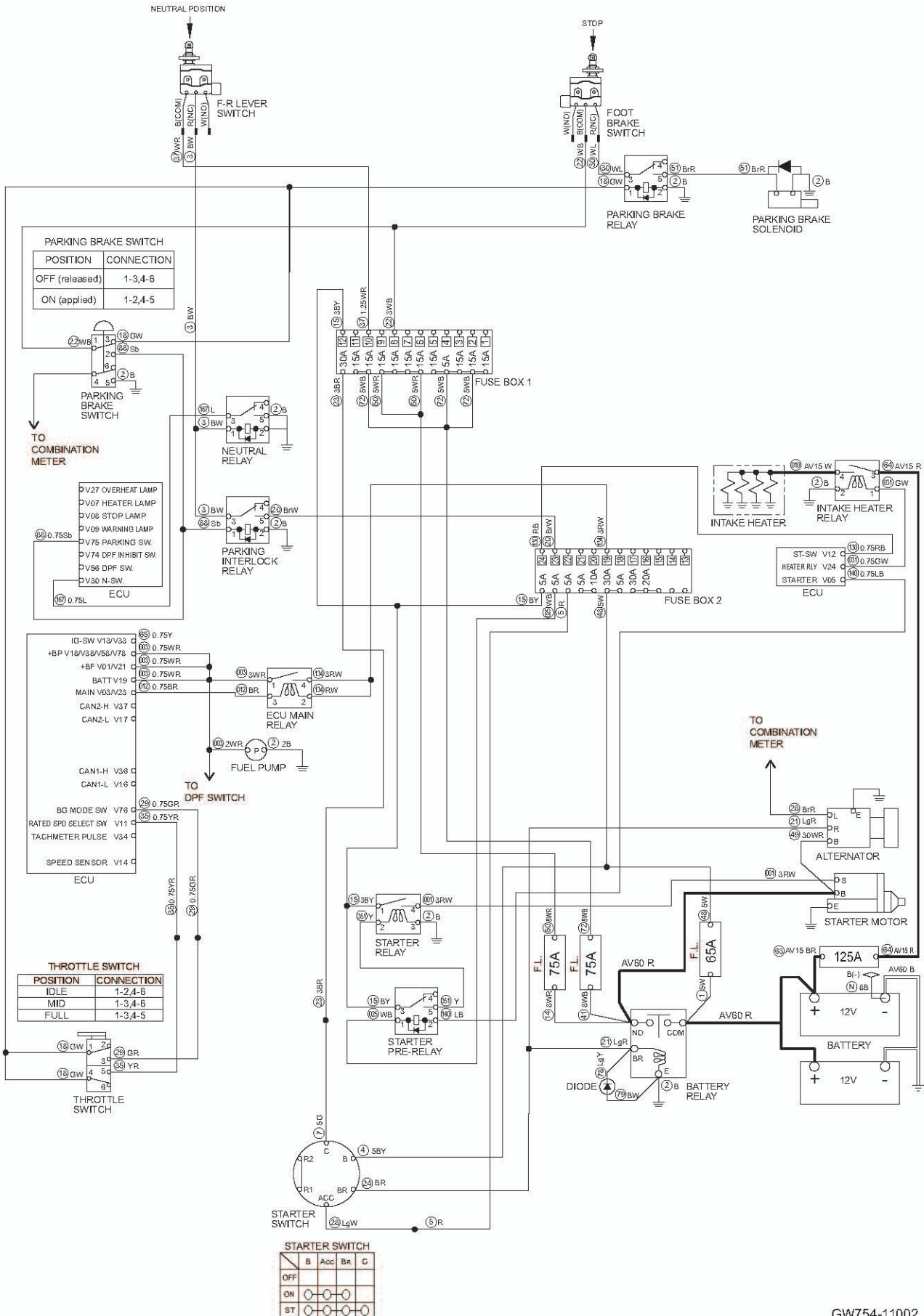

2-4-2. Brake cannot be released

- Parking brake switch must be released.
- Foot brake switch must be OFF (Brake pedal is not depressed).

Reference Fig.: 2-3-1

Check point	Check/Cause	Action
1. Parking Brake Solenoid	<ul style="list-style-type: none"> • Disconnect harness and measure resistance of coil. Standard resistance : 12.3 Ω • If measured resistance is abnormal, parking brake solenoid is faulty. 	Replace parking brake solenoid.
2. Parking Brake Switch	<p>(1) When starter switch is ON, measure voltage between parking brake switch terminal 1 inlet wire WB and chassis ground. Standard voltage : 12 V or more</p> <p>(2) When starter switch is ON, measure voltage between parking brake switch terminal 3 outlet wire GW and chassis ground. Standard voltage : 12 V or more</p> <ul style="list-style-type: none"> • If above item (1) is OK and item (2) is NG, parking brake switch is faulty. 	Replace parking brake switch.
3. Foot Brake Switch	<ul style="list-style-type: none"> • Check continuity between foot brake switch terminal COM wire WB and terminal NC wire WL. There is continuity in normal condition. • If there is no continuity, foot brake switch is faulty. 	Replace foot brake switch.
4. Parking Brake Relay	<p>(1) When starter switch is ON, measure voltage between parking brake relay terminal 1 inlet wire GW and chassis ground. Standard voltage : 12 V or more</p> <p>(2) When starter switch is ON, measure voltage between parking brake relay terminal 3 inlet wire WL and chassis ground. Standard voltage : 12 V or more</p> <p>(3) When starter switch is ON, measure voltage between parking brake relay terminal 5 outlet wire BrR and chassis ground. Standard voltage : 12 V or more</p> <ul style="list-style-type: none"> • If above items (1) and (2) are OK and item (3) is NG, parking brake relay is faulty. 	Replace parking brake relay.
5. Harness Connecting Between Terminals	<ul style="list-style-type: none"> • Measure resistance of harness connecting between terminals. Standard resistance : 10 Ω or less • If resistance is abnormal, harness is faulty. 	Repair or replace harness.

Fig.: 2-3-1

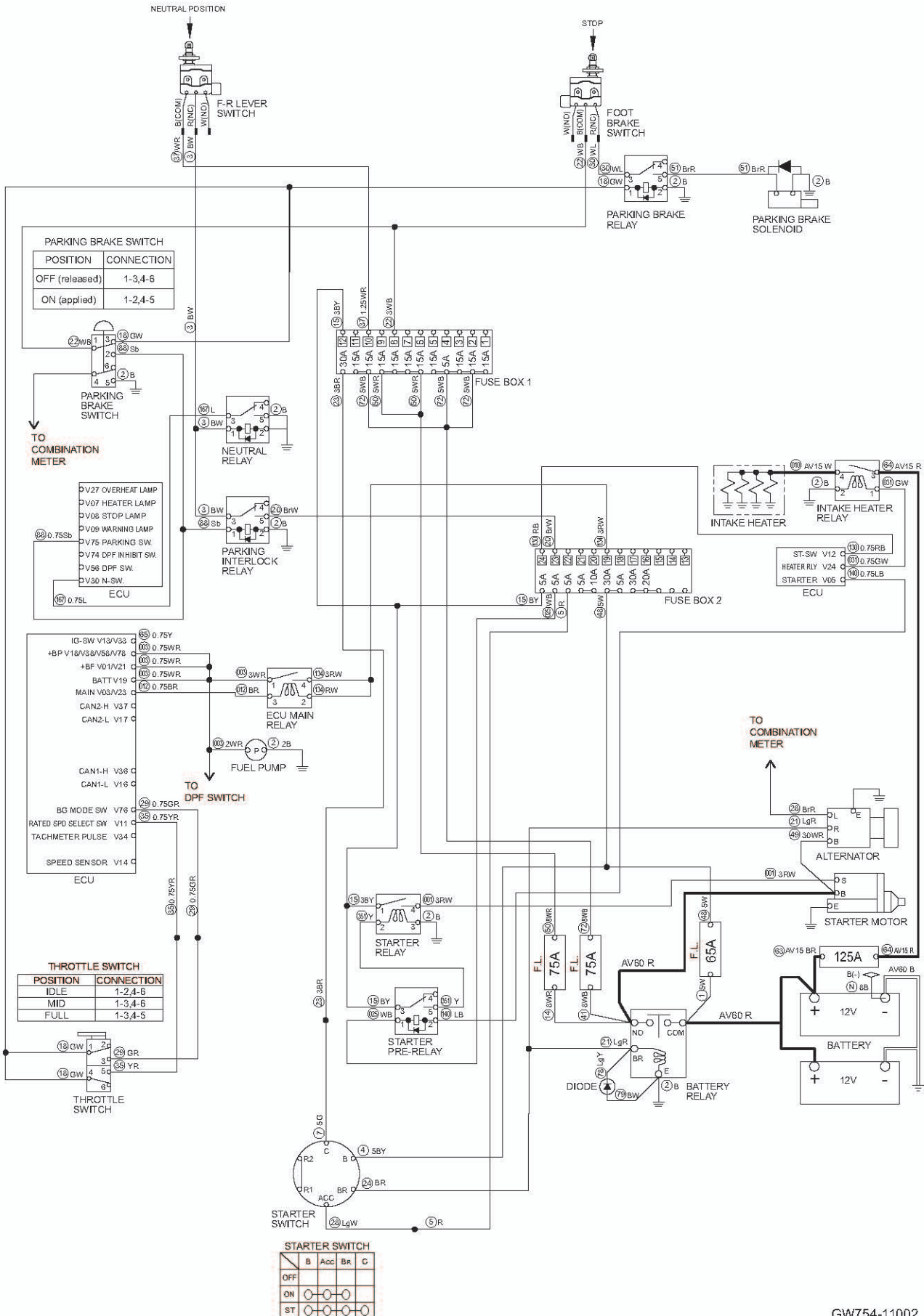

2-4-3. Brake does not work

- Parking brake switch must be applied.
- Foot brake switch must be OFF (Brake pedal is not depressed).

Reference Fig.: 2-3-1

Check point	Check/Cause	Action
1. Parking Brake Solenoid	<ul style="list-style-type: none"> • Disconnect harness and measure resistance of coil. Standard resistance : 12.3 Ω • If measured resistance is abnormal, parking brake solenoid is faulty. 	Replace parking brake solenoid.
2. Parking Brake Switch	<ul style="list-style-type: none"> • When starter switch is ON, measure voltage between parking brake switch terminal 3 outlet wire GW and chassis ground. There is no electricity in normal condition. • If there is electricity, parking brake switch is faulty. 	Replace parking brake switch.
3. Foot Brake Switch	<ul style="list-style-type: none"> • Check continuity between foot brake switch terminal COM wire WB and terminal NC wire WL. There is continuity in normal condition. • If there is no continuity, foot brake switch is faulty. 	Replace foot brake switch.
4. Parking Brake Relay	<p>(1) When starter switch is ON, measure voltage between parking brake relay terminal 1 inlet wire GW and chassis ground. There is no electricity in normal condition.</p> <p>(2) When starter switch is ON, measure voltage between parking brake relay terminal 3 inlet wire WL and chassis ground. Standard voltage : 12 V or more</p> <p>(3) When starter switch is ON, measure voltage between parking brake relay terminal 5 outlet wire BrR and chassis ground. There is no electricity in normal condition.</p> <ul style="list-style-type: none"> • If above items (1) and (2) are OK and item (3) is NG, parking brake relay is faulty. 	Replace parking brake relay.
5. Harness Connecting Between Terminals	<ul style="list-style-type: none"> • Measure resistance of harness connecting between terminals. Standard resistance : 10 Ω or less • If resistance is abnormal, harness is faulty. 	Repair or replace harness.

Fig.: 2-5-1

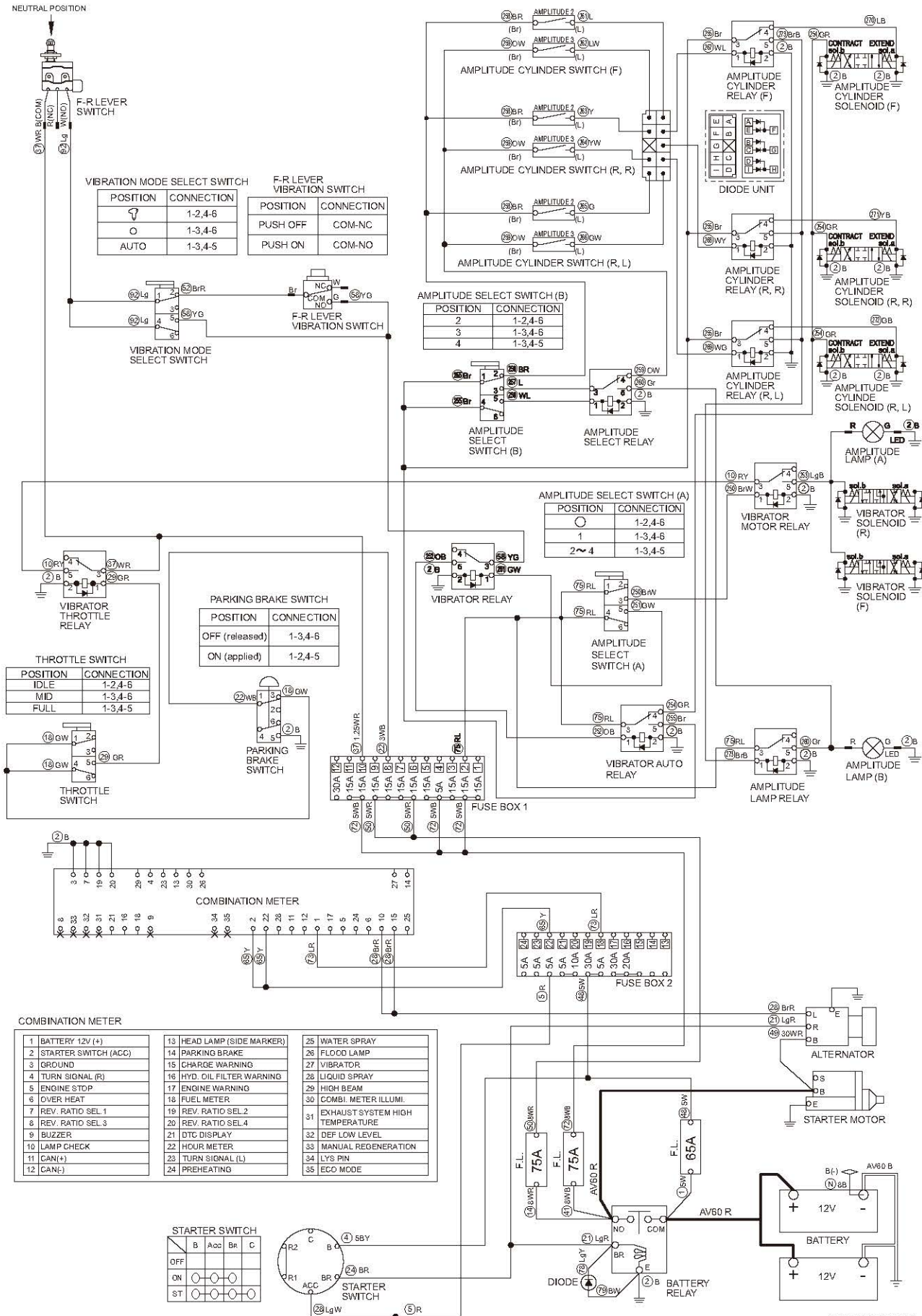

COMBINATION METER

1 BATTERY 12V (+)	13 HEAD LAMP (SIDE MARKER)	25 WATER SPRAY
2 STARTER SWITCH (ACC)	14 PARKING BRAKE	26 FLOOD LAMP
3 GROUND	15 CHARGE WARNING	27 VIBRATOR
4 TURN SIGNAL (R)	16 HYD. OIL FILTER WARNING	28 LIQUID SPRAY
5 ENGINE STOP	17 ENGINE WARNING	29 HIGH BEAM
6 OVER HEAT	18 FUEL METER	30 COMBI. METER ILLUMI.
7 REV. RATIO SEL 1	19 REV. RATIO SEL 2	31 EXHAUST SYSTEM HIGH TEMPERATURE
8 REV. RATIO SEL 3	20 REV. RATIO SEL 4	32 DEF LOW LEVEL
9 BUZZER	21 DTC DISPLAY	33 MANUAL REGENERATION
10 LAMP CHECK	22 HOUR METER	34 LYS PIN
11 CAN(+)	23 TURN SIGNAL (L)	35 ECO MODE
12 CAN(-)	24 PREHEATING	

STARTER SWITCH

OFF	B	Acc	Br	C
ON	○	○	○	○
ST	○	○	○	○

2-5. Vibration

Check following items before troubleshooting.

- No blown fuses and power is applied up to fuses.
- Check any ground circuit which belongs to components to be checked.

2-5-1. No vibration occurs 1/2

- Parking brake switch must be released.
- Throttle switch must be "FULL".
- Amplitude select switch (A) must not be "O".

Reference Fig.: 2-5-1

Check point	Check/Cause	Action
1. Battery	<ul style="list-style-type: none"> • Measure battery voltage or specific gravity. Standard voltage : 12 V or more Standard gravity : 1.26 or more • If value is below standard, battery capacity is insufficient. 	Charge or replace battery.
2. Vibrator Solenoid (F)/(R)	<ul style="list-style-type: none"> • Disconnect harness and measure resistance of coil. Standard resistance : $10.3 \pm 0.52 \Omega$ • If measured resistance is abnormal, vibrator solenoid is faulty. 	Replace vibrator solenoid.
3. Vibrator Throttle Relay	<p>(1) When starter switch is ON, measure voltage between vibrator throttle relay terminal 1 inlet wire GR and chassis ground. Standard voltage : 12 V or more</p> <p>(2) When starter switch is ON, measure voltage between vibrator throttle relay terminal 3 inlet wire WR and chassis ground. Standard voltage : 12 V or more</p> <p>(3) When starter switch is ON, measure voltage between vibrator throttle relay terminal 5 outlet wire RY and chassis ground. Standard voltage : 12 V or more</p> <ul style="list-style-type: none"> • If above items (1) and (2) are OK and item (3) is NG, vibrator throttle relay is faulty. 	Replace vibrator throttle relay.
4. Vibrator Motor Relay	<p>(1) When starter switch is ON, measure voltage between vibrator motor relay terminal 1 inlet wire BrW and chassis ground. Standard voltage : 12 V or more</p> <p>(2) When starter switch is ON, measure voltage between vibrator motor relay terminal 3 inlet wire RY and chassis ground. Standard voltage : 12 V or more</p> <p>(3) When starter switch is ON, measure voltage between vibrator motor relay terminal 5 outlet wire LgB and chassis ground. Standard voltage : 12 V or more</p> <ul style="list-style-type: none"> • If above items (1) and (2) are OK and item (3) is NG, vibrator motor relay is faulty. 	Replace vibrator motor relay.

Fig.: 2-5-1

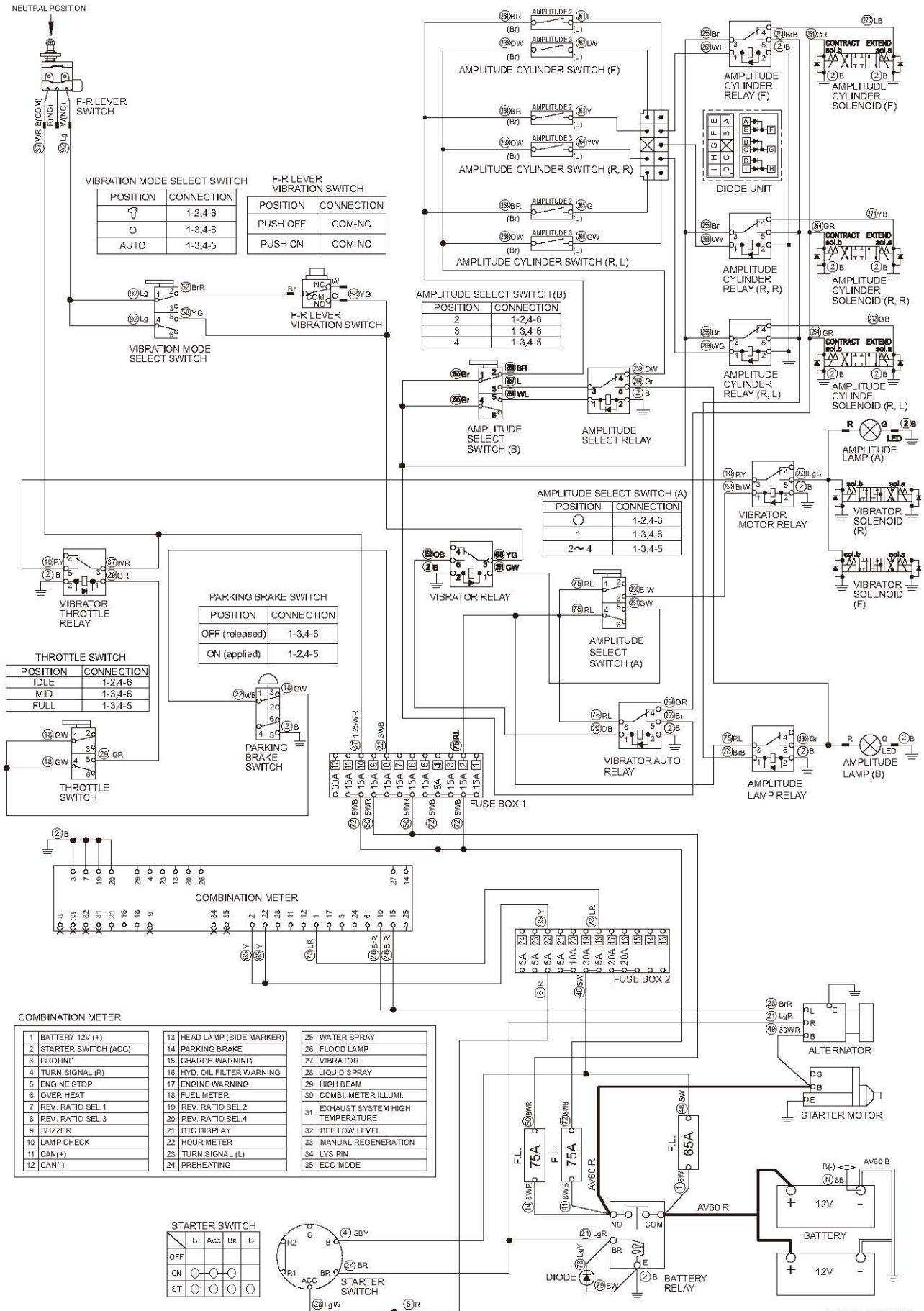

2-5-1. No vibration occurs 2/2

- Parking brake switch must be released.
- Throttle switch must be "FULL".
- Amplitude select switch (A) must not be "O".

Reference Fig.: 2-5-1

Check point	Check/Cause	Action
5. Amplitude Select Switch (A)	(1) When starter switch is ON, measure voltage between amplitude select switch (A) terminal 1 inlet wire RL and chassis ground. Standard voltage : 12 V or more (2) When starter switch is ON, measure voltage between amplitude select switch (A) terminal 3 outlet wire BrW and chassis ground. Standard voltage : 12 V or more • If above item (1) is OK and item (2) is NG, amplitude select switch (A) is faulty.	Replace amplitude select switch (A).
6. Harness Connecting Between Terminals	• Measure resistance of harness connecting between terminals. Standard resistance : 10 Ω or less • If resistance is abnormal, harness is faulty.	Repair or replace harness.

Fig.: 2-5-1

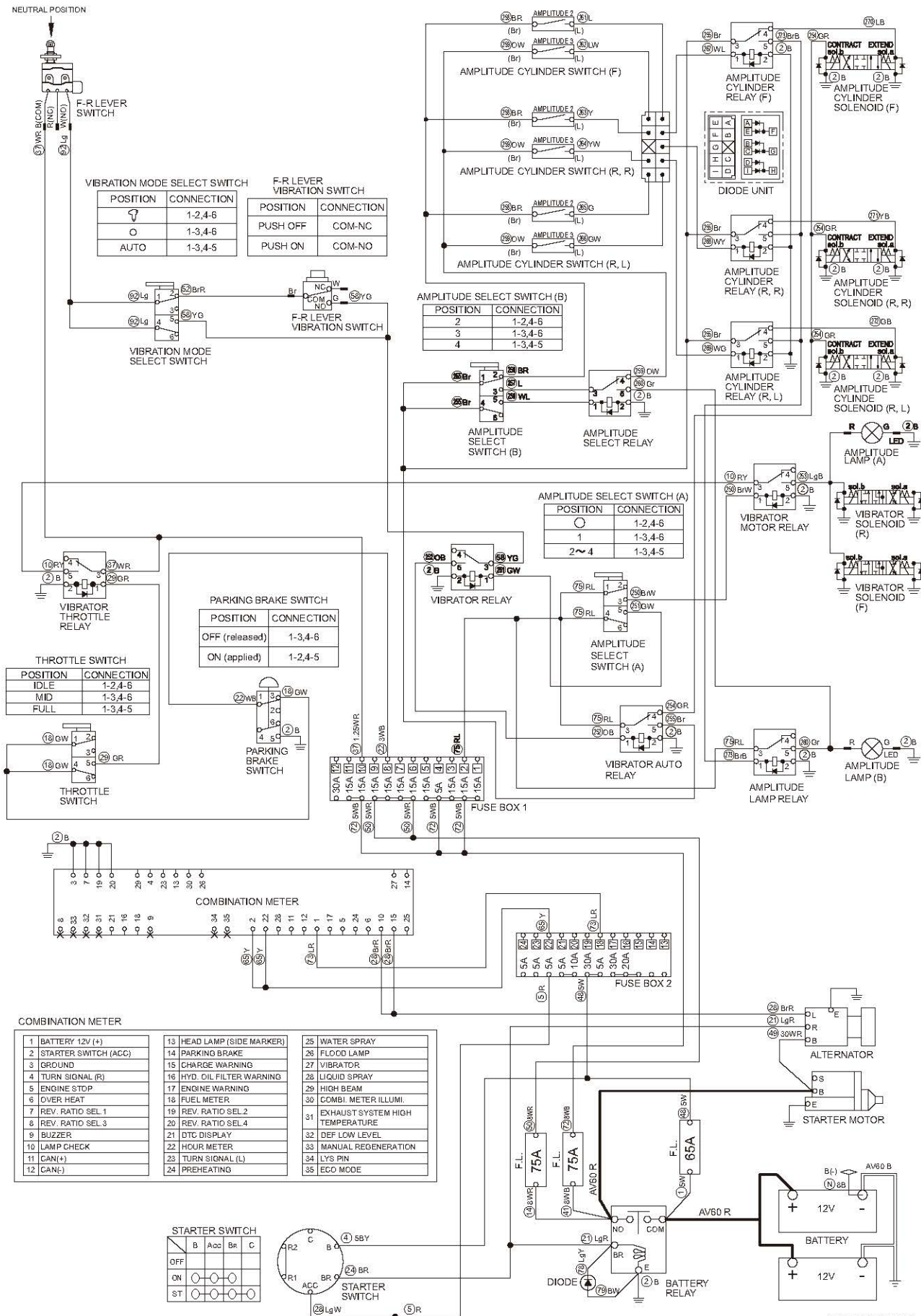

2-5-2. Vibration amplitude does not change (It vibrates at Amplitude 1, but vibration amplitude does not switch over at Amplitude 2 to 4 positions) 1/2

- Amplitude select switch (A) must be "2 ~ 4".
- F-R lever must be "F" or "R".
- Vibration mode select switch must be "AUTO".

Reference Fig.: 2-5-1

Check point	Check/Cause	Action
1. Amplitude Cylinder Solenoid	<ul style="list-style-type: none"> • Disconnect harness and measure resistance of coil. Standard resistance : 5.0 Ω • If measured resistance is abnormal, amplitude cylinder solenoid is faulty. 	Replace amplitude cylinder solenoid.
2. Vibrator AUTO Relay	<p>(1) When starter switch is ON, measure voltage between vibrator AUTO relay terminal 1 inlet wire OB and chassis ground. Standard voltage : 12 V or more</p> <p>(2) When starter switch is ON, measure voltage between vibrator AUTO relay terminal 3 inlet wire RL and chassis ground. Standard voltage : 12 V or more</p> <p>(3) When starter switch is ON, measure voltage between vibrator AUTO relay terminal 5 outlet wire Br and chassis ground. Standard voltage : 12 V or more</p> <ul style="list-style-type: none"> • If above items (1) and (2) are OK and item (3) is NG, vibrator AUTO relay is faulty. 	Replace vibrator AUTO relay.
3. Amplitude Cylinder Relay (F), (R,L), (R,R)	<p>(1) When starter switch is ON, measure voltage between amplitude cylinder relay terminals 1 inlet wire WL, wire WY, wire WG and chassis ground. There is no electricity in normal condition.</p> <p>(2) When starter switch is ON, measure voltage between amplitude cylinder relay terminals 3 inlet wire Br and chassis ground. Standard voltage : 12 V or more</p> <p>(3) When starter switch is ON, measure voltage between amplitude cylinder relay terminals.</p> <ul style="list-style-type: none"> • (F) : 4 outlet wire LB and chassis ground. • (R, L) : 4 outlet wire GB and chassis ground. • (R, R) : 4 outlet wire YB and chassis ground. <p>There is electricity in normal condition.</p> <ul style="list-style-type: none"> • If above items (1) and (2) are OK and either of item (3) is NG, defective amplitude cylinder relay is faulty. 	Replace faulty amplitude cylinder relay.

Fig.: 2-5-1

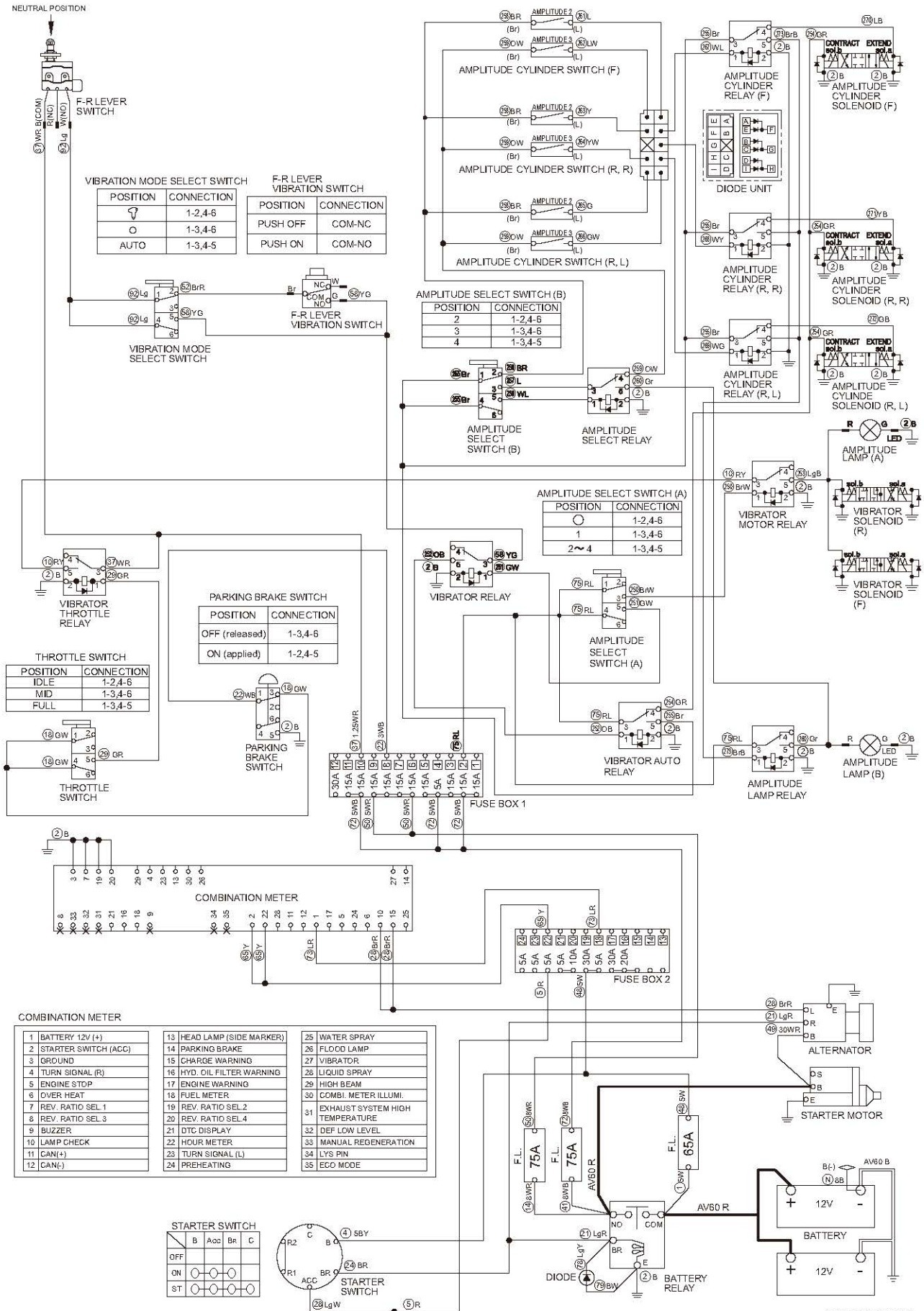

COMBINATION METER

1 BATTERY 12V (+)	13 HEAD LAMP (SIDE MARKER)	25 WATER SPRAY
2 STARTER SWITCH (ACC)	14 PARKING BRAKE	26 FLOOD LAMP
3 GROUND	15 CHARGE WARNING	27 VIBRATOR
4 TURN SIGNAL (R)	16 HYD. OIL FILTER WARNING	28 LIQUID SPRAY
5 ENGINE STOP	17 ENGINE WARNING	29 HIGH BEAM
6 OVER HEAT	18 FUEL METER	30 COMBI. METER ILLUMI.
7 REV. RATIO SEL 1	19 REV. RATIO SEL 2	31 EXHAUST SYSTEM HIGH TEMPERATURE
8 REV. RATIO SEL 3	20 REV. RATIO SEL 4	32 DEF LOW LEVEL
9 BUZZER	21 DTC DISPLAY	33 MANUAL REGENERATION
10 LAMP CHECK	22 HOUR METER	34 LYS PIN
11 TAN (+)	23 TURN SIGNAL (L)	35 ECO MODE
12 CAN (-)	24 PREHEATING	

STARTER SWITCH

OFF	B	Acc	Br	C
ON	○	○	○	○
ST	○	○	○	○

2-5-2. Vibration amplitude does not change (It vibrates at Amplitude 1, but vibration amplitude does not switch over at Amplitude 2 to 4 positions) 2/2

- Amplitude select switch (A) must be "2 ~ 4".
- F-R lever must be "F" or "R".
- Vibration mode select switch must be "AUTO".

Reference Fig.: 2-5-1

Check point	Check/Cause	Action
4. Vibrator Relay	<p>(1) When starter switch is ON, measure voltage between vibrator relay terminal 1 inlet wire GW and chassis ground. Standard voltage : 12 V or more</p> <p>(2) When starter switch is ON, measure voltage between vibrator relay terminal 3 inlet wire YG and chassis ground. Standard voltage : 12 V or more</p> <p>(3) When starter switch is ON, measure voltage between vibrator relay terminal 5 outlet wire OB and chassis ground. Standard voltage : 12 V or more</p> <ul style="list-style-type: none"> • If above items (1) and (2) are OK and item (3) is NG, vibrator relay is faulty. 	Replace vibrator relay.
5. Amplitude Select Switch (A)	<p>(1) When starter switch is ON, measure voltage between amplitude select switch (A) terminal 4 inlet wire RL and chassis ground. Standard voltage : 12 V or more</p> <p>(2) When starter switch is ON, measure voltage between amplitude select switch (A) terminal 5 outlet wire GW and chassis ground. Standard voltage : 12 V or more</p> <ul style="list-style-type: none"> • If above item (1) is OK and item (2) is NG, amplitude select switch (A) is faulty. 	Replace amplitude select switch (A).
6. Harness Connecting Between Terminals	<ul style="list-style-type: none"> • Measure resistance of harness connecting between terminals. Standard resistance : 10 Ω or less • If resistance is abnormal, harness is faulty. 	Repair or replace harness.

Fig.: 2-5-1

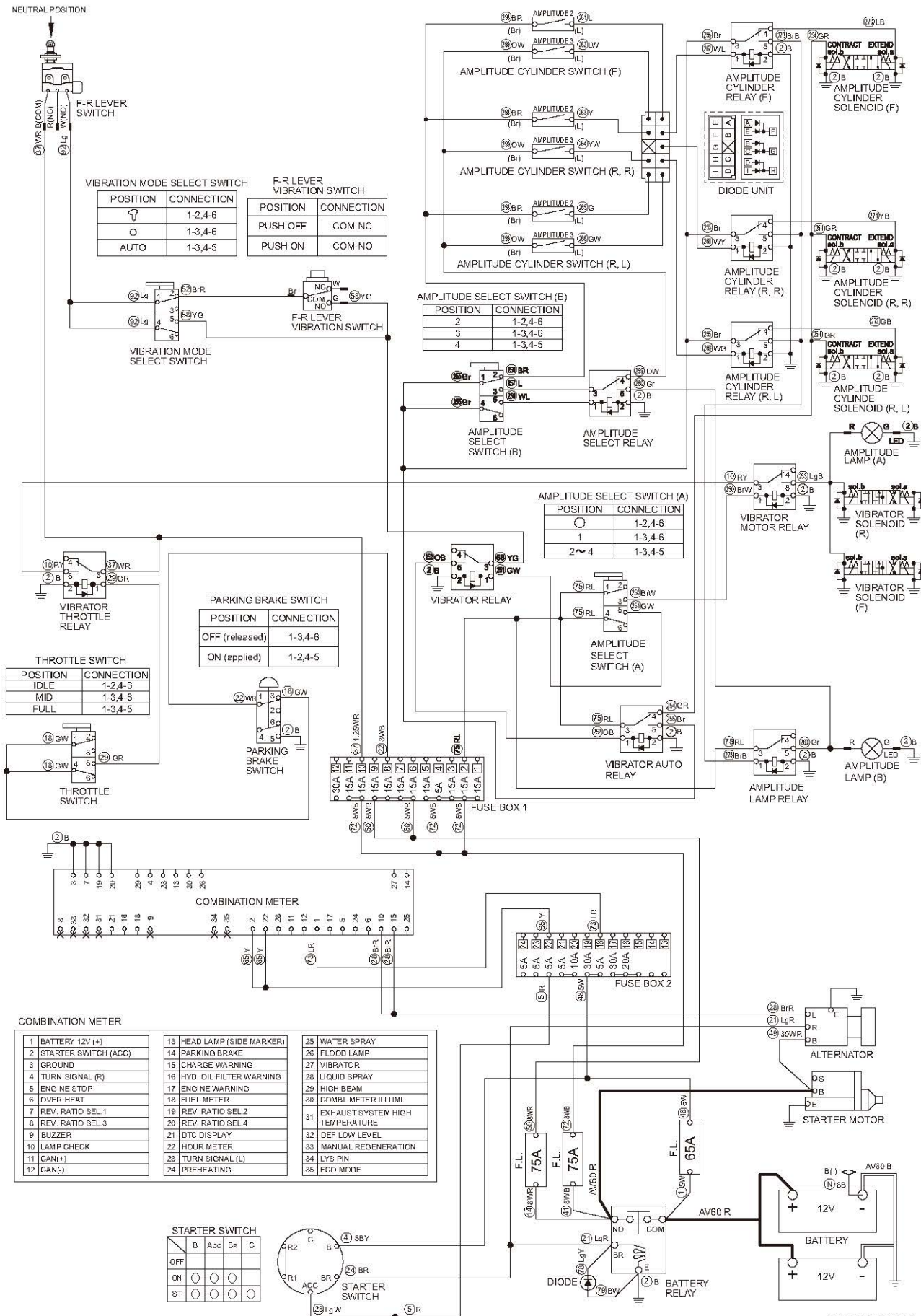

GW754-11003

2-5-3. Vibration amplitude does not change (The vibration amplitude switches only between the minimum (Amplitude 1) and the maximum (Amplitude 4)) 1/2

- Amplitude select switch (A) must be "2 ~ 4".
- Amplitude select switch (B) must be "2" or "3".
- F-R lever must be "F" or "R".
- Vibration mode select switch must be "AUTO".

Reference Fig.: 2-5-1

Check point	Check/Cause	Action
1. Amplitude Cylinder Relay (F), (R,L), (R,R)	<p>(1) When starter switch is ON, measure voltage between amplitude cylinder relay terminals 1 inlet wire WL, wire WY, wire WG and chassis ground. Standard voltage : 12 V or more</p> <p>(2) When starter switch is ON, measure voltage between amplitude cylinder relay terminals 3 inlet wire Br and chassis ground. Standard voltage : 12 V or more</p> <p>(3) When starter switch is ON, measure voltage between amplitude cylinder relay terminals 5 outlet wire BrB and chassis ground. There is electricity in normal condition.</p> <ul style="list-style-type: none"> • If above items (1) and (2) are OK and item (3) is NG, defective amplitude cylinder relay is faulty. 	Replace faulty amplitude cylinder relay.
2. Diode Unit	<p>(1) When starter switch is ON and amplitude select switch (B) is "2", measure voltage between diode unit terminal E inlet wire L, terminal B inlet wire Y, terminal D inlet wire G and chassis ground. Standard voltage : 12 V or more</p> <p>(2) When starter switch is ON and amplitude select switch (B) is "2", measure voltage between diode unit terminal F outlet wire WL, terminal G outlet wire WY, terminal H outlet wire WG and chassis ground. Standard voltage : 12 V or more</p> <p>(3) When starter switch is ON and amplitude select switch (B) is "3", measure voltage between diode unit terminal A inlet wire LW, terminal C inlet wire YW, terminal I inlet wire GW and chassis ground. Standard voltage : 12 V or more</p> <p>(4) When starter switch is ON and amplitude select switch (B) is "3", measure voltage between diode unit terminal F outlet wire WL, terminal G outlet wire WY, terminal H outlet wire WG and chassis ground. Standard voltage : 12 V or more</p> <ul style="list-style-type: none"> • If above items (1) and (3) are OK and item (2) or (4) is NG, diode unit is faulty. 	Replace diode unit.
3. Amplitude Cylinder Switch	<ul style="list-style-type: none"> • Check continuity between amplitude cylinder switch terminals. • If continuity is made and broken when amplitude select switch (B) is operated, it is normal. If not, amplitude cylinder switch is faulty 	Replace amplitude cylinder switch.

Fig.: 2-5-1

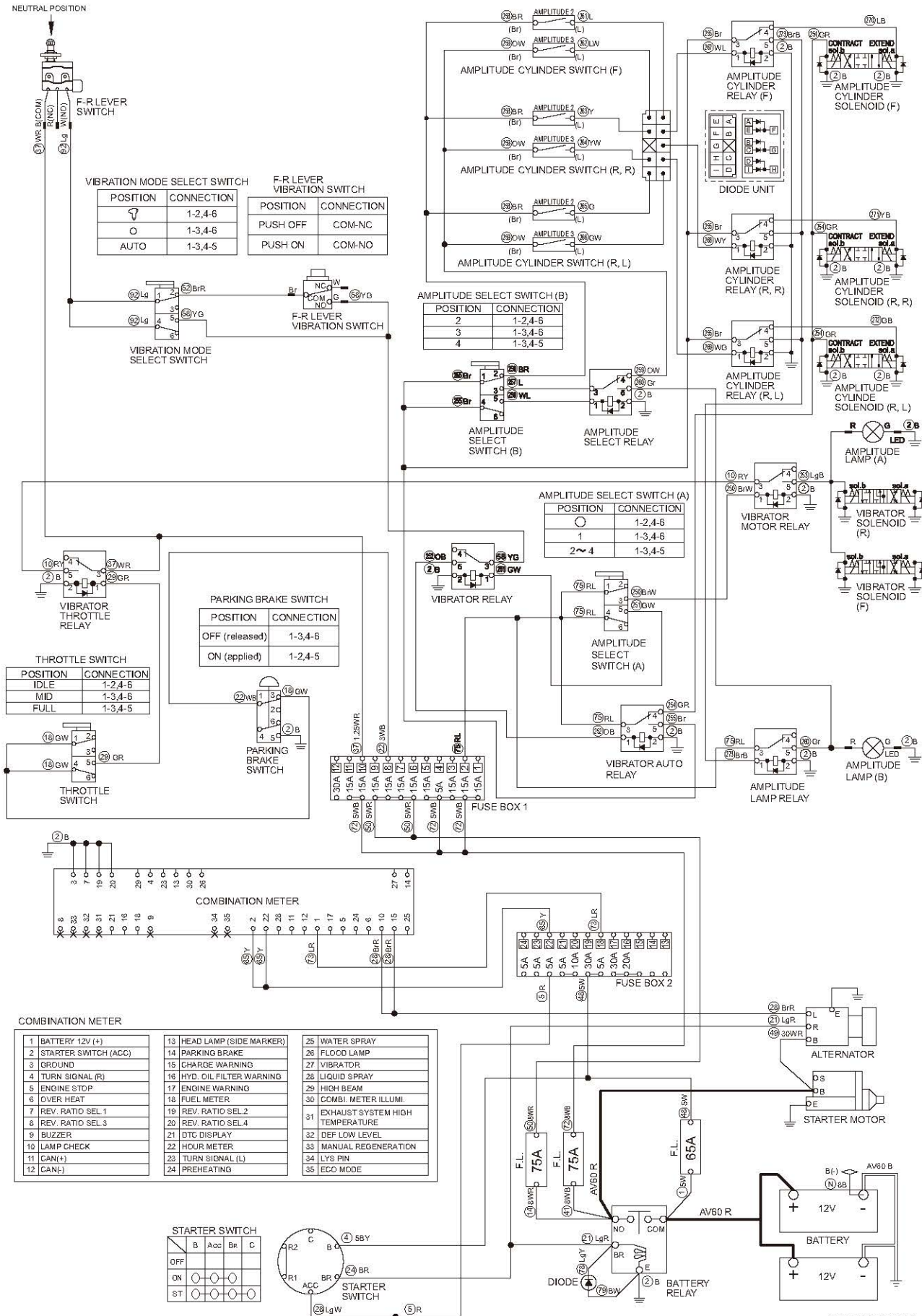

GW754-11003

2-5-3. Vibration amplitude does not change (The vibration amplitude switches only between the minimum (Amplitude 1) and the maximum (Amplitude 4)) 2/2

- Amplitude select switch (A) must be "2 ~ 4".
- Amplitude select switch (B) must be "2" or "3".
- F-R lever must be "F" or "R".
- Vibration mode select switch must be "AUTO".

Reference Fig.: 2-5-1

Check point	Check/Cause	Action
4. Amplitude Select Relay	<p>(1) When starter switch is ON and amplitude select switch (B) is "3", measure voltage between amplitude select relay terminal 1 inlet wire WL and chassis ground. There is no electricity in normal condition.</p> <p>(2) When starter switch is ON and amplitude select switch (B) is "3", measure voltage between amplitude select relay terminal 3 inlet wire L and chassis ground. Standard voltage : 12 V or more</p> <p>(3) When starter switch is ON and amplitude select switch (B) is "3", measure voltage between amplitude select relay terminal 4 outlet wire OW and chassis ground. Standard voltage : 12 V or more</p> <ul style="list-style-type: none"> • If above items (1) and (2) are OK and item (3) is NG, amplitude select relay is faulty. 	Replace amplitude select relay.
5. Amplitude Select Switch (B)	<p>(1) When starter switch is ON, measure voltage between amplitude select switch (B) terminal 1 and 4 inlet wire Br and chassis ground. Standard voltage : 12 V or more</p> <p>(2) When starter switch is ON and amplitude select switch (B) is "2", measure voltage between amplitude select switch (B) terminal 2 outlet wire BR and chassis ground. Standard voltage : 12 V or more</p> <p>(3) When starter switch is ON and amplitude select switch (B) is "3", measure voltage between amplitude select switch (B) terminal 3 outlet wire L and chassis ground. Standard voltage : 12 V or more</p> <ul style="list-style-type: none"> • If above item (1) is OK and item (2) or (3) is NG, amplitude select switch (B) is faulty. 	Replace amplitude select switch (B).
6. Harness Connecting Between Terminals	<ul style="list-style-type: none"> • Measure resistance of harness connecting between terminals. Standard resistance : 10 Ω or less • If resistance is abnormal, harness is faulty. 	Repair or replace harness.

Fig.: 2-5-1

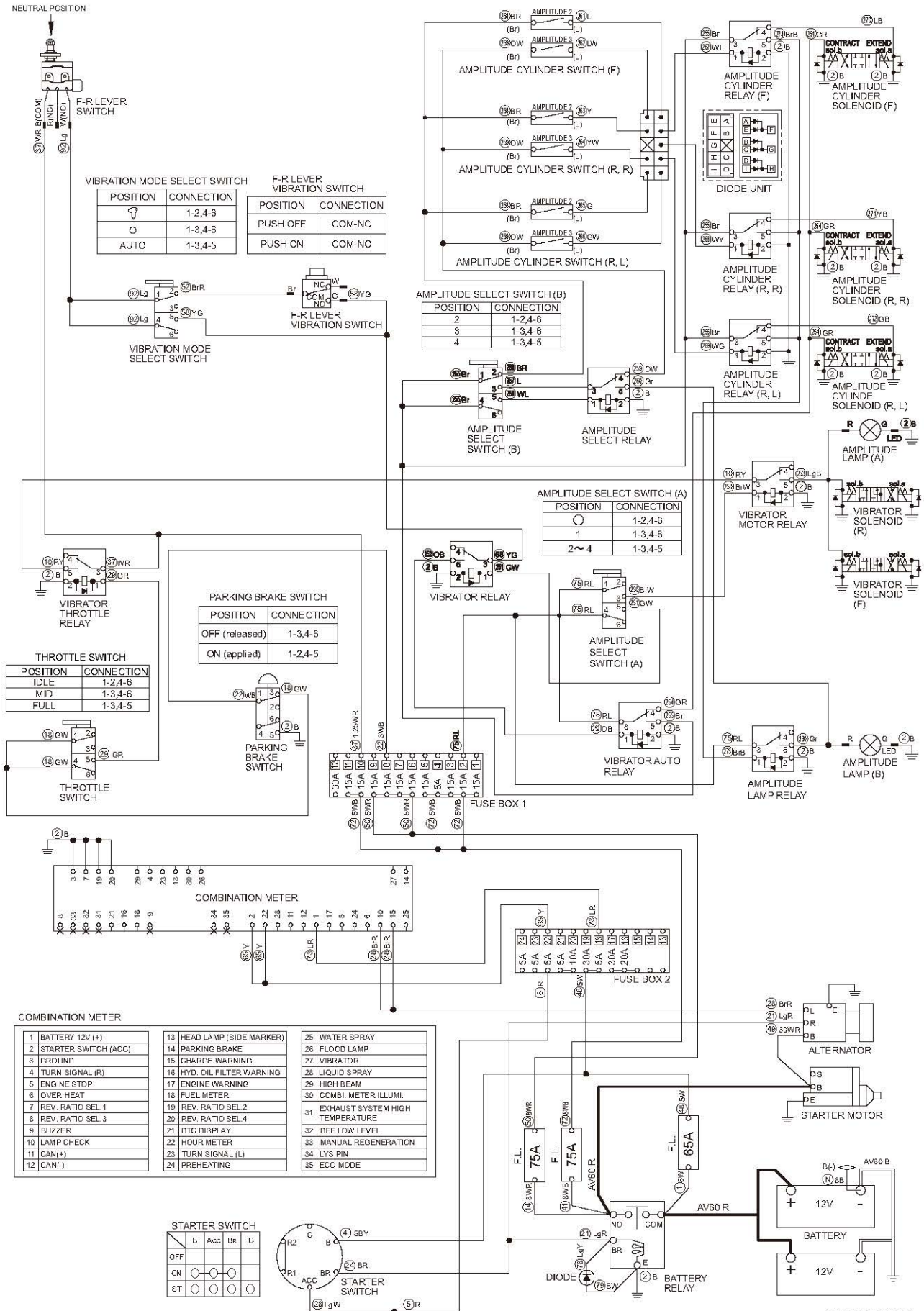

COMBINATION METER

1 BATTERY 12V (+)	13 HEAD LAMP (SIDE MARKER)	25 WATER SPRAY
2 STARTER SWITCH (ACC)	14 PARKING BRAKE	26 FLOOD LAMP
3 GROUND	15 CHARGE WARNING	27 VIBRATOR
4 TURN SIGNAL (R)	16 HYD. OIL FILTER WARNING	28 LIQUID SPRAY
5 ENGINE STOP	17 ENGINE WARNING	29 HIGH BEAM
6 OVER HEAT	18 FUEL METER	30 COMBI. METER ILLUMI.
7 REV. RATIO SEL 1	19 REV. RATIO SEL 2	31 EXHAUST SYSTEM HIGH TEMPERATURE
8 REV. RATIO SEL 3	20 REV. RATIO SEL 4	32 DEF LOW LEVEL
9 BUZZER	21 DTC DISPLAY	33 MANUAL REGENERATION
10 LAMP CHECK	22 HOUR METER	34 LYS PIN
11 CAN(+)	23 TURN SIGNAL (L)	35 ECO MODE
12 CAN(-)	24 PREHEATING	

STARTER SWITCH

OFF	B	Acc	Br	C
ON	○	○	○	○
ST	○	○	○	○

2-5-4. Vibration mode cannot be switched (F-R lever vibration switch does not work)

- F-R lever must be "F" or "R".
- Vibration mode select switch must be "T".

Reference Fig.: 2-5-1

Check point	Check/Cause	Action
1. Vibration Mode Select Switch	<p>(1) When starter switch is ON, measure voltage between vibration mode select switch terminal 1 inlet wire Lg and chassis ground. Standard voltage : 12 V or more</p> <p>(2) When starter switch is ON, measure voltage between vibration mode select switch terminal 2 outlet wire BrR and chassis ground. Standard voltage : 12 V or more</p> <ul style="list-style-type: none"> • If above item (1) is OK and item (2) is NG, vibration mode select switch is faulty. 	Replace vibration mode select switch.
2. F-R Lever Vibration Switch	<ul style="list-style-type: none"> • Check continuity between F-R lever vibration switch terminals. <ul style="list-style-type: none"> • Terminal COM and terminal NO • Terminal COM and terminal NC • If continuity is made and broken when switch is operated, it is normal. If not, switch is faulty. 	Replace F-R lever vibration switch.
3. Harness Connecting Between Terminals	<ul style="list-style-type: none"> • Measure resistance of harness connecting between terminals. Standard resistance : 10 Ω or less • If resistance is abnormal, harness is faulty. 	Repair or replace harness.

Fig.: 2-6-1

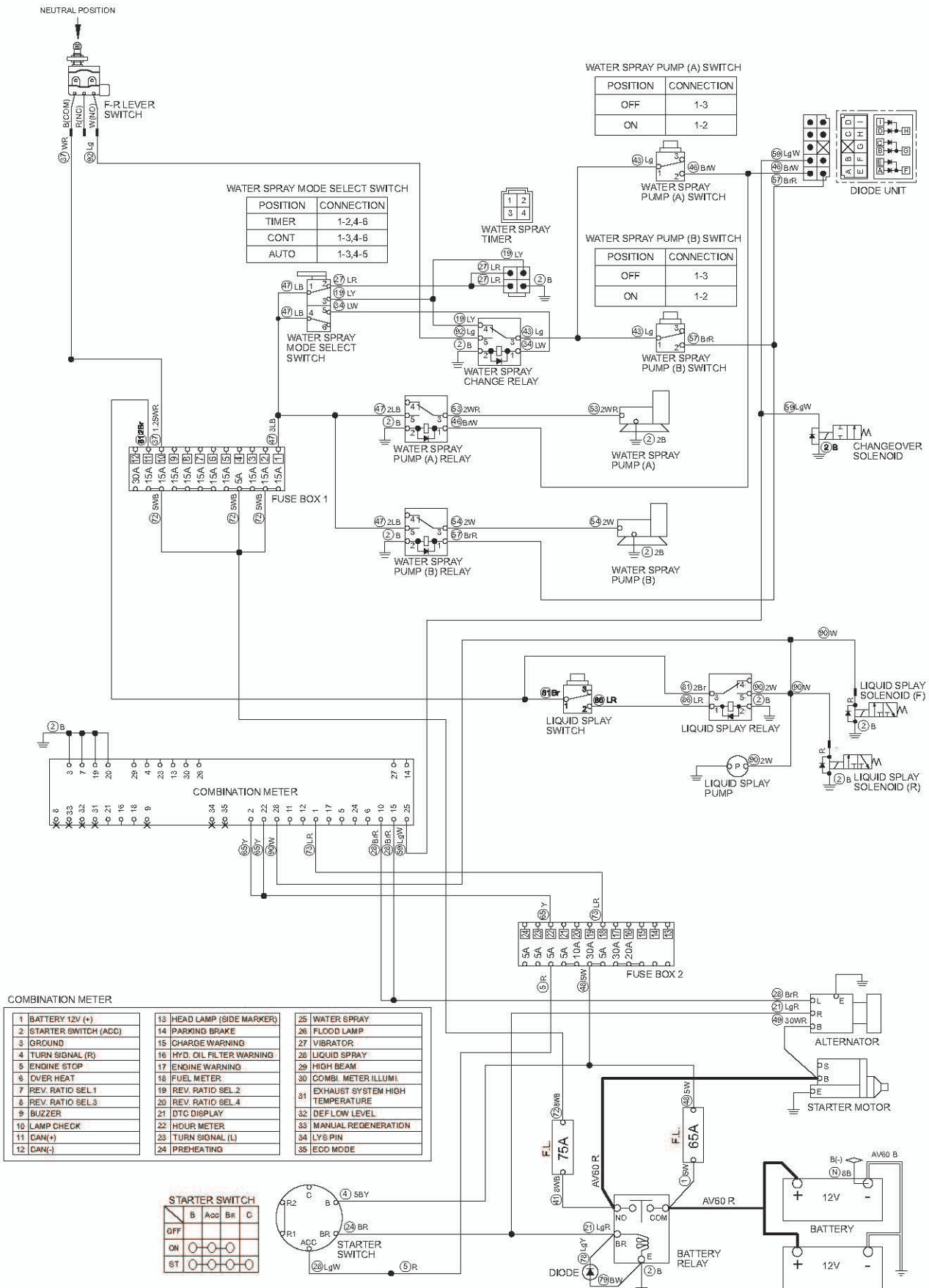

2-6. Water Spray

Check following items before troubleshooting.

- No blown fuses and power is applied up to fuses.
- Water spray pump (A) and (B) switch must be ON.
- Check any ground circuit which belongs to components to be checked.

2-6-1. Continuous water spray does not operate 1/3

- Water spray mode select switch must be "CONT".

Reference Fig.: 2-6-1

Check point	Check/Cause	Action
1. Battery	<ul style="list-style-type: none"> • Measure battery voltage or specific gravity. Standard voltage : 12 V or more Standard gravity : 1.26 or more • If value is below standard, battery capacity is insufficient. 	Charge or replace battery.
2. Water Spray Pump (A)	<ol style="list-style-type: none"> (1) When starter switch is ON, measure voltage between water spray pump (A) terminal inlet wire WR and chassis ground. Standard voltage : 12 V or more (2) Check that no abnormality is found in water spray pump (A) ground terminal. <ul style="list-style-type: none"> • If above items (1) and (2) are OK and water spray pump (A) does not operate, water spray pump (A) is faulty. 	Replace water spray pump (A).
3. Water Spray Pump (B)	<ol style="list-style-type: none"> (1) When starter switch is ON, measure voltage between water spray pump (B) terminal inlet wire W and chassis ground. Standard voltage : 12 V or more (2) Check that no abnormality is found in water spray pump (B) ground terminal. <ul style="list-style-type: none"> • If above items (1) and (2) are OK and water spray pump (B) does not operate, water spray pump (B) is faulty. 	Replace water spray pump (B).
4. Water Spray Pump (A) Relay	<ol style="list-style-type: none"> (1) When starter switch is ON, measure voltage between water spray pump (A) relay terminal 1 inlet wire BrW and chassis ground. Standard voltage : 12 V or more (2) When starter switch is ON, measure voltage between water spray pump (A) relay terminal 5 inlet wire LB and chassis ground. Standard voltage : 12 V or more (3) When starter switch is ON, measure voltage between water spray pump (A) relay terminal 3 outlet wire WR and chassis ground. Standard voltage : 12 V or more <ul style="list-style-type: none"> • If above items (1) and (2) are OK and item (3) is NG, water spray pump (A) relay is faulty. 	Replace water spray pump (A) relay.

Fig.: 2-6-1

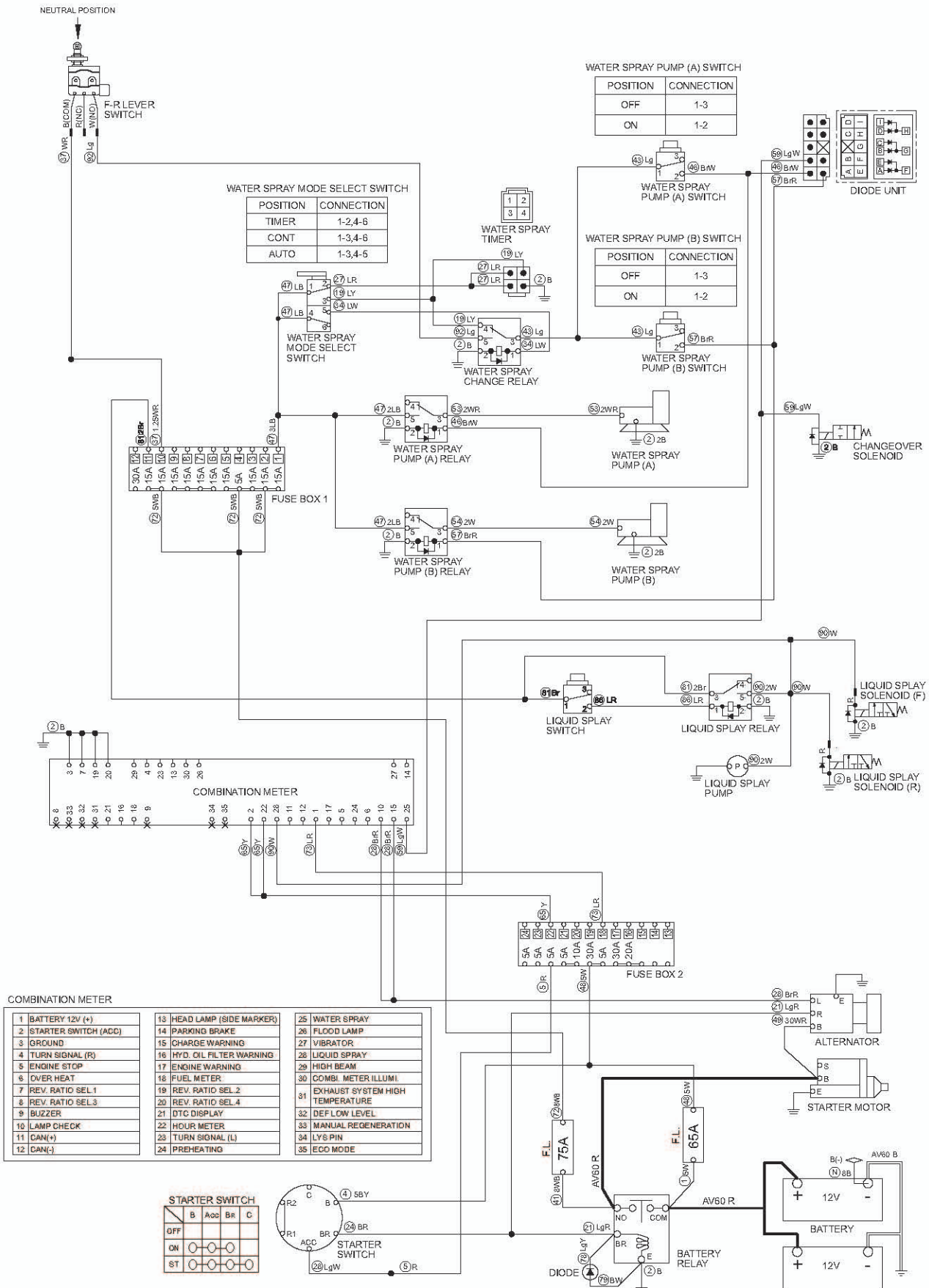

2-6-1. Continuous water spray does not operate 2/3

- Water spray mode select switch must be "CONT".

Reference Fig.: 2-6-1

Check point	Check/Cause	Action
5. Water Spray Pump (B) Relay	<p>(1) When starter switch is ON, measure voltage between water spray pump (B) relay terminal 1 inlet wire BrR and chassis ground. Standard voltage : 12 V or more</p> <p>(2) When starter switch is ON, measure voltage between water spray pump (B) relay terminal 5 inlet wire LB and chassis ground. Standard voltage : 12 V or more</p> <p>(3) When starter switch is ON, measure voltage between water spray pump (B) relay terminal 3 outlet wire W and chassis ground. Standard voltage : 12 V or more</p> <ul style="list-style-type: none"> • If above items (1) and (2) are OK and item (3) is NG, water spray pump (B) relay is faulty. 	Replace water spray pump (B) relay.
6. Water Spray Pump (A) Switch	<p>(1) When starter switch is ON, measure voltage between water spray pump (A) switch terminal 1 inlet wire Lg and chassis ground. Standard voltage : 12 V or more</p> <p>(2) When starter switch is ON, measure voltage between water spray pump (A) switch terminal 2 outlet wire BrW and chassis ground. Standard voltage : 12 V or more</p> <ul style="list-style-type: none"> • If above item (1) is OK and item (2) is NG, water spray pump (A) switch is faulty. 	Replace water spray pump (A) switch.
7. Water Spray Pump (B) Switch	<p>(1) When starter switch is ON, measure voltage between water spray pump (B) switch terminal 1 inlet wire Lg and chassis ground. Standard voltage : 12 V or more</p> <p>(2) When starter switch is ON, measure voltage between water spray pump (B) switch terminal 2 outlet wire BrR and chassis ground. Standard voltage : 12 V or more</p> <ul style="list-style-type: none"> • If above item (1) is OK and item (2) is NG, water spray pump (B) switch is faulty. 	Replace water spray pump (B) switch.
8. Water Spray Change Relay	<p>(1) When starter switch is ON, measure voltage between water spray change relay terminal 1 inlet wire LW and chassis ground. There is no electricity in normal condition.</p> <p>(2) When starter switch is ON, measure voltage between water spray change relay terminal 4 inlet wire LY and chassis ground. Standard voltage : 12 V or more</p> <p>(3) When starter switch is ON, measure voltage between water spray change relay terminal 3 outlet wire Lg and chassis ground. Standard voltage : 12 V or more</p> <ul style="list-style-type: none"> • If above items (1) and (2) are OK and item (3) is NG, water spray change relay is faulty. 	Replace water spray change relay.

Fig.: 2-6-1

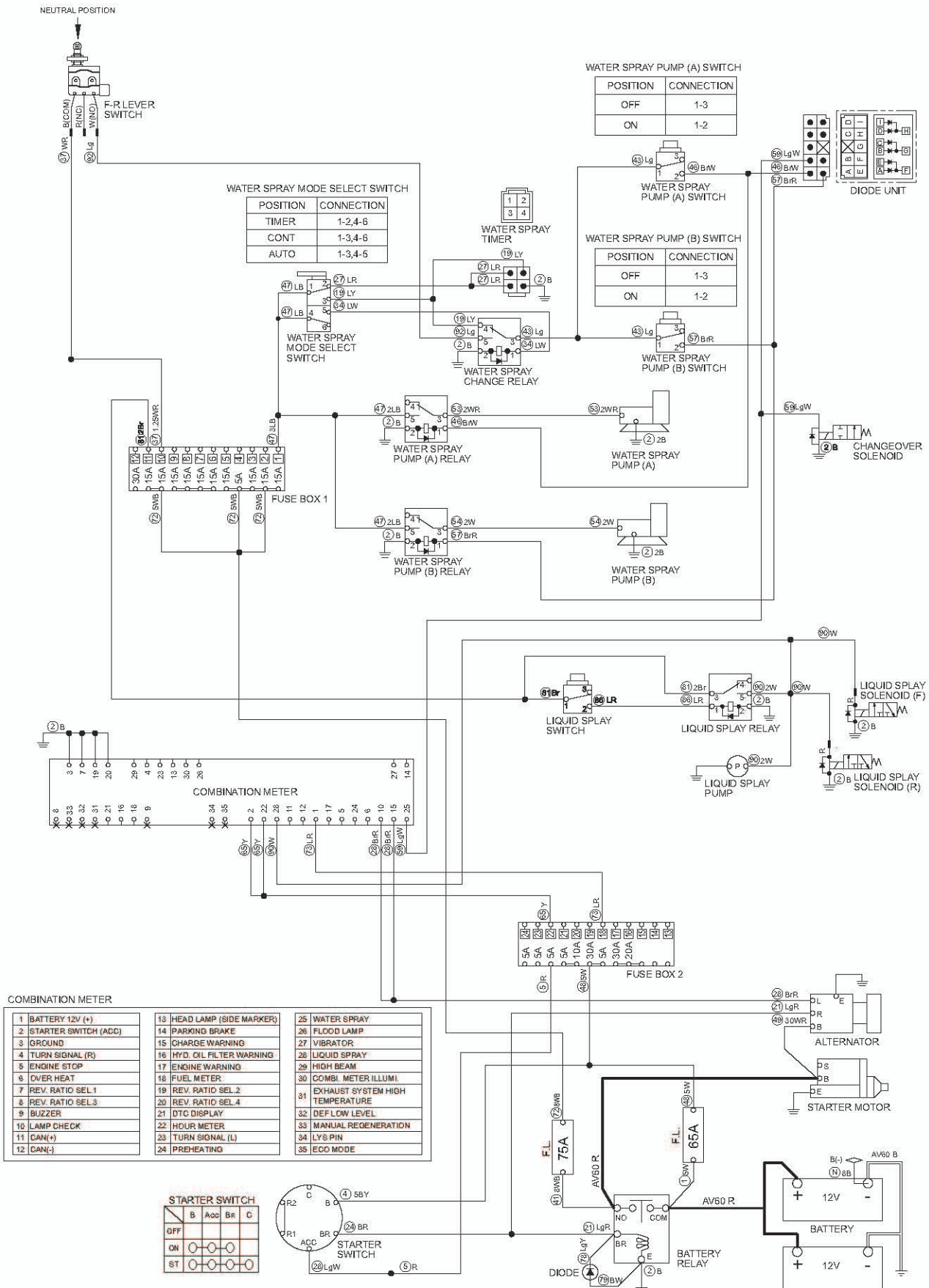

2-6-1. Continuous water spray does not operate 3/3

- Water spray mode select switch must be "CONT".

Reference Fig.: 2-6-1

Check point	Check/Cause	Action
9. Water Spray Mode Select Switch	(1) When starter switch is ON, measure voltage between water spray mode select switch terminal 1 inlet wire LB and chassis ground. Standard voltage : 12 V or more (2) When starter switch is ON, measure voltage between water spray mode select switch terminal 3 outlet wire LY and chassis ground. Standard voltage : 12 V or more • If above item (1) is OK and item (2) is NG, water spray mode select switch is faulty.	Replace water spray mode select switch.
10. Harness Connecting Between Terminals	• Measure resistance of harness connecting between terminals. Standard resistance : 10 Ω or less • If resistance is abnormal, harness is faulty.	Repair or replace harness.

Fig.: 2-6-1

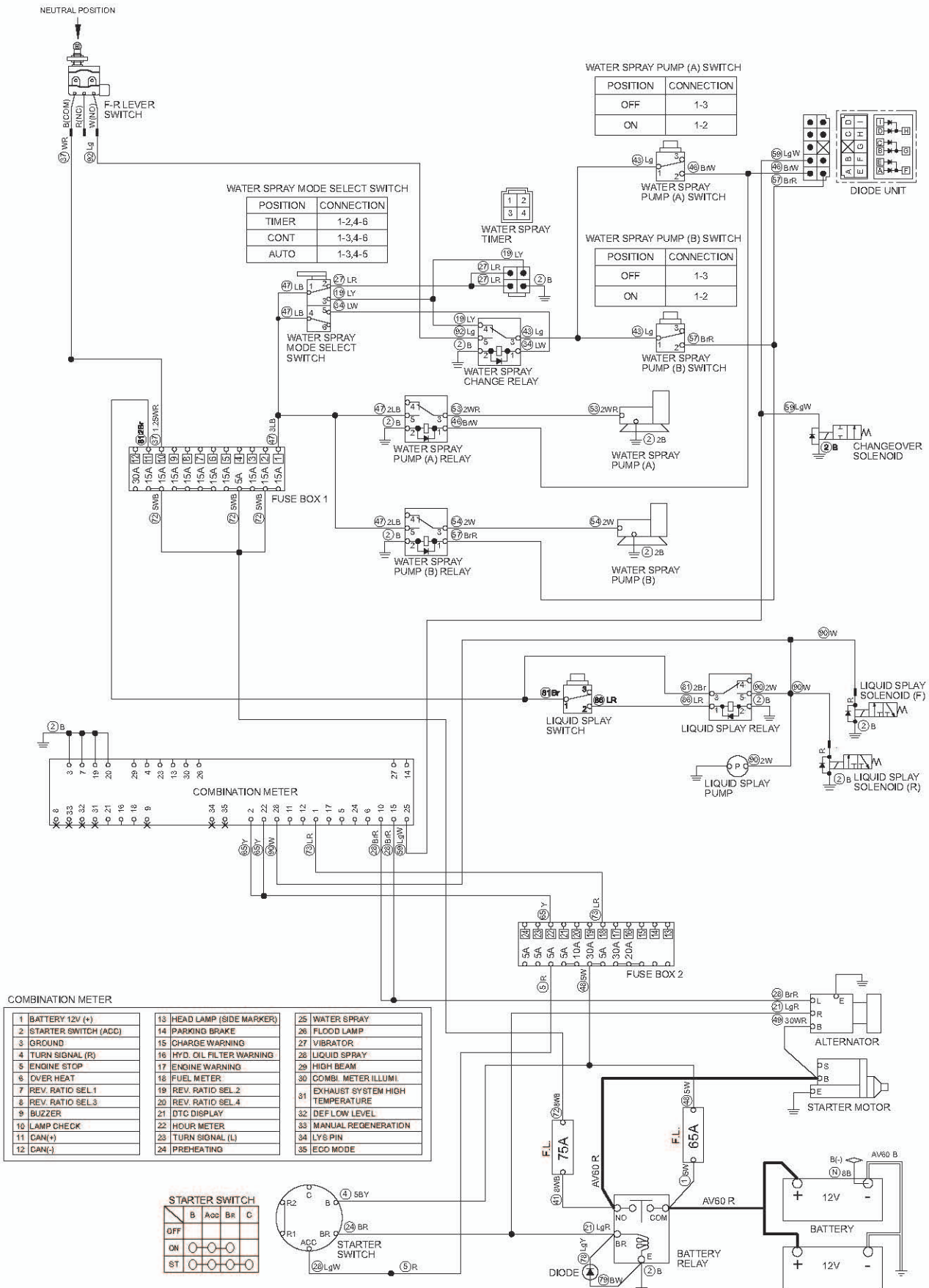

2-6-2. Continuous water spray works, but auto water spray does not operate

- F-R lever must be "F" or "R".
- Water spray mode select switch must be "AUTO".

Reference Fig.: 2-6-1

Check point	Check/Cause	Action
1. Water Spray change Relay	<p>(1) When starter switch is ON, measure voltage between water spray change relay terminal 1 inlet wire LW and chassis ground. Standard voltage : 12 V or more</p> <p>(2) When starter switch is ON, measure voltage between water spray change relay terminal 5 inlet wire Lg and chassis ground. Standard voltage : 12 V or more</p> <p>(3) When starter switch is ON, measure voltage between water spray change relay terminal 3 outlet wire Lg and chassis ground. Standard voltage : 12 V or more</p> <ul style="list-style-type: none"> • If above items (1) and (2) are OK and item (3) is NG, water spray change relay is faulty. 	Replace water spray change relay.
2. Water Spray Mode Select Switch	<p>(1) When starter switch is ON, measure voltage between water spray mode select switch terminal 4 inlet wire LB and chassis ground. Standard voltage : 12 V or more</p> <p>(2) When starter switch is ON, measure voltage between water spray mode select switch terminal 5 outlet wire LW and chassis ground. Standard voltage : 12 V or more</p> <ul style="list-style-type: none"> • If above item (1) is OK and item (2) is NG, water spray mode select switch is faulty. 	Replace water spray mode select switch.
3. Harness Connecting Between Terminals	<ul style="list-style-type: none"> • Measure resistance of harness connecting between terminals. Standard resistance : 10 Ω or less • If resistance is abnormal, harness is faulty. 	Repair or replace harness.

Fig.: 2-6-1

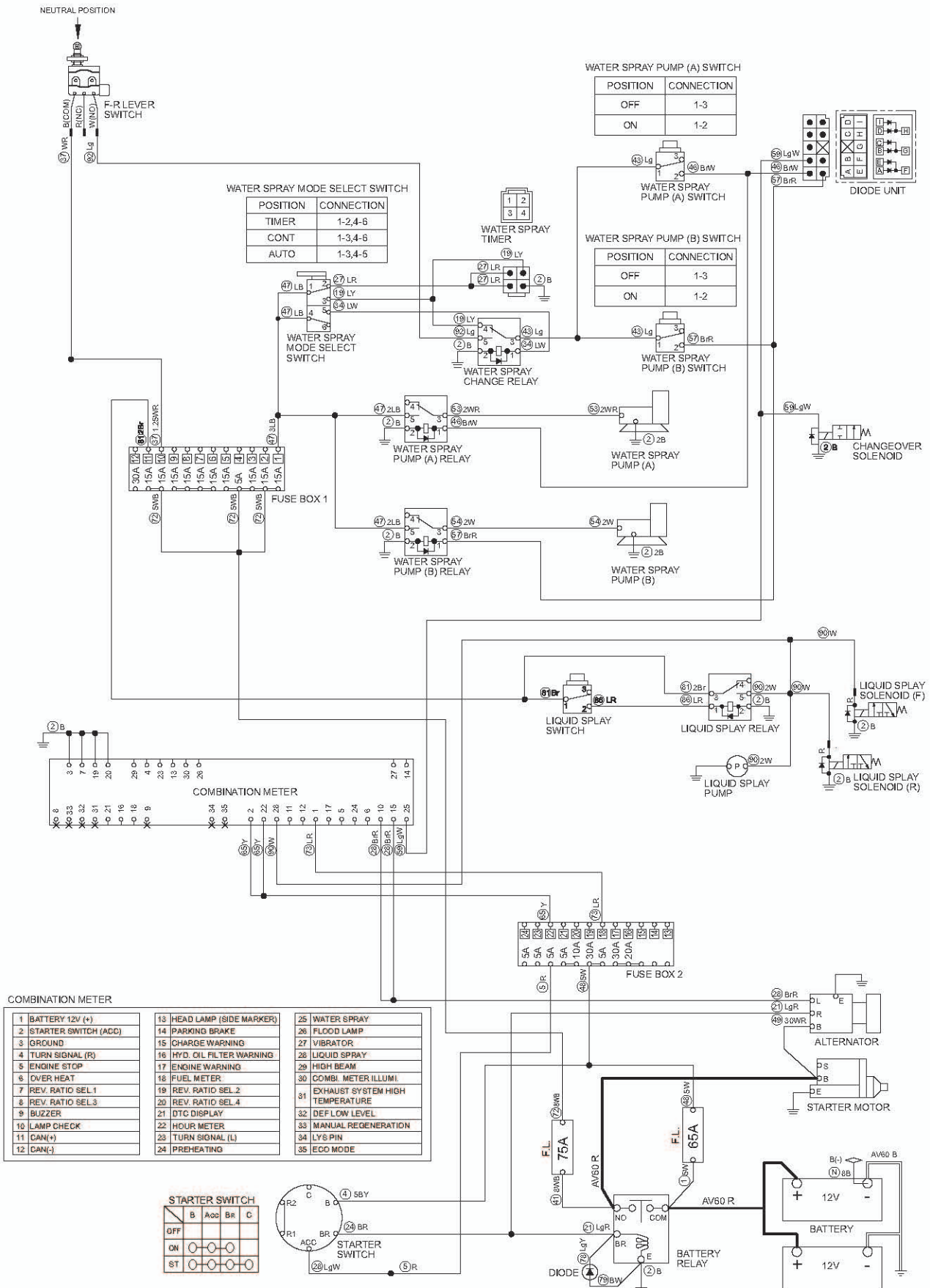

2-6-3. Continuous water spray works, but intermittent water spray does not operate

- Water spray mode select switch must be "TIMER".

Reference Fig. : 2-6-1

Check point	Check/Cause	Action
1. Water Spray Timer	<p>(1) When starter switch is ON, measure voltage between water spray timer terminal 1 and 3 inlet wire LR and chassis ground. Standard voltage : 12 V or more</p> <p>(2) When starter switch is ON, measure voltage between water spray timer terminal 4 outlet wire LY and chassis ground. Standard voltage : 12 V or more (Electricity flows for a definite time.)</p> <ul style="list-style-type: none"> • If above item (1) is OK and item (2) is NG, water spray timer is faulty. 	Replace water spray timer.
2. Water Spray mode Select Switch	<p>(1) When starter switch is ON, measure voltage between water spray mode select switch terminal 1 inlet wire LB and chassis ground. Standard voltage : 12 V or more</p> <p>(2) When starter switch is ON, measure voltage between water spray mode select switch terminal 2 outlet wire LR and chassis ground. Standard voltage : 12 V or more</p> <ul style="list-style-type: none"> • If above item (1) is OK and item (2) is NG, water spray mode select switch is faulty. 	Replace water spray mode select switch.
3. Harness Connecting Between Terminals	<ul style="list-style-type: none"> • Measure resistance of harness connecting between terminals. Standard resistance : 10 Ω or less • If resistance is abnormal, harness is faulty. 	Repair or replace harness.

Fig.: 2-6-1

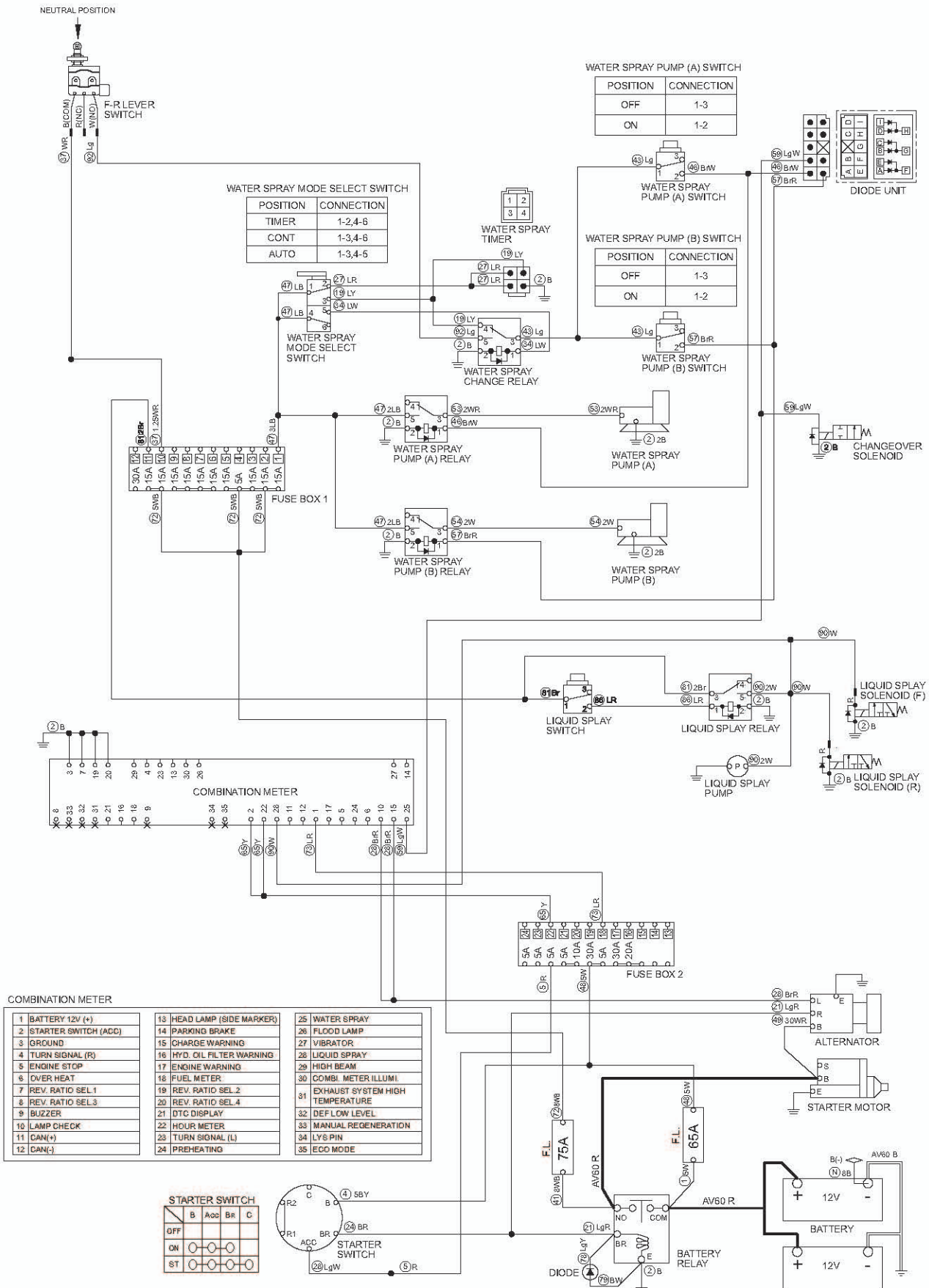

2-6-4. Water is not supplied from water spray tank (R)

- Water spray mode select switch must be "CONT".

Reference Fig.: 2-6-1

Check point	Check/Cause	Action
1. Diode Unit	(1) When starter switch is ON and water spray pump (A) switch is ON, measure voltage between diode unit terminal E inlet wire BrW and chassis ground. Standard voltage : 12 V or more (2) When starter switch is ON and water spray pump (B) switch is ON, measure voltage between diode unit terminal A inlet wire BrR and chassis ground. Standard voltage : 12 V or more (3) When starter switch is ON and water spray pump (A) switch or (B) switch is ON, measure voltage between diode unit terminal F outlet wire LgW and chassis ground. Standard voltage : 12 V or more • If above items (1) and (2) are OK and item (3) is NG, diode unit is faulty.	Replace diode unit
2. Changeover Solenoid	• Disconnect harness and measure resistance of coil. Standard resistance : 13.7 Ω • If measured resistance is abnormal, changeover solenoid is faulty.	Replace changeover solenoid

Fig.: 2-6-1

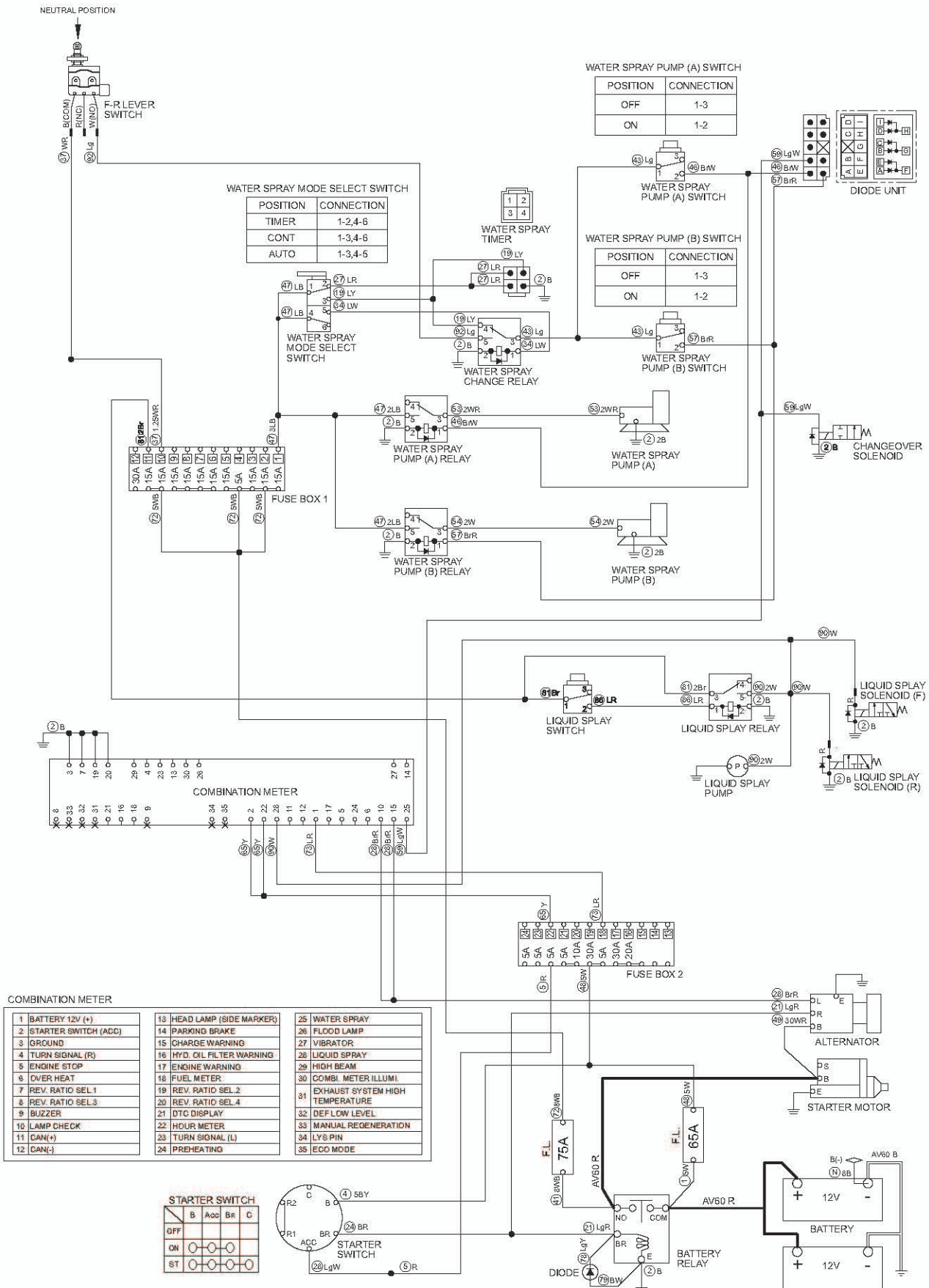

2-6-5. Liquid cannot be sprayed

Reference Fig. : 2-6-1

Check point	Check/Cause	Action
1. Liquid Spray Pump	<ul style="list-style-type: none"> • When starter switch is ON and liquid spray switch pressed, measure voltage between liquid spray pump terminal inlet wire W and chassis ground. Standard voltage : 12 V or more • If above item is OK and liquid spray pump does not operate, liquid spray pump is faulty. 	Replace liquid spray pump. (Because remained liquid may dry and accrete to lock pump shaft, check with a screw driver that pump shaft rotates before replacing pump.)
2. Liquid Spray Solenoid	<ul style="list-style-type: none"> • Disconnect harness and measure resistance of coil. Standard resistance : 32 Ω • If measured resistance is abnormal, liquid spray solenoid is faulty. 	Replace liquid spray solenoid.
3. Liquid Spray Relay	<p>(1) When starter switch is ON and liquid spray switch pressed, measure voltage between liquid spray relay terminal 1 inlet wire LR and chassis ground. Standard voltage : 12 V or more</p> <p>(2) When starter switch is ON, measure voltage between liquid spray relay terminal 3 inlet wire Br and chassis ground. Standard voltage : 12 V or more</p> <p>(3) When starter switch is ON and liquid spray switch pressed, measure voltage between liquid spray relay terminal 5 outlet wire W and chassis ground. Standard voltage : 12 V or more</p> <ul style="list-style-type: none"> • If above items (1) and (2) are OK and item (3) is NG, liquid spray relay is faulty. 	Replace liquid spray relay.
4. Liquid Spray Switch	<ul style="list-style-type: none"> • When liquid spray switch is ON, check continuity between liquid switch terminals. There is continuity in normal condition. • If there is no continuity, liquid spray switch is faulty. 	Replace liquid spray switch.
5. Harness Connecting Between Terminals	<ul style="list-style-type: none"> • Measure resistance of harness connecting between terminals. Standard resistance : 10 Ω or less • If resistance is abnormal, harness is faulty. 	Repair or replace harness.

Fig.: 2-7-1

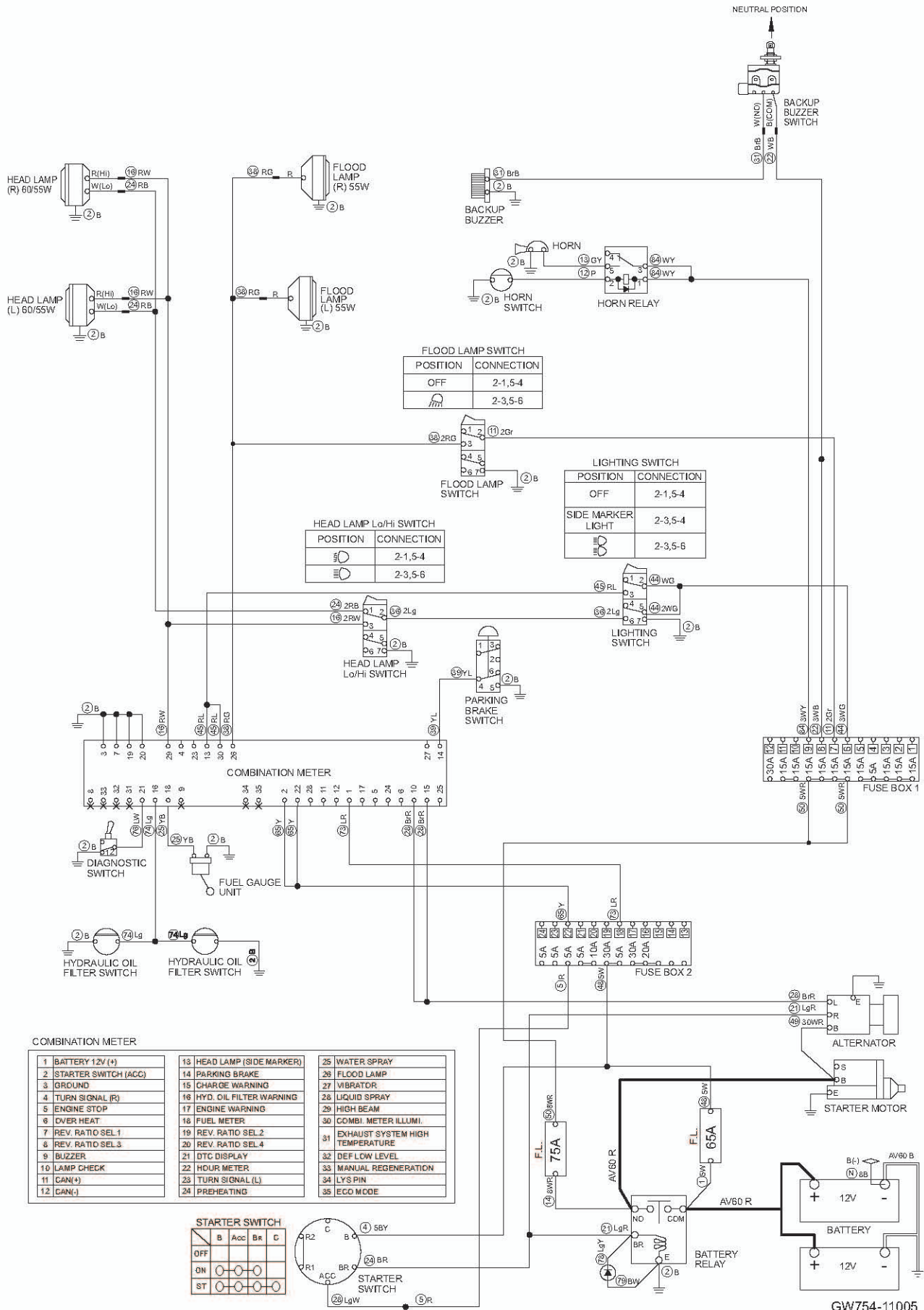

GW754-11005

2-7. Lighting

Check following items before troubleshooting.

- No blown fuse and power is applied up to fuses.

2-7-1. Head lamp does not light

Reference Fig. : 2-7-1





Check point	Check/Cause	Action
1. Battery	<ul style="list-style-type: none"> • Measure battery voltage or specific gravity. Standard voltage : 12 V or more Standard gravity : 1.26 or more • If value is below standard, battery capacity is insufficient. 	Charge or replace battery.
2. Each Bulb	<ul style="list-style-type: none"> • Check that none of lamp bulbs is burned out or has a contact failure. • Bulb is faulty or poorly connected. 	Replace each bulb.
3. Lighting Switch	<p>(1) When starter switch is ON, measure voltage between lighting switch terminal 2 and 5 inlet wire WG and chassis ground. Standard voltage : 12 V or more</p> <p>(2) When starter switch is ON and lighting switch is "SIDE MARKER LIGHT", measure voltage between lighting switch terminal 3 outlet wire RL and chassis ground. Standard voltage : 12 V or more</p> <p>(3) When starter switch is ON and lighting switch is "  ", measure voltage between lighting switch terminal 6 outlet wire Lg and chassis ground. Standard voltage : 12 V or more</p> <ul style="list-style-type: none"> • If above item (1) is OK and item (2) or (3) is NG, lighting switch is faulty. 	Replace lighting switch.
4. Head lamp Lo/Hi Switch	<p>(1) When starter switch is ON and lighting switch is "  ", measure voltage between ighting Lo/Hi switch terminal 2 inlet wire Lg and chassis ground. Standard voltage : 12 V or more</p> <p>(2) When starter switch is ON, lighting switch is "  " and head lamp Lo/Hi switch is "  ", measure voltage between head lamp Lo/Hi switch terminal 1 outlet wire RB and chassis ground. Standard voltage : 12 V or more</p> <ul style="list-style-type: none"> • If above item (1) is OK and item (2) is NG, head lamp Lo/Hi switch is faulty. 	Replace head lamp Lo/Hi switch.
5. Harness Connecting Between Terminals	<ul style="list-style-type: none"> • Measure resistance of harness connecting between terminals. Standard resistance : 10 Ω or less • If resistance is abnormal, harness is faulty. 	Repair or replace harness.

Fig.: 2-7-1



GW754-11005

2-7-2. Flood lamp does not light

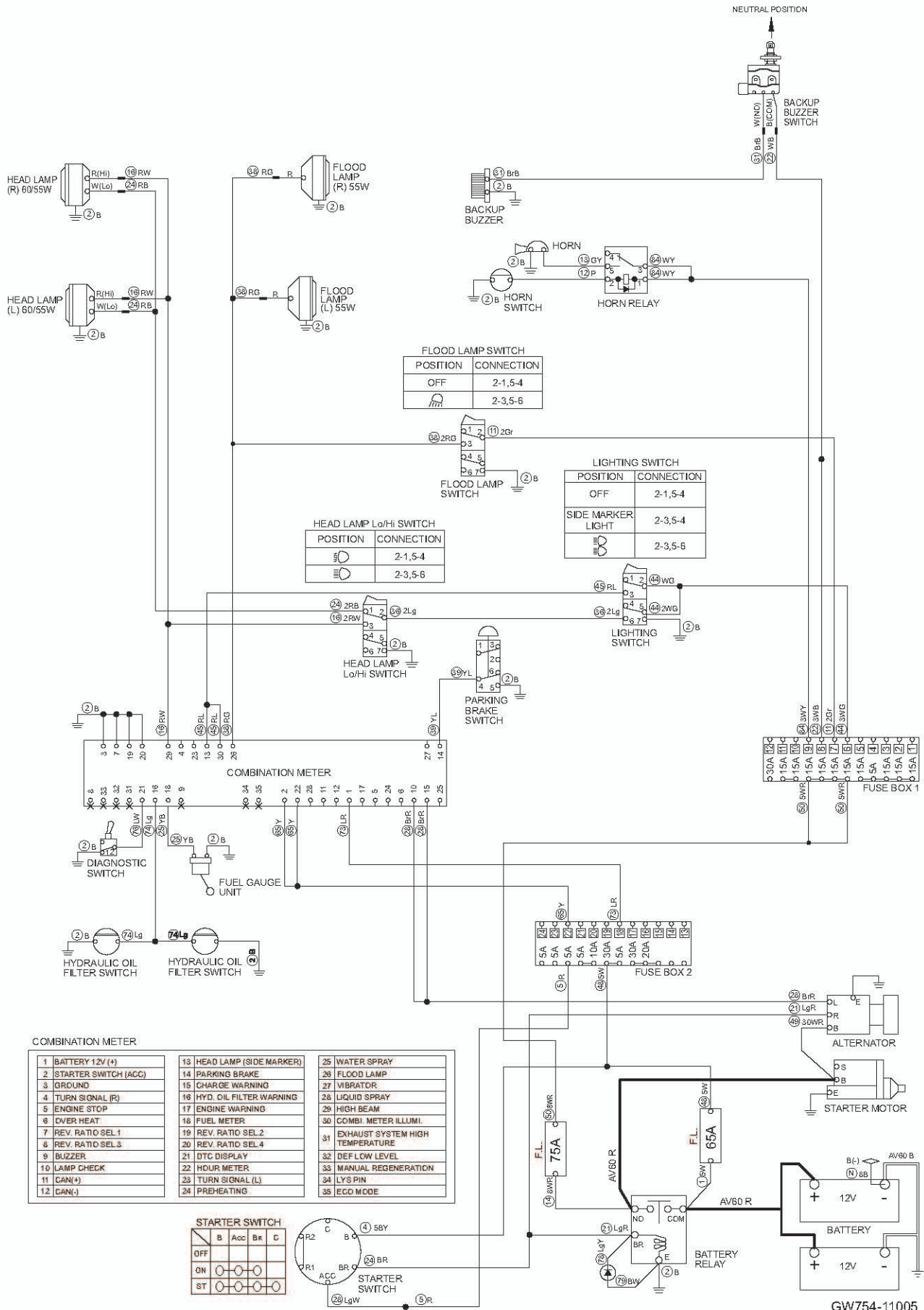
Reference Fig. : 2-7-1

Check point	Check/Cause	Action
1. Each Bulb	<ul style="list-style-type: none"> • Check that none of lamp bulbs is burned out or has a contact failure. • Bulb is faulty or poorly connected. 	Replace each bulb.
2. Flood Lamp Switch	<p>(1) When starter switch is ON, measure voltage between flood lamp switch terminal 2 inlet wire Gr and chassis ground. Standard voltage : 12 V or more</p> <p>(2) When starter switch is ON and flood lamp switch is "", measure voltage between flood lamp switch terminal 3 outlet wire RG and chassis ground. Standard voltage : 12 V or more</p> <ul style="list-style-type: none"> • If above item (1) is OK and item (2) is NG, flood lamp switch is faulty. 	Replace flood lamp switch.
3. Harness Connecting Between Terminals	<ul style="list-style-type: none"> • Measure resistance of harness connecting between terminals. Standard resistance : 10 Ω or less • If resistance is abnormal, harness is faulty. 	Repair or replace harness.

2-7-3. High-beam of head lamp does not light

Reference Fig. : 2-7-1



Check point	Check/Cause	Action
1. Each Bulb	<ul style="list-style-type: none"> • Check that none of lamp bulbs is burned out or has a contact failure. • Bulb is faulty or poorly connected. 	Replace each bulb.
2. Head lamp Lo/Hi Switch	<p>(1) When starter switch is ON and lighting switch is "", measure voltage between head lamp Lo/Hi switch terminal 2 inlet wire Lg and chassis ground. Standard voltage : 12 V or more</p> <p>(2) When starter switch is ON, lighting switch is "" and head lamp Lo/Hi switch is "", measure voltage between head lamp Lo/Hi switch terminal 3 outlet wire RW and chassis ground. Standard voltage : 12 V or more</p> <ul style="list-style-type: none"> • If above item (1) is OK and item (2) is NG, turn signal switch is faulty. 	Replace head lamp Lo/Hi switch.
3. Harness Connecting Between Terminals	<ul style="list-style-type: none"> • Measure resistance of harness connecting between terminals. Standard resistance : 10 Ω or less • If resistance is abnormal, harness is faulty. 	Repair or replace harness.

Fig.: 2-7-1



GW754-11005

2-7-4. Illumination of combination meter does not light

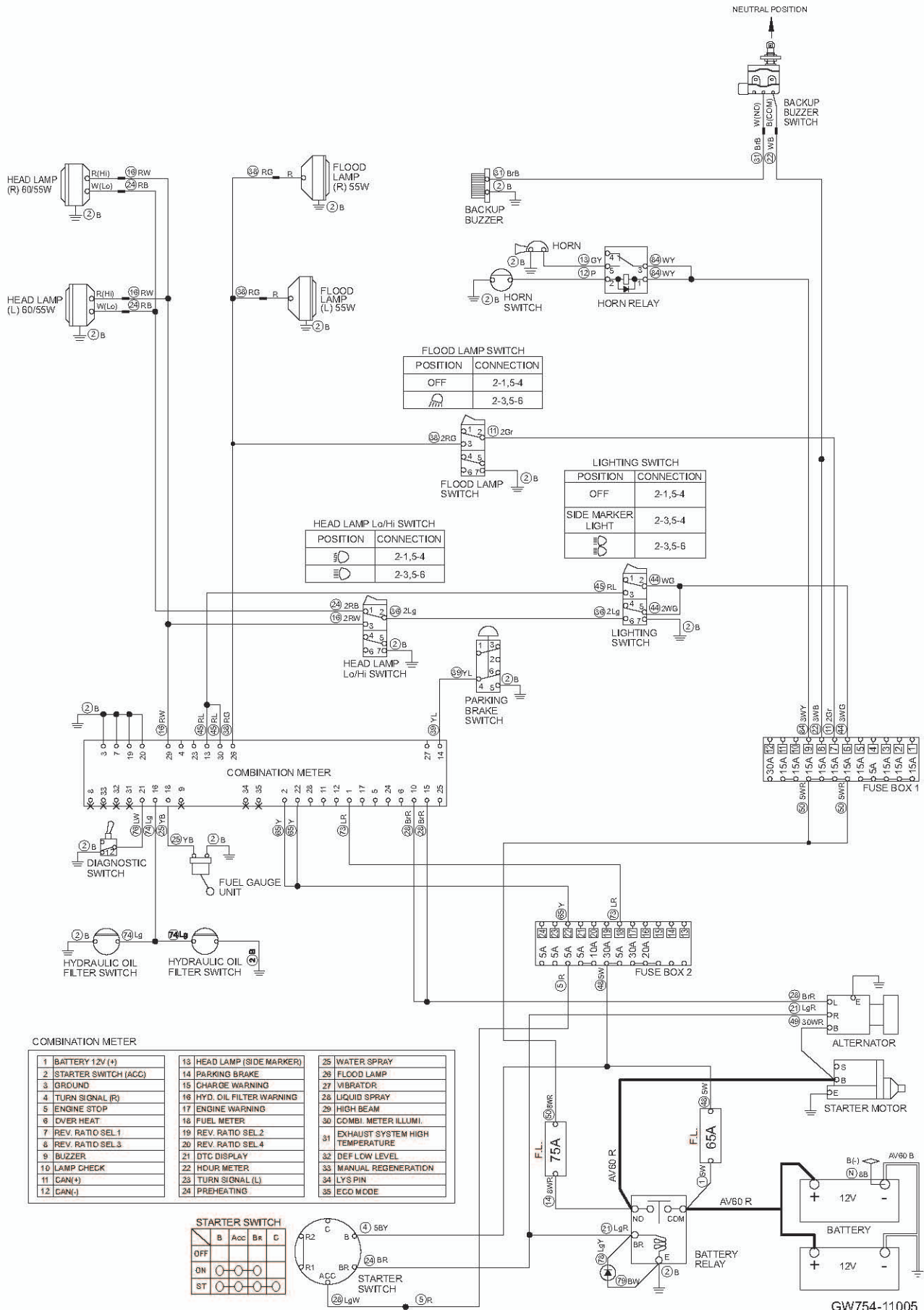
Reference Fig. : 2-7-1

Check point	Check/Cause	Action
1. Harness	<ul style="list-style-type: none"> • Measure resistance between lighting switch terminal 3 wire RL and combination meter connector terminal wire No.45 wire RL. Standard resistance : 10 Ω or less • If resistance is abnormal, harness is faulty. 	Repair or replace harness.
2. Combination Meter (Combination meter illumination)	<p>(1) When starter switch is ON, measure voltage between combination meter terminal wires and ground terminal wire.</p> <ul style="list-style-type: none"> • Battery 12 V (+) terminal wire No.73 inlet wire LR and ground terminal wire No.2 wire B • Starter switch (ACC) terminal wire No.65 inlet wire Y and ground terminal wire No.2 wire B <p>Standard voltage : 12 V or more</p> <p>(2) When starter switch is ON and lighting switch is "SIDE MARKER LIGHT", measure voltage between combination meter illumination terminal wire No.45 inlet wire RL and chassis ground. Standard voltage : 12 V or more</p> <ul style="list-style-type: none"> • If above items (1) and (2) are OK and combination meter does not turn on, combination meter is faulty. 	Replace combination meter.

2-7-5. Combination meter warning lamp or indicator lamp is abnormal

Reference Fig. : 2-7-1

Check point	Check/Cause	Action
1. Harness	<ul style="list-style-type: none"> • Measure resistance between alternator terminal L wire BrR and combination meter connector terminal wire No.28 wire BrR. Standard resistance : 10 Ω or less • If resistance is abnormal, harness is faulty. 	Repair or replace harness.
2. Combination Meter (Lamp check)	<p>(1) When starter switch is ON, measure voltage between combination meter terminal wires and ground terminal wire.</p> <ul style="list-style-type: none"> • Battery 12 V (+) terminal wire No.73 inlet wire LR and ground terminal wire No.2 wire B • Starter switch (ACC) terminal wire No.65 inlet wire Y and ground terminal wire No.2 wire B <p>Standard voltage : 12 V or more</p> <p>(2) When starter switch is ON, check that parking brake indicator lamp, hydraulic oil filter warning lamp, engine oil pressure warning lamp and charge warning lamp illuminate and then go out after starting engine.</p> <ul style="list-style-type: none"> • If above item (1) is OK and item (2) is NG, combination meter is faulty. <p>(NOTICE)</p> <ul style="list-style-type: none"> • Since engine cannot start unless parking brake switch is applied, parking brake indicator lamp does not go out even after starting engine. 	Replace combination meter.

Fig.: 2-7-1

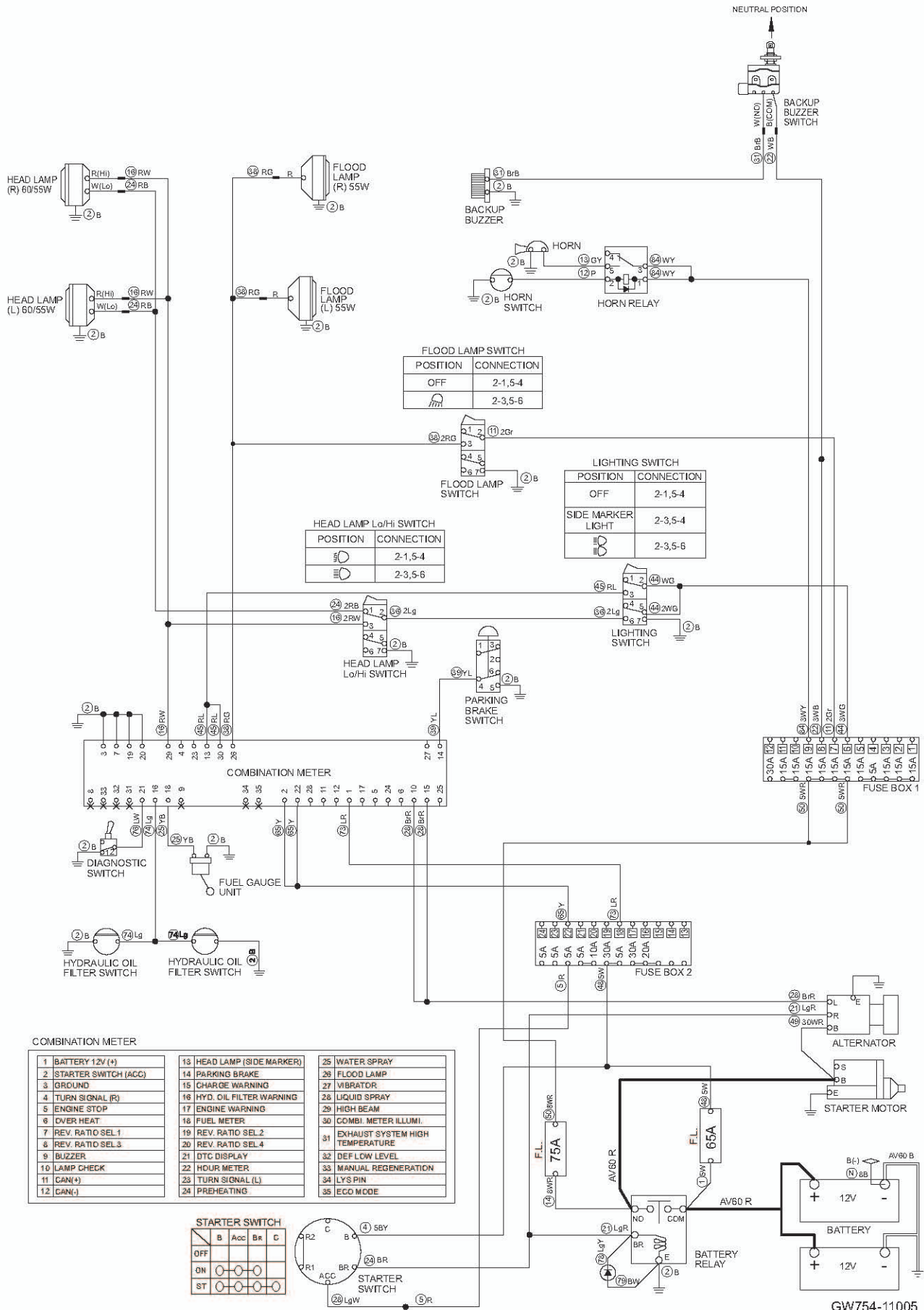

GW754-11005

2-7-6. Tachometer reading is abnormal

Reference Fig. : 2-7-1

Check point	Check/Cause	Action
1. Combination Meter (Tachometer)	<ul style="list-style-type: none"> • When starter switch is ON, measure voltage between combination meter terminal wires and ground terminal wire. <ul style="list-style-type: none"> • Battery 12 V (+) terminal wire No.73 inlet wire LR and ground terminal wire No.2 wire B • Starter switch (ACC) terminal wire No.65 inlet wire Y and ground terminal wire No.2 wire B Standard voltage : 12 V or more • If no abnormality is found, combination meter is faulty. 	Replace combination meter.

2-7-7. Hour meter is abnormal

Reference Fig. : 2-7-1

Check point	Check/Cause	Action
1. Combination Meter (Hour meter)	<ul style="list-style-type: none"> • When starter switch is ON, measure voltage between combination meter terminal wires and ground terminal wire. <ul style="list-style-type: none"> • Battery 12 V (+) terminal wire No.73 inlet wire LR and ground terminal wire No.2 wire B • Hour meter terminal wire No.65 inlet wire Y and ground terminal wire No.2 wire B Standard voltage : 12 V or more • If no abnormality is found, combination meter is faulty. 	Replace combination meter.

Fig.: 2-7-1

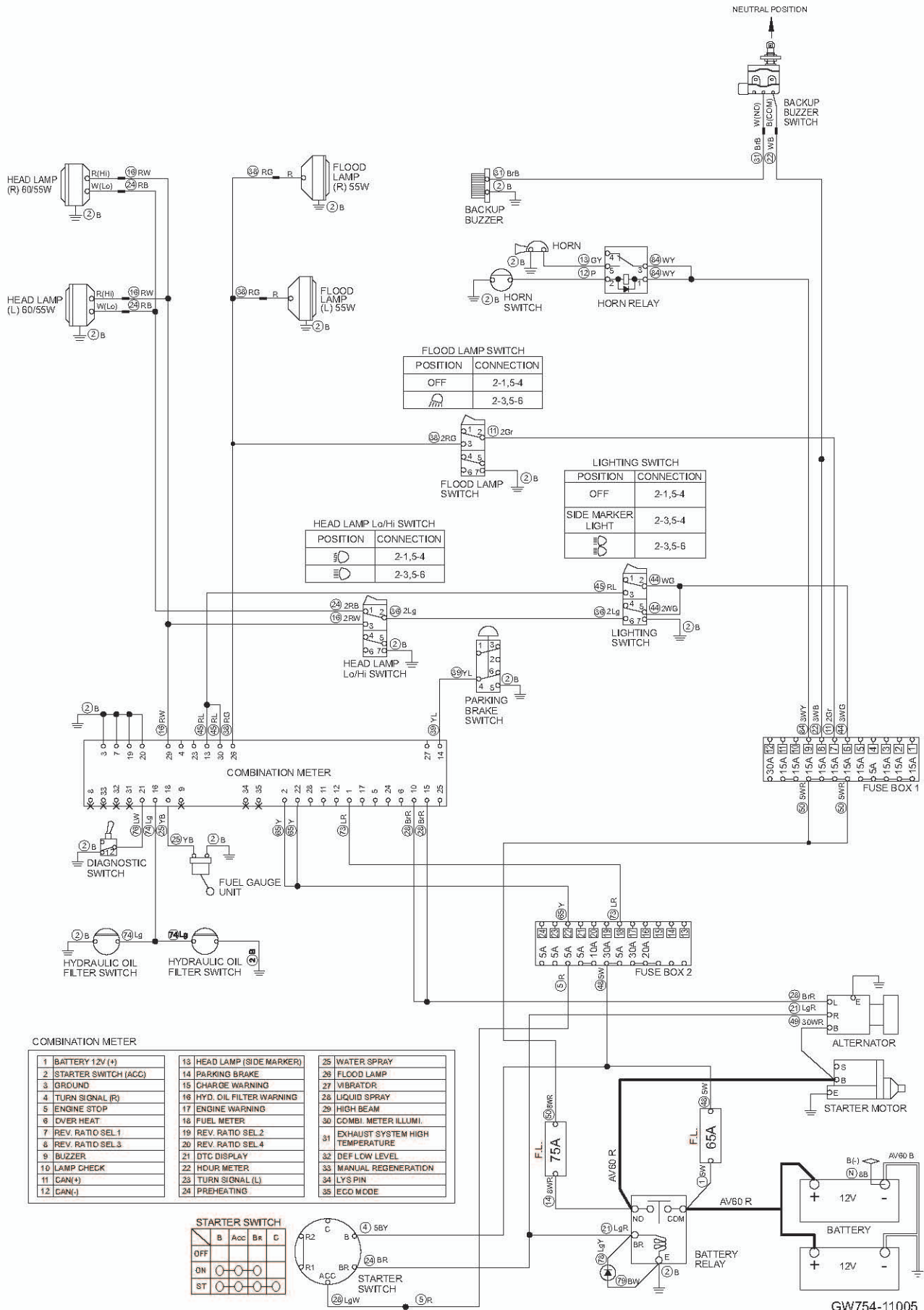

GW754-11005

2-7-8. Temperature meter is abnormal**Reference Fig. : 2-7-1**

Check point	Check/Cause	Action
1. Combination Meter (Temperature meter)	<ul style="list-style-type: none"> • When starter switch is ON, measure voltage between combination meter terminal wires and ground terminal wire. <ul style="list-style-type: none"> • Battery 12 V (+) terminal wire No.73 inlet wire LR and ground terminal wire No.2 wire B • Starter switch (ACC) terminal wire No.65 inlet wire Y and ground terminal wire No.2 wire B Standard voltage : 12 V or more • If no abnormality is found, combination meter is faulty. 	Replace combination meter.

2-7-9. Fuel meter is abnormal**Reference Fig. : 2-7-1**

Check point	Check/Cause	Action
1. Fuel Gauge Unit	<ul style="list-style-type: none"> • Disconnect harness and measure resistance of fuel gauge unit. Standard resistance : 13.5 Ω (with float in "F") 80.0 Ω (with float in "E") • If resistance is abnormal, fuel gauge unit is faulty. 	Replace fuel gauge unit.
2. Combination Meter (Fuel meter)	<p>(1) When starter switch is ON, measure voltage between combination meter terminal wires and ground terminal wire.</p> <ul style="list-style-type: none"> • Battery 12 V (+) terminal wire No.73 inlet wire LR and ground terminal wire No.2 wire B • Starter switch (ACC) terminal wire No.65 inlet wire Y and ground terminal wire No.2 wire B <p>Standard voltage : 12 V or more</p> <p>(2) When starter switch is ON, measure voltage between fuel meter terminal wire No.25 outlet wire YB and ground terminal wire.</p> <p>Standard voltage : 12 V or more</p> <ul style="list-style-type: none"> • If above items (1) and (2) are OK and fuel meter is abnormal, combination meter is faulty. 	Replace combination meter.
3. Harness Connecting Between Terminals	<ul style="list-style-type: none"> • Measure resistance of harness connecting between terminals. Standard resistance : 10 Ω or less • If resistance is abnormal, harness is faulty. 	Repair or replace harness.

Fig.: 2-7-1

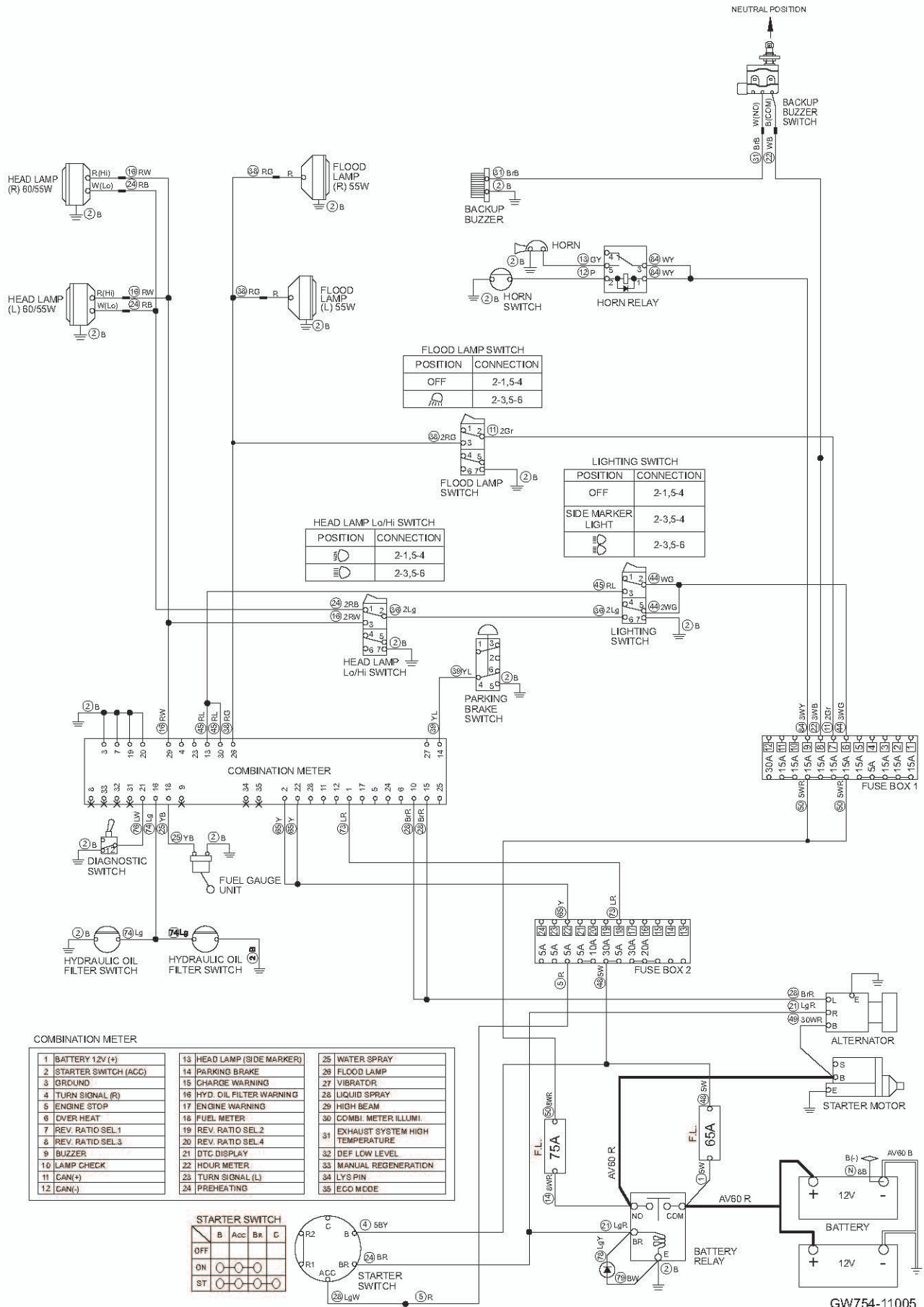

GW754-11005

2-7-10. Hydraulic oil filter warning lamp remains ON

Reference Fig. : 2-7-1

Check point	Check/Cause	Action
1. Harness	<ul style="list-style-type: none"> • Disconnect connectors between combination meter and hydraulic oil filter switch. • Measure resistance between terminals and chassis ground. <ul style="list-style-type: none"> • Hydraulic oil filter switch terminals wire Lg and chassis ground. • Combination meter connector terminal wire No.74 wire Lg and chassis ground. Standard resistance : 100k Ω or more • If resistance is abnormal, harness is faulty. 	Repair or replace harness.
2. Hydraulic Oil Filter Switch	<ul style="list-style-type: none"> • When starter switch is OFF, check continuity between hydraulic oil filter switch inlet terminal wire Lg and chassis ground. There is no continuity in normal condition. • If there is continuity, hydraulic oil filter switch is faulty. 	Replace hydraulic oil filter switch.
3. Combination Meter (Hydraulic oil filter warning)	<p>(1) When starter switch is ON, measure voltage between combination meter terminal wires and ground terminal wire.</p> <ul style="list-style-type: none"> • Battery terminal wire No.73 inlet wire LR and ground terminal wire No.2 wire B. • Starter switch (ACC) terminal wire No.65 inlet wire Y and ground terminal wire No.2 wire B. Standard voltage : 12 V or more <p>(2) When starter switch is ON, measure voltage between combination meter hydraulic oil filter warning terminal outlet wire No.74 wire Lg and chassis ground. Standard voltage : 12 V or more</p> <ul style="list-style-type: none"> • If above items (1) and (2) are OK but hydraulic oil filter warning lamp remains on after starting engine, combination meter is faulty. 	Replace combination meter.

2-7-11. Charge warning lamp remains ON

- Check with engine running.

Reference Fig. : 2-7-1

Check point	Check/Cause	Action
1. Harness	<ul style="list-style-type: none"> • Disconnect connectors between combination meter and alternator terminal L. • Measure resistance between terminals and chassis ground. <ul style="list-style-type: none"> • Combination meter connector terminal wire No.28 wire BrR and chassis ground. • Alternator terminal L wire BrR and chassis ground Standard resistance : 100k Ω or more • If resistance is abnormal, harness is faulty. 	Repair or replace harness.
2. Combination Meter (Charge warning lamp)	<ul style="list-style-type: none"> • Measure voltage between combination meter charge warning terminal wire No.28 outlet wire BrR and chassis ground. Standard voltage : 12 V or more • If no abnormality is found, combination meter is faulty. 	Replace combination meter.

Fig.: 2-6-1

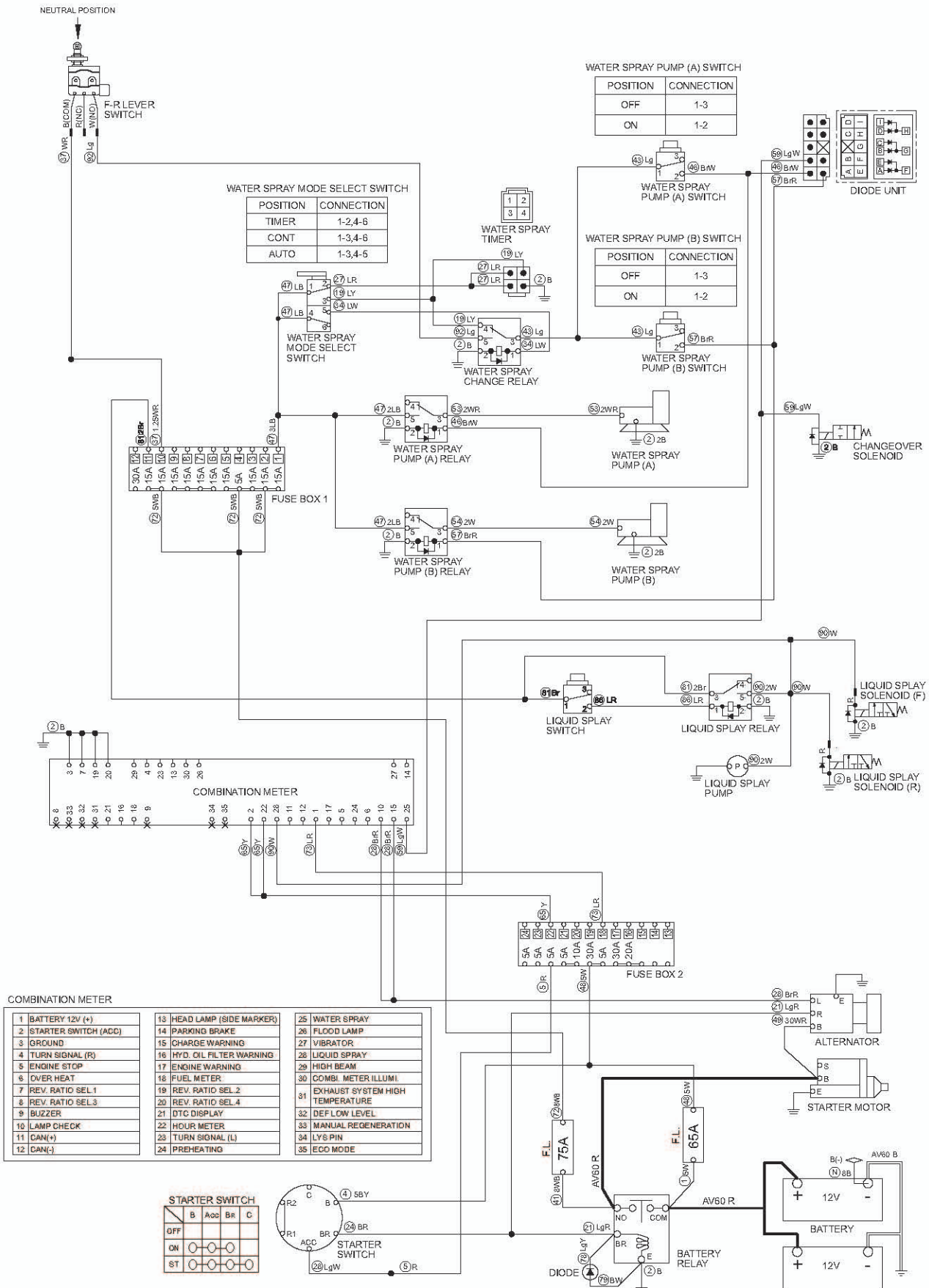

2-7-12. Water spray indicator lamp does not light

- Check that water spray pump can be activated.
- Water spray mode select switch must be "CONT".

Reference Fig. : 2-6-1

Check point	Check/Cause	Action
1. Harness	<p>(1) Measure resistance between water spray pump (A) switch terminal 2 wire BrW and diode unit terminal E wire BrW. Standard resistance : 10 Ω or less</p> <p>(2) Measure resistance between water spray pump (B) switch terminal 2 wire BrR and diode unit terminal A wire BrR. Standard resistance : 10 Ω or less</p> <p>(3) Measure resistance between diode unit terminal F wire LgW and combination meter connector terminal wire No. 59 wire LgW. Standard resistance : 10 Ω or less</p> <ul style="list-style-type: none"> • If above item (1) , (2) or (3) is NG, defective harness is faulty. 	Repair or replace faulty harness.
2. Diode Unit	<p>(1) When starter switch is ON and water spray pump (A) switch is ON, measure voltage between diode unit terminal E inlet wire BrW and chassis ground. Standard voltage : 12 V or more</p> <p>(2) When starter switch is ON and water spray pump (B) switch is ON, measure voltage between diode unit terminal A inlet wire BrR and chassis ground. Standard voltage : 12 V or more</p> <p>(3) When starter switch is ON and water spray pump (A) switch or (B) switch is ON, measure voltage between diode unit terminal F outlet wire LgW and chassis ground. Standard voltage : 12 V or more</p> <ul style="list-style-type: none"> • If above items (1) and (2) are OK and item (3) is NG, diode unit is faulty. 	Replace diode unit.
3. Combination Meter (Water spray indicator lamp)	<p>(1) When starter switch is ON, measure voltage between combination meter terminal wires and ground terminal wire.</p> <ul style="list-style-type: none"> • Battery 12 V (+) terminal wire No.73 inlet wire LR and ground terminal wire No.2 wire B • Starter switch (ACC) terminal wire No.65 inlet wire Y and ground terminal wire No.2 wire B <p>Standard voltage : 12 V or more</p> <p>(2) When starter switch is ON and water spray pump (A) switch or (B) switch is ON, measure voltage between combination meter water spray terminal wire No.59 inlet wire LgW and chassis ground. Standard voltage : 12 V or more</p> <ul style="list-style-type: none"> • If above items (1) and (2) are OK and water spray indicator lamp does not light, combination meter is faulty. 	Replace combination meter.

Fig.: 2-6-1

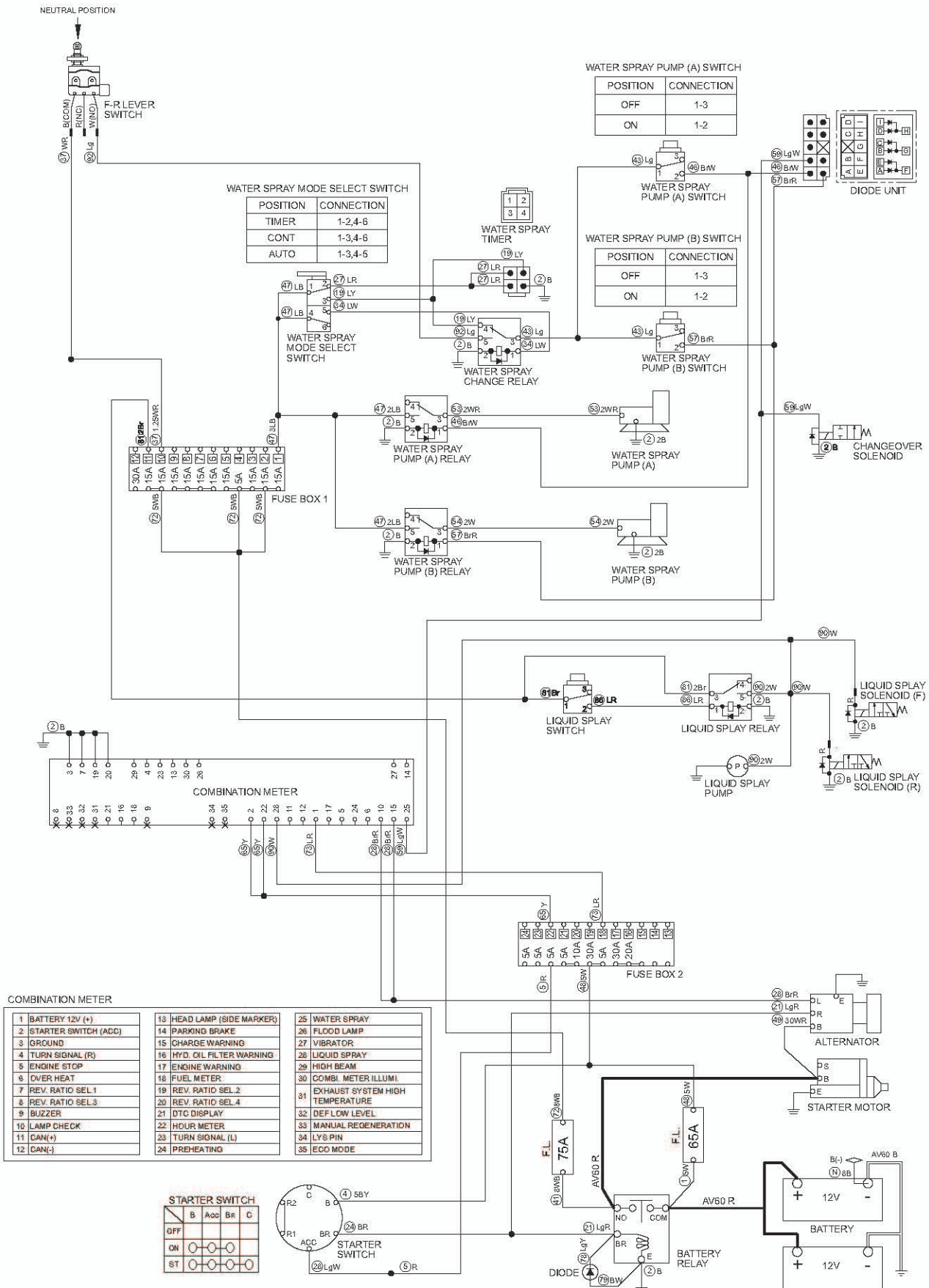

2-7-13. Liquid spray indicator lamp does not light

- Check that liquid spray pump can be activated.

Reference Fig. : 2-6-1

Check point	Check/Cause	Action
1. Harness	<ul style="list-style-type: none"> • Measure resistance between liquid spray relay terminal 5 wire W and combination meter connector terminal wire No.90 wire W. Standard resistance : 10 Ω or less • If resistance is abnormal, harness is faulty. 	Repair or replace harness.
2. Combination Meter (Liquid spray indicator lamp)	<p>(1) When starter switch is ON, measure voltage between combination meter terminal wires and ground terminal wire.</p> <ul style="list-style-type: none"> • Battery 12 V (+) terminal wire No.73 inlet wire LR and ground terminal wire No.2 wire B • Starter switch (ACC) terminal wire No.65 inlet wire Y and ground terminal wire No.2 wire B <p>Standard voltage : 12 V or more</p> <p>(2) When starter switch is ON and liquid spray switch pressed, measure voltage between combination meter liquid spray terminal wire No.90 inlet wire W and chassis ground.</p> <p>Standard voltage : 12 V or more</p> <ul style="list-style-type: none"> • If above items (1) and (2) are OK and liquid spray indicator lamp does not light, combination meter is faulty. 	Replace combination meter.

Fig.: 2-7-1

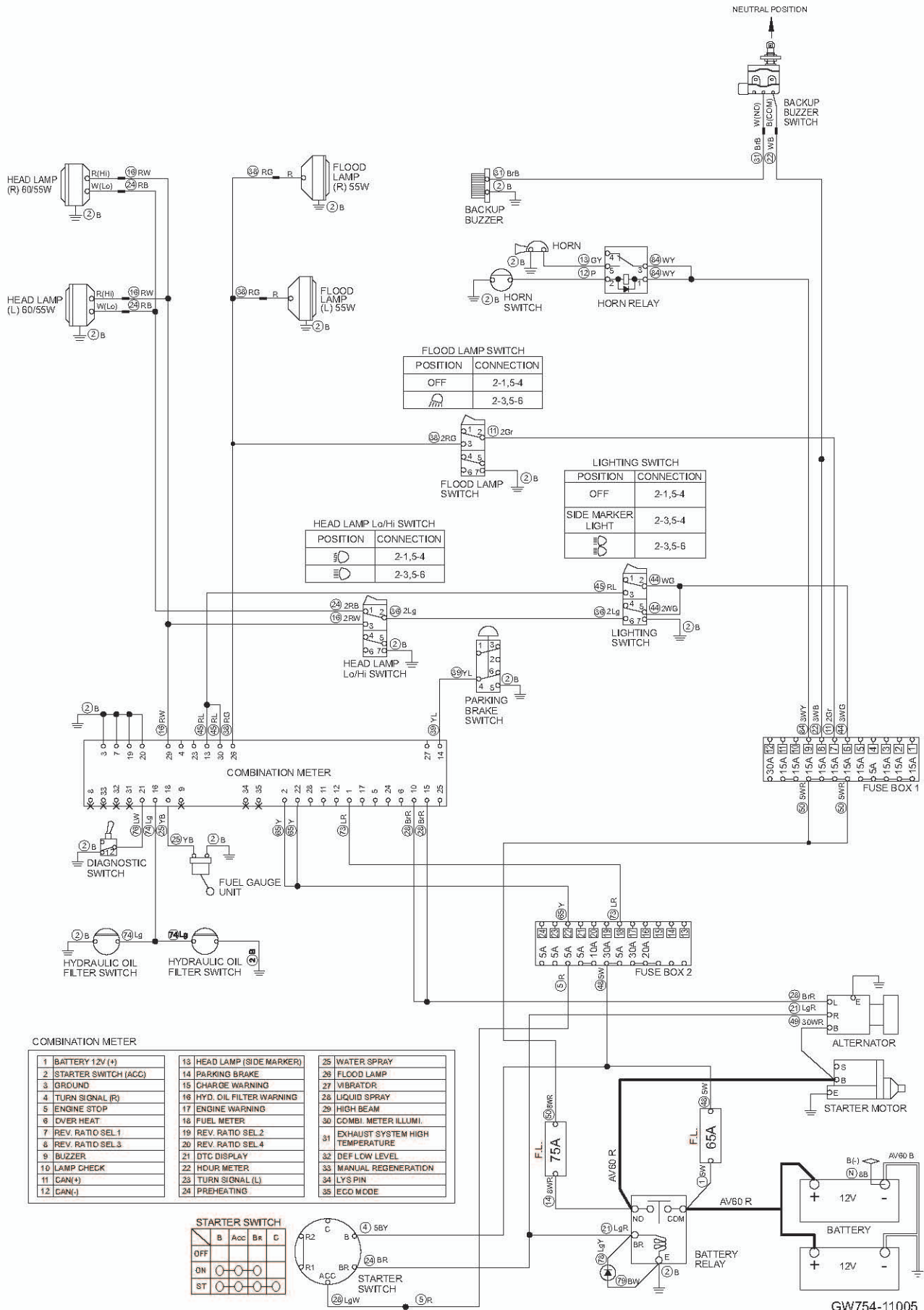

GW754-11005

2-7-14. Flood lamp indicator lamp does not light

- Check that flood lamp lights.

Reference Fig. : 2-7-1

Check point	Check/Cause	Action
1. Harness	<ul style="list-style-type: none"> • Measure resistance between flood lamp switch terminal 3 wire RG and combination meter connector terminal wire No.38 wire RG. Standard resistance : 10 Ω or less • If resistance is abnormal, harness is faulty. 	Repair or replace harness.
2. Combination Meter (Flood lamp indicator lamp)	<p>(1) When starter switch is ON, measure voltage between combination meter terminal wires and ground terminal wire.</p> <ul style="list-style-type: none"> • Battery 12 V (+) terminal wire No.73 inlet wire LR and ground terminal wire No.2 wire B • Starter switch (ACC) terminal wire No.65 inlet wire Y and ground terminal wire No.2 wire B <p>Standard voltage : 12 V or more</p> <p>(2) When starter switch is ON and flood lamp switch is "  ", measure voltage between combination meter flood lamp terminal wire No.38 inlet wire RG and chassis ground.</p> <p>Standard voltage : 12 V or more</p> <ul style="list-style-type: none"> • If above items (1) and (2) are OK and flood lamp indicator lamp does not light, combination meter is faulty. 	Replace combination meter.

2-7-15. Parking brake indicator lamp does not light

Reference Fig. : 2-7-1

Check point	Check/Cause	Action
1. Harness	<ul style="list-style-type: none"> • Measure resistance between parking brake switch terminal 4 wire YL and combination meter connector terminal wire No.39 wire YL. Standard resistance : 10 Ω or less • If resistance is abnormal, harness is faulty. 	Repair or replace harness.
2. Parking Brake Switch	<ul style="list-style-type: none"> • When parking brake switch is applied, check continuity between parking brake switch terminal 4 wire YL and terminal 5 wire B. There is continuity in normal condition. • If there is no continuity, parking brake switch is faulty. 	Replace parking brake switch.
3. Combination Meter (Parking brake indicator lamp)	<p>(1) When starter switch is ON, measure voltage between combination meter terminal wires and ground terminal wire.</p> <ul style="list-style-type: none"> • Battery 12 V (+) terminal wire No.73 inlet wire LR and ground terminal wire No.2 wire B • Starter switch (ACC) terminal wire No.65 inlet wire Y and ground terminal wire No.2 wire B <p>Standard voltage : 12 V or more</p> <p>(2) When parking brake switch is applied and starter switch is ON, check continuity between combination meter parking brake terminal wire No.39 inlet wire YL and chassis ground.</p> <p>There is continuity in normal condition.</p> <ul style="list-style-type: none"> • If above items (1) and (2) are OK and parking brake indicator lamp does not light, combination meter is faulty. 	Replace combination meter.

Fig.: 2-5-1

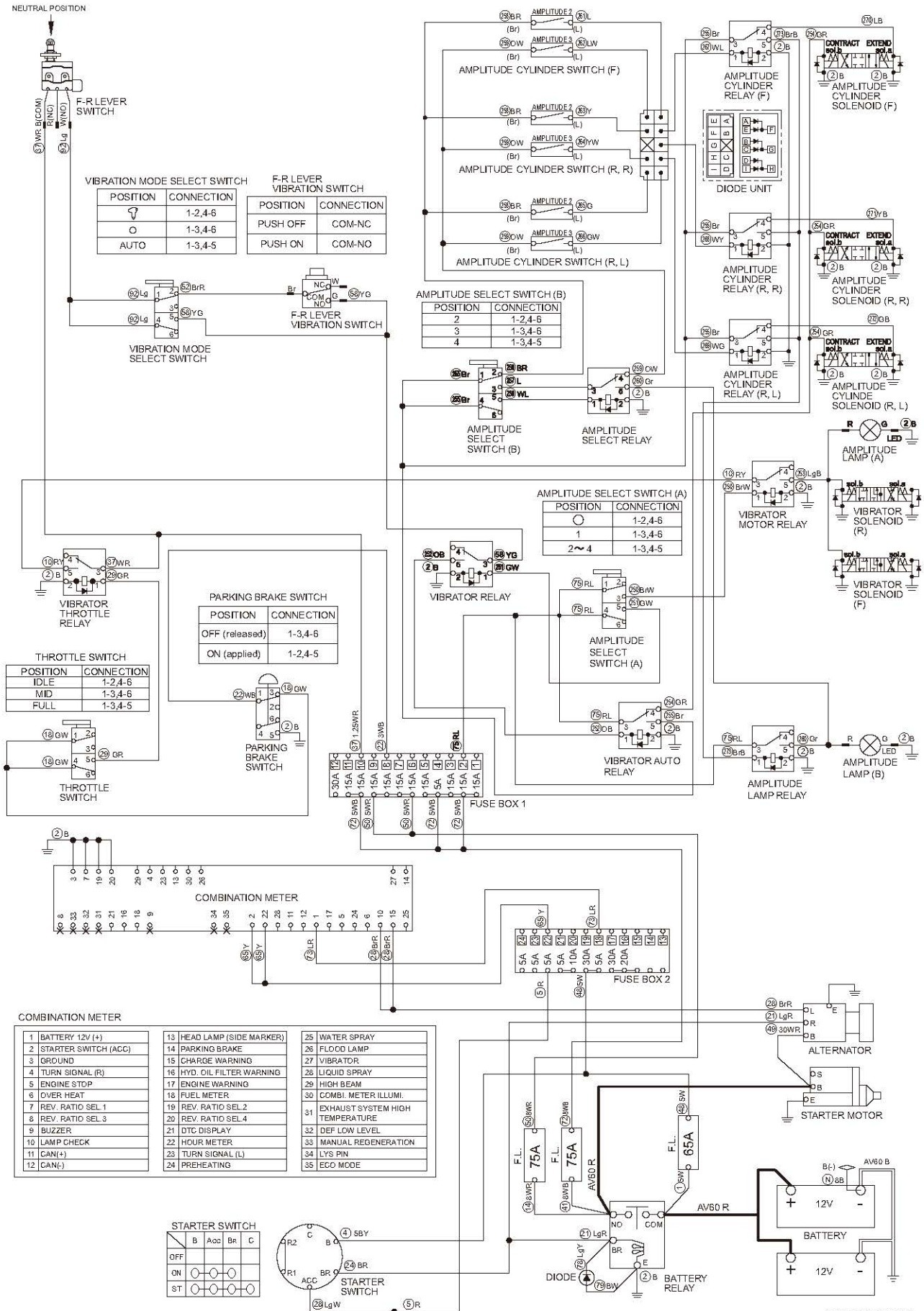

2-7-16. Amplitude lamp (A) does not light

- Parking brake switch must be released.
- Throttle switch must be "FULL".
- Amplitude select switch (A) must not be "O".

Reference Fig. : 2-5-1

Check point	Check/Cause	Action
1. Each Bulb	<ul style="list-style-type: none"> • Check that none of lamp bulbs is burned out or has a contact failure. • Bulb is faulty or poorly connected. 	Replace each bulb.
2. Vibrator Motor Relay	<p>(1) When starter switch is ON, measure voltage between vibrator motor relay terminal 1 inlet wire BrW and chassis ground. Standard voltage : 12 V or more</p> <p>(2) When starter switch is ON, measure voltage between vibrator motor relay terminal 3 inlet wire RY and chassis ground. Standard voltage : 12 V or more</p> <p>(3) When starter switch is ON, measure voltage between vibrator motor relay terminal 5 outlet wire LgB and chassis ground. Standard voltage : 12 V or more</p> <ul style="list-style-type: none"> • If above items (1) and (2) are OK and item (3) is NG, vibrator motor relay is faulty. 	Replace vibrator motor relay.
3. Vibrator Throttle Relay	<p>(1) When starter switch is ON, measure voltage between vibrator throttle relay terminal 1 inlet wire GR and chassis ground. Standard voltage : 12 V or more</p> <p>(2) When starter switch is ON, measure voltage between vibrator throttle relay terminal 3 inlet wire WR and chassis ground. Standard voltage : 12 V or more</p> <p>(3) When starter switch is ON, measure voltage between vibrator throttle relay terminal 5 outlet wire RY and chassis ground. Standard voltage : 12 V or more</p> <ul style="list-style-type: none"> • If above items (1) and (2) are OK and item (3) is NG, vibrator throttle relay is faulty. 	Replace vibrator throttle relay.
4. Harness Connecting Between Terminals	<ul style="list-style-type: none"> • Measure resistance of harness connecting between terminals. Standard resistance : 10 Ω or less • If resistance is abnormal, harness is faulty. 	Repair or replace harness.

Fig.: 2-5-1

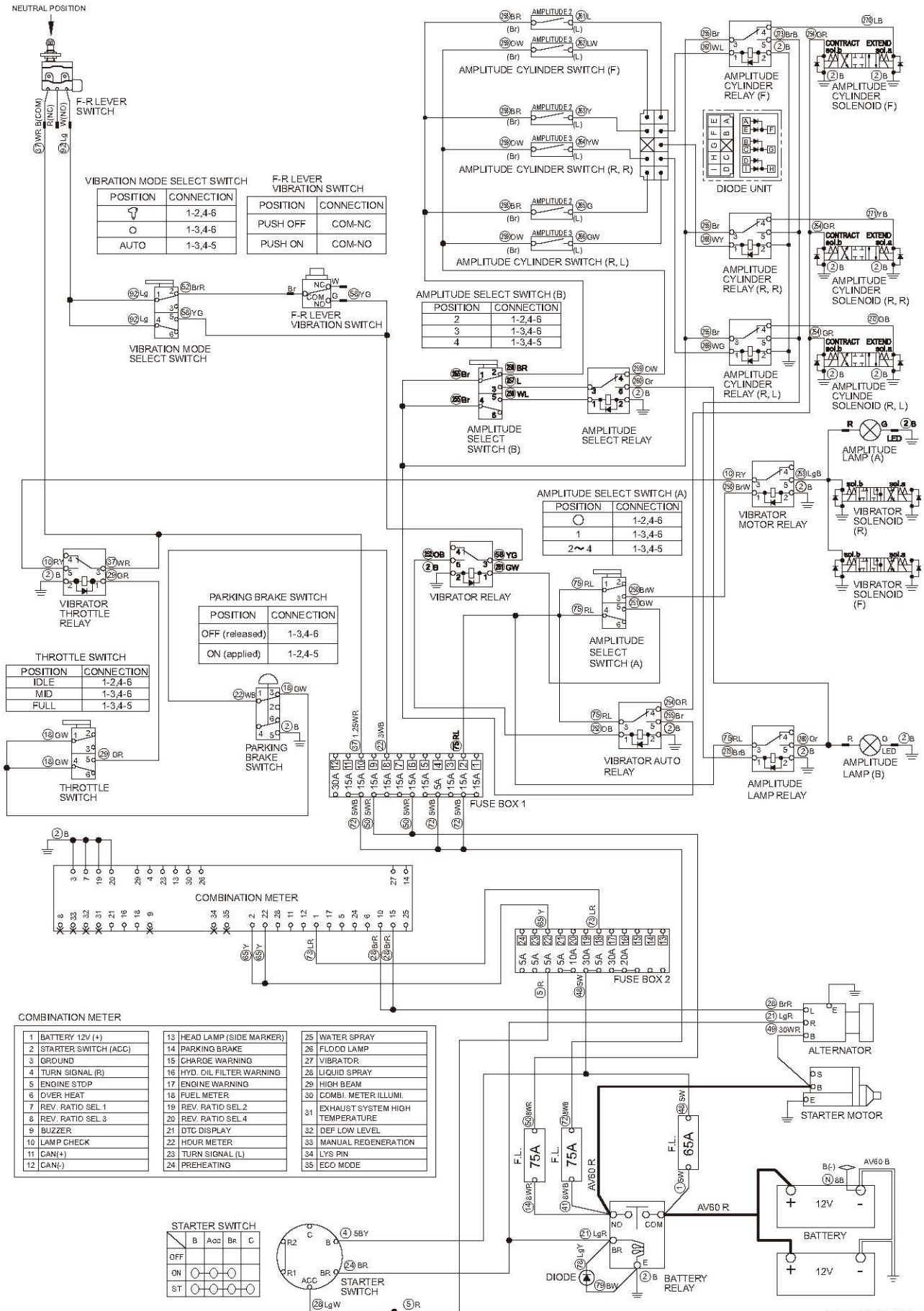

COMBINATION METER

1 BATTERY 12V (+)	13 HEAD LAMP (SIDE MARKER)	25 WATER SPRAY
2 STARTER SWITCH (ACC)	14 PARKING BRAKE	26 FLOOD LAMP
3 GROUND	15 CHARGE WARNING	27 VIBRATOR
4 TURN SIGNAL (R)	16 HYD. OIL FILTER WARNING	28 LIQUID SPRAY
5 ENGINE STOP	17 ENGINE WARNING	29 HIGH BEAM
6 OVER HEAT	18 FUEL METER	30 COMBI. METER ILLUMI.
7 REV. RATIO SEL 1	19 REV. RATIO SEL 2	31 EXHAUST SYSTEM HIGH TEMPERATURE
8 REV. RATIO SEL 3	20 REV. RATIO SEL 4	32 DEF LOW LEVEL
9 BUZZER	21 DTC DISPLAY	33 MANUAL REGENERATION
10 LAMP CHECK	22 HOUR METER	34 LYS PIN
11 CAN (+)	23 TURN SIGNAL (L)	35 ECO MODE
12 CAN (-)	24 PREHEATING	

STARTER SWITCH

OFF	B	Acc	Br	C
ON	○	○	○	○
ST	○	○	○	○

2-7-17. Amplitude lamp (B) does not light

- Amplitude select switch (A) must be "2 ~ 4".
- F-R lever must be "F" or "R".
- Vibration mode select switch must be "AUTO".

Reference Fig. : 2-5-1

Check point	Check/Cause	Action
1. Each Bulb	<ul style="list-style-type: none"> • Check that none of lamp bulbs is burned out or has a contact failure. • Bulb is faulty or poorly connected. 	Replace each bulb.
2. Amplitude Lamp Relay	<p>(1) When starter switch is ON and amplitude select switch (B) is "2" or "3", measure voltage between amplitude lamp relay terminal 1 inlet wire BrB and chassis ground. Standard voltage : 12 V or more</p> <p>(2) When starter switch is ON, measure voltage between amplitude lamp relay terminal 3 inlet wire RL and chassis ground. Standard voltage : 12 V or more</p> <p>(3) When starter switch is ON and amplitude select switch (B) is "2" or "3", measure voltage between amplitude lamp relay terminal 5 outlet wire Gr and chassis ground. Standard voltage : 12 V or more</p> <ul style="list-style-type: none"> • If above items (1) and (2) are OK and item (3) is NG, amplitude lamp relay is faulty. 	Replace amplitude lamp relay.
3. Amplitude Select Relay	<p>(1) When starter switch is ON and amplitude select switch (B) is "4", measure voltage between amplitude select relay terminal 1 inlet wire WL and chassis ground. Standard voltage : 12 V or more</p> <p>(2) When starter switch is ON and amplitude select switch (B) is "4", measure voltage between amplitude select relay terminal 3 inlet wire L and chassis ground. Standard voltage : 12 V or more</p> <p>(3) When starter switch is ON and amplitude select switch (B) is "4", measure voltage between amplitude select relay terminal 5 outlet wire Gr and chassis ground. Standard voltage : 12 V or more</p> <ul style="list-style-type: none"> • If above items (1) and (2) are OK and item (3) is NG, amplitude select relay is faulty. 	Replace amplitude select relay.
4. Harness Connecting Between Terminals	<ul style="list-style-type: none"> • Measure resistance of harness connecting between terminals. Standard resistance : 10 Ω or less • If resistance is abnormal, harness is faulty. 	Repair or replace harness.

Fig.: 2-7-1

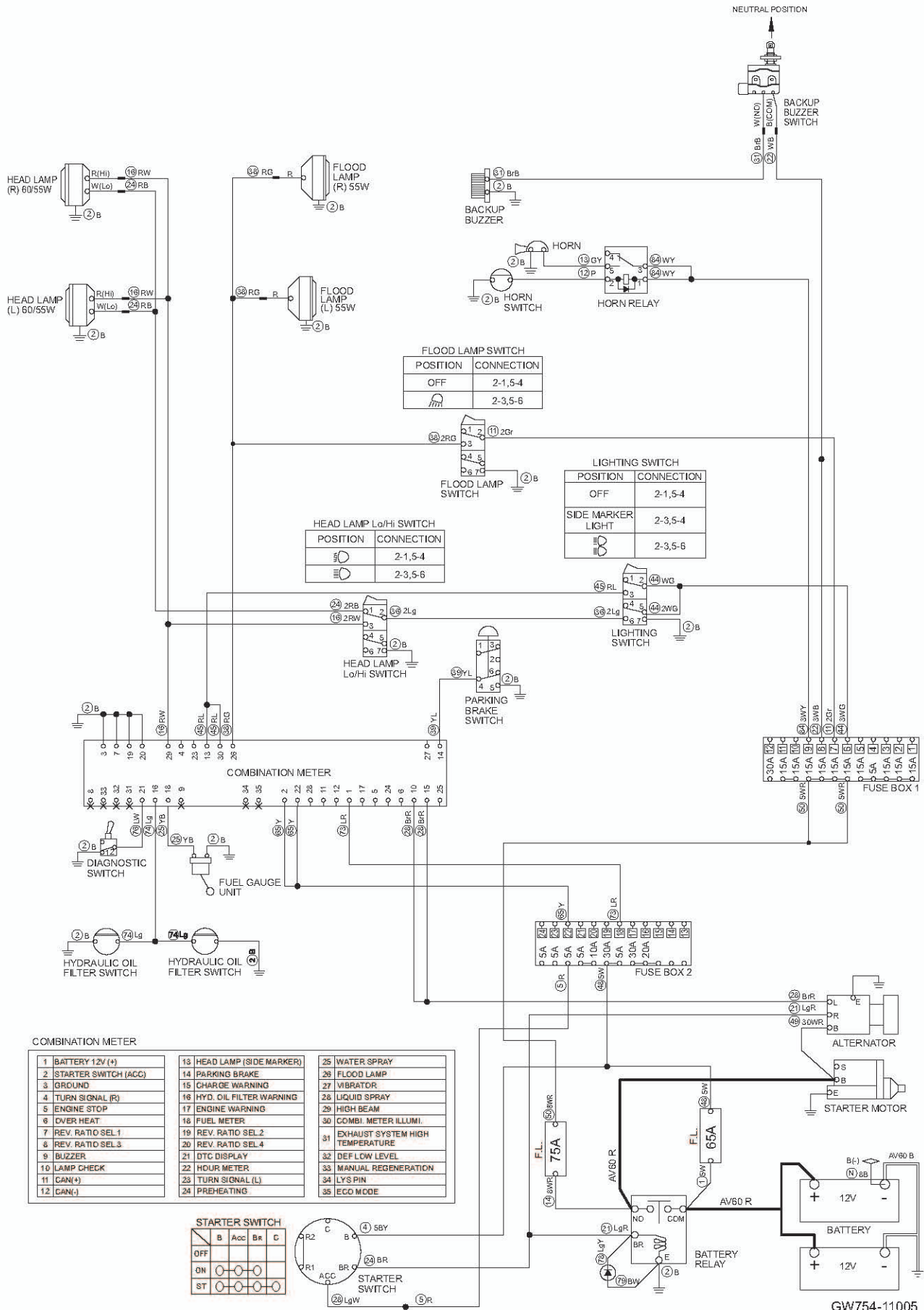

GW754-11005

2-7-18. Horn does not sound

Reference Fig. : 2-7-1

Check point	Check/Cause	Action
1. Horn	<ul style="list-style-type: none"> • Disconnect horn and directly connect battery positive terminal to horn terminal wire GY side and negative terminal to horn terminal wire B side. • If horn does not sound, horn is faulty. 	Replace horn.
2. Horn Relay	<p>(1) When starter switch is ON, measure voltage between horn relay terminal 1 and 3 inlet wire WY and chassis ground. Standard voltage : 12 V or more</p> <p>(2) When starter switch is ON and horn switch pressed, measure voltage between horn relay terminal 5 outlet wire GY and chassis ground. Standard voltage : 12 V or more</p> <ul style="list-style-type: none"> • If above item (1) is OK and item (2) is NG, horn relay is faulty. 	Replace horn relay.
3. Horn Switch	<ul style="list-style-type: none"> • When horn switch is pressed, check continuity between horn switch terminals. There is continuity in normal condition. • If there is no continuity, horn switch is faulty. 	Replace horn switch.
4. Harness Connecting Between Terminals	<ul style="list-style-type: none"> • Measure resistance of harness connecting between terminals. Standard resistance : 10 Ω or less • If resistance is abnormal, harness is faulty. 	Repair or replace harness.

2-7-19. Backup buzzer does not sound

Reference Fig. : 2-7-1

Check point	Check/Cause	Action
1. Backup Buzzer	<ul style="list-style-type: none"> • Disconnect backup buzzer and directly connect battery positive terminal to backup buzzer terminal wire BrB side and negative terminal to backup buzzer terminal wire B side. • If backup buzzer does not sound, backup buzzer is faulty. 	Replace backup buzzer.
2. Backup Buzzer Switch	<p>(1) When starter switch is ON, measure voltage between backup buzzer switch terminal inlet wire WB and chassis ground. Standard voltage : 12 V or more</p> <p>(2) When starter switch is ON and F-R lever is "R" , measure voltage between backup buzzer switch terminal outlet wire BrB and chassis ground. Standard voltage : 12 V or more</p> <ul style="list-style-type: none"> • If above item (1) is OK and item (2) is NG, backup buzzer switch is faulty. 	Replace backup buzzer switch.
3. Harness Connecting Between Terminals	<ul style="list-style-type: none"> • Measure resistance of harness connecting between terminals. Standard resistance : 10 Ω or less • If resistance is abnormal, harness is faulty. 	Repair or replace harness.

3. HYDRAULIC SYSTEM TROUBLESHOOTING

3-1. When Performing Hydraulic System Troubleshooting

- The largest factor in the majority of failures of hydraulic devices operating under conditions of higher pressure and greater precision is the entry of dirt (foreign substances) into the hydraulic circuit. Particular caution is required when supplying hydraulic oil or when disassembling and assembling hydraulic devices.

1) Pay attention to the work environment.

As much as possible, avoid performing tasks such as supplying hydraulic oil, replacing filters and repair work on rainy days, when there is strong wind, or in locations where there is much dust.

2) Disassembly and maintenance work in the field

There is the danger of dust entry when disassembly and maintenance work for hydraulic components is performed in the field. In addition, because performance verification after repairs are completed is difficult, replacement of the entire assembly is preferred. Perform disassembly and maintenance of hydraulic components in a special room protected from dust, and use special testers to verify the performance.

3) Sealing of openings

Use caps, tape, plastic bags or other means to seal the openings of removed pipes and components in order to prevent foreign substances from entering. Never leave the openings exposed or put a shop cloth into them. There is the danger of foreign substances entering or of leaking oil causing environmental contamination. Do not dispose of waste oil on-site. Either deliver it to the customer and request disposal or take it back with you and dispose of it.

4) Prevent entry of foreign substances when supplying oil.

Take care that foreign substances do not enter when supplying hydraulic oil. Clean the oil supply port and the area around it, as well as the supply pump, oilcan and other items. A more reliable method is to use oil cleaning equipment, which can filter out the contamination that occurred during storage.

5) Change hydraulic oil while the temperature is still high.

All oils, including hydraulic oil, flow more readily when they are warm. Higher temperatures also make it easier to eject the sludge and other substances outside the circuit together with the oil. For these reasons, oil changes should be performed while the oil temperature is high. When changing the oil, it is necessary to drain out as much of the old hydraulic oil as possible. (In addition to the hydraulic oil tank, also drain the oil from the filter and circuit drain plugs.) If old hydraulic oil remains in the system, the contaminants and sludge in the old oil will mix with the new oil and shorten the hydraulic oil lifetime.

3-2. Propulsion System

If a problem occurs in the propulsion systems such as the propulsion pump, propulsion motor and brakes, determine the cause and carry out action as required, according to the following general troubleshooting items.

(NOTICE)

- When checking whether or not the pressure is correct, refer to the pressure standard value for each hydraulic circuit.

3-2-1. Machine moves neither forward nor backward 1/2

Check point	Cause	Check/Action
1. Oil Level of Hydraulic Oil Tank	Oil level in hydraulic oil tank is low.	Fill tank until correct oil level is obtained.
2. Bypass Valve	Bypass valve is open.	Close bypass valve.
3. F-R Lever Linkage	F-R lever linkage is faulty.	Check and adjust F-R lever linkage or replace it if necessary.
4. Charge Circuit Pressure	Propulsion pump does not discharge oil because charge pressure is low.	<ul style="list-style-type: none"> • Measure charge pressure. • If low, check and adjust charge pressure relief valve or replace it if necessary.
	Insufficient steering • charge pump discharge.	Repair steering • charge pump or replace it if necessary.
	Charge pressure decreases due to internal leakage of solenoid valve connecting oil supply circuit with charge circuit. <ul style="list-style-type: none"> • Amplitude cylinder solenoid valve (F) • Amplitude cylinder solenoid valve (R,L) • Amplitude cylinder solenoid valve (R,R) • Parking brake solenoid valve 	<ul style="list-style-type: none"> • When solenoid is energized, check if oil flows in return circuit to tank. • If oil is flowing, repair solenoid valve or replace it if necessary.
5. Servo Bypass Solenoid Valve	Propulsion pump does not discharge oil because spool of servo bypass solenoid valve is stuck.	Repair servo bypass solenoid valve or replace it if necessary.
6. Suction Filter for Steering • charge Pump	Steering • charge pump flow is reduced due to clogged filter.	Clean suction filter 2 or replace it if necessary.
7. Propulsion Circuit Pressure	Circuit does not obtain required pressure because setting pressure of high pressure relief is low.	<ul style="list-style-type: none"> • Measure propulsion circuit pressure. • If low, check and clean high pressure relief valve or replace it if necessary.
8. Propulsion Servo Circuit Pressure	Circuit does not obtain required pressure because setting pressure of pressure limiter is low.	<ul style="list-style-type: none"> • Measure propulsion servo circuit pressure. • If low, check and adjust pressure limiter valve or replace it if necessary.
9. Propulsion Motor	Internal leakage of propulsion motor.	<ul style="list-style-type: none"> • Measure drain quantity from propulsion motor. • If drain quantity is larger than standard value, repair propulsion motor or replace it if necessary.
	Sticking of disc brakes.	Repair propulsion motor or replace it if necessary.

3-2-1. Machine moves neither forward nor backward 2/2

Check point	Cause	Check/Action
10. Parking Brake Solenoid Valve	Brake remains applied because spool of parking brake solenoid valve does not shift.	Repair parking brake solenoid valve or replace it if necessary.
11. Brake Inlet Pressure	Brake cannot be released because brake inlet pressure is low.	<ul style="list-style-type: none"> • Measure brake release pressure. • If low, repair or replace propulsion motor.
12. Brake Valve	Brake cannot be released because brake valve circuit is closed.	Repair brake valve or replace it if necessary.
13. Coupling	Drive torque is not transmitted to pump due to a faulty coupling.	Replace coupling.

3-2-2. Machine moves in one direction only (forward or backward)

Check point	Cause	Check/Action
1. F-R Lever Linkage	F-R lever linkage is faulty.	Check and adjust F-R lever linkage or replace it if necessary.
2. High Pressure Relief Valve	Low circuit pressure due to incorrect high pressure relief setting or internal leakage of high pressure relief valve.	<ul style="list-style-type: none"> • Interchange two high pressure relief valves. • If faulty condition is accordingly reversed, check and clean high pressure relief valve or replace it if necessary.
3. Pressure Limiter Valve	Low circuit pressure due to incorrect pressure limiter setting or internal leakage of pressure limiter valve.	<ul style="list-style-type: none"> • Interchange two pressure limiter valves. • If faulty condition is accordingly reversed, check and adjust pressure limiter valve or replace it if necessary.

3-2-3. Slow machine speed or small drive force

Check point	Cause	Check/Action
1. Bypass Valve	Bypass valve is slightly open.	Close bypass valve completely.
2. F-R Lever Linkage	F-R lever linkage is faulty.	Check and adjust F-R lever linkage or replace it if necessary.
3. Charge Circuit Pressure	Stroke of propulsion pump swash plate is small because charge pressure is low, decreasing discharge rate of propulsion pump.	<ul style="list-style-type: none"> • Measure charge pressure. • If low, check and adjust charge pressure relief valve or replace it if necessary.
	Insufficient steering • charge pump discharge.	Repair steering • charge pump or replace it if necessary.
	Charge pressure decreases due to internal leakage of solenoid valve connecting oil supply circuit with charge circuit. <ul style="list-style-type: none"> • Amplitude cylinder solenoid valve (F) • Amplitude cylinder solenoid valve (R,L) • Amplitude cylinder solenoid valve (R,R) • Parking brake solenoid valve 	<ul style="list-style-type: none"> • When solenoid is energized, check if oil flows in return circuit to tank. • If oil is flowing, repair solenoid valve or replace it if necessary.
4. Suction Filter for Steering • Charge Pump	Flow rate of steering • charge pump decreases as well as charge pressure decreases due to clogged filter.	Clean suction filter 2 or replace it if necessary.
5. Propulsion Motor	Propulsion motor inlet pressure is low.	<ul style="list-style-type: none"> • Measure propulsion motor inlet pressure. • If low, check and clean high pressure relief valve or replace it if necessary.
	Propulsion circuit pressure is not held in propulsion motor case.	If pressure in propulsion motor case is not within allowable range, repair propulsion motor or replace it if necessary.
	Output of propulsion motor decreases and number of revolutions decreases due to internal leakage of propulsion motor.	<ul style="list-style-type: none"> • Measure drain quantity from propulsion motor. • If drain quantity is larger than standard value, repair propulsion motor or replace it if necessary.
6. Propulsion Pump	Discharge flow rate is insufficient due to efficiency degradation of propulsion pump.	<ul style="list-style-type: none"> • Measure discharge flow rate of propulsion pump with flow meter. • If discharge flow rate is not within specified range, repair propulsion pump or replace it if necessary.
	Discharge flow rate is insufficient due to wear of propulsion pump drive shaft splines.	Replace propulsion pump.
	Propulsion circuit pressure is not held in propulsion pump case.	If pressure in propulsion pump case is not within allowable range, repair propulsion pump or replace it if necessary.

3-2-4. Machine does not stop completely with F-R lever in “N”.

Check point	Cause	Check/Action
1. F-R lever Linkage	F-R lever linkage is faulty.	Check and adjust F-R lever linkage or replace it if necessary.
2. Servo Control Valve	Servo control valve neutral position adjustment failure.	Check and clean servo control valve or replace it if necessary.
3. Propulsion Pump Servo Cylinder	Faulty propulsion pump servo cylinder or faulty pump swash plate setting.	Repair propulsion pump or replace it if necessary.

3-2-5. Propulsion system is overheating

Check point	Cause	Check/Action
1. Oil Level of Hydraulic Oil Tank	Oil level in hydraulic oil tank is low.	Fill tank until correct oil level is obtained.
2. Oil Cooler	Cooling efficiency is reduced due to clogged oil cooler fins.	Clean oil cooler fins.
3. Flushing Valve	Hydraulic oil in propulsion closed circuit is insufficiently cooled due to flushing valve shuttle spool sticking.	Repair flushing valve or replace it if necessary.
	Hydraulic oil in propulsion closed circuit is insufficiently cooled because flushing valve relief setting pressure is excessively high.	Clean flushing relief valve or replace it if necessary.
4. Propulsion Circuit Pressure	If circuit pressure setting is excessively low, relief valve opens, causing temperature of hydraulic oil in circuit to rise.	<ul style="list-style-type: none"> • Measure propulsion circuit pressure. • If low, increase relief setting pressure.
	If load is excessively heavy, relief valve opens, causing temperature of hydraulic oil in circuit to rise.	<ul style="list-style-type: none"> • Measure propulsion circuit pressure. • If high, decrease propulsion load.
5. Suction Filter for Steering • Charge Pump	Load of steering • charge pump increases due to clogged filter, causing temperature of hydraulic oil in circuit to rise.	Clean suction filter 2 or replace it if necessary.
6. Hydraulic Oil Filter 2	Charge circuit pressure increases due to clogged filter.	Clean hydraulic oil filter 2 or replace it if necessary.

3-2-6. Abnormal noise from propulsion system

Check point	Cause	Check/Action
1. Roller Bearings	Roller bearings supporting front and rear tires are damaged.	Replace roller bearings.
2. Hydraulic Hose Clamp	Vibrator sound of hydraulic hose is generated because clamp securing hydraulic hose is loose.	Tighten bolts of loose hydraulic hose clamp to specified torque.
3. Suction Filter for Steering • Charge Pump	Cavitation is occurring in steering • charge pump due to clogged filter.	Clean suction filter 2 or replace it if necessary.
4. Charge Circuit Pressure	If charge pressure is low, brake cannot be released completely, which causes brake drag.	<ul style="list-style-type: none"> • Measure charge pressure. • If low, check and adjust charge pressure relief valve or replace it if necessary.
5. Propulsion Motor	Internal bearing of propulsion motor is damaged.	Repair propulsion motor or replace it if necessary.

3-3. Vibrator System

If a problem occurs in the vibrator systems such as the vibrator pump, vibrator motor and vibrator solenoid valve, determine the cause and carry out action as required, according to the following general troubleshooting items.

(NOTICE)

- When checking whether or not the pressure is correct, refer to the pressure standard value for each hydraulic circuit.

3-3-1. No vibration

Check point	Cause	Check/Action
1. Engine RPM	Vibration will not occur unless engine rotation is 1,900 rpm or higher.	If engine rotation speed is low, adjust engine speed to 1,900 rpm or higher.
2. Oil Level of Hydraulic Oil Tank	Oil level in hydraulic oil tank is low.	Fill tank until correct oil level is obtained.
3. Vibrator Circuit Pressure	Circuit does not obtain required pressure because setting pressure of relief valve is low.	<ul style="list-style-type: none"> • Measure vibrator circuit pressure. • If low, check and adjust relief valve or replace them if necessary.
4. Vibrator Solenoid Valve	Vibrator motor cannot discharge oil because spool of vibrator solenoid valve does not shift.	Repair vibrator solenoid valve or replace it if necessary.
	Circuit pressure decrease due to relief valve setting failure or internal leakage.	<ul style="list-style-type: none"> • Measure vibrator circuit pressure. • If low, check and adjust relief valve or replace them if necessary.
5. Suction Filter for Vibrator Pump	Vibrator pump flow is reduced due to clogged filler.	Clean suction filter 1 or replace it if necessary.
6. Vibrator Pump	Insufficient discharge rate from vibrator pump due to reduced efficiency of vibrator pump.	<ul style="list-style-type: none"> • Measure discharge flow rate of vibrator pump with flow meter. • If discharge flow rate is not within specified range, repair vibrator pump or replace it if necessary.
	Insufficient pump discharge due to wear of vibrator pump drive shaft spline.	Replace vibrator pump.
7. Vibrator Motor	Internal leakage of vibrator motor.	<ul style="list-style-type: none"> • Measure drain quantity from vibrator motor. • If drain quantity is larger than standard value, repair vibrator motor or replace it if necessary.
	Output torque is not transmitted due to worn spline of vibrator motor output shaft.	Replace vibrator motor.

3-3-2. Vibrator frequency is too low

Check point	Cause	Check/Action
1. Oil Level of Hydraulic Oil Tank	Oil level in hydraulic oil tank is low.	Fill tank until correct oil level is obtained.
2. Suction Filter for Vibrator Pump	Vibrator pump flow is reduced due to clogged filter.	Clean suction filter 1 or replace it if necessary.
3. Vibrator Circuit Pressure	Circuit pressure decrease due to relief valve setting failure or internal leakage.	<ul style="list-style-type: none"> • Vibrator circuit of front and rear relief valves are exchanged. • If phenomenon reverses, check and adjust relief valves or replace it if necessary.
4. Vibrator Motor	Vibrator motor inlet pressure is low.	<ul style="list-style-type: none"> • Measure vibrator motor inlet pressure. • If low, check and adjust relief valve or replace it if necessary.
	Decrease in vibrator motor rpm due to internal leakage in vibrator motor.	<ul style="list-style-type: none"> • Measure drain quantity from vibrator motor. • If drain quantity is larger than standard value, repair vibrator motor or replace it if necessary.
5. Vibrator Pump	Insufficient discharge rate from vibrator pump due to reduced efficiency of vibrator pump.	<ul style="list-style-type: none"> • Measure discharge flow rate of vibrator pump with flow meter. • If discharge flow rate is not within specified range, repair vibrator pump or replace it if necessary.
	Insufficient pump discharge due to wear of vibrator pump drive shaft spline.	Replace vibrator pump.
	Vibrator circuit pressure is not held in vibrator pump case.	If pressure in vibrator pump case is not within allowable range, repair vibrator pump or replace it if necessary.

3-3-3. Amplitude cannot be switched between high and low

Check point	Cause	Check/Action
1. Oil Level of Hydraulic Oil Tank	Cylinder does not actuate because oil level of hydraulic oil tank is low, amplitude cylinder circuit pressure is reduced.	Fill tank until correct oil level is obtained.
2. Amplitude Cylinder	Amplitude cylinder inlet pressure is low.	<ul style="list-style-type: none"> • Measure amplitude cylinder inlet pressure. • If low, check and adjust charge pressure relief valve or replace it if necessary.
	Cylinder abnormality due to internal leakage in amplitude cylinder.	If cylinder can be moved by hand while choking up inlet/outlet ports, repair or replace cylinder.
3. Amplitude Cylinder Solenoid Valve	Amplitude cylinder does not discharge oil because spool of amplitude cylinder solenoid valve does not shift.	Repair amplitude cylinder solenoid valve or replace it if necessary.
4. Suction Filter for Steering • Charge Pump	Decrease in steering • charge pump discharge rate and decrease in amplitude switching circuit pressure due to clogged filter.	Clean suction filter 2 or replace it if necessary.

3-3-4. Vibrator does not stop

Check point	Cause	Check/Action
1. Engine RPM	Vibration does not stop unless engine rotation speed is 1,900 rpm or lower.	If engine speed is high, lower engine speed.
2. Vibrator Solenoid Valve	Vibrator solenoid valve spool does not return to neutral position.	Repair vibrator solenoid valve or replace it if necessary.

3-3-5. Vibrator system is overheating

Check point	Cause	Check/Action
1. Oil Level of Hydraulic Oil Tank	Oil level in hydraulic oil tank is low.	Fill tank until correct oil level is obtained.
2. Oil Cooler	Cooling efficiency is reduced due to clogged oil cooler fins.	Clean oil cooler fins.
3. Vibrator Circuit Pressure	If circuit pressure setting is excessively low, relief valve opens, causing temperature of hydraulic oil in circuit to rise.	<ul style="list-style-type: none"> • Measure vibrator circuit pressure. • If low, increase relief setting pressure.
	If load is excessively heavy, relief valve opens, causing temperature of hydraulic oil in circuit to rise.	<ul style="list-style-type: none"> • Measure vibrator circuit pressure. • If high, decrease vibration load.
4. Suction Filter for Vibrator Pump	Load of vibrator pump increases due to clogged filter, causing temperature of hydraulic oil in circuit to rise.	Clean suction filter 1 or replace it if necessary.

3-3-6. Abnormal noise from vibrator system

Check point	Cause	Check/Action
1. Vibrator Bearings	Vibrator bearings supporting eccentric shaft are damaged.	Replace vibrator bearings.
2. Hydraulic Hose Clamp	Vibrator sound of hydraulic hose is generated because clamp securing hydraulic hose is loose.	Tighten bolts of loose hydraulic hose clamp to specified torque.
3. Suction Filter for Vibrator Pump	Cavitation is occurring in vibrator pump due to clogged filter.	Clean suction filter 1 or replace it if necessary.
4. Vibrator Motor	Internal bearing of vibrator motor is damaged.	Repair vibrator motor or replace it if necessary.

3-4. Steering System

If a problem occurs in the steering systems such as the steering • charge pump and orbitrol, determine the cause and carry out action as required, according to the following general troubleshooting items.

(NOTICE)

- When checking whether or not the pressure is correct, refer to the pressure standard value for each hydraulic circuit.

3-4-1. Steering wheel is hard to turn

Check point	Cause	Check/Action
1. Oil Level of Hydraulic Oil Tank	Oil level in hydraulic oil tank is low.	Fill tank until correct oil level is obtained.
2. Orbitrol	Relief valve is open or setting pressure is low.	<ul style="list-style-type: none"> • Measure steering circuit pressure. • If low, clean relief valve or replace it if necessary.
	Flow to steering cylinder circuit is insufficient due to leakage from check valve.	Check and clean check valve or replace it if necessary.
	Spool and sleeve of orbitrol are contaminated or clearance is incorrect.	Check and clean orbitrol or replace it if necessary.
3. Steering Circuit Pressure	Pressure in return circuit from orbitrol increases due to clogged charging hydraulic filter 2.	Clean hydraulic oil filter 2 or replace it if necessary.
4. Steering Cylinder	Cylinder thrust decreases due to internal leakage of steering cylinder.	Repair steering cylinder or replace it if necessary.
5. Suction Filter for Steering • Charge Pump	Steering • charge pump discharge rate decreases due to clogged filter.	Clean suction filter 2 or replace it if necessary.
6. Steering • Charge Pump	Discharging pressure is insufficient due to efficiency degradation of steering • charge pump.	<ul style="list-style-type: none"> • Measure steering circuit pressure. • If low, replace steering • charge pump.
7. Steering Column	Column shaft and orbitrol shaft center are misaligned.	Align column shaft with orbitrol shaft center or replace it if necessary.
	Column shaft bearing is worn or damaged.	Repair column shaft or replace it if necessary.

3-4-2. Steering response is slow

Check point	Cause	Check/Action
1. Oil Level of Hydraulic Oil Tank	Oil level in hydraulic oil tank is low.	Fill tank until correct oil level is obtained.
2. Orbitrol	Oil is bypassing because relief valve is open.	<ul style="list-style-type: none"> • Measure steering circuit pressure. • If low, clean relief valve or replace it if necessary.
3. Steering Cylinder	Internal leakage of steering cylinder.	Repair steering cylinder or replace it if necessary.
4. Suction Filter for Steering • Charge Pump	Steering • charge pump discharge rate decreases due to clogged filter.	Clean suction filter 2 or replace it if necessary.
5. Steering • Charge Pump	Discharging pressure is insufficient due to efficiency degradation of steering • charge pump.	<ul style="list-style-type: none"> • Measure steering circuit pressure. • If low, replace steering • charge pump.

3-4-3. Steering wheel backlash or play is large

Check point	Cause	Check/Action
1. Steering Column	Spline of column shaft or orbitrol is worn.	Replace column shaft or orbitrol.
	Column shaft bearings are worn.	Replace column shaft bearings.
2. Steering Wheel	Serration (spline) of wheel or column shaft is worn.	Replace wheel or column shaft.

3-4-4. Steering system is overheating

Check point	Cause	Check/Action
1. Oil Level of Hydraulic Oil Tank	Oil level in hydraulic oil tank is low.	Fill tank until correct oil level is obtained.
2. Oil Cooler	Cooling efficiency is reduced due to clogged oil cooler fins.	Clean oil cooler fins.
3. Steering Circuit Pressure	If circuit pressure setting is excessively low, relief valve is open, causing temperature of hydraulic oil in circuit to rise.	<ul style="list-style-type: none"> • Measure steering circuit pressure. • If low, replace relief valve.
	If load is excessively heavy, relief valve is open, causing temperature of hydraulic oil in circuit to rise.	<ul style="list-style-type: none"> • Measure steering circuit pressure. • If high, decrease steering load.
4. Suction Filter for Steering • Charge Pump	Load of steering • charge pump increases due to clogged filter, causing temperature of hydraulic oil in circuit to rise.	Clean suction filter 2 or replace it if necessary.

3-4-5. Abnormal noise from steering system

Check point	Cause	Check/Action
1. Oil Level of Hydraulic Oil Tank	Pump suction pressure is high because oil level of hydraulic oil tank is low, causing cavitation in steering circuit system.	Fill tank until correct oil level is obtained.
2. Air in Steering Circuit	Cavitation is caused by air in circuit.	Bleed circuit.
3. Hydraulic Hose Clamp	Vibrator sound of hydraulic hose is generated because clamp securing hydraulic hose is loose.	Tighten bolts of loose hydraulic hose clamp to specified torque.
4. Suction Filter for Steering • Charge Pump	Cavitation is occurring in steering • charge pump due to clogged filter.	Clean suction filter 2 or replace it if necessary.

3-5. Brake System

If a problem occurs in the brake systems such as the brake and parking brake solenoid valve, determine the cause and carry out action as required, according to the following general troubleshooting items.

(NOTICE)

- When checking whether or not the pressure is correct, refer to the pressure standard value for each hydraulic circuit.

3-5-1. Parking brake does not operate

Check point	Cause	Check/Action
1. Parking Brake Solenoid Valve	Brake does not operate because the spool of parking brake solenoid valve does not switch over.	<ul style="list-style-type: none"> • Measure brake circuit pressure. • If the pressure of releasing circuit is high, repair parking brake solenoid valve or replace it if necessary.
2. Propulsion Motor	Brake does not operate because disk brake is worn.	<ul style="list-style-type: none"> • Measure brake circuit pressure. • If the pressure of releasing circuit is low, repair propulsion motor or replace it if necessary.

3-5-2. Brake cannot be released

Check point	Cause	Check/Action
1. Parking Brake Solenoid Valve	Brake does not release due to locking parking brake solenoid valve spool.	<ul style="list-style-type: none"> • Measure brake circuit pressure. • If the pressure of releasing circuit is low, repair parking brake solenoid valve or replace it if necessary.
2. Propulsion Motor	Brake is worked because disk brake is stuck.	<ul style="list-style-type: none"> • Measure brake circuit pressure. • If the pressure of releasing circuit is high, repair propulsion motor or replace it if necessary.

GW754

SHOP MANUAL

SAKAI HEAVY INDUSTRIES, LTD.

Head office: Seiwa Bldg., 4-8, Shibadaimon 1-chome,
Minato-ku, Tokyo, Japan

Telephone: +81-3-3434-3401

Global Service Division: 2500 Takayanagi, Kuki-shi, Saitama, Japan

Telephone: +81-480-52-1111