



Be sure to operate, inspect, and maintain the products after you have read this manual carefully to understand the contents.

OPERATING & MAINTENANCE INSTRUCTIONS

PLATE COMPACTOR

PC800

SAKAI

Forward

This manual has been prepared as a guide to operate SAKAI PLATE COMPACTOR, PC800. It is hoped that the manual is useful for experienced operators to refresh the knowledge and the experiences as well as for inexperienced operators.

You are requested to use this product after you have fully understood the contents of this manual. Furthermore, keep this manual at a suitable place for your easy access.

Refer to a separate Engine Operation Manual for operation and maintenance of the engine.

If you lend or let other person to operate the machine, thoroughly explain how to operate it and guide him to read this manual in advance before operation. In addition, if you transfer the product to someone, provide him with the Engine Operation Manual as well as this instruction manual.

Please note that the purchased product may be somewhat different in the contents of the manual due to our constant efforts to improve its design.

Contents

When you order parts or get instructions for trouble correction	1
Safety precautions	2
1. Basic safety precautions	4
2. Sticking Position of Warning Notice (Label)	6
3. Inspection before operation	8
4. Starting-up	11
5. Operation	14
6. Shutting down	16
7. Inspection and Maintenance	17
8. Fuel and Lubricant	21
9. For a long-term storage	22
10. Overall View	23

When you order parts or get instructions for trouble correction

Be sure to inform us of the MODEL and its CHASSIS NUMBER when you are ordering parts or getting instructions for trouble correction. The PRODUCT MODEL and BODY NUMBER (Serial No.) are indicated on the body name plate.

The name plate is located on the rear side of the body for model PC800.

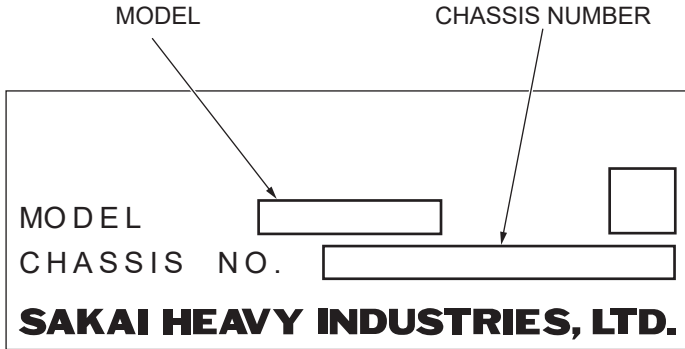

MODEL
PC800

CHASSIS NUMBER
○○○○○

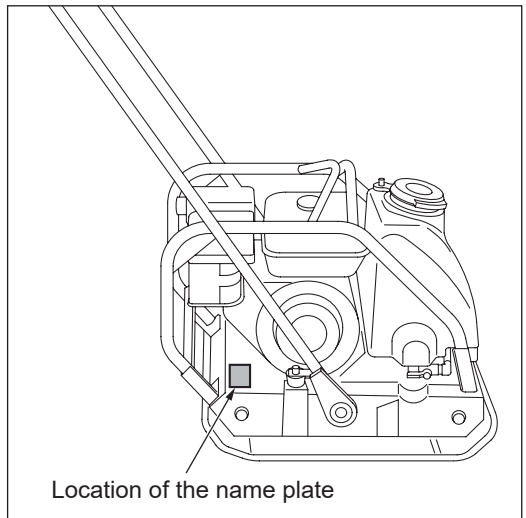

Safety precautions

In order to use this product safely, correct operation and periodical maintenance are absolutely essential. Do not operate and/or carry out maintenance of the product until you read the manual carefully to understand the safety precautions.

The operation and safety precautions illustrated in this manual are only limited for what it is to be used as a plate compactor. If the product is to be used for works other than what the manual covers, every safety consideration must be made on your responsibility.

In this manual, precautions, if they are failed to be observed, which may lead to an accident resulting in injury or death, are marked as "**⚠ DANGER**" or "**⚠ WARNING**".

Precautions, if they are failed to be observed, which may lead to injury or to serious damage to the machine, are marked as "**⚠ CAUTION**", and for precautions which may result in damage to the machine or shortening its service life are marked as "**IMPORTANT**".

In addition, labels indicating precautions in carrying out safety operation and maintenance service are stuck on the compactor as follows:

- | | |
|------------------|---|
| ⚠ DANGER | Indicates extremely high risk of an accident resulting in serious injury or death if it is failed to be observed.
(This is marked in red.) |
| ⚠ WARNING | Indicates a possibility to an accident resulting in serious injury or death if it is failed to be observed.
(This is marked in orange.) |
| ⚠ CAUTION | Indicates a possibility resulting in injury or damage to the machine if it is failed to be observed.
(This is marked in yellow.) |

In order to avoid an accident, you are requested to pay close attention to the safety other than the precautions indicated in this manual and/or on the labels during machine operation, as they could not cover all the precautions by foreseeing any possible danger.

 **WARNING**

Do not operate the machine until the operator has understood the contents by reading this manual carefully.

Wrong operation may invite an accident resulting in injury or death.

Safety operation of the machine is on operator's responsibility.

☆Cautions to be taken when making an alteration of the machine:

Making an alteration without our recommendation is a matter of question in terms of safety. Contact our local sales agent or office in advance for alteration.

We will not bear any responsibility for injury or breakdown of machine resulted from alteration without approval from our side.

☆Basic safety precautions to be taken in operating the machine are illustrated on the next page on.

1. Basic safety precautions

WARNING

Be sure to observe the safety precautions to secure safety.

Failure to observe the precautions will invite accidents or machine troubles.

1. Basic safety precautions

■ Read the instruction manual carefully.

- Understand functions of operation control equipment and familiarize yourself with where it is and how to control it. Also, have a proper understanding of how to operate and meaning of each symbol.



■ Observe the rules in work site.

- Observe the established rules such as prohibitions in the work site, cautions, and work procedures.

■ Wear clothes suitable for the work, and protective means.

- Wear clothes suitable for the work, safety shoes, and safety cap.
- Do not wear clothes which are likely to be caught in a projection of the machine, and/or an ornament. Also, do not wear a clothe stained with oil as it may catch fire easily.
- Never forget to wear protective goggles and a mask when required in the work.



■ Handle with care when hot members are at high temperature.

- Take care not to be burned as the engine as a whole is very hot during operation or immediately after it has been stopped.
- Do not allow your hand, body and clothe to be touched to the muffler as it is very hot while the engine is running or immediately after it has been stopped.
- Take care, while the engine is still hot, not to be burned from oil spray when draining or filling oil.



■ Pay attention to fire.

- Bringing a open flame close to fuel and oil may invite a fire. In particular, fuel can catch fire very easily and it is dangerous.
- Do not bring a fire such as of cigarette or of match close to the flammable materials.
- Supply fuel with the engine stopped after no fire has been confirmed around the compactor.
- Tighten the caps such as for fuel and for oil securely.



■ Pay attention to ventilation.

- Exhaust gas is harmful for your health. If the engine has to be run in a room or in a poorly ventilated area, ventilate the area by opening windows and/or entrances.



■ Check the machine body before operation.

- Check to see if each part of the machine functions properly at a safe place. If it is found anything wrong, be sure to take corrective measures to start operating the machine.
- Check the machine for unusual noise, unnatural vibration, heat and smell. If it is found something wrong, stop the machine at a safe place immediately and check and locate the cause to repair it.

■ Be careful not to be caught in the machine.

- Do not stand close to the machine while operating the machine because your hand, body, or clothe is likely to be caught in the rotating members which may result in an injury. Be sure to stop the engine before performing inspections and maintenance for rotating members such as V-belt, PTO pulley and its vicinity.
- Never try operating the machine with any of covers removed from the rotating members.



■ Cautions to be taken when loading and unloading the machine.

- Load and unload the machine in/from a transporting vehicle with two persons in order to avoid an accidental drop of the machine.
- Drain fuel from the fuel tank, the carburetor, and the fuel strainer before transporting it on a long distance or on a rough road.

2. Sticking Position of Warning Notice (Label)

2. Sticking Position of Warning Notice (Label)

For safety's sake, warning notice (label) is stuck to below mentioned position of our products. Keep the label clean and free of breakage. If it is broken or missed, replace it with a new one. When ordering labels, be sure to mention the relative part number printed at the bottom right corner of it.

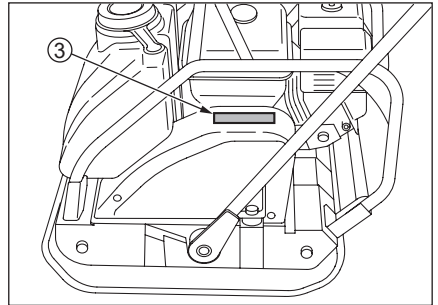
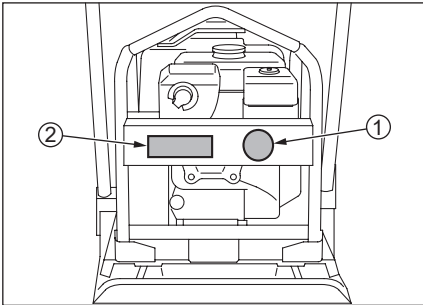

Detail of Warning Notice (Label)

① 3998-06140-0



② 3998-16491-2

	WARNING
<ul style="list-style-type: none">• Read the operator's manual thoroughly before operating the machine.• Incorrect operation can cause severe injury or death.• It is your responsibility to operate the machine safely.	
<small>3998-16491-2</small>	

③ 3998-16490-0

		DANGER
		<ul style="list-style-type: none">• Do not approach, or allow objects to touch, the rotating parts.• Body parts contacting rotating mechanism will be severed.
		<small>3998-16490-0</small>

Noise and vibration value of this machine are as follows:

Noise

(a) Operating conditions and measuring method

Place the machine on the soil and raise its rpm up to full throttle (3,800 rpm) and measure the noise using microphones set up at the position 1.5 m above ground and 7 m apart from the front, rear, left and right ends of the machine.

(b) Measured value

Equivalent continuous A weighted sound pressure level.....81 dB(A)

Vibration

(a) Operating conditions and measuring method

Place the machine on the soil and raise its rpm up to full throttle (3,800 rpm) and measure the vertical vibration acceleration at the hand grip portion of the handle.

(b) Measured value

Root mean square value.....32.0 m/sec²

3. Inspection before operation

3. Inspection before operation

3.1. Engine

Refer to a separate Engine Operation Manual for the engine.

3.2. Checking engine oil

- ① Remove the oil gauge and wipe off oil stuck on the gauge with a rag.
- ② Push the oil gauge against the oil fill port without screwing it in to check oil level.
- ③ Refill oil until it comes to the upper limit mark when the level is insufficient.



CAUTION

- Screw in the oil gauge securely after oil level has been checked and refilled.

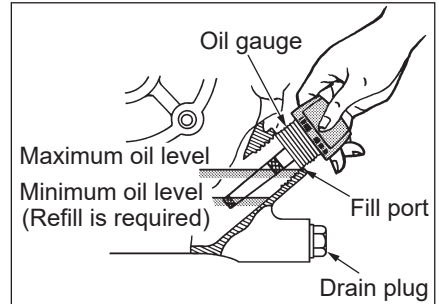

IMPORTANT

- Be sure to check and refill oil with the engine held level. Check the oil level again at approx. 3 minutes after it has been refilled.
- Do not supply oil more than the specified since over-supply of oil may result in blowing out of oil and poor output of the engine.
- Shortage of oil may cause seizure of the engine.
- If an oil other than the specified is used, service life of engine is likely to be shortened.

3.3. Checking oil in the vibrator

Remove the plug out of the fill-drain port in the vibrator with the machine body held level and check that the oil is filled up to the mouth of oil fill-drain port.

If it is found insufficient, supply oil to the extent that it comes full to mouth of the port.

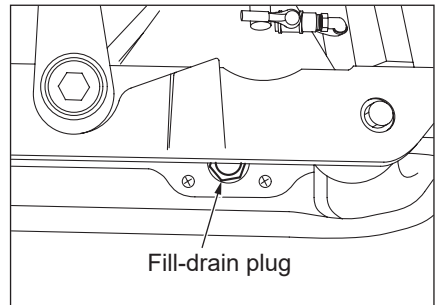

⚠ CAUTION

- Oil leaks out of the breather in the vibrator if the machine is left for a long period of time with the machine fallen down to the right or to the left. Do not block the breather except when it is necessary such as in carrying out a repair.

3.4. Checking fuel

⚠ WARNING

- Wipe off fuel thoroughly when it has been spilled out.
- Be sure to stop the engine when filling fuel.
- Tighten the cap on the fuel tank securely after fuel has been filled up.

⚠ CAUTION

- In order to prevent fuel from being blocked, be sure to fill up fuel through a filter.

Remove the cap on the fuel tank to check remaining oil visually. Refill fuel if it is found insufficient.

Fuel to be employed : Regular gasoline for automobile

⚠ WARNING

- Be sure to check if it is the right fuel before refilling fuel.

3.5. Checking bolts and nuts for their tightness

Bolts and nuts are likely to become loose due to vibration of the machine body.

If it is operated with the bolts and/or nuts loosened, lowering in function and damage to the machine may result. Inspect the machine body to re-tighten any loosened bolts and nuts.

4. Starting-up

(1) Open fuel cock full.

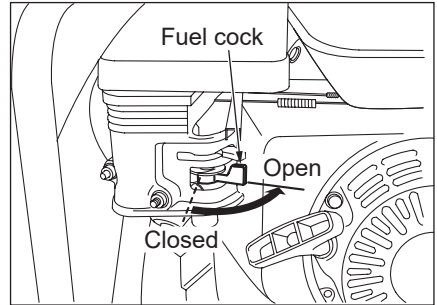

(2) Move speed control lever to half-open position.

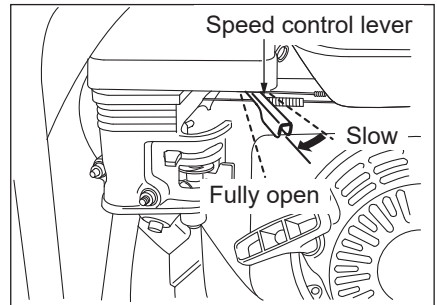

(3) Turn carburetor choke lever to fully closed position to facilitate ignition. (Turn lever to half-open position if engine is warm or when starting in warm weather.)

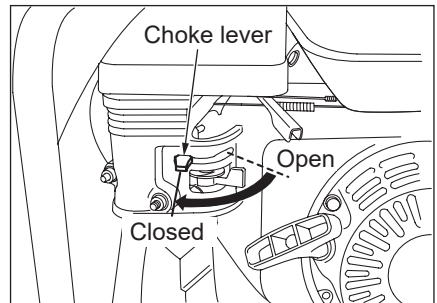

4. Starting-up

(4) Turn the engine switch ON.

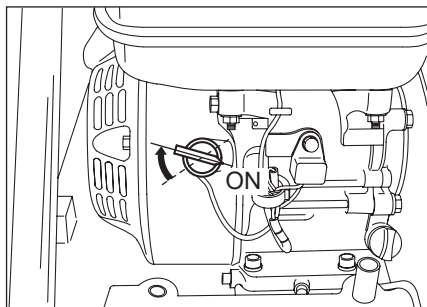

(5) Pull the starting knob forcibly.

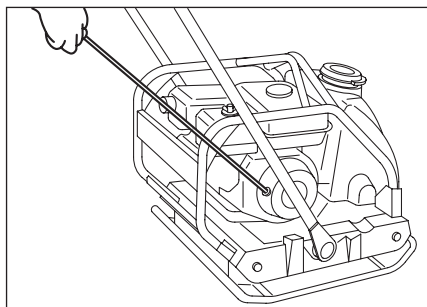

⚠ WARNING

- Start the engine after looking around to confirm the safety of its surroundings.
- Hold the handle securely with your left hand to fix the machine body and pull the starter knob forcibly with your right hand to start the engine.
- When pulling up the starter knob, pull it from immediately behind the handle, pull it from immediately behind the handle to prevent your hand from hitting the handle.

 **CAUTION**

- Do not pull out the rope up to its extreme. And when returning the rope, return it slowly as an abrupt release of the rope will cause damage to the cover with a shock.

- (6) Shift the choke lever to Fully open position after the engine has been started.

 **CAUTION**

- Warm-up the engine at an idling speed for 1 to 3 minutes after the engine has been started.
- If the engine fails to start, check the spark plug and the fuel system for blockage.

5. Operation

- (1) Shift the speed control lever to Full throttle after the warm-up operation has been completed.

CAUTION

- Do not operate the engine with an intermediate speed as the centrifugal clutch repeats ON and OFF in this speed which may result in seizure of the engine.

- (2) The compactor moves forward while vibrating.



CAUTION

- Do not apply vibration to a hard surface such as the concrete board.
- Do not get your hands off the handle while operating.
- When operating the compactor on a slope, operate it within a gradient of 1/4 (approx. 14 degrees).
- When operating the compactor on a rugged surface or on a surface with a sharp level difference, the compactor may easily tumble over or slip. Take care that you will not be injured in your wrist.
- Be sure to stop the engine before leaving the compactor unattended.

- (3) If the compactor is slow in its speed, check if soil or other surface materials are stuck to the tamping plate. Scrape them off the plate if they are.

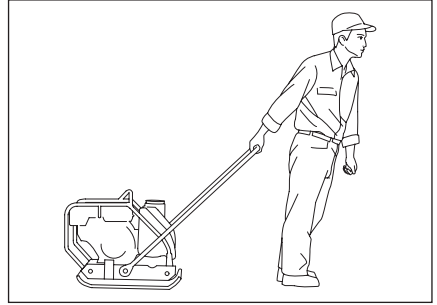

[Advice] When operating the compactor on a steep slope, incline the handle to front of body, then pull the handle to forward.

- (4) When you sprinkle water, turn the cock into the position of “open” .

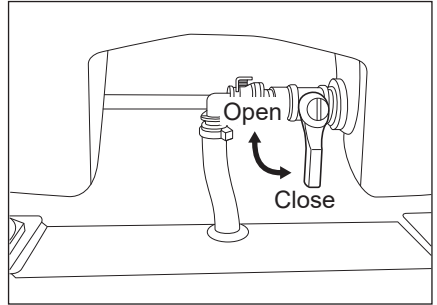

- (5) How to remove the water tank.

- Be sure to remove the “Hose” before removing the water tank.
- The hose can be removed by pressing the button on the cock.
- Lift the water tank upward.

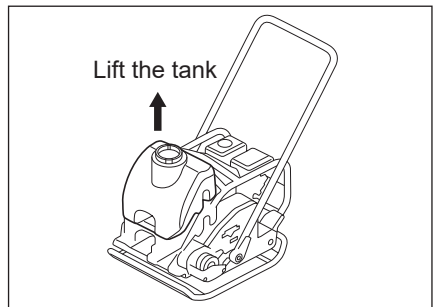
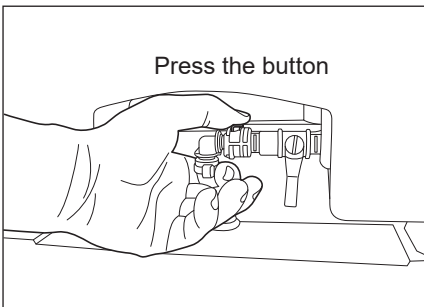

6. Shutting down

6. Shutting down

- (1) Return speed control lever to the lowest speed position and allow the engine to run for 1 to 2 minutes for cooling.



CAUTION

- Do not stop engine immediately after high-speed operation, otherwise oil deteriorates or motion members are stuck fast since the engine temperature rises suddenly.

- (2) Turn the engine switch OFF.

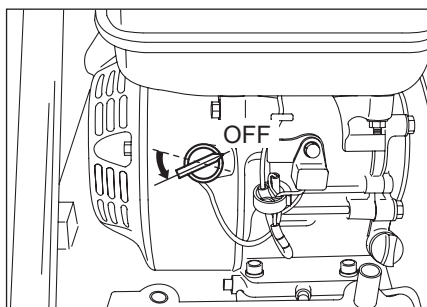

7. Inspection and Maintenance

7.1. Engine

Refer to a separate Engine Operation Manual for the engine.

7.2. Compactor body

Wipe off dust, dirt, and oil stuck on the body and inspect it for anything unusual.

Also, check bolts and nuts for tightness.

7.3. Spark plug

Remove the spark plug to clean off carbon deposit on the plug. Adjust electrode gap to between 0.7 mm and 0.8 mm.

Plug : BP6ES (NGK)

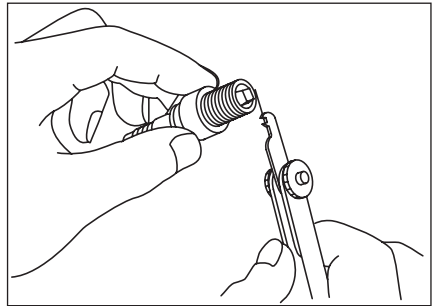

7. Inspection and Maintenance

7.4. Air cleaner

- ① Remove the wing nut from the air cleaner cover, and remove the cover.
- ② Remove the wing nut from the air filter, and remove the filter.
- ③ Remove the foam filter from the paper filter.
- ④ Inspect both air filter elements, and replace them if they are damaged. Always replace the paper air filter element at the scheduled interval.
- ⑤ Clean the air filter elements if they are to be reused.

Paper air filter element : Tap the filter element several times on a hard surface to remove dirt, or blow compressed air [not exceeding 30 psi (207 kPa, 2.1 kg/cm²)] through the filter element from the inside. Never try to brush off dirt; brushing will force dirt into the fibers.

Foam air filter element : Clean in warm soapy water, rinse, and allow to dry thoroughly. Or clean in nonflammable solvent and allow to dry. Dip the filter element in clean engine oil, then squeeze out all excess oil.

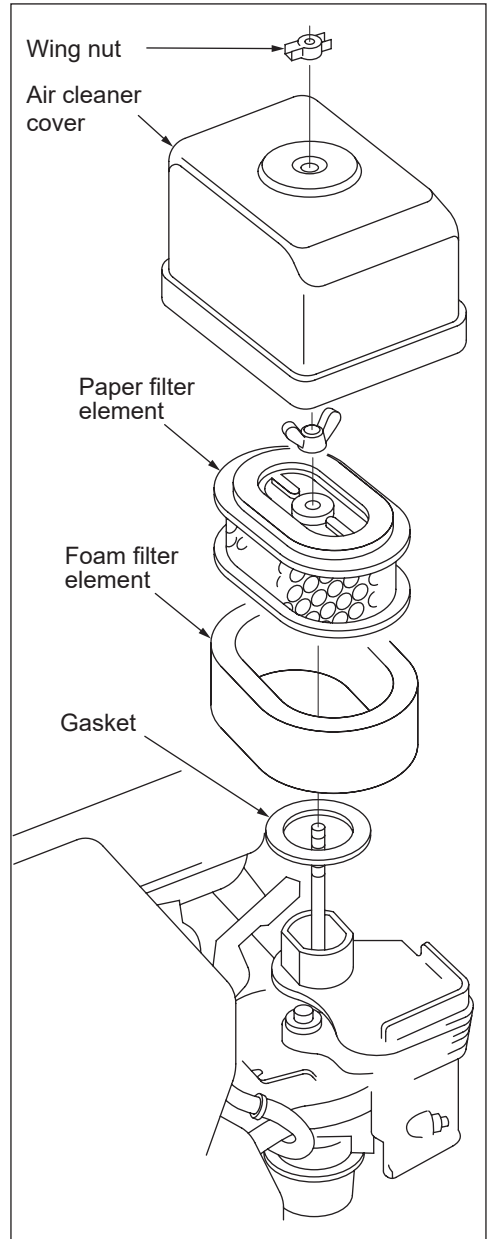

7.5. V-belt

Check the V-belt for its tension.

Adjust the tension so that it deflects 10 mm to 15 mm with a pressure applied with your thumb to a center point between both shafts.

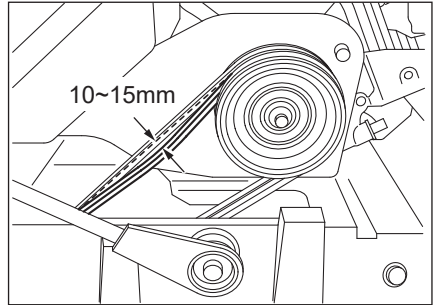

- ① Remove the front cover (standard type), water tank (water sprinkler system type).
- ② Loosen 4 bolts which secure the engine.
- ③ Remove the belt cover.
- ④ Remove the V-belt.
- ⑤ Remove the plates on the inside belt cover.
- ⑥ Loosen 4 bolts a little bit which secure the inside belt cover.
- ⑦ Insert the plates to the bottom of the engine.
- ⑧ Re-tighten 4 bolts of two places.
- ⑨ Set the V-belts.

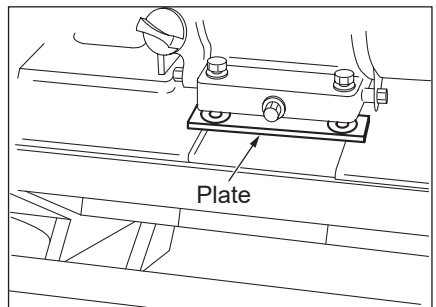
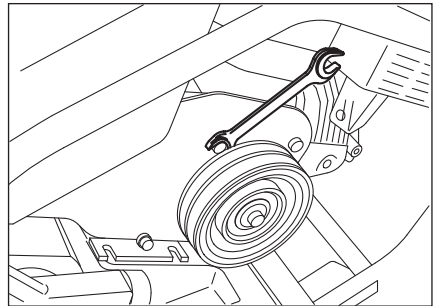

IMPORTANT

- Adjust the belt tension carefully as an inadequate adjustment remarkably shortens service life of the belt.

7. Inspection and Maintenance

7.6. Vibrator

Check the vibrator for oil leakage. Refill if the oil level is insufficient. Use the engine oil, 10W-30.

Remove the fill-Drain plug and fill the oil into the port until it comes to the mouth of the port.

Quantity specified : 350 cc

How to change oil:

Remove the belt cover, V-belts, and 4 bolts which secure the base. Remove the upper parts which installed a engine, cage from the body. Then remove the drain plug, Fill-Drain plug, or the oil level gauge and tilt the compactor body to drain the oil, then fill the new oil. Wipe off oil stuck on the outside of compactor after oil change.

Change oil at an interval of either one (1) month or 200 operating hours which comes first.

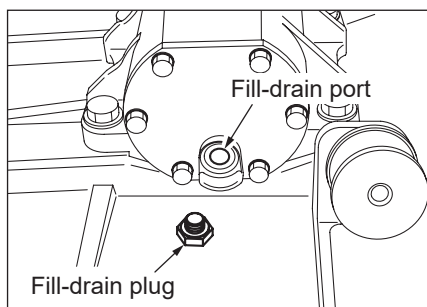

7.7. Checking bolts in each part for their tightness

Check the mounting bolts for tightness.

In particular, pay special attention around to the bolts securing engine, belt cover, rubber damper, and control handle.

8. Fuel and Lubricant

8.1. Fuel

Fuel to be employed : Regular gasoline for automobile

8.2. Engine oil/Vibrator oil

Season	Ambient temperature	Viscosity rating
Summer	25°C and above	SAE#30
Spring/Autumn	25°C ~ 10°C	SAE#30 or #20
Winter	10°C ~ -10°C	SAE#20
All-year-round	Regardless of temperature	SAE 10W-30

9. For a long-term storage

- (1) Drain fuel from the fuel tank and the carburetor completely and close the fuel cock.
- (2) Pull the starter knob slowly until resistance is felt and leave it in this condition.
- (3) Check the engine and the vibrator for oil leakage.
- (4) Wipe off oil stains, if any, on the rubber dampers.
- (5) Check bolts and nuts for tightness and re-tighten them as necessary.
- (6) Put the cover over the compactor and store it in a dust-free, dry area.

10. Overall View

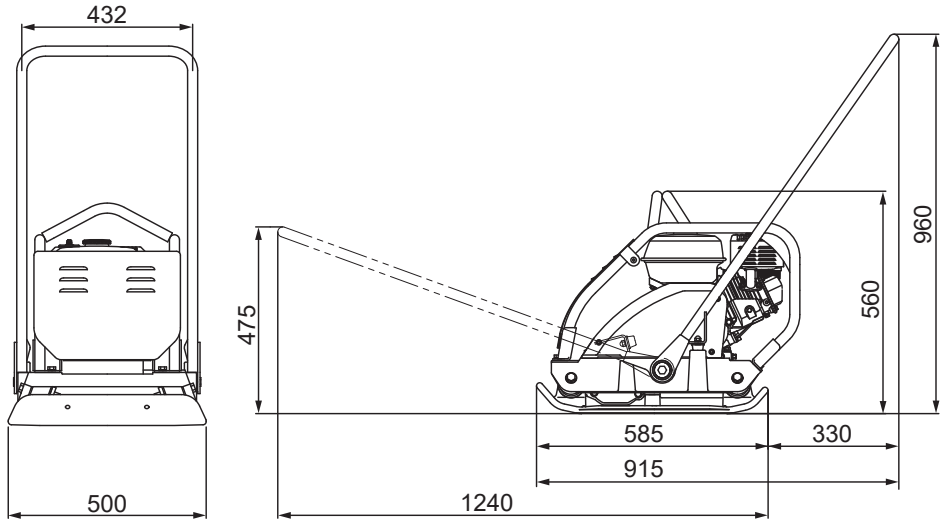

Model	PC800
Weight	
Operating weight	102 kg (225 lbs)
Dimension	
Overall length	915 mm (36")
Overall width	500 mm (19.7")
Overall height	960 mm (37.8")
Vibrating plate width x length	500 mm x 585 mm (19.7" x 23")
Performance	
Centrifugal force	16.2 kN (3,640 lbs)
Frequency	97 Hz (5,820 vpm)
Traveling speed	25 - 30 m/min
Engine	
Model	HONDA GX160
Maximum output	4.0 kW / 4,000 min ⁻¹ (5.4 HP / 4,000 min ⁻¹)
Fuel	Gasoline
Starting system	Recoil starter

NOTE : Operating weight : Fuel=50%

Maximum output : Maximum output in catalogue of engine manufacturer.

It does not always mean max. under operation of the machine.

SAKAI HEAVY INDUSTRIES, LTD.

Head office: 1-9-9, Shibadaimon, Minato-ku,
Tokyo, Japan

Telephone: 81-3-3431-9971

Facsimile: 81-3-3436-6212

SAKAI HEAVY INDUSTRIES, LTD.
