

⚠ Be sure to operate, inspect, and maintain the products after you have read this manual carefully to understand the contents.

**OPERATING &
MAINTENANCE
INSTRUCTIONS**

RAMMER

MODEL

RS Series

RS 55 RS 65 RS 75

for Diaphragm type

Forward

This manual has been prepared as a guide to operate SAKAI RAMMER, RS55, RS65, RS75.

It is hoped that the manual is useful for experienced operators to refresh the knowledge and the experiences as well as for inexperienced operators. You are requested to use this product after you have fully understood the contents of this manual. Furthermore, keep this manual at a suitable place for your easy access.

Refer to a separate Engine Operation Manual for operation and maintenance of the engine.

If you lend or let other person to operate the machine, thoroughly explain how to operate it and guide him to read this manual in advance before operation. In addition, if you transfer the product to someone, provide him with the Engine Operation Manual as well as this instruction manual.

Please note that the purchased product may be somewhat different in the the contents of the manual due to our constant efforts to improve its design.

Contents

Forward	
When you order parts or get instructions for trouble correction ...	1
Safety precautions	2
1 Basic safety precautions	4
2 Sticking position of warning notice (Label)	8
3 Inspection before operation	10
4 Starting-up	14
5 Operation	16
6 Shutting down	17
7 Inspection and maintenance	18
8 Fuel and lubricant.....	22
9 For a long-term storage	22
10 Specifications	23

When you order parts or get instructions for trouble correction

When you order parts or get instructions for trouble correction

Be sure to inform us of the MODEL and its CHASSIS NUMBER when you are ordering parts or getting instructions for trouble correction.

The PRODUCT MODEL and BODY NUMBER (Serial No.) are indicated on the body name plate.

The name plate is stuck on the left hand side of the body.

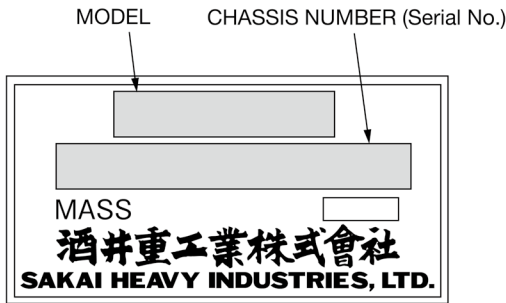

MODEL CHASSIS NUMBER

RS55 ⇨ 5RS7 - ○○○○○

RS65 ⇨ VRS2 - ○○○○○

RS75 ⇨ VRS3 - ○○○○○

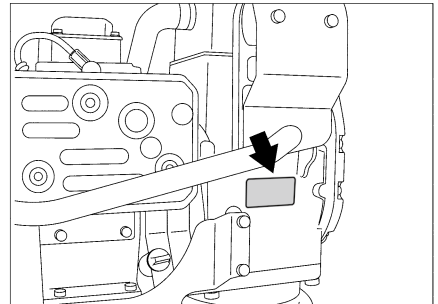

Safety precautions

In order to use this product safely, correct operation and periodical maintenance are absolutely essential. Do not operate and / or carry out maintenance of the product until you read the manual carefully to understand the safety precautions.

The operation and safety precautions illustrated in this manual are only limited for what it is to be used as a plate compactor. If the product is to be used for works other than what the manual covers, every safety consideration must be made on your responsibility.

In this manual, precautions, if they are failed to be observed, which may lead to an accident resulting in injury or death, are marked as **⚠ DANGER** or **⚠ WARNING**.

Precautions, if they are failed to be observed, which may lead to injury or to serious damage to the machine, are marked as **⚠ CAUTION**, and for precautions which may result in damage to the machine or shortening its service life are marked as **IMPORTANT**.

In addition, labels indicating precautions in carrying out safety operation and maintenance service are stuck on the compactor as follows:

- ⚠ DANGER** Indicates extremely high risk of an accident resulting in serious injury or death if it is failed to be observed (This is marked in red).

- ⚠ WARNING** Indicates a possibility to an accident resulting in serious injury or death if it is failed to be observed (This is marked in orange).

- ⚠ CAUTION** Indicates a possibility resulting in injury or damage to the machine if it is failed to be observed (This is marked in yellow).

In order to avoid an accident, you are requested to pay close attention to the safety other than the precautions indicated in this manual and / or on the labels during machine operation, as they could not cover all the precautions by foreseeing any possible danger.

 **WARNING**

Do not operate the machine until the operator has understood the contents by reading this manual carefully.

Wrong operation may invite an accident resulting in injury or death.

Safety operation of the machine is on operator's responsibility.

- ☆ Cautions to be taken when making an alteration of the machine:
Making an alteration without our recommendation is a matter of question in terms of safety.
Contact our local sales agent or office in advance for alteration.
We will not bear any responsibility for injury or breakdown of machine resulted from alteration without approval from our side.
- ☆ Basic safety precautions to be taken in operating the machine are illustrated on the next page on.

1 Basic safety precautions

WARNING

Be sure to observe the safety precautions to secure safety.

Failure to observe the precautions will invite accidents or machine troubles.

1 Basic safety precautions

■ Read the instruction manual carefully

- Understand functions of operation control equipment and familiarize yourself with where it is and how to control it.
- Also, have a proper understanding of how to operate and meaning of each symbol.



■ Observe the rules in work site

- Observe the established rules such as prohibitions in the work site, cautions, and work procedures.

■ Wear clothes suitable for the work, and protective means

- Wear clothes suitable for the work, safety shoes, and safety cap.
- Do not wear clothes which are likely to be caught in a projection of the machine, and / or an ornament. Also, do not wear a clothe stained with oil as it may catch fire easily.
- Never forget to wear protective goggles and a mask when required in the work.



■ Handle with care when hot members are at high temperature

- Take care not to be burned as the engine as a whole is very hot during operation or immediately after it has been stopped.
- Do not allow your hand, body and clothe to be touched to the muffler as it is very hot while the engine is running or immediately after it has been stopped.
- Take care, while the engine is still hot, not to be burned from oil spray when draining or filling oil.



■ Pay attention to fire

- Bringing a open flame close to fuel and oil may invite a fire.
In particular, fuel can catch fire very easily and it is dangerous.
- Do not bring a fire such as of cigarette or of match close to the flammable materials.
- Supply fuel with the engine stopped after no fire has been confirmed around the rammer.
- Tighten the caps such as for fuel and for oil securely.



■ Pay attention to ventilation

- Exhaust gas is harmful for your health. If the engine has to be run in a room or in a poorly ventilated area, ventilate the area by opening windows and / or entrances.



1 Basic safety precautions

■ Check the machine body before operation

- Check to see if each part of the machine functions properly at a safe place. If it is found anything wrong, be sure to take corrective measures to start operating the machine.
- Check the machine for unusual noise, unnatural vibration, heat and smell. If it is found something wrong, stop the machine at a safe place immediately and check and locate the cause to repair it.

■ Be careful not to be caught in the machine

- Do not stand close to the machine while operating the machine because your hand, body, or clothe is likely to be caught in the rotating members which may result in an injury.

Be careful not to be caught in the machine.

Be sure to stop the engine before performing inspections and maintenance for rotating members and their vicinities.

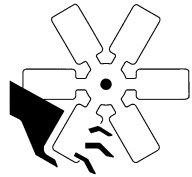

■ **Cautions to be taken when loading and unloading the machine**

- Load and unload the machine in / from a transporting vehicle with two persons in order to avoid an accidental drop of the machine.
- Drain fuel from the fuel tank, the carburetor, and the fuel strainer before transporting it on a long distance or on a rough road.

⚠ DANGER

When lifting up the machine by holding the handle, hold the handle at its front and rear part to prevent your finger and / or hand from being caught between the handle and the machine body.

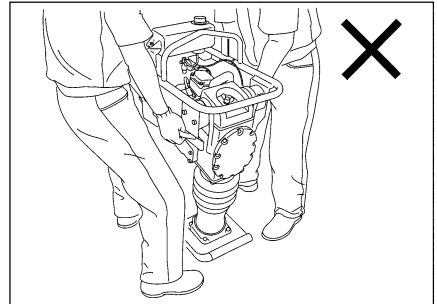
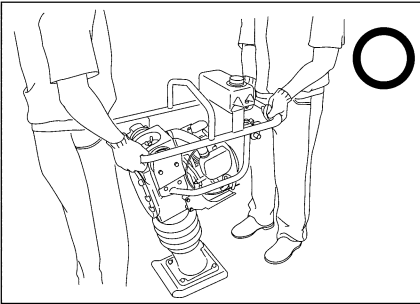

■ **Cautions to be taken when loading and unloading using a crane**

- Surely bind the guard with a wire rope as shown in the figure on the right.

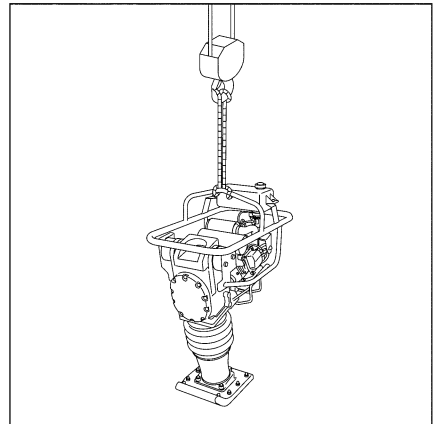

2 Sticking position of warning notice (Label)

2 Sticking position of warning notice (Label)

For safety's sake, warning notice (label) is stuck to below mentioned position of our products.

Keep the label clean and free of breakage. If it is broken or missed, replace it with a new one.

When ordering labels, be sure to mention the relative part number printed at the next page.

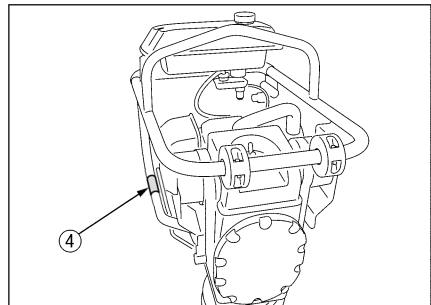
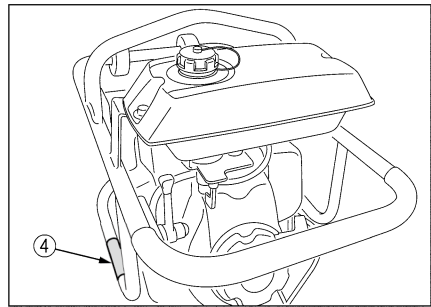
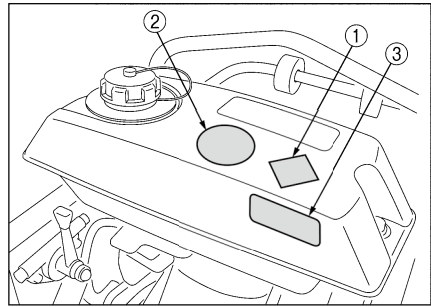

2 Sticking position of warning notice (Label)

Detail of warning notice (Label)

① 3998-36001-0



② 3998-06140-0



③ 1472-19018-0

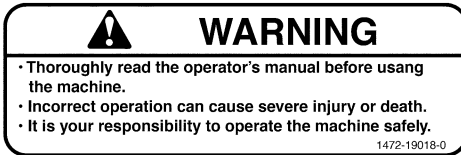

④ 1466-19019-0

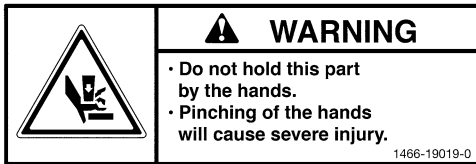

3 Inspection before operation

3 Inspection before operation

3.1 Engine

Refer to a separate Engine Operation Manual for the engine.

3.2 Checking oil in the engine

- 1) Remove the oil gauge and wipe off oil stuck on the gauge with a rag.
- 2) Push the oil gauge against the oil fill port without screwing it in to check oil level.
- 3) Refill oil until it comes to the upper limit mark when the level is insufficient.

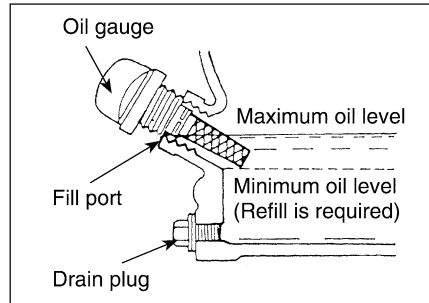

Quantity specified : 0.28 liters

⚠ CAUTION

Screw in the oil gauge securely after oil level has been checked and refilled.

IMPORTANT

- **Be sure to check and refill oil with the tamping shoe held level. Check the oil level again at approx. 3 minutes after it has been refilled.**
- **Do not supply oil more than the specified since over-supply of oil may result in blowing out of oil and poor output of the engine.**
- **Shortage of oil may cause seizure of the engine.**
- **If an oil other than the specified is used, service life of engine is likely to be shortened.**

3.3 Checking oil in the cylinder

Remove the fill plug located in the lower cylinder case with the tamping shoe held level and check that the oil is filled up to the mouth of the port. If it is found insufficient, supply oil to the extent that it comes full to mouth of the port.

Quantity specified

RS55 : 0.5 liters

RS65 : 0.8 liters

RS75 : 0.9 liters

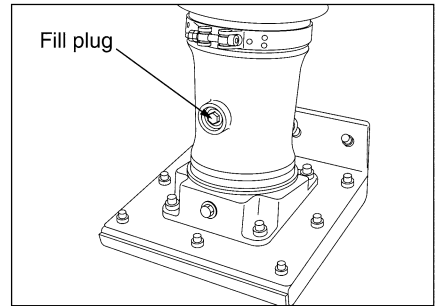

IMPORTANT

- **Be sure to check and refill oil with the tamping shoe held level.**
- **Run the engine for a while after oil has refilled then check the oil level again at approx. 3 to 5 minutes after engine has been stopped. If oil has been filled more than the specified, malfunction results. Be sure to wipe it off when over-filled.**
- **If an oil other than the specified is used, service life of engine is likely to be shortened.**

3 Inspection before operation

3.4 Checking fuel

Remove the cap on the fuel tank to check remaining oil visually. Refill fuel if it is found insufficient.

Fuel to be employed :

Regular gasoline for automobile.

Fuel tank capacity : 2.8 liters

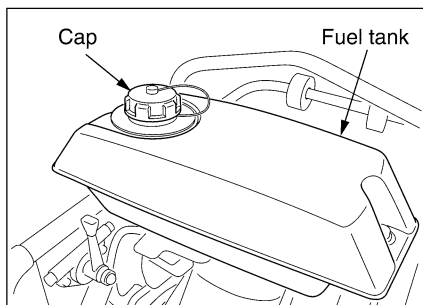

⚠ WARNING

- Be sure to stop the engine when filling fuel.
- Be sure to check if it is the right fuel before refilling fuel.
- Wipe off fuel thoroughly when it has been spilled out.
- Tighten the cap on the fuel tank securely after fuel has been filled up.

⚠ CAUTION

In order to prevent fuel from being blocked. Be sure to fill up fuel through a filter.

IMPORTANT

Since shortage of fuel can cause irregular tamping motion due to uneven fuel supply to the engine by vertical (vibrating) motion of the machine, refill fuel a little earlier.

3.5 Checking bolts and nuts for their tightness

Re-tighten bolts and nuts in each section after each operation and once a week.

Bolts and nuts are likely to become loose due to vibration of the machine body.

If it is operated with the bolts and / or nuts loosened, malfunction and damage to the machine may result.

In particular, be sure to check bolts and nuts securing tamping shoe before starting operation.

⚠ CAUTION

Since crankcase and its related members are made of aluminum, be careful not to over-tighten them.

3.6 Handle height adjustment

Handle height can be adjusted in two (2) steps to meet the operator's height.

It can easily be adjusted by relocating handle counting bolts.

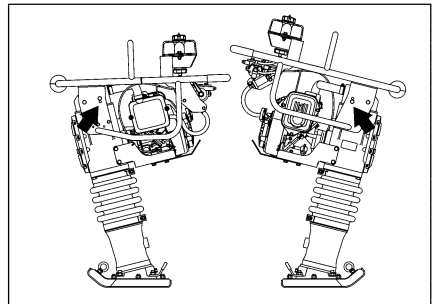

4 Starting-up

4 Starting-up

- 1) Turn the throttle lever to “Start” position.

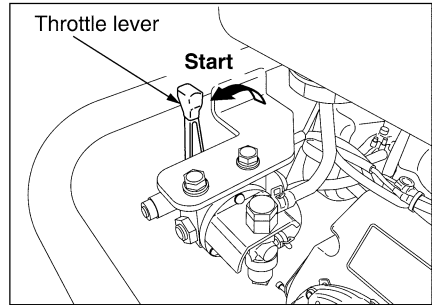

- 2) Close the choke lever in the carburetor.

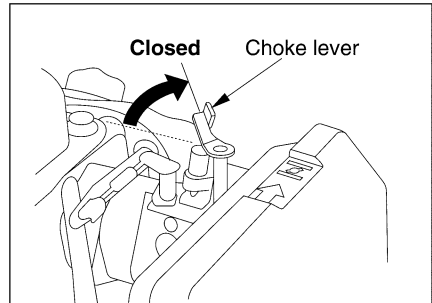

IMPORTANT

Position the lever to a halfway between “Closed” and “Fully open” when temperature is warm or the engine is still hot. Likewise, position the lever to Closed when temperature is low.

3) Pull the starting knob forcibly.

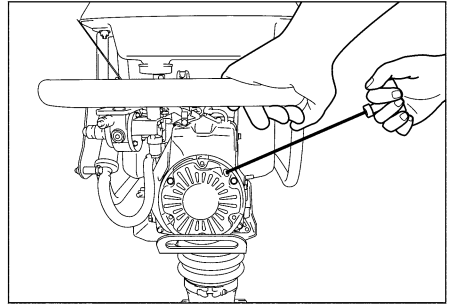

⚠ WARNING

- Start the engine after looking around to confirm the safety of its surroundings.
- Hold the handle securely with your left hand to fix the machine body and pull the starter knob forcibly with your right hand to start the engine.
- Pull up the starter knob so that your hand will not hit the handle.

⚠ CAUTION

- Do not pull out the rope up to its extreme. And when returning the rope, return it slowly as an abrupt release of the rope will cause damage to the cover with a shock.

4) Shift the choke lever to “Fully open” position after the engine has been started.

⚠ CAUTION

- Warm-up the engine at an idling speed for approx. 1 to 3 minutes after the engine has been started.
- If the engine fails to start, check the spark plug and the fuel system for blockage.

5 Operation

5 Operation

- 1) Shift the throttle lever to “High” position after the warm-up operation has been completed. Rammer starts tamping motion and moving forward.

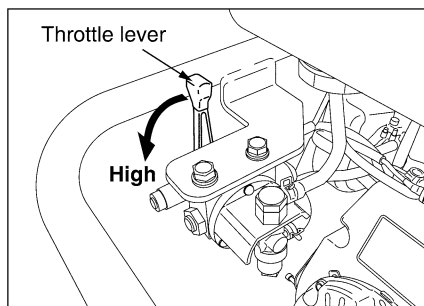

⚠ DANGER

During operation, do not lift up the machine by holding the handle.

⚠ CAUTION

- Do not operate the engine with an intermediate speed as the centrifugal clutch repeats ON and OFF in this speed which may result in seizure of the engine.
- Shift the throttle lever swiftly to “High” position. If throttle lever is shifted slowly, it will cause irregular machine motion and say damage clutch, springs, and tamping shoe.
- Do not operate the rammer for driving a pile or on a solid ground exceeding capacity of the machine such as surface paved with asphalt, concrete, cobblestone, and solid rock. Otherwise, this may cause damage to the machine as too much stress is applied to the machine body.
- Do not get your hands off the handle while operating.
- When operating the rammer on a ground surface with a large roughness and a large level difference, or on a steep slope, take care that you will not be injured in your wrist due to overturn or slip of the machine body. In addition, this may cause earlier damage to the machine as an excessive stress is also applied to the machine body.
- Be sure to stop the engine before leaving the rammer unattended.

6 Shutting down

- 1) Return the throttle lever to “Start” Position and allow the engine to run for 1 to 2 minutes for cooling.

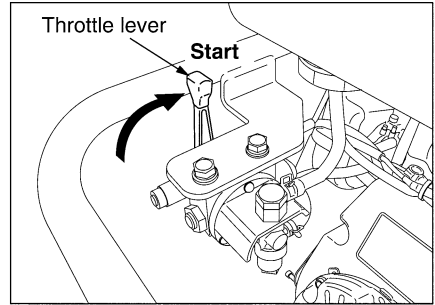

⚠ CAUTION

- Return the throttle lever swiftly as in the start-up operation.
- Do not stop engine immediately after high-speed operation. Otherwise oil deteriorates or motion members are stuck fast since the engine temperature rises suddenly.

- 2) Return the throttle lever to “Stop” position. Then, the engine stop and the fuel cock shuts at the same time.

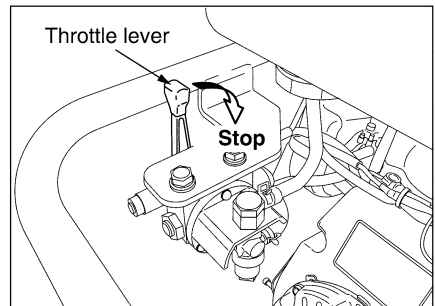

7 Inspection and maintenance

7.1 Engine

Refer to a separate Engine Operation Manual for the engine.

7.2 Rammer body

Wipe off dust, dirt, and oil stuck on the body and inspect it for anything unusual.

Also, check bolts and nuts for tightness.

7.3 Spark plug

Remove the spark plug to clean off carbon deposit on the plug. Adjust electrode gap to between 0.6mm and 0.7mm.

Recommended spark plug :
CRHSB (NGK)

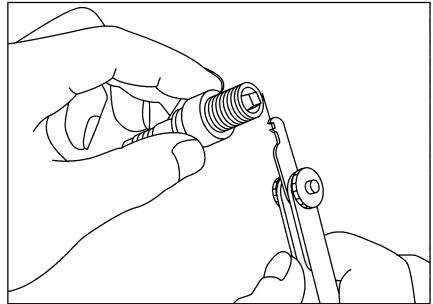

7.4 Cleaning of air cleaner (once every 3 months or 50 hours of operation)

For the urethane foam ① :

Dry it well after it has been washed with wash oil or neutral detergent diluted with water.

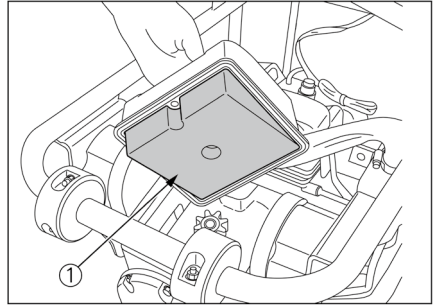

For the element ② :

Blow compressed air from the inside or pat it lightly to clean it.

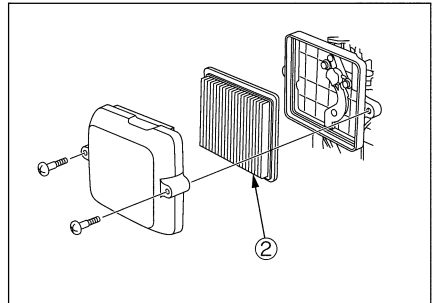

7 Inspection and maintenance

7.5 Replacement of cylinder oil

Replace the oil after 3 months or 50 hours of operation for the first time, and every 1 year or 200 hours of operation thereafter. Wipe off the oil stuck on the rammer after oil has been replaced.

How to replace oil:

Remove the drain plug and tilt the rammer to discharge oil, then fill in the new oil.

Position the tamping shoe held level to supply oil until it comes full to mouth of oil fill port.

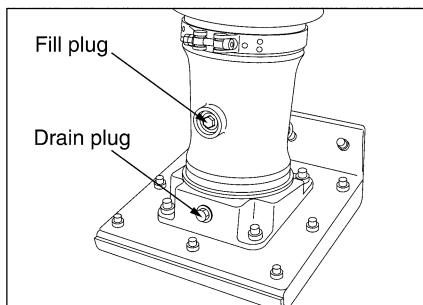

Quantity specified

RS55 : 0.5 liters

RS65 : 0.8 liters

RS75 : 0.9 liters

7.6 Checking bolts in each section for their tightness

Check the mounting bolts for tightness. In particular, pay special attention around to the bolts securing engine, crankcase, tamping shoe, and handle.

7.7 Replacement of fuel filter

Replace the fuel filter if the engine makes an abnormal rotation despite the fact that the fuel is well fed into the fuel filter.

Part number : 1469-47072-0

When in replacement of the fuel filter, be sure to replace it in the right direction.

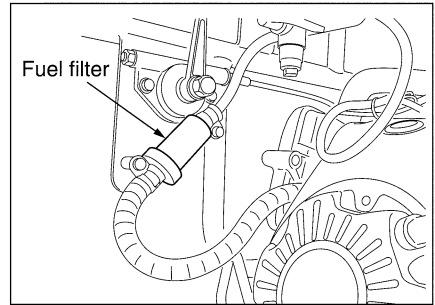

⚠ CAUTION

Be careful with fire during replacement of the fuel filter as the gasoline in the filter and in the fueling pipes may be spilled out.

8 Fuel and lubricant

8.1 Fuel

Fuel to be employed : Regular gasoline for automobile

Fuel tank capacity : 2.8 liters

8.2 Engine oil / Cylinder oil

Use API / SE or higher grade oil.

Use oil with a viscosity rating that is appropriate for the outside air temperature.

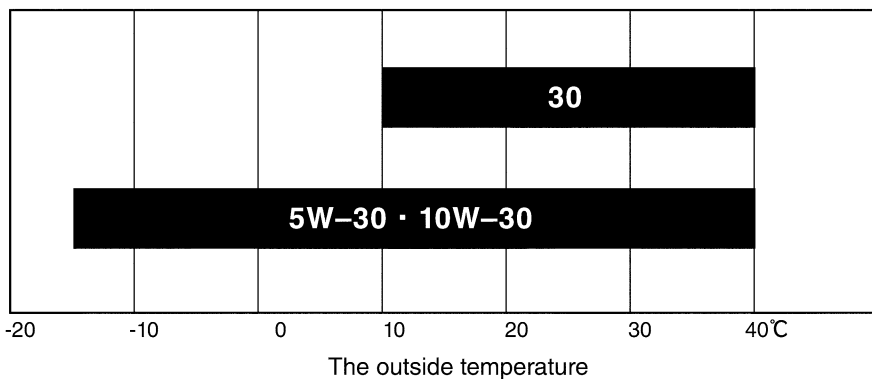

9 For a long-term storage

- 1) Drain fuel from the fuel tank and the carburetor completely.
- 2) Pull the recoil starter knob slowly until resistance is felt and leave it in this condition.
- 3) Check the engine and the cylinder for oil leakage.
- 4) Wipe off oil stains, if any, on the rubber dampers.
- 5) Check bolts and nuts for tightness and re-tighten them as necessary.
- 6) Put the cover over the rammer and store it in a dust-free, dry area.

10 Specifications

RS55

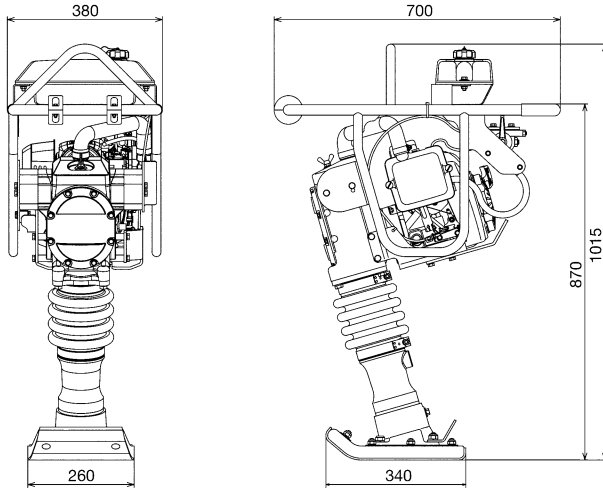

Model	RS55
Physical	
Machine Weight *1	60 kg
Total Length	700 mm
Total Width	380 mm
Total Height	1015 mm
Size of Tamping Plate	340 mm (L) × 260 mm (W)
Performance	
Traveling stroke	40 – 60 mm
Frequency	10.8 – 11.5 Hz (650 – 690 vpm)
Traveling Speed	8 – 12 m / min
Engine	
Manufacturer's Model	HONDA model GX100
Maximum Output *2	2.3 kW / 4000 min ⁻¹ (3.1 PS / 4000 rpm)
Fuel	Gasoline
Starting System	Recoil starter

*1. Indicating condition of the weight:

The weight to be indicated includes half the weight of fuel of the tank capacity and does not include the weight of water for sprinkling use.

*2. Engine output indication : This indicates maximum output at the operating speed.

10 Specifications

RS65

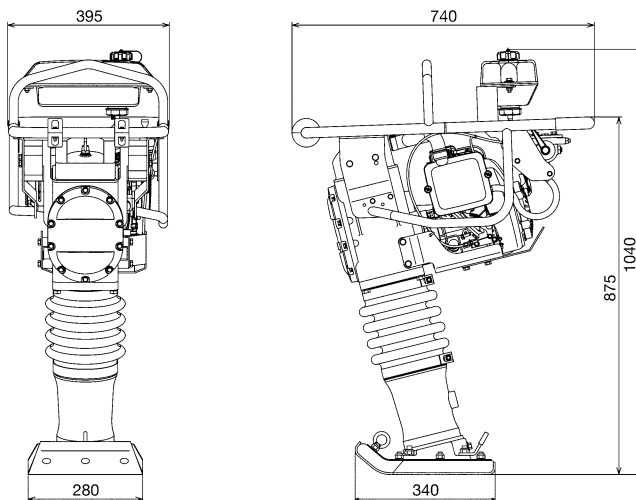

Model	RS65
Physical	
Machine Weight *1	69 kg
Total Length	740 mm
Total Width	395 mm
Total Height	1,040 mm
Size of Tamping Plate	340 mm (L) × 280 mm (W)
Performance	
Traveling stroke	50 – 70 mm
Frequency	10.7 – 11.3 Hz (640 – 680 vpm)
Traveling Speed	12 – 16 m / min
Engine	
Manufacturer's Model	HONDA model GX100
Maximum Output *2	2.1 kW / 3600 min ⁻¹ (2.9 PS / 3600 rpm)
Fuel	Gasoline
Starting System	Recoil starter

*1. Indicating condition of the weight:

The weight to be indicated includes half the weight of fuel of the tank capacity and does not include the weight of water for sprinkling use.

*2. Engine output indication : This indicates maximum output at the operating speed.

RS75

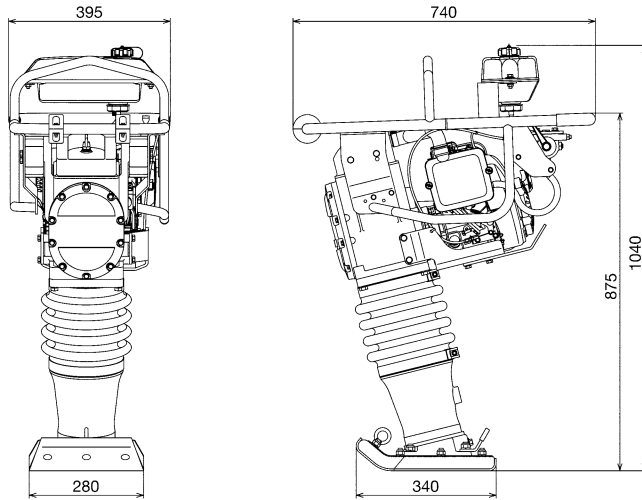

Model	RS75
Physical	
Machine Weight *1	75 kg
Total Length	740 mm
Total Width	395 mm
Total Height	1,040 mm
Size of Tamping Plate	340 mm (L) × 280 mm (W)
Performance	
Traveling stroke	50 – 70 mm
Frequency	10.7 – 11.3 Hz (640 – 680 vpm)
Traveling Speed	12 – 16 m / min
Engine	
Manufacturer's Model	HONDA model GXR120
Maximum Output *2	2.7 kW / 3600 min ⁻¹ (3.7 PS / 3600 rpm)
Fuel	Gasoline
Starting System	Recoil starter

*1. Indicating condition of the weight:

The weight to be indicated includes half the weight of fuel of the tank capacity and does not include the weight of water for sprinkling use.

*2. Engine output indication : This indicates maximum output at the operating speed.

SAKAI HEAVY INDUSTRIES, LTD.

Head Office: 1-4-8, Shibadaimon, Minato-ku,
Tokyo, Japan

Telephone: Tokyo 81-3-3431-9971

Facsimile: 81-3-3436-6212

SAKAI HEAVY INDUSTRIES, LTD.
